



# Dolby Digital Speaker System

## OWNER'S MANUAL

**MODEL : LH-A4000**

(Speakers: LHS-A4000T, LHS-A4000C, LHS-A4000WA/WD/WX)

Before connecting, operating or adjusting this product,  
please read this instruction booklet carefully and completely.



## Safety Precautions



**CAUTION**  
RISK OF ELECTRIC SHOCK  
DO NOT OPEN



**WARNING:** TO REDUCE THE RISK OF ELECTRIC SHOCK DO NOT REMOVE COVER (OR BACK) NO USER-SERVICEABLE PARTS INSIDE REFER SERVICING TO QUALIFIED SERVICE PERSONNEL.



This lightning flash with arrowhead symbol within an equilateral triangle is intended to alert the user to the presence of uninsulated dangerous voltage within the product's enclosure that may be of sufficient magnitude to constitute a risk of electric shock to persons.



The exclamation point within an equilateral triangle is intended to alert the user to the presence of important operating and maintenance (servicing) instructions in the literature accompanying the appliance.

**WARNING:** TO REDUCE THE RISK OF FIRE OR ELECTRIC SHOCK, DO NOT EXPOSE THIS PRODUCT TO RAIN OR MOISTURE.

**WARNING:** Do not install this equipment in a confined space such as a book case or similar unit.

CLASS 1 LASER PRODUCT  
KLASSE 1 LASER PRODUKT  
LUOKAN 1 LASER LAITE  
KLASS 1 LASER APPARAT  
CLASSE 1 PRODUIT LASER

### CAUTION:

To ensure proper use of this product, please read this owner's manual carefully and retain for future reference, should the unit require maintenance, contact an authorized service location—see service procedure.

Use of controls, adjustments or the performance of procedures other than those specified herein may result in hazardous radiation exposure.

The apparatus shall not be exposed to water, dripping or splashing and that no objects filled with liquids, such as vases, shall be placed on the apparatus.

**SERIAL NUMBER:** The serial number is found on the back of this unit. This number is unique to this unit and not available to others. You should record requested information here and retain this guide as a permanent record of your purchase.

Model No. \_\_\_\_\_

Serial No. \_\_\_\_\_

The cord grip for the plug fitted to this product is built into the existing power cord as supplied. If, for any reason you need to shorten the cord,

A new plug must be used to ensure your continued safety by securing the plug to the power cord in accordance with Plug & Socket Regulations 1994.

## Table of Contents

Safety Precautions . . . . .	2
Table of Contents . . . . .	3
Before Use . . . . .	3
Precautions . . . . .	3
About the Symbols for instructions . . . . .	3
Diagrams of equipment . . . . .	4
Front View . . . . .	4
Rear View . . . . .	4
Display Window . . . . .	4
Remote Control . . . . .	4
Speaker Positioning . . . . .	5
Connections . . . . .	6-7
Speaker System Connection . . . . .	6
Antenna (Aerial) Connections . . . . .	6
Connecting to Optional Equipment . . . . .	7
Display Information about External Digital Input Signal . . . . .	7
Presetting the radio stations . . . . .	8
Listening to the radio . . . . .	8
RDS Function - OPTIONAL . . . . .	9
About RDS . . . . .	9
Programme Search (PTY) . . . . .	9
Speaker Setup . . . . .	10
Delay Time Setting . . . . .	10
Mini Glossary for Sound Mode . . . . .	11
Sound Adjustment . . . . .	12
Sound Mode . . . . .	12
Sound Level . . . . .	12
Mute . . . . .	12
Test Tone . . . . .	12
Sleep Timer Setting . . . . .	12
Selecting input source . . . . .	12
Before Requesting Service . . . . .	13
Specifications . . . . .	14



### Remote Control Operation Range

Point the remote control at the remote sensor and press the buttons.

- **Distance:** About 23 ft (7 m) from the front of the remote sensor
- **Angle:** About 30° in each direction of the front of the remote sensor

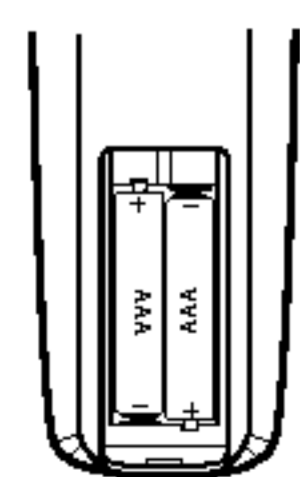
#### Remote control battery installation



Detach the battery cover on the rear of the remote control, and insert two R03 (size AAA) batteries with  and  aligned correctly.



#### Caution

Do not mix old and new batteries. Never mix different types of batteries (standard, alkaline, etc.).

## Before Use

### Precautions

#### Handling the unit

##### When shipping the unit

The original shipping carton and packing materials come in handy. For maximum protection, re-pack the unit as it was originally packed at the factory.

##### To keep the surface clean

Do not use volatile liquids, such as insecticide spray, near the unit. Do not leave rubber or plastic products in contact with the unit for a long period of time. They will leave marks on the surface.

##### Installing

- Do not install the unit in a confined space, such as a bookcase or built-in cabinet.
- Allow adequate air circulation to prevent internal heat buildup.
- Do not place the unit on surfaces (rugs, blankets, etc.) or near materials (curtains, draperies) that may block the ventilation slots.
- Do not install the unit near heat sources such as radiators or air ducts, or in a place subject to direct sunlight, excessive dust, mechanical vibration or shock.
- Do not place heavy objects on the unit.

#### Cleaning the unit

##### To clean the cabinet

Use a soft, dry cloth. If the surfaces are extremely dirty, use a soft cloth lightly moistened with a mild detergent solution. Do not use strong solvents, such as alcohol, benzene, or thinner, as these might damage the surface of the unit.

### About the symbols for instructions



Indicates hazards likely to cause harm to the unit itself or other material damage.



Indicates special operating features of this unit.



Indicates tips and hints for making the task easier.

Manufactured under license from Dolby Laboratories. "Dolby", "Pro Logic", and the double-D symbol are trademarks of Dolby Laboratories. Confidential Unpublished works. Copyright 1992-1997 Dolby Laboratories. All rights reserved.

Manufactured under license from Digital Theater Systems, Inc. US Pat. No. 5,451,942 5,956,674, 5,974,380, 5,978,762 and other world-wide patents issued and pending. "DTS" and "DTS Digital Surround" are registered trademarks of Digital Theater Systems, Inc. Copyright 1996, 2000 Digital Theater Systems, Inc. All rights reserved.

## Diagrams of equipment

### Front View

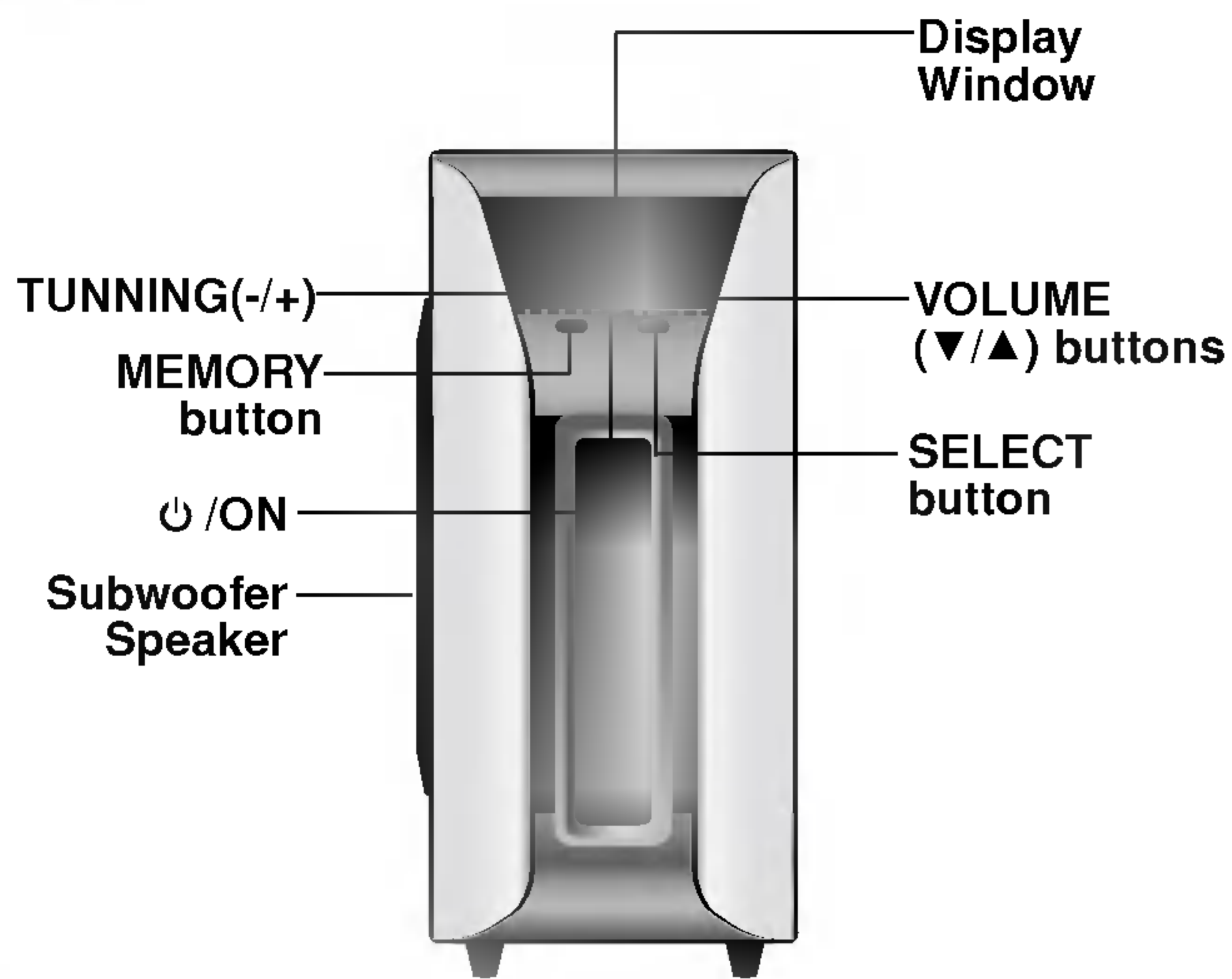

### Rear View

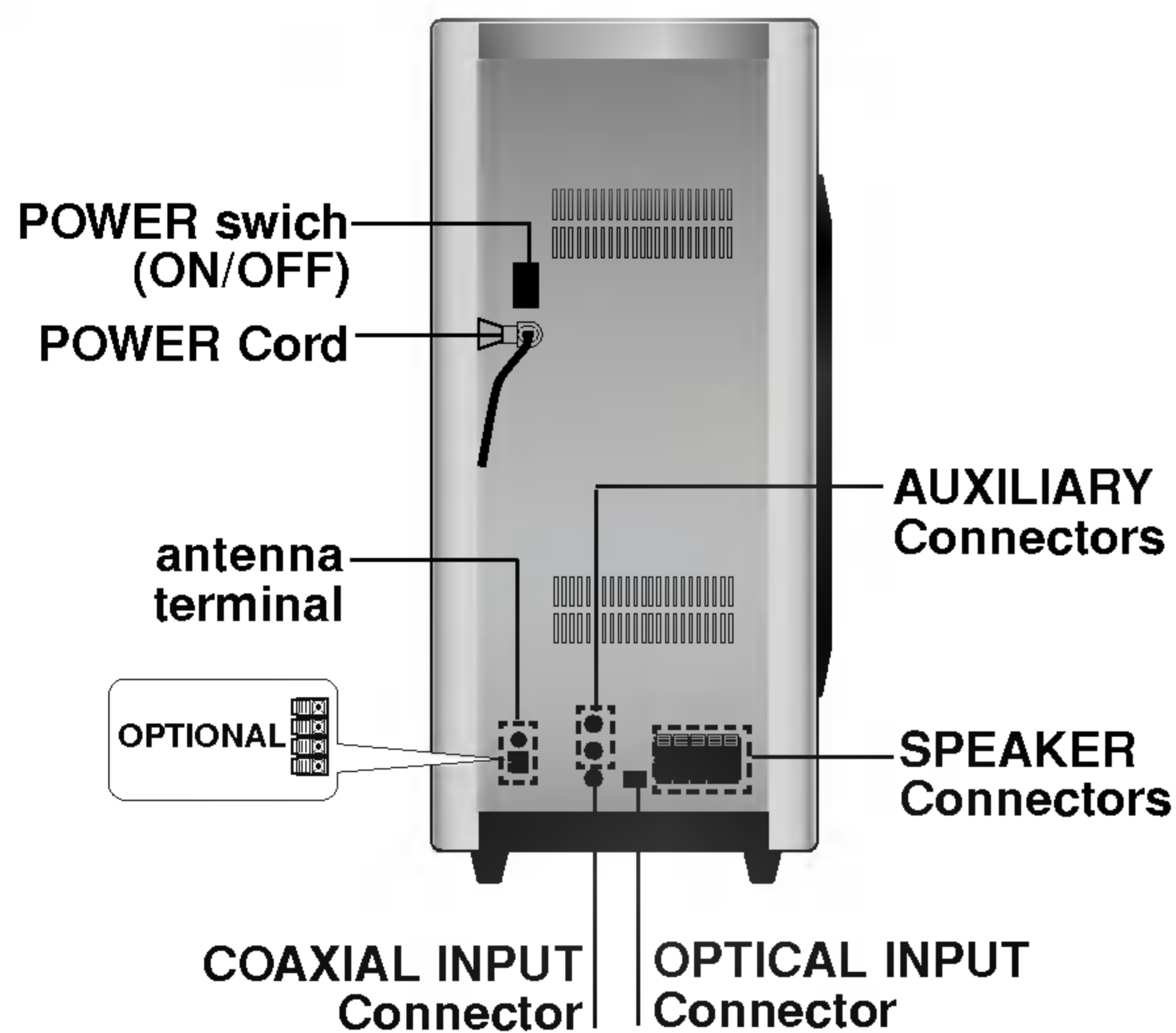

### Display Window

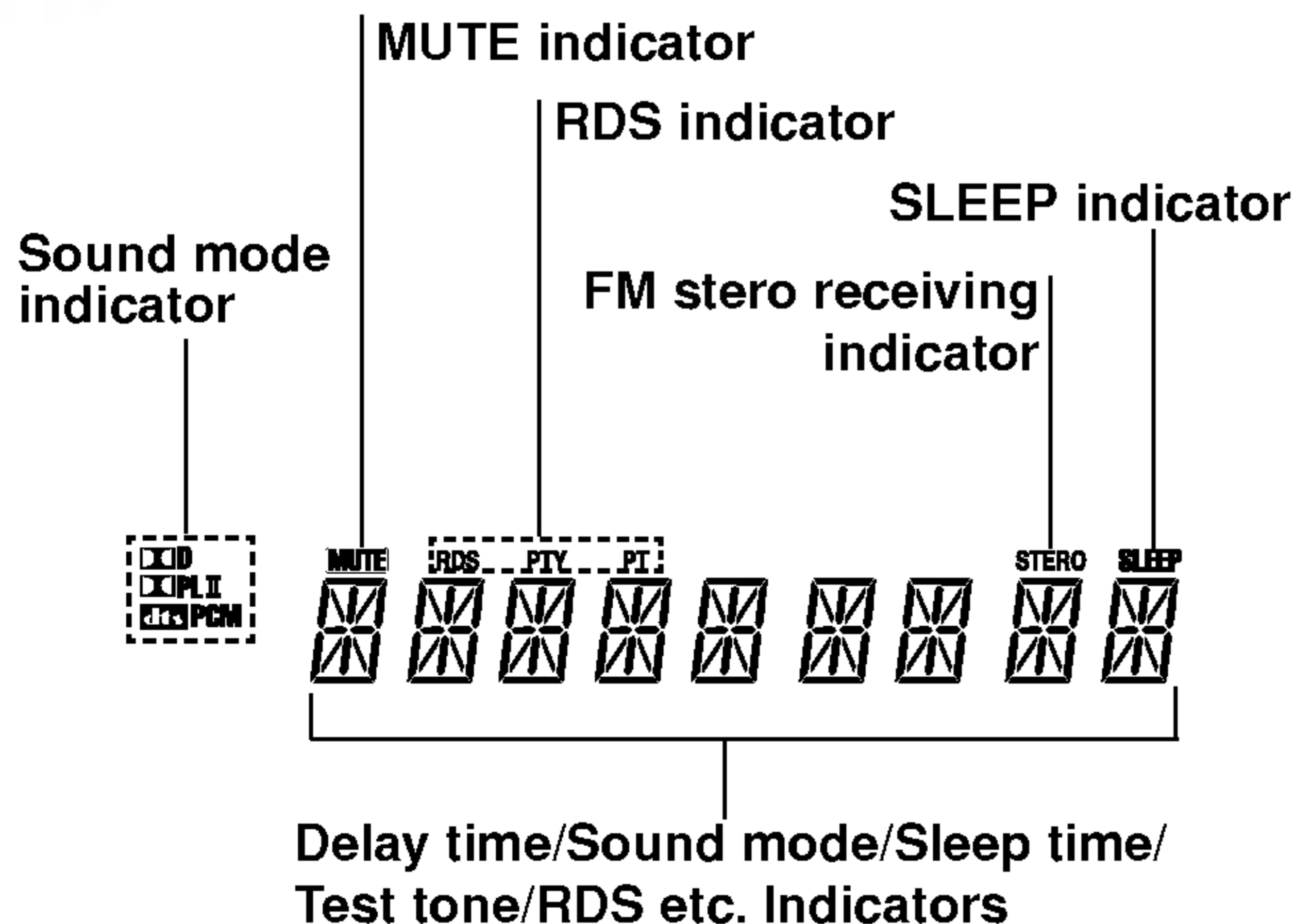

### Remote control

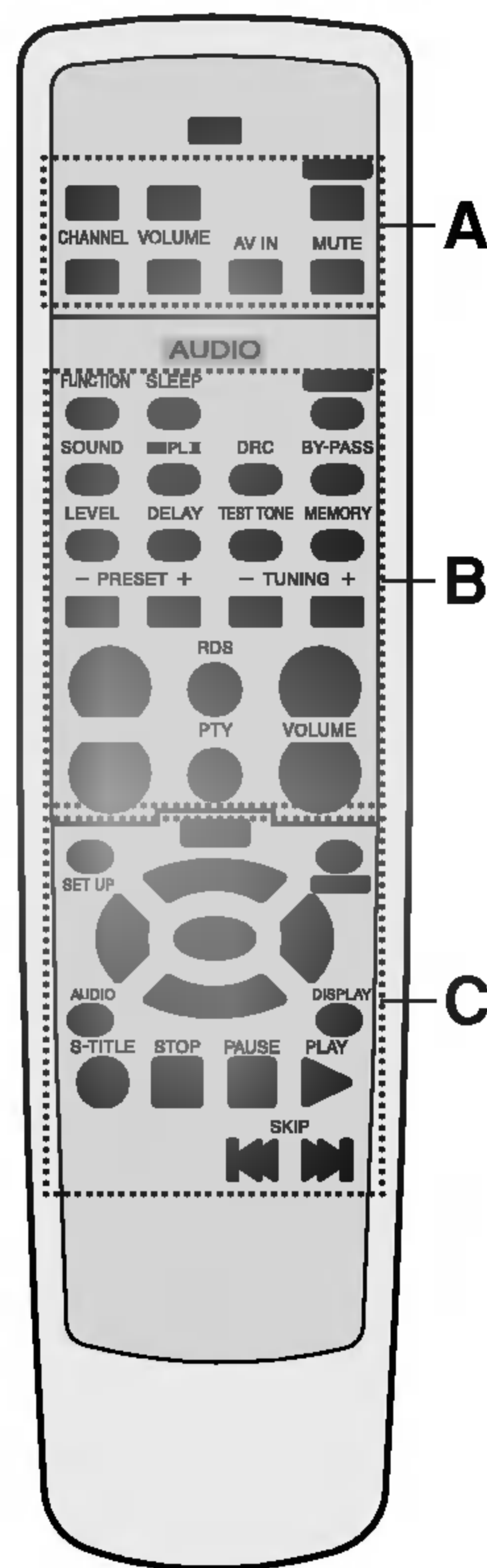

#### A. TV control buttons (LG brand only)

- CHANNEL(+/-) buttons
- VOLUME(+/-) buttons
- POWER button
- AV INPUT button
- MUTE button

#### B. AUDIO control buttons

- FUNCTION button
- SLEEP button
- POWER button
- SOUND (sound mode) button
- DOLBY PRO LOGIC II (DPL II) button
- DRC button
- BY-PASS button
- LEVEL button
- DELAY button
- TEST TONE button
- MEMORY button
- CURSOR(▲/▼/◀/▶) buttons
- PRESET (-/+) buttons
- TUNING (-/+) buttons
- MO./ST. button
- MUTE button
- RDS (OPTIONAL) button
- PTY (OPTIONAL) button
- VOLUME (+/-) buttons

#### C. DVD control buttons

- SET UP button
- POWER button
- CURSOR(▲/▼/◀/▶) buttons
- ENTER button
- AUDIO button
- DISPLAY button
- SUB TITLE(S-TITLE) button
- STOP button
- PAUSE button
- PLAY button
- SKIP(◀◀/▶▶) buttons

### Controlling TV with the remote control

The remote control can operate your TV's functions.(LG brand only)

- Hold POWER and press CHANNEL+ or CHANNEL- button repeatedly until turn the TV on or off.

### Controlling DVDs with the remote control

The remote control can operate your DVD's functions.

- Hold POWER and press CURSOR(C: ▲) button repeatedly until turn the DVD on or off.

#### Brand of controllable DVDs:

LG, JVC, Hitachi, Panasonic, SSE, Phillips, Sharp, Sony, Toshiba.

## Speaker Positioning

In the case of normal position use the 5 speakers (2 front speakers, center speaker and 2 rear speakers).

- **Front speakers**

According to your listening position set up the speakers for equal distance. And by hearing position set up the interval between speakers to 45 degree.

- **Center speaker**

It is ideal that the center speakers and front speakers are same height. But normally place it above or below the television.

- **Rear speakers**

Place left and right behind the listening area. These speakers recreate sound motion and atmosphere required for surround playback. For best results, do not install the rear speakers too far behind the listening position and install them at or above the level of the listener's ears. It is also effective to direct the rear speakers towards a wall or ceiling to further disperse the sound.

In the case of a smaller room size, if the audience is near to the rear wall set the rear speakers opposite each other, and set the rear speakers above 60 - 90 cm than the listener's ears.

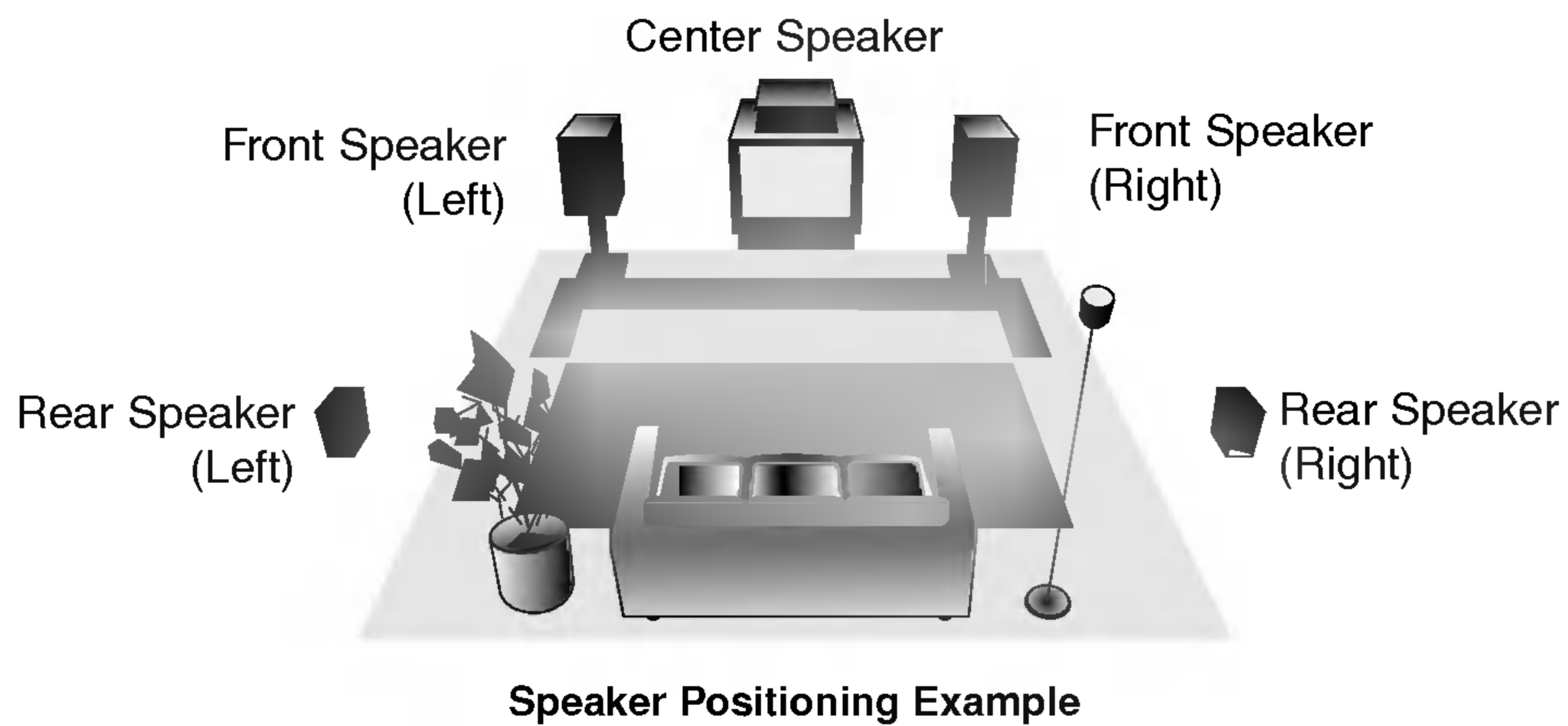

## Connections

### Speaker System Connection

Connect the speakers using the supplied speaker cords by matching the colors of the terminals and those of the cords. To obtain the best possible surround sound, adjust the speaker parameters (distance, level, etc.).

#### Notes

- Be sure to match the speaker cord to the appropriate terminal on the components: + to + and – to –. If the cords are reversed, the sound will be distorted and will lack base.
- If you use front speakers with low maximum input rating, adjust the volume carefully to avoid excessive output on the speakers.
- Do not disassemble the front cover of supplied speaker.

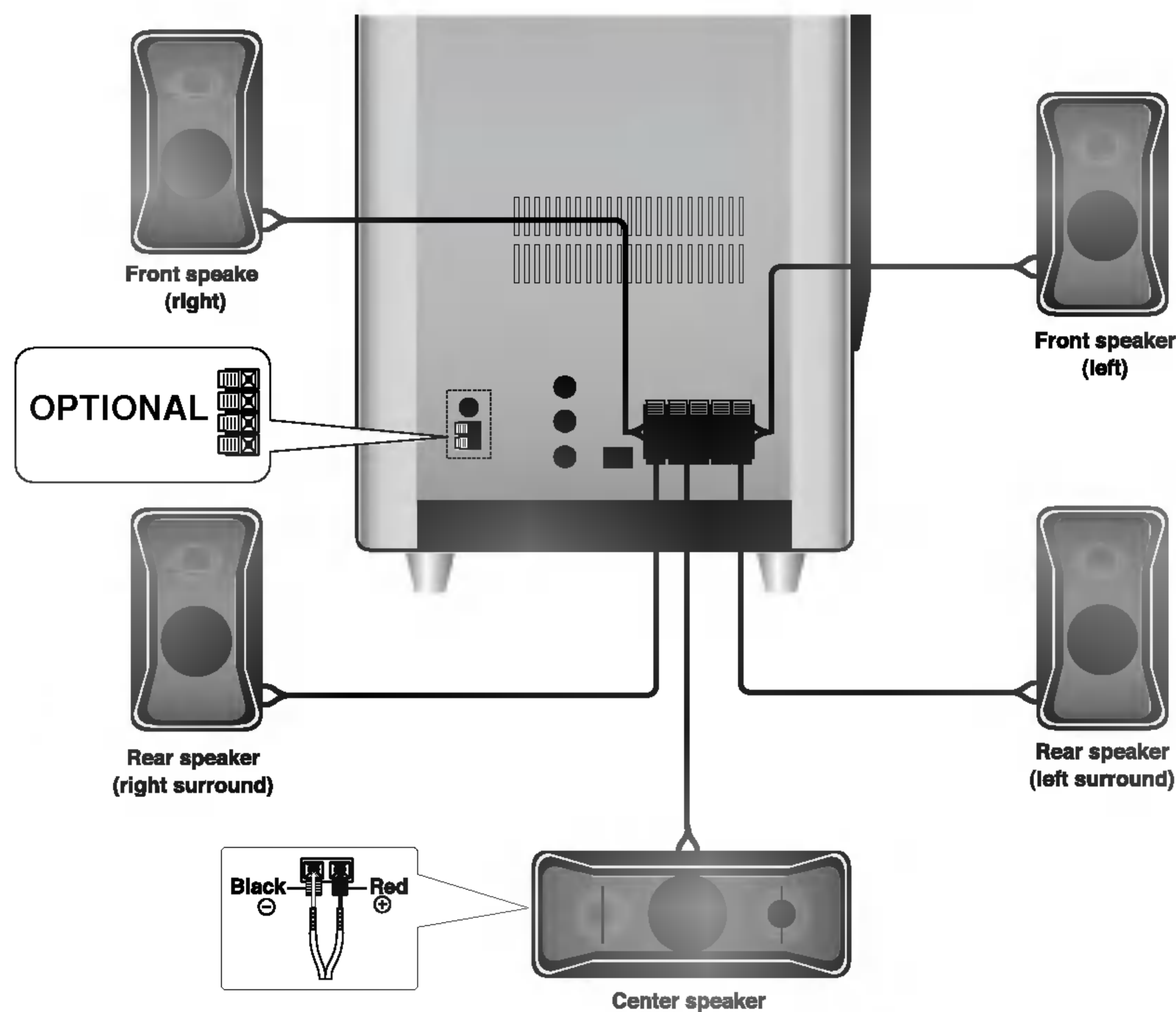

### Antenna (Aerial) Connections

Connect the supplied FM/AM antennas for listening to the radio.

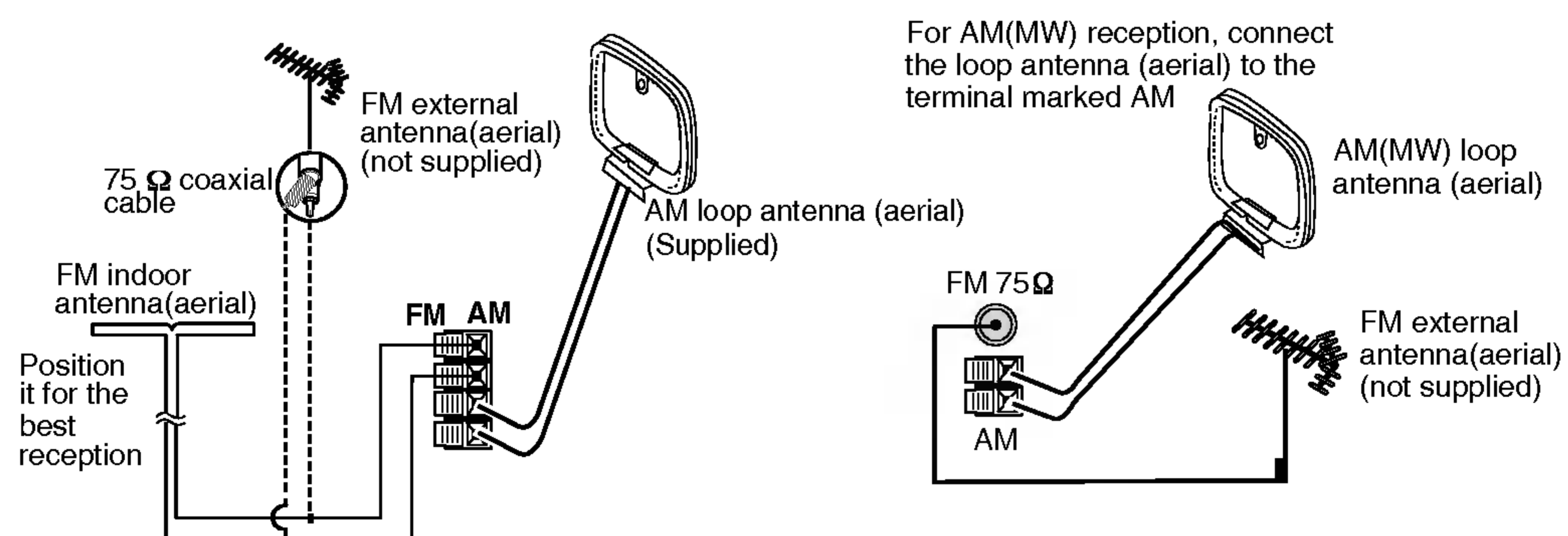

#### Notes

- To prevent noise pickup, keep the AM loop antenna away from the unit and other components.
- Be sure to fully extend the FM wire antenna.
- After connecting the FM wire antenna, keep it as horizontal as possible.

## Connections (Cont'd)

### Connecting to Optional Equipment

#### Connecting to amplifier with two-channel analog stereo or Dolby Surround

Connect Left and Right AUX INPUT jacks on the Dolby Digital Speaker System into the Audio Left and Right OUT jacks on your DVD player, Digital Device or stereo system by the supplied audio cables (**A**).

Connect one of the Dolby Digital Speaker System DIGITAL AUDIO OUT jacks (OPTICAL **O** or COAXIAL **C**) to the corresponding out jack on your DVD player, Digital Device or Stereo system. Use an optional digital (optical **O** or coaxial **C**) audio cable.

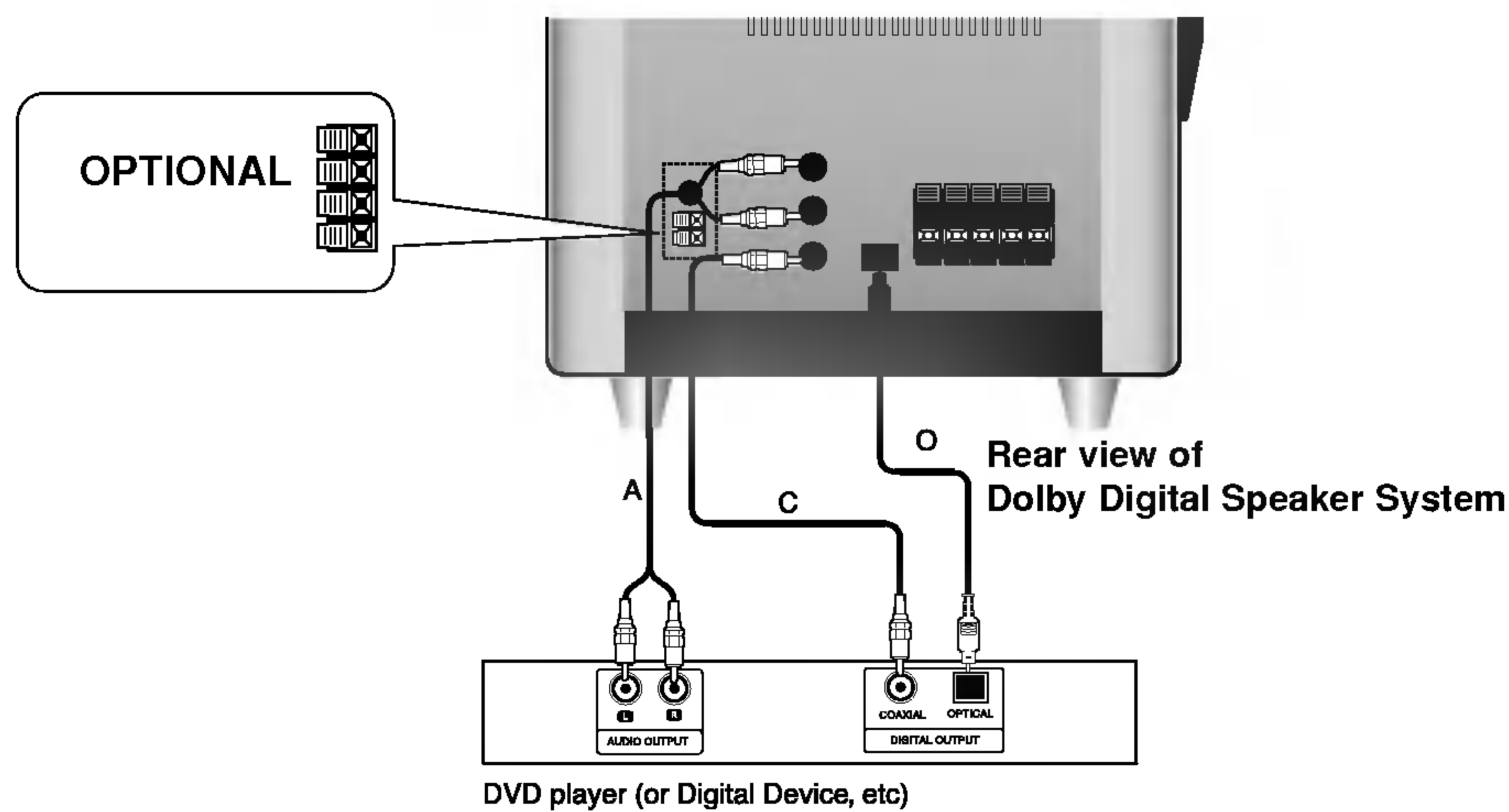

### Display Information about External Digital Input Signal

This display appears depending on the change of the external digital input signal.

<b>UNLOCK DISPLAY</b>	appears when the problem gets in external digital input while normally operating in optical or coaxial function. It could be displayed instantaneously according to the external system quality while operating in switching audio or in skip, open and channel up/down.
<b>CHANNEL DISPLAY</b>	appears when Audio coding mode is changed or when the stream information is changed or the function mode is switched.
1+1	ch1, ch2
1/0	C
2/0	L, R
3/0	L, R, C
2/1	L, R, S(Mono Surround)
2/2	L, R, Ls, Rs
3/1	L, R, C, S(Mono Surround)
3/2	L, R, C, Ls, Rs
.1	LFE signal, no LFE signal

## Presetting the radio stations

### Note

Adjust POWER switch on the backpanel to select ON before operation

You can preset 50 stations for FM and AM. Before tuning, make sure that you have turned down the volume to the minimum.

### 1 Press SELECT (or FUNCTION on the remote control) to select the frequency (AM or FM) you want.

Every time you press this button, AM and FM changes alternately.

### 2 Press TUNING (-/+) until the frequency indication starts to change.

### Notes

#### • Automatic Tuning

- Press TUNING (-/+) for more than 0.5 seconds.
- Scanning stops when the unit tunes in a station.

#### • Manual Tuning

- Press TUNING (-/+) briefly and repeatedly.

### 3 Press MEMORY.

A preset number will flash in the display window.

### 4 Press PRESET (-/+) to select the preset number you want.

### 5 Press MEMORY.

- The station is stored.

### 6 Repeat steps 2 to 5 to store other stations.

### To clear all the memorized stations

Press and hold MEMORY for about two seconds, "MEM CLEAR" appears on the display window and then press MEMORY, the stations are cleared.

### For your reference

If all stations have already been entered, FULL message will appear in the display window for a moment and then a preset number will blink. To change the preset number, follow the steps 4-5.

### To recall presets

Press and hold PRESET (-/+) until the desired preset number appears or press it repeatedly.

## Listening to the radio

### 1 Press SELECT (or FUNCTION on the remote control) to select the frequency (AM or FM) you want.

Every time you press this button, AM and FM changes alternately.

The last received station is tuned in.

### 2 Press PRESET (-/+) repeatedly to select the preset station you want.

- Each time you press the button, the unit tunes in one preset station at a time.

### 3 Adjust the volum by pressing VOLUME (-/+) repeatedly.

### To listen to non-preset radio stations

- Use manual or automatic tuning in step 2.
- For automatic tuning, press and hold TUNING (-/+).

### To turn off the radio

Press POWER to turn the unit off or select another function mode.

### For your reference

#### • If an FM program is noisy

Press MO./ST. so that "STEREO" disappears on the display window. There will be no stereo effect, but the reception will be improved. Press MO./ST again to restore the stereo effect.

#### • To improve reception

Repose the supplied antennas.



## RDS Function - OPTIONAL

### About RDS

This unit is equipped with RDS (Radio Data System), which brings a wide range of information from FM radio. RDS is a system for transmitting station call signs or network information, a description of station programme type text message about the station or specifics of musical selection and the correct time.

### RDS Tuning

When a FM station containing RDS data is tuned in, the unit will automatically display the station's call sign and the RDS indicator will light in the Display Window as well as indicators for the programme type recognition (PTY), Radio Text (RT), Clock Time (CT) and RDS service programme (PS) if transmitted by the station.

### RDS Display Options

The RDS system is capable of transmitting a wide variety of information in addition to the initial call sign that appears when a station is first tuned. In normal RDS operation the display will indicate the station name, broadcast network or call letters. Pressing **RDS** on the front panel enables you to cycle through the various data types in the sequence:

(PS → FREQUENCY → PTY → RT → CT)

- **PTY (Programme type recognition)**- The programme type is shown on the display window.
- **RT (Radio text recognition)**- The radio station's name is displayed on the display window.
- **CT (Time controlled by the channel)**- Enable the unit to receive the actual time and show it on the display window.
- **PS (Programme Service name)**- The programme title is displayed on the display window.

#### Note

Some RDS stations may not choose to include some of these additional features. If the data required for the selected mode is not being transmitted, the Display Window will show a **PTY NONE**, **RT NONE**, **CT NONE**, **PS NONE** message.

### Programme Search (PTY)

A major benefit of RDS is its ability to encode broadcasts with Programme Type (PTY) codes that indicate the type of material being broadcast. The following list shows the abbreviations used to indicate each PTY along with an explanation of the PTY.

NEWS	News
AFFAIRS	Current Affairs
INFO	Information
SPORT	Sports
EDUCATE	Educational
DRAMA	Drama
CULTURE	Culture
SCIENCE	Science
VARIED	Varied Speech Programme
POP M	Popular Music
ROCK M	Rock Music
EASY M	Easy Listening Music
LIGHT M	Classical Music
CLASSICS	Serious Classical Music
OTHER M	Other Music
WEATHER	Weather Information
FINANCE	Financial Programmes
CHILDREN	Children's Programmes
SOCIAL	Social Affairs Programmes
RELIGION	Religious Broadcasts
PHONE IN	Phone-In Programmes
TRAVEL	Travel and Touring
LEISURE	Leisure and Hobby
JAZZ	Jazz Music
COUNTRY	Country Music
NATION M	National Music
OLDIES	Oldies Music
FOLK M	Folk Music
DOCUMENT	Documentary Programmes
TEST	Station Alarm Test Message
ALARM 1	Emergency Broadcast Information

You may search for a specific Programme Type (PTY) by following these steps:

**1** Press **SELECT** (or **FUNCTION** on the remote control) to select FM mode.

**2** Select a desired station by pressing **TUNING (-/+)**.

When the RDS transmission is received, the display shows the program service name (PS) after RDS indicator appears.

**3** Press the **RDS** to select PTY mode.

**4** To search for a different PTY, press the **PRESET (-/+)** while the last PTY in use is still displayed to scroll through the list of available PTY types.

**5** When the PTY is selected, press the **TUNING (-/+)** within 5 seconds.

The unit will go into an automatic search mode and attempt to find the next station with acceptable signal strength that matches the desired PTY type.

## Speaker Setup

### Delay Time Setting

In Dolby Digital or Dolby Pro Logic mode it is assumed that the distance from the listener to each of the speakers is equal. If not then setting the delay times of the center or rear speakers the sound will be heard simultaneously by the listener.

The interval from the speakers to the listener. If the distance from the listener to each speakers is same, in the Dolby Digital and Dolby Pro Logic mode the delay time of each speakers is as following.

#### In Dolby Digital mode

Center delay time : 0 ~ 5ms

Rear delay time: 0 ~ 15ms

#### In Dolby Pro Logic mode

Center delay time : cannot setting

If the rear delay time is set in Dolby Digital mode, in the Dolby Pro Logic mode the delay time will be automatically set.

The delay time is 1 msec per 30 cm.

If the center and rear speakers are further than the front speakers from the listener, the delay time will be at minimum.

### Surround delay time setting

If the distance of Ds is equal to or longer than the DF in the left figure, set the Surround Delay Time as 0ms.

Otherwise, change the setting according to the below.

Ex) If the distance from front speakers to the listener is 3 m and from rear speakers from the listener is 1.5 m, in the Dolby Digital mode the rear delay time is 5 msec.  
 $3\text{m (DF)} - 1.5\text{m (Ds)} = 1.5\text{m (B)}$   
 $1.5\text{m (B)} = 150\text{cm} / 30\text{cm} = 5\text{msec}$

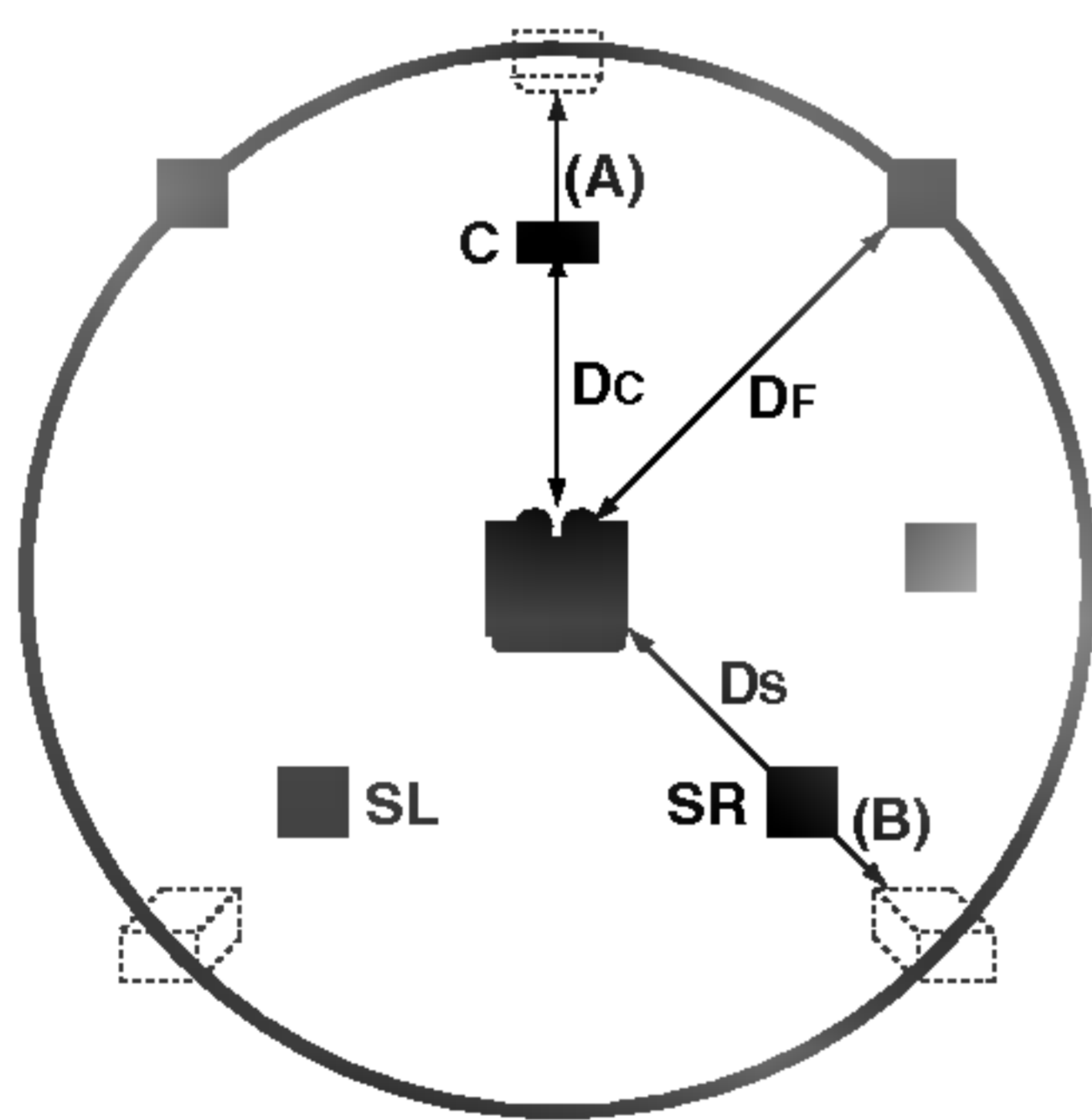

In Dolby Pro Logic II (Surround delay time):

- Prologic: 15 ~ 30msec
- Movie: 10 ~ 25msec
- Music: 0 ~ 15msec
- Matrix: 0 ~ 15msec

### Center delay time setting (Dolby Digital mode only)

If the distance of DF is equal to the distance of DC in the left figure, set the Center Delay Time as 0ms. Otherwise, change the setting according to the table below.

Ex) If the distance from the front speakers to the listener is 3m and from the center speaker to the listener is 2.4m, the center delay time is 2msec.

$3\text{m (DF)} - 2.4\text{m (DC)} = 60\text{cm (A)}$

$60\text{cm (A)} / 30\text{cm} = 2\text{msec}$

### Setting the delay time in the Dolby Digital and Dolby Pro Logic (II) mode

#### 1 Press DELAY.

The current surround delay time appears in the display window.

You can select center delay time by pressing ◀/▶ in the Dolby Digital mode only.

#### 2 Press ▲/▼ to change the delay time.

#### 3 If setting is complete, press DELAY.

#### Note

You can adjust the center delay time only in the Dolby Digital mode and its delay time appears.

### Center Width (MUSIC mode of Dolby Pro Logic II only)

This control allows center-channel sounds to be positioned between the center speaker and the left/right speakers over a range of eight steps. Step "3" uses a combination of all three front speakers to give the best vocal imaging and most seamless soundstage presentation, and is recommended for most recordings. Step "0" places all center sound in the center speaker. Step "7" places all center sound equally in the left/right speakers, just as in conventional stereo.

### DIMENSE (MUSIC mode of Dolby Pro Logic II only)

This control allows the user to gradually adjust the soundfield either towards the front or the rear. This can be useful to help achieve the desired balance from all the speakers with certain recordings that may contain either too much or too little spatial effect. Step "0" is the recommended setting, which has no effect on the sound. Steps 1, 2, and 3 gradually move the sound forward, and steps -1, -2, and -3 move the sound towards the surrounds.

### PANORAMA (MUSIC mode of Dolby Pro Logic II only)

This control extends the front stereo image to include the surround speakers for an exciting "wraparound" effect with side-wall imaging. It is particularly effective for recordings which have strong left- or right-channel elements in the mix, as these are detected and accentuated by the Panorama process.

## Mini Glossary for Sound Mode

### **dtS**

Allows you to enjoy 5.1 (or 6) discrete channels of high quality digital audio from DTS program sources bearing the trademark such as discs, DVD and compact discs, etc. DTS Digital Surround delivers up to 6 channels of transparent audio (which means identical to the original masters) and results in exceptional clarity throughout a true 360 degree sound field. The term DTS is a trademark of DTS Technology, LLC. Manufactured under license from DTS Technology, LLC.

### **DOLBY DIGITAL**

The Dolby Digital surround format lets you enjoy up to 5.1 channels of digital surround sound from a Dolby Digital program source. If you play DVDs with "DOLBY DIGITAL" mark, you can enjoy even better sound quality, greater spatial accuracy, and improved dynamic range.

### **HALL 1**

When playing recordings of live music and classic, this mode provides a feeling similar to actually being in a small concert hall.

### **HALL 2**

When playing recordings of live music and classic, this mode provides a feeling similar to actually being in a large concert hall.

### **THEATER**

This mode provides a three dimensional effect similar to that of movie theater.

### **DOLBY PRO LOGIC (II)**

Dolby Pro Logic II creates five full-bandwidth output channels from two-channel sources. This is done using an advanced, high-purity matrix surround decoder that extracts the spatial properties of the original recording without adding any new sounds or tonal colorations.

#### **PROLOGIC mode:**

The Pro Logic Emulation mode offers users the same robust surround processing as original Pro Logic, in case the source content is not of optimum quality, or if there is a desire to hear the program more "as it used to be." When this mode is used, it is called Pro Logic, as before. There is no "Pro Logic I" mode. The Pro Logic emulation mode is optional. Dolby does not require PLII products to use the original Pro Logic decoding algorithm. However, if the DSP contains the original Pro Logic code, and if the product maker would like to use it, this is quite acceptable and even encouraged. A product must not offer both original Pro Logic and the Pro Logic emulation mode.

#### **MOVIE mode:**

The Movie mode is for use with stereo television shows and all programs encoded in Dolby Surround. The result is enhanced soundfield directionality that approaches the quality of discrete 5.1-channel sound.

#### **MUSIC mode:**

The Music mode is for use with any stereo music recordings, and provides a wide and deep sound space. The Music mode includes controls that allow the sound to be tailored to individual listening tastes.

#### **MATRIX mode:**

The Matrix mode is the same as the Music mode except that the directional enhancement logic is turned off. It may be used to enhance mono signals by making them seem "larger." The Matrix mode may also find use in auto systems, where the fluctuations from poor FM stereo reception can otherwise cause disturbing surround signals from a logic decoder. The ultimate "cure" for poor FM stereo reception may be simply to force the audio to mono.

### **SURROUND OFF (2CH STEREO)**

Outputs the sound from the front left and right speakers and subwoofer. Standard two channel (stereo) sources completely bypass the sound field processing. This allows you to play any source using only the front left and right speakers and subwoofer. **You can select SURROUND OFF by pressing BY-PASS on the remote control.**

### **Dynamic Range Control (DRC)**

With the DVD\*1 format, you can hear a program's soundtrack in the most accurate and realistic presentation possible, thanks to digital audio technology. However, you may wish to compress the dynamic range of the audio output (the difference between the loudest sounds and the quietest ones). Then, you may listen to a movie at a lower volume without losing clarity of sound. **You can select DRC ON or OFF by pressing DRC on the remote control.**

\*1: Dolby Digital only

## Sound Adjustment

### Sound Mode

**When PCM indicator is only displayed in the display window:**

Each time you press **SOUND** button, the sound mode is changed as the following order;

PRO LOGIC → HALL1 → HALL2 → THEATER



Each time you press **PLII** button, the sound mode of Pro Logic II is changed as the following order;



PRO LOGIC → MOVIE → MUSIC → MATRIX



#### Tip

You can select SURROUND OFF (2CH STEREO) mode by pressing BY-PASS button.

**For your reference**

- You can identify the encoding format of program software by looking at its packaging.
  - Dolby Digital discs are labeled with the  logo.
  - Dolby Surround encoded programs are labeled with the  logo.
  - DTS Digital Surround discs are marked with DTS.

### Sound Level

You can set the sound level of the desired channel.

#### 1 Press LEVEL.

The level indicator will appear in the display window.

#### 2 Press ◀/▶ to select a desired speaker to set.

Each time you press the ◀/▶ button, it is changed as the following order;

FL (Front Left) → C (Center) → FR (Front Right) →  
SR (Surround Right) → SL (Surround Left) →  
SW (Subwoofer) → FL (Front Left)

- On the 2 channel stereo mode, you can only select the SW (Subwoofer).

#### 3 Press ▲/▼ to adjust the sound level of the selected channel. (-6dB ~ +6dB)

#### 4 Repeat step 2-3 and adjust the sound level of the other channels.

#### 5 If setting is complete, press LEVEL.

### Mute

**Press MUTE to mute your unit.**

You can mute your unit in order, for example, to answer the telephone, "MUTE" indicator flashes in the Display Window.

### Test Tone

This function allows you can easily adjust the sound balance of the speakers from the listener's position.

#### 1 Select the test tone mode by pressing TEST TONE.

- A hiss noise comes out for 2 seconds from each speakers in the following order;  
FL (Front Left) → C (Center) → FR (Front Right) →  
SR (Surround Right) → SL (Surround Left) →  
SW (Subwoofer) → FL (Front Left)

#### 2 You can adjust the sound level during operating the test tone, first press LEVEL then press ▲/▼ buttons, so that all speaker's sound level is same from the listener's position.

- During operating the test tone, if you adjust the sound level, it will be paused in the current speaker channel.

#### 3 If setting is complete, press TEST TONE.

### Sleep Timer Setting

You can set the Surround Sound System to turn off automatically at a specified time.

#### 1 Press SLEEP to set the desired sleep time.

The SLEEP indicator and sleep time appears in the display window.

#### 2 Each time you press SLEEP the setting changes in the following order.

SLEEP 180 → 150 → 120 → 90 → 80 → 70 → 60 → 50 → 40 →  
30 → 20 → 10 → OFF

#### Note

**You can check the time remaining before the Surround Sound System turns off.**

Press SLEEP. The remaining time appears in the display window.

### Selecting input source

You can use DVDs or other units connected to the AUX INPUT(R/L), COAXIAL INPUT or OPTICAL INPUT connector. Refer to the owners manual supplied with the unit for further information on the operation.

**Press SELECT repeatedly on the front panel or press FUNCTION repeatedly on the remote control to select the desired input source.**

Each time you press this button, the mode of the function changes in the following sequence:

- **ANALOG:** for selecting the analog signal from AUX INPUT (R/L) Connectors.
- **OPTICAL:** for selecting the digital signal from OPTICAL IN Connector.
- **COAXIAL:** for selecting the digital signal from COAXIAL IN Connector.

#### Note

The Optical input function is available only when the other unit's Sampling Frequency is 32 ~ 48kHz.

## Before Requesting Service

Symptom	Cause	Correction
No sound.	<ul style="list-style-type: none"><li>• Speaker cords are not connected securely.</li></ul>	<ul style="list-style-type: none"><li>• Connect them securely.</li></ul>
	<ul style="list-style-type: none"><li>• Speaker cords are not connected correctly.</li></ul>	<ul style="list-style-type: none"><li>• Connect them correctly, that is L (left) to L, R (right) to R.</li></ul>
Power is not supplied even though the POWER button is pressed in.	<ul style="list-style-type: none"><li>• The power cord is not plugged in.</li></ul>	<ul style="list-style-type: none"><li>• Plug the power cord into an AC outlet.</li></ul>
The remote control does not work properly.	<ul style="list-style-type: none"><li>• The remote control is not pointed at the remote sensor of this unit.</li></ul>	<ul style="list-style-type: none"><li>• Point the remote control at the remote sensor of this unit.</li></ul>
	<ul style="list-style-type: none"><li>• The remote control is too far from this unit.</li></ul>	<ul style="list-style-type: none"><li>• Operate the remote control within about 23 ft (7 m).</li></ul>
	<ul style="list-style-type: none"><li>• There is an obstacle in the path of the remote control and this unit.</li></ul>	<ul style="list-style-type: none"><li>• Remove the obstacle.</li></ul>
	<ul style="list-style-type: none"><li>• The batteries in the remote control are exhausted.</li></ul>	<ul style="list-style-type: none"><li>• Replace the batteries with new ones.</li></ul>

## Specification

Power supply		Refer to the main label		
Power consumption		60 W		
Mass		10 kg		
External dimensions (W x H x D)		246 x 430 x 420 mm		
Operating conditions		Temperature: 5°C to 35°C, Operation status: Horizontal		
Frequency response (audio)		120 Hz to 20 kHz		
Signal-to-noise ratio (audio)		More than 75 dB (1 kHz, NOP, W/IHF-A & 20 kHz Filter)		
Harmonic distortion (audio)		1.0 % (1 kHz, at 12W position) (20 kHz LPF/A Filter)		
Surround mode		Front: 60W + 60W (THD 10 %) Center*: 60W Surround*: 60W + 60W (8Ω at 1 kHz, THD 10 %) Subwoofer*: 120W (4Ω at 250 Hz, THD 10 %)		
<b>FM</b>	Tuning Range	87.5 - 108.0 MHz or 65 - 74 MHz, 87.5 - 108.0 MHz		
	Intermediate Frequency	10.7 MHz		
	Signal to Noise Ratio	60/55 dB		
	Frequency Response	140 -10,000 Hz		
<b>AM</b>	Tuning Range	522 - 1611 kHz or 530 - 1610 kHz or 530 - 1720 kHz		
	Intermediate Frequency	450 kHz		
	Signal to Noise Ratio	37 dB		
	Frequency Response	140 - 25,000 Hz		
Inputs		AUX, COAXIAL, OPTICAL AUDIO		
Model		Satellite Speaker (LHS-A4000T)	Center Speaker (LHS-A4000C)	Active Subwoofer (LHS-A4000WA/WD/WX)
Type		2 Way 2 Speaker	2 Way 2 Speaker	1 Way 1 Speaker
Impedance		8 Ω	8 Ω	4 Ω
Frequency Response		120 - 20,000 Hz	120 - 20,000 Hz	40 - 180 Hz
Sound Pressure Level		84 dB/W (1m)	84 dB/W (1m)	82 dB/W (1m)
Rated Input Power		60 W	60 W	120 W
Max. Input Power		120 W	120 W	240 W
Net Dimensions (W x H x D)		100 x 162 x 120 mm	225 x 102 x 120 mm	246 x 430 x 420 mm
Net Weight		0.8 kg	0.9 kg	10 kg

\* Designs and specifications are subject to change without notice.



P/NO : 3834RP0111H