

INSTALLATION/  
OWNER'S MANUAL

**AIR  
CONDITIONER**

Please read this installation manual completely before installing the product.  
Installation work must be performed in accordance with the national wiring standards  
by authorized personnel only.  
Please retain this installation manual for future reference after reading it thoroughly.

***BECON*** HVAC Touch(AC Smart IV)  
PACS4B000



P/NO : MFL68463901

[www.lg.com](http://www.lg.com)



# EXPLANATORY NOTES

## Copyrights

The contents of this AC Smart IV Installation and User Manual are protected by international copyright laws, and the Computer Program Protection Act. The contents of the Installation/User Manual and the programs mentioned herein may only be used under license from LG Electronics in strict adherence to the user agreement.

You may not reproduce or distribute, by any means, copies of this Installation and User Manual, or any part of it, without prior approval from LG Electronics.

Copyright © 2014 LG Electronics. All rights reserved.

## Registered Trademarks

AC Smart IV is a registered trademark of LG Electronics. All other products and company names are trademarks of their respective owners and are used for illustrative purposes only.

# Product Features

## Convenience

- **Auto-changeover**  
Automatically switches the indoor unit into the correct mode to optimize space comfort.
- **Web access**  
Allows distributed control from a remote location.
- **Visual and e-mail alarm notification**  
Immediately indicates when a system is not operating at optimal conditions.
- **Visual Navigation**  
Allows for accessing unit data by navigating uploaded floorplans.

## Energy Savings

- **Scheduling**  
Conditions the space only when necessary.
- **Setpoint Range Limit**  
Prevents the setpoint from being set to extremes that can result in overcooling or overheating of the space.
- **Remote Controller Lock**  
Prevents users from changing indoor unit operation.
- **Setback**  
Allows indoor units to be shut off during unoccupied periods with an override feature to keep interior temperatures from reaching extremes.
- **Time Limit**  
Allows a unit to be turned on during unoccupied times and automatically shut down after a specified amount of run time.
- **Peak/Demand Control**  
Allows for electronically limiting power usage.

## Integration

- **Interlocking**  
Allows interlocked operation between devices or between digital inputs and outputs on the AC Smart and devices.

## How to Use This Guide

Please read from beginning to end this User Manual before using AC Smart IV. Store this guide so that is also easily accessible.

## Notations Used In This Guide

- Control buttons displayed within the system are marked by boldface text in square brackets (**[ ]**).  
Example: **[OK]**, **[Save]**
- Option titles displayed in the program are marked by boldface text.  
Example: **Start**, **Programs**
- Keyboard strokes used by the system are marked by boldface text in angle brackets (**< >**).  
Example: **<Esc>**

 MEMO

# TABLE OF CONTENTS

## 1 SAFETY PRECAUTIONS

---

## 7 PREPARATION

---

- 7 AC Smart IV Overview
- 7 Components
- 8 Product Specifications
- 9 Features and Functions
- 10 Installation and Configuration
  - 10 – Installation
  - 19 – Configure Remote Shutdown Feature
- 20 Information Input Method

## 21 STARTING

---

- 21 Turning on/off the screen
  - 21 – Turning on the screen
  - 21 – Turning off the screen
- 22 Rebooting
- 22 Login and logout

## 23 Troubleshoot

---

- 23 Control Codes
- 23 Error Codes
  - 23 – Indoor Device, ERV or ERV DX, AWHP(Hydro kit), AHU error
  - 25 – Outdoor Unit Errors
  - 27 – MultiV 20 Hp, 30 Hp, 40 Hp, error
  - 29 – Super Errors
  - 30 – Central Controller Errors
- 31 Pre-Tech Support Checklist
- 31 OPEN SOURCE SOFTWARE NOTICE

 MEMO

# SAFETY PRECAUTIONS

- This product must be installed by an installation professional from an LG authorized service center.
- Any issues stemming from an installation by an unauthorized person is the responsibility of the user and will not be covered by warranty.
- The following safety precautions are to prevent any unforeseen dangers or damage.
- This product has been designed for business use, or for areas outside the home, and has passed the Electromagnetic Interference Test.



## WARNING

It can result in serious injury or death when the directions are ignored.



## CAUTION

It can result in minor injury or product damage when the directions are ignored.



## WARNING

### Installation

- **To reinstall the product, please contact the dealer from where you purchased the product, or a service center for reinstallation service.**
  - Installation of the product by an unauthorized person may result in fire, electric shock, explosion, injury, or a malfunctioning of the product.
- **Do not twist or damage the power cord.**
  - It may cause fire or electric shock.
- **For electrical work, please contact the dealer from where you purchased the product, or a service center.**
  - Disassembly or repair by an unauthorized person may result in fire or electric shock.
- **Install the product in an area shielded from rain.**
  - If water gets into the product, it may malfunction.
- **Do not install the product in a humid area.**
  - If the product is damp, it may malfunction.
- **For installation of the product, please contact the dealer from where you purchased the product, or a service center.**
  - Installation of the product by an unauthorized person may result in fire, electric shock, explosion, injury, or a malfunctioning of the product.

- **For electrical work, please have an electrician do the work based on the installation manual and specified circuit diagram.**
  - Using an unsuitable cord, or having a non-professional work on the electricals may result in fire or electrical shock.
- **Do not place the product near a fire source.**
  - It may result in the product catching fire.
- **If the product is installed in a hospital or a communication base station, provide sufficient protective equipment against electrical noise.**
  - The product may malfunction or other products may work abnormally.
- **Securely install the product.**
  - If the product is not secured during installation, it may fall or malfunction.
- **Read the manual thoroughly to correctly install the product.**
  - If not, an incorrect installation may cause fire or electric shock.
- **When wiring the product, do not use a non-standard cable, nor extend the cable excessively.**
  - It may cause a fire or electric shock.
- **Securely install the power cord and communication cable.**
  - An unsecure installation may result in a fire or electric shock.
- **Do not connect the power cord to the communication terminal.**
  - It may cause a fire, electric shock, or a product malfunction.
- **Do not install the product in an area near combustible gas.**
  - It may result in fire, electric shock, explosion, injury, or a malfunctioning of the product.

## Use

- **Do not place a heavy object on the power cord.**
  - It may cause a fire or electric shock.
- **Do not change or extend the power cord arbitrarily.**
  - It may cause a fire or electric shock.
- **Use the cord specific to the product.**
  - Using an unauthorized non-standard cord may result in a fire or electric shock.
- **Do not use a heat device near the power cord.**
  - It may cause a fire or electric shock.
- **Ensure that water never gets into the product.**
  - It can result in an electric shock, or the product may malfunction.
- **Do not place any container with liquid on the product.**
  - The product may malfunction.

- **Do not touch the product with wet hands.**
  - It may cause a fire or electric shock.
- **Use standard components.**
  - Use of an unauthorized product may result in fire, electric shock, explosion, injury, or a malfunctioning of the product.
- **If the product has been submerged in water, you should contact a service center.**
  - It may cause a fire or electric shock.
- **Do not shock the product.**
  - The product may malfunction.
- **Do not store or use any combustible gas or flammable substances near the product.**
  - It may cause a fire, or a product malfunction.
- **Do not disassemble, repair, or revamp the product arbitrarily.**
  - It may cause a fire or electric shock.
- **Children and the elderly should use the product under the supervision of a guardian.**
  - Carelessness may cause an accident, or the product to malfunction.
- **The guardian should prevent children from accessing the product.**
  - The product may be damaged or it may fall, causing injury to children.
- **Keep in mind the operating temperature range specified in the manual. if there is no operating temperature range in the manual, use the product between 0 and 40 °C (32 and 104 °F).**
  - If the product is used outside this range, the product may be severely damaged.
- **Do not press the switch or button with a sharp object.**
  - It can result in an electric shock, or the product may malfunction.
- **Do not wire the product while it is turned on.**
  - It may cause a fire or electric shock.
- **If the product sounds or smells different, stop using the product.**
  - It may cause a fire or electric shock.
- **Do not place a heavy object on the product.**
  - The product may malfunction.
- **Do not spray water on the product, or clean it with a water-soaked cloth.**
  - It may cause a fire or electric shock.
- **Do not use the product for the preservation of animals and plants, precision instruments, art pieces, or for other special purposes.**
  - It may cause property damage.
- **Dispose the packing material safely.**
  - The packing material may result in personal injuries.



## CAUTION

### Installation

- **Securely install the product in an area where the weight of the product can be supported.**
  - The product may fall and be destroyed.
- **Do not use the product where there is oil, steam, or sulfuric gas.**
  - It may effect the product's performance, or damage it.
- **Check the rated power capacity.**
  - It may cause a fire, or a product malfunction.
- **Use the adapter provided with the product or power from a class 2 24 V~ transformer, depending on model.**
  - If a non-standard adapter is used, the product may malfunction. The adaptor is not provided with the AC Smart IV package sold in the U.S.
- **Be careful not to drop or damage the product when moving it.**
  - The product may malfunction or the person may sustain an injury.
- **Ensure that the cord is connected securely to prevent dew, water, or insects from getting into the product.**
  - If a foreign substance gets inside, it may cause an electric shock or the product may malfunction.

### Use

- **Clean the product with a soft cloth, but not with a solvent-based detergent.**
  - The use of a solvent-based detergent may cause a fire or deform the product.
- **Do not touch the panel using a pointy or sharp object.**
  - It can result in an electric shock, or the product may malfunction.
- **Do not let the product come into contact with a metal substance.**
  - The product may malfunction.
- **When sterilizing or disinfecting, stop using the product.**
  - The product may work abnormally.
- **Do not touch inside the product.**
  - The product may malfunction.
- **Check the condition of the product after using the product for an extended period of time.**
  - If the product is used for an extended period of time, the product's condition may be worsen, causing injury to the user.
- **Do not leave the product near a flower base, water bottle, or any other liquids.**
  - It may cause a fire or electric shock.

- **If the liquid crystal of the product is broken, please do not let your skin such as face or hands contact with.**
  - Personal injury or property damage may occur.

- **Transformer selection:**

- Select an insulating product that complies with IEC61558-2-6 and NEC Class 2.
- In addition, consider the combined power consumption of the modules, accessories, and field devices installed for the selection of an appropriate transformer.

Main module current: 24 V~, 850 mA

- Use the provided adaptor when using DC 12 V. The adaptor is not provided with the AC Smart IV package sold in the U.S.

**Class A device****NOTES**

This equipment has been tested and found to comply with the limits for a Class A digital device, pursuant to part 15 of the FCC Rules.

These limits are designed to provide reasonable protection against harmful interference when the equipment is operated in a commercial environment.

This equipment generates, uses, and can radiate radio frequency energy and, if not installed and used in accordance with the instruction manual, may cause harmful interference to radio communications. Operation of this equipment in a residential area is likely to cause harmful interference in which case the user will be required to correct the interference at his own expense.

**CAUTION**

Changes or modifications not expressly approved by the manufacturer responsible for compliance could void the user's authority to operate the equipment.

**Disposal of your old appliance**

1. When this crossed-out wheeled bin symbol is attached to a product it means the product is covered by the European Directive 2002/96/EC.
2. All electrical and electronic products should be disposed of separately from the municipal waste stream via designated collection facilities appointed by the government or the local authorities.
3. The correct disposal of your old appliance will help prevent potential negative consequences for the environment and human health.
4. For more detailed information about disposal of your old appliance, please contact your city or/ce, waste disposal service or the shop where you purchased the product.

# PREPARATION

The following provides information on the AC Smart IV components, how to install and configure, and other required information necessary to use the product.

## AC Smart IV Overview

AC Smart IV is a central controller installed in the management office of a building, or in the administration office of a school, to monitor and operate, via touch screen or Web access, the indoor units, ERV (ERV: Energy Recovery Ventilator, ERV DX: Direct Expansion Energy Recovery Ventilator), DI/DOs, DOKITs, AWHPs, AHUs and I/O Modules installed inside the building. AC Smart IV can manage, collectively or individually, the indoor units, ERV, DI/DOs, DOKITs, AWHPs and AHUs for up to 128 devices. (Or the indoor units, ERV, DI/DOs, DOKITs, AWHPs and AHUs for up to 64 devices and 9 I/O Modules)

## Components

The following components are included in the package box. Open the box and verify that all components are included.



AC Smart IV



AC Smart IV  
User's Manual

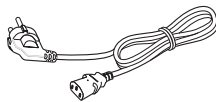

Power Cord



Power Adapter



Quick Guide

Power Cord, Power Adapter and Quick Guide are not provided with the AC Smart IV package sold in the U.S.

**NOTES**

The figures of the components and optionally purchased products shown may differ from the actual components and products.

## Product Specifications

The product specifications for AC Smart IV are as follows.

Item	Specifications
CPU	PCIMX5150D <ul style="list-style-type: none"> <li>• ARM Cortex A8™ core</li> <li>• 800 MHz</li> </ul>
MEMORY	128 x 4 MB (DDR2 SDRAM)
Storage	4GB (INAND FLASH)
LCD	10.2 inch WSVGA (1024 x 600) TFT LCD
Speaker	MONO 300 mW
RS485	2 Ports
USB/SD	<ul style="list-style-type: none"> <li>• MICRO USB 1EA (for external USB memory)</li> <li>• MINI USB 1EA (for service)</li> <li>• SD Card 1EA</li> </ul>
DI	2 Ports
DO	2 Ports
Touch Screen	C-Type Touch Panel
Button Key	Less than 9 seconds (LCD POWER ON/OFF), 10 seconds (SYSTEM RESET)
POWER	DC 12 V (3.33 A), 24 V~
OS	Linux

# Features and Functions

The features and functions of AC Smart IV are as follows.

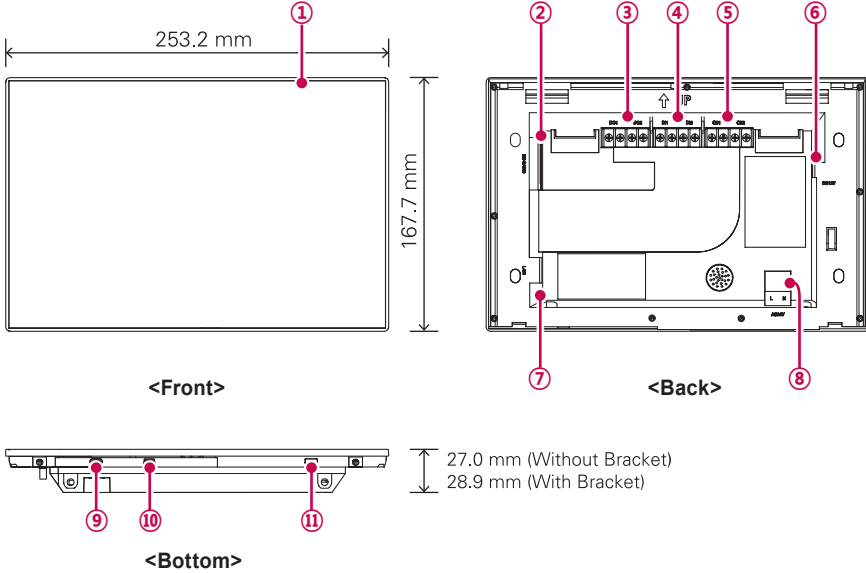

Number	Item	Description
①	Touch Screen	<ul style="list-style-type: none"> <li>• 10.2 inch LCD control panel</li> <li>• AC Smart IV control and information display</li> </ul>
②	SD Memory Slot (for service)	SD card memory slot for software upgrade
③	DO Port	2CH DO port
④	DI Port	2CH DI port
⑤	485 Port	2CH 485 port (CH1: AHU, CH2: devices other than AHU)
⑥	DC 12 V Input Port	DC 12 V power input port
⑦	LAN Port	LAN cable port for Ethernet connection (100Mbps/10Mbps)
⑧	24 V~ Input Port	24 V~ power input port
⑨	Micro USB Port	USB 2.0 to connect USB memory sticks storing floor plans, reports, statistics, etc.
⑩	Mini USB Port (for service)	PC port for software upgrade
⑪	Power ON/OFF	<ul style="list-style-type: none"> <li>• Push less than 10 seconds to control AC Smart IV LCD backlight.</li> <li>• Push 10 seconds or more to reset AC Smart IV.</li> <li>• If you are not going to use AC Smart IV for a long time, it is recommended that the product be turned off to prolong the LCD backlight's life.</li> </ul>

## Installation and Configuration

This chapter explains how to install and configure AC Smart IV.

### Installation

To use AC Smart IV, build an environment for which AC Smart IV can communicate with devices like the indoor unit, ERV, DI/DO, DOKIT, AWHP, AHU and I/O Module. Use AC Smart IV to register those devices.

AC Smart IV should be installed in the following order:

#### **STEP 1. Check the installation environment and configure the device address.**

Check the network configuration against the interfaced devices before installing AC Smart IV and allocate a unique central control address for each connected device.

#### **STEP 2. Connect V-Net devices with AC Smart IV.**

Use an RS485 cable to connect V-Net devices with AC Smart IV.

#### **STEP 3. Login and register the devices.**

Login to AC Smart IV and register those devices that have their address set.



### CAUTION

The installation of AC Smart IV must be done by a professional. Be sure to contact a qualified engineer for the installation. If you have a question or request regarding the installation, contact an installation professional at an authorized LG service center or LG Electronics.

### Check the installation environment and configure the device address

AC Smart IV can connect up to 128 devices (including indoor units, ERV, DI/DOs, DOKITs, AWHPs, AHUs) or 64 devices (including indoor units, ERV, DI/DOs, DOKITs, AWHPs and AHUs) and 9 I/O Modules.

The following shows an example of connecting AC Smart IV with such devices.

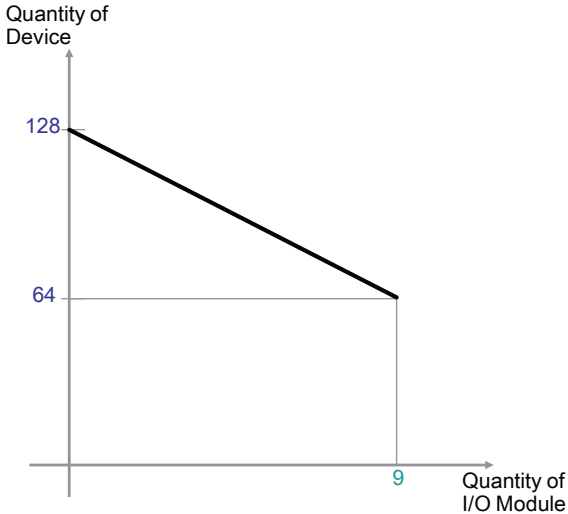

Quantity of I/O Module	Quantity of Device
0	128
1	121
2	114
3	107
4	100
5	93
6	86
7	79
8	72
9	64

\* Devices : Indoor units, ERV, DI/DOs, DOKITs, AWHPs, AHUs

AC Smart IV connects with PI485 and uses RS485 to communicate and exchange information. Allocate unique addresses to those devices (internal units, ERV, DI/DOs, DOKITs, AWHPs, AHUs, I/O Modules) that will connect with AC Smart IV. The addresses are hexadecimal numbers that can be chosen from 00 to FF.

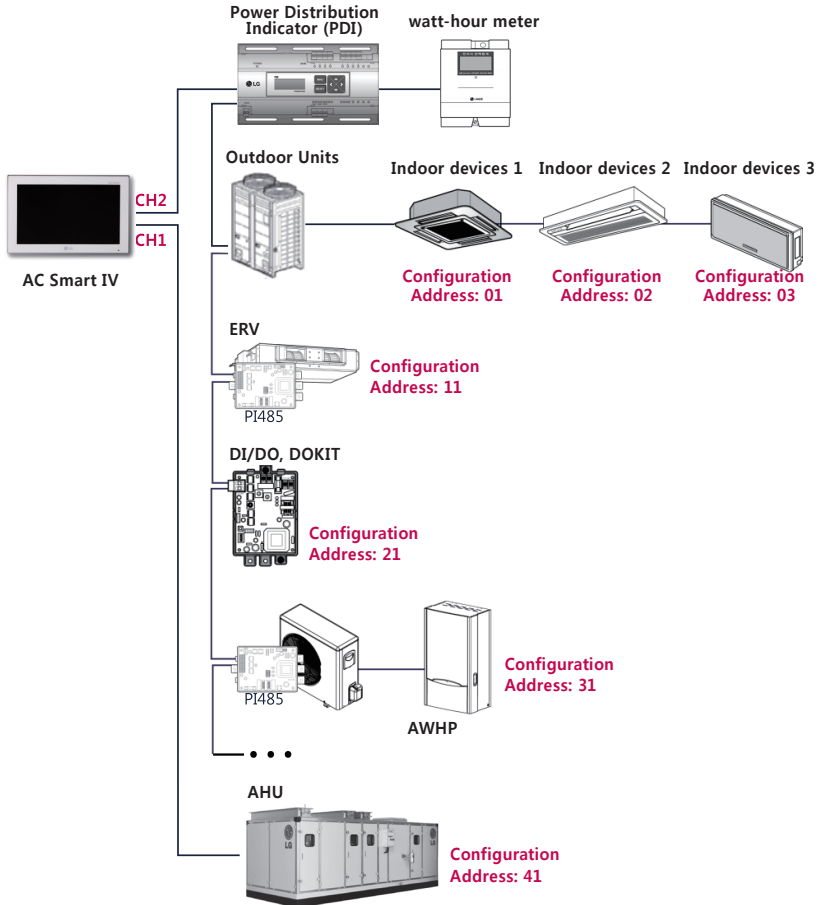

## NOTES

- The maximum allowed communication distance guaranteed by LG Electronics is 1 000 m. It means that the distance between AC Smart IV and the farthest device should not exceed 1 000 m. It is recommended that the communication cable use 0.75 mm square or more.
- For indoor units, ERV, DI/DOs, DOKITs, AHPs, AHUs and I/O Modules, you cannot allocate identical addresses among devices of the same type. Allocate different addresses for devices of the same type. (the indoor unit and DOKIT cannot use the same address.)
- Each device which can be used with PDI must be set to a unique address when connected with PDI. For further information about the devices can be used with PDI, please refer to the PDI manual.
- Connecting I/O Module, address setting should not be 00 because 00 is used to Broadcast in MODBUS communication.

AC Smart IV's RS485 connection

An AC Smart IV can have up to 128 indoor units. If there are many outdoor units to be connected, connect them to a bus. If not, AC Smart IV may malfunction.

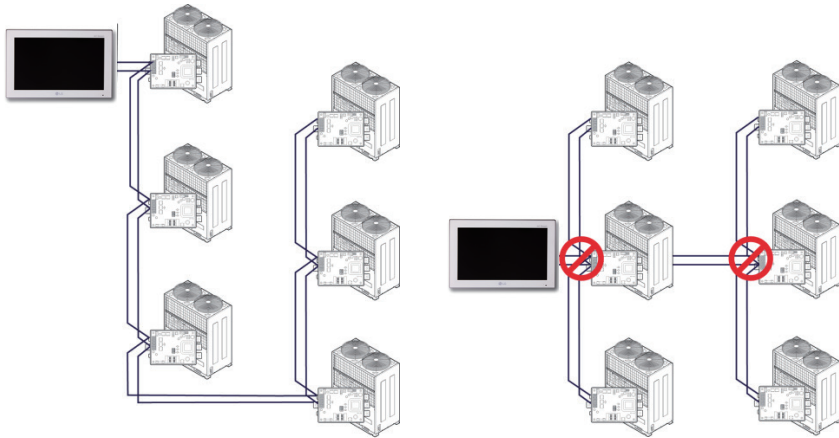

<Good example: RS485 BUS form connection>

<Bad example: RS485 STAR form connection>

**! NOTES**

Maximum node numbers which can be connected to RS485 communication line.

- **Multi V**  
Maximum of 16 nodes can be connected to 1 RS485 line.
- **Multi/Single**  
Maximum of 32 nodes can be connected to 1 RS485 line.
- **ERV**  
Maximum of 32 nodes can be connected to 1 RS485 line.

**Connect AC Smart IV**

You can install AC Smart IV and its cables as follows.

1. Choose a space for AC Smart IV.
  - Prior to securing AC Smart IV, check if the space is suitable for installing AC Smart IV, an RS485 cable, power cord, and an Ethernet cable.
2. Secure the back panel of AC Smart IV to the wall under which the RS485 cable is located.

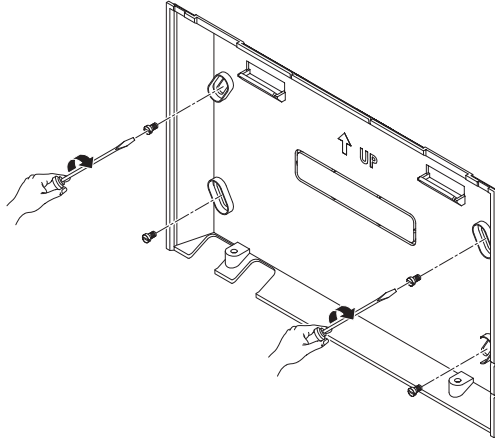

3. Extend the RS485 cable through the top opening of the back panel.

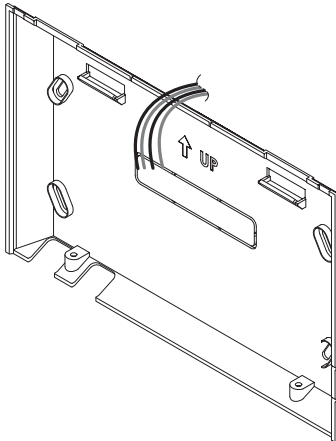

4. Connect the RS485 cable, which is located behind the AC Smart IV, to the RS485 terminal.

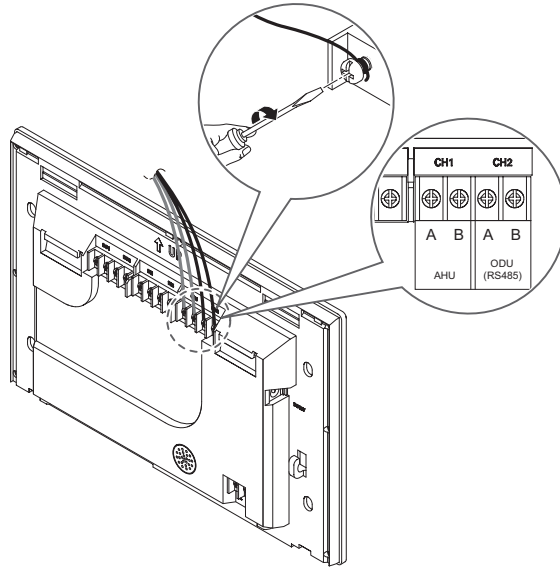

**CAUTION**

The RS485 cable is polarity sensitive, be careful about keeping polarity when connecting the cables.

5. To use the network functions (email transmission and web control) provided by AC Smart IV, connect an Ethernet cable to the LAN port on the back of AC Smart IV.

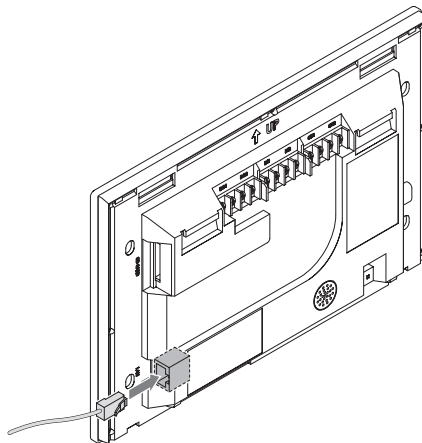

**6.** Connect the power.

- For global models
  - On the back of AC Smart IV, connect the power adapter to the power port.

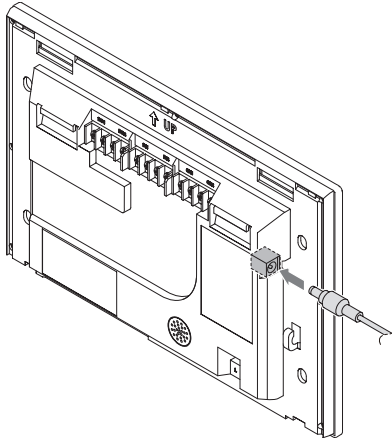

The adaptor is not provided with the AC Smart IV package sold in the U.S.

**NOTES**

You can hang the power cord on the power cord hanger located below the power port.

- For US models
  - At the bottom of AC Smart IV, connect the power cord to the power port.

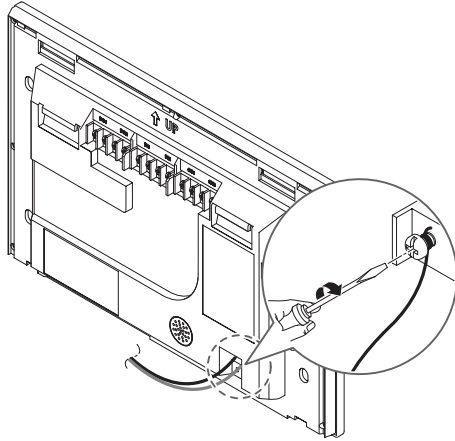

## NOTES

In some countries, except for the U.S., you can connect the DC 12 V power to the AC Smart IV by using the provided adapter. If necessary, connect the 24 V~ power to the AC Smart IV.

7. After attaching the hook on the top of the main body to the top of the rear panel installed on the wall, please push the top of the main body unit forward for firm attachment.

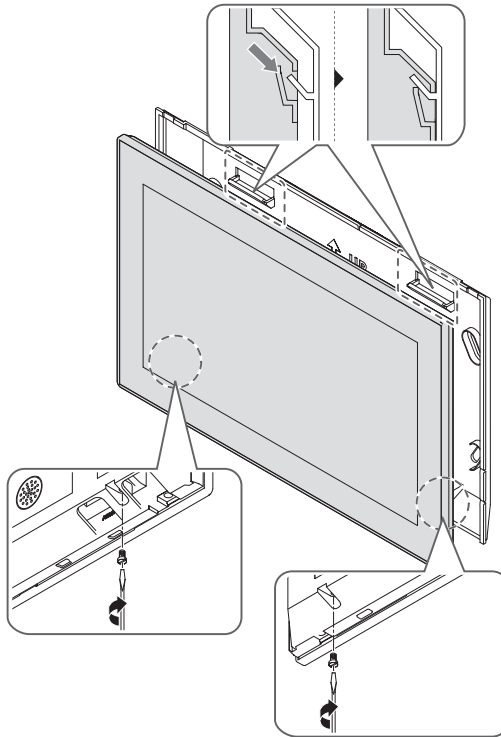
**CAUTION**

Secure two points on the bottom of the unit to prevent from falling.

**NOTES****Product removal**

After removing 2 screws from the bottom of the body, slightly pull the body using the flatblade screwdriver and lift up the body to remove the product.

8. Connect the power cord of the power adapter to the power plug.

## Configure Remote Shutdown Feature

The AC smart IV is equipped with an emergency stop function which terminates operation of all connected devices (indoor unit, ERV, DOKIT, AWHP and AHU) in the case of an emergency situation inside the building. Once the sensor has detected an emergency situation and then transmits an On signal to Port DI 1 of the AC Smart IV, all devices connected to the AC Smart IV stop their operation.

You can use the emergency stop function if you connect the sensor detecting external movements to Port DI 1 of the connected terminal, which works by electric contact without power, at the back of the AC Smart IV.

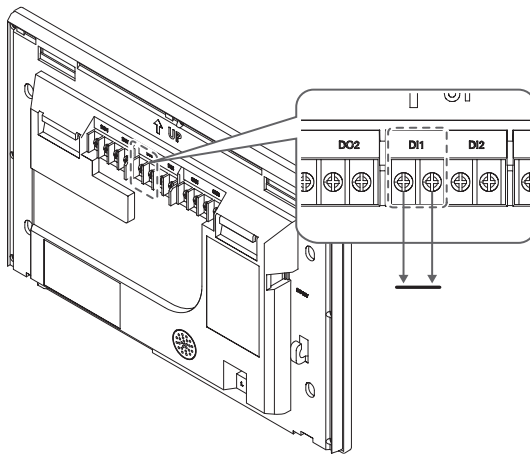

### CAUTION

Port DI 1 shall always be kept open unless in emergency.

## Information Input Method

ENGLISH

Touch the AC Smart IV information input box and a touch keyboard at the bottom of the panel will appear. Use the touch keyboard to input information.

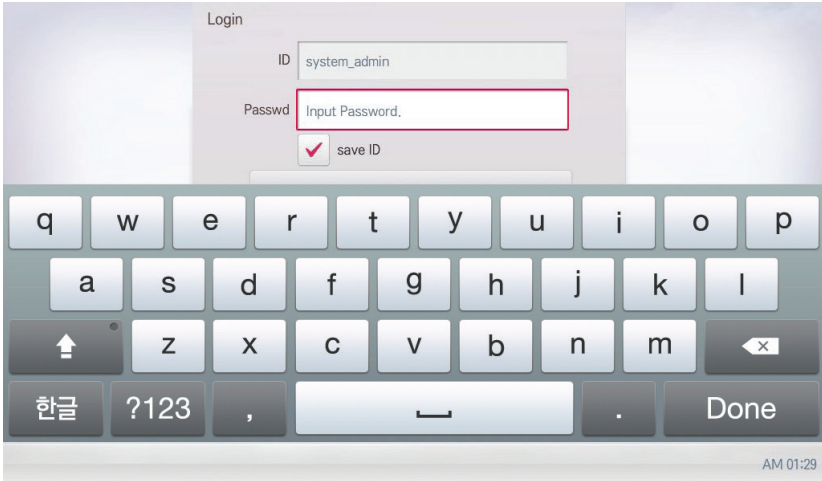

# STARTING

This section explains how to connect to the system and register devices to setup the environment (prior to using AC Smart IV).

## Turning on/off the screen

The following explains how to turn on or off the AC Smart IV screen.

### Turning on the screen

You can turn on the screen as follows.

1. Press the power button on the bottom of the unit.
  - The screen turns on.

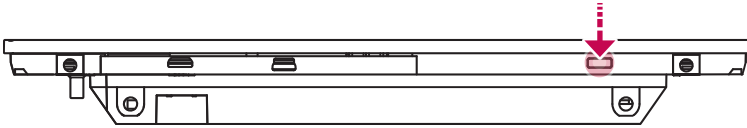

### Turning off the screen

You can turn off the screen as follows.

1. Briefly press the power button on the bottom of the unit.
  - The screen turns off.

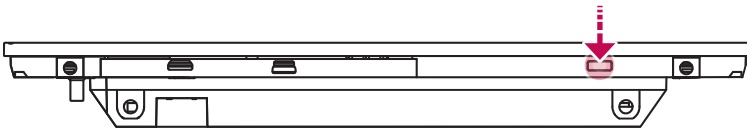

### NOTES

If you are not going to use AC Smart IV for a long time, it is recommended that the screen be turned off.

## Rebooting

You can reboot the device as follows.

1. Press the power button on the bottom of the unit for 10 or more seconds.
  - The device reboots.

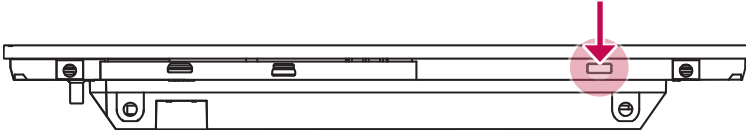

## Login and logout

The following explains how to log in and out of AC Smart IV.

AC Smart IV can control and monitor equipment by touch screen or Web access. If you enter the IP address of the AC Smart IV in the address bar of the Internet without the installation of another program, the central control program AC Smart IV, Web server will execute automatically, to use the functionality of the various content.

The manual will explain AC Smart IV standard equipment.



### NOTES

- You will need the Adobe Flash Player installed for the Web control access. (Recommended specification: Adobe Flash Player 11)
- The special character (^), (') and (,) are not available.

# Troubleshoot

## Control Codes

AC Smart IV may display the following control codes during usage

Control Code	Description
S	Displayed when the device status has changed due to the control
M	Displayed when the system settings have changed
E	Displayed when there is an error

## Error Codes

The following error codes may appear while using AC Smart IV.

### Indoor Device, ERV or ERV DX, AWHP(Hydro kit), AHU error

Error Code	Indoor Device	ERV or ERV DX	AWHP(Hydro kit)	AHU
0	No error	No error	No error	
1	Indoor sensor air) open/short	Air intake sensor malfunction	Indoor air thermometer malfunction	
2	Indoor sensor (intake pipe) open/short	Refrigerant intake thermometer malfunction	Refrigerant intake thermometer malfunction	Communication PCB indoor sensor (intake pipe) error
3	Remote control malfunction	Remote control malfunction	Remote control malfunction	The remote control is not functioning for 3 minutes or longer.
4	Drain pump malfunction	Drain pump malfunction		Communication PCB is not functioning for 3 minutes or or longer.
5	Communication error (indoor ↔ outdoor)	Communication error (indoor ↔ outdoor)	Communication error (indoor ↔ outdoor)	Communication error (communication PCB ↔ outdoor)
6	Indoor sensor (outtake pipe) open/short	Refrigerant outtake thermometer malfunction	Refrigerant outtake thermometer malfunction	Communication PCB indoor sensor (outtake pipe) error
7	Atypical operation	Atypical operation	Atypical operation	

Error Code	Indoor Device	ERV or ERV DX	AWHP(Hydro kit)	AHU
8			Hot water thermometer malfunction	Operate smoke control through smoke detection.
9	EEPROM ERROR (indoor unit)	EEPROM ERROR (indoor unit)	EEPROM ERROR (indoor unit)	
10	Indoor fan LOCK (operation error)	Indoor fan Lock (operation error)		
11			HHU/boiler communication error (HHU)	
12	Indoor mid-pipe sensor error		Boiler error (HHU)	
13	Heater terminal block sensor (A-PAC)		Solar heat temperature sensor error	Temperature (ERV, air supply, external air, Mix) is outside acceptable range.
14			Indoor unit flow switch operation error	Humidity (ERV, air supply, external air) is outside acceptable range
15	O-ROTOR (BLDC FAN driver) communication error		Water pipe overheating	CO <sub>2</sub> value is within acceptable range
16			Simultaneous AWHP temperature sensor error	Pressure (pressure change, static pressure) is outside acceptable range
17		ERV DX air out sensor	Inlet water temperature sensor error	Speed (ERV and air supply flow) is outside acceptable range.
18		ERV DX air return sensor	Outlet water temperature sensor error	
19		ERV DX Main PCB ← Sub PCB communication error	Elec/Heater outlet water temperature sensor error	
20		ERV DX Main PCB → Sub PCB communication error	Elec/heater error	

## Outdoor Unit Errors

Error Code	Description
21	DC peak
22	Max ct (CT 2): Maximum current error
23	DC link voltage (low)
24	High voltage/heat plate SW
25	Under-voltage/over-voltage
26	DC comp position error
27	PSC fault error
28	DC link voltage (high)
29	Comp over-current
30	Surge in static speed #2 compressor discharge temperature
31	CT err (low current)
32	Inverter discharge temperature error (high)
33	Surge in static speed #1 compressor discharge temperature
34	Surge in high voltage
35	Drop in low voltage
36	Low compression ratio error
37	Compression ratio limit exceeded
39	Communication error (inverter ↔ PFC)
40	Inverter CT sensor open/short
41	Inverter discharge temperature sensor open/short
42	Low voltage sensor open/short
43	Heat exchanger temperature sensor (top)
44	Outdoor air temperature sensor open/short
45	Outdoor pipe (top) sensor open/short
46	Compressor suction temperature sensor open/short
47	Static speed #1 compressor discharge temperature sensor error
48	Heat exchanger temperature sensor (bottom) (SUPER3: Static speed #2 compressor discharge temperature sensor error)
49	Outdoor voltage sensor error (SUPER3: IPM temperature sensor error)
50	Missing phase of outdoor 3-phase power
51	Over-capacity error (indoor unit capacity limit exceeded)
52	Communication error (inverter board → main board)
53	Communication error (indoor device → outdoor unit)
54	RST reverse phase detection

Error Code	Description
55	Communication error (central to main controller)
56	Communication error (main to central controller)
57	Communication error (main board to inverter board)
58	Incorrect connection of tax product (tax-exempt indoor unit to taxed outdoor unit)
59	Mixed installation of slave outdoor unit
60	PCB EEPROM error (MULTI V: inverter PCB EEPROM error)
61	Inverter discharge temperature error (high)
62	Heatsink error (high)
63	Outdoor pipe temperature error (low)
65	Heatsink Th error (open/short)
66	Bad connection/piping (incorrect connection of wire, pipe, LEV, etc.)
67	Outdoor fan lock error (with BLDC)
68	Static speed comp CT open (add MPS)
69	Static #1 CT sensor error
70	Static #2 CT sensor error
71	Input CT sensor error
72	Communication error (louver ↔ fan)
73	Input instant over-current (peak)
74	Inverter PCB phase unbalance
75	Fan CT sensor error
76	Fan DC link over-voltage error
77	Fan over-current error
78	Fan hall sensor error
79	Fan start failure error
80	Louver motor over-current
81	Louver limit SW error
82	A-cycle low pressure error
83	B-cycle low pressure error
84	A-cycle high pressure error
85	B-cycle high pressure error
86	Main PCB EEPROM error
87	Fan PCB EEPROM error
88	PFC PCB EEPROM error
89	Detachable type distributor communication error

## MultiV 20 Hp, 30 Hp, 40 Hp, error

Error Code	Description
100	SLAVE1 static speed compressor 1 discharge temperature surge error
101	SLAVE1 static speed compressor 2 discharge temperature surge error
102	SLAVE2 static speed compressor 1 discharge temperature surge error
103	SLAVE2 static speed compressor 2 discharge temperature surge error
104	Communication error with outdoor unit (slave to master)
105	Fan board communication error (fan to outdoor unit)
106	Fan board (IPM fault)
107	Fan board (low voltage error)
108	Communication error (outdoor unit to fan)
109	SLAVE1 (high voltage SW error)
110	SLAVE1 (reverse phase error)
111	SLAVE1 (communication error: master to slave)
112	Master outdoor unit sensor (oil pipe temperature sensor error)
113	Master outdoor unit sensor (fluid pipe temperature sensor error)
114	Master outdoor unit sensor (overcooling inlet temperature sensor error)
115	Master outdoor unit sensor (overcooling outlet temperature sensor error)
116	SLAVE1 outdoor unit sensor (high voltage sensor error)
117	SLAVE1 outdoor unit sensor (low voltage sensor error)
118	SLAVE1 outdoor unit sensor (low voltage sensor error)
119	SLAVE1 outdoor unit sensor (oil pipe temperature sensor error)
120	SLAVE1 outdoor unit sensor (suction temperature sensor error)
121	SLAVE1 outdoor unit sensor (static speed compressor 1 discharge temperature error)
122	SLAVE1 outdoor unit sensor (static speed compressor 2 discharge temperature error)
123	SLAVE1 outdoor unit sensor (heat exchanger temperature sensor A error)
124	SLAVE1 outdoor unit sensor (heat exchanger temperature sensor B error)
125	SLAVE1 outdoor unit (fluid pipe temperature sensor error)
126	SLAVE1 outdoor unit (overcooling inlet temperature sensor error)
127	SLAVE1 outdoor unit (overcooling outlet temperature sensor error)
128	SLAVE2 outdoor unit sensor (high voltage sensor error)
129	SLAVE2 outdoor unit sensor (low voltage sensor error)
130	SLAVE2 outdoor unit sensor (air temperature sensor error)
131	SLAVE2 outdoor unit sensor (oil pipe temperature sensor error)
132	SLAVE2 outdoor unit sensor (suction temperature sensor error)

Error Code	Description
133	SLAVE2 outdoor unit sensor (static speed compressor 1 discharge temperature error)
134	SLAVE2 outdoor unit sensor (static speed compressor 2 discharge temperature error)
135	SLAVE2 outdoor unit sensor (heat exchanger temperature sensor A error)
136	SLAVE2 outdoor unit sensor (heat exchanger temperature sensor B error)
137	SLAVE2 outdoor unit (fluid pipe temperature sensor error)
138	SLAVE2 outdoor unit (overcooling inlet temperature sensor error)
139	SLAVE2 outdoor unit (overcooling outlet temperature sensor error)
140	Fluid pipe sensor error of heat recovery unit
141	Overcooling inlet sensor error of heat recovery unit
142	Overcooling outlet sensor error of heat recovery unit
143	Heat recovery unit communication error
144	Heat recovery unit reserve 1
145	Heat recovery unit reserve 2
146	Heat recovery unit reserve 3
147	Heat recovery unit reserve 4
148	Heat recovery unit reserve 5
176	SLAVE2 static speed 1 compressor over-current/under-current
177	SLAVE2 static speed 2 compressor over-current/under-current
178	SLAVE3 static speed 1 compressor over-current/under-current
179	SLAVE3 static speed 2 compressor over-current/under-current
180	Anti-Freeze (water-cooling)
181	Water temperature sensor error (water-cooling)
182	Sub Micom communication error
183	Oil supply failure
184	Inverter oil pipe temperature sensor error
185	Static #1 oil pipe temperature sensor error
186	Static #2 oil pipe temperature sensor error
193	Fan board heat plate temperature surge
194	Fan board heat plate temperature sensor error

## Super Errors

Error Code	Description
200	Fan board heat plate temperature sensor error
201	Fluid pipe sensor error (fluid pipe sensor of HR Unit1 open/short)
202	Overcooling inlet sensor error (overcooling inlet sensor of HR Unit1 open/short)
203	Overcooling outlet sensor error (overcooling outlet sensor of HR unit1 open/short)
204	Overcooling outlet sensor error (overcooling outlet sensor of HR unit1 open/short)
205	Fluid pipe sensor error (fluid pipe sensor of HR Unit2 open/short)
206	Overcooling inlet sensor error (overcooling inlet sensor of HR Unit2 open/short)
207	Overcooling outlet sensor error (overcooling outlet sensor of HR unit2 open/short)
208	Communication error (no outdoor unit signal for 3 min from HR unit2)
209	Fluid pipe sensor error (fluid pipe sensor of HR Unit3 open/short)
210	Overcooling inlet sensor error (overcooling inlet sensor of HR Unit3 open/short)
211	Overcooling outlet sensor error (overcooling outlet sensor of HR unit3 open/short)
212	Communication error (no outdoor unit signal for 3 min from HR unit3)
213	Fluid pipe sensor error (fluid pipe sensor of HR Unit4 open/short)
214	Overcooling inlet sensor error (overcooling inlet sensor of HR Unit4 open/short)
215	Overcooling outlet sensor error (overcooling outlet sensor of HR unit4 open/short)
216	Communication error (no outdoor unit signal for 3 min from HR unit4)
217	Fluid pipe sensor error (fluid pipe sensor of HR Unit5 open/short)
218	Overcooling inlet sensor error (overcooling inlet sensor of HR Unit5 open/short)
219	Overcooling outlet sensor error (overcooling outlet sensor of HR unit5 open/short)
220	Communication error (no outdoor unit signal for 3 min from HR unit5)
221	Fluid pipe sensor error (fluid pipe sensor of HR Unit6 open/short)
222	Overcooling inlet sensor error (overcooling inlet sensor of HR Unit6 open/short)
223	Overcooling outlet sensor error (overcooling outlet sensor of HR unit6 open/short)
224	Communication error (no outdoor unit signal for 3 min from HR unit6)
225	Fluid pipe sensor error (fluid pipe sensor of HR Unit7 open/short)
226	Overcooling inlet sensor error (overcooling inlet sensor of HR Unit7 open/short)
227	Overcooling outlet sensor error (overcooling outlet sensor of HR unit7 open/short)
228	Communication error (no outdoor unit signal for 3 min from HR unit7)
229	Fluid pipe sensor error (fluid pipe sensor of HR Unit8 open/short)
230	Overcooling inlet sensor error (overcooling inlet sensor of HR Unit 8 open/short)
231	Overcooling outlet sensor error (overcooling outlet sensor of HR unit8 open/short)
232	Communication error (no outdoor unit signal for 3 min from HR unit8)

Error Code	Description
233	Fluid pipe sensor error (fluid pipe sensor of HR Unit9 open/short)
234	Overcooling inlet sensor error (overcooling inlet sensor of HR Unit9 open/short)
235	Overcooling outlet sensor error (overcooling outlet sensor of HR unit9 open/short)
236	Communication error (no outdoor unit signal for 3 min from HR unit9)

## Central Controller Errors

Error Code	Description
240	Communication error (PC central controller ↔ I-GW)
242	Communication error (central controller ↔ indoor unit)
246	Data in time out error from central controller
247	Communication error (ACM Client ↔ ACM Server)
248	Communication error (ACP Client ↔ ACP Server)
250	Checksum error
251	Communication error (AC Smart to 128-room expansion kit)

## Pre-Tech Support Checklist

If the product malfunctions, please check the following before calling the service center.

Symptom	Check	Actions
The alarm sound does not stop.	<ul style="list-style-type: none"> <li>Is the demand controller working normally?</li> <li>Is the LAN cable connected to the product?</li> </ul>	<ul style="list-style-type: none"> <li>Check if the demand controller is normal.</li> <li>Check if the LAN cable is connected correctly to the device.</li> </ul>
All products continue to turn off.	Is DI1 CH short-circuited?	Check if DI1 CH is open or short circuited. (DI1 CH should be always open except when an emergency occurs.)
The product was reset at midnight.	The product is automatically reset every morning at 02:05 am.	
The device is not controlled.	Is the device you want to control not locked?	Check if the lock is on and if so, disable the lock.
The device icon has an error mark.	Is the device with errors connected correctly?	If devices are not correctly connected, the error sign is displayed. Check the connection status of the devices.

## OPEN SOURCE SOFTWARE NOTICE

To obtain the source code under GPL, LGPL, MPL and other open source licenses, that is contained in this product, please visit <http://opensource.lge.com>.

In addition to the source code, all referred license terms, warranty disclaimers and copyright notices are available for download.

LG Electronics will also provide open source code to you on CD-ROM for a charge covering the cost of performing such distribution (such as the cost of media, shipping and handling) upon email request to [opensource@lge.com](mailto:opensource@lge.com). This offer is valid for three (3) years from the date on which you purchased the product.

