



INSTALLATION MANUAL

AIR CONDITIONER

VRF FOR INDOOR
INSTALLATION

Please read this installation manual completely before installing the product.
Installation work must be performed in accordance with the national wiring standards
by authorized personnel only.

Please retain this installation manual for future reference after reading it thoroughly.

MULTI V™

Original instruction



MFL70344401
Rev.07_110325

Copyright © 2018 - 2025 LG Electronics Inc. All Rights Reserved.

www.lg.com

ENGLISH

ITALIANO

ESPAÑOL

FRANÇAIS

DEUTSCH

ČEŠTINA

ΕΛΛΗΝΙΚΑ

NETERLANDS

POLSKI

LIMBA ROMÂNĂ

TIPS FOR SAVING ENERGY

Here are some tips that will help you minimize the power consumption when you use the air conditioner. You can use your air conditioner more efficiently by referring to the instructions below:

- Do not cool excessively indoors. This may be harmful for your health and may consume more electricity.
- Block sunlight with blinds or curtains while you are operating the air conditioner.
- Keep doors or windows closed tightly while you are operating the air conditioner.
- Adjust the direction of the air flow vertically or horizontally to circulate indoor air.
- Speed up the fan to cool or warm indoor air quickly, in a short period of time.
- Open windows regularly for ventilation as the indoor air quality may deteriorate if the air conditioner is used for many hours.
- Clean the air filter once every 2 weeks. Dust and impurities collected in the air filter may block the air flow or weaken the cooling / dehumidifying functions.

For your records

Staple your receipt to this page in case you need it to prove the date of purchase or for warranty purposes. Write the model number and the serial number here:

Model number : _____

Serial number : _____

You can find them on a label on the side of each unit.

Dealer's name : _____

Date of purchase : _____

IMPORTANT SAFETY INSTRUCTIONS

READ ALL INSTRUCTIONS BEFORE USING THE APPLIANCE.

Always comply with the following precautions to avoid dangerous situations and ensure peak performance of your product.

⚠ WARNING

It can result in serious injury or death when the directions are ignored.

⚠ CAUTION

It can result in minor injury or product damage when the directions are ignored.

⚠ WARNING

- Installation or repairs made by unqualified persons can result in hazards to you and others.
- The information contained in the manual is intended for use by a qualified service technician familiar with safety procedures and equipped with the proper tools and test instruments.
- Failure to carefully read and follow all instructions in this manual can result in equipment malfunction, property damage, personal injury and/or death.

Installation

- Use the outdoor air suction hole with the net installed to ensure that birds could not come in. Remove estrange things like the bird's nest. Otherwise, it may cause scarcity of indoor oxygen.
- Install the air intake where polluted air can not be directly sucked in. It may cause various accident, including suffocation, due to the suction of harmful gasses(CO, etc.)
- Have all electric work done by a licensed electrician according to "Electric Facility Engineering Standard" and "Interior Wire Regulations" and the instructions given in this manual and always use a special circuit.
 - If the power source capacity is inadequate or electric work is performed improperly, electric shock or fire may result.

- Ask the dealer or an authorized technician to install the air conditioner.
 - Improper installation by the user may result in water leakage, electric shock, or fire.
 - Always ground the product.
 - There is risk of fire or electric shock.
 - Always install a dedicated circuit and breaker.
 - Improper wiring or installation may cause fire or electric shock.
 - For re-installation of the installed product, always contact a dealer or an Authorized Service Center.
 - There is risk of fire, electric shock, explosion, or injury.
 - Do not install, remove, or re-install the unit by yourself (customer).
 - There is risk of fire, electric shock, explosion, or injury.
 - Do not store or use flammable gas or combustibles near the air conditioner.
 - There is risk of fire or failure of product.
 - Use the correctly rated breaker or fuse.
 - There is risk of fire or electric shock.
 - Prepare for strong wind or earthquake and install the unit at the specified place.
 - Improper installation may cause the unit to topple and result in injury.
 - Do not install the product on a defective installation stand.
 - It may cause injury, accident, or damage to the product.
 - Use a vacuum pump or Inert(nitrogen) gas when doing leakage test or air purge. Do not compress air or Oxygen and do not use Flammable gases. Otherwise, it may cause fire or explosion.
 - There is the risk of death, injury, fire or explosion.
 - When installing and moving the air conditioner to another site, do not charge it with a different refrigerant from the refrigerant specified on the unit.
 - If a different refrigerant or air is mixed with the original refrigerant, the refrigerant cycle may malfunction and the unit may be damaged.
 - Do not reconstruct to change the settings of the protection devices.
 - If the pressure switch, thermal switch, or other protection device is shorted and operated forcibly, or parts other than those specified by LGÉ are used, fire or explosion may result.
 - Ventilate before operating air conditioner when gas leaked out.
 - It may cause explosion, fire, and burn.
 - Securely install the cover of control box and the panel.
 - If the cover and panel are not installed securely, dust or water may enter the MULTI V M and fire or electric shock may result.
 - If the air conditioner is installed in a small room, measures must be taken to prevent the refrigerant concentration from exceeding the safety limit when the refrigerant leaks.
 - Consult the dealer regarding the appropriate measures to prevent the safety limit from being exceeded. Should the refrigerant leak and cause the safety limit to be exceeded, hazards due to lack of oxygen in the room could result.
 - Means for disconnection must be incorporated in the fixed wiring in accordance with the wiring rules
 - If the supply cord is damaged, it must be replaced by the manufacturer, its service agent or similarly qualified persons in order to avoid a hazard.
 - This equipment shall be provided with a supply conductor complying with the national regulation.
- Operation**
- Do not damage or use an unspecified power cord.
 - There is risk of fire, electric shock, explosion, or injury.
 - Use a dedicated outlet for this appliance.
 - There is risk of fire or electrical shock.
 - Be cautious that water could not enter the product.
 - There is risk of fire, electric shock, or product damage.

- Do not touch the power switch with wet hands.
 - There is risk of fire, electric shock, explosion, or injury.
- When the product is soaked (flooded or submerged), contact an Authorized Service Center.
 - There is risk of fire or electric shock.
- Be cautious not to touch the sharp edges when installing.
 - It may cause injury.
- Take care to ensure that nobody could step on or fall onto the MULTI V M.
 - This could result in personal injury and product damage.
- Do not open the inlet grille of the product during operation. (Do not touch the electrostatic filter, if the unit is so equipped.)
 - There is risk of physical injury, electric shock, or product failure.
- This appliance is not intended for use by persons (including children) with reduced physical, sensory or mental capabilities or lack of experience and knowledge, unless they have been given supervision or instruction concerning use of the appliance by a person responsible for their safety. Children should be supervised to ensure that they do not play with the appliance.

CAUTION

Installation

- Always check for gas (refrigerant) leakage after installation or repair of product.
 - Low refrigerant levels may cause failure of product.
- Do not install the product where the noise or hot air from the MULTI V M could damage the neighborhoods.
 - It may cause a problem for your neighbors.
- Keep level even when installing the product.
 - To avoid vibration or water leakage.
- Do not install the unit where combustible gas may leak.
 - If the gas leaks and accumulates around the unit, an explosion may result.
- Use power cables of sufficient current carrying capacity and rating.
 - Cables that are too small may leak, generate heat, and cause a fire.

Operation

- Do not use the air conditioner in special environments.
 - Oil, steam, sulfuric smoke, etc. can significantly reduce the performance of the air conditioner or damage its parts.
- Do not block the inlet or outlet.
 - It may cause failure of appliance or accident.
- Make the connections securely so that the outside force of the cable may not be applied to the terminals.
 - Inadequate connection and fastening may generate heat and cause a fire.
- Be sure the installation area does not deteriorate with age.
 - If the base collapses, the air conditioner could fall with it, causing property damage, product failure, or personal injury.

- Install and insulate the drain hose to ensure that water is drained away properly based on the installation manual.
 - A bad connection may cause water leakage.
- Be very careful about product transportation.
 - Only one person should not carry the product if it weighs more than 20 kg.
 - Some products use PP bands for packaging. Do not use any PP bands for a means of transportation. It is dangerous.
 - Do not touch the heat exchanger fins. Doing so may cut your fingers.
 - When transporting the MULTI V M, suspending it at the specified positions on the unit base. Also support the MULTI V M at four points so that it cannot slip sideways.
- Safely dispose of the packing materials.
 - Packing materials, such as nails and other metal or wooden parts, may cause stabs or other injuries.
 - Tear apart and throw away plastic packaging bags so that children may not play with them. If children play with a plastic bag which was not torn apart, they face the risk of suffocation.
- Turn on the power at least 6 hours before starting operation.
 - Starting operation immediately after turning on the main power switch can result in severe damage to internal parts. Keep the power switch turned on during the operational season.
- Do not touch any of the refrigerant piping during and after operation.
 - It can cause a burn or frostbite.
- Do not operate the air conditioner with the panels or guards removed.
 - Rotating, hot, or high-voltage parts can cause injuries.
- Do not directly turn off the main power switch after stopping operation.
 - Wait at least 5 minutes before turning off the main power switch. Otherwise it may result in water leakage or other problems.
- Auto-addressing should be done in condition of connecting the power of all indoor and outdoor units. Auto-addressing should also be done in case of changing the indoor unit PCB.
- Use a firm stool or ladder when cleaning or maintaining the air conditioner.
 - Be careful and avoid personal injury.
- Do not insert hands or other objects through the air inlet or outlet while the air conditioner is plugged in.
 - There are sharp and moving parts that could cause personal injury.
- This appliance can be used by children aged from 8 years and above and persons with reduced physical, sensory or mental capabilities or lack of experience and knowledge if they have been given supervision or instruction concerning use of the appliance in a safe way and understand the hazards involved. Children shall not play with the appliance. Cleaning and user maintenance shall not be made by children without supervision.

TABLE OF CONTENTS

2 TIPS FOR SAVING ENERGY

2 IMPORTANT SAFETY INSTRUCTIONS

7 INSTALLATION PROCESS

7 MULTI V M INFORMATION

7 ALTERNATIVE REFRIGERANT R410A

8 SELECT THE BEST LOCATION : COMPRESSOR MODULE

8 INSTALLATION SPACE : COMPRESSOR MODULE

8 SELECT THE BEST LOCATION : HEAT EXCHANGER MODULE

9 INSTALLATION GUIDE AT THE SEASIDE

9 INSTALLATION SPACE : HEAT EXCHANGER MODULE

9 CARRYING METHOD

10 INSTALLATION : COMPRESSOR MODULE

10 The location of the Anchor bolts

10 Foundation for Installation

11 INSTALLATION : HEAT EXCHANGER MODULE

12 Heat Exchanger Module Installation

13 Checking the Drainage

13 Indoor Unit Drain Piping

13 Method when insatalling the ducting

14 Method connect the refrigerant piping to the Heat Exchanger Module.

14 Preparation of Piping

14 Plumbing materials and storage methods

15 REFRIGERANT PIPING INSTALLATION

15 Precautions on Pipe connection / Valve operation

15 TO CONNECT THE REFRIGERANT PIPING TO THE COMPRESSOR MODULE

15 Preparation Work

16 Pipe Drawing Out

16 Selection of Refrigerant Piping

17 Refrigerant piping system

18 Refrigerant charging

19 Distribution Method

19 Branch pipe Fitting

20 Leak Test and Vacuum drying

21 Vacuum Mode

21 Thermal insulation of refrigerant piping

22 ELECTRICAL WIRING

23 Control box and connecting position of wiring

24 Communication and Power Cables

24 Wiring of main power supply and equipment capacity

24 Field Wiring

26 Checking the setting of outside units

27 Automatic Addressing

27 Group Number setting

28 Cool & Heat selector

28 Static pressure compensation mode

28 Night Low Noise Function

28 Setting the ODU address

29 Snow removal & rapid defrost

29 Target pressure adjusting

30 Self-Diagnosis Function

32 CAUTION FOR REFRIGERANT LEAK

32 Introduction

32 Checking procedure of limiting concentration

33 Model Designation

33 Airborne Noise Emission

INSTALLATION PROCESS

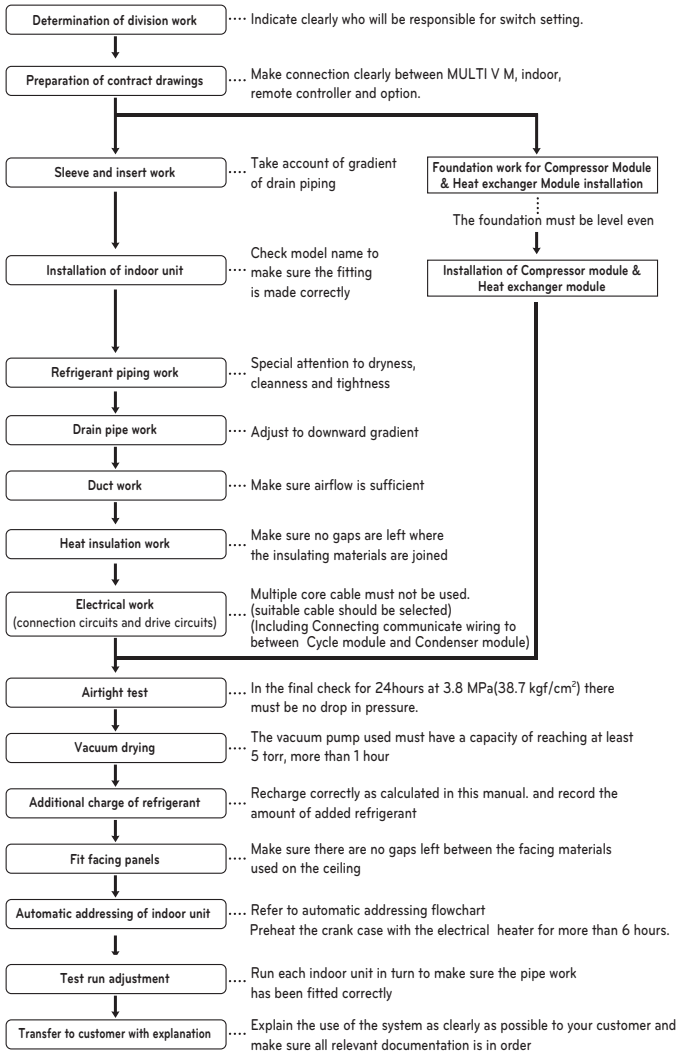

Compressor Module Power Supply : 380-415 V 3N~ 50 Hz

System(HP)			5
Model			ARUN050LMC0
Refrigerant Precharged Amount	kg		2
	lbs		4.4
Number of maximum connectable indoor units			10
Net weight	kg		69
	lbs		152
Dimensions (WxHxD)	mm		580 × 700 × 500
	inch		22.3 × 27.5 × 19.6
Piping Connections	Liquid Pipes	mm(inch)	Ø 9.52(3/8) to IDU
	Gas Pipes		Ø 15.88(5/8) to IDU
	Liquid Pipes		Ø 12.7(1/2) to Compressor Module
	Gas Pipes		Ø 19.05(3/4) to Compressor Module
MCA	A		12.1
MFA			20

Heat Exchanger Module Power Supply : 220-240 V~ 50 Hz

System(HP)			5
Model			ARUN050GME0
Refrigerant Precharged Amount	kg		-
	lbs		-
Number of maximum connectable indoor units			-
Net weight	kg		84
	lbs		185
Dimensions (WxHxD)	mm		1,562 × 460 × 688
	inch		61.5 × 18.1 × 27
Piping Connections	Liquid Pipes	mm(inch)	Ø 12.7(1/2) to Compressor Module
	Gas Pipes		Ø 19.05(3/4) to Compressor Module
MCA	A		7.5
MFA			15

MFA : Maximum Fuse Amperes(A)

MCA : Minimum Circuit Amperes(A)

CAUTION

- The above list indicates the order in which the individual work operations are normally carried out but this order may be varied where local conditions warrants such change.
- The thickness of the piping should comply with the relevant local and national regulations for the designed pressure 3.8MPa.
- Since R410A is a mixed refrigerant, the required additional refrigerant must be charged in its liquid state.(If the refrigerant is charged in its gaseous state, its composition changes and the system will not work properly.)

MULTI V M INFORMATION

CAUTION

- Ratio of the connectable Indoor Units to the MULTI V M : Within 50 ~ 130%
- Ratio of running Indoor Units to the MULTI V M: Within 10 ~ 100%
- A combination operation over 100% cause to reduce each indoor unit capacity.

ALTERNATIVE REFRIGERANT R410A

The refrigerant R410A has the property of higher operating pressure in comparison with R22.

Therefore, all materials have the characteristics of higher resisting pressure than R22 ones and this characteristic should be also considered during the installation.

R410A is an azeotrope of R32 and R125 mixed at 50:50, so the ozone depletion potential (ODP) of R410A is 0.

CAUTION

- The wall thickness of the piping should comply with the relevant local and national regulations for the designed pressure 3.8MPa
- Since R410A is a mixed refrigerant, the required additional refrigerant must be charged in its liquid state. If the refrigerant is charged in its gaseous state, its composition changes and the system will not work properly.
- Do not place the refrigerant container under the direct rays of the sun to prevent it from exploding.
- For high-pressure refrigerant, any unapproved pipe must not be used.
- Do not heat pipes more than necessary to prevent them from softening.
- Be careful not to install wrongly to minimize economic loss because it is expensive in comparison with R22.

SELECT THE BEST LOCATION : COMPRESSOR MODULE

It must be installed indoors.

Ambient design temperature of compressor module and Heat exchange module is 5~35°C (26°C WB)

Select space for installing compressor module, which will meet the following conditions:

- No direct thermal radiation from other heat sources.
- Do not installation where sensitive place the noise
- No exposition to strong wind
- With strength which bears weight of unit
- Note that drain flows out of unit when heating
- With space for air passage and service work shown next
- Because of the possibility of fire, do not install unit to the space where generation, inflow, stagnation, and leakage of combustible gas is expected.
- Avoid unit installation in a place where acidic solution and spray (sulfur) are often used.
- Do not use unit under any special environment where oil, steam and sulfuric gas exist.
- It is recommended to fence round the compressor module in order to prevent any person or animal from accessing the compressor module.

Select installation location considering following conditions to avoid bad condition when additionally performing defrost operation.

- Install the MULTI V M at a place well ventilated and having a lot of sunshine in case of installing the product at a place with a high humidity in winter (near beach, coast, lake, etc). (Ex) Rooftop where sunshine always shines.
- Performance of heating will be reduced and preheat time of the indoor unit may be lengthened in case of installing the Compressor Module in winter at following location:
 - Shade position with a narrow space
 - Location with much moisture in neighboring floor.
 - Location with much humidity around.
 - Location where ventilation is good. It is recommended to install the MULTI V M at a place with a lot of sunshine as possible as.
 - Location where water gathers since the floor is not even.

⚠ WARNING

Fix the Compressor Module firmly with anchor bolt or it may fall and hurt people. (refer to 'Foundation for installation')

INSTALLATION SPACE : COMPRESSOR MODULE

- The following values are the least space for installation. If any service area is needed for service according to field circumstance, obtain enough service space.
- The unit of values is mm.

Installation Space for Compressor Module

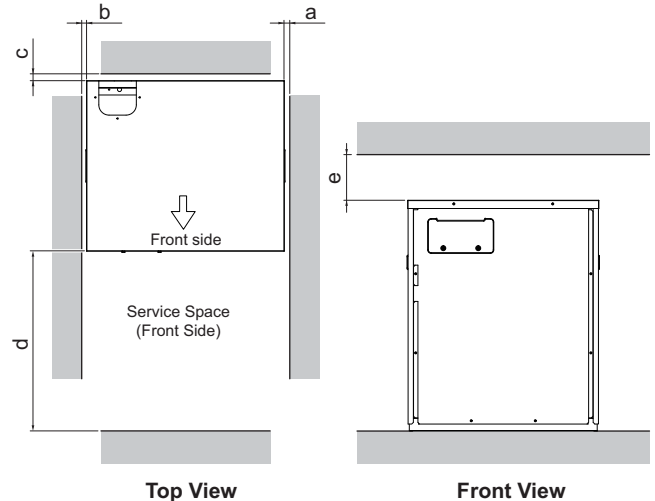

Category	Mark	Description	Installation Space [mm]
Compressor Module	a	Right	10 or more
	b	Left	10 or more
	c	Rear	10 or more
	d	Front	500 or more
	e	Top	200 or more

SELECT THE BEST LOCATION : HEAT EXCHANGER MODULE

It must be installed indoors.

Ambient design temperature of compressor module and Heat exchange module is 5~35°C (26°C WB)

The heat exchanger module has the same installation site requirements as the compressor module, and few additional ones. Install the air conditioner in the location that satisfies the following conditions.

- The place shall easily bear a load exceeding four times the Heat Exchanger Module weight.
- The place shall be able to inspect the Heat Exchanger Module as the figure.
- The place where the Heat Exchanger Module shall be leveled.
- The place shall allow easy water drainage. (Suitable dimension "H" is necessary to get a slope to drain as figure.)
- The place shall easily connect with the Compressor Module.
- The place where the Heat Exchanger Module is not affected by an electrical noise.
- There should not be any heat source or steam near the unit.

⚠ WARNING

Fix the Heat Exchanger Module firmly with anchor bolt or it may fall and hurt people. (refer to 'Foundation for installation')

INSTALLATION GUIDE AT THE SEASIDE

CAUTION

- Air conditioners should not be installed in areas where corrosive gases, such as acid or alkaline gas, are produced.
- Do not install the product where it could be exposed to sea wind (salty wind) directly. It can result corrosion on the product. Corrosion, particularly on the condenser and evaporator fins, could cause product malfunction or inefficient performance.
- If Heat Exchanger Module is installed close to the seaside, it should avoid direct exposure to the sea wind. Otherwise it needs additional anticorrosion treatment on the heat exchanger.
- Compressor minstalled odule and Heat Exchanger Module must be indoors.

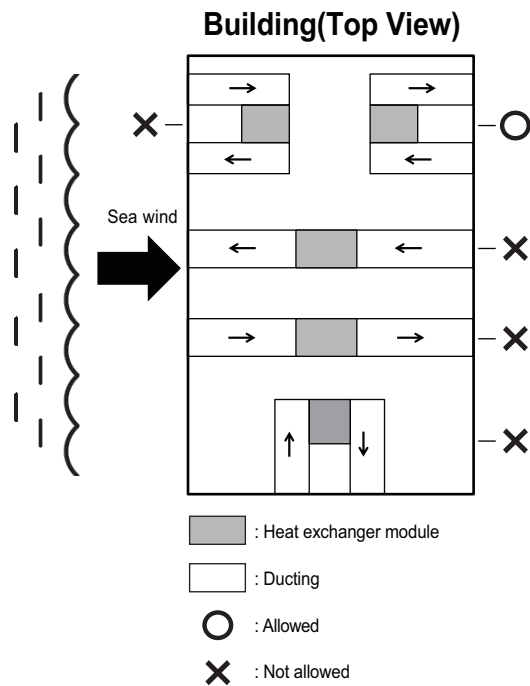

- It should be keep more than 70 cm of space between MULTI V M and the windbreak for easy air flow.

Select a well-drained place.

- Periodic (more than once/year) cleaning of the dust or salt particles stuck on the heat exchanger by using water

INSTALLATION SPACE : HEAT EXCHANGER MODULE

- The following values are the least space for installation. If any service area is needed for service according to field circumstance, obtain enough service space.
- The unit of values is mm.

Installation Space for Heat Exchanger Module

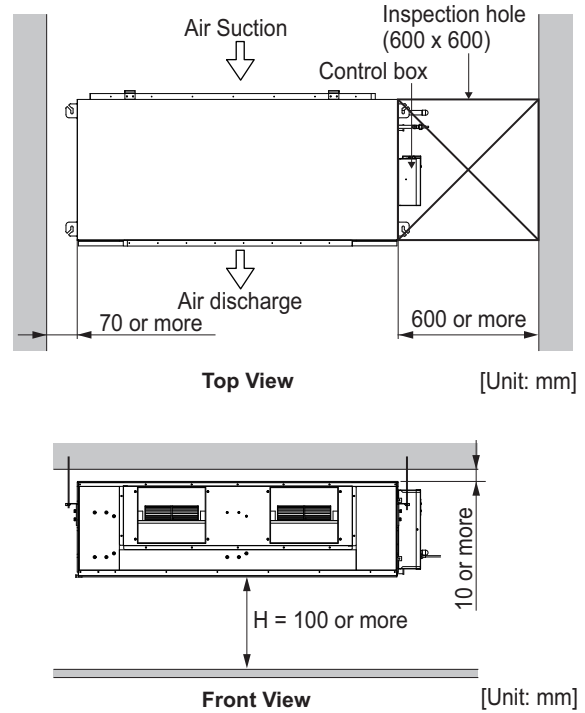

CARRYING METHOD

- Please transport the product referring to the figure.
- Use only accessories and parts which are of the designated specification when installing.

Compressor Module

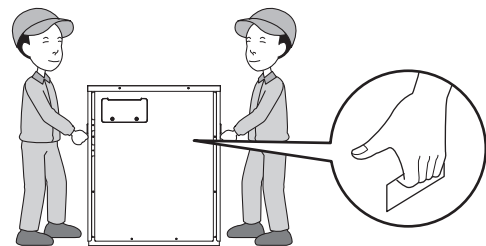

Heat Exchanger Module

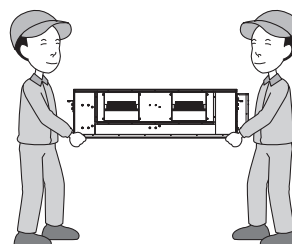

CAUTION

Be very careful while carrying the product.

- Do not have only one person carry product if it is more than 20 kg.
- PP bands are used to pack some products. Do not use them as a mean for transportation because they are dangerous.
- Do not touch heat exchanger fins with your bare hands. Otherwise you may get a cut in your hands.
- Tear plastic packaging bag and scrap it so that children cannot play with it. Otherwise plastic packaging bag may suffocate children to death.
- Place extra cloth or boards in the locations where the casing comes in contact with the sling to prevent damage.

Installation Accessories (Compressor Module)

Name	Quantity	Shape
Gas piping accessory (to heat exchanger Module) (Ø19.05 mm)	1EA	
Liquid piping accessory (to heat exchanger module) (Ø12.7 mm)	1EA	
Gas piping accessory (to indoor units) (Ø15.88 mm)	1EA	
Liquid piping accessory (to indoor module) (Ø9.52 mm)	1EA	

Installation Accessories (Heat Exchanger Module)

Name	Quantity	Shape
Drain hose	1EA	
Clamp metal	2EA	
Washer for hanging bracket	8EA	
Clamp (Tie Wrap)	4EA	
Insulation for fitting	1SET	for gas pipe for liquid pipe

CAUTION

- Remove accessories packed in the compressor module and heat exchanger module before installation.

INSTALLATION : COMPRESSOR MODULE

- You can install the compressor module directly on the floor or on a structure. If you want to install on floor, you do not use anchor bolt.
- Install at places where it can endure the weight and vibration/noise of the compressor module.
- The compressor module supports at the bottom shall have width of at least 100mm under the Unit's legs before being fixed.
- The compressor module supports should have minimum height of 200mm.
- Anchor bolts must be inserted at least 75mm.

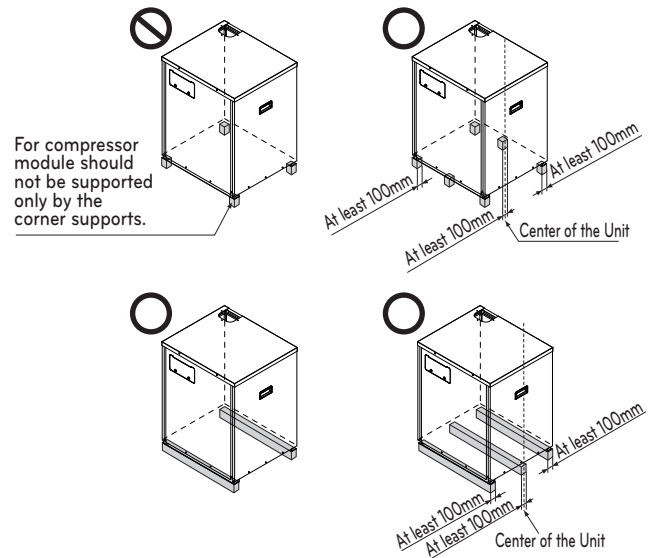
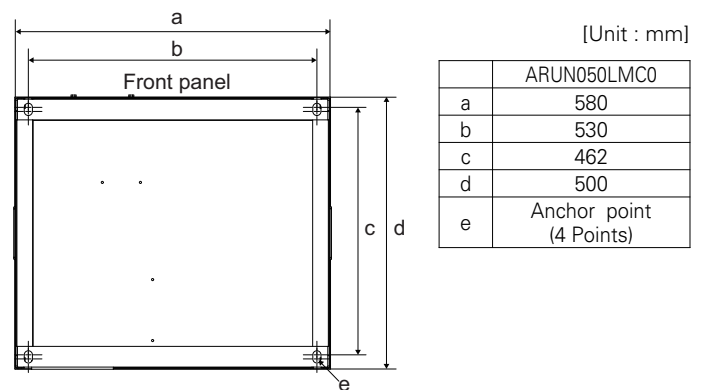
**The location of the Anchor bolts****Foundation for Installation**

- Fix the unit tightly with bolts as shown below so that unit will not fall down due to earthquake or gust.
- Use the H-beam support as a base support
- Noise and vibration may occur from the floor or wall since vibration is transferred through the installation part depending on installation status. Thus, use anti-vibration materials (cushion pad) fully (The base pad shall be more than 200mm).

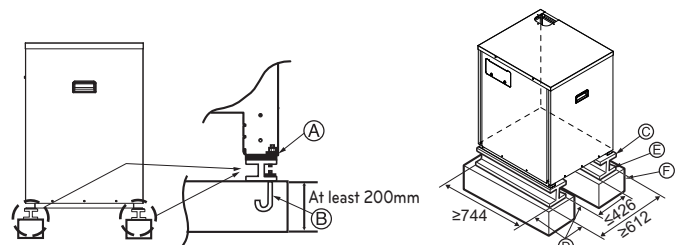

- Ⓐ The corner part must be fixed firmly. Otherwise, the support for the installation may be bent.
- Ⓑ Get and use M10 Anchor bolt.
- Ⓒ Put Cushion Pad between the Compressor Module and ground support for the vibration protection in wide area.
- Ⓓ Minimum foundation (mm)
- Fix the module used anchor bolts, nuts and washers(field supply) to the structuer.
- Ⓔ H-beam support
- Ⓕ Concrete support

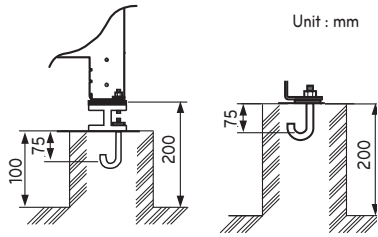

INSTALLATION : HEAT EXCHANGER MODULE

- Install the unit above the ceiling correctly.

CASE 1

Position of suspension Bolt

- Apply a joint-canvas between the module and duct to absorb unnecessary vibration.

(Unit:mm)

Dimension	A	B	C	D	E	F	G	H	I	J	K	L
Chassis												
B8	1680	1565	1160	330	460	580	700	1400	1635	390	445	15

B8 Chassis

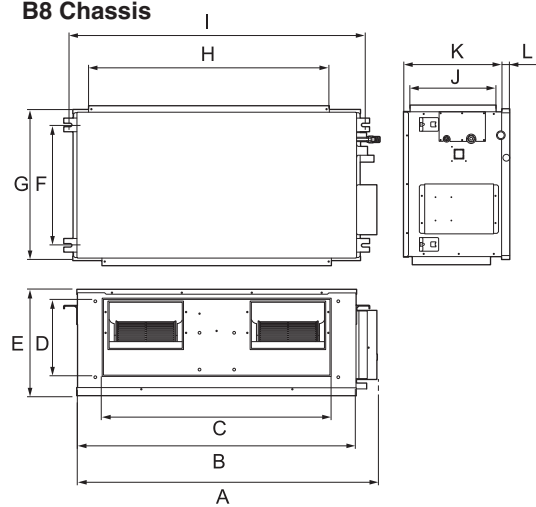

WARNING

- Install where it can sufficiently support the weight of the compressor module.
If the support strength is not enough, the compressor module may drop and hurt people.
- Install where the compressor module may not fall in strong wind or earthquake.
If there is a fault in the supporting conditions, the Compressor Module may fall and hurt people.
- Please take extra cautions on the supporting strength of the ground and the passages of the pipe and wiring, when making the ground support.

CAUTION

- In case of on the floor you should not have to fix the compressor module with anchor bolts.
- In case of on the structure you can fix the Compressor module securely use anchor bolts, nuts and washers to the structure.
The foundation must be larger than the image
- If noise / vibration occurs, install rubber pad under the product
- Be sure to remove the Pallet(Wood Support) of the bottom side of the compressor module before welding.
Not removing Pallet(Wood Support) causes hazard of fire during welding.
- When vibration is transmitted to the building, use a vibration proof rubber (field supply).

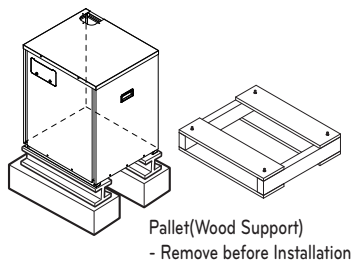

CASE 2

- Install the module leaning to a drainage hole side as a figure for easy water drainage.

Position of console Bolt

- A place where the module will be leveled and that can support the weight of the unit.
- A place where the module can withstand its vibration.
- A place where service can be easily performed.

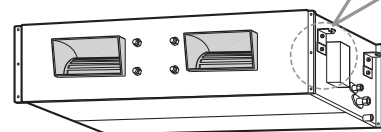
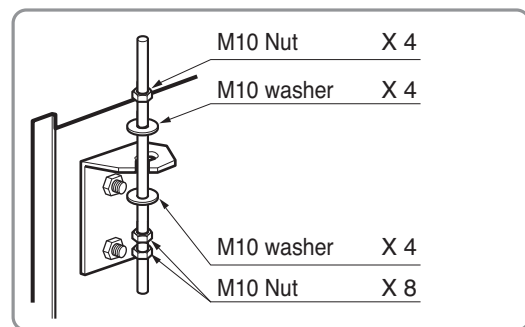

NOTE

- Thoroughly study the following installation locations:
1. In such places as restaurants and kitchens, considerable amount of oil steam and flour adhere to the fan, the fin of the heat exchanger, resulting in heat exchange reduction, spraying, dispersing of water drops, etc. In these cases, take the following actions:
 - Make sure that the ventilation fan for smoke-collecting hood on a cooking table has sufficient capacity so that it draws oily steam which should not flow into the suction of the air conditioner.
 - Make enough distance from a cooking room to install the air conditioner in such a place where it may not suck in oil steam.
 2. Avoid installing air conditioner in such circumstances where cutting oil mist or iron powder is in suspension in factories, etc.
 3. Avoid places where inflammable gas is generated, flows in, is stored or vented.
 4. Avoid places where sulfurous acid gas or corrosive gas is generated.
 5. Avoid places near high frequency generators.

Insulation, others : Insulate the joint and tubes completely.

Thermal insulation : All thermal insulation must comply with local requirement. See the Thermal insulation of refrigerant piping section for more information.

Heat Exchanger Module

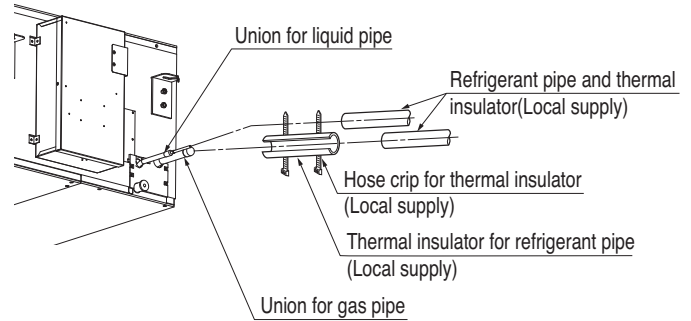

Heat Exchanger Module Installation

- Select and mark the position for fixing bolts.
- Drill the hole for set anchor on the face of ceiling.

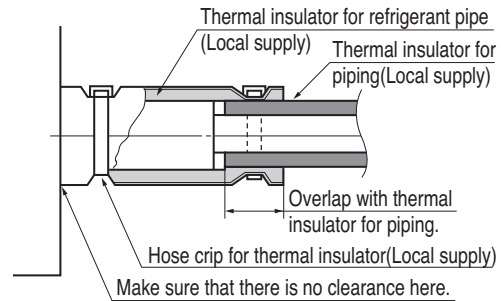
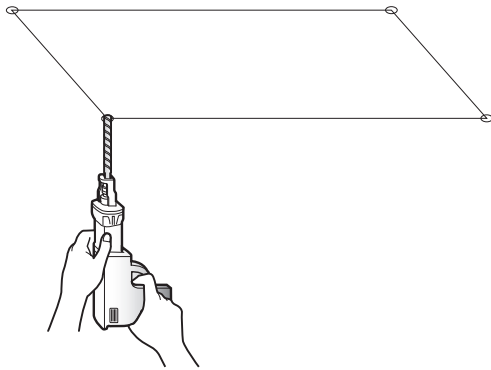

CAUTION

- Tighten the nut and bolt to prevent unit falling

- Insert the set anchor and washer onto the suspension bolts for locking the suspension bolts on the ceiling.
- Mount the suspension bolts to the set anchor firmly.
- Secure the installation plates onto the suspension bolts (adjust level roughly) using nuts, washers and spring washers.

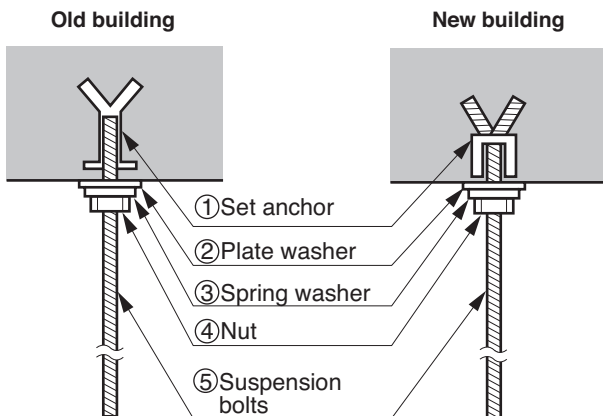

Checking the Drainage

Check the drainage.

- Spray one or two glasses of water upon the Condenser.
- Ensure that water flows drain hose of Heat Exchanger Module without any leakage.

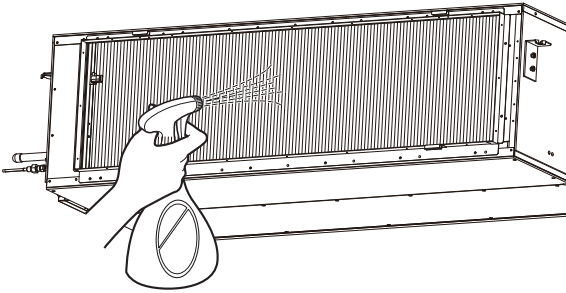

CAUTION

1. Install declination of the indoor unit is very important for the drain of the duct type air conditioner.
2. Minimum thickness of the insulation for the connecting pipe shall be 5mm.

Front of view

- The unit must be horizontal or declined to the drain hose connected when finished installation.

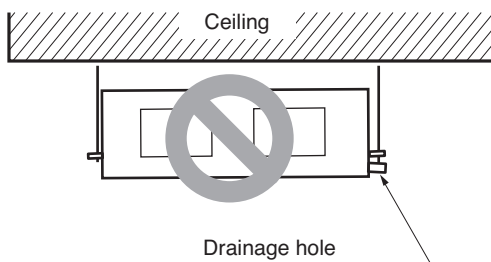
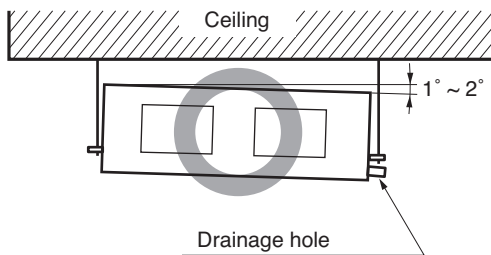

Indoor Unit Drain Piping

- Drain piping must have down-slope (1/50 to 1/100): be sure not to provide up-and-down slope to prevent reversal flow.
- During drain piping connection, be careful not to exert extra force on the drain port on the Heat Exchanger Module.
- The outside diameter of the drain connection on the Heat Exchanger Module is 32mm.

Piping material: Polyvinyl chloride pipe inner diametes Ø 25mm and pipe fittings

- Be sure to install heat insulation on the drain piping.

Heat insulation material: Polyethylene foam with thickness more than 8 mm.

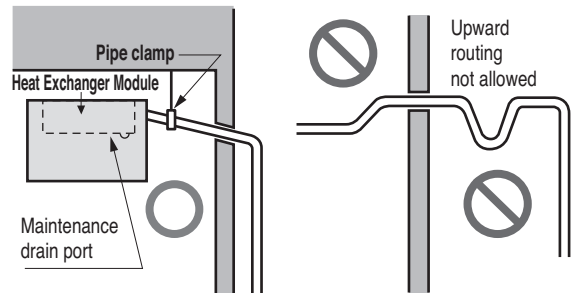

CAUTION

The supplied flexible drain hose should not be strained. A strained hose may cause leakage of water.

- Connect the main drain pipe to the exterior and leave it provisionally until the test comes to an end.
- Feed water to the flexible drain hose and check the piping for leakage.
- When the test is complete, connect the flexible drain hose to the drain port on the Heat Exchanger Module.

Method when insatalling the ducting

CAUTION

- Do not allow suction air to leaked indoors.

- Ducting is to be field supplied
- For prevent water from flowing into the Heat exchanger module, Make sure the ducting has slopes down
- You Protect the ducting against reverse airflow from wind.

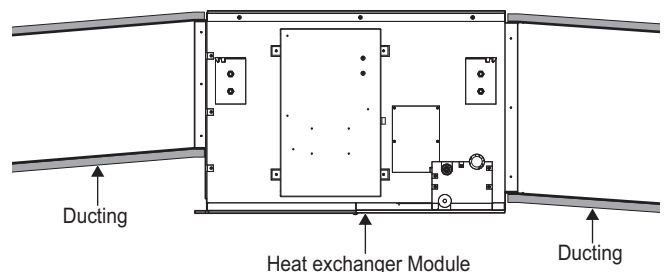

- If the suction ducting or discharge ducting is connected with the inside air, it might be impossible to reach the desired room temperature.
- Install in a place covered from rain.
- Install where it is easy to install the duct for outside air introduction.
- Install grills (Field supply) in the suction ducting entrance and the discharge ducting exit to prevent animals and debris from going into the ducting.

Method connect the refrigerant piping to the Heat Exchanger Module.

1. Cut the liquid pipe and gas pipe.

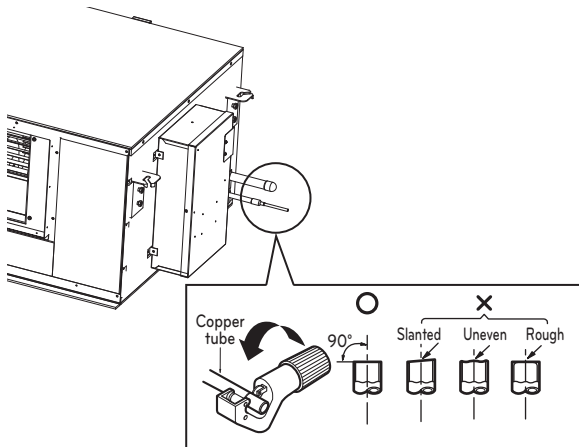

2. Burrs removal

- Completely remove all burrs from the cut cross section of pipe/tube.
- Put the end of the copper tube/pipe to downward direction as you remove burrs in order to avoid to let burrs drop in the tubing.

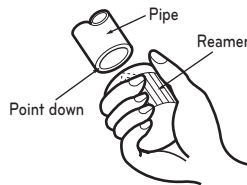

3. Wrap the pipe with a wet cloth.

4. Braze the liquid pipe and gas pipe.

5. Remove the wet cloth.

Preparation of Piping

Main cause of gas leakage is defect in flaring work. Carry out correct flaring work in the following procedure.

Cut the pipes and the cable

- Use the accessory piping kit or the pipes purchased locally.
- Measure the distance between the indoor and the MULTI V M.
- Cut the pipes a little longer than measured distance.
- Cut the cable 1.5m longer than the pipe length.

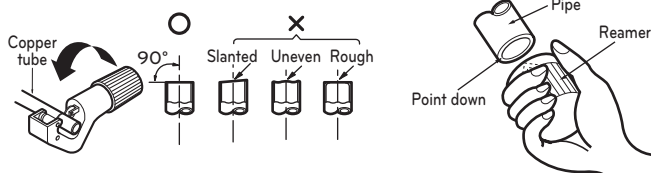

Burrs removal

- Completely remove all burrs from the cut cross section of pipe/tube.
- Put the end of the copper tube/pipe to downward direction as you remove burrs in order to avoid to let burrs drop in the tubing.

Plumbing materials and storage methods

Pipe must be able to obtain the specified thickness and should be used with low impurities.

Also when handling storage, pipe must be careful to prevent a fracture, deformity and wound.

Should not be mixed with contaminations such as dust, moisture.

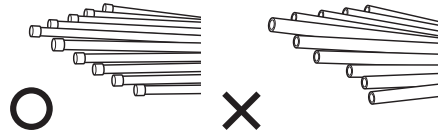

Refrigerant piping on three principles

	Drying	Cleanliness	Airtight
	Should be no moisture inside	No dust inside.	There is no refrigerant leakage
Items			
Cause failure	<ul style="list-style-type: none"> - Significant hydrolysis of refrigerant oil - Degradation of refrigerant oil - Poor insulation of the compressor - Do not cold and warm - Clogging of EEV, Capillary 	<ul style="list-style-type: none"> - Degradation of refrigerant oil - Poor insulation of the compressor - Do not cold and warm - Clogging of EEV, Capillary 	<ul style="list-style-type: none"> - Gas shortages - Degradation of refrigerant oil - Poor insulation of the compressor - Do not cold and warm
Countermeasure	<ul style="list-style-type: none"> - No moisture in the pipe - Until the connection is completed, the plumbing pipe entrance should be strictly controlled. - Stop plumbing at rainy day. - Pipe entrance should be taken side or bottom. - When removal burr after cutting pipe, pipe entrance should be taken down. - Pipe entrance should be fitted cap when pass through the walls. 	<ul style="list-style-type: none"> - No dust in the pipe. - Until the connection is completed, the plumbing pipe entrance should be strictly controlled. - Pipe entrance should be taken side or bottom. - When removal burr after cutting pipe, pipe entrance should be taken down. - Pipe entrance should be fitted cap when pass through the walls. 	<ul style="list-style-type: none"> - Airtightness test should be. - Brazing operations to comply with standards. - Flare to comply with standards. - Flange connections to comply with standards.

Nitrogen substitution method

Welding, as when heating without nitrogen substitution a large amount of the oxide film is formed on the internal piping.

The oxide film is a caused by clogging EEV, Capillary, oil hole of accumulator and suction hole of oil pump in compressor.

It prevents normal operation of the compressor.

In order to avoid this problem, Welding should be done after replacing air by nitrogen gas.

When welding plumbing pipe, the work is required.

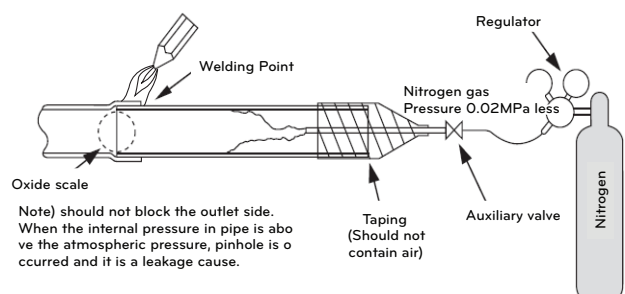

Note) should not block the outlet side. When the internal pressure in pipe is above the atmospheric pressure, pinhole is occurred and it is a leakage cause.

⚠ CAUTION

- 1 Always use the nitrogen. (not use oxygen, carbon dioxide, and a Chevron gas): Please use the following nitrogen pressure 0.02MPa Oxygen – Promotes oxidative degradation of refrigerant oil. Because it is flammable, it is strictly prohibited to use Carbon dioxide – Degrade the drying characteristics of gas Chevron Gas – Toxic gas occurs when exposed to direct flame.
- 2 Always use a pressure reducing valve.
- 3 Please do not use commercially available antioxidant. The residual material seems to be the oxide scale is observed. In fact, due to the organic acids generated by oxidation of the alcohol contained in the anti-oxidants, ant nest corrosion occurs. (causes of organic acid → alcohol + copper + water + temperature)

REFRIGERANT PIPING INSTALLATION

Precautions on Pipe connection / Valve operation

Pipe connection is done by connecting from the end of the pipe to the branching pipes, and the refrigerant pipe coming out of the Compressor Module is divided at the end to connect to each indoor unit. Flare connection for the indoor unit, and welding connection for the Compressor Module pipe and the branching parts.

- Use hexagonal wrench to open/close the valve.

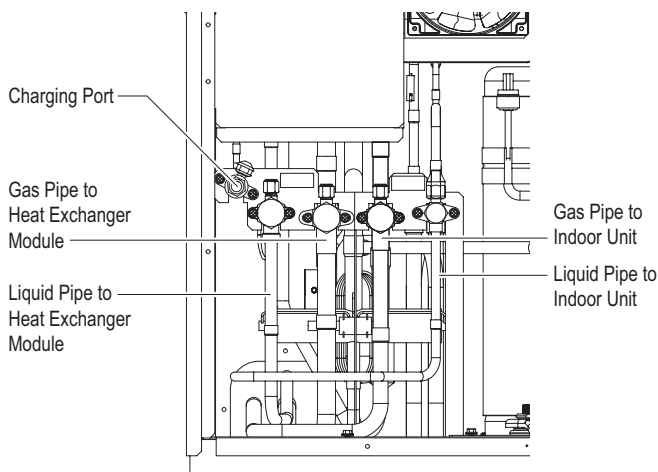

⚠ WARNING

- Always careful not to leak the refrigerant during welding.
- The refrigerant generates poisonous gas harmful to human body if combusted.
- Do not perform welding in a closed space.
- Be sure to close the cap of the service port to prevent gas leakage after the work.

⚠ CAUTION

Please block the pipe knock outs of the front and side panels after installing the pipes.
(Animals or foreign objects may be brought in to damage wires.)

TO CONNECT THE REFRIGERANT PIPING TO THE COMPRESSOR MODULE

- Pipe connections can be done on the top side or on the rear side according to installation environments.
- Be sure to let 0.2kgf/cm² Nitrogen flow in the pipe when welding.
- If Nitrogen was not flown during welding, many oxidized membranes may form inside the pipe and disturb the normal operations of valves and condensers.

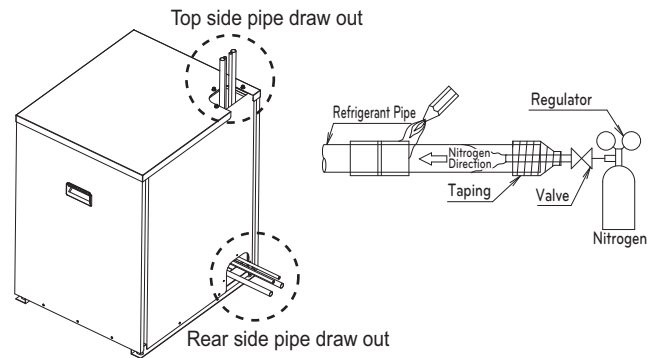

Preparation Work

- Use Knock Outs of Base Pan of the Compressor Module for Left/Right or Bottom pipe drawing outs.

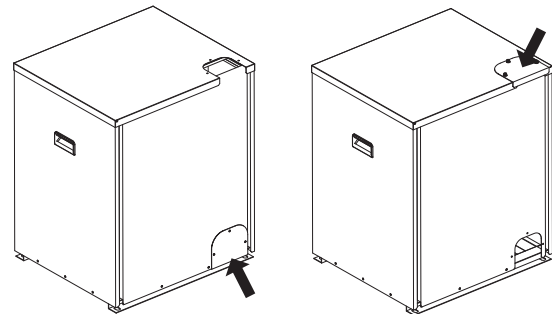

Cover the uninstalled area with a cover

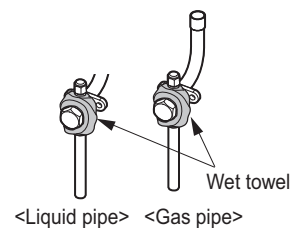

⚠ CAUTION

- Do not give damage to the pipe/base during the Knock Out work.
- Proceed to pipe work after removing burr after Knock Out work.
- Perform sleeve work to prevent damage to the wire when connecting wires using knock Outs.

Remove leakage prevention cap

- Remove the leakage prevention cap attached to the MULTI V M service valve before pipe work.
- Proceed the leakage prevention cap removal as follows:
 - Verify whether the liquid/gas pipes are locked.
 - Extract remaining refrigerant or air inside using the service port.
 - Remove the leakage prevention cap

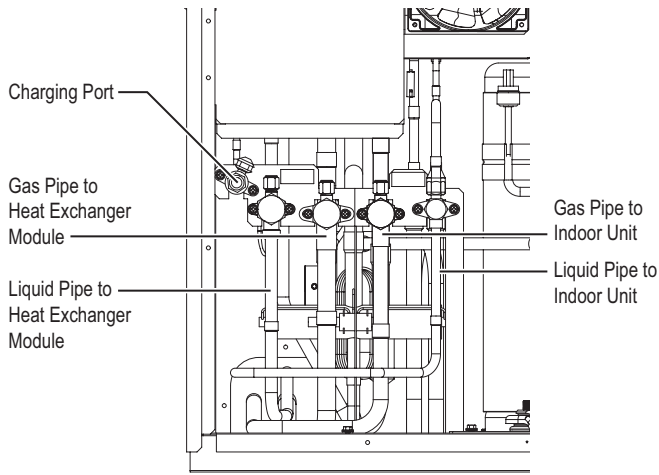

Pipe Drawing Out

Method of out pipes on the top side

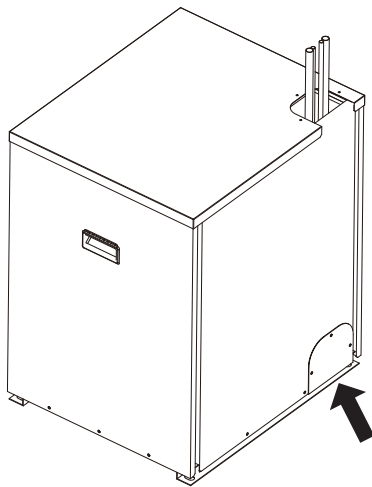

Close the cover with the screw.

NOTE

- When installing with the upper piping, the accessory piping should be 150 ~ 200mm length

Method of drawing out pipes on the rear side

- Proceed with the pipe work as shown in the below figure for rear side pie drawing out.

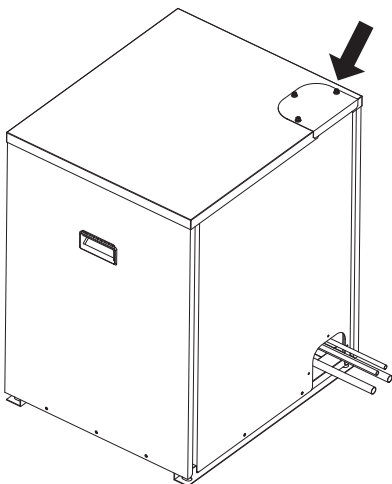

Close the cover with the screw.

Selection of Refrigerant Piping

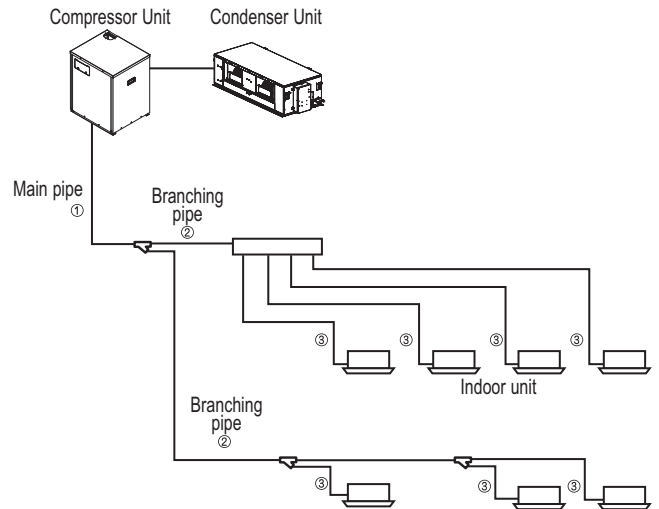

Piping parts	① MULTI V M → 1st branching section ② Branching section → Branching section ③ Branching section → Indoor unit		
Name	① Main pipe ② Branching pipe ③ Indoor unit connecting pipe		
Selection of pipe size	① Size of main pipe		
	MULTI V M capacity[HP]	Liquid pipe [mm(inch)]	Gas pipe [mm(inch)]
	5	Ø9.52(3/8)	Ø15.88(5/8)
Selection of pipe size	② Pipe size of between branching sections		
	Indoor unit capacity [kW(Btu/h)]	Liquid pipe [mm(inch)]	Gas pipe [mm(inch)]
	≤ 5.6(19,100) < 16.0(54,600)	Ø6.35(1/4) Ø9.52(3/8)	Ø12.7(1/2) Ø15.88(5/8)
Selection of pipe size	③ Connecting pipe size of indoor unit		
	Indoor unit capacity [kW(Btu/h)]	Liquid pipe [mm(inch)]	Gas pipe [mm(inch)]
	≤ 5.6(19,100) < 16.0(54,600)	Ø6.35(1/4) Ø9.52(3/8)	Ø12.7(1/2) Ø15.88(5/8)

Refrigerant piping system

Y branch method

- Ⓐ : Compressor Module
- Ⓑ : Heat Exchanger Module
- Ⓒ : 1st branch (Y branch)
- Ⓔ : Indoor Units

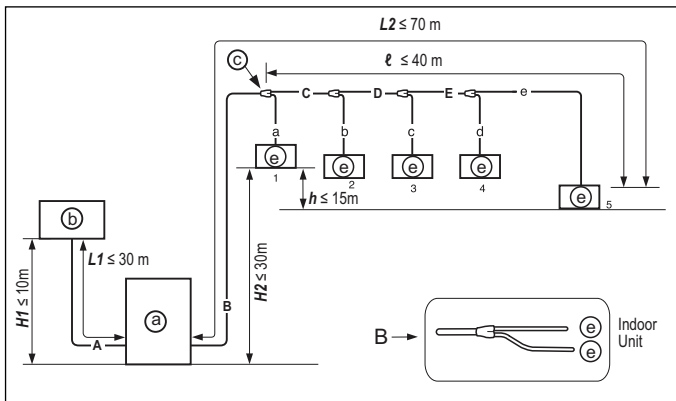

Combination of Y branch / header

- Ⓐ : Compressor Module
- Ⓑ : Heat Exchanger Module
- Ⓒ : 1st branch (Y branch)
- Ⓓ : Y branch
- Ⓔ : Indoor Units
- Ⓕ : Header
- Ⓖ : Sealed piping

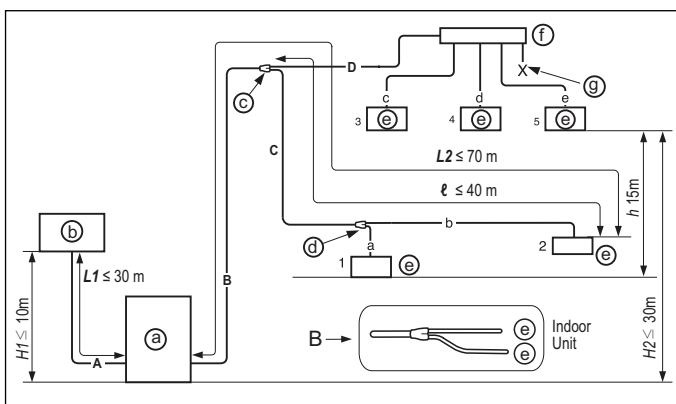

Header method

- Ⓐ : Compressor Module
- Ⓑ : Heat Exchanger Module
- Ⓕ : Header
- Ⓖ : Sealed piping

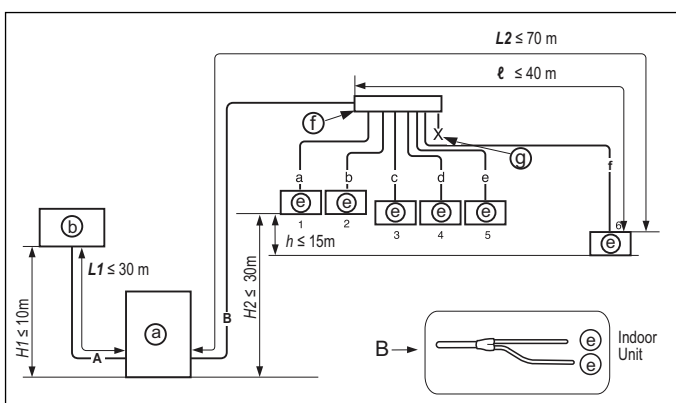

! WARNING

- Branch pipe can not be used after header.
- Pipe length after header branching
 - It is recommended that difference in length of the pipes connected to the indoor units (a~f) is minimized. Performance difference between indoor units may occur.
 - Indoor units should be installed at lower position than the header.

Limits of pipe length and difference in height

Connection method	Mark	Y branch only	Combination of Y branch / header	Header only	
Max. pipe length	Longest pipe length : Heat Exchanger Module ↔ Compressor Module	L1	A ≤ 30 m	A ≤ 30 m	A ≤ 30 m
	Longest pipe length : Compressor Module ↔ Indoor Unit	L2	B+C+D+E+e ≤ 70 m	B+C+b ≤ 70 m B+D+e ≤ 70 m	B+f ≤ 70 m
	Longest pipe equivalent length* : Compressor Module ↔ Indoor Unit	L2*	90 m	90 m	90 m
	Longest pipe length after 1st branch	ℓ	30 m	30 m	30 m
	Total pipe length	-	A+B+C+D+E+e ≤ 140 m	A+B+C+D+a+b+c+d+e ≤ 140 m	A+B+a+b+c+d+e+f ≤ 140 m
Max. difference in height	Difference in height : Compressor Module ↔ HEX Module	H1	10 m	10 m	10 m
	Difference in height : Compressor Module ↔ Indoor Unit	H2	30 m	30 m	30 m
	Difference in height : Indoor Unit ↔ Indoor Unit	h	15 m	15 m	15 m

! NOTE

- * : Assume equivalent piping length of Y branch to be 0.5m, that of header to be 1m, calculation purpose.

! WARNING

- When the below condition is satisfied, the diameter of main pipe (B : Compressor Module ↔ 1 st Branch) must be increased according to below table.
 - The equivalent length between Heat Exchanger Module and the farthest indoor unit is 90m or more (Liquid / Gas pipes are increased in accordance with below tables)

! WARNING

- It is recommended that difference of piping length for pipes connected to the Indoor Unit is minimized. Performance difference between Indoor Units may occur.
- When the any one (or both) of below conditions are satisfied, the diameter of main pipe (A) must be increased according to below table.
 - The equivalent length between MULTI V M and the farthest indoor unit is 90m or more (Liquid and Gas pipes are increased)

Refrigerant pipe diameter from MULTI V M to first branch. (A)

MULTI V M total capacity(HP)	Liquid pipe [mm(inch)]	Gas pipe [mm(inch)]
5	Ø9.52(3/8)	Ø15.88(5/8)

Refrigerant pipe diameter from branch to branch (B,C)

Downward Indoor Unit total capacity [kW(Btu/h)]	Liquid pipe [mm(inch)]	Gas pipe [mm(inch)]
≤ 5.6(19,100)	Ø6.35(1/4)	Ø12.7(1/2)
< 16.0(54,600)	Ø9.52(3/8)	Ø15.88(5/8)

Indoor Unit Connection

Indoor Unit connecting pipe from branch (a,b,c,d,e,f)

Indoor Unit capacity [kW(Btu/h)]	Liquid pipe [mm(inch)]	Gas pipe [mm(inch)]
≤ 5.6(19,100)	Ø6.35(1/4)	Ø12.7(1/2)
< 16.0(54,600)	Ø9.52(3/8)	Ø15.88(5/8)

CAUTION

- Bending radius should be at least twice the diameter of the pipe.
- Bend pipe after 500 mm or more from branch(or header). Do not bend U type. It may cause Performance unsatisfactory or noise.
- If want U type, bending R is more than 200 mm.

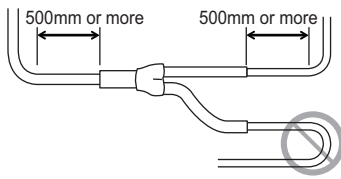

The amount of Refrigerant

The calculation of the additional charge should take into account the length of pipe and CF(correction Factor) value of indoor unit.

Additional charge (kg)	= L1(m) : Total length of liquid pipe with Ø12.7mm × 0.118 (kg/m)
Important	
Check the Total length between Heat Exchanger Module ~ Compressor Module ~ Indoor Unit	
+ L2(m) : Total length of liquid pipe with Ø9.52mm	× 0.061 (kg/m)
+ L3(m) : Total length of liquid pipe with Ø6.35mm	× 0.022 (kg/m)
+ CF value of Heat Exchanger Module (1 kg)	
+ CF value of Indoor unit *	

NOTE

- * : For CF value (additional refrigerant) table of indoor units, please refer to PDB of indoor unit.

Attach the additional refrigerant table of IDU.

CAUTION

Use only 4-series of indoor unit. Ex) ARNU***2
Do not connect Hydrokit.

WARNING

- Regulation for refrigerant leakage : the amount of refrigerant leakage should satisfy the following equation for human safety.

$$\frac{\text{Total amount of refrigerant in the system}}{\text{Volume of the room at which Indoor Unit of the least capacity is installed}} \leq 0.44 \text{ (kg/m}^3\text{)}$$

If the above equation can not be satisfied, then follow the following steps.

- Selection of air conditioning system: select one of the next
 - Installation of effective opening part
 - Reconfirmation of MULTI V M capacity and piping length
 - Reduction of the amount of refrigerant
 - Installation of 2 or more security device (alarm for gas leakage)
- Change Indoor Unit type
 - : installation position should be over 2m from the floor (Wall mounted type → Cassette type)
- Adoption of ventilation system
 - : choose ordinary ventilation system or building ventilation system
- Limitation in piping work
 - : Prepare for earthquake and thermal stress

Refrigerant charging

- Ⓐ Manifold Gauge
- Ⓑ Low pressure side Handle
- Ⓒ High pressure side Handle

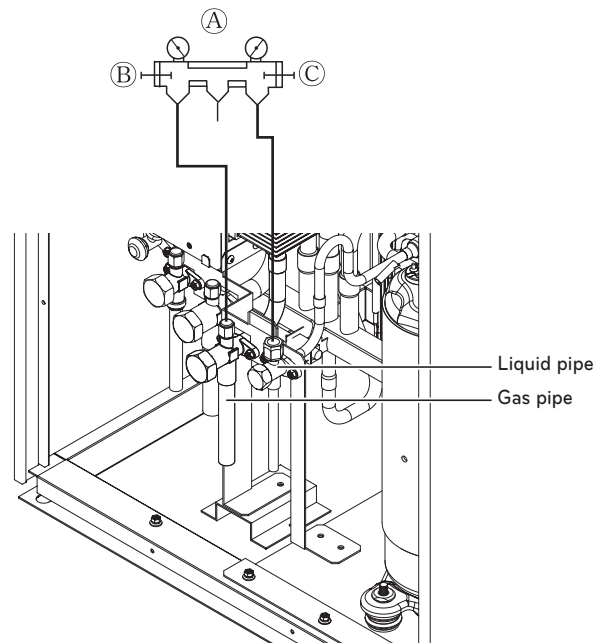

WARNING

- Pipe to be vacuumed : gas pipe, liquid pipe
- If the refrigerant amount is not exact, it may not operate properly.
- If additionally bottled refrigerant amount is over 10%, condenser burst or insufficient indoor unit performance may be caused.

Distribution Method

Horizontal Distribution

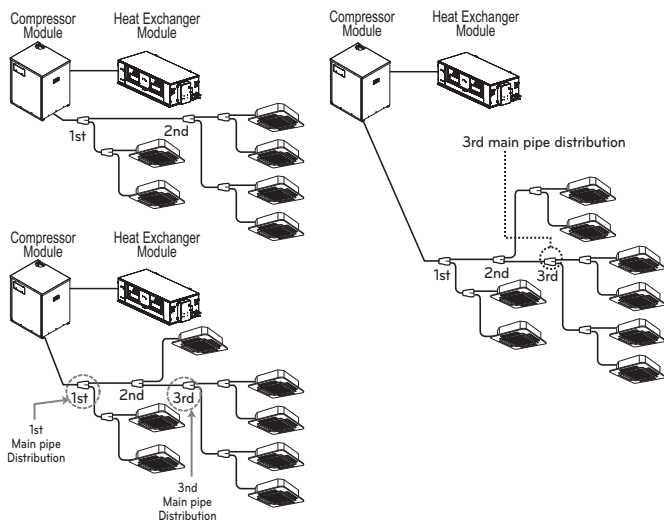

Vertical Distribution

- Ensure that the branch pipes are attached vertically.

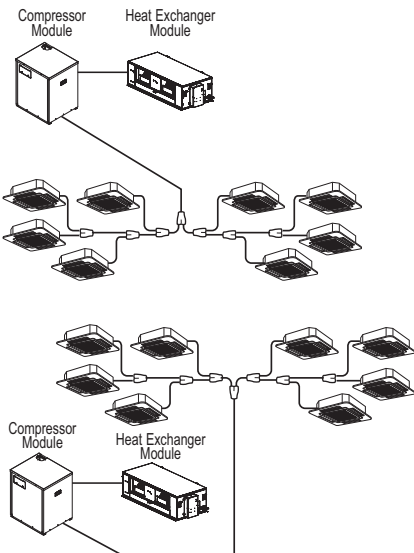

The others

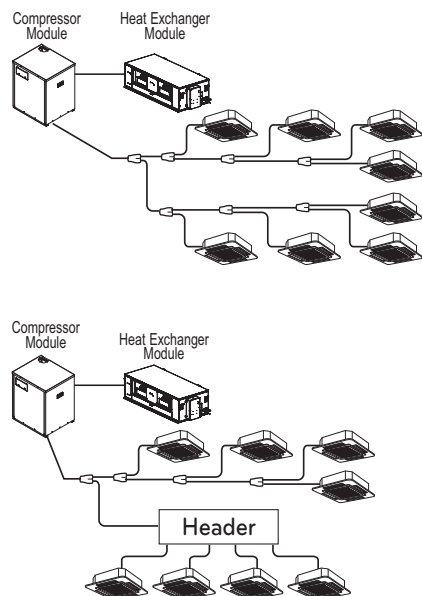

Branch pipe Fitting

Y branch

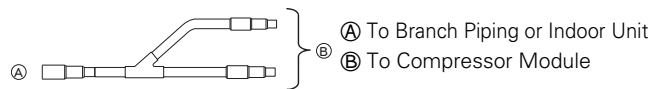

- Ensure that the branch pipes are attached horizontally or vertically (see the diagram below.)

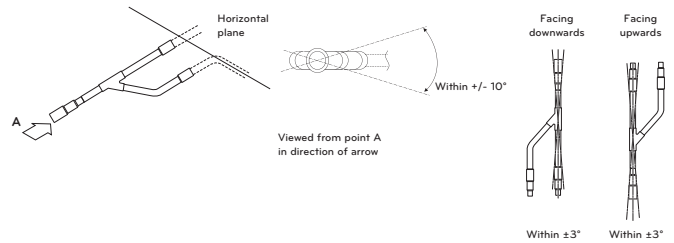

- There is no limitation on the joint mounting configuration.
- If the diameter of the refrigerant piping selected by the procedures described is different from the size of the joint, the connecting section should be cut with a pipe cutter.
- Branch pipe should be insulated with the insulator in each kit.

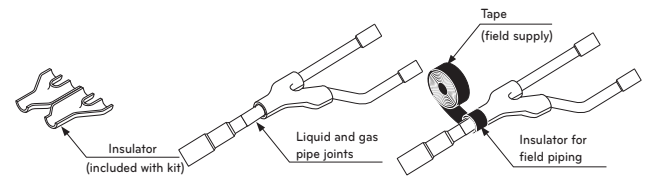

Header

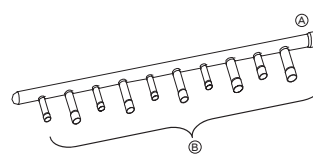

- (A) Compressor Module
- (B) To Indoor Unit

- The indoor unit having larger capacity must be installed closer to (A) than smaller one.
- If the diameter of the refrigerant piping selected by the procedures described is different from the size of the joint, the connecting section should be cut with a pipe cutter.

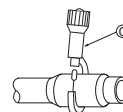

- (C) Pipe cutter

- When the number of pipes to be connected is smaller than the number of header branches, install a cap to the unconnected branches.

- When the number of indoor units to be connected to the branch pipes is less than the number of branch pipes available for connection then cap pipes should be fitted to the surplus branches.

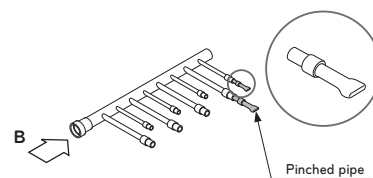

- Fit branch pipe lie in a horizontal plane.

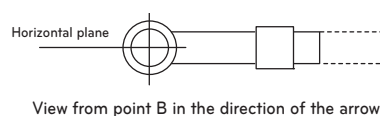

Vacuum

Vacuum drying should be made from the service port provided on the Compressor Module M's service valve to the vacuum pump commonly used for liquid pipe, gas pipe and high/low pressure common pipe. (Make Vacuum from liquid pipe, gas pipe and high/low pressure common pipe with the service valve closed.)

* Never perform air purging using refrigerant.

- Vacuum drying: Use a vacuum pump that can evacuate to -100.7kPa (5 Torr, -755mmHg).

- Evacuate the system from the liquid and gas pipes with a vacuum pump for over 2 hrs and bring the system to -100.7kPa . After maintaining system under that condition for over 1 hr, confirm the vacuum gauge rises. The system may contain moisture or leak.

- Following should be executed if there is a possibility of moisture remaining inside the pipe.
(Rainwater may enter the pipe during work in the rainy season or over a long period of time)

After evacuating the system for 2 hrs, give pressure to the system to 0.05MPa (vacuum break) with nitrogen gas and then evacuate it again with the vacuum pump for 1hr to -100.7kPa (vacuum drying). If the system cannot be evacuated to -100.7kPa within 2 hrs, repeat the steps of vacuum break and its drying. Finally, check if the vacuum gauge does not rise or not, after maintaining the system in vacuum for 1 hr.

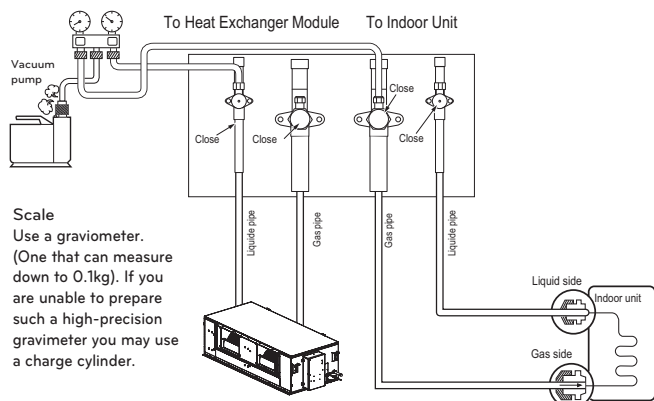

WARNING

Use a vacuum pump or inert(nitrogen) gas when doing leakage test or air purge. Do not compress air or Oxygen and do not use Flammable gases. Otherwise, it may cause fire or explosion.

- There is the risk of death, injury, fire or explosion.

NOTE

Always add an appropriate amount of refrigerant. (For the refrigerant additional charge)

Too much or too little refrigerant will cause trouble.

To use the Vacuum Mode

(If the Vacuum mode is set, all valves of Indoor units and Outside units will be opened.)

WARNING

When installing and moving the air conditioner to another site, recharge after perfect evacuation.

- If a different refrigerant or air is mixed with the original refrigerant, the refrigerant cycle may malfunction and the unit may be damaged.

Vacuum Mode

This function is used for creating vacuum in the system after compressor replacement, ODU parts replacement or IDU addition/replacement.

Vacuum mode setting method

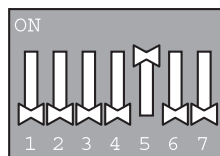

1 2 3 4 5 6 7

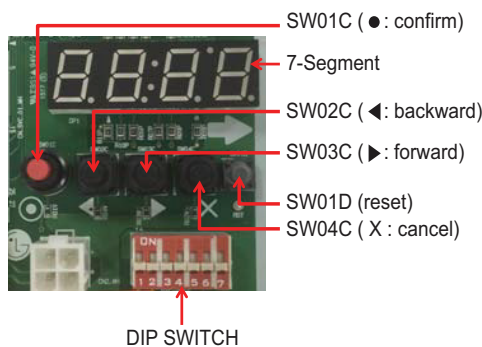

Master unit PCB DIP switch on : No.5

Select the mode using '▶', '◀' Button :
"SVC" Push the '●' button

Select the Function using '▶', '◀' Button :
"Se3" Push the '●' button

Start the vacuum mode : "VACC"

ODU V/V open

ODU EEV open

IDU EEV open

Vacuum mode off method

DIP switch off and push the reset button on Master unit PCB

CAUTION

ODU operation stops during vacuum mode. Compressor can't operate.

Thermal insulation of refrigerant piping

Be sure to give insulation work to refrigerant piping by covering liquid pipe and gas pipe separately with enough thickness heat-resistant polyethylene, so that no gap is observed in the joint between indoor unit and insulating material, and insulating materials themselves. When insulation work is insufficient, there is a possibility of condensation drip, etc. Pay special attention to insulation work to ceiling plenum.

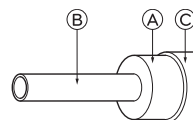

Heat insulation material	Adhesive + Heat - resistant polyethylene foam + Adhesive tape	
Outer covering	Indoor	Vinyl tape
	Floor exposed	Water-proof hemp cloth + Bronze asphalt
	MULTI V M	Water-proof hemp cloth + Zinc plate + Oily paint

- (A) Heat insulation material
- (B) Pipe
- (C) Outer covering(Wind the connection part and cutting part of heat insulation material with a finishing tape.)

NOTE

When using polyethylene cover as covering material, asphalt roofing shall not be required.

Penetrations

Inner wall (concealed)

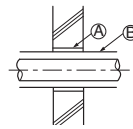

Outer wall

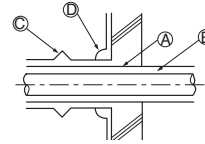

Outer wall (exposed)

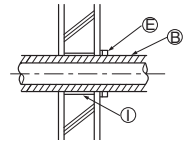

Floor (fireproofing)

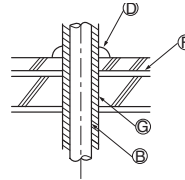

Penetrating portion on fire limit and boundary wall

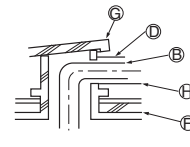

Roof pipe shaft

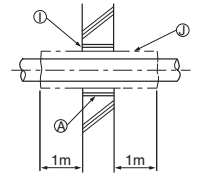

- (A) Sleeve
- (B) Heat insulating material
- (C) Lagging
- (D) Caulking material
- (E) Band
- (F) Waterproofing layer
- (G) Sleeve with edge
- (H) Lagging material
- (I) Mortar or other incombustible caulking
- (J) Incombustible heat insulation material

When filling a gap with mortar, cover the penetration part with steel plate so that the insulation material will not be caved in. For this part, use incombustible materials for both insulation and covering. (Vinyl covering should not be used.)

Bad example

- Do not insulate gas or low pressure pipe and liquid or highpressure pipe together.

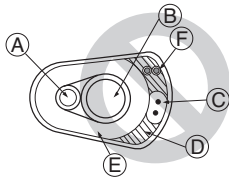

- (A) Liquid pipe
- (B) Gas pipe
- (C) Power lines
- (D) Finishing tape
- (E) Insulating material
- (F) Communication lines

- Be sure to fully insulate connecting portion.

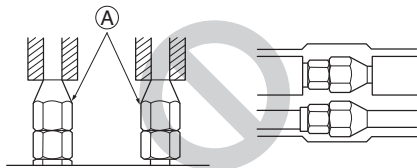

(A) These parts are not insulated.

Good example

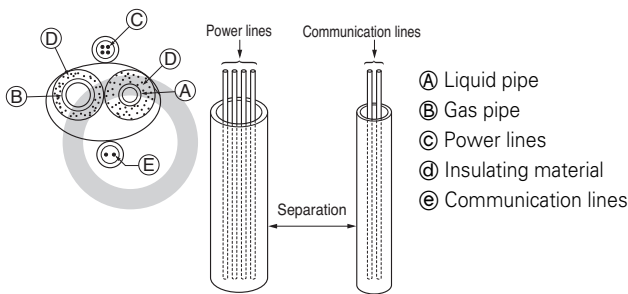

- (A) Liquid pipe
- (B) Gas pipe
- (C) Power lines
- (D) Insulating material
- (E) Communication lines

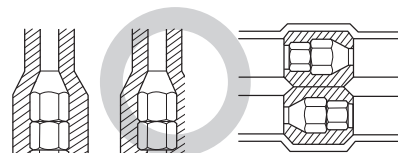

ELECTRICAL WIRING

Caution

- Follow ordinance of your governmental organization for technical standard related to electrical equipment, wiring regulations and guidance of each electric power company.

WARNING

Be sure to have authorized electrical engineers do the electric work using special circuits in accordance with regulations and this installation manual.
If power supply circuit has a lack of capacity or electric work deficiency, it may cause an electric shock or fire.

- Install the Compressor Module communication cable away from the power source wiring so that it is not affected by electric noise from the power source. (Do not run it through the same conduit.)
- Be sure to provide designated grounding work to MULTI V M.
- The installation of a residual current device(RCD) having a rated residual operating current not exceeding 30 mA is advisable.

CAUTION

Be sure to correct the MULTI V M to earth. Do not connect ground wire to any gas pipe, liquid pipe, lightning rod or telephone earth line. If earth is incomplete, it may cause an electric shock.

- Give some allowance to wiring for electrical part box of Indoor and Outside Units, because the box is sometimes removed at the time of service work.
- Communication between the compressor module and the condenser module must be connected at a fixed site on the terminal block.
- Never connect the main power source to terminal block of communication cable. If connected, electrical parts will be burnt out.
- Use 2-core shield cable for communication cable. (○ mark in the figure below) If communication cable of different systems are wired with the same multiplecore cable, the resultant poor transmitting and receiving will cause erroneous operations. (⊗ mark in the figure below)
- Only the communication cable specified should be connected to the terminal block for MULTI V M communication.

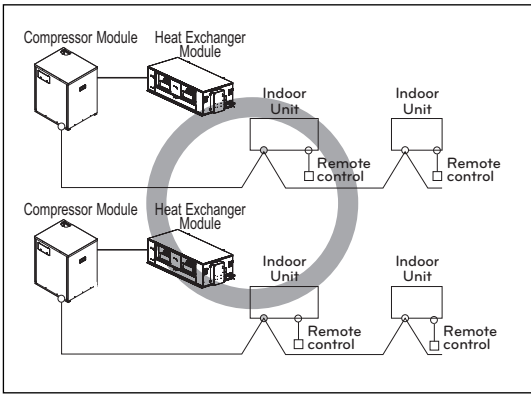

2-Core Shield Cable

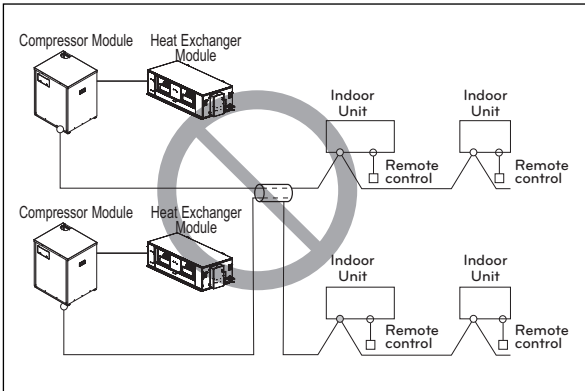

Multi-Core Cable

CAUTION

- Use the 2-core shield cables for communication cables. Never use them together with power cables.
- The conductive shielding layer of cable should be grounded to the metal part of both units.
- Never use multi-core cable
- As this unit is equipped with an inverter, to install a phase leading capacitor not only will deteriorate power factor improvement effect, but also may cause capacitor abnormal heating. Therefore, never install a phase leading capacitor.
- Make sure that the power unbalance ratio is not greater than 2%. If it is greater the units lifespan will be reduced.

Precautions when laying power wiring

Use round pressure terminals for connections to the power terminal block.

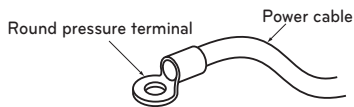

When none are available, follow the instructions below.

- Do not connect wiring of different thicknesses to the power terminal block. (Slack in the power wiring may cause abnormal heat.)
- When connecting cable which is the same thickness, do as shown in the figure below.

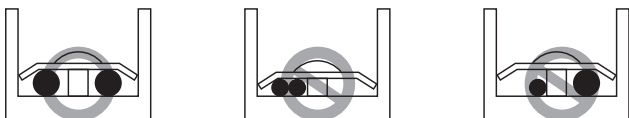

- For wiring, use the designated power cable and connect firmly, then secure to prevent outside pressure being exerted on the terminal block.
- Use an appropriate screwdriver for tightening the terminal screws. A screwdriver with a small head will strip the head and make proper tightening impossible.
- Over-tightening the terminal screws may break them.

CAUTION

When the 400 volt power supply is applied to "N" phase by mistake, check damaged parts in control box and replace them.

Control box and connecting position of wiring

- Remove all of the screws at front panel and remove the panel by pulling it forward.
- Connect to Communication wire on terminal block (From Compressor module, Heat Exchanger Module and Indoor Unit)
- When the central control system is connected to the MULTI V M, a dedicated PCB must be connected between them.
- When connecting communication cable between MULTI V M and indoor units with shielded cable, connect the shield ground to the earth screw.

Compressor Module

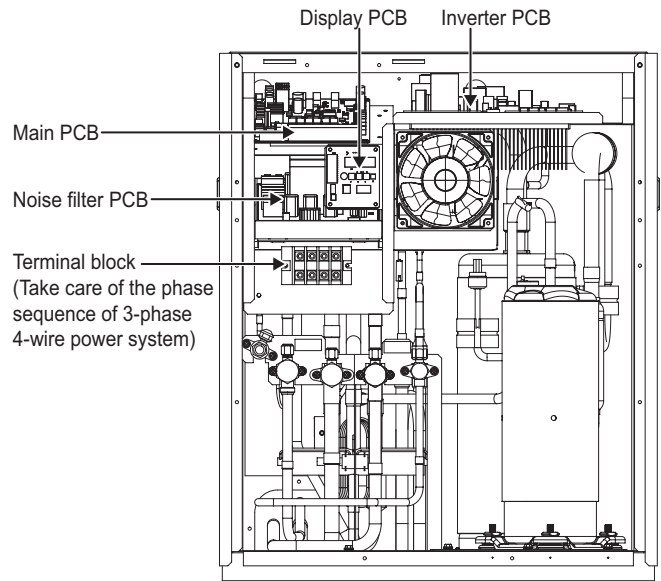
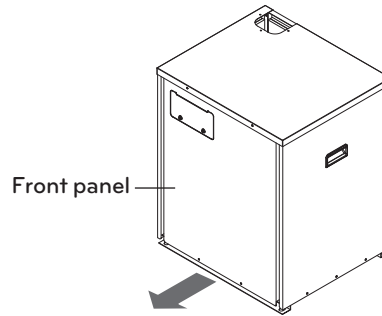

Heat Exchanger Module

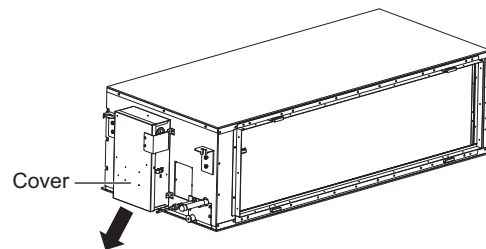

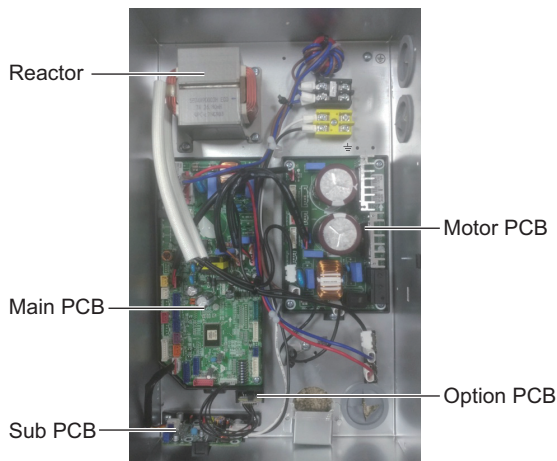

Communication and Power Cables

Communication cable

- Types : shielding cable
- Cross section : 1.0~1.5mm²
- Maximum allowable temperature: 60°C
- Maximum allowable cable length: under 300m

Remote control cable

- Types : 3-core cable

Central control cable

Product type	Cable type	Diameter
ACP	2-core cable (Shielding cable)	1.0~1.5mm ²
AC Smart	2-core cable (Shielding cable)	1.0~1.5mm ²
AC Ez	4-core cable (Shielding cable)	1.0~1.5mm ²

Separation of communication and power cables

- If communication and power cables are run alongside each other then there is a strong likelihood of operational faults developing due to interference in the signal wiring caused by electrostatic and electromagnetic coupling.

The tables below indicates our recommendation as to appropriate spacing of communication and power cables where these are to be run side by side

Current capacity of power cable		Spacing
100V or more	10A	50mm

NOTE

- The figures are based on assumed length of parallel cabling up to 100m. For length in excess of 100m the figures will have to be recalculated in direct proportion to the additional length of cable involved.
- If the power supply waveform continues to exhibit some distortion the recommended spacing in the table should be increased.
 - If the cable are laid inside conduits then the following point must also be taken into account when grouping various cable together for introduction into the conduits
 - Power cable(including power supply to air conditioner) and communication cables must not be laid inside the same
 - In the same way, when grouping the power wires and communication cables should not be bunched together.

CAUTION

If apparatus is not properly earthed then there is always a risk of electric shocks, the earthing of the apparatus must be carried out by a qualified person.

Wiring of main power supply and equipment capacity

- Use a separate power supply for the Compressor Module, Heat Exchanger Module and Indoor Unit.
- Bear in mind ambient conditions (ambient temperature, direct sunlight, rain water, etc.) when proceeding with the wiring and connections.
- The cable size is the minimum value for metal conduit wiring. The power cord size should be 1 rank thicker taking into account the line voltage drops. Make sure the power-supply voltage does not drop more than 10%.
- Specific wiring requirements should adhere to the wiring regulations of the region.
- Power supply cords of parts of appliances for Compressor Module, Heat Exchanger Module use should not be lighter than polychloroprene sheathed flexible cord.
- Don't install an individual switch or electrical outlet to disconnect each of indoor unit separately from the power supply.

WARNING

- Follow ordinance of your governmental organization for technical standard related to electrical equipment, wiring regulations and guidance of each electric power company.
- Make sure to use specified cables for connections so that no external force is imparted to terminal connections. If connections are not fixed firmly, it may cause heating or fire.
- Make sure to use the appropriate type of overcurrent protection switch. Note that generated overcurrent may include some amount of direct current.

CAUTION

- Some installation site may require attachment of an earth leakage breaker. If no earth leakage breaker is installed, it may cause an electric shock.
- Do not use anything other than breaker and fuse with correct capacity. Using fuse and wire or copper wire with too large capacity may cause a malfunction of unit or fire.

Field Wiring

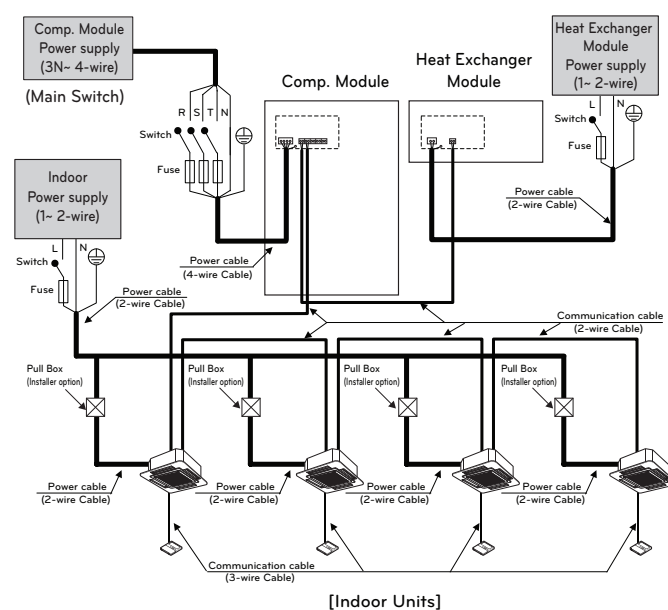

Frequency	Voltage range(V)		
	Comp. Module	Heat Exchanger Module	Indoor Unit
50Hz	380~415V	220~240V	220~240V

[Heat Pump]

Between Indoor unit and MULTI V M

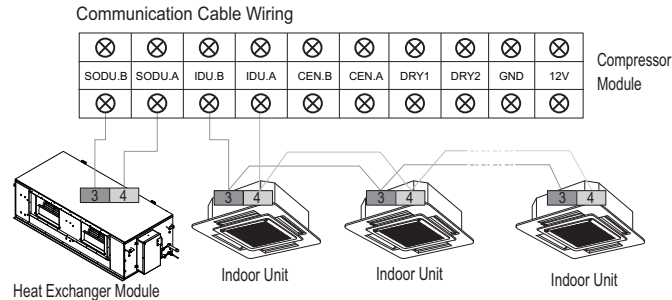

The GND terminal at the main PCB is a '-' terminal for dry contact, it is not the point to make ground connection.

WARNING

- Indoor Unit ground wires are required for preventing electrical shock accident during current leakage, Communication disorder by noise effect and motor current leakage (without connection to pipe).
- Don't install an individual switch or electrical outlet to disconnect each of indoor unit separately from the power supply.
- Install the main switch that can interrupt all the power sources in an integrated manner because this system consists of the equipment utilizing the multiple power sources.
- If there exists the possibility of reversed phase, lose phase, momentary blackout or the power goes on and off while the product is operating, attach a reversed phase protection circuit locally. Running the product in reversed phase may break the compressor and other parts.

Example) Connection of transmission wire

[BUS type]

- Connection of communication cable must be installed like below figure between indoor unit to MULTI V M.

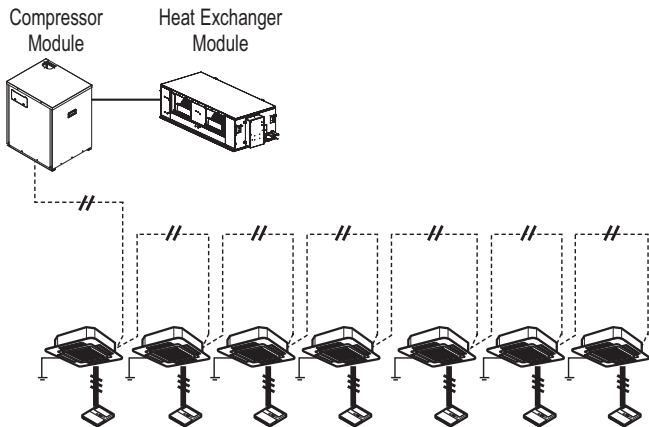

[STAR type]

- Abnormal operation can be caused by communication defect, when connection of communication cable is installed like below figure(STAR type).

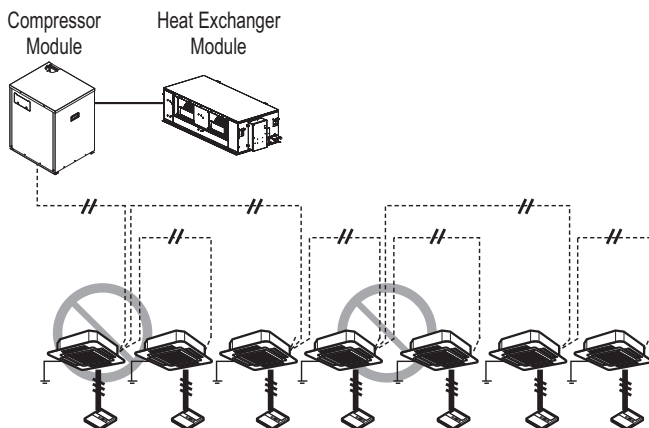

Example) Connection of power and communication cable

- Case of Rear side pipe draw out.

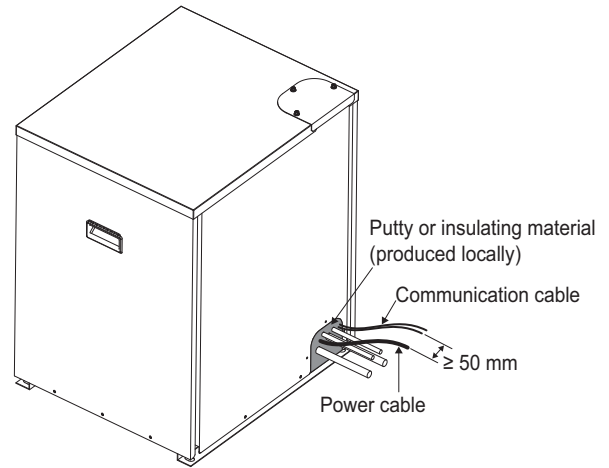

- Case of Top side pipe draw out.

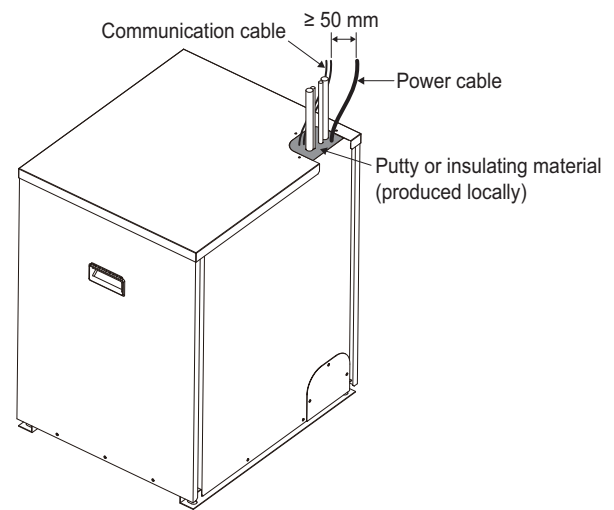

CAUTION

- Insects or small animals entering the Compressor module may cause a short circuit in the electrical box.
- Plug the pipe through-holes with putty or insulation material(procured locally)to stop up all gaps.

Compressor Module

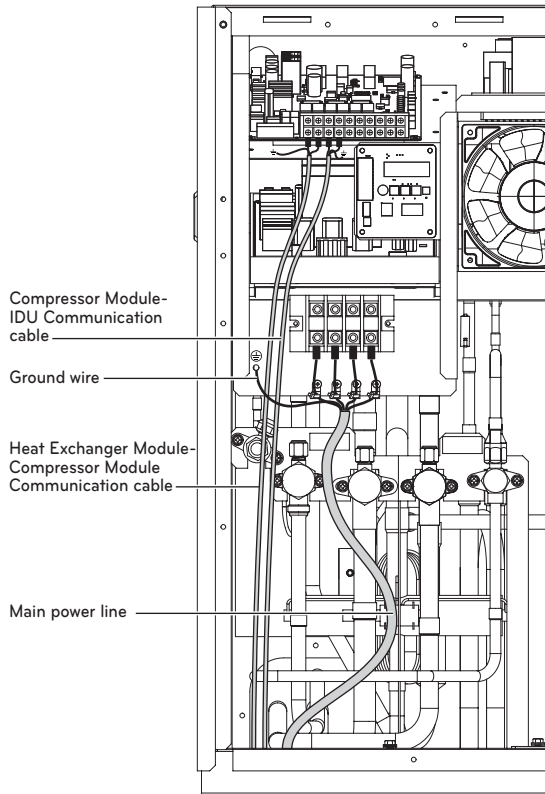

Side view

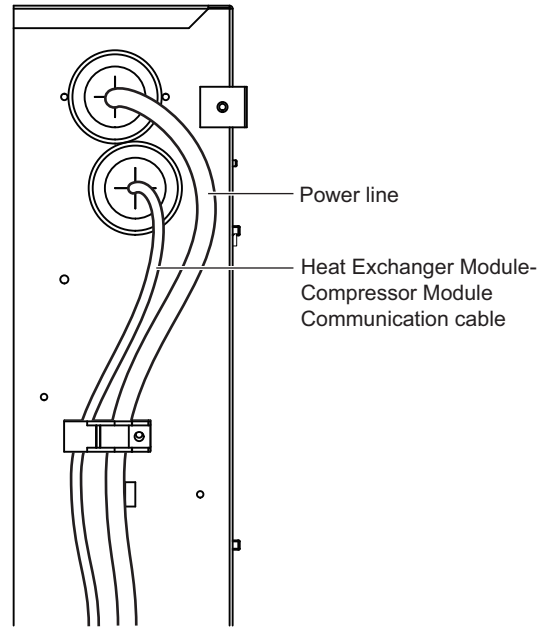

Heat Exchanger Module

Front view

Notice

This model is not use remote controller.

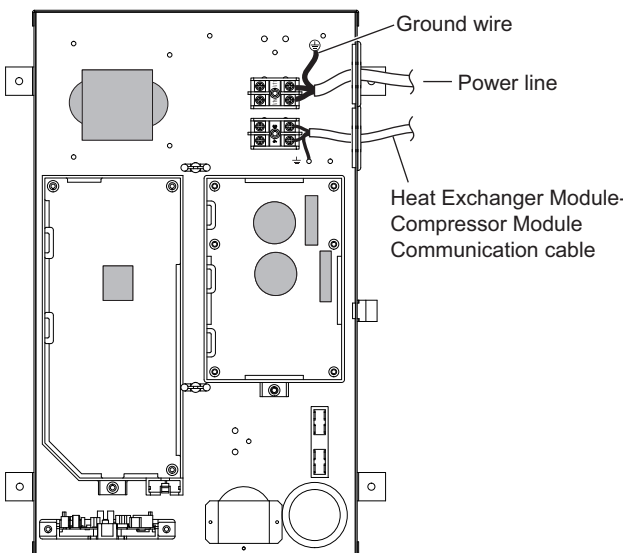

Checking the setting of outside units

Checking according to dip switch setting

- You can check the setting values of the Master MULTI V M from the 7 segment LED.

The dip switch setting should be changed when the power is OFF.

Checking the initial display

The number is sequentially appeared at the 7 segment in 5 seconds after applying the power. This number represents the setting condition. (For example, represents R410A 10HP)

• Initial display order

Order	No	Note
①	4~12	Model capacity
②	1	Cooling only
	2	Heat pump
③	38	380V
	46	460V
	22	220V
④	13	MULTI V M

• Example) ARUN100LSS0

①	②	③	④
10	2	38	1

Automatic Addressing

The address of indoor units would be set by Automatic Addressing

- Wait for 3 minutes after supplying power. (Master and Slave outside units, indoor units)
- Press RED button of the outside units for 5 seconds. (SW01C)
- A "88" is indicated on 7-segment LED of the Compressor Module PCB.
- For completing addressing, 2~7 minutes are required depending on numbers of connected indoor units
- Numbers of connected indoor units whose addressing is completed are indicated for 30 seconds on 7-segment LED of the Compressor Module PCB
- After completing addressing, address of each indoor unit is indicated on the wired remote control display window. (CH01, CH02, CH03,, CH06 : Indicated as numbers of connected indoor units)

[Heat Pump (MAIN PCB)]

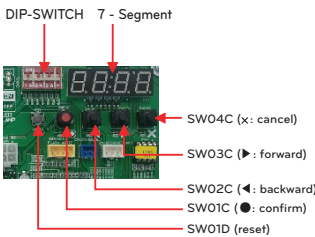

CAUTION

- In replacement of the indoor unit PCB, always perform Automatic addressing setting again (At that time, please check about using Independent power module to any indoor unit.)
- If power supply is not applied to the indoor unit, operation error occur.
- Automatic Addressing is only possible on the master Unit.
- Automatic Addressing has to be performed after 3 minutes to improve communication.

The Procedure of Automatic Addressing

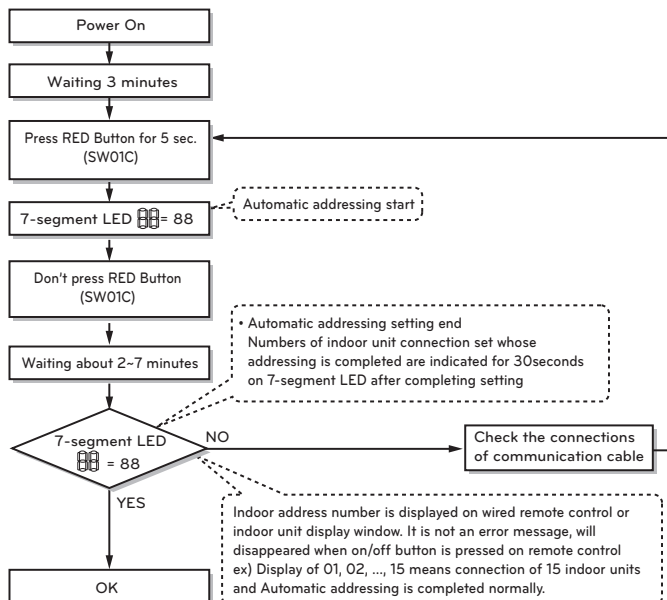

Setting the function

Select the mode/function/option/value using '▶', '◀' Button and confirm that using the '●' button after DIP switch No.5 is turned on.

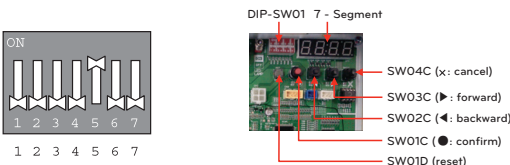

Mode	Function	Option	Value	Action	Remarks						
Content	Display1	Content	Display2	Content	Display3	Content	Display4	Implement	Display5		
Installation	Func	Cool & Heat Selector	Fn1	oFF	oP1~oP2	Selected the option	-	-	Change the set value	Blank	Save in EEPROM
		Static pressure compensation	Fn2	oFF	oP1~oP3	Selected the option	-	-	Change the set value	Blank	Save in EEPROM
		Night low noise	Fn3	oFF	oP1~oP12	Selected the option	-	-	Change the set value	Blank	Save in EEPROM
		ODU address	Fn5	-	-	-	0~255	set the value	Change the set value	Blank	Save in EEPROM
		Snow removal & rapid defrost	Fn6	oFF	oP1~oP3	Selected the option	-	-	Change the set value	Blank	Save in EEPROM
		Target pressure adjusting	Fn8	oFF	oP1~oP3	Selected the option	-	-	Change the set value	Blank	Save in EEPROM

* Functions save in EEPROM will be kept continuously, though the system power was reset.

* DIP switch 3 can be OFF except when installing the only 4 series indoor units (named ARNU***4).

Group Number setting

Group Number setting for Indoor Units

- Confirm the power of whole system Indoor Unit, Compressor Module is OFF, otherwise turn off.
- The communication cables connected to CEN.A and CEN.B terminal should be connected to central control of Compressor Module with care for their polarity (A-A, B-B).
- Turn the whole system on.
- Set the group and Indoor Unit number with a wired remote control.
- To control several sets of Indoor Units into a group, set the group ID from 0 to F for this purpose.

Compressor Module (External PCB)

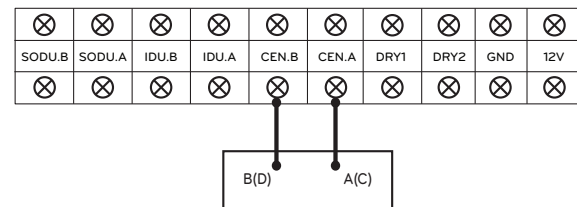

Example) Group number setting

1 E
Group Indoor unit

1st number indicate the group number
2nd number point out indoor unit number

Group recognizing the central controller	
No.0 group (00~0F)	
No.1 group (10~1F)	
No.2 group (20~2F)	
No.3 group (30~3F)	
No.4 group (40~4F)	
No.5 group (50~5F)	
No.6 group (60~6F)	
No.7 group (70~7F)	
No.8 group (80~8F)	
No.9 group (90~9F)	
No. A group (A0~AF)	
No. B group (B0~BF)	
No. C group (C0~CF)	
No. D group (D0~DF)	
No. E group (E0~EF)	
No. F group (F0~FF)	

Cool & Heat selector

Mode setting method

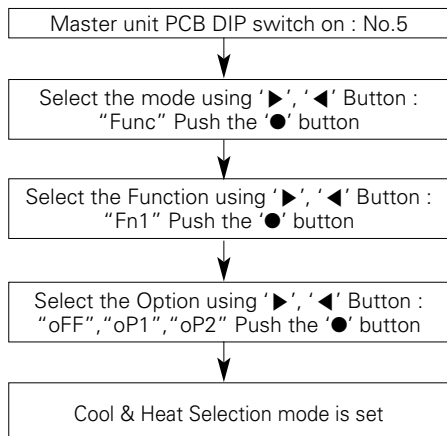

Function setting

Switch control		Function		
Switch(Phase)	Switch(Bottom)	oFF	oP1(mode)	oP2(mode)
Right	Left	Not operate	Cooling	Cooling
Right	Right	Not operate	Heating	Heating
Left	-	Not operate	Fan mode	Off

Left side | Right side

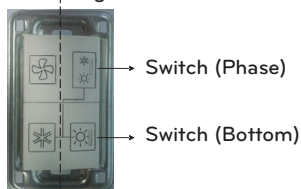

CAUTION

- Ask an authorized technician to setting a function.
- If do not use a function, set an off-mode.
- If use a function, first install a Cool & Heat selector.

Static pressure compensation mode

This function secures the air flow rate of ODU, in case static pressure has been applied like using duct at fan discharge of ODU.

Static pressure compensation mode setting method

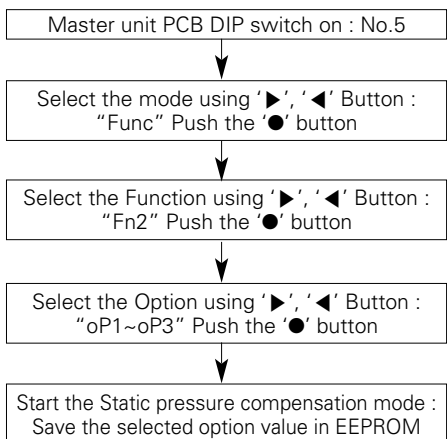

FAN Maximum RPM of each step

	DISPLAY	RPM	Static pressure(mmAq(Pa))
Max.RPM	oP1	+50	6 (58.8)
	oP2	+100	9 (88.2)
	oP3	+150	12 (117.6)

Night Low Noise Function

In cooling mode, this function makes the ODU fan operate at low RPM to reduce the fan noise of ODU at night which has low cooling load.

Night low noise function setting method

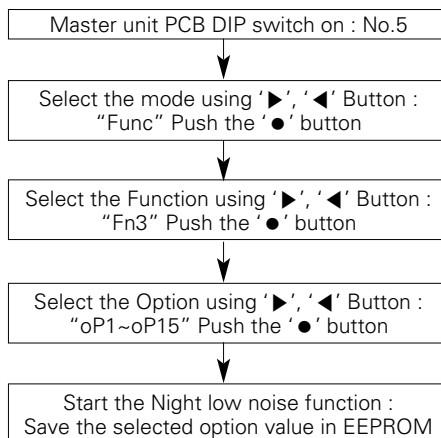

Time Settings

Step	Judgement Time(Hr)	Operation Time(Hr)
oP1	8	9
oP2	6.5	10.5
oP3	5	12
oP4	8	9
oP5	6.5	10.5
oP6	5	12
oP7	8	9
oP8	6.5	10.5
oP9	5	12
oP10	continuous operation	
oP11	continuous operation	
oP12	continuous operation	
oP13	6.5	10.5
oP14	6.5	10.5
oP15	6.5	10.5

CAUTION

- Request installer to set the function during installation.
- If ODU RPM changes, cooling capacity may go down.

Setting the ODU address

Mode setting method

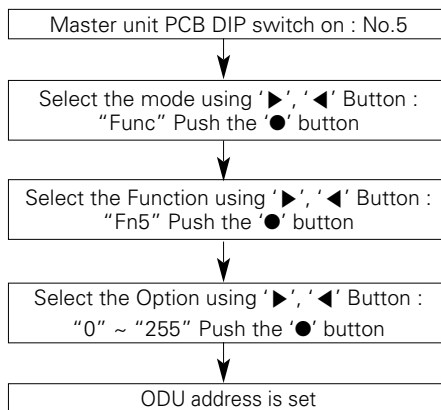

CAUTION

- Ask an authorized technician to setting a function.
- If use a function, first install a Central controller.

Snow removal & rapid defrost

Mode setting method

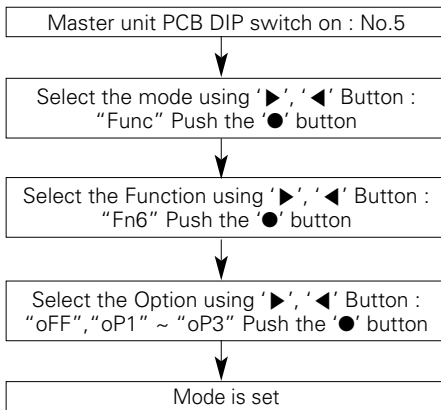

Mode setting

setting	Mode
oFF	Not setting
oP1	Snow removal mode
oP2	Rapid defrost mode
oP3	Snow removal mode. + Rapid defrost mode.

⚠ CAUTION

- Ask an authorized technician to setting a function.
- If do not use a function, set an off-mode.

Target pressure adjusting

Mode setting method

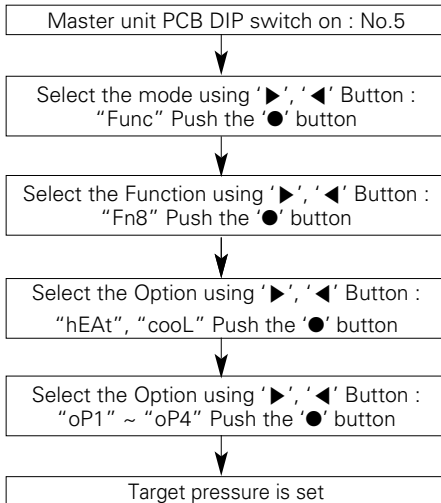

Setting

Mode	Purpose		Condensing temperature variation	Evaporating temperature variation
	Heat	Cool		
oP1	Increase capacity	Increase capacity	+2 °C	-3 °C
oP2	Decrease power consumption	Increase capacity	-2 °C	-1.5 °C
oP3	Decrease power consumption	Decrease power consumption	-4 °C	+2.5 °C
oP4	Decrease power consumption	Decrease power consumption	-6 °C	-4.5 °C

⚠ CAUTION

- Ask an authorized technician to setting a function.
- If do not use a function, set an off-mode.
- Change a power consumption or capacity.

Self-Diagnosis Function

Error Indicator

- This function indicates types of failure in self-diagnosis and occurrence of failure for air condition.
- Error mark is displayed on display window of indoor units and wired remote controller, and 7-segment LED of Compressor Module control board as shown in the table.
- If more than two troubles occur simultaneously, lower number of error code is first displayed.
- After error occurrence, if error is released, error LED is also released simultaneously.

Error Display

1st,2nd,3rd LED of 7-segment indicates error number, 4th LED indicates unit number.

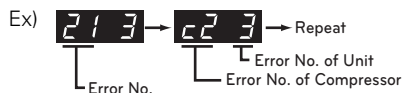

* Refer to the Indoor manual for some Indoor Error code.

Display			Title	Cause of Error	
Indoor unit related error	0	1	-	Air temperature sensor of indoor unit	Air temperature sensor of indoor unit is open or short
	0	2	-	Inlet pipe temperature sensor of indoor unit	Inlet pipe temperature sensor of indoor unit is open or short
	0	3	-	Communication error : wired remote controller ↔ indoor unit	Failing to receive wired remote controller signal in indoor unit PCB
	0	4	-	Drain pump	Malfunction of drain pump
	0	5	-	Communication error : MULTI V M ↔ indoor unit	Failing to receive MULTI V M signal in indoor unit PCB
	0	6	-	Outlet pipe temperature sensor of indoor unit	Outlet pipe temperature sensor of indoor unit is open or short
	0	9	-	Indoor EEPROM Error	In case when the serial number marked on EEPROM of Indoor unit is 0 or FFFFFF
	1	0	-	Poor fan motor operation	Disconnecting the fan motor connector/Failure of indoor fan motor lock
MULTI V M related error	2	1	1	MULTI V M Inverter Compressor IPM Fault	MULTI V M Inverter Compressor Drive IPM Fault
	2	2	1	Inverter Board Input Over Current(RMS) of MULTI V M	MULTI V M Inverter Board Input Current excess (RMS)
	2	3	1	MULTI V M Inverter Compressor DC link Low Voltage	DC charging is not performed at MULTI V M after starting relay turn on.
	2	4	1	MULTI V M High Pressure Switch	System is turned off by MULTI V M high pressure switch.
	2	5	1	MULTI V M Input Voltage High/ Low Voltage	MULTI V M input voltage is over 487V or below 270V
	2	6	1	MULTI V M Inverter Compressor Start Failure	The First Start Failure by MULTI V M Inverter Compressor Abnormality
	2	9	1	MULTI V M Inverter Compressor Over Current	MULTI V M Inverter Compressor Fault OR Drive Fault
	3	2	1	MULTI V M Inverter Compressor1 High Discharge Temperature	MULTI V M Inverter Compressor1 High Discharge Temperature
	3	4	1	High Pressure of MULTI V M	High Pressure of MULTI V M
	3	5	1	Low Pressure of MULTI V M	Low Pressure of MULTI V M
	3	6	1	MULTI V M Low Compression Ratio Limited	MULTI V M Low Compression Ratio Limited
	4	0	1	MULTI V M Inverter Compressor CT Sensor Fault	MULTI V M Inverter Compressor CT Sensor open or short
	4	1	1	MULTI V M Inverter Compressor1 Discharge Temperature Sensor Fault	MULTI V M Inverter Compressor Discharge Temperature Sensor open or short
	4	2	1	MULTI V M Low Pressure Sensor Fault	MULTI V M Low Pressure Sensor open or short
	4	3	1	MULTI V M High Pressure Sensor Fault	MULTI V M High Pressure Sensor open or short
	4	4	1	MULTI V M Air Temperature Sensor Fault	MULTI V M Air Temperature Sensor open or short
4	5	1	MULTI V M Heat Exchanger Temperature Sensor (Front side) Fault	MULTI V M Heat Exchanger Temperature Sensor(Front side) open or short	
4	6	1	MULTI V M Suction Temperature Sensor Fault	MULTI V M Suction Temperature Sensor open or short	

Display			Title	Cause of Error		
MULTI V M related error	5	0	1	Omitting connection of R, S, T power of MULTI V M	Omitting connection of MULTI V M	
	5	1	1	Excessive capacity of indoor units	Excessive connection of indoor units compared to capacity of MULTI V M	
	5	2	1	Communication error : inverter PCB → Main PCB	Failing to receive inverter signal at main PCB of MULTI V M	
	5	3	1	Communication error : indoor unit → Main PCB of MULTI V M	Failing to receive indoor unit signal at main PCB of MULTI V M.	
	5	7	1	Communication error : Main PCB → inverter PCB	Failing to receive signal main PCB at inverter PCB of MULTI V M	
	6	0	1	Inverter PCB EEPROM Error of Master MULTI V M	Access Error of Inverter PCB of MULTI V M	
	6	2	1	MULTI V M Inverter Heatsink High Temperature	System is turned off by MULTI V M Inverter Heatsink High Temperature	
	6	5	1	MULTI V M Inverter Heatsink Temperature Sensor Fault	MULTI V M Inverter Heatsink Temperature Sensor open or short	
	6	7	1	MULTI V M Fan Lock	Restriction of MULTI V M	
	7	1	1	Converter CT Sensor Error of MULTI V M	Converter CT Sensor open or short of MULTI V M	
	8	6	1	MULTI V M Main PCB EEPROM Error	Communication Fail Between MULTI V M Main MICOM and EEPROM or omitting EEPROM	
	1	1	3	1	MULTI V M Liquid pipe Temperature Sensor Error	Liquid pipe temperature sensor of MULTI V M is open or short
	1	1	5	1	MULTI V M Subcooling Outlet Temperature Sensor Error	MULTI V M Subcooling Outlet Temperature Sensor Error
	1	5	1	1	Failure of operation mode conversion at MULTI V M MULTI V M	Failure of operation mode conversion at MULTI V M
	1	0	4	*	Communication Error Between Master MULTI V M and Other MULTI V M	Failing to receive Slave Unit signal at main PCB of Master MULTI V M
	1	0	5	*	Master MULTI V M Fan PCB Communication Error	Failing to receive fan signal at main PCB of Master unit.
	1	0	6	*	Master MULTI V M FAN IPM Fault Error	Instant Over Current at Master MULTI V M Fan IPM
	1	0	7	*	Master MULTI V M Fan DC Link Low Voltage Error	Master MULTI V M Fan DC Link Input Voltage is under 380V
	1	1	3	*	Master MULTI V M Liquid pipe Temperature Sensor Error	Liquid pipe temperature sensor of Master MULTI V M is open or short
	1	1	4	*	Master MULTI V M Subcooling Inlet Temperature Sensor Error	Master MULTI V M Subcooling Inlet Temperature Sensor Error
	1	1	5	*	Master MULTI V M Subcooling Outlet Temperature Sensor Error	Master MULTI V M Subcooling Outlet Temperature Sensor Error
	1	1	6	*	Master MULTI V M Oil Level Sensor Error	Oil Level Sensor of Master MULTI V M is open or short
	1	4	5	*	Master MULTI V M Main Board - External Board communication Error	Master MULTI V M Main Board - External Board communication Error
	1	5	1	*	Failure of operation mode conversion at Master MULTI V M	Failure of operation mode conversion at Master MULTI V M
	1	5	3	*	Master MULTI V M Heat Exchanger Temperature Sensor (upper part) Fault	Master MULTI V M Heat Exchanger Temperature Sensor (upper part) Fault
	1	5	4	*	Master MULTI V M Heat Exchanger Temperature Sensor (lower part) Fault	Master MULTI V M Heat Exchanger Temperature Sensor(lower part) open or short
	1	8	2	*	Master MULTI V M External Board Main-Sub Micom communication Error	Master MULTI V M Main Board Main-Sub Micom communication failed
	1	9	3	*	Master MULTI V M Fan Heatsink High Temperature	System is turned off by Master MULTI V M Fan Heatsink High Temperature
1	9	4	*	Master MULTI V M Fan Heatsink Temperature Sensor Fault	Master MULTI V M Fan Heatsink Temperature Sensor open or short	

CAUTION FOR REFRIGERANT LEAK

The installer and system specialist shall secure safety against leakage according to local regulations or standards. The following standards may be applicable if local regulations are not available.

Introduction

Though the R410A refrigerant is harmless and incombustible itself, the room to equip the air conditioner should be large to such an extent that the refrigerant gas will not exceed the limiting concentration even if the refrigerant gas leaks in the room.

Limiting concentration

Limiting concentration is the limit of Freon gas concentration where immediate measures can be taken without hurting human body when refrigerant leaks in the air. The limiting concentration shall be described in the unit of kg/m³ (Freon gas weight per unit air volume) for facilitating calculation.

Limiting concentration: 0.44kg/m³(R410A)

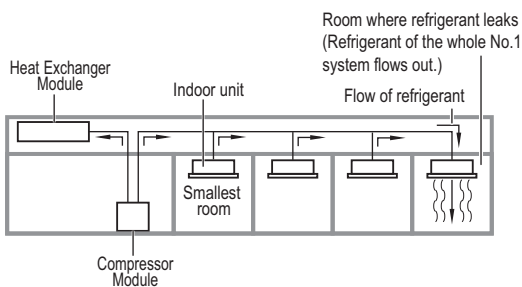

Checking procedure of limiting concentration

Check limiting concentration along following steps and take appropriate measure depending on the situation.

Calculate amount of all the replenished refrigerant (kg) per each refrigerant system.

Amount of replenished refrigerant per one MULTI V M system + Amount of additional replenished refrigerant depending on piping length or piping diameter at customer = Total amount of replenished refrigerant in refrigerant facility (kg)

Note: In case one refrigerant facility is divided into 2 or more refrigerant systems and each system is independent, amount of replenished refrigerant of each system shall be adopted.

Calculate minimum room capacity

Calculate room capacity by regarding a portion as one room or the smaller room.

- Without partition

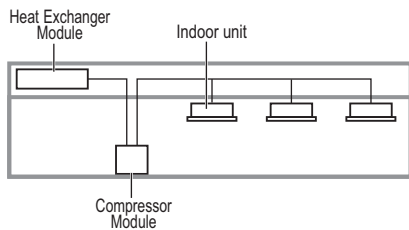

- With partition and with opening which serve as passage of air to adjoining room

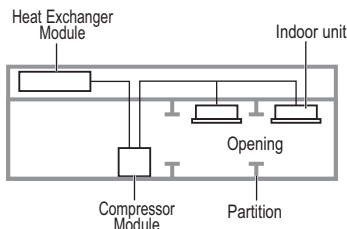

- With partition and without opening which serve as passage of air to adjoining room

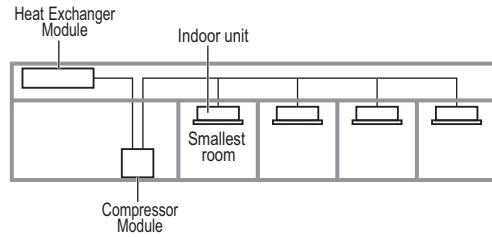

Calculate refrigerant concentration

$$\frac{\text{Total amount of replenished refrigerant in refrigerant facility (kg)}}{\text{Capacity of smallest room where indoor unit is installed (m}^3\text{)}} = \text{Refrigerant concentration (kg/m}^3\text{)} \quad (\text{R410A})$$

- In case the result of calculation exceeds the limiting concentration, perform the same calculations by shifting to the second smallest, and the third smallest rooms until at last the result is below the limiting concentration.

In case the concentration exceeds the limit

When the concentration exceeds the limit, change original plan or take one of the countermeasures shown below:

- Countermeasure 1
Provide opening for ventilation.
Provide 0.15% or more opening to floor space both above and below door, or provide opening without door.
- Countermeasure 2
Provide gas leak alarm linked with mechanical ventilator.
Reducing the MULTI V M refrigerant qty.

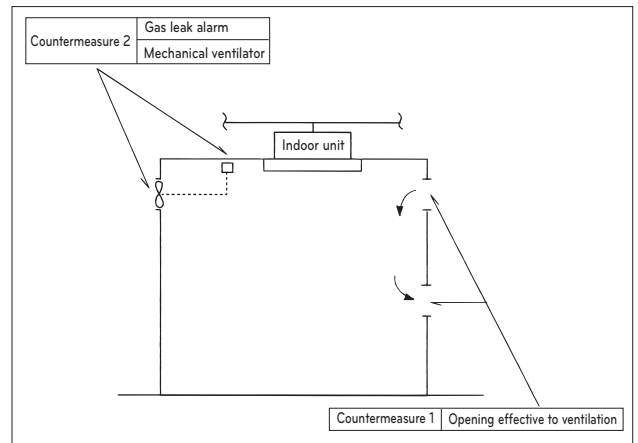

Pay a special attention to the place, such as a basement, etc. where refrigerant can stay, since refrigerant is heavier than air.

Model Designation

Product information

- Product Name : Air conditioner
- Model Name :

Model Name	ARU	N	050	L	M	S	0
No.	1	2	3	4	5	6	7

No.	Signification
1	MULTI V System MULTI V M using R410A
2	Combination of Inverter Type and Cooling Only or Heat Pump N: Inverter and H/P, V: Inverter and C/O
3	Total Cooling Capacity in Horse Power(HP) unit EX) 5HP → '050', 8HP → '080'
4	Electrical Ratings L : 380-415 V 3N~ 50 Hz / 380 V 3N~ 60 Hz G : 220-240 V~ 50 Hz / 220 V ~ 60Hz
5	Air discharge type S : Side Discharge T : Top Discharge N : Top Discharge Standard H/P(380V) L : Top Discharge special H/P M : Module type
6	Model Type S : Set C : Compressor Module E : Heat Exchanger Module
7	Serial number

- Additional information : Serial number is refer to the bar code on the product.

Airborne Noise Emission

The sound pressure of this product is below the 70dB.

** The noise level can vary depending on the site.

The figures quoted are emission level and are not necessarily safe working levels.

Whilst there is a correlation between the emission and exposure levels, this cannot be used reliably to determine whether or not further precautions are required.

Factor that influence the actual level of exposure of the workforce include the characteristics of the work room and the other sources of noise, i.e. the number of equipment and other adjacent processes and the length of time for which an operator exposed to the noise. Also, the permissible exposure level can vary from country to country.

This information, however, will enable the user of the equipment to make a better evaluation of the hazard and risk.



Manufacturer :

LG Electronics Inc.

84, Wanam-ro, Seongsan-gu, Changwon-si, Gyeongsangnam-do, KOREA

UK Importer : LG Electronics U.K. Ltd

Velocity 2, Brooklands Drive, Weybridge, KT13 0SL

Eco design requirement

- The information for Eco design is available on the following free access website.
<https://www.lg.com/global/support/cedoc/cedoc>