



LG

# LG Single Packaged-Type Air Conditioner

## *INSTALLATION MANUAL*

### IMPORTANT

- Please read this installation manual completely before installing the product.
- When the power device is damaged, replacement work shall be performed by authorized personnel only.
- Installation work must be performed in accordance with the national wiring standards by authorized personnel only.
- Please retain this installation manual for future reference after reading it thoroughly.

# TABLE OF CONTENTS

<b>Safety Precautions</b> .....	3
<b>Introduction</b> .....	8
Symbols Used in this Manual .....	8
Features .....	8
<b>Dimensional Data</b> .....	9
<b>Installation of Unit</b> .....	10
Inspection.....	10
Location and Recommendations .....	10
Ductwork .....	11
Condensate Drain Piping.....	11
Filter Installation .....	12
Installation of remote controller.....	13
Electrical Wiring .....	15
Control Wiring .....	16
Start-Up Pre-Start Quick Check List.....	18
Test Mode Procedure.....	19
Trial Run Mode.....	21
Group Control .....	21
Evaporator Fan Adjustment .....	22
Starting the Unit.....	23
Final Installation Checklist and Maintenance.....	24

# Safety Precautions

To prevent injury to the user or other people and property damage, the following instructions must be followed.

- Be sure to read before installing the air conditioner.
- Be sure to observe the cautions specified here as they include important items related to safety.
- Incorrect operation due to ignoring instruction will cause harm or damage. The seriousness is classified by the following indications.

**⚠ WARNING** This symbol indicates the possibility of death or serious injury.

**⚠ CAUTION** This symbol indicates the possibility of injury or damage to properties only.

- Meanings of symbols used in this manual are as shown below.



**Be sure not to do.**



**Be sure to follow the instruction.**

## ⚠ WARNING

### ■ Installation

**Do not use a defective or underrated circuit breaker. Use this appliance on a dedicated circuit.**

- There is risk of fire or electric shock.

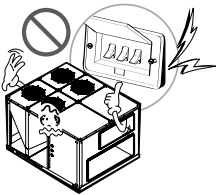

**For electrical work, contact the dealer, seller, a qualified electrician, or an Authorized Service Center.**

- Do not disassemble or repair the product. There is risk of fire or electric shock.

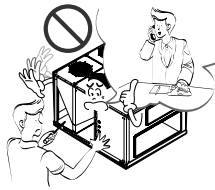

**Always ground the product.**

- There is risk of fire or electric shock.

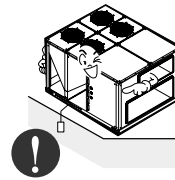

**Install the panel and the cover of control box securely.**

- There is risk of fire or electric shock.

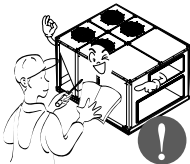

**Always install a dedicated circuit breaker.**

- Improper wiring or installation may cause fire or electric shock

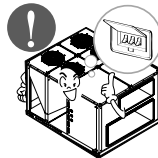

**Use the correctly rated breaker or fuse.**

- There is risk of fire or electric shock.

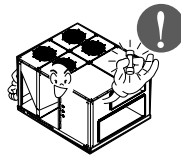

**Use the specified wires to connect the unit.**

- There is risk of fire or electric shock.

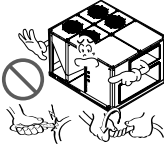

**Do not install, remove, or re-install the unit by yourself (customer).**

- There is risk of fire, electric shock, explosion, or injury.

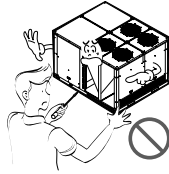

**Be cautious when unpacking and installing the product.**

- Sharp edges could cause injury. Be especially careful of the case edges and the fins on the condenser and evaporator.

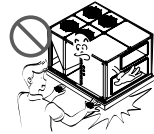

**For installation, always contact the dealer or an Authorized Service Center.**

- There is risk of fire, electric shock, explosion, or injury.



**Do not install the product on a defective installation stand.**

- It may cause injury, accident, or damage to the product.



**Be sure the installation area does not deteriorate with age.**

- If the base collapses, the air conditioner could fall with it, causing property damage, product failure, and personal injury.

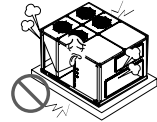

## ■ Operation

**Do not let the air conditioner run for a long time when the humidity is very high and a door or a window is left open.**

- Moisture may condense and wet or damage furniture.

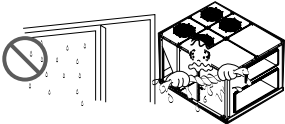

**Take care to ensure that power cable could not be pulled out or damaged during operation.**

- There is risk of fire or electric shock.



**Do not place anything on the power cable.**

- There is risk of fire or electric shock.

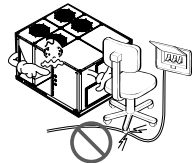

**Do not plug or unplug the power supply plug during operation.**

- There is risk of fire or electric shock.

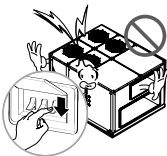

**Do not touch (operate) the product with wet hands.**

- There is risk of fire or electrical shock.



**Do not place a heater or other appliances near the power cable.**

- There is risk of fire and electric shock.

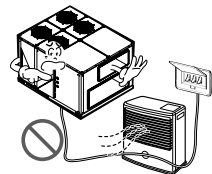

**Do not allow water to run into electric parts.**

- It may cause There is risk of fire, failure of the product, or electric shock.

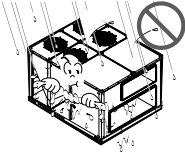

**Do not store or use flammable gas or combustibles near the product.**

- There is risk of fire or failure of product.

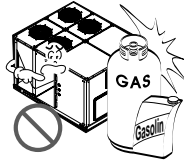

**Do not use the product in a tightly closed space for a long time.**

- Oxygen deficiency could occur.

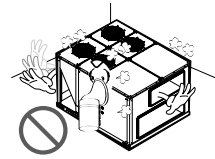

**When flammable gas leaks, turn off the gas and open a window for ventilation before turn the product on.**

- Do not use the telephone or turn switches on or off. There is risk of explosion or fire

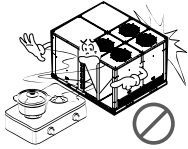

**If strange sounds, or small or smoke comes from product. Turn the breaker off or disconnect the power supply cable.**

- There is risk of electric shock or fire.



**Stop operation and close the window in storm or hurricane. If possible, remove the product from the window before the hurricane arrives.**

- There is risk of property damage, failure of product, or electric shock.

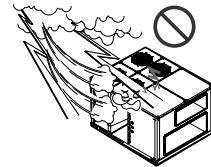

**Do not open the panel of the product during operation. (Do not touch the electrostatic filter, if the unit is so equipped.)**

- There is risk of physical injury, electric shock, or product failure.

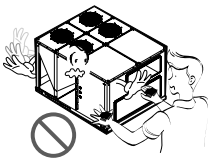

**When the product is soaked (flooded or submerged), contact an Authorized Service Center.**

- There is risk of fire or electric shock.

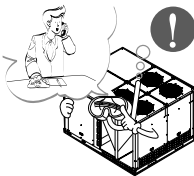

**Be cautious that water could not enter the product.**

- There is risk of fire, electric shock, or product damage.

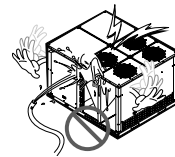

**Ventilate the product from time to time when operating it together with a stove, etc.**

- There is risk of fire or electric shock.

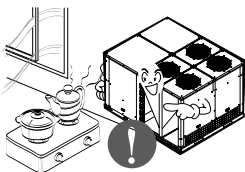

**Turn the main power off when cleaning or maintaining the product.**

- There is risk of electric shock.

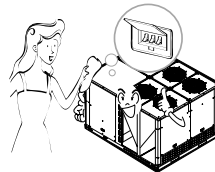

When the product is not be used for a long time, disconnect the power supply plug or turn off the breaker.

- There is risk of product damage or failure, or unintended operation.

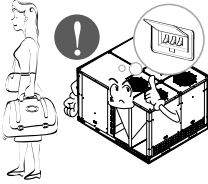

Take care to ensure that nobody could step on or fall onto the unit.

- This could result in personal injury and product damage.



## CAUTION

### Installation

Always check for gas (refrigerant) pressure after installation or repair of product.

- Low refrigerant levels may cause failure of product.

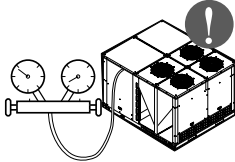

Install the drain hose to ensure that water is drained away properly.

- A bad connection may cause water leakage.

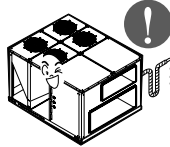

Keep level even when installing the product.

- To avoid vibration or water leakage.

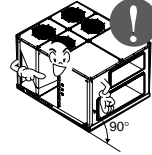

Do not install the product where the noise or hot air from the outdoor unit could damage the neighborhoods.

- It may cause a problem for your neighbors.

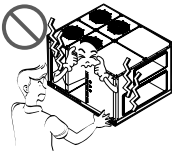

Don't use people to lift and transport the product.

- Avoid personal injury.

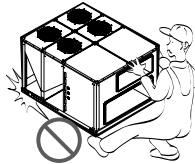

Do not install the product where it will be exposed to sea wind (salt spray) directly.

- It may cause corrosion on the product. Corrosion, particularly on the condenser and evaporator fins, could cause product malfunction or inefficient operation.

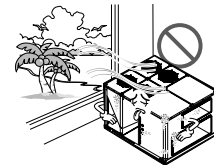

Having perfect vacuum process in the factory, our units don't have drier but have filter in the refrigerant circuit.

In case of recharging R-22 gas in the field,

**"DRIER" must be installed on the liquid** line which is connected from discharge part of condenser to intake part of evaporator. Because the refrigerant circuit is capable of containing water with imperfect vacuum.

## ■ Operation

**Do not expose the skin directly to cool air for long periods of time. (Don't sit in the draft.)**

- This could harm to your health.

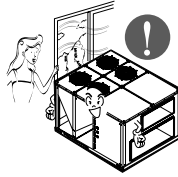

**Do not use the product for special purposes, such as preserving foods, works of art, etc. It is a consumer air conditioner, not a precision refrigeration system.**

- There is risk of damage or loss of property.

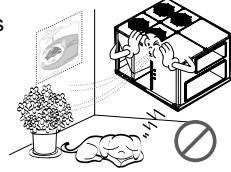

**Do not block the inlet or outlet of air flow.**

- It may cause product failure.

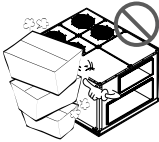

**Use a soft cloth to clean. Do not use harsh detergents, solvents, etc.**

- There is risk of fire, electric shock, or damage to the plastic parts of the product.

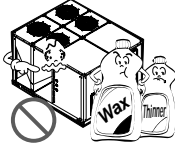

**Do not touch the metal parts of the product when removing the air filter. They are very sharp!**

- There is risk of personal injury.

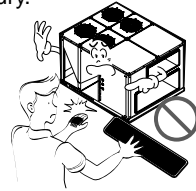

**Do not step on or put anything on the product. (outdoor units)**

- There is risk of personal injury and failure of product.

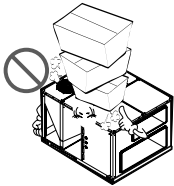

**Always insert the filter securely. Clean the filter every four weeks or more often if necessary.**

- A dirty filter reduces the efficiency of the air conditioner and could cause product malfunction or damage.

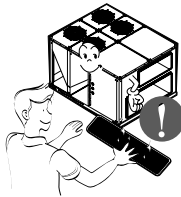

**Do not insert hands or other objects through the air inlet or outlet while the product is operated.**

- There are sharp and moving parts that could cause personal injury.

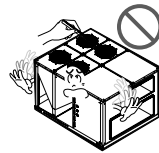

**Do not drink the water drained from the product.**

- It is not sanitary and could cause serious health issues.

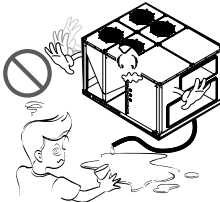

**Use a firm stool or ladder when cleaning or maintaining the product.**

- Be careful and avoid personal injury.

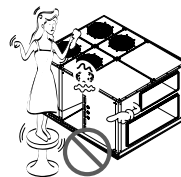

# Introduction

## Symbols Used in this Manual



This symbol alerts you to the risk of electric shock.



This symbol alerts you to hazards that could cause harm to the air conditioner.

**NOTICE**

This symbol indicates special notes.

## Features

### Front View

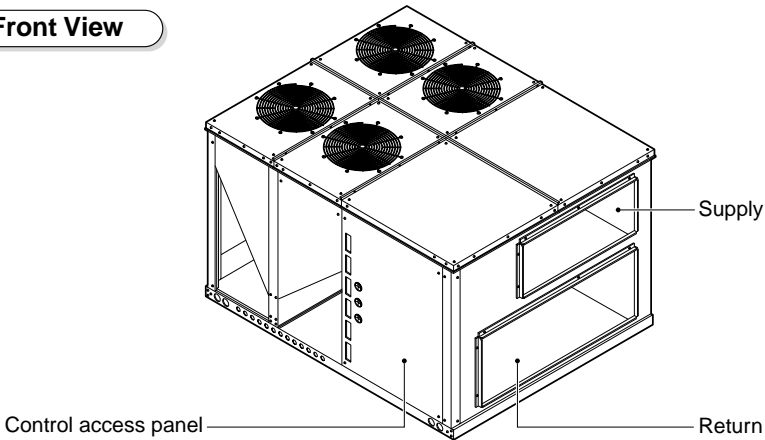

### Rear View

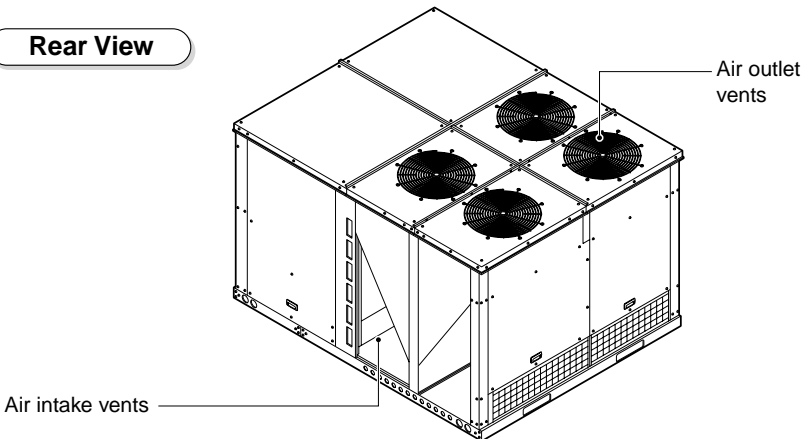



# Dimensional Data

Single packaged cooling unit are designed for outdoor mounting with vertical condenser discharge. They can be located either at ground level or on roof.

Each unit contains an operating charge of Refrigerant 22 as shipped.

## UNIT Dimensions (Figure 1A)

Unit: inch(mm)

UNITS	30RT
A	67 $\frac{11}{16}$ (1720)
B	86 $\frac{10}{16}$ (2200)
C	105 $\frac{13}{16}$ (2688)
D	42 $\frac{13}{16}$ (1087)
E	26 $\frac{12}{16}$ (680)
F	31 $\frac{8}{16}$ (800)
G	36 $\frac{4}{16}$ (920)

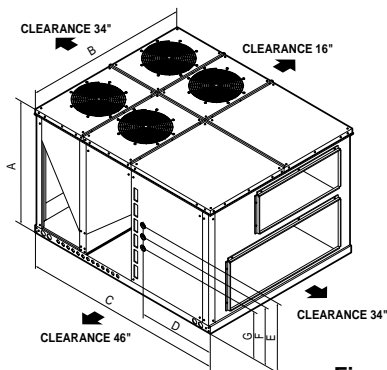

Figure 1A

## HORIZONTAL FLOW APPLICATION (Figure 1B)

Unit: inch(mm)

UNITS	30RT
A	49 $\frac{17}{16}$ (1255)
B	7 $\frac{9}{16}$ (192)
C	22 $\frac{1}{16}$ (561)
D	4 $\frac{6}{16}$ (111)
E	34 $\frac{13}{16}$ (885)
F	12/16 (19)
G	3 $\frac{2}{16}$ (80)
H	4 $\frac{8}{16}$ (115)
I	77 $\frac{7}{16}$ (1967)

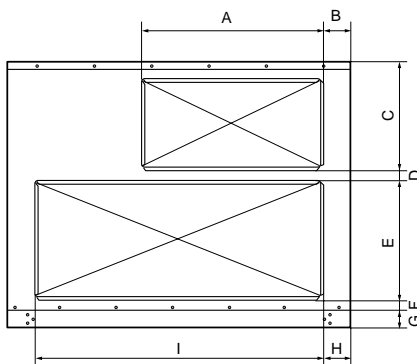

Figure 1B

# Installation of Unit

## Inspection

- 1) Check for damage after unit is unloaded. Report promptly, to the carrier, any damage found to unit. Do not drop unit.
- 2) Check the unit nameplate to determine if the unit voltage is correct for the application. Determine if adequate electrical power is available. Refer to the application specifications.
- 3) Check to be sure the refrigerant charge has been retained during shipment. Access to 1/4" flare pressure taps may be gained by removing compressor compartment access panel.

## Location and Recommendations

### 1) Unit Support

If unit is to be roof mounted check building codes for weight distribution requirements.

### 2) Location and Clearances

Installation of unit should conform to local building codes and the National Electrical Code.

Select a location that will permit unobstructed airflow into the condenser coil and away from the fan discharge and permit unobstructed service access into the compressor compartment. Suggested airflow clearances and service clearances are given in Figure 1.

### 3) Placing and Rigging

Rig the unit using either belt or cable slings. The sling eyelet must be placed through the lifting holes in the base rail of the unit. The point where the slings meet the lifting eyelet should be at least 6 feet above the unit. Use spreader bars to prevent excessive pressure on the top of the unit during lifting.

**NOTICE** : The use of "spreader bars" is required when hoisting the unit (prevents damage to sides and top). Top crating can be used as spreader bars.

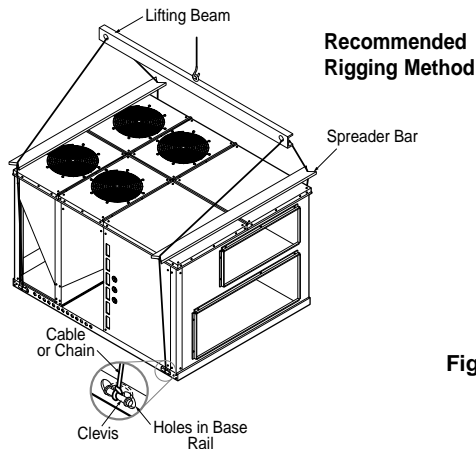

Figure 2

### 4) Roof Mounted Units

On new roofs, the curb should be welded directly to the roof deck. For existing construction, nailers must be installed under the curb if welding is not possible. Be sure attach the downflow ductwork to the curb before setting unit in place.

When installing the unit, it must be level to insure proper condensate flow from the unit drain pan.

### 5) Slab Mount

"For ground level installation, the unit base should be adequately supported and hold the unit near level. The installation must meet the guidelines set forth in local codes."

## Ductwork

### 1. Ductwork construction guidelines

Connections to the unit should be made with three-inch canvas connectors to minimize noise and vibration transmission.

Elbows with turning vanes or splitters are recommended to minimize air noise and resistance.

The first elbow in the ductwork leaving the unit should be no closer than three times blower diameter to avoid turbulence and back pressure.

### 2. Attaching Horizontal Ductwork to the Unit

All conditioned air ductwork should be insulated to minimize heating and cooling duct losses. Use minimum of 2" of insulation with a vapor barrier. The outside ductwork must be weather proofed between the unit and the building.

When attaching ductwork to a horizontal unit, provide a flexible water tight connection to prevent noise transmission from the unit to the ducts. The flexible connection **must** be indoors and molded out of heavy canvas.

**NOTICE** : Do not draw the canvas taut between the solid ducts.

## Condensate Drain Piping

A 3/4 inch male condensate drain connection is located on the corner of the unit next to the evaporator section access panel. A trap should be installed and filled with water before starting the unit to avoid air from being drawn through. Follow local codes and standard piping practices when running the drain line. Pitch the line downward, away from the unit, and avoid long horizontal runs. See Figure 3.

Do not use reducing fittings in the drain lines.

The condensate drain must be:

1. Made of 3/4" pipe size.
2. Pitched 1/4" per foot to provide free drainage to convenient drain system.
3. Trapped
4. Must not be connected to closed drain system.

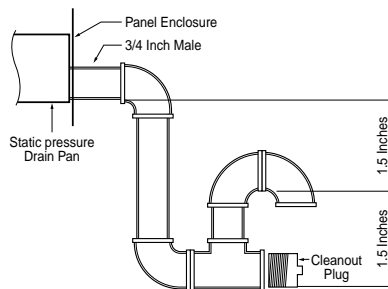

Figure 3

## Filter Installation

**This Unit Filters are anti-bacteria and washable type.**

Access to the filters is made by removing the evaporator fan access panel. Each unit ships with free filters, as determined by unit size.

On the filter access panel, "FILTER ACCESS PANEL" label is attached.

**NOTICE** : Do not operate unit without filters in place.

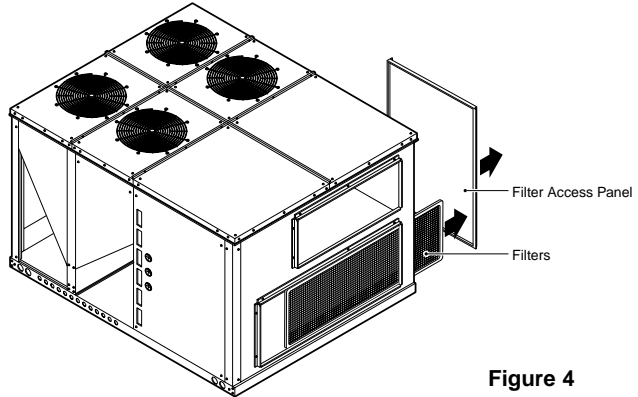

Figure 4

## Installation of Remote Controller

Install the remote control box and cord correctly.

### POINT OF REMOTE CONTROLLER INSTALLATION

- Although the room temperature sensor is in the indoor unit, the remote control box should be installed in such places away from direct sunlight and high humidity.

#### INSTALLATION OF THE REMOTE CONTROL BOX

- Select places that is not splashed by water.
- Select control position after receiving customer approval.
- The room temperature sensor of the thermostat for temperature control is built in the indoor unit.
- This remote controller equipped with liquid crystal display. If this position is higher or lower, display is difficult to see. (The standard height is 1.2~1.5m high)

#### ROUTING OF THE REMOTE CONTROL CORD

- Keep the remote control cord away from the refrigerant piping and the drain piping.
- To protect the remote control cord from electrical noise, place the cord at least 5cm away from other power cables. (Audio equipment, Television set, etc)
- If the remote control cord is secured to a wall, provide a trap at the top of the cord to prevent water droplets from running.

### ELECTRICAL WIRING TO THE INDOOR UNIT

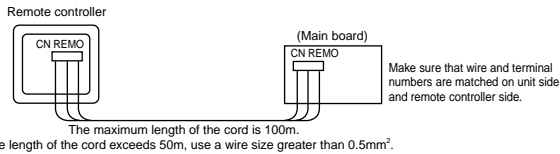

### DISASSEMBLING OF THE REMOTE CONTROLLER

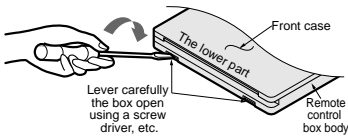

### WHEN THE REMOTE CONTROL BOX IS INSTALLED WITH THE CORD EXPOSED.

#### PROCEDURE OF INSTALLATION

1. Fix the under plate on the wall by self tapping screws (accessory).
2. Make a slit (Part A) at the top side of the remote control box by nipper.
3. Route the cord as shown in the following figure. In this case, push the cord into the around of case (Part B).
4. Hook the remote control unit on the under plate.

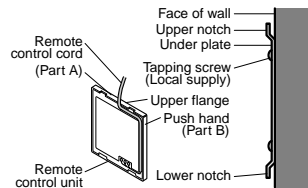

### WHEN THE REMOTE CONTROL BOX IS INSTALLED WITH THE CORD BURIED.

#### PROCEDURE OF INSTALLATION

1. Fix the under plate on the switch box by screws (Local supply). In this case, fit the under plate on the wall, and be careful of deformation.
2. Receive the remote control cord in the switch box.
3. Hook the remote control unit on the under plate.

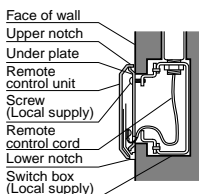

#### FIXING OF REMOTE CONTROL CORD

1. Fix the cord clamps on the wall by  $\phi 3$  tapping screws (Local supply).
2. Fix the remote control cord.

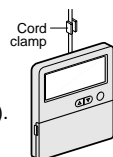

### WIRED REMOTE CONTROLLER INSTALLATION

- Since the room temperature sensor is in the remote controller, the remote controller box should be installed in a place away from direct sunlight, high humidity and direct supply of cold air to maintain proper space temperature.

Install the remote controller about 5ft(1.5m) above the floor in an area with good air circulation at an average temperature.

#### Do not install the remote controller where it can be affected by:

- Drafts, or dead spots behind doors and in corners.
- Hot or cold air from ducts.
- Radiant heat from sun or appliances.
- Concealed pipes and chimneys.
- Uncontrolled areas such as an outside wall behind the remote controller.
- This remote controller is equipped with a seven segment LED. display. For proper display of the remote controller LED's, the remote controller should be installed properly as shown in Fig.5.

(The standard height is 1.2~1.5 m from floor level.)

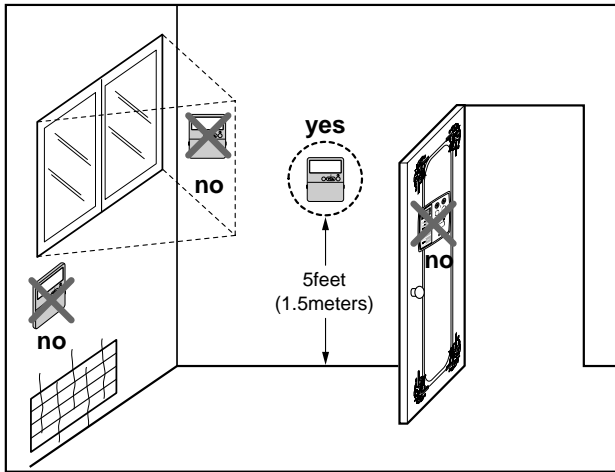

Figure 5 Typical locations for remote controller

## Electrical Wiring

Check the unit nameplate for the required supply voltage. Determine if adequate electrical power is available. Refer to application specifications.

Electrical wiring and grounding must be installed in accordance with local codes and with the National Electric code Latest Revision.

### Electrical Power

It is important that proper electrical power is available for the unit. Voltage variation should remain within the limits stamped on the nameplate.

### Disconnect Switch

Provide an approved weatherproof disconnect either on the side of unit or within close proximity.

### Over Current Protection

The branch circuit feeding the unit must be protected as shown on the unit rating plate.

### Power Wiring

The power supply lines must be run in approved conduit to the disconnect, and in the unit control box. Provide strain relief for all conduit with suitable connectors. Provide flexible conduit supports whenever vibration transmission may cause a noise problem within the building structure.

### Power Entry Guide

**NOTICE** : Holes are provided for low-voltage and high-voltage wiring. It is not necessary to punch any new holes in either the interior or exterior unit panels. If new holes are punched, performance will be adversely affected unless they are resealed to be both air- and watertight.

**Typical Field wiring Diagram (Figure 6A)  
Low Voltage Field Wiring (Figure 6A)  
(For three phase electricity product)**

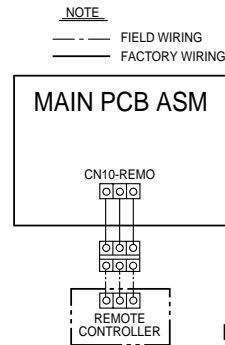

- See wiring diagram for details.

**Figure 6A**

**High Voltage Field Wiring Diagram (Figure 6C)  
(For three phase electricity product)**

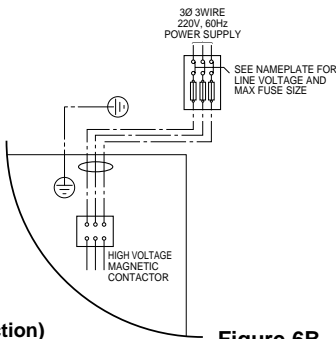

( $\Delta$  Connection)

**Figure 6B**

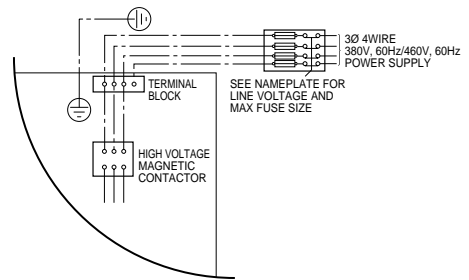

(Y Connection)

**Figure 6C**

Provide flexible conduit supports whenever vibration transmission may cause a noise problem within the building structure.

See Figure 6C for high voltage wiring connections. Insure all connections are made tight.

**NOTICE** : For branch circuit wiring (main power supply to unit disconnect), Wire size for the length of run should be determined using the circuit ampacity found on the unit nameplate and the N.E.C..

For more than 3 conductors in a raceway or cable, see the N.E.C. for de-rating the ampacity of each conductor.

**GROUNDING: THE UNIT MUST BE ELECTRICALLY GROUNDED IN ACCORDANCE WITH LOCAL CODES AND THE NATIONAL ELECTRICAL CODE.**

**Control Wiring**

Remote controller conductors are standard thermostat wire 22 to 14 ga.

Recommended wire sizes and lengths for installing the remote controller are provided in the table on page 17. Resistance of 2 1/2 ohms per conductor can cause deviation in the accuracy of the control.



## Field Installed DC Control Wiring

Before installing the connecting wiring between the components utilizing a DC analog output/input signal and the unit, refer to the following table for conductor sizing guidelines and;

- 1) Use standard copper conductor thermostat wire unless otherwise specified.
- 2) Ensure that the wiring between the controls and the unit's termination point does not exceed two and a half (2 1/2) ohms/conductor for the length of the run.
- 3) Refer to Figure 5 for the electrical access locations provided on the unit.
- 4) Do not run the electrical wires transporting Sensor DC signals in or around AC wires.

**NOTICE** : Resistance in excess of 2.5 ohms per conductor can cause deviations in the accuracy of the controls

### DC Conductors

Distance from Unit to Control	Recommended Wire Size	Remark
000 - 150 feet	22 gauge	Shielded wire recommended
151 - 240 feet	20 gauge	
241 - 385 feet	18 gauge	
386 - 610 feet	16 gauge	
611 - 970 feet	14 gauge	

## Emergency Shut Down

For Emergency Shut Down, remove the jumper between 1 and 2 and install normally closed contacts (Open at Fault Condition). Immediate shut down will occur and the MAIN CONTROLLER will be disabled.

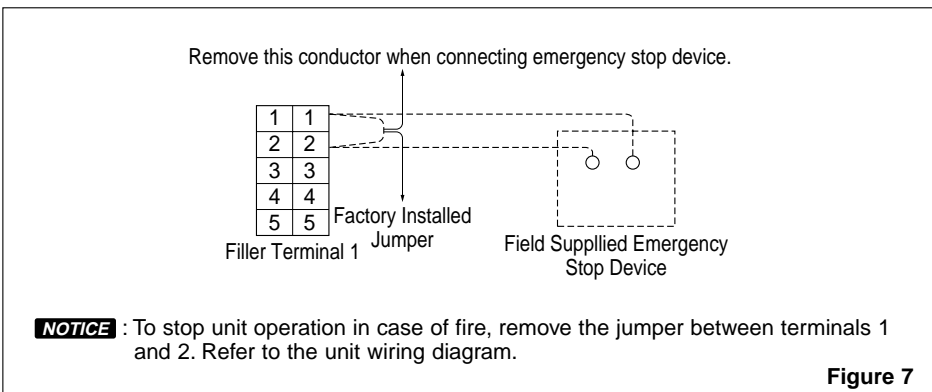

**NOTICE** : After completion of wiring, check all electrical connections, including factory wiring within the unit, and ensure all connections are tight. Replace and secure all electrical box covers and access doors before leaving unit or connecting power to circuit supplying unit.

## Start-Up Pre-Start Quick Check List

• Is unit level and located with proper clearances?	→ See Figure 1.
• Is the duct work correctly sized, run, taped, insulated and weather proofed with proper unit arrangement?	→ See duct work installation
• Is condensate line properly sized, run trapped and pitched?	
• Is the filter of the correct size, clean and in place?	
• Is the wiring properly sized and run in according to the unit wiring diagram?	
• Are all wiring connections tight including those in unit and compressor electrical boxes?	
• Has the unit been properly grounded and fused with the recommended fuse size?	
• Is the remote controller correctly wired and in a good location?	
• Have the air conditioning systems been checked at the service ports for charge and leak tested if necessary?	
• Does the condenser fan and indoor fan turn freely without rubbing and are they tight on the shafts?	
• Visually inspect the unit to ensure that the airflow required for the condenser coil is not obstructed from the unit.	
• Inspect the control panel wiring to verify that all electrical connections are tight, and that wire insulation is intact.	
• Is the indoor fan and rotation correct?	
• Has the indoor fan speed been determined and the proper speed been set?	→ See air flow performance data
• Has all work been done in accordance with applicable local and national codes?	
• Are all covers and access panels in place to prevent air loss and safety hazards?	

 **WARNING: Bodily injury can result from high voltage electrical components. If operating checks must be performed with the unit operating, it is the technician's responsibility to recognize these hazards and proceed safely. Failure to do so could result in severe personal injury or death due to electrical shock or contact with moving parts.**

### Power-up Initialization

The "initialization" by the MAIN CONTROLLER occurs each time the system is powered-up. the MAIN CONTROLLER performs internal self-diagnostics checks, which include identifying the equipment components of its system, and the configuring of itself to that system. It also checks itself to be sure it is functioning correctly.

## Test Mode Procedure

Operating the unit from the roof using the test mode.



**WARNING:** When operating the unit the test mode, the evaporator access panel and the control box cover, must be closed. Failure to ensure that the evaporator access panel and control box cover is in place could result in severe personal injury or death.

### Step test Mode

The step test mode is initiated by pressing test key (tact switch located on MAIN CONTROLLER).

When the test mode is initiated, the system will begin the first test step, and turn on the indoor fan. (See test mode table.)

To continue to the next step, repress the test key.

As you repeat to press the Test key, the unit will move through the steps according to the tabel.

The Test Mode is performed only when the unit is in "STOP" state.

Any operating signal from remote controller or thermostat can interrupt "Test Mode" and operate the unit to the signal.

To quit Test Mode, cycle the unit power at the unit disconnect, or repeat to press the Test key until the unit stop.

### Test Key Location

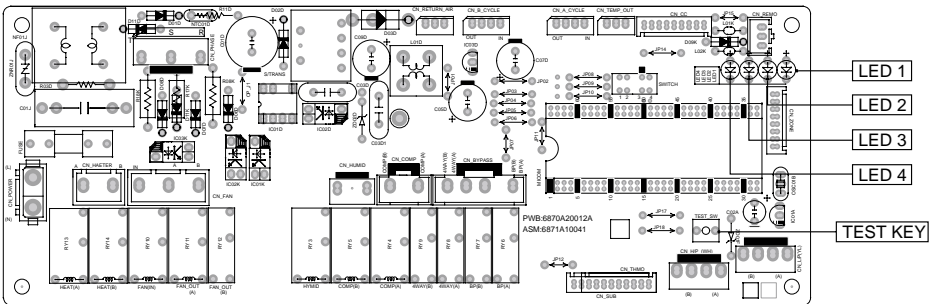

### Test Mode Table

Test key is available when the power is off

★: ON  
☆: OFF

STEP	INDOOR FAN	*OUTDOOR FAN 1	*OUTDOOR FAN 2	COMP 1	* COMP 2	* HEATER 1	* HEATER 2	* HUMIDIFIER	*4WAY VALVE 1	*4WAY VALVE 2	* B/pass	* B/pass
1	★	☆	☆	☆	☆	☆	☆	☆	☆	☆	☆	☆
2	★	★	☆	☆	☆	☆	☆	☆	☆	☆	☆	☆
3	★	★	★	☆	☆	☆	☆	☆	☆	☆	☆	☆
4	★	★	★	★	☆	☆	☆	☆	☆	☆	☆	☆
5	★	★	★	★	★	☆	☆	☆	☆	☆	☆	☆
6	★	☆	☆	☆	☆	★	☆	☆	☆	☆	☆	☆
7	★	☆	☆	☆	☆	★	★	☆	☆	☆	☆	☆
8	★	☆	☆	☆	☆	★	★	★	☆	☆	☆	☆
9	★	☆	☆	☆	☆	☆	☆	☆	★	☆	☆	☆
10	★	☆	☆	☆	☆	☆	☆	☆	★	★	☆	☆
11	★	☆	☆	☆	☆	☆	☆	☆	☆	☆	★	★
12	☆	☆	☆	☆	☆	☆	☆	☆	☆	☆	☆	☆

**NOTICE**

1. " \* " mark means that the function depends on unit model. In case the unit doesn't have that function or options, you can move on to next test step by pressing TEST KEY again.
2. Test mode is finished after pressing TEST KEY 12 times and then you can control with remote controller.
3. One more pressing of TEST KEY after pressing 12 times return test mode to step 1. (NOTICE)

### Error Mode

- When unit has an error, LCD on the remote controller shows Error Mode that indicate cause of error.
- To reset unit, turn off and on circuit breaker.

Error Mode	Cause of Error
CH 01	OPEN/SHORT of room temp. sensor
CH 02	OPEN/SHORT of indoor pipe temp.
CH 03	Communication Error
CH 04	OPEN/SHORT of outdoor pipe sensor
CH 05	OPEN/SHORT of outdoor room temp.
CH 16	Open of A_Cycle_Low Pressure Switch
CH 17	Open of B_Cycle_Low Pressure Switch
CH 18	Open of A_Cycle_High Pressure Switch
CH 19	Open of B_Cycle_High Pressure Switch
CH 21	Phase Reversal Error
CH 22	Phase loss

## Trial Run Mode

Operating the unit in the room without concerning about set temperature.

Pressing simultaneously 'Room Temperature Checking Button' and 'Hour Button' for 3 seconds regardless of room temperature setting, the unit operates in cooling mode for 18 minutes and stops.

To cancel Trial Run Mode, press one of Set Temperature, Timer set, Fan operation button.

Each time pressing 'Operation Mode Selection Button', dehumidification, Heating, Cooling mode operates sequentially.

E-Heater doesn't work during 'Trial Run Mode' but humidifier function is selectable.

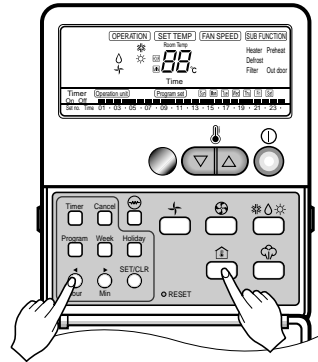

## Group Control

It operates maximum 16 Units by only one Wired Remote Controller, and each Unit starts sequentially to prevent overcurrent.

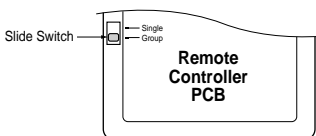
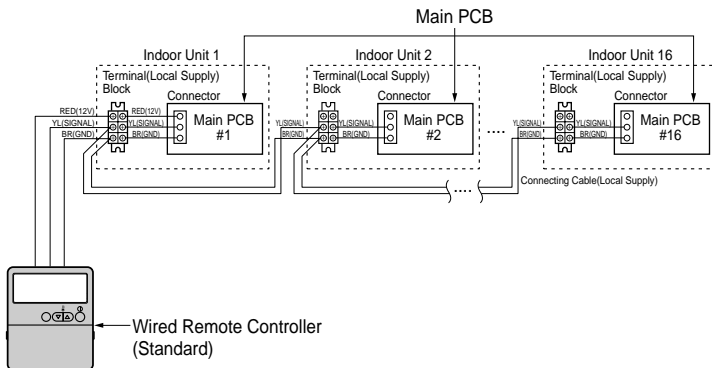

- Using the supplied Wired Remote Controller, wire them like above.
- Move slide switch to "Group" position.
- Ensure that the color of wire.

# Evaporator Fan Adjustment

Use the following procedure to determine the proper adjustment of the evaporator fan for a specific application.

1. Determine total system external static pressure (in inches water column) with accessories installed. to accomplish this:
  - 1) Obtain the design airflow rate and the design external static pressure drop through the distribution system. Your sales representative or the design engineer can provide you with these values.
  - 2) Using the table from unit Service Manual, add static pressure drop of the accessories installed on the unit.
  - 3) Add the total accessory static pressure drop (from step 1b) to the design external static pressure. The sum of these two values is the total system external static pressure.
2. Use the table(s) in the Service Manual to find the external static pressure (in inches water column) that most closely approximates total system external static pressure. Then locate the appropriate airflow rate (on cfm) for your unit. The value obtained represents the break horsepower for the evaporator fan motor and the fan RPM.

**NOTICE** : Fan Break Horsepower (BHP) listed in the Table is the percentage range of nameplate amperage the motors will safely work within, before an oversized motor is required.

The indoor fan speed is changed by opening or closing the adjustable motor sheave. See Figure 8.

### To Increase CFM

Loosen the pulley adjustment set screw and turn sheave clockwise.

### To Decrease CFM

Loosen the pulley adjustment set screw and turn sheave counterclockwise.

**NOTICE** : The actual external static pressure may varies from design ESP due to actual duct work installation.  
The required air flow should be respected to provide the design cooling capacity.

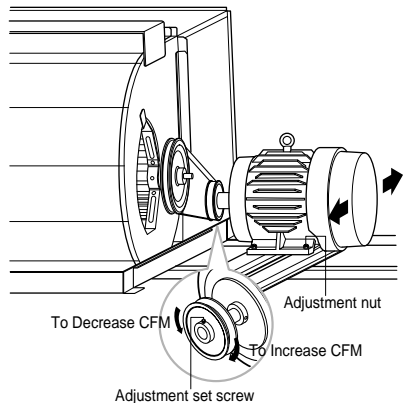

Figure 8A

### To Increase Belt Tension

- 1) Loosen adjustment nut(4places).
- 2) Pull motor back until belt is tight.
- 3) Tighten adjustment nut after belt has correct tension.

FORCE(F)	HEIGHT	REMARK
9~11 lbf	0.8 ~ 1.2(inch)	-

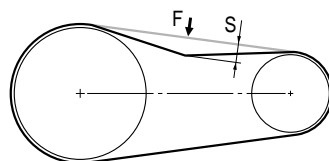

Figure 8B

## Starting the Unit

### Heating Mode

(If unit is equipped with electric heater.)

Check to ensure all grilles and registers are open and all unit access doors are closed before start-up.

Turn on unit main power supply.

Press the E/Heater operation button on the Remote controller.

Set the temperature approximately 5°C above room temperature.

### Cooling Mode

Verify that the unit airflow rate is adjusted according to information provided in "Determining Evaporator Fan Adjustment" section of this manual.

To start the unit in the cooling mode, close unit disconnect switch and set the operating mode to COOL and move the cooling setpoint approximately 5°C below room temperature. The condenser fan motor, compressor and evaporator fan motor should operate automatically. There will be a delay of up to 3 minutes before the unit will start in the cooling mode.

### Operating Pressures

After the unit has operated in the cooling mode for a short period of time, install pressure gauges on the gauge ports of the discharge and suction line valves.

**NOTICE** : Always route refrigerant hoses through the port hole provided and have compressor access panel in place.

Check the suction and discharge pressures and compare them to the normal operating pressures provided in the unit's Service Manual.

**NOTICE** : Do not use pressures from Service manual to determine the unit refrigerant charge. The correct charge is shown on the unit nameplate. To charge the system accurately, use superheat charging or weigh the charge.

### Voltage

With the compressor operating, check the line voltage at the unit. The voltage should be within the range shown on the unit nameplate. If low voltage is encountered, check the size and length of the supply line from the main disconnect to the unit. The line may be undersized for the length of the run.



**WARNING: Bodily injury can result from high voltage electrical components. If operating checks must be performed with the unit operating, it is the technician's responsibility to recognize these hazards and proceed safely. Failure to do so could result in severe personal injury or death due to electrical shock or contact with moving parts.**

## Final Installation Checklist and Maintenance

- Does unit run and operate as described in the "Sequence of Operation" in the unit Service Manual?
- Is the condenser fan and indoor blower operating correctly, with proper rotation and without undue noise?
- Are the compressors operating correctly and has the system been checked with a charging chart?
- Have voltage and running currents been checked to determine if it is within limits?
- Have the air discharge grilles been adjusted to balance the system?
- Has the ductwork been checked for air leaks and condensation?
- Has the indoor airflow been checked and adjusted if necessary?
- Has the unit been checked for tubing and sheet metal rattles and are there unusual noises to be checked?
- Are all covers and panels in place and properly fastened?
- Has the owner or maintenance personnel been given this manual, warranty, and been instructed on proper operation and maintenance?

### Routine Maintenance By Owner

You can do some of the periodic maintenance functions for your unit yourself; this includes cleaning air filters, cleaning unit cabinet, cleaning the condenser coil, and conducting a general unit inspection on a regular basis.



**WARNING: Before removing access panels to service unit, disconnect power supply. Failure to disconnect power before attempting any servicing can result in severe injury or death.**

### Air Filters

It is very important to keep the central duct system air filters clean. Be sure to inspect them at least once each month when the system is in constant operation. (In new buildings, check the filters every week for the first 4 weeks.)

These units have anti-fungus filter.

Permanent type filters can be cleaned by washing with a mild detergent and water. Ensure that the filters are thoroughly dry before reinstalling them in the unit (or duct system).



## Condenser coil

Unfiltered air circulates through the unit's condenser coil and can cause the coil's surface to become clogged with dust, dirt, etc.. To clean the coil, vertically (i.e., along the fins) stroke the coil surface with a soft bristled brush.

Keep all vegetation away from the condenser coil area.

## Maintenance Performed by Serviceman-Cooling Season

To keep your unit operating safely and efficiently, the manufacturer recommends that a qualified serviceman check the entire system at least once each year, or more frequently if conditions warrant. Your serviceman may examine these areas of your unit:

1. Filters	→ For cleaning
2. Motors and drive system components	
3. Condenser coils	→ For cleaning
4. Safety Controls	→ For mechanical cleaning
5. Electrical components and wiring	→ For possible replacement or connection tightness
6. Condensate drain	→ For cleaning
7. Inspect the unit duct connections to ensure they are physically sound and sealed to the unit casing.	
8. Inspect the unit mounting support to see that it is sound.	
9. Inspect the unit to ensure there is no obvious deterioration.	

## Maintenance Performed By Serviceman-Heating Season

Complete the unit inspections and service routines described below at the beginning of each heating season.



**CAUTION: To prevent injury or death due to electrical shock of contact with moving parts, lock unit disconnect switch in open position before servicing unit.**

**To prevent an explosion and possible injury, death and equipment damage, do not store combustible materials, gasoline or other flammable vapors and liquids near the unit.**

Inspect the control panel wiring to verify that all electrical connections are tight and wire insulation is intact.



