

# CONVERTIBLE TYPE AIR CONDITIONERS INSTALLATION INSTRUCTIONS

- Please read this instruction manual completely before installing the product.
- When the power cord is to be replaced, replacement work shall be performed by authorized personnel only.
- Installation work must be performed in accordance with national wiring standards by authorized personnel only.

## Installation Parts Provided

- ① Installation Plate (2pcs)
- ② Washer Bolt (M8 × L25, 4pcs, type "A")
- ③ Floor Mount Bracket (1pcs)
- ④ Drain Hose, Insulated
- ⑤ Remocon Holder
- ⑥ Screw for Remocon Holder (type "B")
- ⑦ Drain Hose Hanger and screw

## The other Installation Parts Needed

- ⑧ Suspension Bolt
- ⑨ Bolts for Mount Bracket
- ⑩ Connecting Tube
  - Gas side :  $\varnothing 12.7/\varnothing 15.88$
  - Liquid side :  $\varnothing 6.35/\varnothing 9.52$
- ⑪ Connecting Cable
- ⑫ Drain Hose Extended

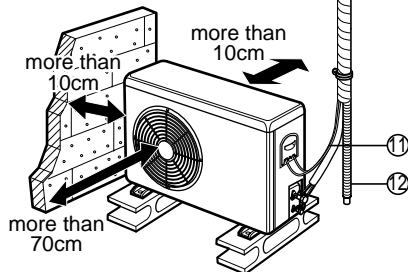
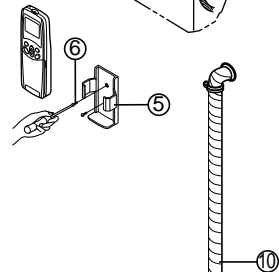
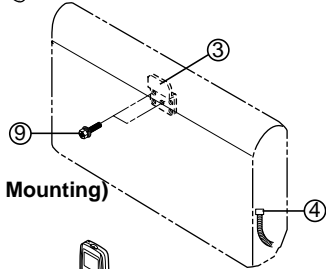
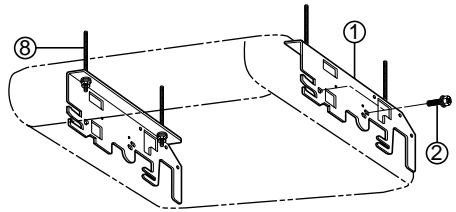



# OUT-LINE OF INSTALLATION

## 1. The following should be always observed for safety .....3

Installation works	Installation Parts	Required tools
<b>2. Installation of Indoor, Outdoor unit</b>		
1) Selection of the best location .....4 2) Indoor unit installation .....5 Installation on the ceiling ..5 Installation on the wall .....9 Installation on the floor ...11	<ul style="list-style-type: none"> <li>• Installation Plate</li> <li>• Four Type "A" screws</li> <li>• Connecting cable</li> </ul>	<ul style="list-style-type: none"> <li>• Level</li> <li>• Screw driver</li> <li>• Electric drill</li> <li>• Hole core drill (ø70mm)</li> </ul>
<b>3. Connecting Pipes to the Indoor Unit</b>		
1) Preparation of Piping .....12 2) Installation on the ceiling 13 3) Installation on the wall or floor.....14	<ul style="list-style-type: none"> <li>• Pipes: Gas side .....<math>1/2"</math>, <math>5/8"</math>                Liquid side .....<math>1/4"</math>, <math>3/8"</math></li> <li>• Insulated drain hose</li> <li>• Insulation materials</li> </ul>	<ul style="list-style-type: none"> <li>• Flaring Tools set</li> <li>• Specified Torque Wrenches                1.8kg-m ..... Liquid side piping                5.5kg-m ..... Gas side piping                Spanner ..... Half union..</li> </ul>
<b>4. Connecting Pipes to the Outdoor Unit</b>		
1) Connecting the pipes to the Outdoor Unit .....15	<ul style="list-style-type: none"> <li>• Additional Drain hose                (Outer Dia.....15.5mm)</li> </ul>	<ul style="list-style-type: none"> <li>• Specified Torque Wrenches                1.8kg-m ..... Liquid side piping                5.5kg-m ..... Gas side piping</li> </ul>
<b>5. Checking the Drainage .....15</b>		
<b>6. Connecting Cables between Indoor Unit and Outdoor Unit</b>		
		<ul style="list-style-type: none"> <li>• Hexagonal Wrench (4mm)</li> <li>• Gas-leak Detector</li> </ul>
<b>7. Air Purging of Pipes and Indoor Unit .....19</b>		
1) Connecting cables to the Indoor Unit .....16 2) Connecting cables to the Outdoor Unit .....17 3) Form the pipings.....18	<ul style="list-style-type: none"> <li>• Screw driver</li> </ul>	
<b>8. Test running</b>		
1) Connection of power supply. ....20 2) Evaluation of the performance .....20	<ul style="list-style-type: none"> <li>• Two type "B" screws</li> </ul>	<ul style="list-style-type: none"> <li>• Owner's Manual</li> <li>• Thermometer</li> </ul>

# 1. The following should always be observed for safety

- Please report to or take consent by the supply authority before connection to the system.
- Be sure to read "THE FOLLOWING SHOULD ALWAYS BE OBSERVED FOR SAFETY" before installing the air conditioner.
- Be sure to observe the cautions specified here as they include important items related to safety.
- The indications and meanings are as follows.

	<b>WARNING</b>	Could lead to death, serious injury, etc.
	<b>CAUTION</b>	Could lead to serious injury in particular environments when operated incorrectly.

- After reading this manual, be sure to keep it together with the instruction manual in a handy place on the customer's site.

## **WARNING**

<p><b>Do not install it yourself (customer).</b></p> <ul style="list-style-type: none"> <li>• Incomplete installation could cause injury due to fire, electric shock, the unit falling or a leakage of water. Consult the dealer from whom you purchased the unit or special installer.</li> </ul>	<p><b>Perform the installation securely referring to the installation manual.</b></p> <ul style="list-style-type: none"> <li>• Incomplete installation could cause a personal injury due to fire, electric shock, the unit falling or a leakage of water.</li> </ul>
<p><b>Install the unit securely in a place which can bear the weight of the unit.</b></p> <ul style="list-style-type: none"> <li>• When installed in an insufficient strong place, the unit may fall and result in serious problem.</li> </ul>	<p><b>Perform electrical work according to the installation manual and be sure to use an exclusive circuit.</b></p> <ul style="list-style-type: none"> <li>• If the capacity of the power circuit is insufficient or there is incomplete electrical work, it could result in a fire or an electric shock.</li> </ul>
<p><b>Use the specified wires to connect the indoor and outdoor units securely and attach the wires firmly to the terminal board connecting sections so the stress of the wires is not applied to the sections.</b></p> <ul style="list-style-type: none"> <li>• Incomplete connecting and fixing could cause fire.</li> </ul>	<p><b>Attach the electrical part cover to the indoor unit and the service panel to the outdoor unit securely.</b></p> <ul style="list-style-type: none"> <li>• Not being attached securely, it may cause electric problem or electric shock due to dust or water etc.</li> </ul>
<p><b>Check that the refrigerant gas due not leak after installation is completed.</b></p>	<p><b>Be sure to use the part provided or specified parts for the installation work.</b></p> <ul style="list-style-type: none"> <li>• The use of defective parts could cause an injury or leakage of water due to a fire, electric shock, the unit falling, etc.</li> </ul>

## **CAUTION**

<p><b>Perform the drainage/piping work securely according to the installation manual.</b></p> <ul style="list-style-type: none"> <li>• If there is a defect in the drainage/piping work, water could drop from the unit and household goods could be wet and damaged.</li> </ul>	<p><b>Do not install the unit in a place where an inflammable gas leaks.</b></p> <ul style="list-style-type: none"> <li>• If gas leaks and accumulates in the area surrounding the unit, it could cause an explosion.</li> </ul>
--	--

## 2. Installation of Indoor, Outdoor unit

### 1. Selection of the best location

#### 1) Indoor unit

- There should not be any heat source or steam near the unit.
- There should not be any obstacles to prevent the air circulation.
- A place where air circulation in the room will be good.
- A place where drainage can be easily obtained.
- A place where noise prevention is taken into consideration.
- Do not install the unit near the door way.
- Ensure the spaces indicated by arrows from the wall, ceiling, or other obstacles.

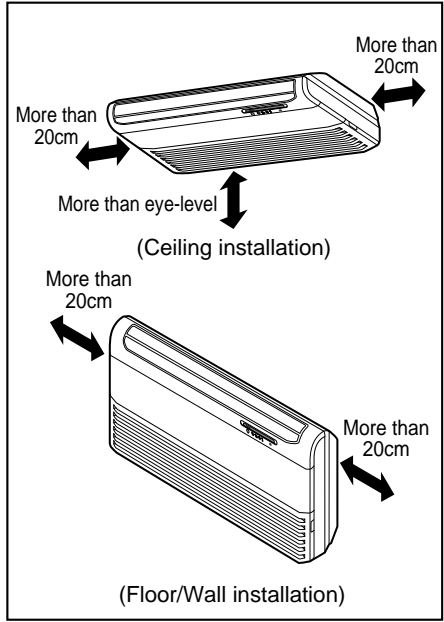

#### 2) Outdoor unit

- If an awning is built over the unit to prevent direct sunlight or rain exposure, be careful that heat radiation from the condenser is not restricted.
- There should not be any animals or plants which could be affected by hot air discharged.
- Ensure the spaces indicated by arrows from the wall, ceiling, fence or other obstacles.

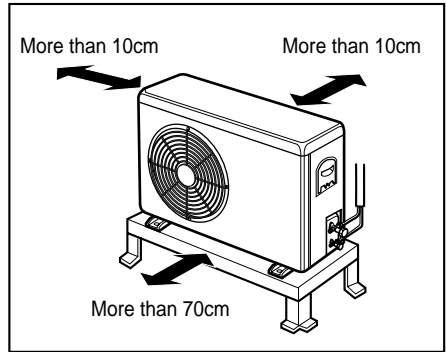

### 3) Piping length and the elevation

MODEL	Pipe Size		Length A(m)		Elevation B(m)		* Additional refrigerant (g/m)
	GAS	LIQUID	Rated	Max.	Rated	Max.	
18K BTU	1/2"	1/4"	7.5	15	5	8	30
24K BTU	5/8"	1/4"	7.5	20	5	8	30
28K BTU	5/8"	3/8"	7.5	25	5	8	30

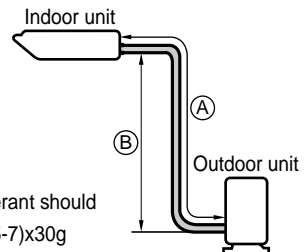

- If 18K or 24K Model is installed at a distance of 15m, 240g of refrigerant should be added.....(15-7)x30g

## 2. Indoor unit installation

### ■ Before Installing, prepare Installation Plates

- 'Installation Plates' are attached at the bottom of indoor unit.  
Detach them by removing each 3 screws at both sides.
- Detach 'Side Plate (R,L)' by removing each 2 screws on both sides.
- Pull the upper right and left side of 'Inlet Grille' to the front, and it will stop at slightly tilted position.
- Unhook the 'Inlet hanger' from the 'Hanger screw' on the both left and right side.
- Detach the 'Inlet Grille' from the Indoor Unit.

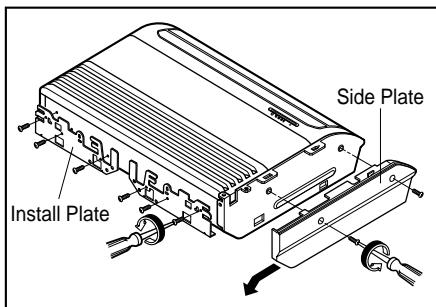

### 1) Installation on the ceiling

- Measure and mark the position for the Suspension bolts and the piping hole.
- Drill the hole for anchor nut on the ceiling.

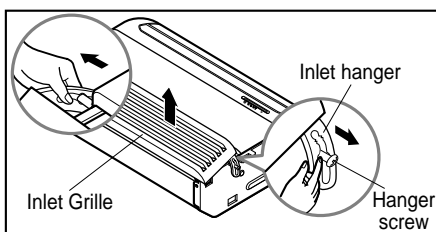

- ※ Before secure the Installation Plates, select the bent direction of the Installation Plate to the inside or the outside according to the installation circumstances.

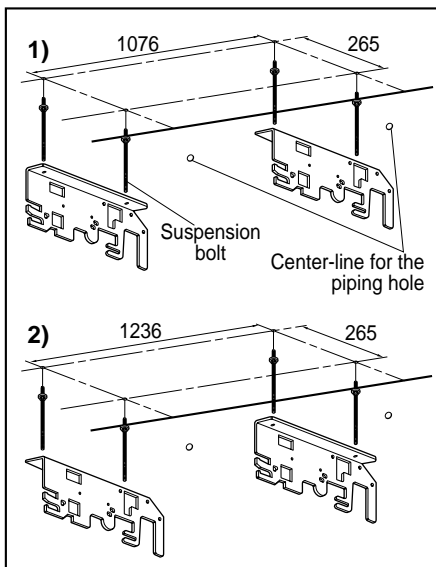

- Drill the piping hole on the wall slightly tilted to the outdoor side using a  $\varnothing 70$  hole-core drill.

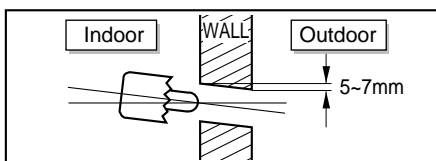

- Insert the nuts and washer onto the suspension bolts for locking the suspension bolts on the ceiling.
- Mount the suspension bolts to the anchor-nuts firmly.
- Secure the Installation plates onto the Suspension bolts (adjust level roughly.) using nuts, washers and spring washers.

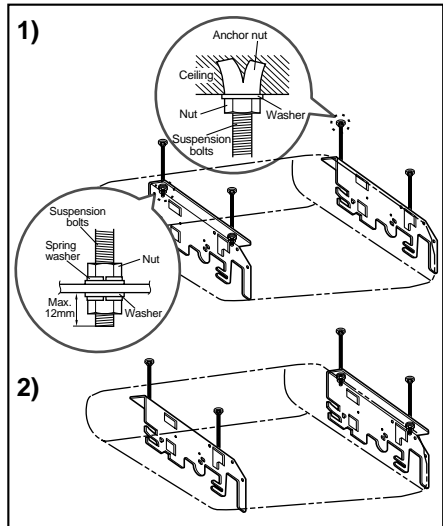

- Engage 2 hooks on the both left and right side of the unit to the lower slot of Installation Plates.
- Adjust a level with a level gauge on the direction of left-right, back-forth by adjusting suspension bolts.
- Move the hooks on the unit to the upper slot of Installation Plates. Then the unit will be declined to the bottomside so as to drain well.

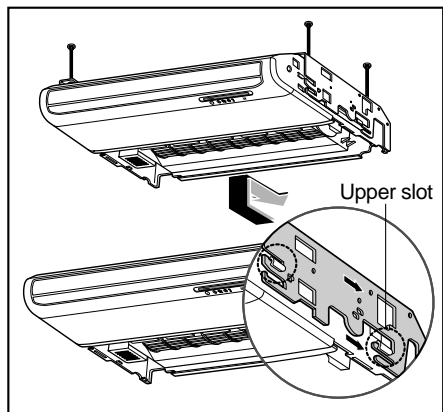
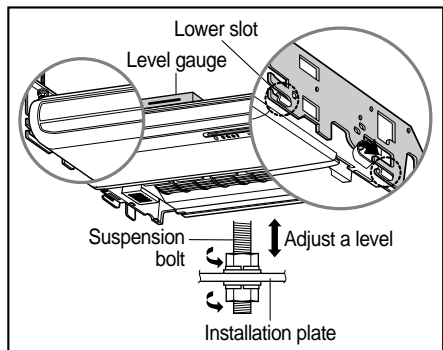

**CAUTION**

1. **Install declination** of the indoor unit is very **important for the drain** of the convertible type air conditioner.
2. Minimum thickness of the insulation for the connecting pipe shall be 7mm.
3. If the Installation Plates are fixed to horizontal line, the indoor unit after installing will be declined to the bottomside.

**Front of view**

- The unit must be horizontal or declined to the drain hose connected when finished installation.

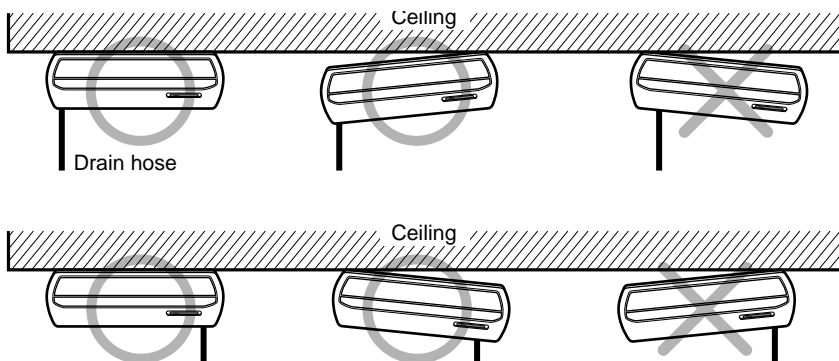
**Side of view**

- The unit must be declined to the bottomside of the unit when finished installation.

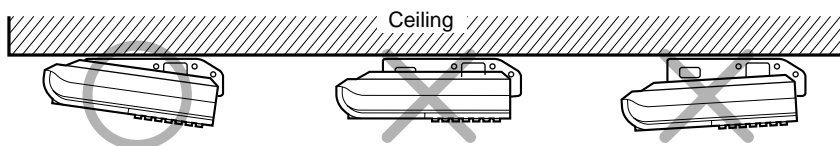

- Secure the unit to the Installation Plates with four M8 bolts and washers.

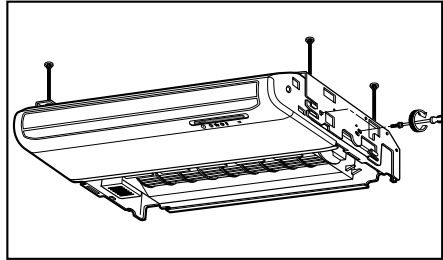

- Before working, refer to "Connecting pipe and cable to Indoor Unit" on page 12.

- Hook up the Inlet Grille Hook to the cabinet.
- Hang the Inlet Hanger to the screw.

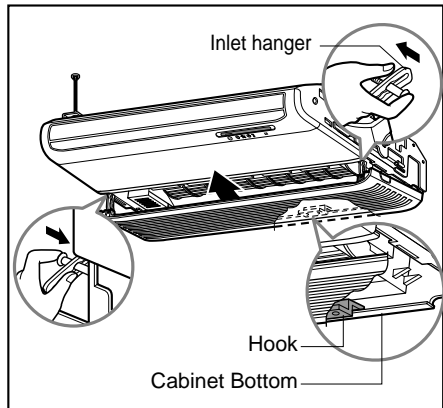

- Fit the projection hooks of the side plates to the 'Side Panel' and the 'Front Panel' by lifting it.
- Fasten the screws.

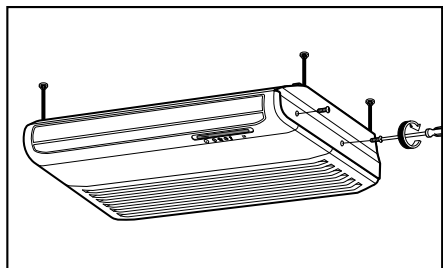
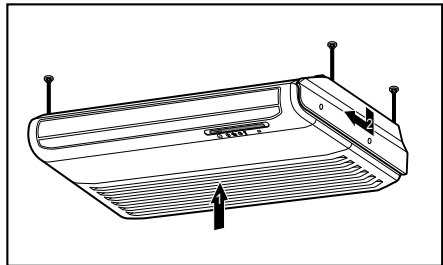



## 2) Installation on the Wall

- Select and mark the position for fixing bolts and piping hole.  
Decide the position for fixing bolts slightly tilted to the drain direction after considering the direction of drain hose.
- Drill the hole for anchor nut on the wall.

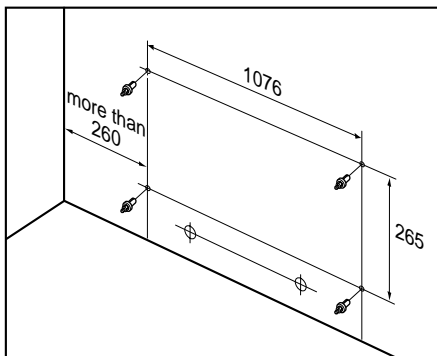

- Drill the piping hole on the wall slightly tilted to the outdoor side using a  $\varnothing 70$  hole-core drill.

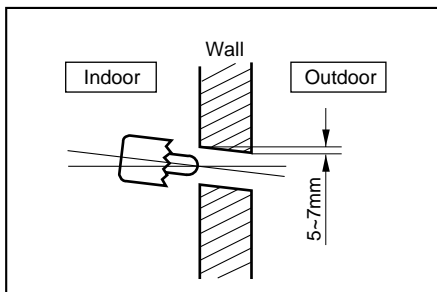

- Secure the 'Install Plate' onto the wall with four anchor bolts, washers and spring washers.

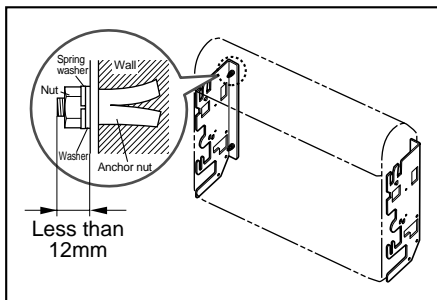

- ※ Before secure the Install Plates, select the bent direction of the 'Install Plate' to the inside or outside according to the installation circumstances.

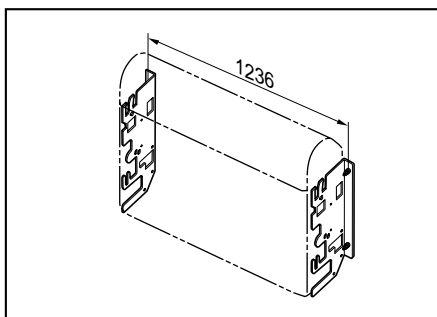

Install the Indoor unit onto Installation Plate.

- Insert 2 hooks on the both left and right side of the unit to the inner slot (wall side) of the Installation Plate.
- Secure the unit to the Installation Plate with four M8 bolts and washers.

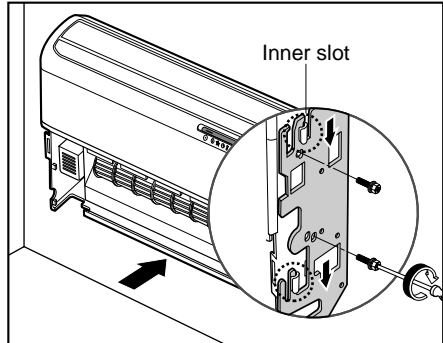

- Before working, refer to "Connecting pipe and cable to Indoor Unit" on page 12.

- Hook up the Inlet Grille Hook to the cabinet.
- Hang the Inlet Hanger to the screw.

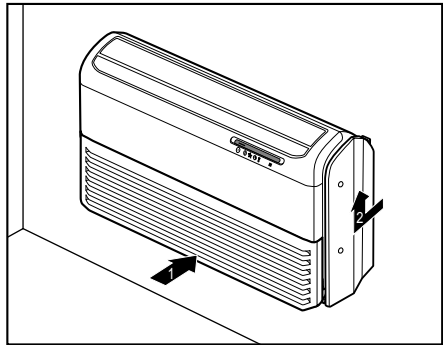

- Fit the projection hooks of the side plates to the 'Side Panel' and the 'Front Panel' by lifting it.
- Fasten the screws.

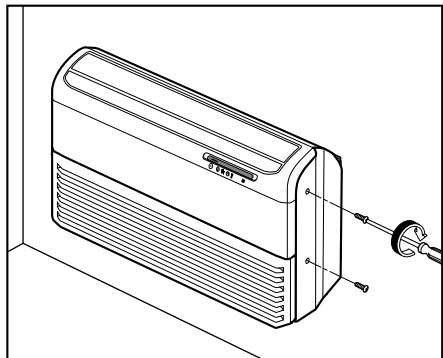

### 3) Installation on the floor

Installation of Mount Bracket.

- Select and mark the position for Mount Brackets and the piping hole.
- Drill the hole for the anchor nut on the wall.
- Drill the piping hole using a  $\varnothing 70$  hole-core drill.
- Secure the Mount Brackets on the wall with four M4 screws.

Install the indoor unit onto the Mount Brackets.

- Engage the slot at the back of the unit with Mount Bracket.

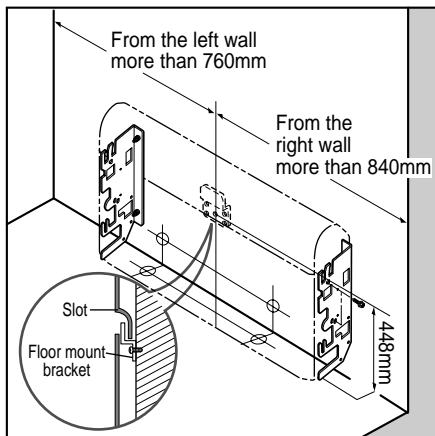

- Drill the piping hole with 70mm dia, hole core drill.
- Piping hole should be slightly slant to the outdoor side.

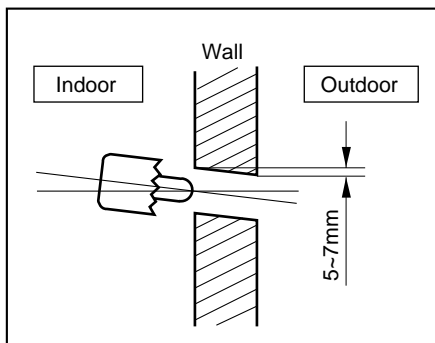

#### **After Installing, reassemble detached parts.**

- Hang the 'Inlet Grille' and hook the 'Inlet Hanger' to the Hanger Screw.
- Assemble the 'Side Plates(R,L)' with 2 screws on both left and right side.

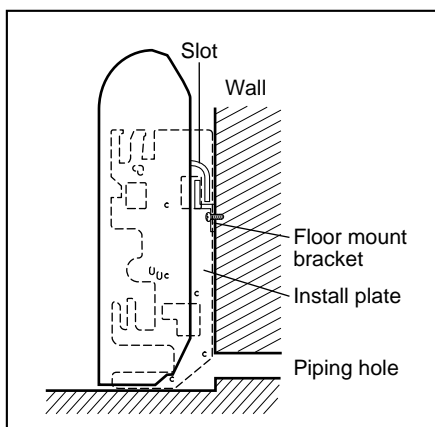

# 3. Connecting Pipes to the Indoor Unit

## 3-1. Preparation of Piping

Main cause of gas leakage is defect in flaring work. Carry out correct flaring work in the following procedure.

### 1) Cut the pipes and the cable.

- Use the accessory piping kit or the pipes purchased locally.
- Measure the distance between the indoor and the outdoor unit.
- Cut the pipes a little longer than measured distance.
- Cut the cable 1.5m longer than the pipe length.

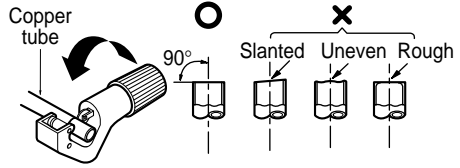

### 2) Burrs removal

- Completely remove all burrs from the cut cross section of pipe/tube.
- Put the end of the copper tube/pipe to downward direction as you remove burrs in order to avoid to let burrs drop in the tubing.

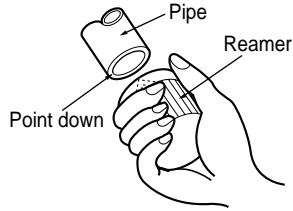

### 3) Putting nut on

- Remove flare nuts attached to indoor and outdoor units, then put them on pipe/tube having completed burr removal.  
(Not possible to put them on after flaring work)

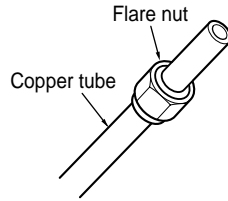

### 4) Flaring work

- Carry out flaring work using flaring tool as shown below.

Outside diameter		A
mm	inch	mm
Ø6.35	1/4	0.5~0.8
Ø9.52	3/8	0.5~0.8
Ø12.7	1/2	0.5~0.8
Ø15.88	5/8	0.8~1.0

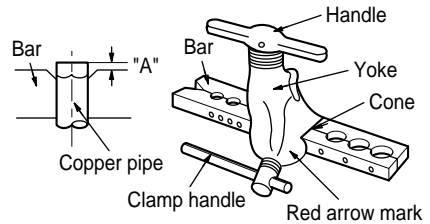

Firmly hold copper tube in a die as indicated dimension in the table above.

### 5) Check

- Compare the flared work with figure below.
- If flare is noted to be defective, cut off the flared section and do flaring work again.

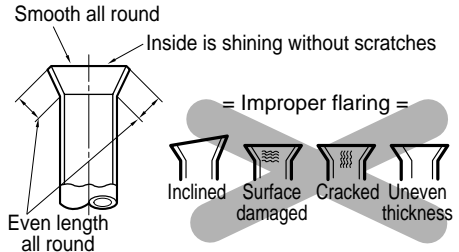

## 3-2. Installation on the ceiling

### 1) Connecting the pipes to the indoor unit

The pipe can be connected to right side, bottom or back of the unit.

#### 1. For the Right Side Piping

- After bending an end of the connecting tube, align the center of the pipings and sufficiently tighten the flare nut with fingers.
- Finally, tighten the flare nut with torque wrench until the wrench clicks.
- Connect the Drain Hose insulated to the drain outlet. Drain hose should go through under the Hose Bracket as shown in figure 4.
- Hang the drain hose on the hose hanger and fix it to the hole of the hose bracket with a screw.

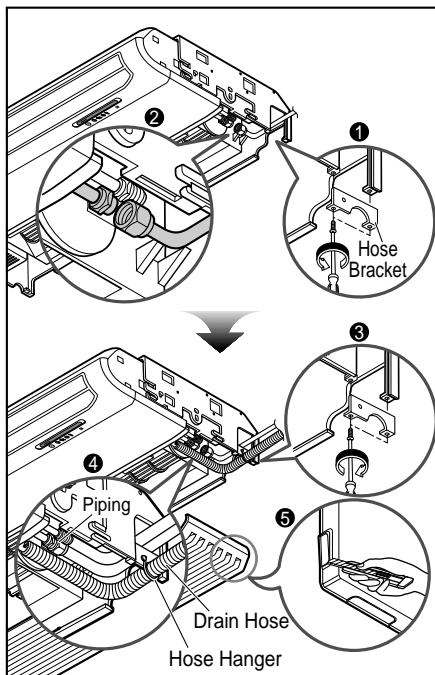

#### 2. For the Bottom Side Piping

- Remove the knock-out on the bottomside of Inlet Grille
- Align the center of the pipings and sufficiently tighten the flare nut with fingers.
- Finally, tighten the flare nut with torque wrench until the wrench clicks.
- Connect the Drain Hose insulated to the drain outlet.
- Hang the drain hose on the hose hanger and fix it to the hole of cabinet bottom with a screw.

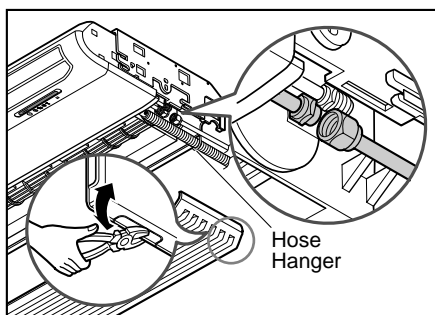

### 2) Connecting the Drain Hose

- The drain hose can be connected to not only the right side but also left side of the unit.
- If the drain hose is connected to the left side, it should go through the cabinet bottom.
- Hang the drain hose on the hose hanger and fix it to the hole of cabinet bottom with a screw.

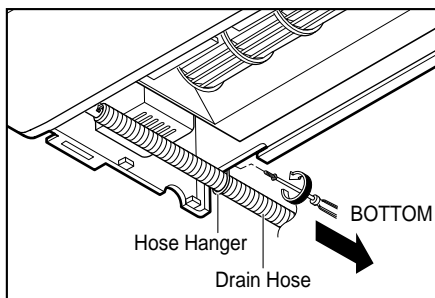

### 3-3. Installation on the wall or floor

#### 1) Connecting the pipes to the indoor unit

##### 1. For the Right Rear Piping

- Remove the knock-out at the back side of the cabinet.
- After bending an end of the connecting tube, align the center of the pipings and sufficiently tighten the flare nut with fingers.
- Finally, tighten the flare nut with torque wrench until the wrench clicks.
- Connect the Drain Hose insulated to the drain outlet.
- Tape the Drain Hose to the pipings to avoid coming off the drain-outlet.

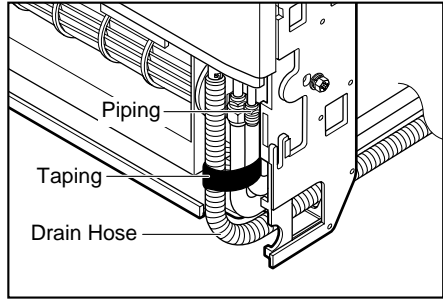

##### 2. For the Right Side Piping

- After bending an end of the connecting tube, align the center of the pipings and sufficiently tighten the flare nut with fingers.
- Finally, tighten the flare nut with torque wrench until the wrench clicks.
- Connect the Drain Hose insulated to the drain outlet.
- Tape the Drain Hose to the pipings to avoid coming off the drain-outlet.

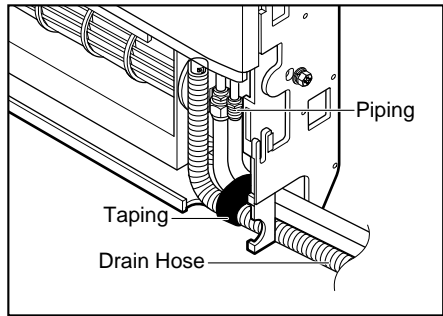

##### 3. For the Right Bottom Piping

- Align the center of the pipings and sufficiently tighten the flare nut with fingers.
- Finally, tighten the flare nut with torque wrench until the wrench clicks.
- Connect the Drain Hose insulated to the drain outlet.

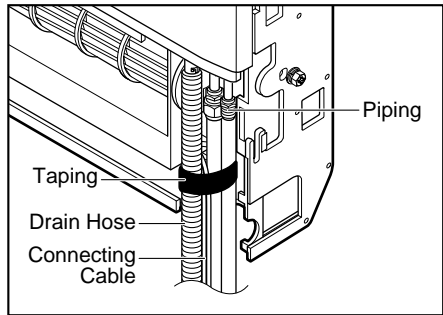

#### 2) Connecting the Drain Hose

- The drain hose can be connected to not only right side but also left side of the unit.

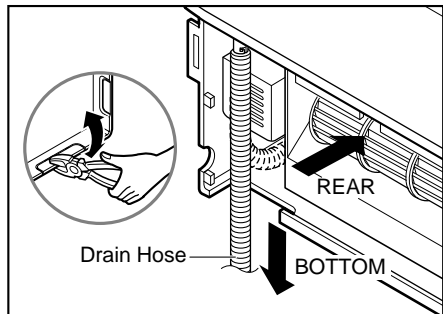

## 4. Connecting Pipes to the Outdoor Unit

### ■ Connecting the pipes to the Outdoor unit

1. **Align the center of the pipings and sufficiently tighten the flare nut with fingers.**
2. **Finally, tighten the flare nut with torque wrench until the wrench clicks.**
  - When tightening the flare nut with torque wrench, ensure the direction for tightening follows the arrow on the wrench.

Pipe Size		Torque
Liquid Side	1/4"	1.8kg·m
	3/8"	4.2kg·m
Gas Side	1/2"	5.5kg·m
	5/8"	6.6kg·m

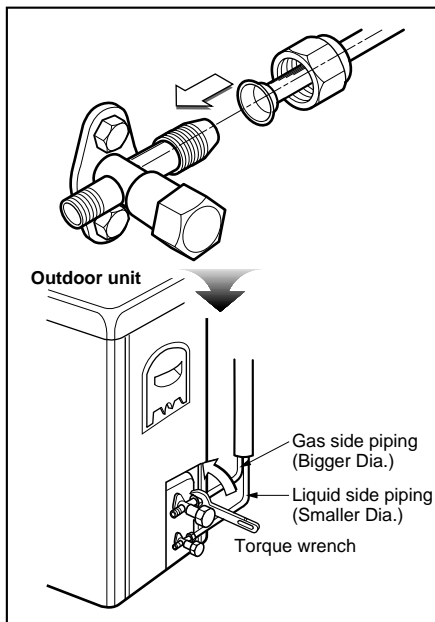

## 5. Checking the Drainage

### ■ Checking the Drainage

1. **Remove the Air Filter.**
  - To remove air filter, take hold of tab and pull slightly upwards.
2. **Check the drainage.**
  - Spray one or two glasses of water upon the evaporator.
  - Ensure that water flows drain hose of indoor unit without any leakage.

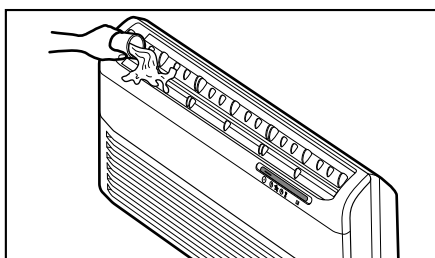
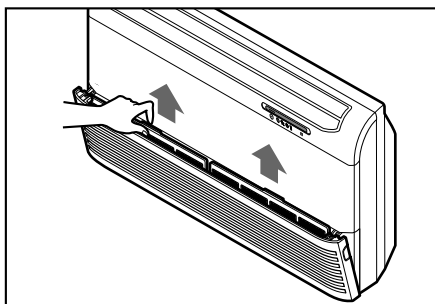

## 6. Connecting Cables between Indoor Unit and Outdoor Unit

### 1) Connecting cables to the Indoor Unit

- 1) Remove the Air guide - L by loosening 2 screws after removing the Inlet grille from the Indoor unit.
- 2) Connect the wires to the terminals on the control board individually according to the outdoor unit connection.

• Ensure that the color of the wires of outdoor unit and the terminal No. are the same as those of indoor unit respectively

< 18K, 24K BTU >

#### • Cooling Model Only

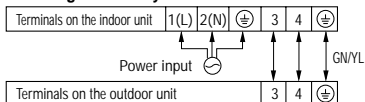

#### • Heat Pump Model

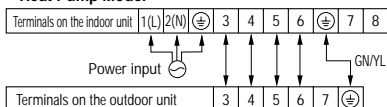

< 28K, 30K BTU >

#### • Cooling Model Only

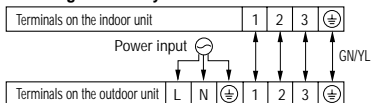

#### • Heat Pump Model

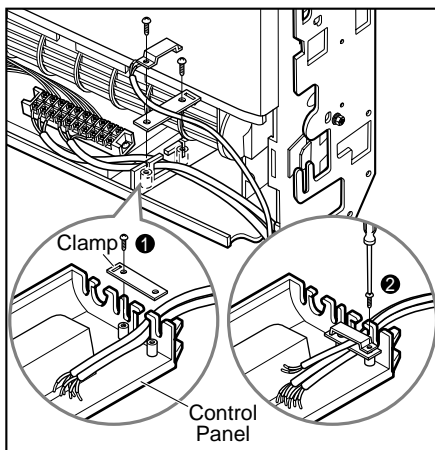
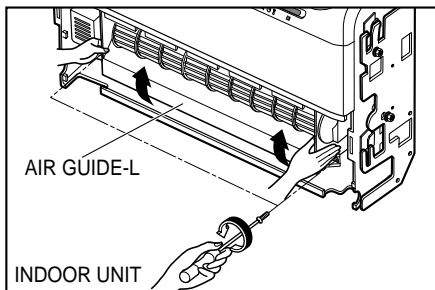
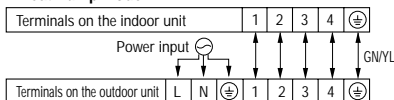

### 2) Clamping of cables

- 1) Arrange 2 power cables on the control panel.
- 2) First, fasten the steel clamp with a screw to the inner boss of control panel.
- 3) For the cooling model, fix the other side of the clamp with a screw strongly.  
For the heat pump model, put the 0.75mm<sup>2</sup> cable (thinner cable) on the clamp and tighten it with a plastic clamp to the other boss of the control panel.
- 4) In Australia, the length of power supply cord measured from the entry of the power supply cord to the middle of live pin on the power plug should be over 1.8m.

### CAUTION

The power cord connected to the indoor unit should be complied with the following specifications (Type H05VV-F (Indoor) approved by HAR or SAA).

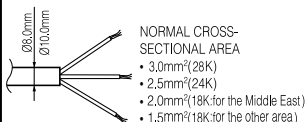

The power connecting cable connected between the indoor and outdoor unit should be complied with the following specifications (Type H07RN-F approved by HAR or SAA).

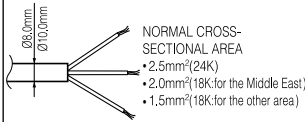

The connecting cable connected between the indoor and outdoor unit should be complied with the following specifications (Type H07RN-F approved by HAR or SAA).

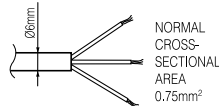



### 3) Connecting the cable to Outdoor Unit

1. Remove the Cover control from the unit by loosening a screw.  
Connect the wires to the terminals on the control board individually as following.
2. Secure the cable onto the control board with the holder (clamper).
3. Refix the cover control to the original position with the screw.
4. Use a recognized circuit breaker 20A(18K, 24K) between the power source and the unit.  
A disconnection device to adequately disconnect all supply lines must be fitted.

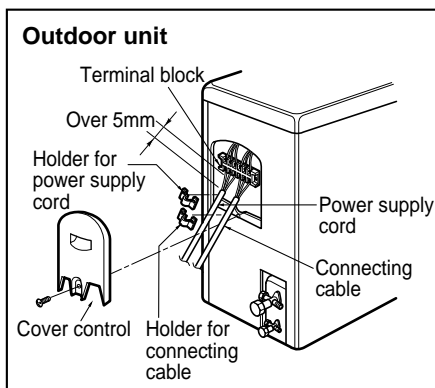

#### CAUTION

After the confirmation of the above conditions, prepare the wiring as follows:

- 1) **Never fail to have an individual power specialized for the air conditioner. As for the method of wiring, be guided by the circuit diagram pasted on the inside of control box cover.**
- 2) **Provide a circuit breaker switch between power source and the unit.**
- 3) **The screw which fasten the wiring in the casing of electrical fittings are liable to come loose from vibrations to which the unit is subjected during the course of transportation. Check them and make sure that they are all tightly fastened. (If they are loose, it could give rise to burn-out of the wires.)**
- 4) **Specification of power source**
- 5) **Confirm that electrical capacity is sufficient.**
- 6) **Be sure that the starting voltage is maintained at more than 90 percent of the rated voltage marked on the name plate.**
- 7) **Confirm that the cable thickness is as specified in the power sources specification. (Particularly note the relation between cable length and thickness.)**
- 8) **Never fail to equip a leakage breaker where it is wet or moist.**
- 9) **The following troubles would be caused by voltage drop-down.**
  - Vibration of a magnetic switch, damage on the contact point there of, fuse breaking, disturbance to the normal function of a overload protection device.
  - Proper starting power is not given to the compressor.
- 10) **The means for disconnection from a power supply shall be incorporated in the fixed wiring and have an air gap contact separation of at least 3mm in each active(phase) conductors.**

#### 4) Form the pipings

1. **Wrap the connecting portion of indoor unit with the Insulation material and secure it with two Plastic Bands. (for the right pipings)**

- If you want to connect an additional drain hose, the end of the drain-outlet should keep distance from the ground. (Do not dip it into water, and fix it on the wall to avoid swinging in the wind.)

In case of the Outdoor unit being installed below position of the Indoor unit.

2. **Tape the Pipings, drain hose and Connecting Cable from bottom to top.**
3. **Form the pipings gathered by taping along the exterior wall and fix it onto the wall by saddle or equivalent.**

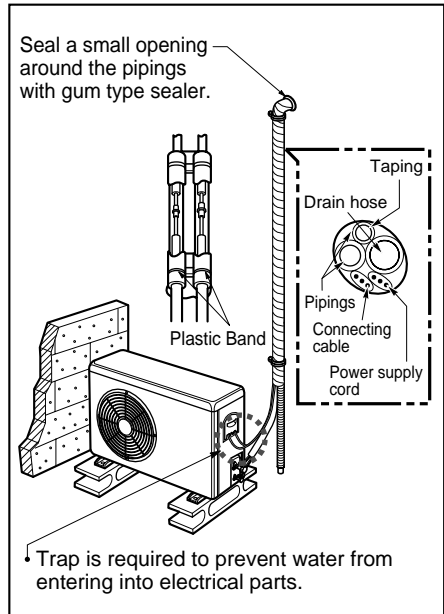

In case of the Outdoor Unit being installed above position of the Indoor Unit.

2. **Tape the Pipings and Connecting cable from bottom to top.**
3. **Form the pipings gathered by taping along the exterior wall, and make the trap prevent water from entering into the room.**
4. **Fix the pipings onto the wall by saddle or equivalent.**

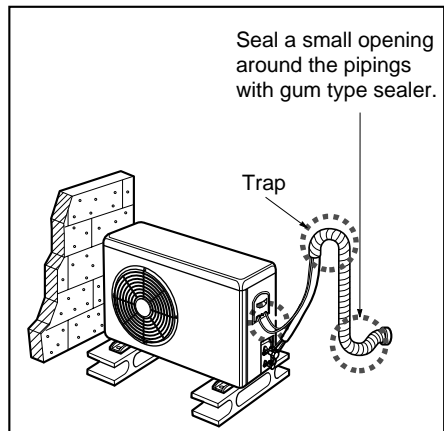

## 7. Air Purging of the Connecting Pipes and Indoor Unit

The air which contains moisture remaining in the refrigeration cycle may cause a malfunction on the compressor.

1. Confirm that both the liquid side valve and the gas side valve are set to the closed position.
2. After connecting the piping, check the joints for gas leakage with gas leak detector.
3. Remove the service port nut, and connect the gauge manifold and the vacuum pump to the service port by the charge hose.
4. Vacuum the indoor unit and the connecting pipes until the pressure in them lowers to below -76cmHg.
5. Remove the valve stem nuts, and fully open the stems of the 2-way and 3-way valves with a hexagon wrench.
6. Tighten the valve stem nuts of the 2-way valve and 3-way valve.
7. Disconnect the charge hose and fit the nut to the service port.  
(Tightening torque: 1.8kg.m)

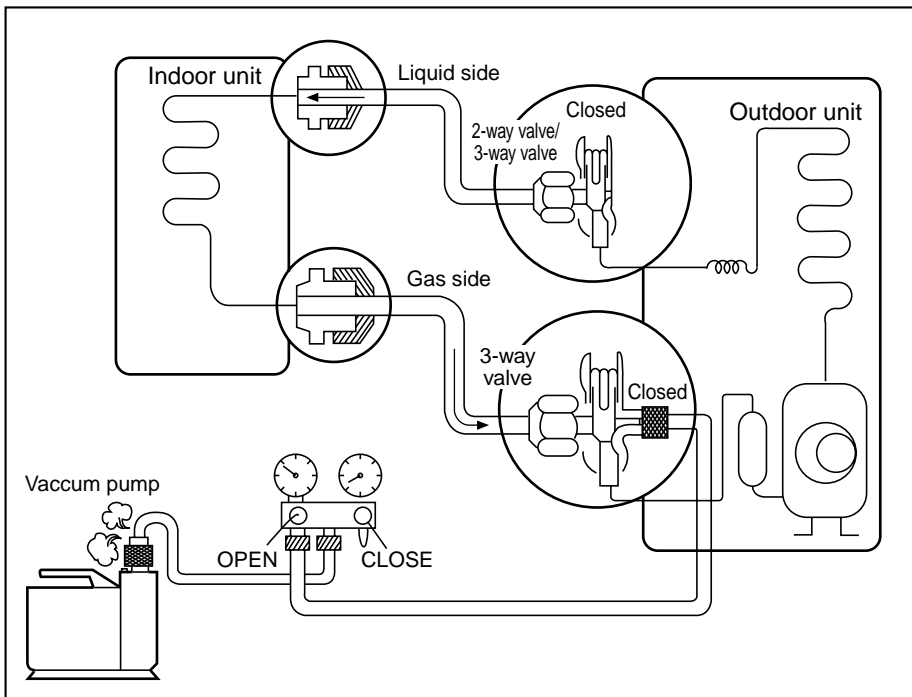

## 8. Test running

### 1) Connection of power supply

#### 1. Connect the power supply cord to the independent power supply.

- Circuit breaker is required.

#### 2. Prepare the remote control.

- Insert two batteries provided.  
Remove the battery cover from the remote controller.
- Slide the cover according to the arrow direction.  
Insert the two batteries.
- (Two "R03" or "AAA" dry-cell batteries or equivalent.)
- Be sure that the (+) and (-) directions are correct.
- Be sure that both batteries are new.
- Re-attach the cover.
- Slide it back into position.

#### 3. Operate the unit for fifteen minutes or more.

### 2) Evaluation of the performance

#### 1. Measure the temperature of the intake and discharge air.

#### 2. Ensure the difference between the intake temperature and the discharge one is more than 8°C (Cooling) or reversely (Heating).

### 3) Selection of the slide switch according to installation method

#### 1. In case the indoor unit is installed on the floor, please change the switch which is on the Main PCB Ass'y to the "BOTTOM" state.

#### 2. In case the indoor unit is installed under the ceiling, please change the switch which is on the Main PCB Ass'y to the "ceiling" state.

- ※ The initial state of the slide switch is set for the bottom installation.

