



website <http://www.lgservice.com>
e-mail <http://www.lgeservice.com/techsup.html>

LG

ENGLISH

ESPAÑOL

LG

Multi Type Air Conditioner

INSTALLATION MANUAL

IMPORTANT

- Please read this instruction sheet completely before installing the product.
- When the power cord is damaged, replacement work shall be performed by authorized personnel only.
- Installation work must be performed in accordance with the national wiring standards by authorized personnel only.

TABLE OF CONTENTS

Installation Requirements

Installation Parts Provided	3
Safety Precautions	4~5
Installation of indoor, outdoor unit	6~11
Flaring work and connection of piping	12~21
Connecting the Cable between Indoor Unit and Outdoor Unit	22~24
Checking the Drainage, Forming the Pipings and Long pipe Setting	25~27
Air Purging and Evacuation	28
Panel Front Assembly	30
Installation PI485	31
Test running	33
Combination indoor units	34
Max Combination Capacity	35
Installation guide at the seaside	36

Required Tools

- Level gauge
- Screw driver
- Electric drill
- Hole core drill (ø70mm)
- Horizontal meter
-
- Flaring tool set
- Specified torque wrenches
1.8kg.m, 4.2kg.m, 5.5kg.m, 6.6kg.m
(different depending on model No.)
- SpannerHalf union
-
- A glass of water
- Screw driver
-
- Hexagonal wrench(4mm)
- Gas-leak detector
- Vacuum pump
- Gauge manifold
-
- Owner's manual
- Thermometer
- Holder Remote Control

Installation Parts Provided

Standard Type

Installation plate		
Type "B" screws		
Type "A" screw (6 EA)	Type "A" screw (8 EA)	Type "A" screw and plastic anchors
Holder Remote Control		

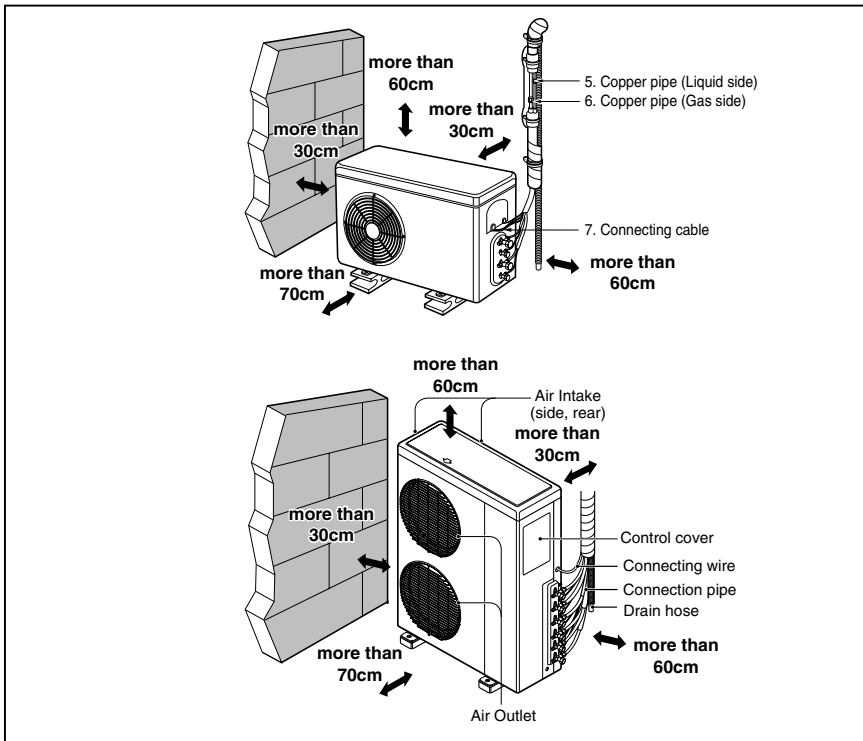

Safety Precautions



To prevent injury to the user or other people and property damage, the following instructions must be followed.

■ Incorrect operation due to ignoring instruction will cause harm or damage. The seriousness is classified by the following indications.

⚠ WARNING This symbol indicates the possibility of death or serious injury.

⚠ CAUTION This symbol indicates the possibility of injury or damage.

■ Meanings of symbols used in this manual are as shown below.

	Be sure not to do.
	Be sure to follow the instruction.

⚠ WARNING

Do not disassemble or repair the product.

- Contact your dealer or service center.

Always earth the product.

- It will cause fire or electric shock.

Do not handle the flammable gas or explosive materials near the product.

- Otherwise, it may cause fire or failure of product.

Do not install where flammable gas could leak.

- Otherwise, it may cause explosion or fire.

Do not install the product on a defected installation stand.

- Otherwise, It may cause injury or accident.

Be cautious when unpacking and installing the product.

- Sharp edges could cause injury.

For installation, always contact the dealer or service center.

- Otherwise, it may cause fire, electric shock, explosion or injury."

For electric work, contact the dealer or service center.

- Otherwise, It will cause fire or electric shock.

Do not use damaged power cable.

- It will cause fire or electric shock.

Always install a circuit breaker and main breaker.

- No installation may cause fire and electric shock.

Do not touch(operate) product with wet hands.

- Otherwise, it may cause fire or electric shock.

If strange sound, smell or smoke come from product, turn the breaker off.

- Otherwise, it may cause electric shock or fire.

Do not put the heater, etc. near the power cable.

- Otherwise, it may cause fire and electric shock.

Cover the electric part.

- Otherwise, it may cause fire or electric shock.

Do not turn the breaker on/off during operation.

- Otherwise, it may cause fire or electric shock.

Do not open the suction inlet of the product during operation.

- Otherwise, it may cause electric shock or failure.

Do not touch the metal parts of the product when removing the air filter.

- Otherwise, it may cause personal injury.

Do not step or put anything on the product.

- Otherwise, it may cause personal injury and failure of product.

Fix the outdoor unit on the floor.

- Otherwise, it can be blown away by the strong wind. It will cause injury or accident.

CAUTION

Always inspect gas leakage after installation and repair of product.

- Otherwise, it may cause failure of product.

Install the drain hose to ensure that drain can be securely done.

- Otherwise, it may cause water leakage.

Keep the level even while installing the product.

- Otherwise, it may cause vibration or water leakage.

Do not install the product where the noise or hot wind from the outdoor unit could give any casualty to the neighborhood

- Otherwise, it may cause dispute with the neighborhoods.

Installation of Indoor, Outdoor Unit

Read completely, then follow step by step.

Select the best location

Indoor unit

1. Do not have any heat or steam near the unit.
2. Select a place where there are no obstacles in front of the unit.
3. Make sure that condensation drainage can be conveniently routed away.
4. Do not install near a doorway.
5. Ensure the spaces indicated by arrows from the wall, ceiling, fence or other obstacles.
6. Use a stud finder to locate studs to prevent unnecessary damage to the wall.



CAUTION: Install the indoor unit on the wall where the height from the floors more than 2.3 meters. (ART COOL Type Only 1.5m)

Outdoor unit

1. If an awning is built over the unit to prevent direct sunlight or rain exposure, make sure that heat radiation from the condenser is not restricted.
2. Ensure that the spaces indicated by arrows around front, back and side of the unit.
3. Do not place animals and plants in the path of the warm air.
4. Take the air conditioner weight into account and select a place where noise and vibration are minimum.
5. Select a place so that the warm air and noise from the air conditioner do not disturb neighbors.

Rooftop Installations:

If the outdoor unit is installed on a roof structure, be sure to level the unit. Ensure the roof structure and anchoring method are adequate for the unit location. Consult local codes regarding rooftop mounting.

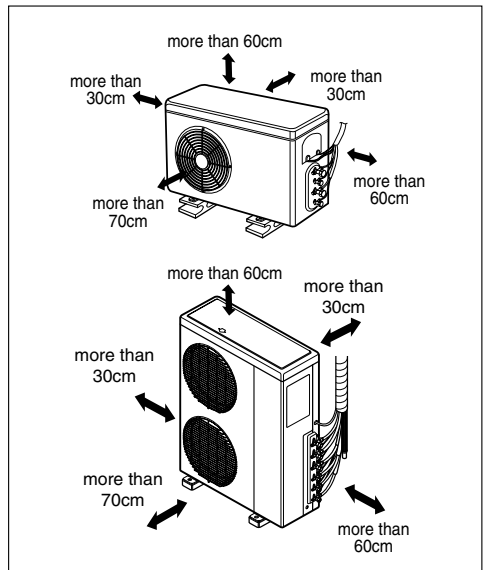
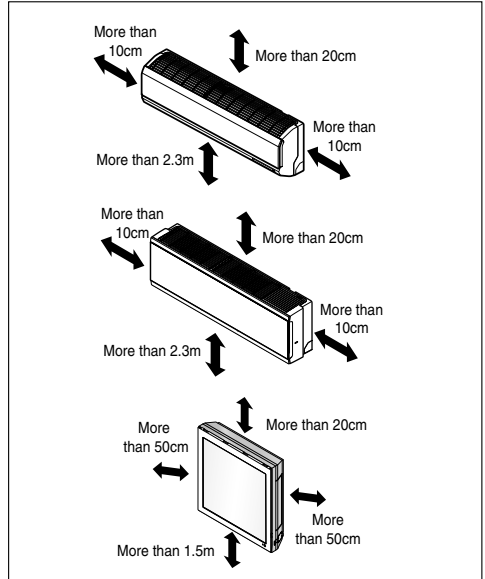

Fixing Installation Plate

The wall you select should be strong and solid enough to prevent vibration

1. Mount the installation plate on the wall with type "A" screws. If mounting the unit on a concrete wall, use anchor bolts.
 - Mount the installation plate horizontally by aligning the centerline using a level.
2. Measure the wall and mark the centerline. It is also important to use caution concerning the location of the installation plate—routing of the wiring to power outlets is through the walls typically. Drilling the hole through the wall for piping connections must be done safely.

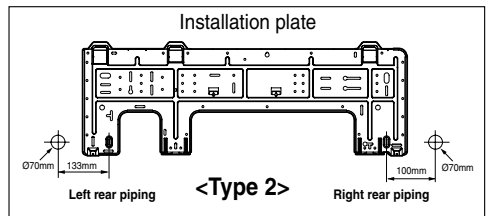
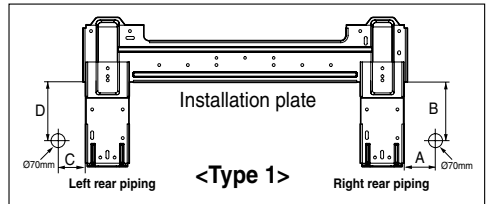
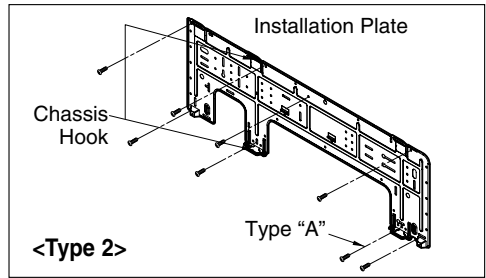
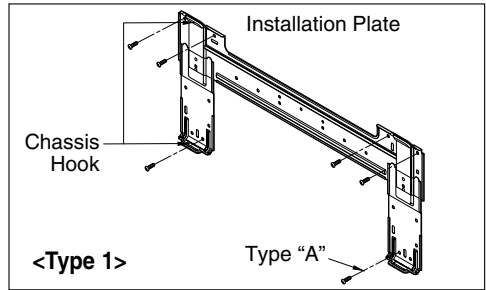

Indoor Type	Capacity (kBtu/h)	Distance (mm)				Type
		A	B	C	D	
Wall mounted	7,9,12	55	105	65	105	1
	18,24	100	122	240	122	2
ART COOL Mirror	7,9,12	70	110	90	110	1
	18,24	100	122	240	122	2

Piping length and elevation

Multi Piping Type

(Unit: m)

Capacity(kBtu/h)	Total Length	Max Length(A/B)	Max Elevation (h1)	In - In Elevation (h2)
21	50	25	15	7.5
24/27	70	25	15	7.5
30	75	25	15	7.5
40	85	25	15	7.5

Distributor Type

(Unit: m)

Phase	Capacity (kBtu/h)	Total Length	Max Main Pipe Length (A/B)	Total Branch Pipe Length	Max Branch Pipe Length	Max Elevation (h1)	In - In Elevation (h2)
1Ø	40	100	50	50	15	30	15
	48	135	55	80	15	30	15
	56	145	55	90	15	30	15
3Ø	42	125	55	70	15	30	15
	48	135	55	80	15	30	15
	54	145	55	90	15	30	15

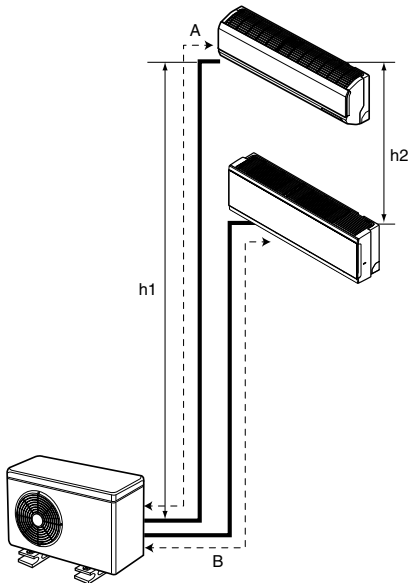

Multi Piping Type

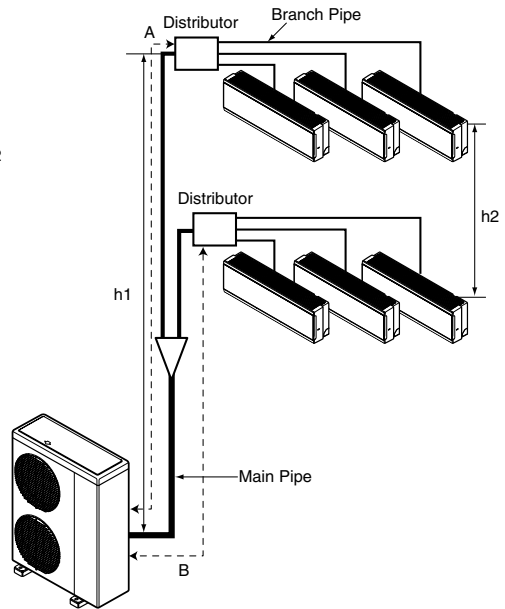

Distributor Type



CAUTION: Capacity is based on standard length and maximum allowance length is on the basis of reliability. If outdoor unit is at higher elevation than the indoor units, after 24m of vertical height, 1 oil trap is required.

Refrigerant charge

The calculation of the additional charge should be taken in account for the length of extra pipe.

Multiple Piping Models

Model	Standard length(m)	Max piping for one room(m)	Max total Piping Length(m)	Additional Charge(g/m)
A3UW216FA3	7.5	25	50	20
A4UW246FA3	7.5	25	70	20
A4UW276FA3	7.5	25	70	20
A5UW306FA3	7.5	25	75	20
A5UW406FA3	7.5	25	85	20

Distributor type Models

Phase	Model	Main Piping length		Branch piping length	
		Standard length(m)	Additional refrigerant(g/m)	Standard length(m)	Additional refrigerant(g/m)
1Ø	A7UW406FA3	5	50	35	20
	A8UW486FA3	5	50	40	20
	A9UW566FA3	5	50	45	20
3Ø	A7UW428FA3	5	50	35	20
	A8UW488FA3	5	50	40	20
	A9UW548FA3	5	50	45	20

Multiple Piping Models

Additional charge (g) = ((A Room Installation Length – Standard Length) x 20g/m
 + (B Room Installation Length – Standard Length) x 20g/m +..
 - CF(Correction Factor) x 150

※ CF = Max. number of connectable indoor unit – Total number of connected indoor unit

Distributor type Models

Additional charge (g) = ((Total Main piping Length - Main Standard Length) x 50g/m
 + (A Room Branch Length – Standard Length) x 20g/m
 + (B Room Branch Length – Standard Length) x 20g/m
 + (C Room Branch Length – Standard Length) x 20g/m +..
 - CF(Correction Factor) x 100

※ CF = Max. number of connectable indoor unit – Total number of connected indoor unit

Additional Charge Calculation Example-1

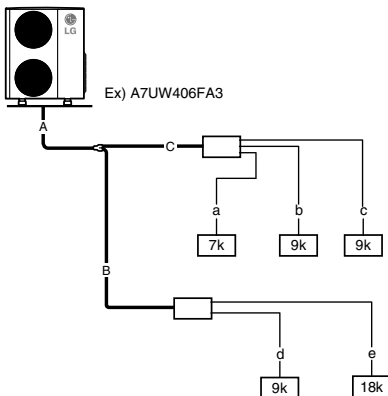

- Total main pipe(A+B+C) = 30m
- Each branch pipe
 a = 10m
 b = 8m
 c = 5m
 d = 3m
 e = 10m

◆ Additional Charge

$$= ((30-5) \times 50 + (10-5) \times 20 + (8-5) \times 20 + (5-5) \times 20 + (3-5) \times 20 + (10-5) \times 20 - (7-5) \times 100 = 1270g$$

Preparing work for Installation (ART COOL Type Only)

Open panel front

1. First, push the front panel backward and lift it up to remove the two screws.
2. The moment of lifting the both lower parts of panel front, you can hear sound this panel came out, In this time panel front is separated
3. After pull down this panel a bit, and separate connecting wire with product.

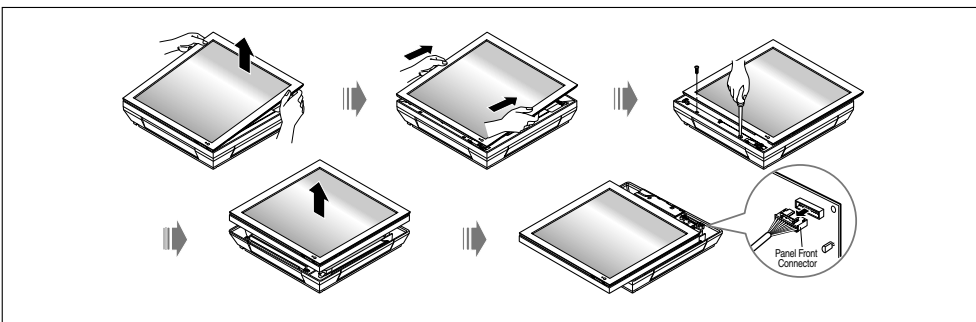
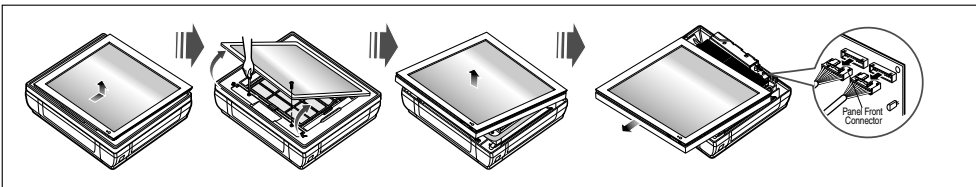

Remove cover pipe and cover side

1. Remove two screws (for fixing cover pipe)
2. Pull up the cover side of desired connecting direction, then cover side is separated.
3. In case of connecting direction is left or right, path through the hole of cover side.



CAUTION: After removing the pipe hole, cut the burr for safety.

NOTICE When connecting pipe path through rear wall, don't remove the hole.

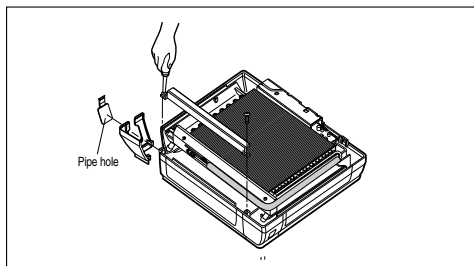

Drain hose junction

1. Remove the rubber stopple of desired direction of drainage.
2. As the following picture, Insert drain hose in the handle of drain pan, and join drain hose and connecting hose.

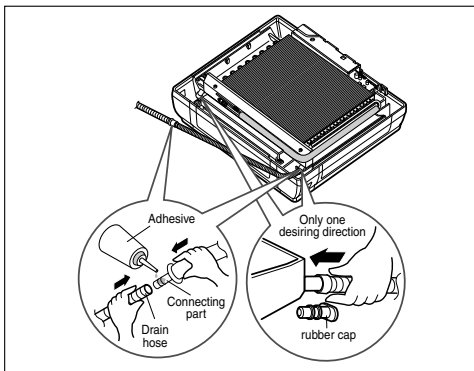

Sticking the installation guide map and fixing Indoor unit (ART COOL Type Only)

Put an Installation Guide Map on the desired surface.

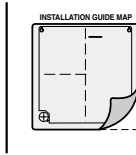

Adjust level even by level guage and fix to installation for reference on the wall.

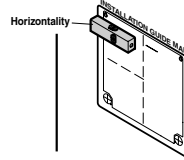

Make a hole with diameter of 6mm and depth of 30-35mm when piercing a screw point.

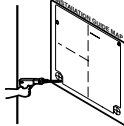

Drill the piercing part for connecting pipe as diameter 50mm. (In case of piercing rear surface)

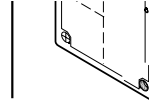

Refer to No. 5 on this page when making a hole in the wall.

Drive the fore plastic anchors into drilled points.

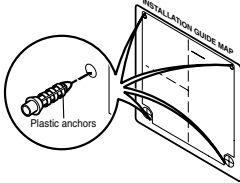

First, Drive the two points of the upper parts by screws (Leave 10mm for hanging product)

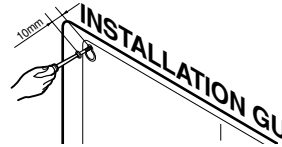

Hang the hole of product at the upper screws. (In this time, Remove the map) (Falling attention)

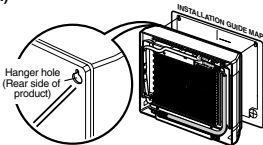

Drive the lower parts after facing the hole of product with plastic anchors, and fix completely the upper screws.

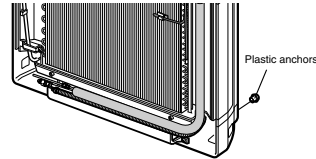

Check the fixed product with light power.

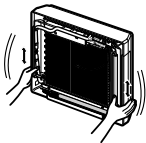

In case of nothing wrong in the matter, connect the pipe and the wire. (Installation manual reference)

Drill a hole in the wall

- Drill the piping hole with a $\phi 70\text{mm}$ hole core drill. Drill the piping hole at either the right or the left with the hole slightly slanted to the outdoor side.

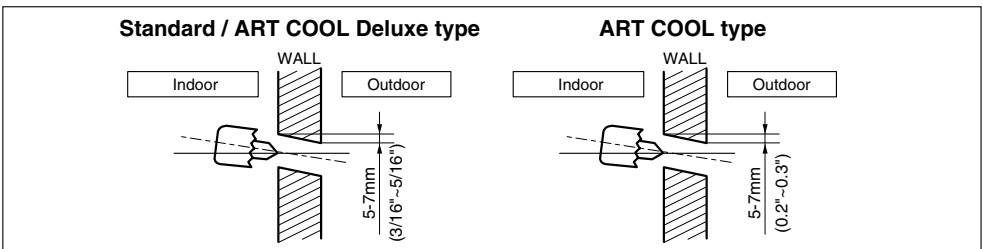

Flaring Work and Connection of Piping

Flaring work

Main cause for gas leakage is due to defect in flaring work. Carry out correct flaring work in the following procedure.

Cut the pipes and the cable.

1. Use the piping kit accessory or the pipes purchased locally.
2. Measure the distance between the indoor and the outdoor unit.
3. Cut the pipes a little longer than measured distance.
4. Cut the cable 1.5m longer than the pipe length.

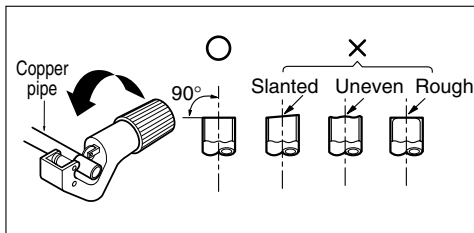

Burrs removal

1. Completely remove all burrs from the cut cross section of pipe/tube.
2. Put the end of the copper tube/pipe in a downward direction as you remove burrs in order to avoid dropping burrs into the tubing.

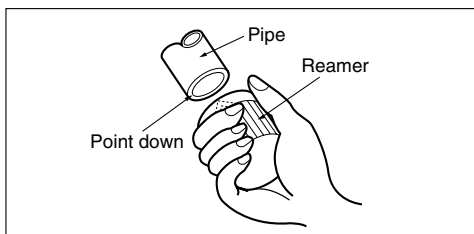

Putting nut on

- Remove flare nuts attached to indoor and outdoor unit, then put them on pipe/tube having completed burr removal.
(not possible to put them on after flaring work)

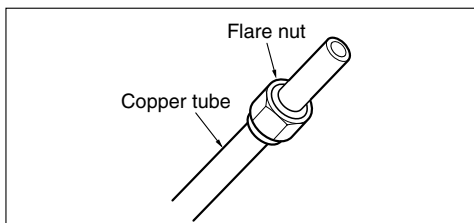

Flaring work

- Carry out flaring work using flaring tool as shown below.
- Firmly hold copper pipe in a die in the dimension shown in the table above.

Outside diameter		A
mm	inch	mm
Ø6.35	1/4	1.1~1.3
Ø9.52	3/8	1.5~1.7
Ø12.7	1/2	1.6~1.8
Ø15.88	5/8	1.6~1.8
Ø19.05	3/4	1.9~2.1

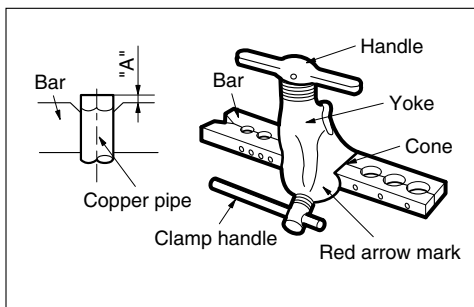

installation of remote control box

Install the remote control box and cord correctly.

POINT OF REMOTE CONTROLLER INSTALLATION

- Although the room temperature sensor is in the indoor unit, the remote control box should be installed in such places away from direct sunlight and high humidity.

INSTALLATION OF THE REMOTE CONTROL BOX

- Select places that is not splashed by water.
- Select control position after receiving customer approval.
- The room temperature sensor of the thermostat for temperature control is built in the indoor unit.
- This remote controller equipped with liquid crystal display. If this position is higher or lower, display is difficult to see.
(The standard height is 1.2~1.5m high)

ROUTING OF THE REMOTE CONTROL CORD

- Keep the remote control cord away from the refrigerant piping and the drain piping.
- To protect the remote control cord from electrical noise, place the cord at least 5cm away from other power cables. (Audio equipment, Television set, etc)
- If the remote control cord is secured to a wall, provide a trap at the top of the cord to prevent water droplets from running.

ELECTRICAL WIRING TO THE INDOOR UNIT

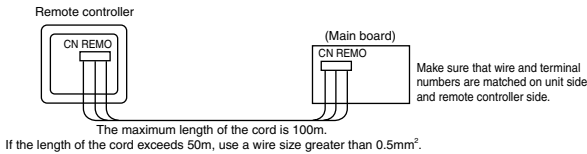

DISASSEMBLING OF THE REMOTE CONTROLLER

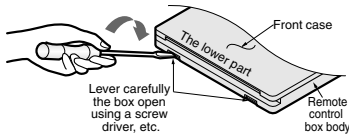

WHEN THE REMOTE CONTROL BOX IS INSTALLED WITH THE CORD EXPOSED.

PROCEDURE OF INSTALLATION

1. Fix the under plate on the wall by self tapping screws (accessory).
2. Make a slit (Part A) at the top side of the remote control box by nipper.
3. Rout the cord as shown in the following figure. In this case, push the cord into the around of case (Part B).
4. Hook the remote control unit on the under plate.

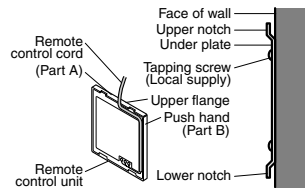

FIXING OF REMOTE CONTROL CORD

1. Fix the cord clamps on the wall by $\phi 3$ tapping screws (Local supply).
2. Fix the remote control cord.

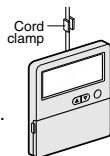

WHEN THE REMOTE CONTROL BOX IS INSTALLED WITH THE CORD BURIED.

PROCEDURE OF INSTALLATION

1. Fix the under plate on the switch box by screws (Local supply). In this case, fit the under plate on the wall, and be careful of deformation.
2. Receive the remote control cord in the switch box.
3. Hook the remote control unit on the under plate.

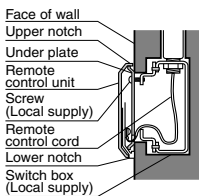

Wired remote controller installation

- Since the room temperature sensor is in the remote controller, the remote controller box should be installed in a place away from direct sunlight, high humidity and direct supply of cold air to maintain proper space temperature.

Install the remote controller about 5ft(1.5m) above the floor in an area with good air circulation at an average temperature.

Do not install the remote controller where it can be affected by:

- Drafts, or dead spots behind doors and in corners.
- Hot or cold air from ducts.
- Radiant heat from sun or appliances.
- Concealed pipes and chimneys.
- Uncontrolled areas such as an outside wall behind the remote controller.
- This remote controller is equipped with a seven segment LED. display. For proper display of the remote controller LED's, the remote controller should be installed properly as shown in Fig. 1. (The standard height is 1.2~1.5 m from floor level.)

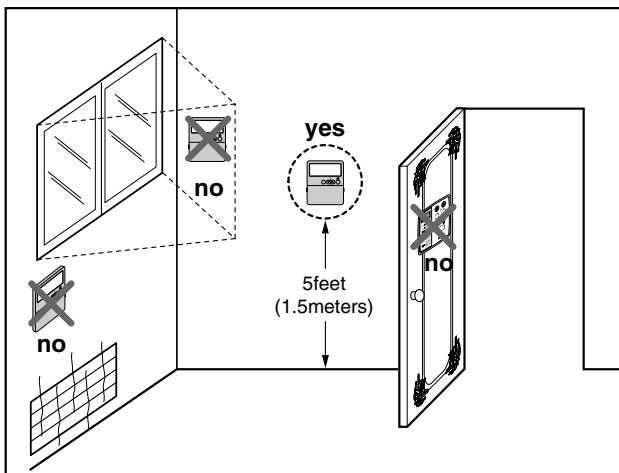
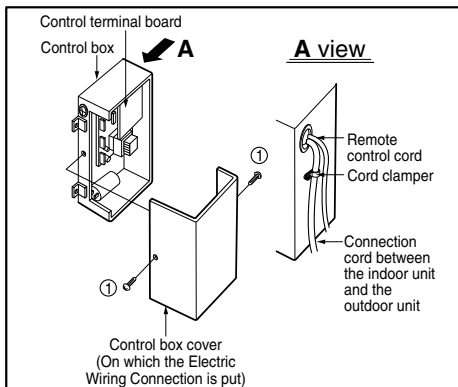

Fig.1 Typical locations for remote controller

WIRING CONNECTION

- Remove the control box cover for electrical connection between the indoor and outdoor unit.
(Remove screws ①.)
- Use the cord clammer to fix the cord.



Check

1. Compare the flared work with figure below.
2. If flare is noted to be defective, cut off the flared section and do flaring work again.

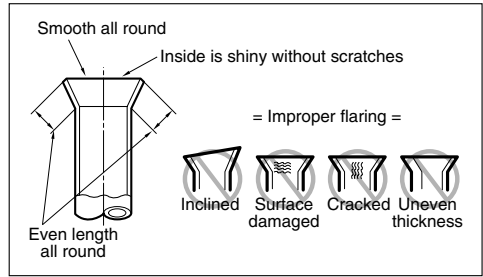

Connection of piping - Indoor

Preparing the indoor unit's piping and drain hose for installation through the wall.

1. Route the indoor tubing and the drain hose in the direction of rear left or right

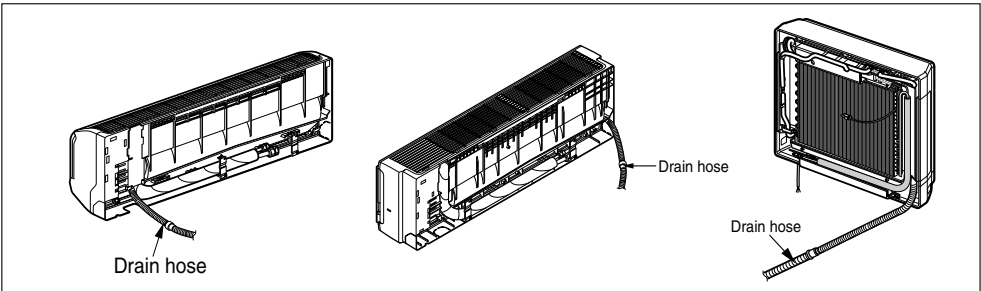

2. Tape the tubing, drain hose and the connecting cable. Be sure that the drain hose is located at the lowest side of the bundle. Locating at the upper side can cause drain pan to overflow inside the unit.

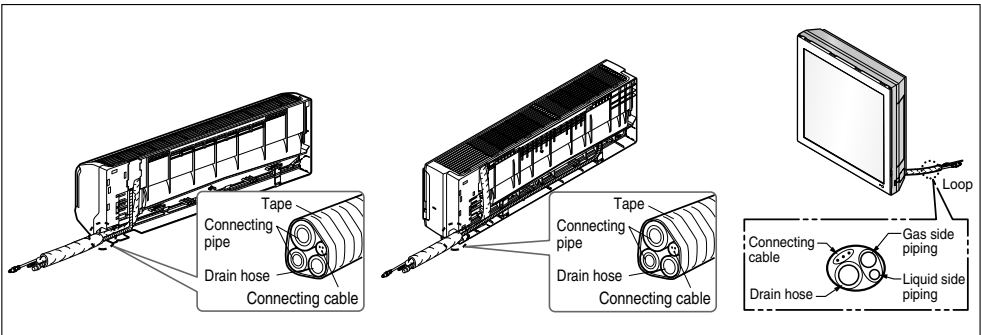

CAUTION: If the drain hose is routed inside the room, insulate the hose with an insulation material* so that dripping from "sweating"(condensation) will not damage furniture or floors.

*Foamed polyethylene or equivalent is recommended.

Indoor unit installation

1. Hook the indoor unit onto the upper portion of the installation plate.(Engage the two hooks of the rear top of the indoor unit with the upper edge of the installation plate.) Ensure that the hooks are properly seated on the installation plate by moving it left and right. Press the lower left and right sides of the unit against the installation plate until the hooks engage into their slots(clicking sound).

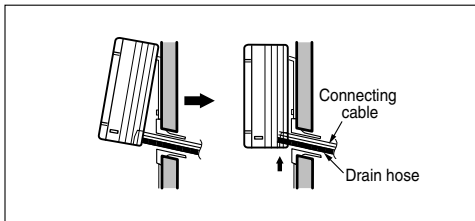

Connecting the pipings to the indoor unit and drain hose to drain pipe

1. Align the center of the pipings and sufficiently tighten the flare nut by hand.
2. Tighten the flare nut with a wrench.

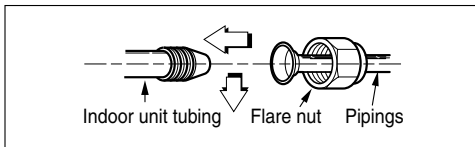

Outside diameter		Torque
mm	inch	
Ø6.35	1/4	1.8~2.5
Ø9.52	3/8	3.4~4.2
Ø12.7	1/2	5.5~6.6
Ø15.88	5/8	6.6~8.2
Ø19.05	3/4	9.9~12.1

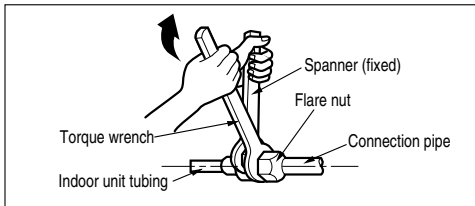

3. When extending the drain hose at the indoor unit, install the drain pipe.

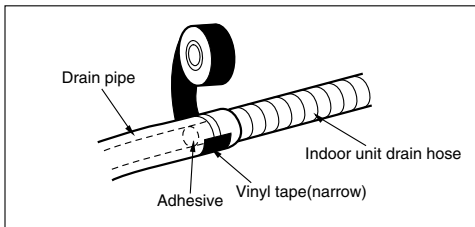

Wrap the insulation material around the connecting portion.

1. Overlap the connection pipe insulation material and the indoor unit pipe insulation material. Bind them together with vinyl tape so that there is no gap.
2. Wrap the area which accommodates the rear piping housing section with vinyl tape.

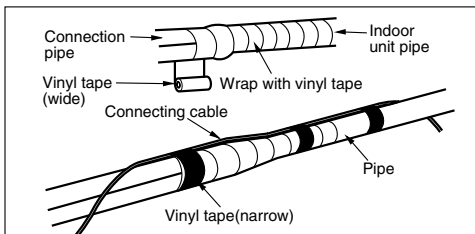
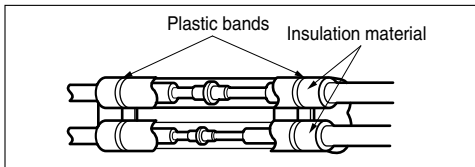

3. Bundle the piping and drain hose together by wrapping them with vinyl tape over the range within which they fit into the rear piping housing section.

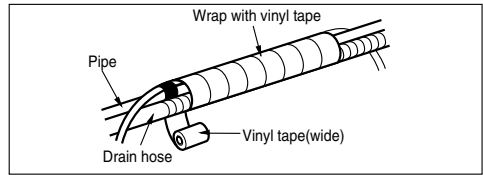

CAUTION: Installation Information (For right piping)
For right piping, follow the instruction below.

Good case

- Press on the upper side of clamp and unfold the tubing to downward slowly.

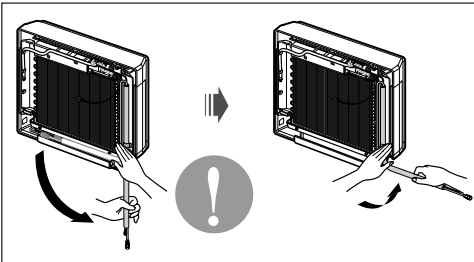

Bad case

- Following bending type from left to right could cause problem of pipe damage.

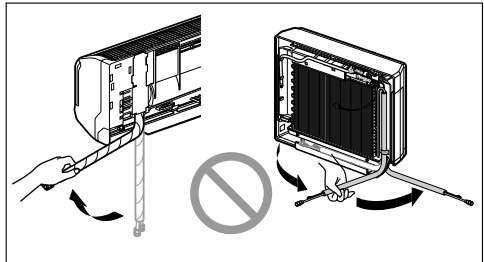

Connection of piping - Outdoor

Align the center of the piping and sufficiently tighten the flare nut by hand.

Connecting pipe order

- 1) A~E-UNIT gas side pipe
- 2) A~E-UNIT liquid side pipe

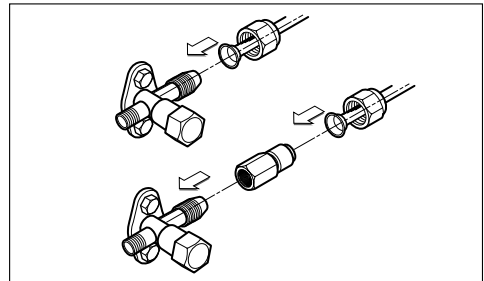

Finally, tighten the flare nut with torque wrench until the wrench clicks.

- When tightening the flare nut with torque wrench ensure the direction for tightening follows the arrow on the wrench.

Outside diameter		Torque kgf.m
mm	inch	
Ø6.35	1/4	1.8~2.5
Ø9.52	3/8	3.4~4.2
Ø12.7	1/2	5.5~6.6
Ø15.88	5/8	6.3~8.2
Ø19.05	3/4	9.9~12.1

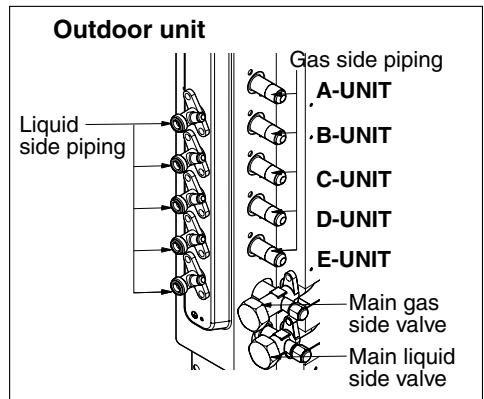

- For the units with capacity more than 48 kBTU/h, the installation piping is connectable in four directions.(refer to figure 1)
- When connecting in a downward direction, knock out the knockout hole of the base pan. (refer to figure 2)

Preventing foreign objects from entering (Figure3)

- Plug the pipe through-holes with putty or insulation material(procured locally)to stop up all gaps,as shown in the figure 3.
- Insects or small animals entering the outdoor unit may cause a short circuit in the electrical box.

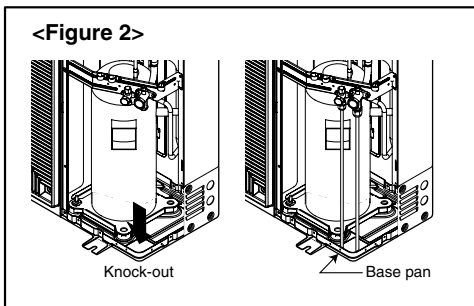
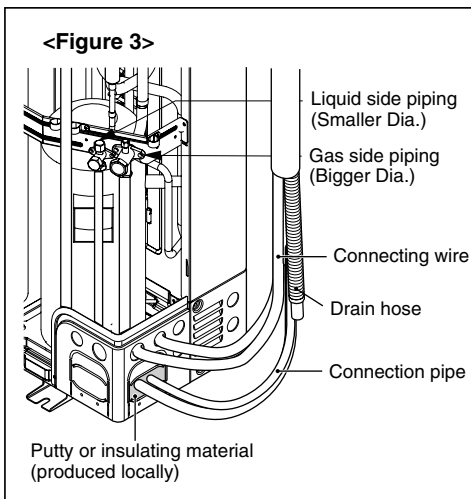
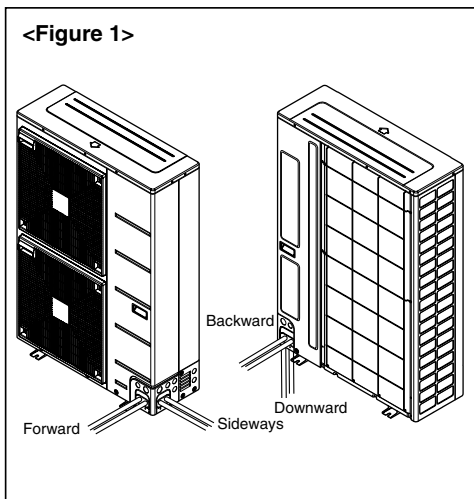
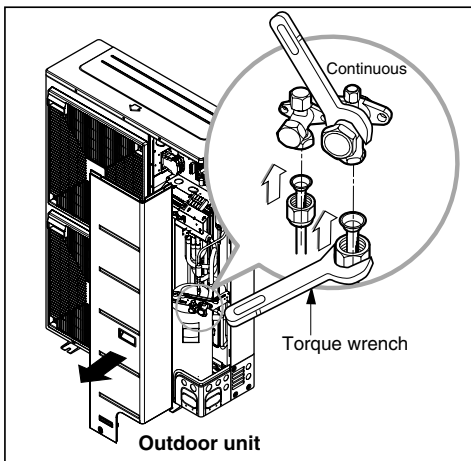

Branch

[unit:mm]

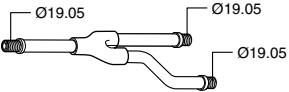
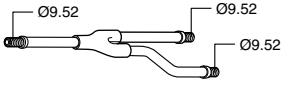
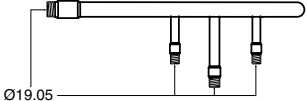
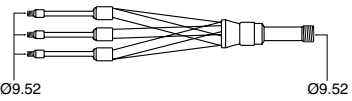
Model	Gas Pipe	Liquid Pipe
PMBL5620		
PMBL1203F0		

■ Y branch

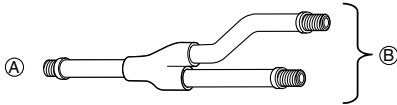

- Ⓐ To Outdoor Unit
- Ⓑ To BD Unit

- Ensure that the branch pipes are attached horizontally or vertically (see the diagram below.)

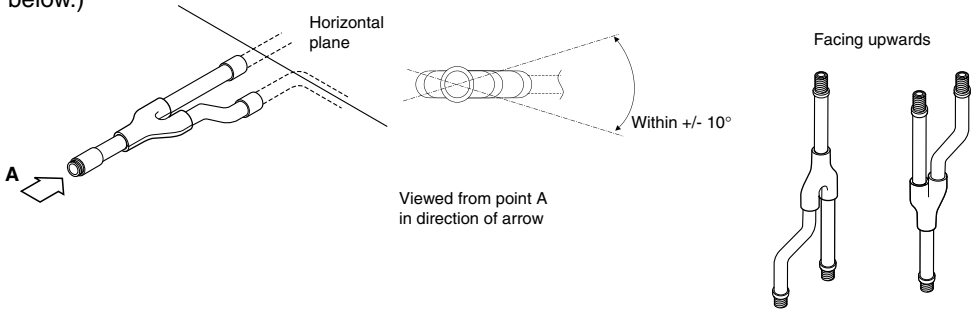

- Branch pipe should be insulated with the insulator in each kit.

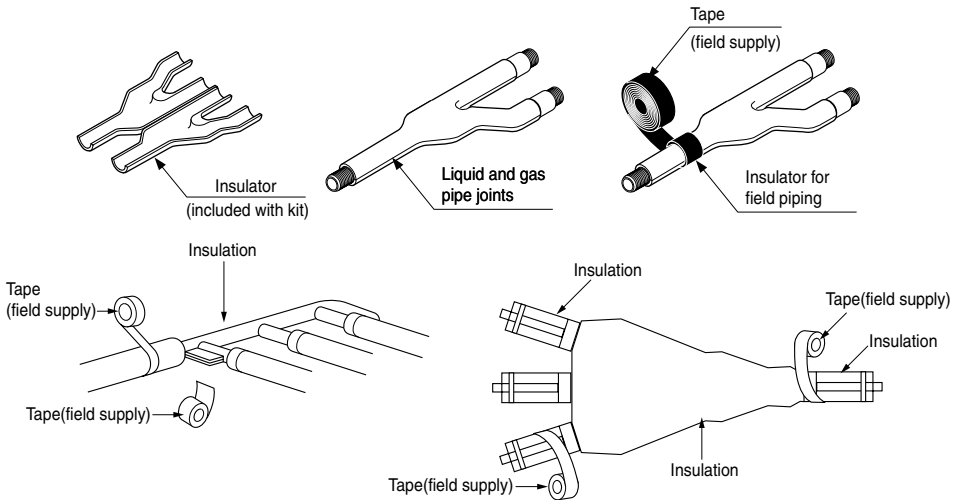

ENGLISH

Installation

- This unit may be installed suspended from the ceiling or mounted on the wall.
- This unit may only be installed horizontally, as shown in the diagram below. (Side B is facing up) However, it may be freely installed in any direction forward or back, and to the sides.
- Be sure to leave a 600mm square opening for service and inspection as shown in the diagram below, for both ceiling - suspended installation and wall-mounted installation.
- This unit "does not require drain treatment" as it uses internal foam treatment as low-pressure piping insulation.
- Service direction is the side B and C
- The piping for the indoor unit may be led around in direction A
- The inclination of side B must be within ± 5 degrees forward or back or to the sides.

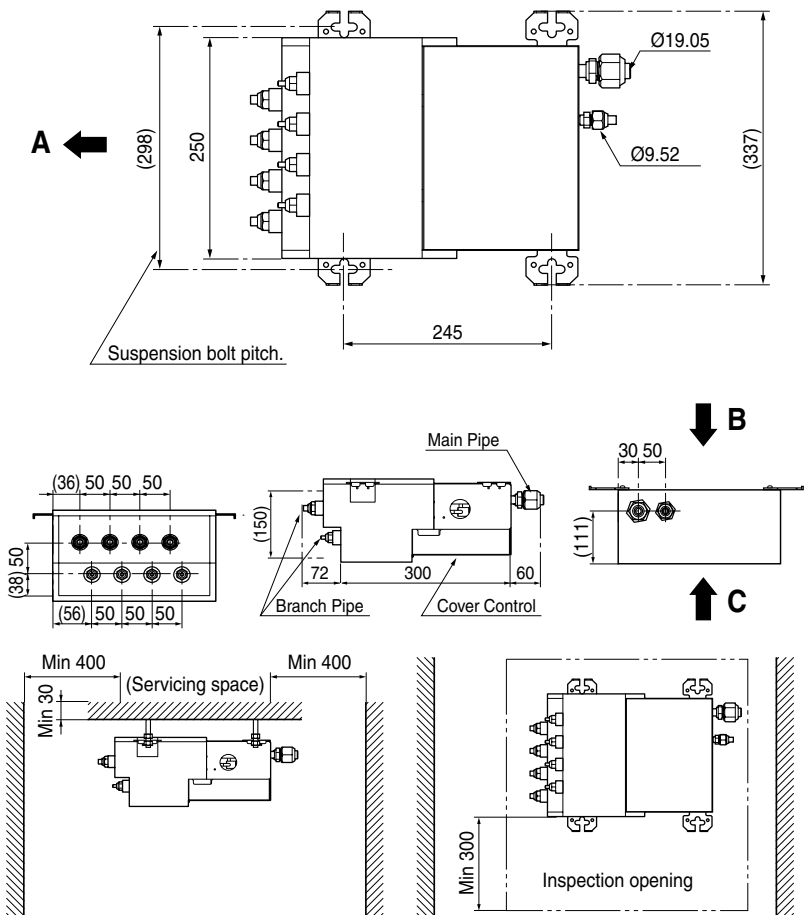

Installation of The Main Unit

NOTICE :

- This unit has two different installation types: (1) Ceiling-suspended type and (2) wall-mounted type.
- Choose the proper installation pattern according to the location of installation.
- The installation location for printed wiring board can be changed.
Follow the procedure specified in the "CONNECTING THE WIRING" section to change the location.

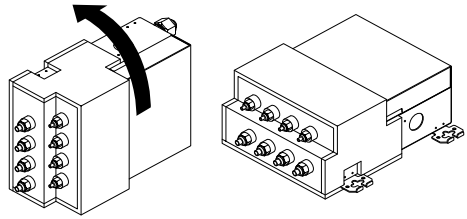

(1) Ceiling-suspended type

(2) Wall-mountde type

(1) Ceiling-suspended type

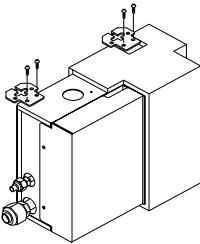
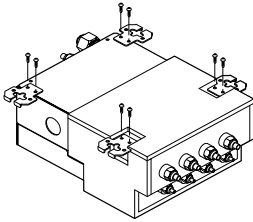

(2) Wall-mounted type

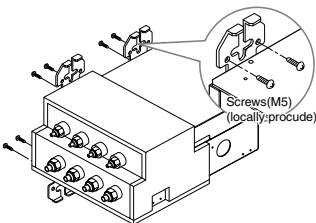

Procedure

- (1) Fix the furnished hanger metal with two screws.(4 locations in total).
- (2) Using an insert-hole-in- anchor, hang the hanging bolt.
- (3) Install a hexagon nut and a flat washer (locally-procured)to the hanging bolt as shown in the figure in the left, and lift the main unit to hang on the hanger metal.
- (4) After checking with a level that the unit is level, tighten the hexagon nut.
* The tilt of the unit should be within $\pm 5^\circ$ in front/back and left/right.

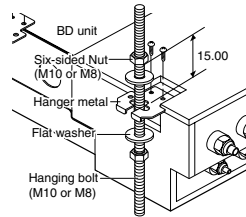

Procedure

- (1) Fix the furnished hanger metal with two screws.
(3 locations in total).
- (2) After checking with a level that the unit is level, fix the unit with the furnished wood screws.
* The tilt of the unit should be within $\pm 5^\circ$ in front/back and left/right.
* Block up the parts of hanger holes (2 places) by using insulation PE after installing the hanger.



CAUTIONS

- Once a screw-hole on the main unit has had a screw hammered in, make sure to either hammer it again or cover it with alumium tape.(This is to prevent condensation)
- Be sure to install the unit with the ceiling-side up.
- Do not install near bedrooms. the sound of refrigerant flowing through the piping may sometimes be audible.

Connecting the Cable between Indoor Unit and Outdoor Unit

Connect the cable to the Indoor unit.

Connect the cable to the indoor unit by connecting the wires to the terminals on the control board individually according to the outdoor unit connection. (Ensure that the color of the wires of the outdoor unit and the terminal No. are the same as those of the indoor unit.)

The earth wire should be longer than the common wires.

The circuit diagram is not subject to change without notice.

When installing, refer to the circuit diagram behind the panel front of Indoor Unit the wiring diagram on the Control Cover Inside Outdoor Unit.



CAUTION:

- The circuit diagram is not subject to change without notice.
- Be sure to connect wires according to the wiring diagram.
- Connect the wires firmly, so that not to be pulled out easily.
- Connect the wires according to color codes by referring the wiring diagram.



CAUTION: Provide a circuit breaker between power source and the unit as shown below.

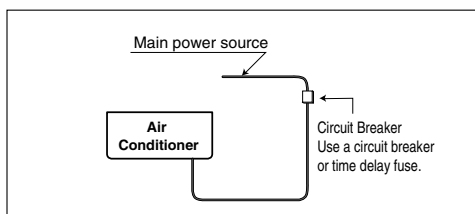

CAUTION: The power cord connected to the outdoor unit should be complied with the following specifications (Cable type approved by HAR or SAA).

Phase	1Ø								3Ø		
	21	24	27	30	40	48	56	42	48	54	
Capacity (kBTu/h)											
NORMAL CROSS SECTIONAL AREA	1.5	2.5	2.5	2.5	3.5	4.0	4.0	2.5	2.5	2.5	
Cable Type	H07RN-F										

(mm²)

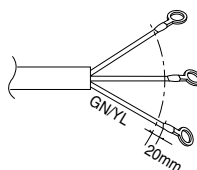

The power connecting cable connected to the indoor and outdoor unit should be complied with the following specifications (Type "B" approved by HAR or SAA).

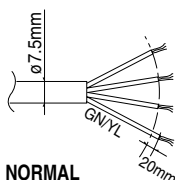

NORMAL CROSS-SECTIONAL AREA 0.75mm²
H07RN-F

Connect the cable to the Outdoor unit.

1. Remove the cover control from the unit by loosening the screw.
Connect the wires to the terminals on the control board individually as the following.
2. Secure the cable onto the control board with the holder (clamper).
3. Refix the cover control to the original position with the screw.
4. Use a recognized circuit breaker between the power source and the unit. A disconnection device to adequately disconnect all supply lines must be fitted.

10 Models

Capacity (kBTu/h)	21	24	27	30	40	48	56
Circuit Breaker (A)	20	25	25	25	30	40	40

30 Models

Capacity (kBTu/h)	42	48	54
Circuit Breaker (A)	25	25	25

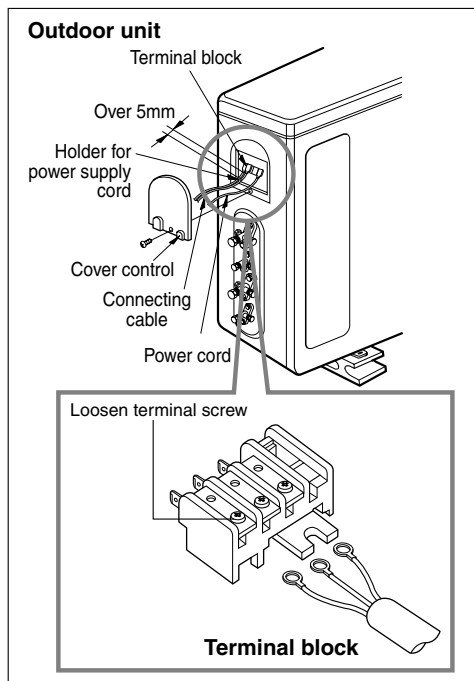

CAUTION: After the confirmation of the above conditions, prepare the wiring as follows.

1. Never fail to have an individual power circuit specifically for the air conditioner. As for the method of wiring, be guided by the circuit diagram posted on the inside of control cover.
2. Firmly tighten the terminal screws to prevent them loosening. After tightening, pull the wires lightly to confirm that they do not move. (If they are loose the unit, the unit will not operate normally or it can cause burn-out of the wires.)
3. Specification of power source.
4. Confirm that electrical capacity is sufficient.
5. See to that the starting voltage is maintained at more than 90 percent of the rated voltage marked on the name plate.
6. Confirm that the cable thickness is as specified in the power source specification. (Particularly note the relation between cable length and thickness.)
7. Do not install an earth leakage circuit breaker in a wet or moist area.
8. The following would be caused by voltage drop.
 - Vibration of a magnetic switch, which will damage the contact point, fuse breaking, disturbance of the normal function of the overload.
9. The means for disconnection from a power supply shall be incorporated in the fixed wiring and have an air gap contact separation of at least 3mm in each active(phase) conductors.

Connection of Wiring

- Connect refrigerant pipes and connection wires to the appropriate ports marked with matching alphabets (A, B and C) on this unit.
- Follow the instructions on the wiring nameplate to connect the connection wires of indoor/outdoor units to terminal board numbers.(1, 2 and 3) Always fix each ground wire separately with a ground screw.(See the figure below.)
- After completing the wiring, fix the outer coating of wires securely with wire clamps. The wire clamp on indoor unit side is furnished. Follow the procedure below to install.
- Refer to the circuit diagram on the control cover inside outdoor unit.

NOTICE :
The terminal board numbers are arranged from top to bottom in order of 1, 2 and 3.

In Case of 3 rooms

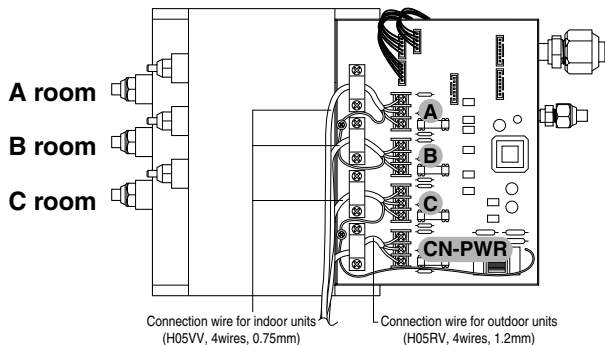

Warning
 Do not use tapped wires, stand wires, extensioncords, or starbust connections, as they may cause overheating, electrical shock, or fire.

- (1) Remove the control cover. Loosen the two screws, and slide the cover in the direction of the arrow.

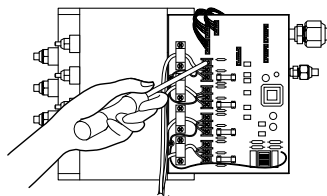
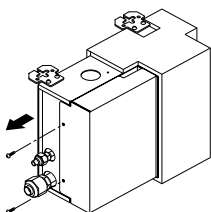

- (3) Put in the cover in the direction of the arrow then tighten the screws.

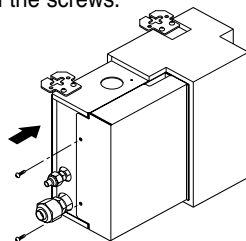

- (2) Perform wiring with reference the wiring diagram on a control cover of outdoor unit. Allow 300 mm for the pulling-out section of harness. Fix the wires completely with wire clamps(4 locations).

Checking the Drainage, Forming the Pippings and Long Pipe Setting

Checking the drainage

To check the drainage.

1. Pour a glass of water on the evaporator.
2. Ensure the water flows through the drain hose of the indoor unit without any leakage and goes out the drain exit.

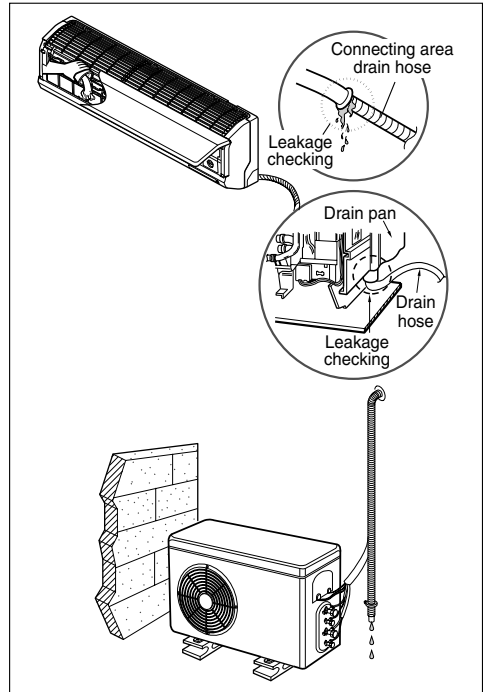

Drain piping

1. The drain hose should point downward for easy drain flow.

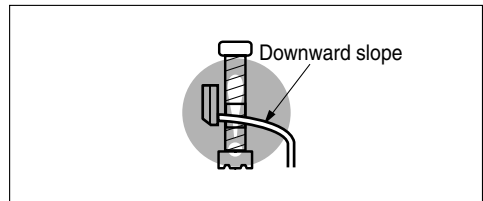

2. Do not make drain piping.

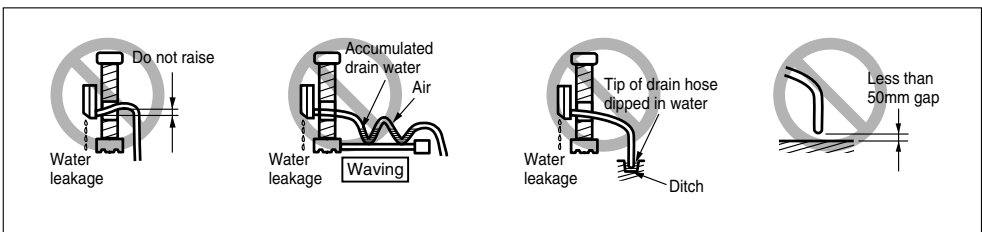

Forming the piping

Form the piping by wrapping the connecting portion of the indoor unit with insulation material and secure it with two kinds of vinyl tape.

- If you want to connect an additional drain hose, the end of the drain outlet should be routed above the ground. Secure the drain hose appropriately.

In cases where the outdoor unit is installed below the indoor unit perform the following.

1. Tape the piping, drain hose and connecting cable from down to up.
2. Secure the taped piping along the exterior wall using saddle or equivalent.

In cases where the Outdoor unit is installed above the Indoor unit perform the following.

1. Tape the piping and connecting cable from down to up.
2. Secure the taped piping along the exterior wall. Form a trap to prevent water entering the room.
3. Fix the piping onto the wall by saddle or equivalent.

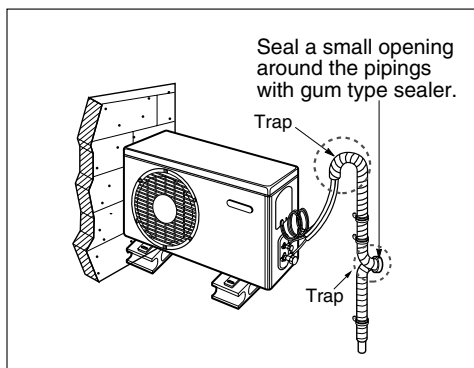
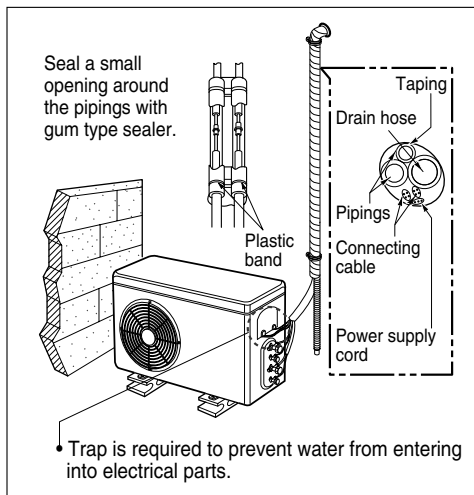

Long Pipe Setting

1. Open the top cover of outdoor unit.
2. Select one of the two selectable modes as follows.
3. Set the Zone as shown in Fig.
4. Close the top cover and check whether the product works normally.

! WARNING: Do not open the top cover or Set the pipe length when operating the product.

**A3UW216FA3
A4UW246FA3**

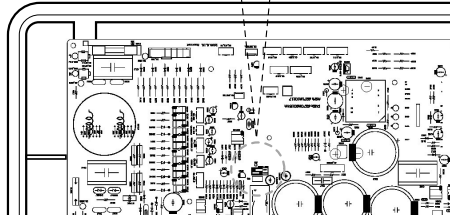
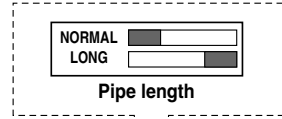

**A4UW276FA3
A5UW306FA3
A5UW406FA3
A7UW406FA3**

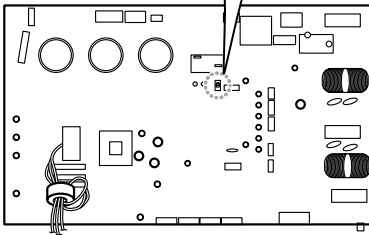
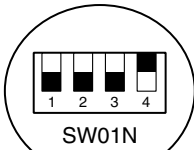

**A8UW486FA3
A9UW566FA3
A7UW428FA3
A8UW488FA3
A9UW548FA3**

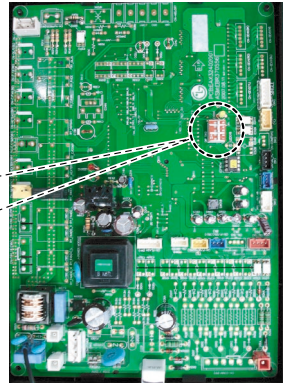
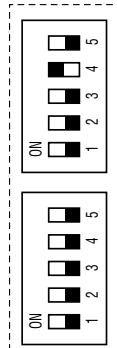

Air Purging and Evacuation

Air and moisture remaining in the refrigerant system have undesirable effects as indicated below.

1. Pressure in the system rises.
 2. Operating current rises.
 3. Cooling(or heating) efficiency drops.
 4. Moisture in the refrigerant circuit may freeze and block capillary tubing.
 5. Water may lead to corrosion of parts in the refrigeration system.
- Therefore, the indoor/outdoor unit and connecting tube must be checked for leak tight, and vacuumed to remove incondensable gas and moisture in the system.

Checking method

Preparation

- Check that each tube(both liquid and gas side tubes) between the indoor and outdoor units have been properly connected and all wiring for the test run has been completed. Remove the service valve caps from both the gas and the liquid side on the outdoor unit. Check that both the liquid and the gas side service valves on the outdoor unit are kept closed at this stage.

Leakage test

- Connect the manifold valve(with pressure gauges) and dry nitrogen gas cylinder to this service port with charge hoses.



CAUTION: Be sure to use a manifold valve for leakage test.

If it is not available, use a stop valve for this purpose. The "Hi" knob of the manifold valve must always be kept close.

- Pressurize the system to no more than 150 P.S.I.G. with dry nitrogen gas and close the cylinder valve when the gauge reading reached 150 P.S.I.G. Next, test for leaks with liquid soap.



CAUTION: To avoid nitrogen entering the refrigerant system in a liquid state, the top of the cylinder must be higher than its bottom when you pressurize the system. Usually, the cylinder is used in a vertical standing position.

1. Do a leakage test of all joints of the tubing(both indoor and outdoor) and both gas and liquid side service valves. Bubbles indicate a leak. Be sure to wipe off the soap with a clean cloth.
2. After the system is found to be free of leaks, relieve the nitrogen pressure by loosening the charge hose connector at the nitrogen cylinder. When the system pressure is reduced to normal, disconnect the hose from the cylinder.

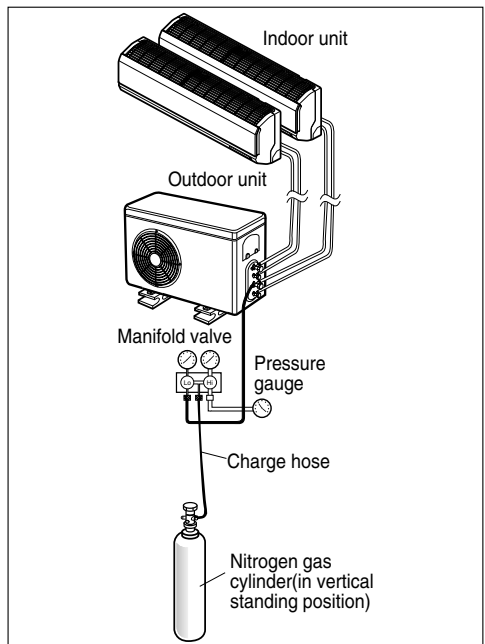

Soap water method

1. Remove the caps from the 2-way and 3-way valves.
2. Remove the service-port cap from the 3-way valve.
3. To open the 2-way valve turn the valve stem counterclockwise approximately 90°, wait for about 2~3 sec, and close it.
4. Apply a soap water or a liquid neutral detergent on the indoor unit connection or outdoor unit connections by a soft brush to check for leakage of the connecting points of the piping.
5. If bubbles come out, the pipes have leakage

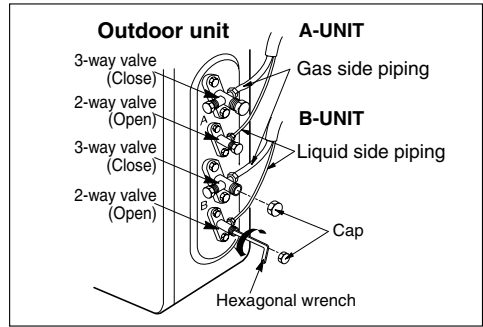

Evacuation

1. Connect the charge hose end described in the preceding steps to the vacuum pump to evacuate the tubing and indoor unit. Confirm the "Lo" knob of the manifold valve is open. Then, run the vacuum pump. The operation time for evacuation varies with tubing length and capacity of the pump. The following table shows the time required for evacuation.

Required time for evacuation when 30 gal/h vacuum pump is used	
If tubing length is less than 10m (33ft)	If tubing length is longer than 10m (33ft)
Less than 0.5 Torr	Less than 0.5 Torr

2. When the desired vacuum is reached, close the "Lo" knob of the manifold valve and stop the vacuum pump.

Finishing the job

1. With a service valve wrench, turn the valve stem of liquid side valve counter-clockwise to fully open the valve.
2. Turn the valve stem of gas side valve counter-clockwise to fully open the valve.
3. Loosen the charge hose connected to the gas side service port slightly to release the pressure, then remove the hose.
4. Replace the flare nut and its bonnet on the gas side service port and fasten the flare nut securely with an adjustable wrench. This process is very important to prevent leakage from the system.
5. Replace the valve caps at both gas and liquid side service valves and fasten them tight.

This completes air purging with a vacuum pump. The air conditioner is now ready to test run.

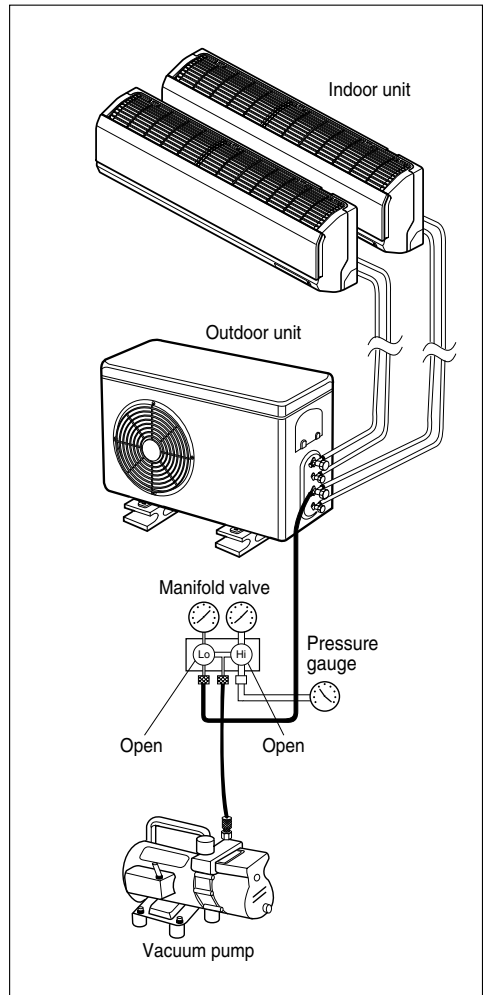

Panel Front Assembly (ART COOL type Only)

1. First, Check the side cover assembly exactly, Fix power cord in the bottom groove of cover side left.

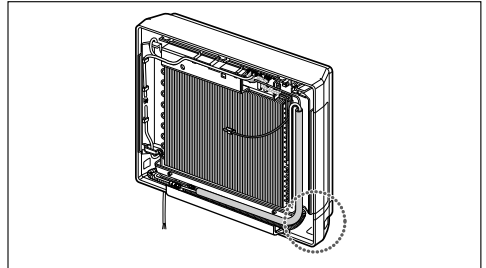

2. Assemble connecting lead wire with controller and first fix the upper part of panel front, then match the lower part of panel front

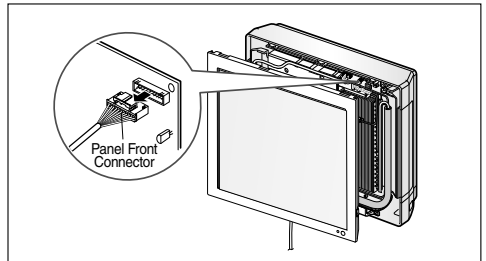
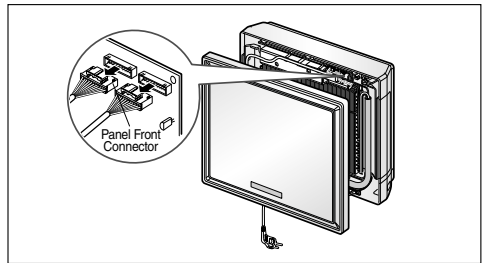

3. Suspend hook of front panel in the groove after contract lower of 2 screws.

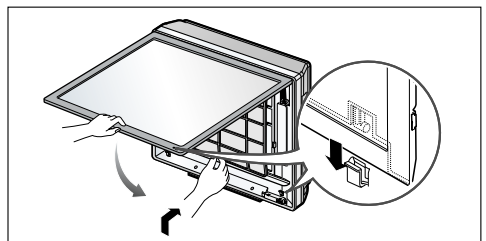
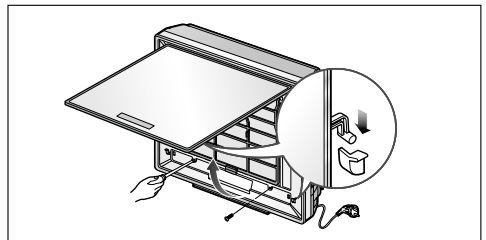

Installation PI485

- Fix the PI485 PCB as shown in Fig.

Detailed installation method refer to PI485 Installation Manual.

A3UW216FA3

A4UW246FA3

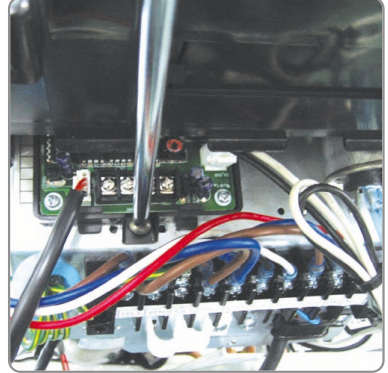
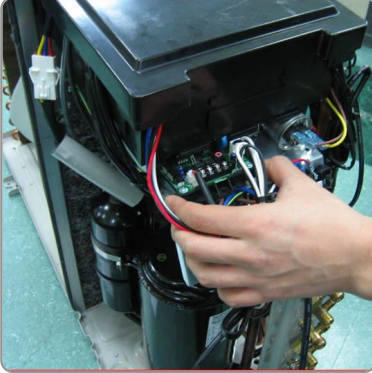

A4UW276FA3

A5UW306FA3

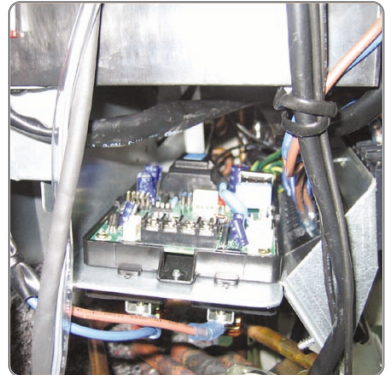
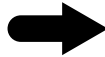
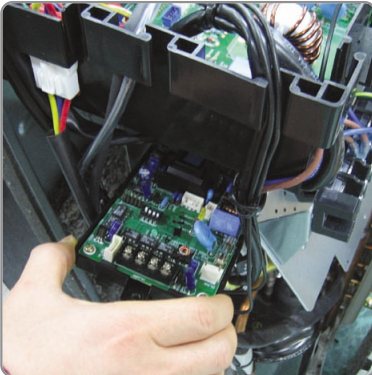

A5UW406FA3
A7UW406FA3

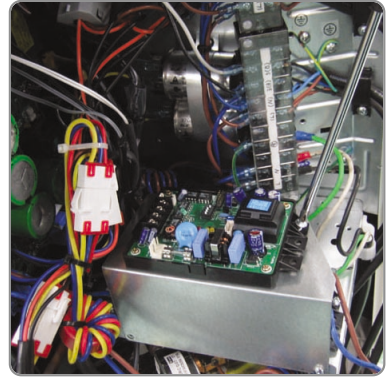
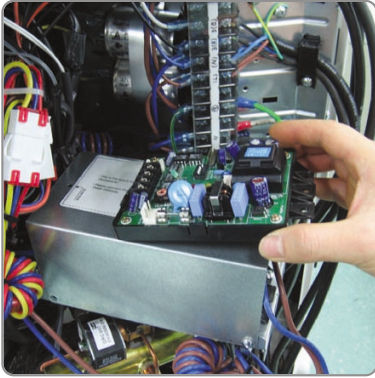

A8UW486FA3
A9UW566FA3
A7UW428FA3
A8UW488FA3
A9UW548FA3

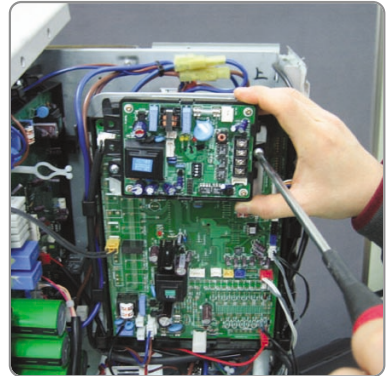
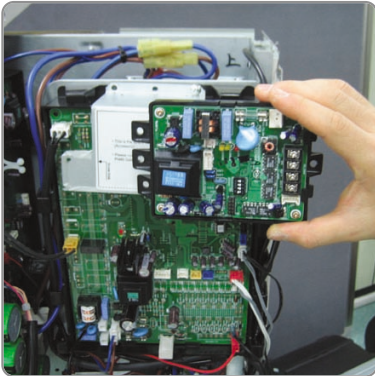

Test Running

1. Check that all tubing and wiring have been properly connected.
2. Check that the gas and liquid side service valves are fully open.

Prepare remote control

Remove the battery cover by pulling it according to the arrow direction.

Insert new batteries making sure that the (+) and (-) of battery are installed correctly.

Reattach the cover by pushing it back into position.

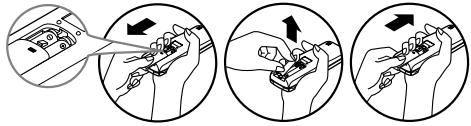

NOTICE :

- Use 2 AAA(1.5volt) batteries. Do not use rechargeable batteries.
- Remove the batteries from the remote control if the system is not going to be used for a long time.

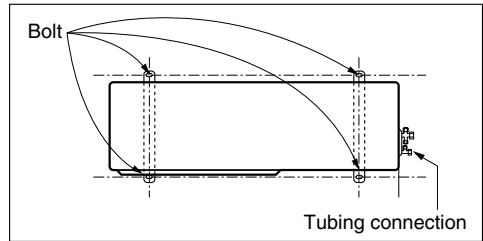

Evaluation of the performance

Operate unit for 15~20 minutes, then check the system refrigerant charge:

1. Measure the pressure of the gas side service valve.
2. Measure the temperature of the intake and discharge of air.
3. Ensure the difference between the intake temperature and the discharge is more than 8°C
4. For reference, the gas side pressure of optimum condition is as below.(Cooling)

Refrigerant	Outside ambient TEMP.	The pressure of the gas side service valve.
R410A	35°C (95°F)	8.5~9.5kg/cm ² G(120~135 P.S.I.G.)

- NOTICE :** If the actual pressure are higher than shown, the system is most likely overcharged, and charge should be removed. If the actual pressure are lower than shown, the system is most likely undercharged, and charge should be added.
- The air conditioner is now ready for use.

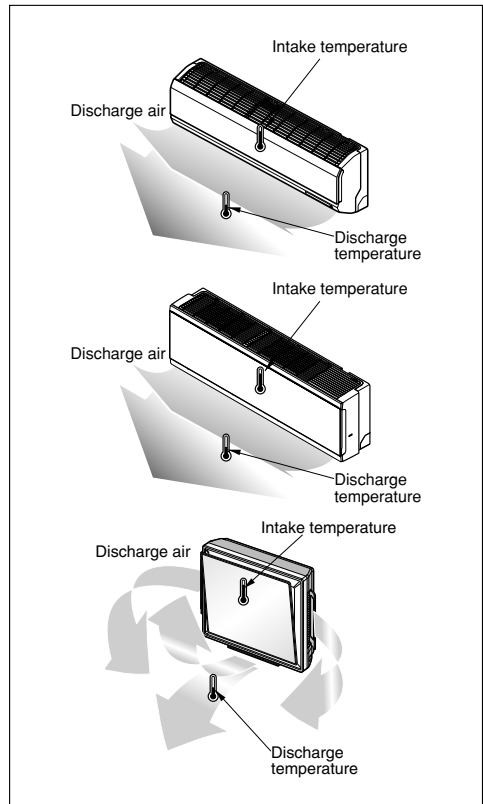

Combination indoor units

The indoor units connectable to the outdoor unit are shown below.

Type	Chassis Name	Model Name				
		Capacity, kBtu/h				
		7	9	12	18	24
Wall mounted	S4					
	S5					
ART COOL	SF					
ART COOL Deluxe	SZ					
	SU					
	S3					
	SE					
	S8					
Ceiling Cassette1Way	TC1					
Ceiling Cassette 4Way	TE1					
	TH					
Ceiling concealed Duct (High Static)	BH					
Ceiling concealed Duct (Low Static)	B1					
	B2					
Ceiling concealed Duct (Built In)	BP					
Ceiling & Floor	VE					
	VB					

- NOTICE** :
1. The total capacity(in kBtu/h unit) of connected indoor unit models represents the total sum of the figures expressed in the indoor model name.
 2. Combinations in which the total capacity of the connected indoor units exceeds the capacity of the outdoor unit will reduce the capacity of each indoor unit below the rated capacity during simultaneous operation. Therefore, if circumstances allows, combine indoor units within the capacity of the outdoor unit

Max Combination Capacity

Multi Piping Type

Capacity (kBtu/h)	Max Room No.	Combination Indoor Capacity (kBtu/h)	Max Combination Capacity (kBtu/h)
21	3	7, 9, 12, 18	33
24	4	7, 9, 12, 18, 24	40
27	4	7, 9, 12, 18, 24	43
30	5	7, 9, 12, 18, 24	48
40	5	7, 9, 12, 18, 24	52

Distributor Type

Phase	Capacity (kBtu/h)	Max Room No.	Combination Indoor Capacity (kBtu/h)	Combination Capacity Range (kBtu/h)
1Ø	40	7	7, 9, 12, 18, 24	16~52
	48	8	7, 9, 12, 18, 24	19~63
	56	9	7, 9, 12, 18, 24	22~73
3Ø	42	7	7, 9, 12, 18, 24	17~54
	48	8	7, 9, 12, 18, 24	19~62
	54	9	7, 9, 12, 18, 24	22~73

The combination of indoor unit is to be decided that the sum of indoor unit capacity index must be smaller than the maximum combination capacity of outdoor unit. We recommend to calculate indoor unit capacity like below.

If you do not follow our recommendation, it will have some problems in low ambient condition i.e. some indoor unit will not be able to heat very well in heating mode.

CALCULATION METHOD FOR THE CONNECTABLE TOTAL CAPACITY OF INDOOR UNIT

Sum up the capacity of all indoor unit, but **high static duct type indoor unit** capacity weights **1.3 times**

- Ex) 1. Outdoor unit : A9UW566FA3(FM56AH)(connectable maximum capacity is 73kBtu)
 Indoor unit: AMNH186BHA0[MB18AH],AMNH246BHA0[MB24AH],AMNH246BHA0[MB24AH]
 $(18 + 24 + 24) \times 1.3 = 66 \times 1.3 = 85.8\text{kBtu}$: this combination has a some problem
2. Out door unit: FM56AH
 Indoor unit: AMNH186BHA0[MB18AH],AMNH246BHA0[MB24AH],AMNH18GD5L0[MS18AH]
 $(18 + 24) \times 1.3 + 18 + 72.6$: this combination can be ok

Installation guide at the seaside

CAUTION

1. Air conditioners should not be installed in areas where corrosive gases, such as acid or alkaline gas, are produced.
2. Do not install the product where it could be exposed to sea wind (salty wind) directly. It can result corrosion on the product. Corrosion, particularly on the condenser and evaporator fins, could cause product malfunction or inefficient performance.
3. If outdoor unit is installed close to the seaside, it should avoid direct exposure to the sea wind. Otherwise it needs additional anticorrosion treatment on the heat exchanger.

Selecting the location(Outdoor Unit)

- 1) If the outdoor unit is to be installed close to the seaside, direct exposure to the sea wind should be avoided. Install the outdoor unit on the opposite side of the sea wind direction.

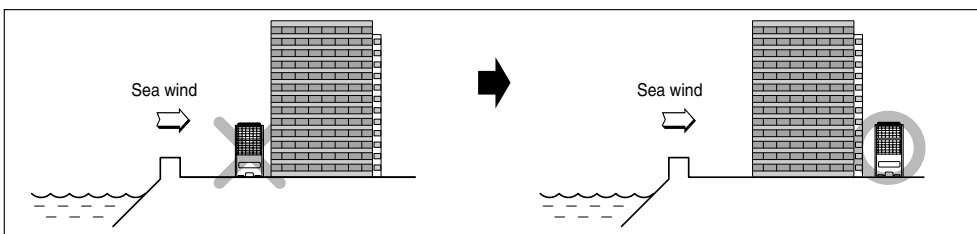

- 2) In case, to install the outdoor unit on the seaside, set up a windbreak not to be exposed to the sea wind.

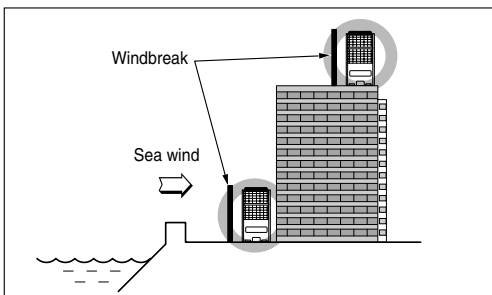

- It should be strong enough like concrete to prevent the sea wind from the sea.
- The height and width should be more than 150% of the outdoor unit.
- It should be keep more than 70 cm of space between outdoor unit and the windbreak for easy air flow.

- 3) Select a well-drained place.

1. If you can't meet above guide line in the seaside installation, please contact LG Electronics for the additional anticorrosion treatment.
2. Periodic (more than once/year) cleaning of the dust or salt particles stuck on the heat exchanger by using water

