



VCP OWNER'S MANUAL

MODEL: W141W



Before connecting, operating, or adjusting this product, please read this instruction booklet carefully and completely.

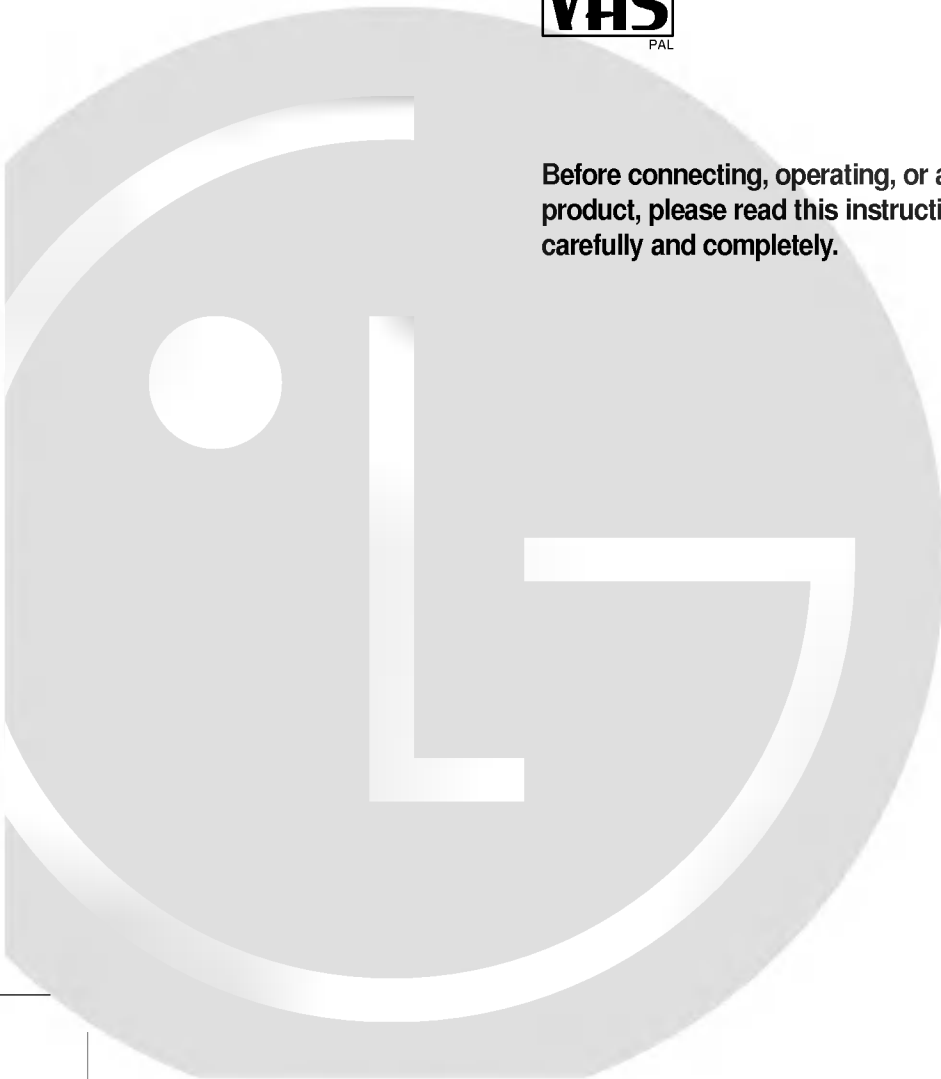

SAFETY PRECAUTION

THIS EQUIPMENT MUST BE DISCONNECTED FROM THE MAINS POWER SUPPLY WHEN IT IS NOT IN USE. DO NOT ALLOW THIS UNIT TO BE EXPOSED TO RAIN OR MOISTURE.

CAUTION

TO PREVENT ELECTRIC SHOCK, DO NOT REMOVE THE COVER. NO USER SERVICEABLE PARTS ARE INSIDE. REFER SERVICING TO QUALIFIED PERSONNEL.

WARNING

THE RECORDING AND PLAYBACK OF CERTAIN MATERIAL MAY NOT BE DONE WITHOUT PERMISSION.

MOISTURE CONDENSATION

If you pour a cold liquid into a glass, water vapor in the air will condense on the surface of the glass. This is moisture condensation. Moisture condensation on the head drum, one of the most crucial parts of the unit, will cause damage to the tape. When the VCP is exposed to a rapid temperature change from cold to warm, some condensation will occur. Under this condition, connect the power cord to the AC line, press **OPERATE** button on and allow at least two hours for the VCP to dry out.

Condensation is likely to occur when

1. The video unit is moved from a cold room to a warm room or from outdoors to inside your home.
2. A cold room is heated quickly.
3. The humidity is very high.

PRECAUTIONS

Please read these precautions before you operate this unit.

- Avoid extreme heat, cold, moisture and dust.
- Avoid using near a magnetic field.
(This will adversely affect the units performance.)
- Be careful when the surface of the case is wiped with a volatile agent such as benzene, alcohol, thinner, etc. or a chemically processed cloth, the surface finish may deteriorate or its coating may peel.
- Use the unit only in a horizontal position, and do not place anything heavy on it.
- Keep the unit away from flower vases, tubs, sinks, etc. If any liquids should spill into unit, serious damage could occur. In that case, please consult qualified service personnel.
- Do not obstruct the ventilation holes: they prevent overheating. Even soft materials such as paper and cloth may prevent proper ventilation of the unit.

CONTENTS

INTRODUCTION2-5

 REMOTE CONTROL.....3

 FRONT VIEW4

 REAR VIEW.....5

 VIDEO CHANNEL SETTING.....5

PREPARATION6-8

 INSTALLATION.....6

 DC POWER SOURCE7

 THE VIDEO CASSETTE8

PLAYBACK.....9-11

 NORMAL PLAYBACK.....9

 PLAYBACK VARIATIONS (SPECIAL EFFECTS).....10-11

RECORDING12

ADDITIONAL INFORMATION.....13-14

 ON SCREEN DISPLAY13

 BEFORE REQUESTING SERVICE14

 SPECIFICATIONS14

FEATURES

- PAL B/G, SECAM D/K DUAL SYSTEM
- AUTO VOLTAGE SYSTEM (AC 100 - 240V)
- AUTO HEAD CLEANING
- CONVENIENT AUTOMATIC FUNCTIONS
- QUICK START PLAYBACK FUNCTION
- VISUAL SEARCH FUNCTION
- JET SEARCH FUNCTION
- LOGIC SEARCH FUNCTION
- FREEZE FUNCTION (STILL), STILL-SLOW EFFECT
- FRAME ADVANCE FUNCTION
- AUTOMATIC REPEAT PLAYBACK
- HQ; HIGH QUALITY PICTURE ENHANCEMENT SYSTEM
- FUNCTION ON SCREEN DISPLAY
- TAPE COUNTER DISPLAY
- NTSC PLAYBACK ON PAL TV

REMOTE CONTROL

You can control almost all the functions of the VCP with the wireless remote control. The Remote Control must have "Line of Sight" to the Remote Sensor on the front of the VCP. It must be within an angle of 30 degrees either side of centre. The maximum operating distance is about 25 feet.

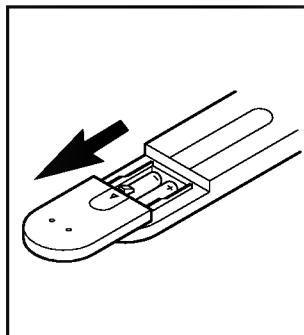
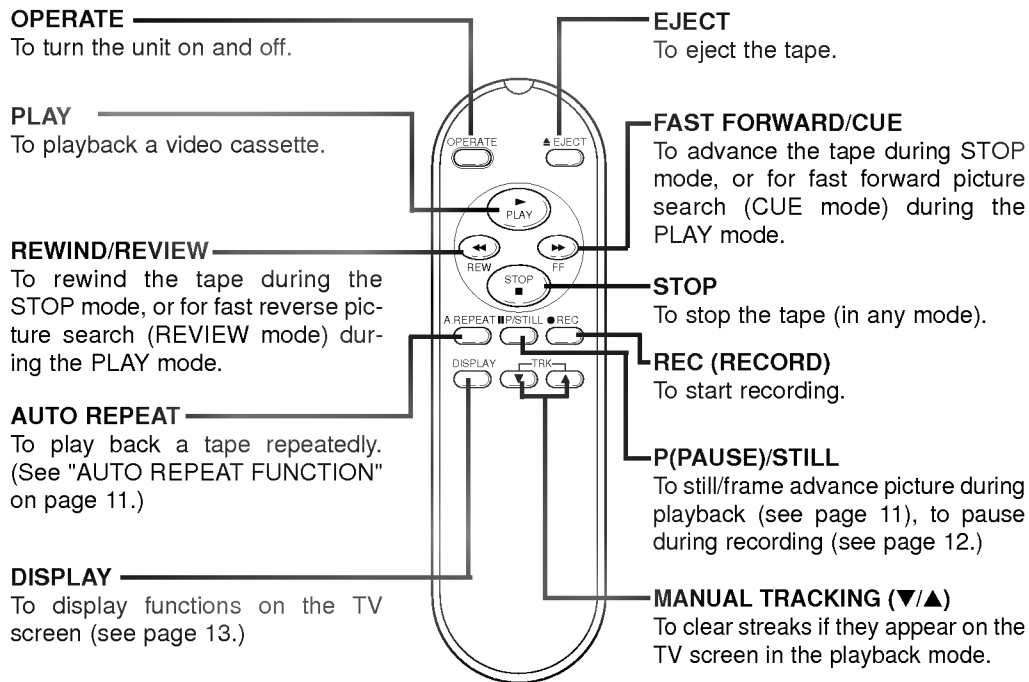

OPERATION OF REMOTE CONTROL

Aim the remote control unit at the sensor on the front panel of the VCP.

HOW TO INSTALL THE BATTERIES

- 1 Slide the battery compartment cover in the direction of arrow.
- 2 Insert 2 "AAA"-size batteries in the correct direction.
- 3 Replace the cover.

- ◆ If the range is short, try new batteries.
- ◆ An object between the VCP and remote control unit may block the invisible light beam and operation will be impossible.
- ◆ Batteries installed backwards may leak and damage your Remote Control.
- ◆ Do not mix old and new batteries or carbon types with alkaline types.
- ◆ Remove the batteries from the battery compartment if the remote control will not be used for a long time.

FRONT VIEW

REMOTE SENSOR WINDOW
Receives infrared rays from remote control unit.

OPERATE and INDICATOR
To turn the unit on and off. When this button is pressed to ON, the OPERATE indicator lights.

FUNCTION INDICATORS
Indicates the status of this unit.

CASSETTE COMPARTMENT
Insert a cassette in the compartment.

PLAY
To playback a video cassette.

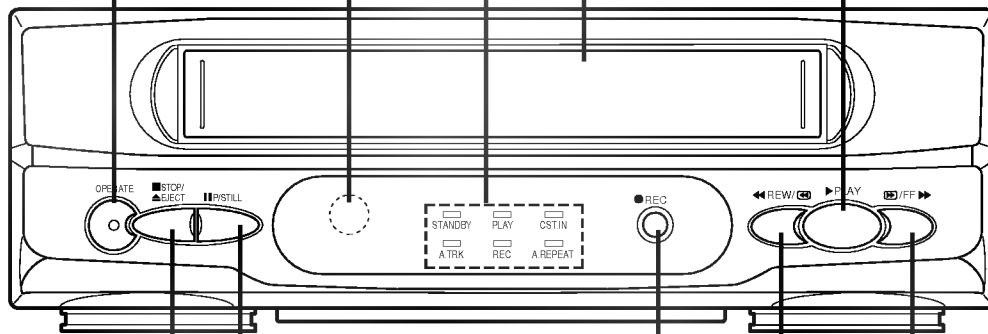

STOP/EJECT
To stop or eject the tape.

P(PAUSE)/STILL
To still playback, pause recording.

REC (RECORD)
To start recording.

REWIND/REVIEW
To rewind the tape or for fast reverse picture search.

FAST FORWARD/CUE
To advance the tape, or for fast forward picture search.

REAR VIEW

AERIAL IN TERMINAL

Connect the external antenna to this terminal.

RF CHANNEL CONTROL

Turn this control to set the video channel (CH32-CH40) correctly (whichever is not being used in your area).

RF OUT ANTENNA TERMINAL

Connect this terminal to the AERIAL antenna terminal on the back of the TV.

K/G SELECT SWITCH

Set this K/G select switch K or G position, depending on the type of PAL colour system used for TV broadcasting in your area.

AUDIO OUT JACK; Connect this terminal to the audio input terminal on an external unit (Audio System, TV/Monitor, Another VCR).

VIDEO OUT JACK; Connect this terminal to the video input terminal on an external unit (TV/Monitor, Another VCR).

AUDIO IN JACK; Connect the audio output cable from an external unit (Audio System, TV/Monitor, Another VCR) to this terminal.

VIDEO IN JACK; Connect the video output cable from an external unit (TV/Monitor, Another VCR) to this terminal.

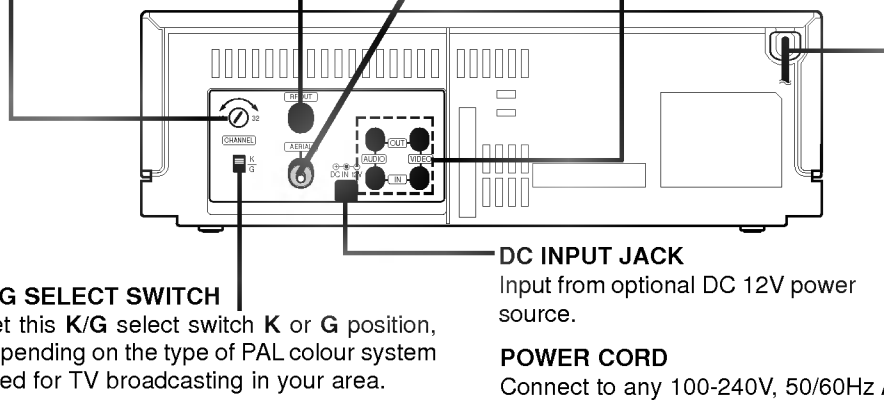

DC INPUT JACK

Input from optional DC 12V power source.

POWER CORD

Connect to any 100-240V, 50/60Hz AC outlet.

VIDEO CHANNEL SETTING

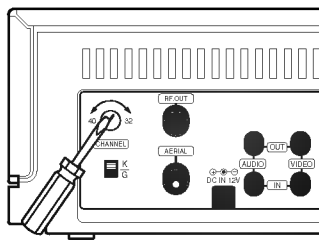

If this unit is connected to the TV via the supplied coaxial connector cable, the video channel will have to be set. (see page 6)

Setting the video channel with playback

- 1 The output channel of the VCP is set at UHF channel 36.
- 2 Turn on the TV set and the VCP.
- 3 Set the K/G select switch to match your area's TV system.
- 4 Insert a pre-recorded cassette and begin playback.
- 5 Select the correct channel (36) on your TV set. And then you will see the picture being played in VCP.

If you connect a monitor or a TV set equipped with audio and video sockets, this adjustment will not be necessary. Consult the operating instructions of your TV set.

Changing the transmitter channel

If channel 36 is already occupied at your TV set, or if the picture is distorted, you can change the transmitter channel of the VCP. Select an undistorted channel between 32 and 40 on your TV set and store it. Use a small screwdriver to turn slowly the **CHANNEL** control on the rear of the VCP, until you are satisfied with the picture quality.

INSTALLATION

CONNECTION (AERIAL)

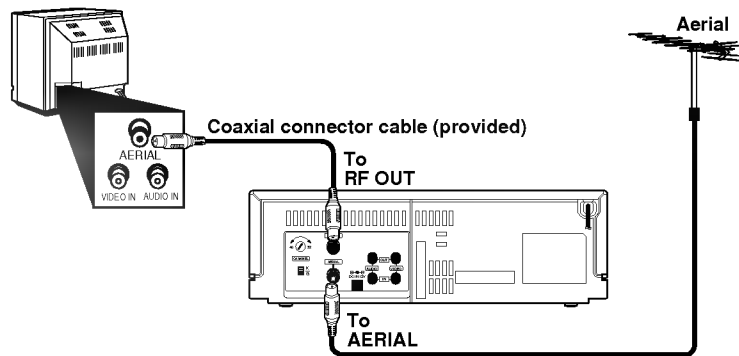

- 1 Remove the coaxial aerial cable from your TV set. Place this cable into the terminal marked "AERIAL" on the VCP.
- 2 Connect the aerial terminal on your TV set to the RF Output Socket on the VCP with the supplied coaxial connector cable.
- 3 Plug into the AC outlet.

TV viewing while the VCP is connected as shown.

To watch a normal TV broadcast, turn the VCP off and select a TV station with the TV's channel selector.

CONNECTION (AV)

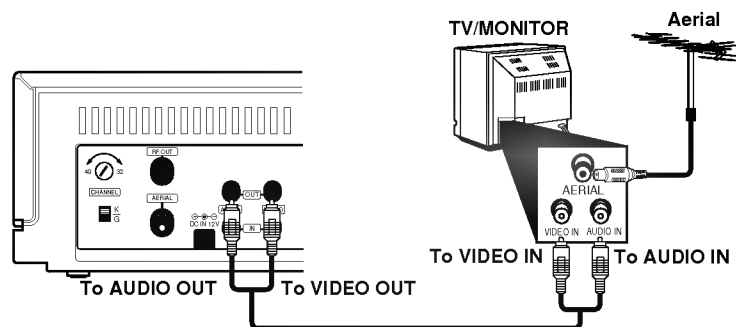

The advantage of this connection is a superior quality of picture and sound during playback.

- 1 Connect the VCP to a TV with AUDIO/VIDEO jacks as shown.
- 2 Turn the VCP on.
- 3 Turn the TV on and select the VIDEO position of TV's TV/VIDEO select button.

TV viewing while the VCP is connected as shown.

Select the TV position of TV's TV/VIDEO select button.

DC POWER SOURCE

The VCP is designed for in-home or portable use. You can power it from standard AC adaptor, from the cigarette lighter socket in your vehicle, or a 12V DC power source.

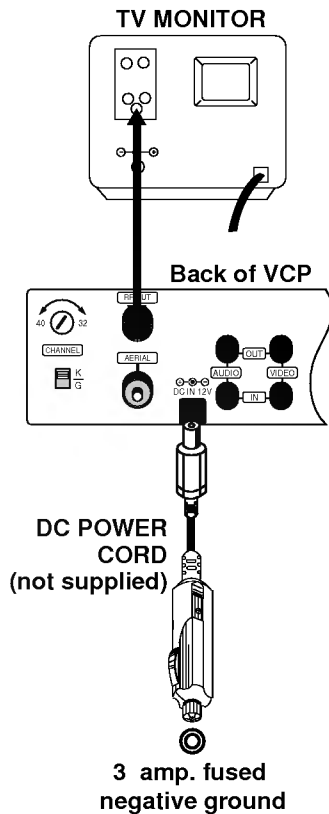

DC INPUT JACK

Plug this adaptor into either the 12 volt DC outlet or cigarette lighter socket. Plug the small plug into the DC input jack on the VCP.

WARNING: When the unit is not in use, always disconnect it from the car cigarette lighter socket to avoid battery drain.

Do not leave the unit in a place where the temperature exceeds 70°C (158°F), or the pickup device may be damaged. Examples include:

- Inside a car with the windows closed and in direct sunshine.
- Near a heating appliance.

CAUTIONS

- The VCP and its DC power cord are designed for use in vehicles that have 12-volt, negative ground electrical systems. (This is standard for most vehicles.) If your vehicle has a different type of electrical system, the DC power system can not be used.
- To prevent electrical shock and possible damage to your VCP or vehicle, always unplug the power cord from the cigarette lighter socket before you remove the plug from the VCP.
- A 3 amp. 125 or 250V fuse for protection is installed in the adaptor.
- While the engine is being started, disconnect the DC plug from the car's cigarette lighter socket.
- Do not operate the VCP when the car battery is discharged. Peak current from the car generator may cause the DC fuse to blow.
- If the vehicle's supply voltage drops below approximately 10 volts, the unit may not work properly.

THE VIDEO CASSETTE

PREPARATION

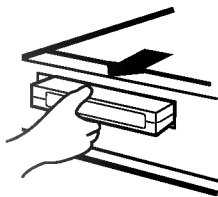
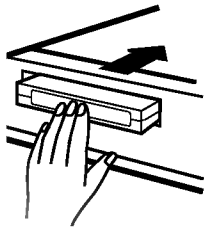

LOADING

Insert the video cassette with the window side up and the label facing you. Press the middle of the tape slowly.

UNLOADING

Press the **STOP/EJECT** (or **EJECT**) button in the STOP mode. The cassette compartment will open and the video cassette will automatically be partially ejected. The cassette may also be ejected without engaging **POWER ON** as long as the VCP is connected to the wall outlet.

When the VCP is not in use...

Make sure you rewind and remove the cassette after each use.

◆ Loading and unloading of the cassette are possible only when the power cord is connected to the wall outlet.

◆ If the cassette has not been seated correctly by the unit, wait a few seconds. The unit will sense the problem and eject the tape.

ACCIDENTAL ERASURE PREVENTION

Cassette has a tab to prevent that recordings are not erased accidentally.

To prevent accidental erasure, break off the tab with a screwdriver.

To record again, cover the hole with cellophane tape.

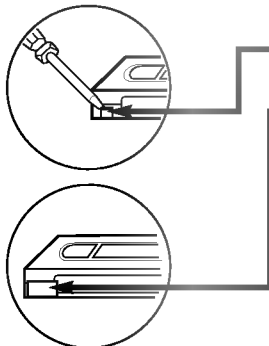

TYPE OF VIDEO CASSETTES

TAPE TYPE	VIDEO CASSETTE LENGTH	MAXIMUM RECORDING/PLAYBACK
PAL & MESECAM	E-240	4 Hrs.
	E-180	3 Hrs.
	E-120	2 Hrs.
	E-90	1 Hr. 30 Mins.
	E-60	1 Hr.
NTSC (Playback only)	T-160	2 Hrs. 40 Mins.
	T-120	2 Hrs.

VIDEO HEAD CLEANING

- Picture playback may become blurred or interrupted even though the TV programme received is clear. This does not mean that the recorded programme has been erased.
- Dirt accumulation on the head after long periods of use can cause these problems. In this case, the heads may require cleaning.
- If high quality video tapes are used in this unit, the video heads should not normally require cleaning, because of the built in automatic head cleaner. However, it is possible that the heads may become clogged when playing an old or damaged tape. If the image on your screen resembles the picture on the left, while playing back a tape, the heads may require cleaning.
- To clean the heads, obtain a head cleaning tape from your local video dealer. Be sure to follow the instructions that come with the cleaning tape, as excessive use can shorten head life.

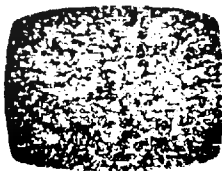

NORMAL PLAYBACK

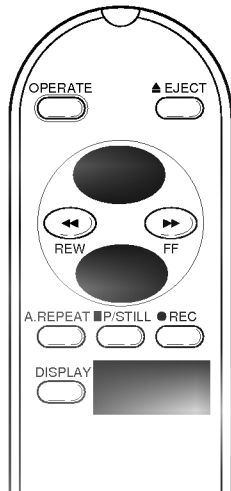

TO START PLAYBACK

- 1 Turn on the TV and set the video channel on your TV, the same as selected on video's RF channel control.
- 2 Insert a pre-recorded video cassette, the VCP is turned on automatically and playback starts automatically. If the cassette has a safety tab, press the **PLAY** button to start playback.
- 3 After viewing the tape, press the **STOP**(or **STOP/EJECT**) button to stop playback. Press the **STOP/EJECT**(or **EJECT**) button to remove the tape.

If the TV set can not hold the NTSC vertical synchronization signal, then the picture will move up and down. The above symptom is not VCP malfunction.

TRACKING ADJUSTMENT

AUTO TRACKING; When playback is started, the auto tracking function operates and adjusts automatically so the picture is optimized.

- During finding the optimum point, A.TRK indicator flickers on the front panel.
- After completing the optimum point, A.TRK indicator is settled on the front panel.

- ◆ *This function will be operated in normal playback mode.*
- ◆ *If you use a poorly recorded tape, the noise level may fail to reach the optimum point. In this case, perform MANUAL TRACKING adjustment as below.*

MANUAL TRACKING; Press **TRACKING** (▼ or ▲) buttons for best picture. May also be used during searching to move the noise bars up or down on the screen.

AUTOMATIC PLAYBACK (FULL AUTO FUNCTION)

You can enjoy the convenient full auto function which is called "AUTO PLAY".

If you insert a cassette tape without a safety tab in place into the VCP, the video programme begins automatically. (Refer to "FULL AUTO FUNCTION" diagram.)

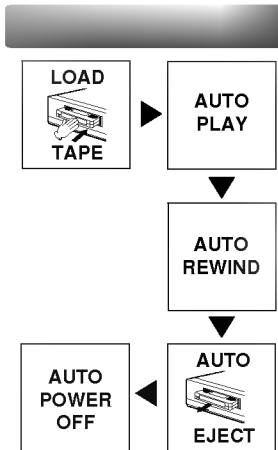

PLAYBACK

PLAYBACK VARIATIONS (SPECIAL EFFECTS)

You can enjoy your playback picture in various playback modes:

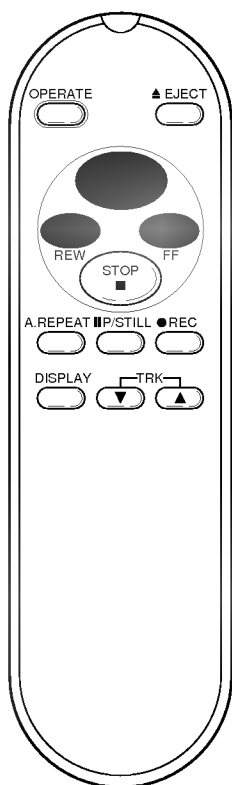

PLAYBACK

VISUAL SEARCH (CUE and REVIEW)

During **PLAYBACK** mode...

- 1 Press the desired search button (**REW** or **FF**) once to begin visual search. The tape will be played back in forward or reverse direction about 7 times (PAL recorded tape)/5 times (NTSC recorded tape) faster than the normal playback speed.
- 2 Press the **PLAY** button to resume normal speed playback.

If the VCP is left in the CUE or REVIEW mode for more than about 3 minutes, the VCP will automatically place itself in the PLAY mode to protect the tape and the video heads.

JET SEARCH (RAPID VISUAL SEARCH)

During the **CUE** or **REVIEW** mode...

- 1 Press and hold search button (**REW** or **FF**) continuously for more than 1 second will be played back the tape in forward or reverse direction about 9 times (PAL recorded tape)/7 times (NTSC recorded tape) faster than the normal playback speed.
- 2 When you have reached the desired point of the tape, release the **REW** or **FF** button so that the VCP enters the normal playback mode.

LOGIC SEARCH

During the **STOP** mode...

- 1 Press search button (**REW** or **FF**) to start rewind or fast forward.
- 2 Press and hold search button (**REW** or **FF**), the picture will be viewed at 7 times (PAL recorded tape)/5 times (NTSC recorded tape) faster than the normal playback speed.
- 3 When you have reached the desired point of the tape, release the search button (**REW** or **FF**) so that the VCP enters fast rewind or fast forward mode.

- ◆ *The audio is automatically muted in this mode, so there is no sound during searching.*
- ◆ *While this function is operating, there may be some "noise streaks" in the TV picture.*

PLAYBACK VARIATIONS (SPECIAL EFFECTS)

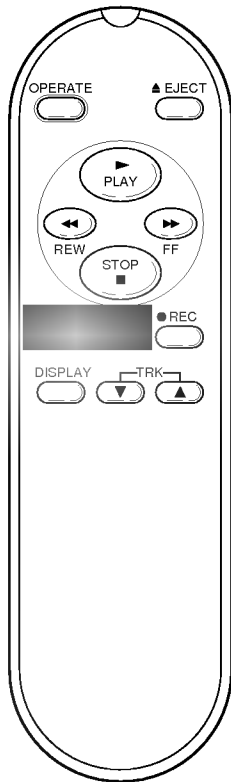

STILL PLAYBACK (FRAME ADVANCE)

- 1 Press the **P/STILL** button to stop the picture on the screen during playback.
- 2 When you press **P/STILL** button during still playback mode, the tape will be played back frame by frame.
 - During still picture playback, if you hold down the **P/STILL** button for more than 1 second and then release, the picture will be changed to slow motion. Press **P/STILL** button again to return to the still mode.
- 3 During still or slow playback, press the **PLAY** button to return to normal playback.

- ◆ The still picture may be unstable or noise bars may appear.
- ◆ During still playback mode, press the **P/STILL** button again to minimize the noise bars and press the **TRACKING** (▼ or ▲) buttons to eliminate the vertical jitters.
- ◆ No sound will be heard.
- ◆ If the unit is left in the **STILL** mode for more than approx. 5 minutes, the unit will automatically place itself in the **STOP** mode to protect the tape and the video heads.

AUTO REPEAT FUNCTION

A tape can be played back repeatedly.

- 1 If you want to play back tape repeatedly, press the **A.REPEAT** button to light the A.REPEAT indicator. When the end of the tape is reached, the unit automatically rewinds the tape to the beginning and repeats playback continuously.
- 2 To cancel the auto repeat playback mode, press the **A.REPEAT** button to turn off the A.REPEAT indicator.

RECORDING

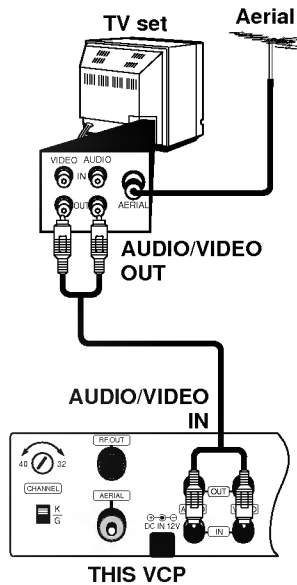

RECORDING (LINE)

This recording method can be only used to a TV with AUDIO/VIDEO output jacks.

- 1 Connect the VCP to a TV as shown left.
- 2 Turn the TV on and select the programme you wish to record with the TV's channel selector.
- 3 Insert a cassette with tab in place, or cover the hole with a piece of cellophane tape.

Perform the recording procedures below.

To begin a recording

Press the **REC** button to start recording. The REC indicator will be lit, and the VCP will be gone into the recording mode.

To stop a recording temporarily (PAUSE mode)

Press the **P/STILL** button. The VCP will be gone into the recording stand-by mode. Press the **P/STILL** button again. The VCP will be returned to the recording mode.

To stop a recording

Press the **STOP** (or **STOP/EJECT**) button to stop recording.

- ◆ Be sure to check that the safety tab on the video cassette is in place. If it is removed, recording will not start and video cassette will be ejected. Instead, the full auto play function will start.
- ◆ The tape will be rewound automatically when the end of tape is reached.
- ◆ To prevent damage to the tape, the VCP will automatically go into the stop mode after 5 minutes in the pause mode.

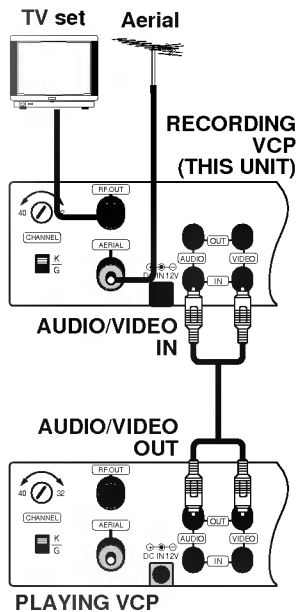

DUBBING TAPES

It is possible to copy recorded material on one tape onto that of another. In order to do this, you need access to a second VCP which must be connected to this VCP as follows.

- 1 Connect VIDEO OUT/AUDIO OUT of PLAYING VCP to VIDEO IN/AUDIO IN of RECORDING VCP.
- 2 Insert a recorded cassette into the PLAYING VCP and a blank video cassette into the RECORDING VCP (this unit).
- 3 Simultaneously begin playback on the PLAYING VCP and record on the RECORDING VCP.

CAUTION: Unauthorized recording of copyrighted television programmes, video tapes, or other materials may infringe on the rights of copyright owners and violate copyright laws.

ON SCREEN DISPLAY

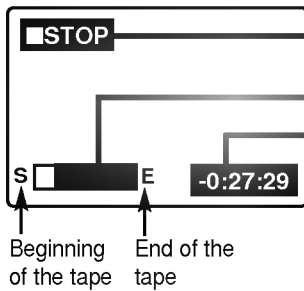

Some of these functions will be displayed every time the VCP is operated.

FUNCTION DISPLAY

Indicates the function in progress.

TAPE REMAINING DISPLAY

COUNT DISPLAY

Shows the tape counter on the tape.

Each press of the **DISPLAY** button changes the TV screen in the following sequence.

One press- (Full Function Display)

Two Presses- (Only Tape Counter)

Three presses- (No Display)

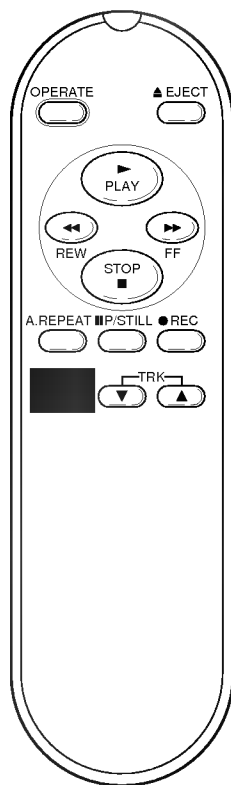
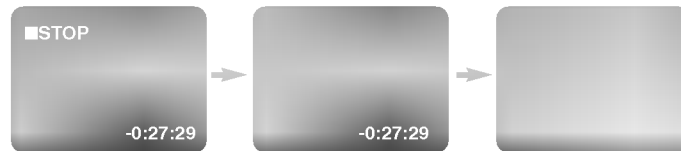

- After 3 seconds, Full Function Display will automatically disappear.
- The tape counter mode will continue until you press the **DISPLAY** button again.

BEFORE REQUESTING SERVICE

Check the following points before calling a service representative.

SYMPTOM	CHECK POINT & CORRECTION
No power...	<ul style="list-style-type: none"> • Check that the Power Plug is completely connected to its power source. • Check that the OPERATE button is set to ON.
Video cassettes can't be inserted...	<ul style="list-style-type: none"> • Check that the power cord completely connected to its source. • Insert the cassette with the window side up and the safety tab facing you.
RECORD mode can't be engaged...	<ul style="list-style-type: none"> • Place cellophane tape over missing safety tab.
There is no playback picture, or the playback picture has noise bars...	<ul style="list-style-type: none"> • Select the same channel on your TV as that of the RF channel control (Channel 32-40) on the VCP. • Check that the video channel 32-40 of your TV is properly adjusted. • Press the TRACKING (▼ or ▲) buttons to minimize the noise bars (Noise streaks only.) • Try a different cassette tape.
If the top of your playback picture waves back and forth excessively...	<ul style="list-style-type: none"> • Locate the horizontal hold control on your TV. Turn it slowly to correct the wavy picture.
Video cassette tape inserted incorrectly...	<ul style="list-style-type: none"> • Wait a few seconds. Tape should eject itself. • If the OPERATE indicator flashes on and off, press the OPERATE button again.

If the VCP does not operate normally despite repeating the checks above, please contact your nearest Service Center. Please have this **OWNER'S MANUAL** with you.

SPECIFICATIONS

Television System	: CCIR standard (625 lines 50 fields), PAL/SECAM colour system
Recording Format	: PAL/MESECAM
Tape Format	: Tape Width 1/2" (12.7mm high density tape VHS)
RF Output	: PAL/SECAM (G, K)
RF Modulator	: UHF channels 32-40 (Adjustable)
Dimensions (W X H X D)	: 290 X 92 X 345 mm
Weight	: Approx. 3.8 kg
Operating Temperature	: 5°C - 35°C
Operating Humidity	: 35 % - 80 %
Power Source	: AC 100-240V, 50/60Hz (DC 12 [±] 3V)
Power Consumption	: Approx. 13W
Audio Track	: Mono track type
Audio Input Level (RCA type)	: -4 dBm more than 47 kΩ
Audio Output Level (RCA type)	: -4 dBm less than 1 kΩ
Video Input Level (RCA type)	: 1.0 Vp-p, 75 Ω, unbalanced
Video Output Level (RCA type)	: 1.0 Vp-p, 75 Ω, unbalanced

- Design and specifications are subject to change without notice.



P/NO : 3834RP0022X