

V-4200HT, V-4200HTV
V-4200HTO, V-4200HTY
V-4200HTR, V-4200HTB
V-4200HTG

E | English
F | Français
N | Nederlands
D | Deutsch

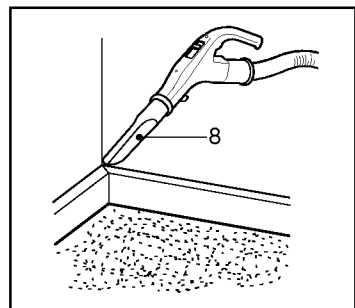

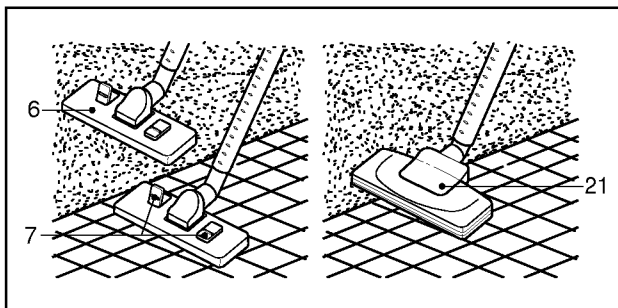
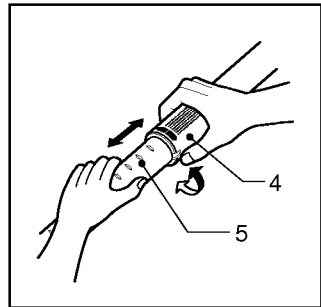
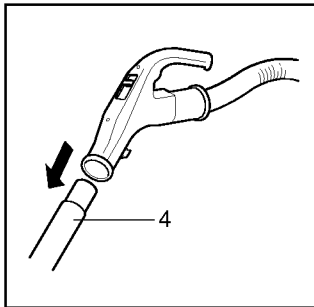
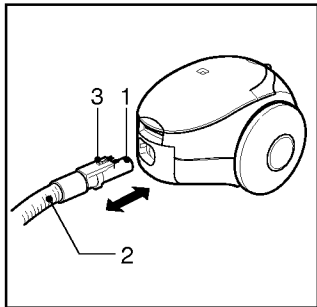
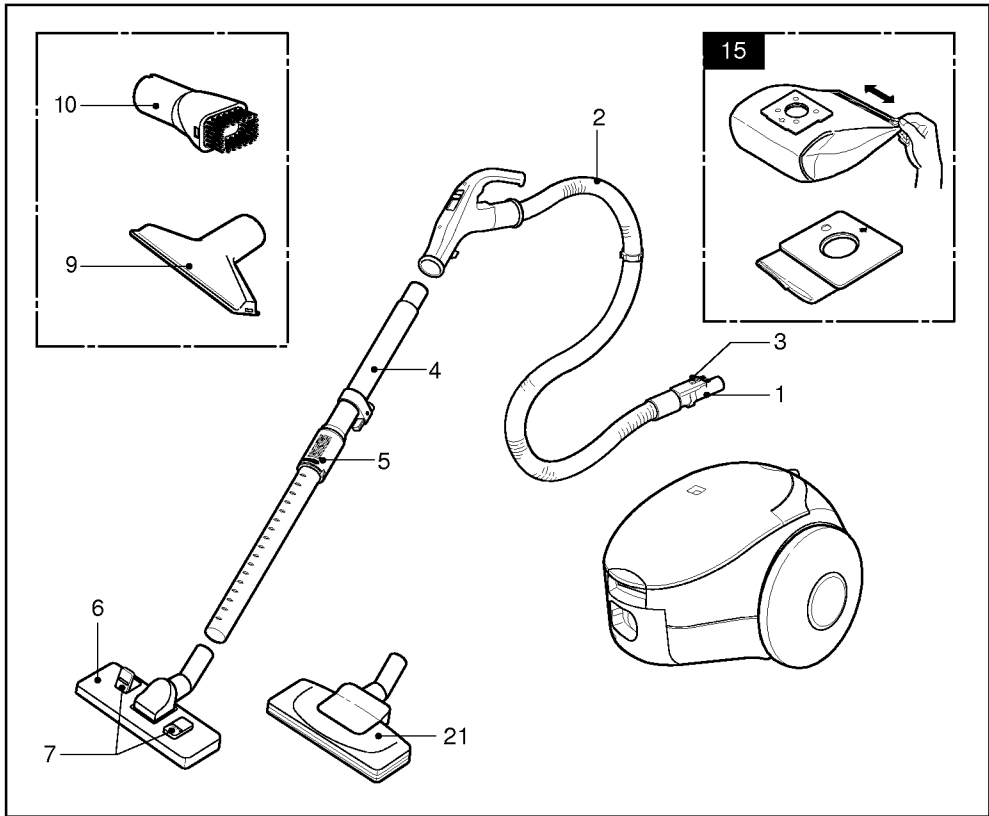
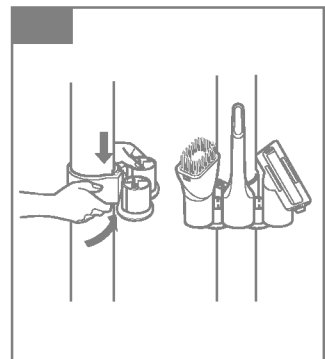
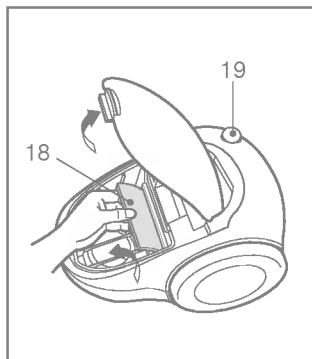
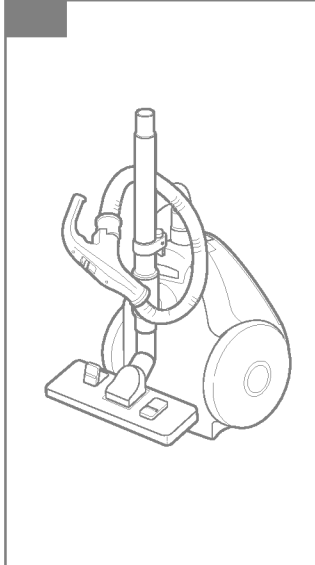
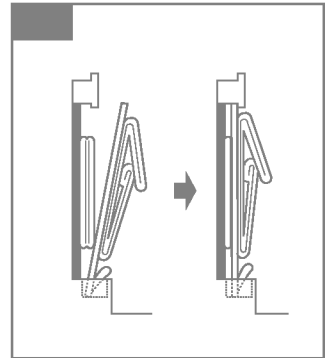
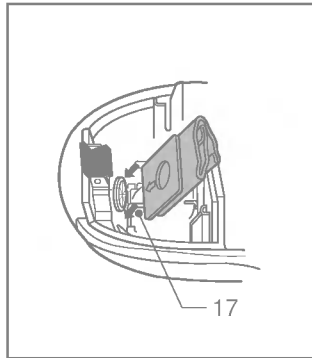
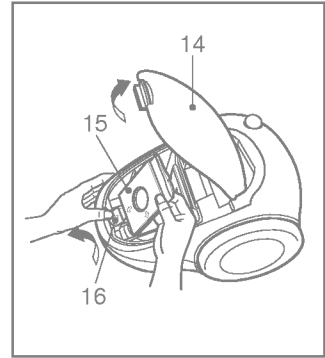
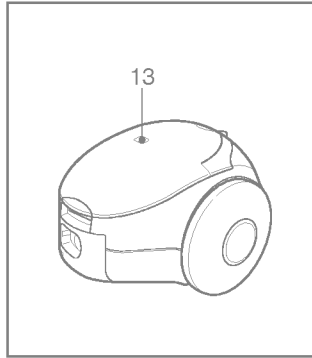
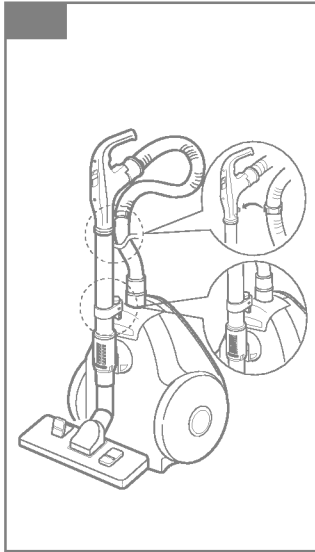
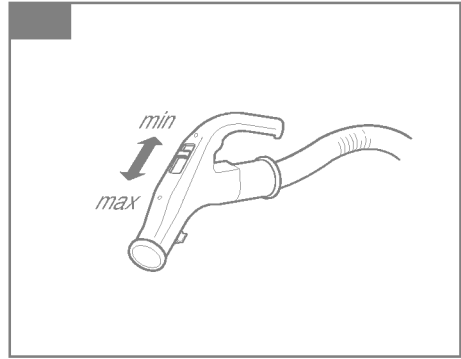
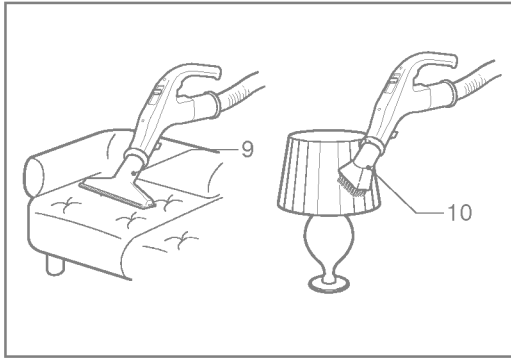

E

Information for your safety

Please read all the following information, which contains important instructions for the safety, the use and the maintenance of the appliance.

This appliance complies with the following EC Directives: -73/23/EEC, 93/68/EEC-Low Voltage Directive-89/336EEC -EMC Directive.

- Never allow children to use the appliance unsupervised.
- Do not use the appliance if the mains lead is damaged or faulty.
- If the supply cord is damaged, it must be replaced by an approved LG Electronics Service Agent to avoid a hazard.
- Always switch the vacuum cleaner off before :
 - changing the dust bag
 - changing or cleaning the filters.
- **If no dustbag is inserted, the cover cannot be closed. Please do not use force!**
- Do not vacuum flammable or explosive substances(liquids or gases).
- Do not vacuum hot ash, embers etc. nor sharp objects.
- Do not vacuum water or other liquids.
- Please make sure when using the carrying strap that it is securely fitted.
- When you vacuum with an attachment appliance that has a rotating brush roller:
 - do not reach into the running brush roller.

Important for users in the UK.

The wires in the mains lead of this appliance are coloured in accordance with the following code:

BLUE-neutral **BROWN - live**

As the colours of the wires in the mains lead of this appliance may not correspond with the coloured markings identifying the terminals in your plug,

PROCEED AS FOLLOWS:

The wire which is coloured **BROWN** must be connected to the terminal which is marked **L** or coloured **RED**.

The wire which is coloured **BLUE** must be connected to the terminal which is marked **N** or coloured **BLACK!**

VERY IMPORTANT:

Neither wire is to be connected to the earth terminal of a 3 pin plug. If a 13 amp plug is fitted, fit a 13 amp **BS 1362 fuse**.

If any other type of plug is used, protect with a 15 amp fuse at the distribution board.

For appliances which come with mains lead and plug moulded on : the plug moulded on to the cord incorporates a fuse.

For replacement use a 13 amp BS 1362 fuse. Only ASTA approved or certified fuses should be used.

The fuse cover/carrier must be replaced in the event of changing the fuse.

The plug must not be used if the fuse cover/carrier is lost. A replacement cover/carrier must be obtained from authorised electrical goods retailers.

WARNING! Should it become necessary to replace the moulded on plug then the detective plug should be destroyed to avoid any possible shock hazard that could occur should such a plug be inserted into a 13 amp socket elsewhere in the house.

How to Use

Connecting the flexible hose

Insert the hose holder(1) into the suction opening.

When the hose(2) is to be disconnected from the appliance, press the release button(3) and pull the hose holder out of the suction opening.

Assembling the tubes

•Telescopic tube(4)

- Release locking knob(5) (turn clockwise).
- Pull out tube to required length.
- Turn locking knob anti-clockwise as far as it will go.

Using the cleaning head and Accessory Nozzles

Fit the large cleaning head onto the end of the tube.

- **The 2 position head(6)** is equipped with a pedal(7) which allows you to alter its position according to the type of floor to be cleaned.

Hard floor position(tiles, parquet floors...). slide on the lever to lower the brush.

Carpet or rug position. slide on the lever to lift brush up.

- **If your appliance is equipped with an automatic cleaning head(21) without pedal, it automatically adapts to the type of floor to be cleaned.**
- **Crevice Tool(8)**
For vacuuming in those normally inaccessible places i.e. reaching cobwebs, or down the side of a sofa!
- **Upholstery Nozzle(9)**
For vacuuming upholstery, mattresses, etc. The thread collectors help to pick up the threads and fluff.
- **Dusting brush(10)**
For vacuuming picture frames furniture outlines, books and other uneven objects.
- Accessory Holder can be attached on the Extension wands using clamping hook.(20)
- Accessories can be stored in the holder.(20)

How to plug in and use

Pull out the mains lead to the desired length and plug into the socket.

Adjusting the power level

- **Electronic power control(11)**
Suction capacity increases steplessly up to MAX.

String the cleaner

When you have switched off and unplugged the appliance, press on the button(19) to automatically rewind the cord.(depending on model)

- Use storage clip as shown when storing the cleaner(12)

Changing the dust bag

The dustbag needs changing when the cleaner is set to maximum power and the cleaner head is off the floor but the "bag full" indicator window(13) is completely coloured red.

Even if the dustbag does not appear to be full at this stage, it should be changed.

It could be that a great deal of very fine dust has clogged up the pores of the dust bag.

- Turn off the appliance and unplug it.
- Remove hose.
- Open the cover (14)

Your appliance is equipped with either a paper dust bag or a fabric dust bag (15)

- Push the lever forwards in the direction of the arrow(16), and pull off the full paper filter bag towards the rear. Remove the bag and throw it away.

- Insert the new paper filter bag into the unit with the arrow pointing downwards(17) **if your appliance is fitted with a cloth filter bag**, empty it and replace it.

Note: as the appliance is fitted with a safety device which checks that the bag is in place you cannot close the lid if the bag is not fitted correctly.

Cleaning the motor filter

The motor filter is situated inside the appliance between the dust bag and the motor. Each time that you change the air outlet filter we advise you to remove the motor filter(18) and to clean it by tapping to remove the dirt and then replacing it in the vacuum cleaner.

What to do if your appliance does not work

Check that the appliance is correctly plugged in and that the electrical socket is working.

What to do when the suction performance reduces?

- Stop the appliance and unplug it.
- Check that the tubes, flexible hose and cleaning tool are not blocked.
- Check that the dust bag is not full. Replace it if necessary.
- Check that the air outlet filter is not blocked. Replace it if necessary.



Warranty Certificate

For offer a 12-month warranty for this apparatus

During the 12-month warranty period, we will repair your apparatus at no cost to you or make available spare parts to your dealer free, if this apparatus fails due to manufacturing or material defects. Further claims are excluded. We are not liable for damages due to acts of providence or damages occurring during transport. The buyer assumes shipping and packaging costs. **Your warranty conditions on the rear also apply!**

Type of apparatus: _____

Serial number:

Name of buyer: _____

Purchase date: _____

Dealer's stamp and signature

Warranty conditions for vacuum cleaner

1. **The warranty period begins** on the purchase date and is valid for 12 months. Begin of warranty period is proven if, the buyer submits purchase receipt together with the warranty card, filled in and signed by the seller. The serial number of the product must agree with the number entered onto the warranty card.
2. **During the warranty period, we will** correct any defects at no cost to you, if it can be proven that these are attributed to manufacturing or material defects.
3. Damages due to incorrect handling, non-compliance with instructions for use and normal wear **are not covered by this warranty**. Also, the warranty does not cover wear parts or easily broken parts (for example, viewing glass, light bulbs). The buyer is responsible for any damages during transport as well as shipping and packaging costs.
4. **We decide whether to make repairs, exchange or replace parts.** Exchanged or replaced parts are our property. The original warranty period is not prolonged if a refrigerator is repaired or certain parts are replaced.
5. **The warranty is nullified** if any person intervenes in the apparatus that are not authorised by LG Electronics, if the apparatus is used for commercial purposes.
6. **Always keep the original packaging,** so that if the apparatus requires servicing, it can be transported without damaging it.
7. **If a repair is covered by this warranty,** always contact your dealer or an authorised service centre.
8. **Further claims are excluded.** If parts of these provisions are invalid, they apply in the sense of the wording. The validity of the other provisions is not effected.