

V-C3440NB/ND/NT/NBV/NDV/NTV  
V-C3440SB/SD/ST/SBV/SDV/STV  
V-C3460NB/ND/NT/NBV/NDV/NTV

E | English  
F | Français  
N | Nederlands  
D | Deutsch

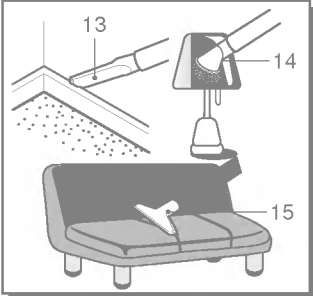

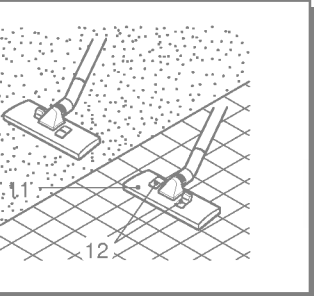
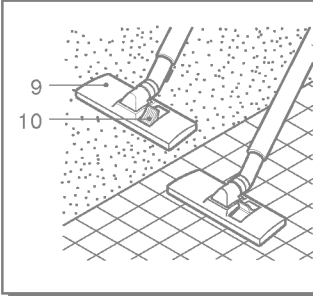
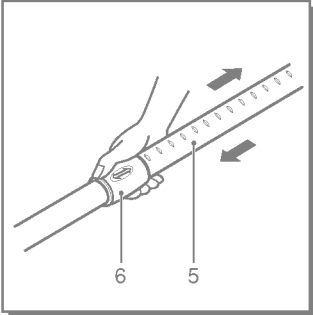
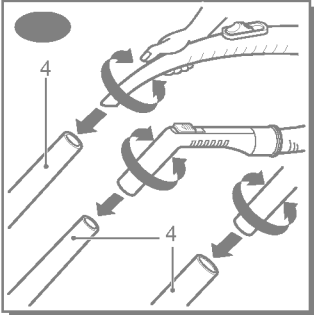
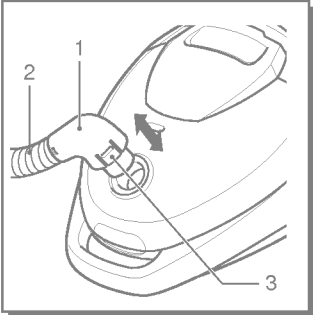
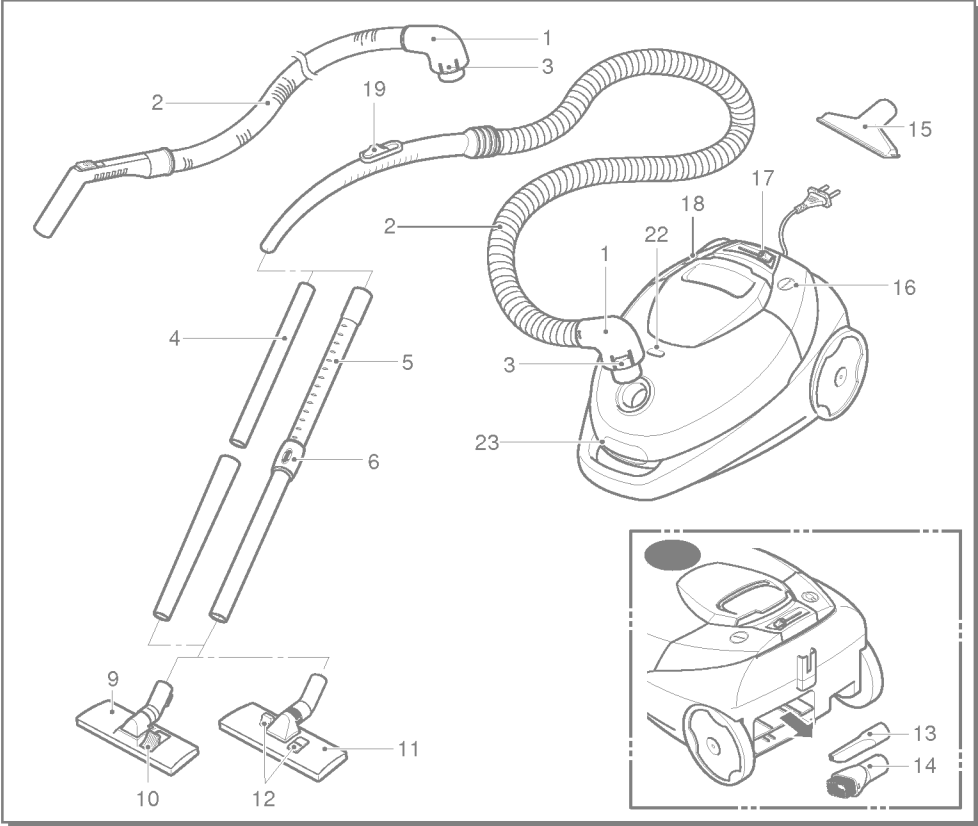
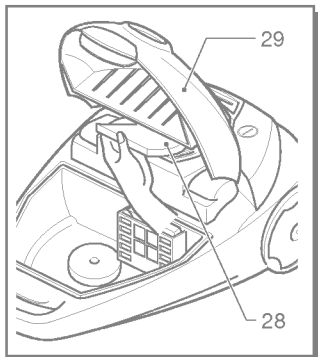
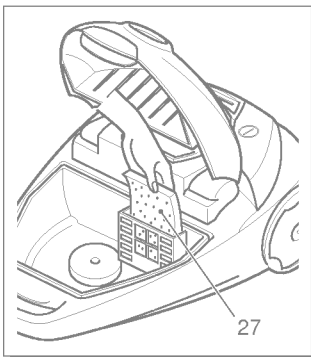
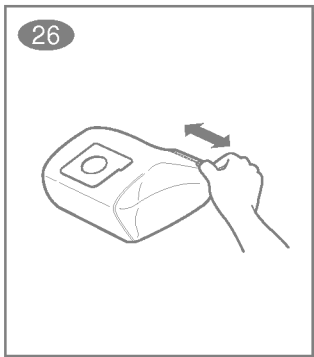
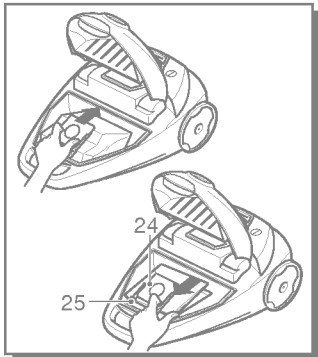
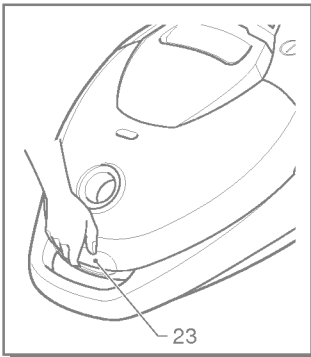
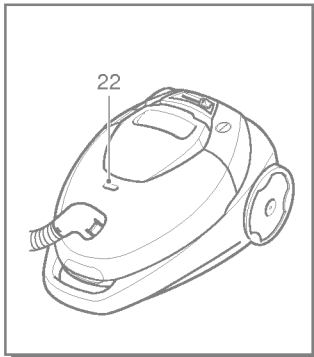
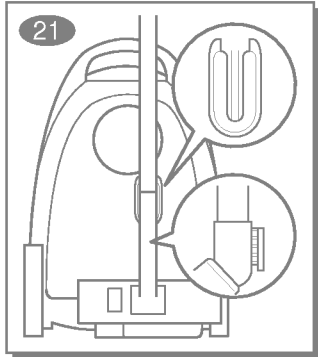
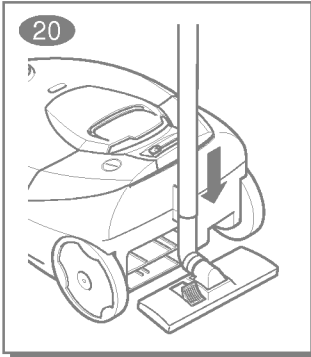
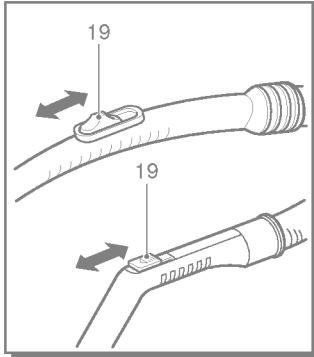
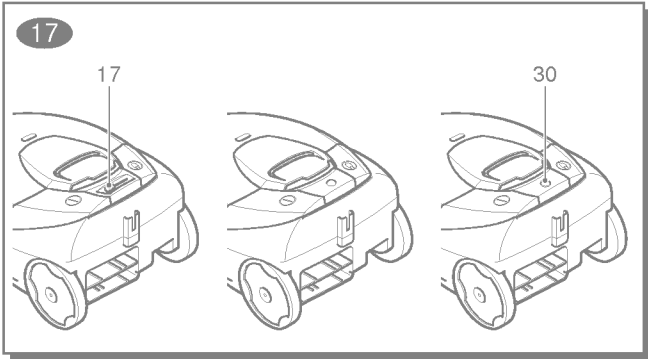
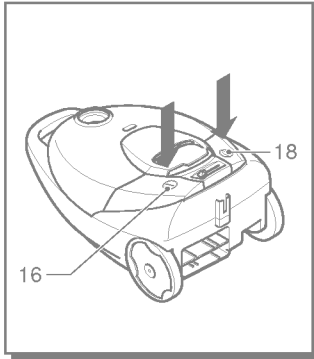

## Information for your safety

Please read all the following information, which contains important instructions for the safety, the use and the maintenance of the appliance. This appliance complies with the following EC Directives: -73/23/EEC, 93/68/EEC-Low Voltage Directive-89/336EEC-EMC Directive.

- Never allow children to use the appliance unsupervised.
- Do not use the appliance if the mains lead is damaged or faulty.
- If the mains lead is damaged, it must be replaced by an approved LG Electronics Service Agent as special tools are needed to repair it.
- Always switch the vacuum cleaner off before:
  - changing the dust bag
  - changing or cleaning the filters.
- **If no dust bag is inserted, the cover cannot be closed. Please do not close it by force!**
- Do not vacuum flammable or explosive substances(liquids or gases).
- Do not vacuum hot ash, embers or sharp objects.
- Do not vacuum water or other liquids.

## How to Use

### Connecting the flexible hose

Push the end of the head(1) on the flexible hose(2) into the attachment point on the vacuum cleaner. To remove the flexible hose from the vacuum cleaner, press on the button(3) situated on the head, then pull upwards.

### Assembling the tubes

(depending on model)

- Metal or plastic tube(4)
- Fit together the two tubes by twisting slightly.
- Telescopic tube(5)

- Hold spring latch(6).
- Pull out tube to required length.
- Release spring latch to lock.

### Using the cleaning head and

#### Accessory Nozzles(depending on model)

Fit the large cleaning head onto the end of the tube.

- **The 2 position head is equipped with a pedal(10) or two pedals(12) which allows you to alter its position according to the type of floor to be cleaned. **Hard floor position** (tiles, parquet floors...). Press on the pedal to lower the brush. **Carpet or rug position.** Press on the pedal to lift the brush up. **Carpet or rug position.** Press on the pedal to lift the brush up.**

- **Crevice Tool(13)**

For vacuuming in those normally inaccessible places like a window frame or a crevice in the wall.

- **Dusting brush(14)**

For vacuuming picture frames, furniture outlines, books and other uneven objects.

- **Upholstery Nozzle (15)**

For vacuuming upholstery, mattresses, etc.

### How to plug in and use

Pull out the mains lead to the desired length and plug into the socket. Press button(16) to start the vacuum cleaner.

To stop it press the button(16) again.

Adjusting the power level

### Adjusting the power level

- If your appliance is equipped with an electronic variable power control(17), you can choose the power appropriated for the task. The more you slide the button towards the right, the greater the suction power.
- The flexible hose handle has a manual air flow regulator(19) which allows you to briefly reduce the suction level(depending on model).
- **Booster:**If you push the booster button(30), you can use higher power than normal power for 10 seconds. The mode returns to the previous one automatically.

## Park-System(20)

For short breaks during vacuuming, for example to move a small piece of furniture or a rug, use the [Park system] to support the flexible hose and cleaning head.

- Slide the hook attached to the large cleaning tool into the slot on the rear of the appliance.

## Carrying and storage(21)

When you have switched off and unplugged the appliance, press the button(18) to automatically rewind the cord.

You can move or store your appliance in a vertical position by sliding the hook on the large cleaning head into the clip on the underside of the appliance.

## Changing the dust bag

The dust bag needs changing when the cleaner is set to maximum power and the cleaner head is off the floor but the "bag full" indicator window(22) is completely coloured red.

Even if the dust bag does not appear to be full at this stage, it should be changed.

It could be that a great deal of fine dust has clogged up the pores of the dust bag.

- Turn off the appliance and unplug it.
- Open the cover by pulling the latch(23) and lifting it up.

Your appliance is equipped with either a paper dust bag or a fabric dust bag(26) (depending on model)

- Take hold of the dust bag by the handle and pull. Remove the bag and throw it away.
- To refit a new bag, push the cardboard support of a new bag(24) into the bag mount(25) until it will go no further.

**If your appliance is fitted with a fabric dust bag** follow the same instructions as above. Empty it and replace it(26). Do not wash it.

## Cleaning the motor filter

The motor filter is situated inside the appliance between the dust bag and the motor. Each time that you change the air outlet filter

we advise you to remove the motor filter(27) and to clean it by tapping to remove the dirt and then replacing it in the vacuum cleaner.

## Changing the air outlet filters

Depending on the model you have chosen, your appliance is equipped with different types of filters : foam filter or electrostatic filter or anti-odor charcoal filter(28).

- To change these filters, open the filter cover(29) by pulling the latch(23) and then, change these filters.

- The foam filter, should be cleaned regularly by tapping it to remove the dirt.
- **The electrostatic filter or anti-odor charcoal filter** should be changed regularly (approximately every 6 bag changes).

### What to do if your appliance does not work

Check that the appliance is correctly plugged in and that the electrical socket is working.

### What to do when the suction performance reduces?

- Stop the appliance and unplug it.
- Check that the tubes, flexible hose and cleaning tool are blocked or not.
- Check that the dust bag is full or not. Replace if necessary.
- Check that the air outlet filter is blocked or not. Replace if necessary.

**Warranty Certificate**  
**For offer a 12-month warranty for this apparatus**

During the 12-month warranty period, we will repair your apparatus at no cost to you or make available spare parts to your dealer free, if this apparatus fails due to manufacturing or material defects. Further claims are excluded. We are not liable for damages due to acts of providence or damages occurring during transport. The buyer assumes shipping and packaging costs. **Your warranty conditions on the rear also apply!**

Type of apparatus: \_\_\_\_\_

Serial number:

Name of buyer: \_\_\_\_\_

Purchase date: \_\_\_\_\_

Dealer's stamp and signature

**Warranty conditions for vacuum cleaner**

1. **The warranty period begins** on the purchase date and is valid for 12 months. Begin of warranty period is proven if, the buyer submits purchase receipt together with the warranty card, filled in and signed by the seller. The serial number of the product must agree with the number entered onto the warranty card.
2. **During the warranty period, we will** correct any defects at no cost to you, if it can be proven that these are attributed to manufacturing or material defects.
3. Damages due to incorrect handling, non-compliance with instructions for use and normal wear **are not covered by this warranty**. Also, the warranty does not cover wear parts or easily broken parts (for example, viewing glass, light bulbs). The buyer is responsible for any damages during transport as well as shipping and packaging costs.
4. **We decide whether to make repairs, exchange or replace parts.** Exchanged or replaced parts are our property. The original warranty period is not prolonged if a refrigerator is repaired or certain parts are replaced.
5. **The warranty is nullified** if any person intervenes in the apparatus that are not authorised by LG Electronics, if the apparatus is used for commercial purposes.
6. **Always keep the original packaging,** so that if the apparatus requires servicing, it can be transported without damaging it.
7. **If a repair is covered by this warranty,** always contact your dealer or an authorised service centre.
8. **Further claims are excluded.** If parts of these provisions are invalid, they apply in the sense of the wording. The validity of the other provisions is not effected.