

CAUTION : The laser used in the CD-R/RW drive can damage your eyes.
Do not attempt to open the cover.
To reduce the risk of electric shock, do not remove cover (or back).
No user-serviceable parts inside.
Refer servicing to qualified service personnel.

Use of controls or performance of procedures other than those specified here in may result in hazardous radiation exposure.

WARNING : To reduce the risk of fire or electric shock, do not expose this appliance to rain or moisture

This unit uses CD-RW discs with the following mark.	
This unit uses CD-R discs with the following mark.	
This unit uses CD-ROM discs with the following mark	
When you use this unit as a CD player, use compact discs with the following mark.	

- PC DOS is a trademark of IBM Inc.
- Adaptec and the Adaptec logo are trademarks of the Adaptec Corporation.
- MS-DOS, Windows, and Windows® 95 are trademarks registered in the United States and other countries by the Microsoft Corporation.
- The company names and product names written in this manual are trademarks or registered trademarks of the respective companies.

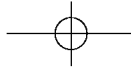

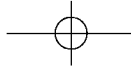

English

Industry Canada requirement

This class B digital apparatus meets all requirements of the Canadian Interference-Causing Equipment Regulations.

Cet appareil numérique de la classe B respecte toutes les exigences du Règlement sur le matériel brouilleur du Canada.

FCC COMPLIANCE STATEMENT

Note : This equipment has been tested and found to comply with the limits for a Class B digital device, pursuant to Part 15 of the FCC Rules.

These limits are designed to provide reasonable protection against harmful interference in a residential installation. This equipment generates, uses, and can radiate radio frequency energy and, if not installed and used in accordance with the instructions, may cause harmful interference to radio communications. However, there is no guarantee that interference will not occur in a particular installation. If this equipment does cause harmful interference to radio or television reception, which can be determined by turning the equipment off and on, the user is encouraged to try to correct the interference by one or more of the following measures:

- Reorient or relocate the receiving antenna.
- Increase the separation between the equipment and receiver.
- Connect the equipment into an outlet on a circuit different from that to which the receiver is connected.
- Consult the dealer or an Authorized Service Center for help.

• **FCC WARNING**

Changes or modifications not expressly approved by the party responsible for compliance could void the user's authority to operate the equipment.

- This CD-R/RW Drive is for use only with UL listed personal computers that have installation instructions detailing user installation of card cage accessory.

This product is manufactured to comply with the radio interference requirements of EEC DIRECTIVE 89/336/EEC, 93/68/EEC and 73/23/EEC.

CAUTION - INVISIBLE LASER RADIATION WHEN OPEN AVOID EXPOSURE TO BEAM.

VARNING-OSYNLIG LASERSTRÄLNING NÄR DENNA DEL ÄR ÖPPNAD STRÅLEN ÄR FARLIG.

CLASS 1	LASER PRODUCT
KLASSE 1	LASER PRODUKT
LUOKAN 1	LASER LAITE
KLASS 1	LASER APPARAT

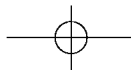

DECLARATION OF CONFORMITY

This device complies with Part 15 of the FCC Rules. Operation is subject to the following two conditions : (1) this device may not cause harmful interference, and (2) this device must accept any interference received, including interference that may cause undesired operation.

Trade Name/Model : LG or GoldStar/CED-8080B, CED-8081B, CED-8083B

Responsible Party : LG Electronics U.S.A. Inc.
Address: 6133 N. River Road, Suite 1100
(Riverway Plaza) Rosemont, IL 60018
Contact Person : Mr.P. H. Byun, General Manager
Tel. No. (847) 993-4529

Equipment Classification : FCC Class B Peripheral Device(JBP)

Type of Product (EUT) : CD-R/RW Drive

Manufacturer: LG Electronics Inc.

Address: 19-1, Cheongho-Ri, Jinwuy-Myon
Pyungtaek-Shi, kyunggi-Do, 451-713 Korea

Attention : Mr.T.K.Lee - General Manager

Multimedia Standards Team

We hereby declare that the equipment bearing the trade and model number specified above was tested conforming to the applicable FCC Rules under the most accurate measurement standards possible, and that all the necessary steps have been taken and are in force to assure that production units of the same equipment will continue to comply with the Commission's requirements.



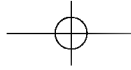

Contents

Introduction	Features	2
	Important Precautions	3
	System Environment	4
	Location and Function of Controls	5
Installation	Installing the Drive	7
	Device Drivers	13
Operation	How to Use the Discs	15
Appendix	Troubleshooting	16
	Specifications	17
	Warranty	18



CED-8083B: 4X^{Record}/4X^{ReWrite}/32X^{Read}

CED-8080B/CED-8081B: 8X^{Record}/4X^{ReWrite}/32X^{Read}

* Writing speed depends on capabilities of discs. As a result, you should use media labelled 4X ReWritable discs.

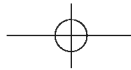

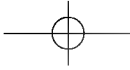

Introduction

**Thank you for
purchasing this
CD-R/RW Drive.**

Features

- Running OPC* gives a flatter writing signal that improves reliability.
- Easy-to-use tray model.
- Enhanced-IDE (ATAPI) model.
- Can read not only CD-R and CD-RW discs, but also video CDs, music CDs, and photo CDs.
- The recorded CD-RW media can be played in a DVD player or a multiread CD-ROM Player, maintaining future compatibility.
- Supports UDF for easy writing to CD-RW discs.

* Continuously monitors the signal level during recording and adjusts the laser power to compensate when the disc is dirty, insuring a flat signal.

Package Items

Item	Quantity
- Internal CD-R/RW Drive	1
- CD Recording Software	1
- Blank CD-RW Disc	1
- Blank CD-R Disc	1
- Device Driver (MS-DOS)	1
- E-IDE (ATAPI) cable	1
- Audio Cable	1
- Mounting Screws	4
- Manual for CD-R/RW Drive	1
- Manual for CD Recording Software	1

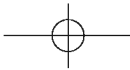

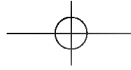

Important Precautions

Follow these precautions when handling the drive or discs.

Precautions

- Please take notice that the manufacturer of this equipment does not offer any warranty against data loss due to inappropriate installation or handling, or direct or indirect damages.
- Please take notice that the manufacturer will bear no responsibility for direct or indirect damages caused by the use of this product or its malfunction.
- Please take notice that the manufacturer will bear no responsibility for damage to data caused by this product.
- Please backup (copy) all important data as protection against data loss.

Installation

- Avoid placing the drive in a location subject to:
 - high humidity
 - high temperature
 - excessive dust
 - mechanical vibration
 - direct sunlight

We recommend using the drive in a horizontal position.

Do not use it in a tilted or vertical position.

Operation

- Don't move the drive suddenly from a cold place to a warm one or raise the room temperature suddenly. Condensation may occur, causing abnormal operation.
- Make sure to remove the disc before moving the drive. The disc may be damaged, causing data loss.
- Be careful to prevent foreign objects, such as liquids or metal, from entering the drive. In case a foreign object enters the drive, please consult the dealer where the drive was purchased.
- Don't interrupt the electric power while the drive is operating.
- When connecting two IDE devices to the Primary or Secondary connectors, make sure that the two devices are not configured as both Master, or both Slave. If they are both set the same, Windows may fail to run or recognize the drives.
- The total length of the IDE cable should be no more than 18 inches (about 45 cm).

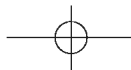



Computer

System Environment

This unit can be operated in the system environment explained here.

System requirements	CPU	200MHz (or faster) Pentium (for 8X speed, 233MHz or faster recommended)
	Memory	Windows 98/95 : 32MB or greater. Windows NT Workstation Ver. 4.0: 32MB or greater (64MB or over recommended) Windows 2000:64MB or greater(128MB or over recommended)
Hard disk	Hard disk with average access time of 19 msec or less, and data transfer speed of 1200KB/sec or greater. 75MB or more free space. (The free space needed for writing depends on the quantity of data.)	
Interface	Enhanced-IDE interface (as Primary Slave, Secondary Master or Slave)	
Drive bay	5.25-inch half-height bay required	
Power	+5V/+12V power socket required	
Software Required OS	Windows 2000/98/95, Windows NT Workstation Ver.4.0 or later*	
CD-R, CD-RW discs	<p>CD-R : Ricoh, Mitsubishi Chemical, Verbatim, Taiyo Yuden, Mitsui Toatsu, TDK, Kodak, or SKC discs are recommend.</p> <p>CD-RW : Ricoh, Mitsubishi chemical, Verbatim, Imation, Sony discs are recommend.</p>	

Occasionally the CD-R and CD-RW discs written by the CD-R/RW drive cannot be read by other CD drives*. These unreadable discs should be read using the CD-R/RW drive on which require written.

* With Windows NT Workstation Ver. 4.0, the drive is usable only with Adaptec EASY CD CREATOR.

* The disc written using the CD-R/RW drive might not be readable by CD-ROMs other than Multi-read compatible (UDF compatible) CD-ROMs.

Multiread compatible (UDF compatible) CD-ROMs are:

1. CD-ROMs that can read low reflectance.
2. CD-ROMs that support Packet Write.

Software

Install the supplied CD Recording Software before using this unit.

DirectCD™ v2.5b(s)

Location and Function of Controls

Front Panel

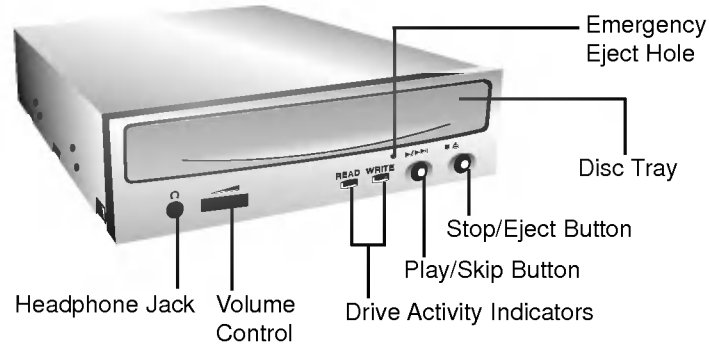

1. Disc tray

This is the tray for the disc. Place the disc on the ejected disc tray, then lightly push the tray (or push the eject button) and the CD will be loaded.
NOTE: Don't pull out or push in the disc tray forcibly. This might cause damage to the loading section of the drive.

2. Stop/Eject button

Press this button to open the CD tray.
This button works only when power is supplied to the drive.
If an Audio CD is playing, pressing this button will stop it, and pressing it again will open the tray.

3. Play/Skip button

When an Audio CD is in the disc drawer, pressing this button will start playing Audio CDs from the first track. If an Audio CD is playing, pressing this button will skip to the next track.

4. Volume control

Adjust the output volume of the headphone jack with this control. It can't be used to adjust the output volume for the audio output connectors on the rear panel.
NOTE : Turn the volume down before turning on the power. Sudden loud noises can damage your hearing.

5. Headphone jack

This jack is for connecting headphones or mini-speakers.

6. Drive activity indicators

Two colored LEDs are used to indicate the operation of CD-R/RW Drive.

(1) Read

The orange color is displayed when the spindle motor begins the Spin up operation: accessing data, reading data, playing Audio, and up loading tray.

(2) Write

The green color is flashed during disc writing sessions.

DirectCD™ v2.5b(s)

Rear Panel

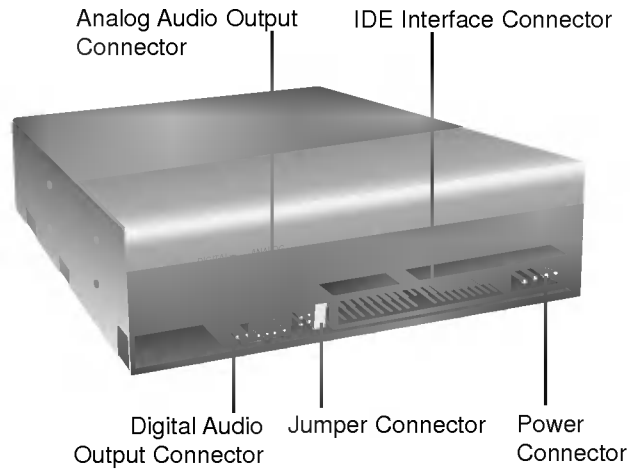

1. Power Connector

Connects to the power supply (5-and 12-V DC) of the host computer.

NOTE : Be careful to connect with the proper polarity. Connecting the wrong way may damage the system (and is not guaranteed). Usually this connector can only be attached one way.

2. IDE Interface Connector

Connect to the IDE (Integrated Device Electronics) Interface using a 40-pin flat IDE cable.

NOTE : Do not connect or disconnect the cable when the power is on, as this could cause a short circuit and damage the system. Always turn the power OFF when connecting or disconnecting the cable.

3. Jumper Connector

This jumper determines whether the drive is configured as a master or slave. Changing the master-slave configuration takes effect after power-on reset.

4. Analog Audio Output Connector

Provides output to a sound card (analog signal). Generally you need this to play a regular audio CD.

5. Digital Audio Output Connector

Provides output to a sound card (digital Signal).

Before Installation

Removing the Computer Cover

Installing the Drive

Before installing the drive, please note the following points.

- You will need the following:
 - A screw driver of a suitable size to fit the securing screws for the drive unit.
 - The manual for the computer, so you can find the mounting positions for the IDE controller.
- Turn off all peripheral appliances of the computer and the computer itself, and disconnect their power cords from the wall sockets.
- Discharge any static electricity on your person by touching the computer covers, etc.

Make sure all peripheral devices of the computer and the computer itself are turned off, and then remove the cover. Refer to the manual for the computer for details about removing the cover.

NOTE : There may be sharp edges inside the computer so take care to avoid injury.

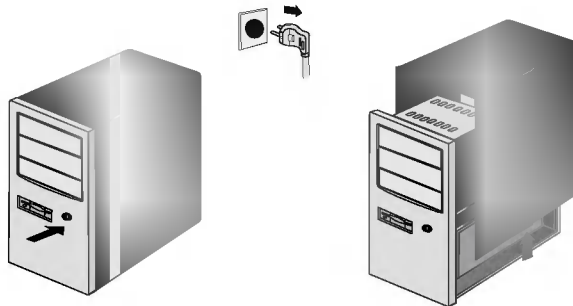

Computer OFF.

Mounting the Drive

1. Remove the 5¼" drive bay panel from the computer. Refer to the manual for the computer for details.

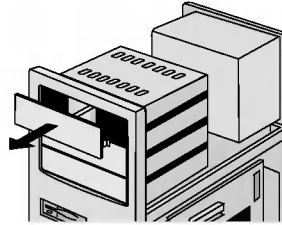

2. Insert the drive unit into the bay. Do not apply excessive pressure to the cables inside the computer.
3. Secure the drive with the screws provided. If there is not enough space behind the drive, connect the IDE and other cables before securing the drive.

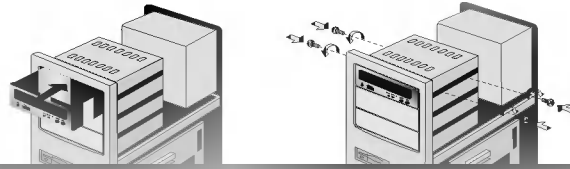

NOTE : This is a general installation guide. If your PC hardware appears different, please consult your hardware manual for installing peripheral devices.

Connecting the Power Connector

Connect the power cable from the computer's power supply to the socket on the drive unit, fitting the connector firmly into the power in connector.

If there is no spare power cable available in the computer, you will have to purchase a splitter cable of a suitable type.

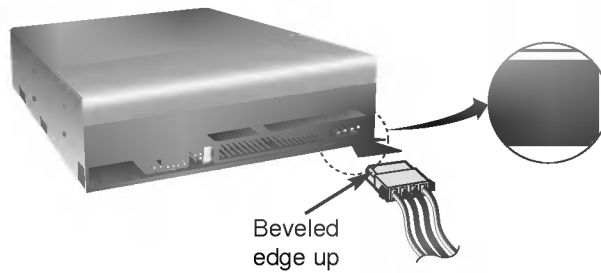

NOTE : Improper connection may damage the drive and void the warranty.

Connecting the Interface Connector

Connect the 40 pin IDE cable to the back of the CD-R/RW Drive, making sure the coloured (red) stripe on the IDE cable is connected to pin 1 on the CD-R/RW drive.

NOTE : Generally, the IDE connector is keyed and will only fit one way.

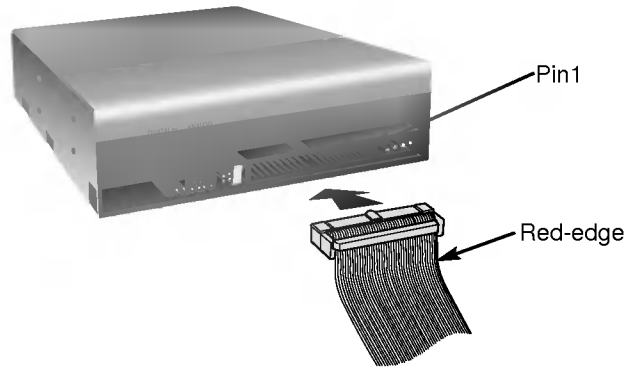

Connecting the Sound Card

If the computer is using a sound card, the drive is connected to the sound card with an audio cable. The supplied analog audio cable fits most sound cards or one can be purchased at a local computer store.

Refer to the manual for the sound card for detailed information regarding connection.

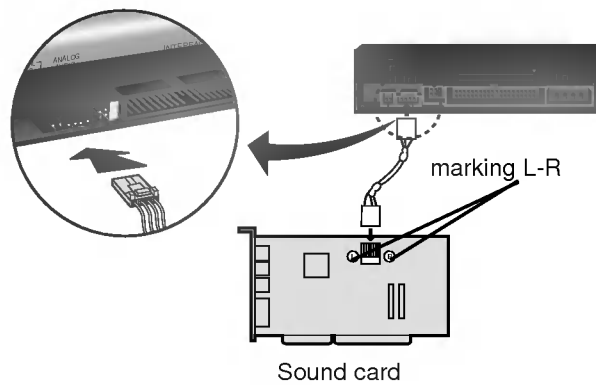

Jumper Setup

Before installation, set the jumper on the jumper connector on the rear panel.

The drive can be connected as the Master or Slave on an EIDE (ATAPI) interface. When several (up to four) EIDE devices are connected, each must be set in a unique way. Specific knowledge of hardware and software is necessary to install the drive.

NOTE : If two peripheral devices with the same settings are both connected to the Primary or to the Secondary EIDE bus, the host computer may fail to run or may malfunction. Careful attention is necessary.

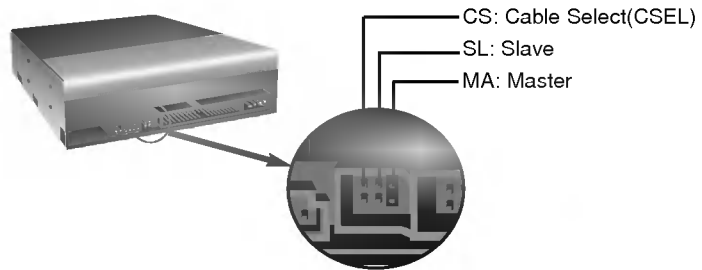

NOTE : Only one jumper should be installed on the jumper connector. If more than one jumper is installed, the drive may malfunction or be damaged.

Master/Slave setting is determined by jumper installation on the Jumper Connector. The following table shows the possible jumper settings.

Name	Function	C	S	M
		S	L	A
MA (Master)	Drive set as Master (factory default)	<input type="radio"/>	<input type="radio"/>	<input checked="" type="radio"/>
SL (Slave)	Drive set as Slave	<input type="radio"/>	<input checked="" type="radio"/>	<input type="radio"/>
CS (Cable Select)	Drive mode set by CSEL on the host IDE interface	<input checked="" type="radio"/>	<input type="radio"/>	<input type="radio"/>

If you use CSEL setting, the MASTER/SLAVE setting will be made automatically, depending on the hardware configuration. For details refer to the manual of your computer.

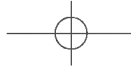

PC Connection

The CD-R/RW drive connects to the motherboard of the host computer using an IDE interface cable. You may connect the CD-R/RW Drive as a Slave or Master device, depending on your computer.

To Install as a Master Drive

To install the drive as a Master, the jumper can be left as supplied from the factory.

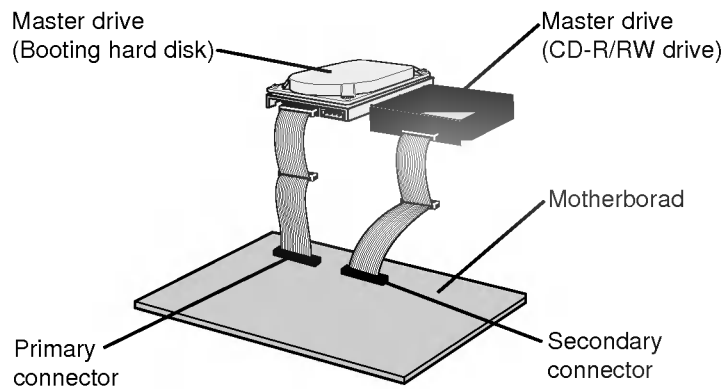

- OR -

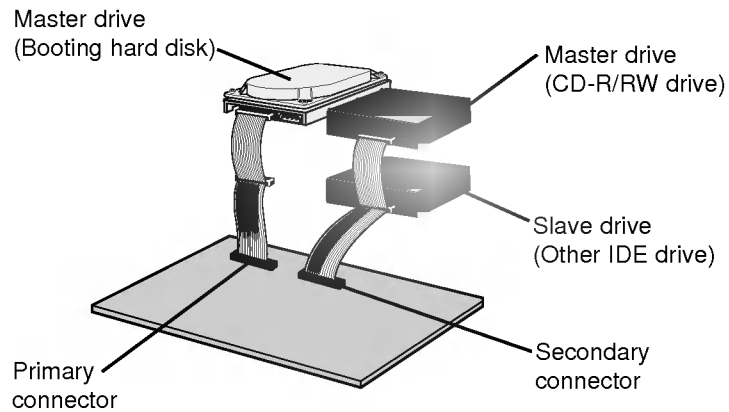

NOTE : A hard disk is normally installed as the Primary Master on the EIDE (ATAPI) interface. Other EIDE peripheral devices such as hard drives and CD-ROMs are then set differently.

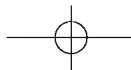

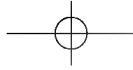

To Install as a Slave Drive

To install the drive as a Slave, change the jumper setting on the rear panel to SL.

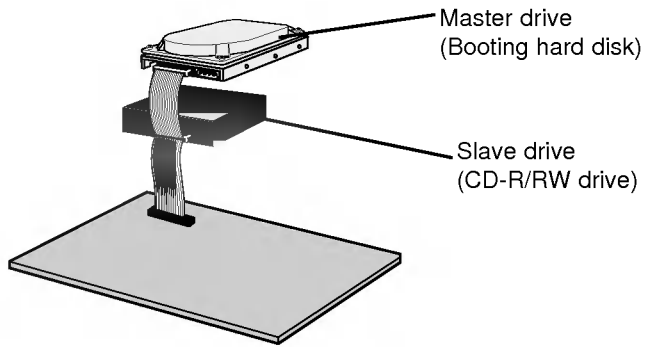

- OR -

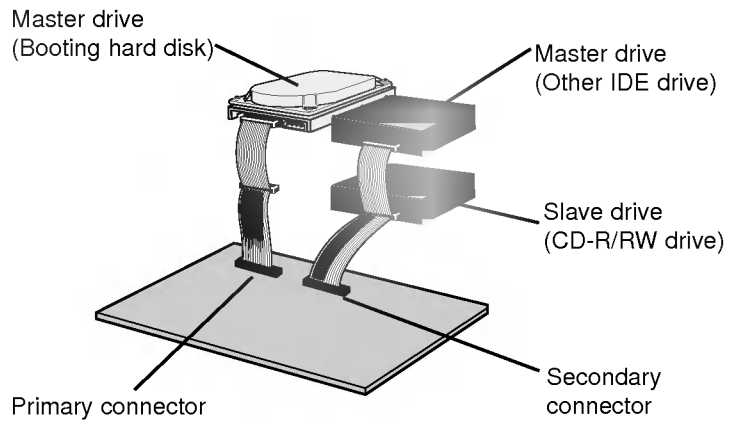

Replacing the Computer Cover

When the installation of the drive unit is complete, replace the computer cover.

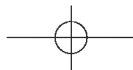

Device Drivers

When using Windows 2000/98/95 or Window NT Workstation Ver.4.0, no special device driver is required.

This CD-R/RW drive is supplied with MS-DOS drivers on a 3 1/2" floppy disk. These drivers are required to use the CD-R/RW drive in DOS or to enable the CD-ROM disk. Drivers for other Operating Systems are not normally required or available as they usually have a generic IDE, E-IDE/ATAPI CD-ROM driver built in (Windows 95, 98, 2000, NT 3.51 and higher and OS/2 Warp 3 are such examples).

If it is necessary to edit any file manually, first make a backup copy on a floppy, then the original file, then save the changed file to your hard drive, exit and re-boot PC to ensure the change will be implemented.

The Setup Process

For non-Windows 95/98/2000/NT and OS/2 Warp 3 Installation

The INSTALL program performs the following functions:

- Allows the user to select the target drive and directory in DOS.
- Unless modified by the user, the INSTALL program searches the target drive for the directory (\CDROM): if this is not found, the directory will be created.
- Copies the CD-R/RW device driver file named GSCDROM.SYS, the Microsoft CD-ROM Extension file named MSCDEX.EXE and the utility files to the specified directory.
- Modifies your CONFIG.SYS file to list the location and name of the device driver.
- Modifies your AUTOEXEC.BAT file to load MSCDEX

List of Files to be Installed In Your PC

MSCDEX.EXE	Microsoft MS-DOS CD-R/RW Extension software, which enables the computer to access the CD-R/RW drive.
GSCDROM.SYS	CD-R/RW device driver.
EJECT.EXE	Software eject program which can eject the CD tray.
CLOSE.EXE	Software close program which can close the CD tray.

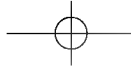

Running the Install Program (MS-DOS Installation)

1. Insert the diskette into the appropriate drive.
2. Go to the floppy drive by typing A: or B: at the DOS prompt, as appropriate.
3. Type the word INSTALL and press [ENTER].
4. The INSTALL program will begin loading. When loading is complete, the INSTALL program identification will appear on screen.
5. Follow the instructions on screen.
6. When installation is complete, remove the diskette and reboot your PC.

For Windows 98/95 Users

- In order to ensure normal drive operation, please check the following:
 - The drive is displayed in [Control Panels]-[System]-[Device Manager]-[CD-ROM]
 - 32-bit is displayed in [Control Panels]-[System]-[Performance]
- If the drive is not recognized by your computer, please check the following items.
 - If a  indicator is displayed on the IDE controller in [Control Panels]-[System]-[Devices Manager]-[Hard Disk Controller], you will need to contact your PC's manufacturer or the motherboard's manufacturer and get the appropriate IDE controller driver.
- Run **Add New Hardware** in Control Panel to let PC search again for new device.

For Windows NT Workstation Ver.4.0 Users

- In order to ensure normal drive operation, please check to see if the drive is displayed on the IDE controller in [Control Panels]-[SCSI Adapter]-[Devices]
- If the drive is not recognized by your computer, a  indicator is displayed on the IDE controller in [Control Panels]-[SCSI Adapter]-[Devices], you will need to contact your PC's manufacturer or the motherboard's manufacturer and get the appropriate IDE controller driver.

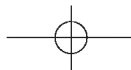

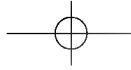

Emergency Eject

How to Use the Discs

When using CD-ROM discs, CD-R discs or CD-RW discs, don't attach any stickers or labels to the discs. Using discs with them attached not only causes read and write errors, but data on the disc may be lost due to damage to the disc itself.

This drive has a function that allows the CD to be ejected manually if this becomes necessary in an emergency, such as failure of the drive or a power outage.

NOTE: Don't use this feature except in an emergency.

- 1) Turn the power to OFF.
- 2) Poke a fine-tipped object (such as a straightened heavy duty paper clip) into the small hole above the eject button. The front door will pop open and the disk tray will come partway out.
- 3) Pull the front door to open it all the way, then grip the disc tray between thumb and forefinger and gently pull it straight out.



NOTE: This feature is a last measure to be used only in an emergency. Using it excessively will cause malfunction.

* If you cannot get a good grip on the disc tray with your fingers, use a steel binder clip or spring clamp to pull it out.

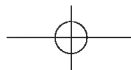

Appendix

Before Requesting Service

Before calling for service, check this list.

- The drive doesn't have power.
 - Is the power supply cable from the host computer plugged in?
 - Is the Power Connector to the drive securely attached?

- The system doesn't start.
 - Are the Primary and Secondary connections and the Master and Slave settings correct?
 - Is the total length of the IDE cable 18 inches or less?
 - Is each connector completely attached?
Movement of the PC may loosen connections.

- Cannot Read or Write Discs.
 - Is the condition of everything else in the system (CPU, hard disc, and others) as it should be? (See system environment page 4.)
 - Does the CD-R or CD-RW disc have dirt or scratches?
 - Did a screen saver or other application operate while writing to the disc?
 - Is there enough free space on the CD-R/RW disc?
 - Does writing fail even using the simulation test?
 - Is the disc loaded in the drive with the read/write surface facing the right direction? (label up)
 - Is the drive installed in the correct orientation?
 - Was the drive or disc moved from a low temperature environment to a high temperature environment? (There is a possibility of condensation on the lens in the drive or on the surface of the disc.)

When you call for service, be prepared to give as much information as possible of your system, environment, and the specific problem. (What happened? When? How long? What was going on? Were there any error messages displayed? etc.)

Specifications

Type	Internal type (bare drive)			
Interface	Enhanced-IDE (ATAPI)			
Data buffer memory	2MB			
Disc diameter	12cm, 8cm			
Data Transfer Rate	* Sustained Read : 14 to 32X CAV: 2.1MB to 4.8MB/sec Write : 2X: 300KB/sec. 4X: 600KB/sec. 8X: 1200KB/sec(Model : CED-8080B/CED-8081B only.) * Burst (ATAPI) 16.67MB/sec (PIO Mode 4, MULTI-DMA Mode 2)			
Average access time	Random 100m sec <Typical>			
Mounting direction	Horizontal/Vertical			
Compatible formats	Format	<Write>	<Read>	<Play>
	CD-DA	•	•	•
	CD-ROM	•	•	
	CD-Extra	•	•	•
	CD-ROM XA	•	•	•
	Photo CD	•	•	
	CD-I	•	•	
	CD-ROM+CD-DA	•	•	•
	Video CD	•	•	•
Loading system	Tray type (automatic loading/eject)			
Power	DC5V, DC12V			
Weight	Less than 1.1Kg			
Dimensions	146 x 201 x 41.5 mm (Width, depth, height)			
Error Rate	10 ⁻¹² bits or less			
MTBF	120,000 hours Power On Hours (Duty Cycle 10%)			
MTTR	Within 30 minutes			
Audio Output Level	Line out : 0.7 Vrms at 47 kohm Headphone : 0.6 Vrms at 32 ohm			
Environmental Conditions	When operating		When not operating	
Temperature	5 °C to 40 °C (No air cooling)		-20 °C to 60 °C	
Humidity	10% to 80% R.H. (No condensation)		10% to 80% R.H. (No condensation)	

The drive's appearance and specifications may change without notice.

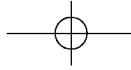

CD-R/RW LIMITED WARRANTY

LG Electronics Inc. will repair or at its option replace*, without charge, your product which proves to be defective in material or workmanship under normal use, during the warranty period listed below from the date of original purchase.

MODEL #	WARRANTY PERIOD	
	Div.	Labor & Parts
CED-8080B/ CED-8081B/ CED-8083B	Personal or Non-Income producing use:	1 Year
	Commercial or Income producing use:	90 days

No other express warranty is applicable to this product. THE DURATION OF ANY IMPLIED WARRANTIES, INCLUDING THE IMPLIED WARRANTY OF MERCHANTABILITY, IS LIMITED TO THE DURATION OF THE EXPRESS WARRANTY HEREIN. WE SHALL NOT BE LIABLE FOR THE LOSS OF THE USE OF THE PRODUCT, INCONVENIENCE, LOSS OR ANY OTHER DAMAGES, DIRECT OR CONSEQUENTIAL, ARISING OUT OF THE USE OF, OR INABILITY TO USE, THIS PRODUCT OR FOR ANY BREACH OF ANY EXPRESS OR IMPLIED WARRANTY, INCLUDING THE IMPLIED WARRANTY OF MERCHANTABILITY APPLICABLE TO THIS PRODUCT.

Some states do not allow the exclusion or limitation of incidental or consequential damages or limitations on how long an implied warranty lasts; so these limitations or exclusions may not apply to you. This warranty gives you specific legal rights and you may also have other rights which vary from state to state.

THE ABOVE WARRANTY DOES NOT APPLY:

1. To damages or problems which result from delivery or improper installation.
2. To damages or problems which result from misuse, abuse, accident, alteration, or incorrect electrical current or voltage, maintenance conditions.
3. To service calls which do not involve defective workmanship or material and explaining the operation of the unit.
4. If the serial number of the drive is defaced or missing.

Therefore these costs are paid by the consumer.

CUSTOMER ASSISTANCE NUMBERS:

If you have questions about using this product, check your user's manual first. You will find answer to most of your questions there. If you need further assistance, please contact us. We offer the following support and information services.

- To Prove Warranty Coverage:
 - ➔ Retain your Sales Receipt to prove date of purchase.
 - ➔ Copy of your Sales Receipt must be submitted at the time warranty service is provided.
- To Obtain Product, Customer, or Service Assistance:
 - ➔ Call 1-800-243-0000 24 hrs/7 days
 - ➔ Push appropriate menu code.
 - ➔ or <http://www.LGService.com/techsup.html> for support by E-mail.
- For Exchange Service:
 - ➔ Call 1-800-243-0000 (Mon~Fri 8am~5pm CST)
 - ➔ Push appropriate menu code.

* Replacement is a factory-reconditioned unit. Free replacement applies only within the initial one-year period. Factory-reconditioned units are available at a low, fixed cost after the one-year warranty expires.

* Although the information (specifications, contacts, etc.) was correct at the time of printing, anything in this manual is subject to change without notice.

