



REFRIGERATOR- FREEZER

OWNER'S MANUAL

PLEASE
READ THIS OWNER'S MANUAL THOROUGHLY
BEFORE OPERATING AND KEEP IT HANDY
FOR REFERENCE AT ALL TIMES.



GR-322-3828JD8250A

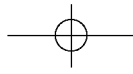

CONTENTS

CONTENTS	2
INSTALLATION	3
FEATURE CHART	4
OPERATIONS	5
ADVICE ON FOOD STORAGE	7
CARE AND CLEANING	7
LAMP REPLACEMENT	8
IMPORTANT WARNINGS	8
REPLACEMENT OF DOOR OPENING TYPE	9
BEFORE CALLING FOR SERVICE	11

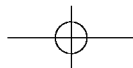
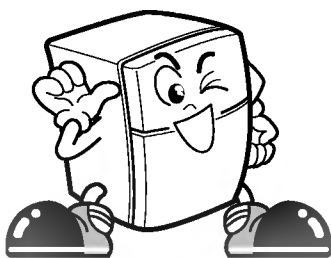
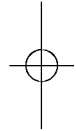

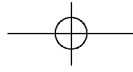

INSTALLATION

1. Place your refrigerator at a convenient location.
2. Avoid placing the refrigerator near any heat sources, direct sunlight or moisture.
3. Air must circulate properly around your refrigerator to ensure efficient operation. Allow at least a clearance of 10 inches(25cm) or more above the refrigerator and 2 inches(5cm) or more space at rear and both sides.
4. To avoid vibrations the refrigerator has to be placed on a levelled surface. If necessary, set the leveling screws to compensate for unevenness of the floor. The front should be slightly higher than the rear so the door would close more easily.
5. Clean your refrigerator thoroughly and wipe off all dust accumulated during transportation.
6. Connect the power supply cord to the outlet. Don't plug other appliances to the same outlet.
7. Leave your refrigerator on for an hour or so. And check the flow of cold air in the freezer compartment. Your refrigerator is now ready for use.

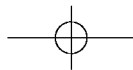
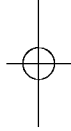
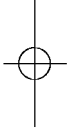

FEATURE CHART

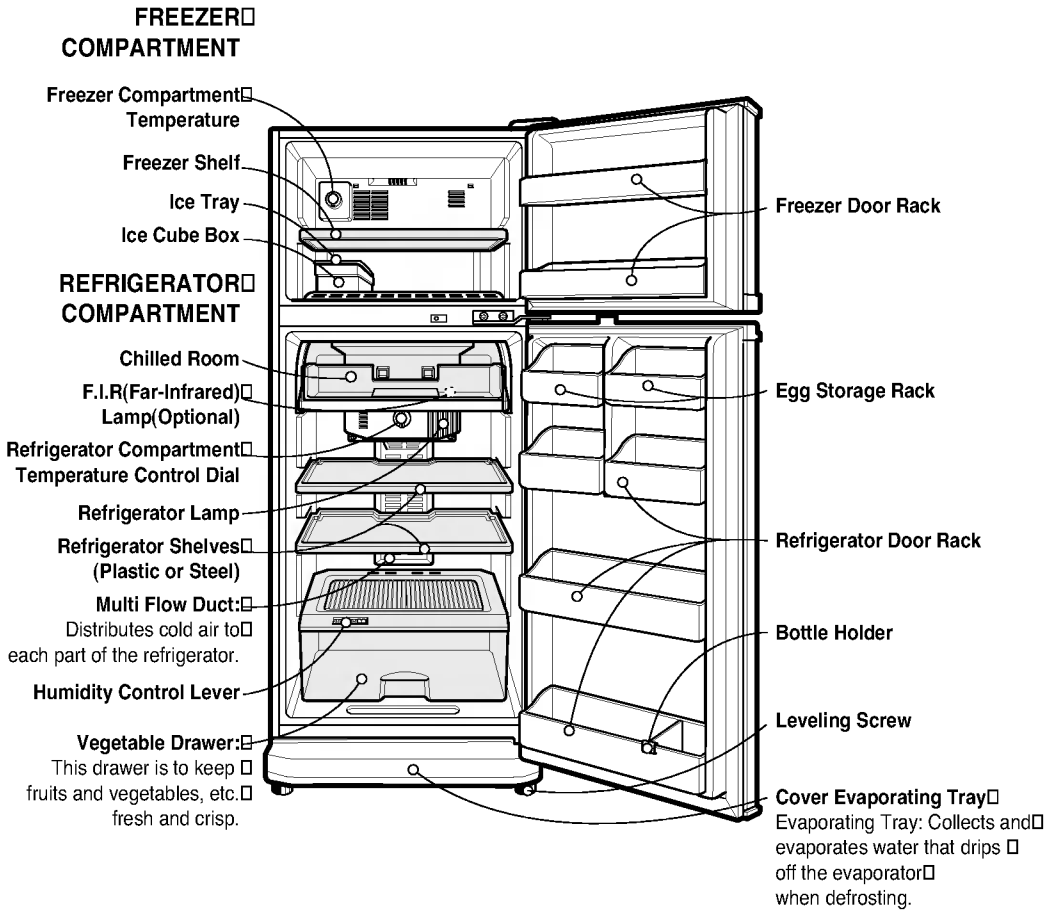

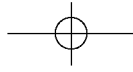

OPERATION

STARTING

When your refrigerator is first installed, leave it for 2 or 3 hours for stabilization to normal operating temperature before filling it with food.

Delay 5 minutes before restarting if operation has been interrupted.

TEMPERATURE CONTROL

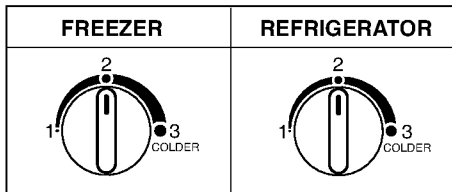

Initially, set the freezer and/or refrigerator compartment control at "2"(mid position).

If you wish a colder temperature, set the desired compartment control to a higher number.

ICE MAKING

- To make ice cubes, fill the ice tray with water and place it in the freezer.
- To remove ice cubes, gently twist the tray while holding it at its ends.

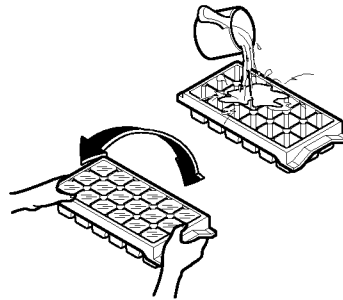

DEFROSTING

Defrosting takes place automatically. The defrosting water flows down to the evaporating tray and is evaporated automatically. Evaporating tray should be cleaned regularly.

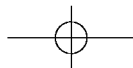

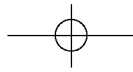

OPERATION

F.I.R LAMP(OPTION)

The emitted rays from the Far Infrared Lamp(F.I.R) prevents food from getting dry, and therefore prolongs the foods freshness. It also increases the nucleic acid in the food which helps to protect the smell and taste of the food.

MORE EFFECTIVE FOOD STORAGE

- F.I.R is ideal for storing unseasoned and raw meats, raw fish, poultry, etc.
- It is excellent for keeping fruit and vegetables fresh for longer as the F.I.R prevents excessive fermentation and over-ripening.
- It is also useful for the storage of delicate foods which are unsuitable for the freezer such as boiled eggs, bamboo shoots or vegetables used in condiment.

OPERATING

- The F.I.R lamp is automatically controlled by the internal temperature. It is not necessary to operate manually.
- The F.I.R lamp has a special coating to make it effective.
- If the lamp is covered by anything, the efficiency will be reduced.
- Better results will be obtained if foods are covered with cling film, rather than being stored in containers with lids.
- To check the operation of the lamp, press the door switch for the refrigerator compartment in, and you should see light coming from the un-coated part of the lamp.



- Do not touch the lamp when it is in operation. As the surface is extremely hot.

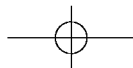

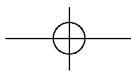

ADVICE ON FOOD STORAGE

- Never store hot food in the refrigerator. Always wait until cooled off.
- When storing, cover food with vinyl wrap or store in a container with lid.
When moisture in the food evaporates, taste and nutrition of the food disappear as well.
- Never place bottles in the freezer compartment. They may break while freezing.
- Never refreeze food that has been thawed after being frozen.
This would cause the taste and nutrition to disappear.
- Clean food before you store it, so that adjacent food will not be spoiled.

CARE AND CLEANING

CLEANING - INSIDE

To clean the inside, use a soft cloth dampened with solution of a tablespoon of baking soda to a quarter of water, or some mild detergent.

This solution both cleans and neutralizes odors. Rinse with water and wipe dry.

Follow the same procedure to clean the interior parts.

CLEANING - OUTSIDE

Use a lukewarm solution of mild soap or detergent to clean the durable finish of your refrigerator. Wipe with a clean, dampened cloth, then dry.

CLEANING - CAUTIONS

- Always remove the power cord from the electrical outlet before cleaning near electrical parts.
- Never use flammable or toxic cleaning liquids.
- Do not use metallic scouring pads, brushes, coarse abrasive cleaners or strong alkaline solutions on any surface of the refrigerator.
- When you leave for vacation:
For extended vacations, disconnect the power cord and leave the door open. This will prevent odors.
For shorter vacations, remove perishable foods. Leave the control to normal operation.
- When moving:
Secure all loose items by taping them in place to prevent from being damaged, and raise the leveling screw.

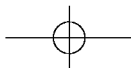

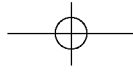

LAMP REPLACEMENT

A lamp is located as shown in the feature chart.

To replace the lamp, unplug the refrigerator from its electrical outlet, turn the lamp counterclockwise after removing the lid as shown in the figure, and replace it with a lamp featuring the same characteristics.

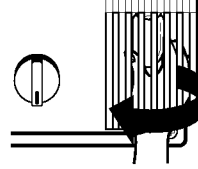

IMPORTANT WARNINGS

DO NOT USE AN EXTENSION CORD

If possible, connect the refrigerator to its own individual electrical outlet in order to avoid an overload caused by other appliances or household lights that might interrupt the electrical current.

POWER CORD REPLACING INSTRUCTIONS

If the supply cord is damaged, it must be replaced by a special cord or assembly available from the manufacturer or its service agent.

An empty refrigerator constitutes a very dangerous attraction to children.
Do not forget to remove the door from unused refrigerator.

ABOUT GROUNDING(EARTHING)

Grounding(earthing) reduces the risk of electric shock by providing an escape wire for the electric current in case of an electric short circuit.

Improper use of the grounding plug may cause an electric shock. Check with a qualified electrician or a service person if the grounding instructions are not understood, or if you have doubts on whether the appliance is properly grounded.

CAUTION: THIS APPLIANCE MUST BE GROUNDED.

Do not store inflammable materials, explosives or chemicals in the refrigerator.

Do not touch the frozen surface, especially if your hands are wet or damp. It may cause frostbite.

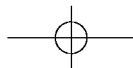

REPLACEMENT OF DOOR OPENING TYPE

- Converting Door is Optional

PRECAUTION

1. Before replacing the door opening type, first of all, you should take out of foodstuffs and accessories like shelves or trays, and so on which are not fixed in the refrigerator.
2. Use the '+' Driver, Bolt Driver, Torque Wrench or Spanner to fix or remove the bolt.
3. Be careful not to fall down the refrigerator in disassembling or assembling the Hinge Lower and the Adjustable Screw Asm. Don't lay the refrigerator down in working with it, it will cause to get out of order.
4. Be careful not to drop the door in disassembling or assembling the freezer or the refrigerator door.
5. This refrigerator, according to the install position or user's liking, can be used as the type of opening from the right or the left.

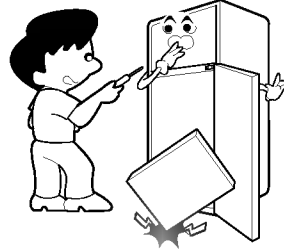

HOW TO REPLACE THE DOOR OPENING TYPE (when converting from the left-opening type to right opening type)

1 Separate the Cap ① and Hinge Upper ②.

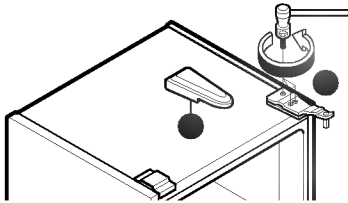

2 Separating the Freezer Door ③.

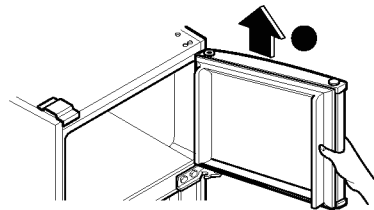

3 Separating the Hinge-C ④ and the Refrigerator Door ⑤.

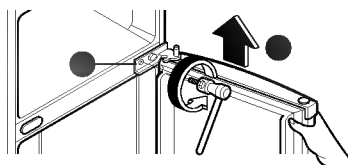

4 Separating the Hinge Lower ⑥.

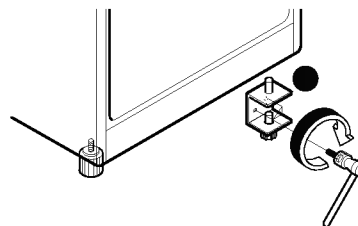

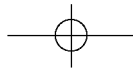

REPLACEMENT OF DOOR OPENING TYPE

5 Move the Position of Adjustable Screw Assembly ⑦.

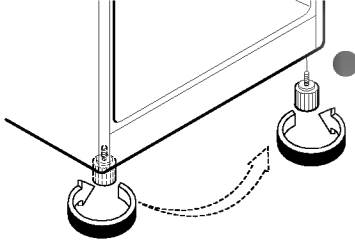

6 Assemble the Hinge Lower ⑥.

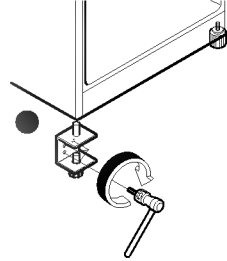

7 Move the Cap ⑧, Bracket ⑨ of the Refrigerator Door.

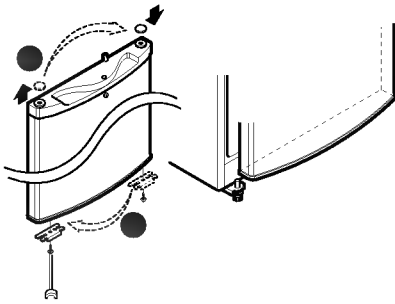

8 Move the Cap ⑩ and Assemble the Hinge-C ④.

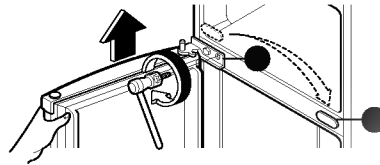

9 Assemble the Door Stopper-F ① for Right Opening Type.

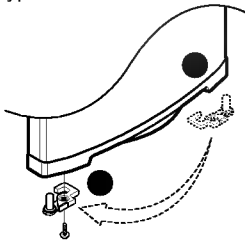

10 Move the Cap ⑫ and Assemble the Freezer Door ③.

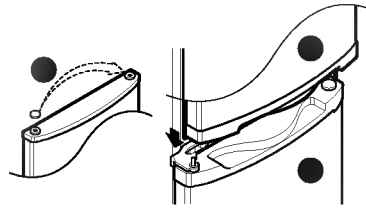

11 Move the Pin Position ⑬ of the Hinge Upper.

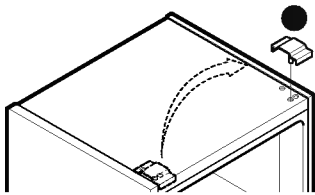

12 Assemble the Hinge Upper ② and the Cap ①.

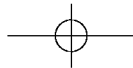
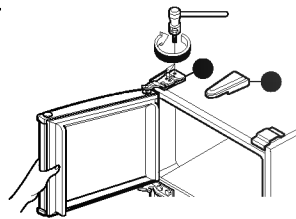

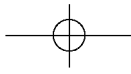

BEFORE CALLING FOR SERVICE

It is often possible to avoid a service call. Before calling for service, make the following checks.

- Has a house fuse blown or a circuit breaker tripped on?
- Has the power cord plug been removed or loosened from the wall outlet?
- Is the temperature control set to a proper position?
- Is the appliance placed too close to a wall or a heat source?
- Has the door been kept open more than necessary?
- Is the refrigerator installed on a firm and even place?
- In case of odor. Food with strong odor should be tightly covered or wrapped, and interior may need cleaning.

