



Micro Hi-Fi System OWNER'S MANUAL

**MODELS: LX-M140A/X/D
LXS-M140**



**Please read this manual carefully before operating
your set.**

Retain it for future reference.

**Designs and specifications are subject to change
without notice for improvement.**



Precautions

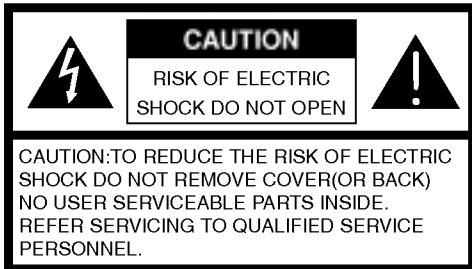

Explanation Graphical Symbols:



The lightning flash with arrowhead symbol, within an equilateral triangle is intended to alert the user to the presence of uninsulated dangerous voltage within the product's enclosure that may be of sufficient magnitude to constitute a risk of electric shock to persons.



The exclamation point within an equilateral triangle is intended to alert the user to the presence of important operating and maintenance (servicing) instructions in the literature accompanying the appliance.

WARNING

TO REDUCE THE RISK OF FIRE OF ELECTRIC SHOCK, DO NOT EXPOSE THIS APPLIANCE TO RAIN OR MOISTURE.

To avoid electrical shock, do not open the cabinet, Refer servicing to qualified personnel only.

The apparatus shall not be exposed to dripping or splashing and that no objects filled with liquids, such as vases, shall be placed on the apparatus.

Warning:

Do not install this equipment in a confined space such a book case or similar unit.

CAUTION

Use of controls or adjustments or performance of procedures other than those specified herein may result in hazardous radiation exposure.

Laser component in this product is capable of emitting radiation exceeding the limit for Class 1.

CAUTION: INVISIBLE LASER RADIATION WHEN OPEN AND INTERLOCKS DEFEATED. AVOID EXPOSURE TO BEAM.

VARNING: OSYNLIG LASERSTRÅLNING NÄR DENNA DEL ÄR ÖPPNAD STRÅLEN ÄR FARLIG.

Attention: Quand l'appareil est ouvert, ne pas s'exposer aux radiations invisibles du faisceau laser.

This label is located on the interior.

CLASS 1	LASER PRODUCT
KLASSE 1	LASER PRODUKT
LUOKAN 1	LASER LAITE
KLASS 1	LASER APPARAT
CLASSE 1	PRODUIT LASER

This Compact Disc player is classified as a CLASS 1 LASER product.

The CLASS 1 LASER PRODUCT label is located on the exterior.

This product is manufactured to comply with the radio interference requirements of EEC DIRECTIVE 89/336/EEC, 93/68/EEC and 73/23/EEC.

Table of Contents

INTRODUCTION

Precautions	2
Table of Contents	3
Before Use	4
Safety Precautions	4
Notes on Discs	4
Notes on Remote Control	4
Notes on Tapes	4
Adjusting the voltage (OPTIONAL)	4
Front Panel/Rear Panel	5
Remote Control	6
Display Window	6
Connections	7
Speaker System Connection	7
Antenna (Aerial) Connections	7



BEFORE OPERATION

Setting the CLOCK	8
Sleep Function	8
Auxiliary Function	8
Timer Function	9
Audio Adjustment	9
Volume Adjustment	9
XDSS	9
MUTE	9
Sound Quality Adjustment	9
RDS Function - OPTIONAL	10

OPERATION

Presetting the radio stations	11
Listening to the radio	11
Tape Playback	12
Basic Playback	12
To Stop Play	12
To Pause Play	12
To Play Fast Rewind or Fast Forward	12
Recording	12
Basic Setting	12
Recording from Radio, CD or Auxiliary source	12
CD to Tape Synchronized Recording	12
CD Playback	13
Basic Playback	13
To Pause Play	13
To Stop Play	13
To Skipping the Track	13
To Play Fast Rewind or Fast Forward	13
To Repeat Play	13
To check MP3 file information	13
To Program Play	14
About MP3	14
REFERENCE	
Troubleshooting	15
Specifications	

About the symbols for instructions

-  Indicates hazards likely to cause harm to the unit itself or other material damage.
-  Indicates special operating features of this unit.
-  Indicates tips and hints for making the task easier.

Before Use

Safety Precautions

Handling the unit

When shipping the unit

The original shipping carton and packing materials come in handy. For maximum protection, re-pack the unit as it was originally packed at the factory.

To keep the surface clean

Do not use volatile liquids, such as insecticide spray, near the unit. Do not leave rubber or plastic products in contact with the unit for a long period of time. They will leave marks on the surface.

Cleaning the unit

To clean the cabinet

Use a soft, dry cloth. If the surfaces are extremely dirty, use a soft cloth lightly moistened with a mild detergent solution. Do not use strong solvents, such as alcohol, benzene, or thinner, as these might damage the surface of the unit.

Notes on Discs

Handling discs

Do not touch the playback side of the disc. Hold the disc by the edges so that fingerprints will not get on the surface. Do not stick paper or tape on the disc.

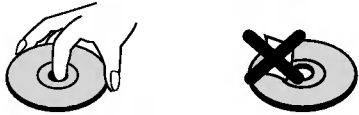

Storing discs

After playing, store the disc in its case. Do not expose the disc to direct sunlight or sources of heat, or leave it in a parked car exposed to direct sunlight, as there may be a considerable temperature increase inside the car.

Cleaning discs

Fingerprints and dust on the disc can cause poor picture quality and sound distortion. Before playing, clean the disc with a clean cloth. Wipe the disc from the center out.



Do not use strong solvents such as alcohol, benzene, thinner, commercially available cleaners, or anti-static spray intended for analog records.

Notes on Remote Control

Remote Control Operation Range

Point the remote control at the remote sensor and press the buttons.

- **Distance:** About 23 ft (7 m) from the front of the remote sensor.
- **Angle:** About 30° in each direction of the front of the remote sensor.

Remote control battery installation

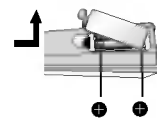

Detach the battery cover on the rear of the remote control, and insert two R03 (size AAA) batteries with + and - aligned correctly.

Caution

Do not mix old and new batteries. Never mix different types of batteries (standard, alkaline, etc.).

Notes on Tapes

Preventing overwriting a recording

Removing the safety tab(s) of the cassette (with a small screwdriver) will prevent accidental erasure.

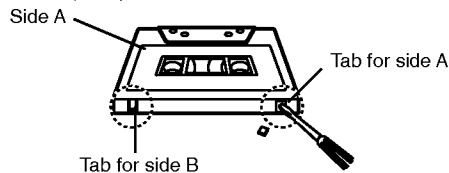

To record again, cover the hole of the tab with adhesive tape.

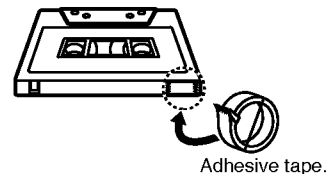

Adjusting the voltage (OPTIONAL)

If your unit is equipped with a voltage selector at the back side, be sure to set it to your local power supplied before connecting the AC power cord.

Front Panel/Rear Panel

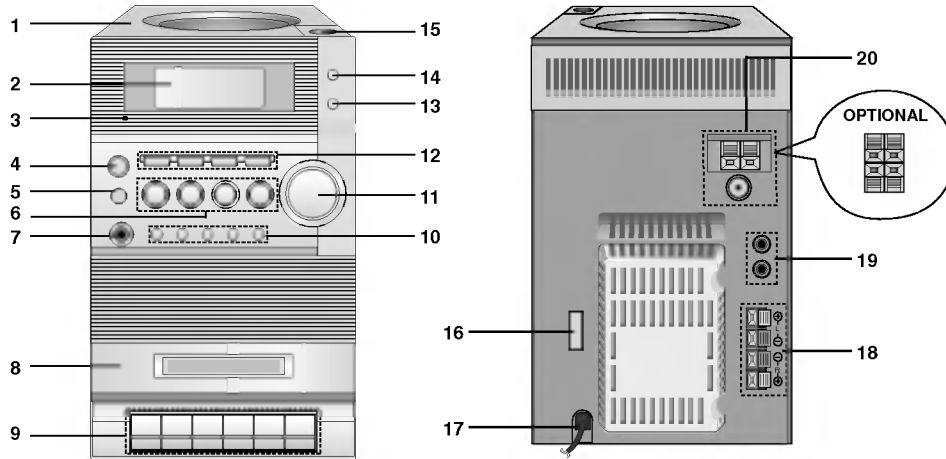

1. CD DOOR
2. DISPLAY
3. POWER indicator
4. POWER (STANDBY/ON) button
5. Remote Control Sensor
6. • CD PLAY/PAUSE (CD ►/||) button
 - TUNING (▼/▲) buttons - TUNER
 - CD SKIP/SEARCH (◀◀◀/▶▶▶) buttons
 - PRESET (▼/▲) buttons
7. HEADPHONE SOCKET (PHONES): ∅3.5mm
8. CASSETTE Holder
9. • RECORD (●) button - TAPE
 - PLAY (►) button - TAPE
 - REWIND (◀◀) button - TAPE
 - FAST FORWARD (▶▶) button - TAPE
 - STOP/EJECT(■/▲) button - TAPE
 - PAUSE (||) button - TAPE
10. • CLOCK button
 - TIMER button
 - REPEAT button
 - PROGRAM/MEMORY button
 - (■)STOP/CLEAR button
11. VOLUME CONTROL KNOB
12. • FUNCTION SELECT (FUNCTION) button
 - (TUNER/ CD/ TAPE /AUX)
 - TUNER/BAND button
 - RDS (OPTIONAL)/SET button
 - MODE/RIF button
13. EQUALIZER PATTERN (EQ) button
14. XDSS button
15. CD OPEN/CLOSE (▲OPEN/CLOSE) button
16. VOLTAGE SELECT SWITCH : OPTIONAL
17. POWER CORD
18. SPEAKER TERMINAL
19. AUXILIARY INPUT SOCKET (AUX)
20. ANTENNA TERMINAL

INTRODUCTION

Remote Control

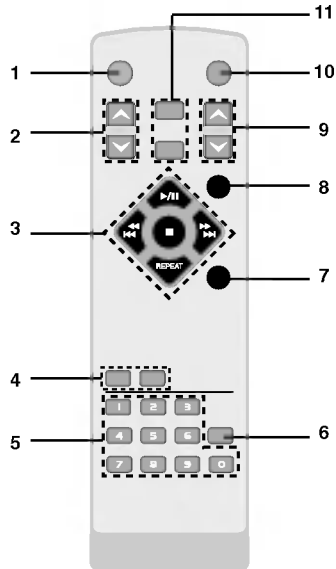

1. POWER button
2. PRESET (▼/▲) button
3. CD FUNCTION buttons
 - CD PLAY/ PAUSE (▶/⏸) button
 - CD STOP(■) button
 - CD SKIP/SEARCH (◀◀ ◀▶/▶▶▶▶) buttons
 - REPEAT button
4. • EQUALIZER PATTERN (EQ PATT.) button
 - XDSS button
5. NUMBER buttons
6. MP3 file information display (MP3 Info) button
7. PROGRAM button
8. SLEEP button
9. VOLUME CONTROL (▼/▲) button
10. MUTE button
11. • TUNER/BAND button
 - AUX button

Display Window

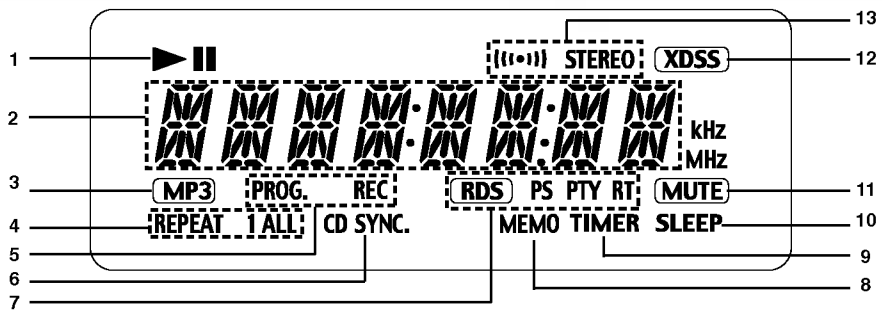

1. PLAY/ PAUSE indicator
2. FUNCTION indicators
3. MP3 indicator
4. CD REPEAT indicator
5. • PROGRAM indicator
 - RECORD/ RECORD PAUSE indicator
6. CD SYNCHRO RECORDING indicator
7. RDS indicator : OPTIONAL
8. MEMORY indicator
9. TIMER indicator
10. SLEEP indicator
11. MUTE indicator
12. XDSS indicator
13. • FM STEREO indicator
 - FM STEREO RECEIVING indicator



Connections

Speaker System Connection

Connect the speaker cords to the speaker terminals.

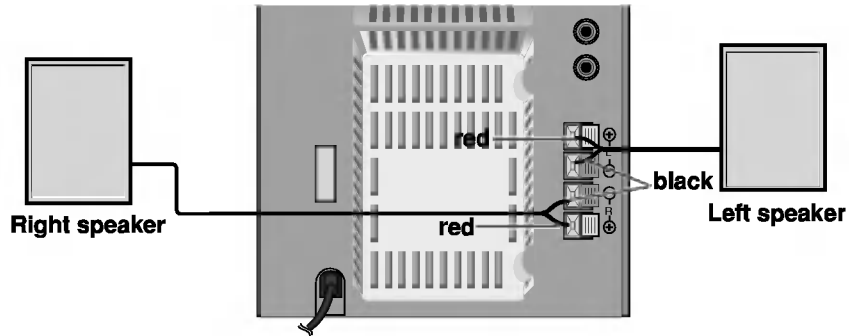

Notes

- Be sure to match the speaker cord to the appropriate terminal on the components: + to + and - to -. If the cords are reversed, the sound will be distorted and will lack base.
- If you use front speakers with low maximum input rating, adjust the volume carefully to avoid excessive output on the speakers.
- Do not disassemble the front cover of supplied speaker.

Antenna (Aerial) Connections

Connect the supplied FM/AM antennas for listening to the radio.

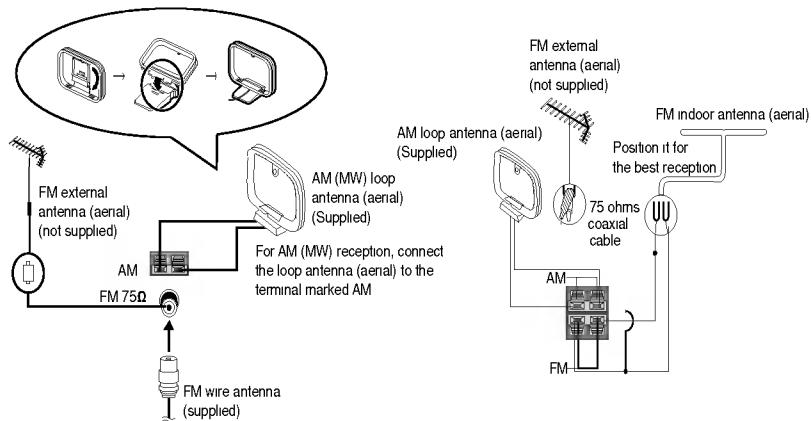

Notes

- To prevent noise pickup, keep the AM loop antenna away from the unit and other components.
- Be sure to fully extend the FM wire antenna.
- After connecting the FM wire antenna, keep it as horizontal as possible.

Setting the CLOCK

- 1** Press **CLOCK**.
(If the clock requires setting, press and hold **CLOCK** for more than 2 seconds.)
- The hours begin to flash.
- 2** Select a 12 hour cycle or 24 hour cycle by pressing **TUNING** (\vee/\wedge) on the front panel.

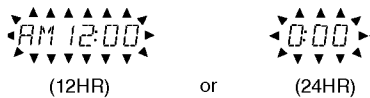

- 3** Press **SET** to confirm the selected hour cycle.

- 4** Use **TUNING** (\vee/\wedge) buttons to set the correct hours on the front panel.

- 5** Press **SET**.

- 6** Use **TUNING** (\vee/\wedge) buttons to set the correct minutes on the front panel.

- 7** Press **SET** and the correct time is shown on the display.

- 8** Press **CLOCK** at any time to display the time for about 3 seconds.

Note

The unit can also set the clock function in power off state.

Sleep Function

When the sleep timer is used, the power is automatically turned off after the specified time has elapsed.

- 1** To specify the time delay before the power is turned off, press **SLEEP**.
In the display window you can see *SLEEP 90* for about 5 seconds. This means that the system turns off automatically after 90 minutes.
Each time the button is pressed the time interval before it turns off is reduced by 10 minutes. i.e. 80...70... etc.
Select the desired time to turn off.

Note

If you press **SLEEP** while the sleep time is displayed, the **SLEEP** time is reset.

To cancel the sleep timer mode

If you wish to stop the function, press the **SLEEP** button repeatedly until "SLEEP 10" appears, and then press **SLEEP** once again while "SLEEP 10" is displayed.

- 2** To check the remaining time until the power is turned off.
While the sleep function is active press **SLEEP** briefly. The time remaining until it turns off is displayed for about 5 seconds.

Auxiliary Function

- 1** Connect an auxiliary device i.e. TV or VCR, via the rear mounted AUX phone sockets.
- 2** Press **AUX**.

Note

You can also record from the auxiliary input source, see Recording Section.



Timer Function

With the **TIMER** function you can have the radio reception and recording, CD play, auxiliary source play and recording turned on and off at the time desired.

1 Press **CLOCK** to check the current time.

For your reference

If you don't set clock, timer function doesn't work.

2 Press **TIMER** to enter the timer setting mode.
TUNER-CD flashes in the display window in turn.

For your reference

If you want to correct the previous memorized **TIMER** setting, press and hold the **TIMER** button more than 2 seconds.

- The previous memorized timer on time and "TIMER" indicators appear in the display.

3 Press **SET** when the desired function is flashing.

4 When you select the **TUNER** or **CD** function.
- "ON TIME" indicator appears for about 0.5 seconds in the display window and then disappears.

5 Set the hour to switch on by pressing **TUNING** (\vee/\wedge) buttons on the front panel.

6 Press **SET** to confirm the hour to switch on.

7 Set the minute to switch on by pressing **TUNING** (\vee/\wedge) buttons on the front panel.

8 Press **SET** to confirm the minute to switch on.
"OFF TIME" indicator appears for about 0.5 seconds in the display window and then disappears.

9 Set the hour to switch off by pressing **TUNING** (\vee/\wedge) buttons on the front panel.

10 Press **SET** to confirm the hour to switch off.

11 Set the minute to switch off by pressing **TUNING** (\vee/\wedge) buttons on the front panel.

12 Press **SET**.

13 Adjust the volume level by pressing **TUNING** (\vee/\wedge) buttons on the front panel.

14 Press **SET**.
"TIMER" appears in the display window and the timer setting has been completed.

15 Switch the system off.
The selected function is automatically switched on and off at the time set.

To cancel or check the timer

Each time the **TIMER** button is pressed you can select the timer set or cancel. You can also check the timer setting status.

To activate or check the timer, press the **TIMER** button so that "TIMER" appears in the display window. To cancel the **TIMER**, press the **TIMER** button so that "TIMER" disappears in the display window.

Note

The unit can also set the clock function in power off state.

Audio Adjustment

Volume Adjustment

- Press **VOLUME CONTROL KNOB** clockwise to increase the sound level, or counterclockwise to decrease it on the front panel.
- Press **VOLUME CONTROL** (\blacktriangle) to increase the sound level, or press the **VOLUME CONTROL** (\blacktriangledown) to decrease it on the remote control.

XDSS (Extreme Dynamic Sound System)

Press **XDSS** to reinforce treble, bass and the surround effect. The "XDSS ON" or "XDSS OFF" indicator lights. To cancel, press **XDSS** again.

MUTE

Press **MUTE** to mute your unit.
You can mute your unit in order, for example, to answer the telephone, "MUTE" indicator flashes in the display window.

Sound Quality Adjustment

• To activate stereo sound

You can choose between 4 fixed sound impressions. Select a desired sound mode by using the **EQ PATT.** button.

FLAT : linear frequency response
ROCK : more bass, more treble
POP : less bass, less treble
CLASSIC : for orchestral music

• Headphone Socket

Connect a stereo headphone plug (\varnothing 3.5mm) into the headphone jack.

The speakers are automatically disconnected when you plug in the headphones (not supplied).

RDS Function - OPTIONAL

About RDS

This unit is equipped with RDS (Radio Data System), which brings a wide range of information from FM radio. RDS is a system for transmitting station call signs or network information, a description of station programme type text message about the station or specifics of musical selection and the correct time.

RDS Tuning

When a FM station containing RDS data is tuned in, the unit will automatically display the station's call sign and the RDS indicator will light in the Display Window as well as indicators for the programme type recognition (PTY), Radio Text (RT), Clock Time (CT) and RDS services programme (PS) if transmitted by the station.

RDS Display Options

The RDS system is capable of transmitting a wide variety of information in addition to the initial call sign that appears when a station is first tuned. In normal RDS operation the display will indicate the station name, broadcast network or call letters. Pressing **RDS** on the front panel enables you to cycle through the various data types in the sequence:

(PS → FREQUENCY → PTY → RT → CT)

- **PTY (Programme type recognition)**- The programme type is shown on the display window.
- **RT (Radio text recognition)**- The radio station's name is displayed on the display window.
- **CT (Time controlled by the channel)**- Enable the unit to receive the actual time and show it on the display window.
- **PS (Programme Service name)**- The programme title is displayed on the display window.

Note

Some RDS stations may not choose to include some of these additional features. If the data required for the selected mode is not being transmitted, the Display Window will show a **PTY NONE**, **RT NONE**, **CT NONE**, **PS NONE** message.

Programme Search (PTY)

A major benefit of RDS is its ability to encode broadcasts with Programme Type (PTY) codes that indicate the type of material being broadcast. The following list shows the abbreviations used to indicate each PTY along with an explanation of the PTY.

NEWS	News
AFFAIRS	Current Affairs
INFO	Information
SPORT	Sports
EDUCATE	Educational
DRAMA	Drama
CULTURE	Culture
SCIENCE	Science
VARIED	Varied Speech Programme
POP M	Popular Music
ROCK M	Rock Music
EASY M	Easy Listening Music
LIGHT M	Classical Music
CLASSICS	Serious Classical Music
OTHER M	Other Music
WEATHER	Weather Information
FINANCE	Financial Programmes
CHILDREN	Children's Programmes
SOCIAL	Social Affairs Programmes
RELIGION	Religious Broadcasts
PHONE IN	Phone-In Programmes
TRAVEL	Travel and Touring
LEISURE	Leisure and Hobby
JAZZ	Jazz Music
COUNTRY	Country Music
NATION M	National Music
OLDIES	Oldies Music
FOLK M	Folk Music
DOCUMENT	Documentary Programmes
TEST	Station Alarm Test Message
ALARM 1	Emergency Broadcast Information

You may search for a specific Programme Type (PTY) by following these steps:

- 1** Press **TUNER/BAND** to select FM mode.
- 2** Select a desired station by pressing **TUNING (√ / ^)**.
When the RDS transmission is received, the display shows the program service name (PS) after RDS indicator appears.
- 3** Press the **RDS** to select PTY mode.
- 4** To search for a different PTY, press the **PRESET (√ / ^)** while the last PTY in use is still displayed to scroll through the list of available PTY types.
- 5** When the PTY is selected, press the **◀◀◀ / ▶▶▶** within 5 seconds.
The unit will go into an automatic search mode and attempt to find the next station with acceptable signal strength that matches the desired PTY type.



Presetting the radio stations

You can preset 50 stations for FM and AM. Before tuning, make sure that you have turned down the volume to the minimum.

1 Press **TUNER/BAND** to select the FM or AM you want in the display window.
Every time you press TUNER/BAND, FM and AM changes alternately.

2 Press **TUNING (∇/\wedge)** on the front panel until the frequency indication starts to change, then release.
Scanning stops when the unit tunes in a station.

Notes

• Tuning in automatically

Press **TUNING (∇/\wedge)** for more than 0.5 seconds.

• Tuning in manually

Press **TUNING (∇/\wedge)** briefly and repeatedly.

3 Press **PROGRAM/MEMORY** on the front panel. A preset number will flash in the display window.

4 Press **PRESET (∇/\wedge)** (or **PRESET (∇/\wedge)** on the remote control) to select the preset number you want.

5 Press **PROGRAM/MEMORY**.
- The station is stored.

6 Repeat steps 3 to 6 to store other stations.

To clear all the memorized stations

Press and hold **PROGRAM/MEMORY** on the front panel for about two seconds, "CLEAR" appears in the display window and then press **CLEAR**, the stations are cleared.

For your reference

If all stations have already been entered, FULL message will appear in the display window for a moment and then a preset number will flash. To change the preset number, follow the steps 5-6.

To recall presets

Press and hold **PRESET (∇/\wedge)** (or **PRESET (∇/\wedge)** on the remote control) until the desired preset number appears or press it repeatedly.

Listening to the radio

1 Press **TUNER/BAND** to select the FM or AM you want in the display window.
The last received station is tuned in.

2 Press **PRESET (∇/\wedge)** (or **PRESET (∇/\wedge)** on the remote control) repeatedly to select the preset station you want.
- Each time you press the button, the unit tunes in one preset station at a time.

3 Adjust the volume by pressing **VOLUME CONTROL KNOB** on the front panel or **VOLUME (∇/\wedge)** on the remote control repeatedly.

To listen to non-preset radio stations

- Use manual or automatic tuning in step 2.
- For automatic tuning, press and hold **TUNING (∇/\wedge)** on the front panel.

To turn off the radio

Press **POWER** to turn the unit off or select another function mode (CD, TAPE or AUX).

For your reference

• If an FM program is noisy

Press **MODE/RIF** so that "STEREO" disappears in the display window. There will be no stereo effect, but the reception will improve. Press **MODE/RIF** again to restore the stereo effect.

• To improve reception

Reposition the supplied antennas.

Notes

- Use **MODE/RIF** (Radio Interference Filter) function to switch to mono reception if stereo reception is distorted by noise.
- When recording the MW(AM) broadcast, beat noises may occur. If it does, press **MODE/RIF** once.

Tape Playback

Basic Playback

- 1 Press **FUNCTION** repeatedly to appear **TAPE** indicator.
- 2 Open cassette deck by pushing **STOP/EJECT** (■/▲) button.
- 3 Insert a cassette with the tape side to the bottom and then close deck.
- 4 Press **PLAY** (▶).

To Stop Play

Press **STOP/EJECT** (■/▲) during playback.

To Pause Play

Press **PAUSE** (||) during playback.
Press this button again it to resume play.

To Play Fast Rewind or Fast Forward

After pressing **REWIND/FAST FORWARD** (◀◀/▶▶) on the front panel during playback or stopping.

AUTO STOP DECK

After auto stop deck plays only front side, the unit stops automatically.

Recording

Wind the tape to the point recording starts. (Use only normal tapes.)

Basic Setting

- 1 Select the function (**MP3/CD**, **TUNER/BAND** or **AUX**) you want to record.
- 2 Open the cassette deck and insert a blank cassette into the cassette compartment.

Recording from Radio, CD or Auxiliary source

- 1 Press **FUNCTION** button to select desired recording source, and then press **RECORD** (●) button.
The recording begins.

For your reference

When you press **RECORD** (●) button, **PLAY** (▶) button is pressed automatically.

2 To pause recording

- Press **PAUSE** (||) button during recording.
- Press **PAUSE** (||) button again to resume recording.

3 To stop recording

Press **STOP/EJECT** (■/▲).

CD to Tape Synchronized Recording

The CD synchro recording function dubs a complete CD and programmed titles automatically into a cassette.

- 1 When you select **CD** function, press **RECORD** (●) button.
"REC" appears and "CD SYNC" displays in the display window.

2 The synchronized recording is started automatically after about 8 seconds.

Notes

- If you wish to record from the desired track, select the desired track with **CD SKIP/SEARCH** (◀◀◀◀ / ▶▶▶▶) before commencing CD synchro recording.
- The function change is not possible during recording.

CD Playback

Basic Playback

- 1** Press **FUNCTION** repeatedly to appear CD indicator.
If no disc is loaded then "NO DISC" is displayed.
- 2** Press **CD OPEN/CLOSE** (**▲OPEN/ CLOSE**) and place the disc into the disc tray.
Note
To load an 8cm(3 inch) disc, put it onto the inner circle of the tray.
- 3** Press **CD OPEN/CLOSE** (**▲OPEN/ CLOSE**) to close the disc compartment.
Audio CD: "READING" appears in the display window, and then the total number of tracks and the playing time are displayed.
MP3 CD: "READING" appears in the display window, and then the total number of files is displayed.
- 4** Press **CD PLAY/ PAUSE** (**▶/||**).

To Pause Play

Press **CD PLAY/ PAUSE** (**▶/||**) during playback.
Press this button again it to resume play.

To Stop Play

Press **CD STOP** (**■**) during playback.

To Skipping the Track

- Press the **CD SKIP/SEARCH** (**▶▶ ▶▶**) button to go to the next track.
- When the **CD SKIP/SEARCH** (**◀◀ ◀◀**) button is pressed once midway through a track, the player returns to the start of that track. When it is pressed again, a track is skipped each time the button is pressed.

To Play Fast Rewind or Fast Forward

After pressing **CD SKIP/SEARCH** (**◀◀ ◀◀** / **▶▶ ▶▶**) buttons for more the 2 seconds on the front panel, then release during playback, press **PLAY** (**▶/||**) at the point you want.

Note

This function is not available to play a MP3 file.

To Repeat Play

To play one track repeatedly

Press **REPEAT** once during playback.
- "REPEAT 1" appears in the display.

To play all tracks repeatedly

Press **REPEAT** again during playback.
- "REPEAT ALL" appears in the display.

To cancel repeat play

Press **REPEAT** once more during playback.
- "Repeat indicator" disappears.

To check MP3 file information

Press the **MP3 Info** button during MP3 file playback.

- The information (Title, Artist or Album) of the MP3 file will be shown in the display window.
- If there is no information of the MP3 file, "NO ID3 TAG" indicator will be shown in the display window.
- The "MP3 file name" and "ID3 TAG" should be named using English.

Note

This unit can play a CD-R or CD-RW that contains audio titles or MP3 files.

CD Playback

To Program Play

You can arrange the order of the tracks on the discs and create your own program. The program can contain up to 20 tracks.

- 1** Press PROGRAM/MEMORY (or PROGRAM on the remote control) on the stop mode.
- 2** Press CD SKIP/SEARCH (◀◀◀/▶▶▶) buttons to select the track you want.
- 3** Press PROGRAM/MEMORY (or PROGRAM on the remote control).
- 4** Repeat 1-3.
- 5** Press CD PLAY/ PAUSE (▶/||).

To check program contents

Press PROGRAM/MEMORY (or PROGRAM on the remote control) on the stop mode.
- A track and program number will be displayed.

To clear program contents

Press PROGRAM/MEMORY (or PROGRAM on the remote control) on the stop mode. And then press (■)STOP/CLEAR on the front panel or STOP(■) on the remote control.

To add program contents

1. Press PROGRAM/MEMORY (or PROGRAM on the remote control) repeatedly on the program stop mode until "Track Number" blinks.
2. Repeat 2-5.

To modify program contents

1. Press the PROGRAM/MEMORY (or PROGRAM on the remote control) to display program number you want to modify.
2. Repeat 2-4.

About MP3

- An MP3 file is audio data compressed by using the MPEG1 audio layer-3 file-coding scheme. We call files that have the ".mp3" file extension "MP3 files".
- The unit can not read an MP3 file that has not ".mp3" file extension.

MP3 Disc compatibility with this unit is limited as follows:

1. Sampling Frequency / 8 - 48kHz
2. Bit rate / 8 - 320kbps
3. CD-R physical format should be "ISO 9660"
4. If you record MP3 files using the software which cannot create a FILE SYSTEM, for example "Direct-CD" etc., it is impossible to playback MP3 files. We recommend that you use "Easy-CD Creator", which creates an ISO9660 file system.
5. File names should be named using 30 letters or less and must incorporate ".mp3" extension
e.g. "*****.MP3".
6. Do not use special letters such as "/ : * ? " < > " etc.
7. Even if the total number of files on the disc have more than 1000, it will only be shown up to 999.

About MULTI SESSION

- This function recognizes the multi session disc according to a disc of CD-ROM type.
ex) If there are MP3 files in the first session, the MP3 file in the first session is only played.
If there are only MP3 files in the whole session, all of the MP3 files in the session are played.
If there is Audio CD in the first session, only the Audio CD in the first session is played.



Troubleshooting

Check the following guide for the possible cause of a problem before contacting service.

Symptom	Cause	Correction
No power.	<ul style="list-style-type: none"> The power cord is disconnected. 	<ul style="list-style-type: none"> Plug the power cord into the wall outlet securely.
No sound.	<ul style="list-style-type: none"> The audio cables are not connected securely. 	<ul style="list-style-type: none"> Connect the audio cable into the jacks securely.
	<ul style="list-style-type: none"> The power of the external source equipment is switched off. 	<ul style="list-style-type: none"> Switch on the external source equipment.
The unit does not start playback.	<ul style="list-style-type: none"> No disc or tape is inserted. 	<ul style="list-style-type: none"> Insert a disc or tape.
	<ul style="list-style-type: none"> An unplayable disc or tape is inserted. 	<ul style="list-style-type: none"> Insert a playable disc or tape.
	<ul style="list-style-type: none"> The disc is placed upside down. 	<ul style="list-style-type: none"> Place the disc with the playback side down.
	<ul style="list-style-type: none"> The disc is not placed within the guide. 	<ul style="list-style-type: none"> Place the disc on the disc tray correctly inside the guide.
	<ul style="list-style-type: none"> The disc is dirty. 	<ul style="list-style-type: none"> Clean the disc.
The remote control does not work properly.	<ul style="list-style-type: none"> The remote control is not pointed at the remote sensor of the unit. 	<ul style="list-style-type: none"> Point the remote control at the remote sensor of the unit.
	<ul style="list-style-type: none"> The remote control is too far from the unit. 	<ul style="list-style-type: none"> Operate the remote control within about 23 ft (7 m).
	<ul style="list-style-type: none"> There is an obstacle in the path of the remote control and the unit. 	<ul style="list-style-type: none"> Remove the obstacle.
	<ul style="list-style-type: none"> The batteries in the remote control are exhausted. 	<ul style="list-style-type: none"> Replace the batteries with new ones.

Specifications

[General]	Power supply	Refer to the back panel of the unit.	
	Power consumption	20W	
	Mass	3kg	
	External dimensions (WxHxD)	146 X 234 X 251mm	
[CD]	Frequency response	40 - 18000 Hz	
	Signal-to-noise ratio	60 dB	
	Dynamic range	60 dB	
[Tuner]	FM	Tuning Range	87.5 - 108.0 MHz or 65 - 74 MHz, 87.5 - 108.0 MHz
		Intermediate Frequency	10.7 MHz
		Signal to Noise Ratio	55/50 dB
		Frequency Response	60 - 10000 Hz
	AM (MW)	Tuning Range	522 - 1611 kHz or 530 - 1610 kHz
		Intermediate Frequency	450 kHz
		Signal to Noise Ratio	35 dB
		Frequency Response	100 - 1800 Hz
[Amp]	Output Power	5W + 5W	
	T.H.D	0.5%	
	Frequency Response	60 - 20000 Hz	
	Signal-to-noise ratio	60 dB	
[TAPE]	Tape Speed	4.75cm/sec	
	Wow Flutter	0.25% (MTT -111, JIS-WTD)	
	F.F/REW Time	120sec (C-60)	
	Frequency Response	250 - 8000Hz	
	Signal to Noise Ratio	43dB	
	Channel Separation	50dB(P/B)/45dB(R/P)	
	Erase Ratio	55dB (MTT-5511)	
[Speakers]	Type	1 Way 1 Speaker	
	Impedance	4 Ω	
	Frequency Response	100 - 18000 Hz	
	Sound Pressure Level	88 dB/W (1m)	
	Rated Input Power	5W	
	Max. Input Power	10W	
	Net Dimensions (WxHxD)	146 x 234 x 182mm	
	Net Weight (1EA)	1.4kg	

Designs and specifications are subject to change without notice.