



website : <http://www.LGService.com>  
e-mail : <http://LGService.com/techsup.html>

# WASHING MACHINE SERVICE MANUAL

## **CAUTION**

READ THIS MANUAL CAREFULLY TO DIAGNOSE TROUBLE  
CORRECTLY BEFORE OFFERING SERVICE.

**MODEL : WD(M)-14400(5)TD / WD(M)-14401(6)TD  
WD(M)-12400(5)TD / WD(M)-12401(6)TD**

1. SPECIFICATION .....	3
2. FEATURES & TECHNICAL EXPLANATION .....	4
3. PARTS IDENTIFICATION .....	6
4. INSTALLATION.....	7
5. OPERATION .....	10
6. WIRING DIAGRAM /PROGRAM CHART .....	12
7. TROUBLESHOOTING.....	13
7-1. BEFORE PERFORMING SERVICE .....	13
7-2. QC TEST MODE.....	13
7-3. HOW TO KNOW THE WATER LEVEL FREQUENCY .....	13
7-4. ERROR DISPLAY .....	14
8. ERROR DIAGNOSIS AND CHECK LIST .....	16
8-1. DIAGNOSIS AND ANSWER FOR ABNORMAL OPERATION.....	16
8-2. FAULT DIAGNOSIS AND TROUBLESHOOTING .....	19
9. DISASSEMBLY INSTRUCTIONS.....	25
10. EXPLODED VIEW AND PARTS LIST.....	32
10-1. THE EXPLODED VIEW OF CABINET ASSEMBLY .....	32
10-2. THE EXPLODED VIEW OF CONTROL PANEL AND DISPENSER ASSEMBLY .....	33
10-3. THE EXPLODED VIEW OF DRUM AND TUB ASSEMBLY .....	34
※ APPENDIX (Replacement parts list) .....	35

# 1. SPECIFICATION

ITEM	WD(M)-14400(5)TD / WD(M)-14401(6)TD WD(M)-12400(5)TD / WD(M)-12401(6)TD	
POWER SUPPLY	220-240V~, 50Hz	
PRODUCT WEIGHT	58kg	
ELECTRICITY CONSUMPTION	WASHING	230W
	SPIN	440W
	DRAIN MOTOR	38W
	WASH HEATER	2000W
REVOLUTION SPEED	WASH	45rpm
	SPIN	1400 rpm :400/800/1000/1400 rpm
		1200 rpm :400/800/1000/1200 rpm
OPERATION WATER PRESSURE	0.3 - 10kgf/cm <sup>2</sup> (30 - 1000kPa)	
CONTROL TYPE	Electronic	
WASH CAPACITY	Cotton & Cotton-Eco (Rating)	
	Synthetic (3.5kg), Wool/Silk (2kg), Hand Wash (2kg), Delicate (3kg), Quick 30(5kg), Baby Care(6kg), Duvet(9Tog)	
DIMENSION	600mm(W)X550mm(D)X850mm(H)	
WASH PROGRAM	Cotton, Synthetic, Wool/Silk, Hand Wash, Delicate, Quick 30, Baby Care, Duvet	
RINSE	Rinse+ , Medic Care Rinse, Normal, Rinse Hold	
DOOR SWITCH TYPE	Bi-Metal type	
WATER LEVEL	9 steps (by sensor)	
RESERVATION	From 3 hours to 19 hours	
SENSING OF THE LAUNDRY AMOUNT	Adapted	
FUZZY LOGIC	Adapted	
DISPLAY OF THE REMAINING TIME	Adapted	
ERROR DIAGNOSIS	11 items	
POWER AUTO OFF	Adapted	
CHILD LOCK	Adapted	
AUTO RESTART	Non	
RAPID	Adapted	

## 2. FEATURES & TECHNICAL EXPLANATION

### 2-1. FEATURES

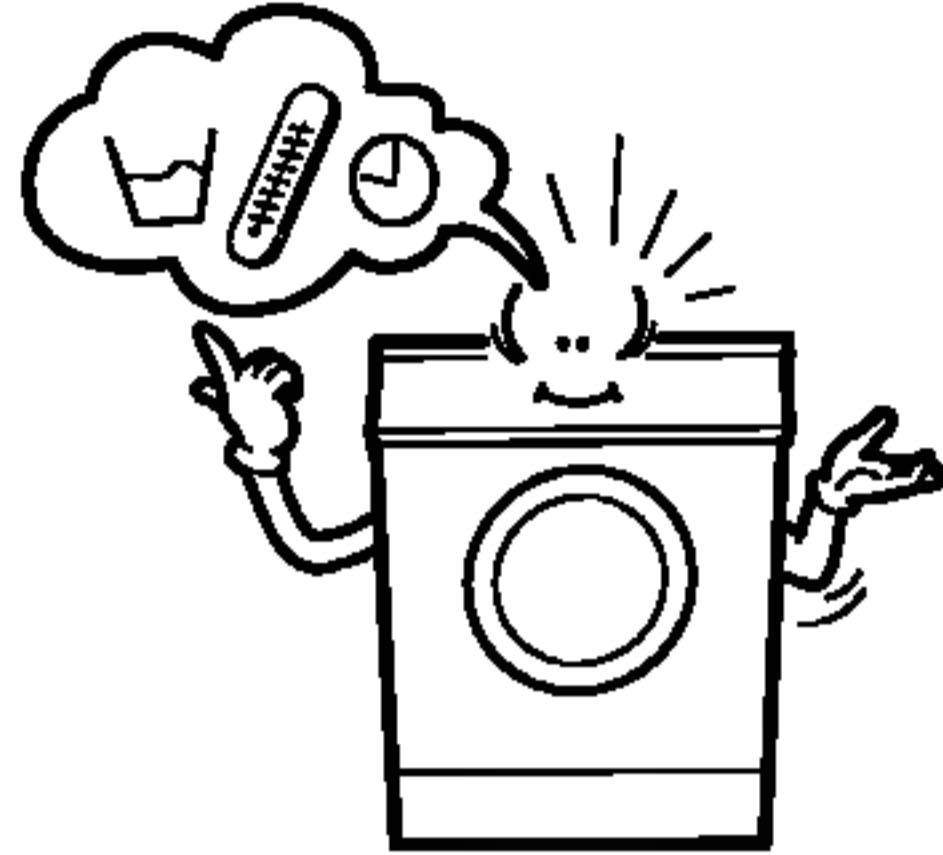

#### ■ **More economical by Intelligent Wash System**

Intelligent Wash System detects the amount of load and water temperature, and then determines the optimum water level and washing time to minimize energy and water consumption.

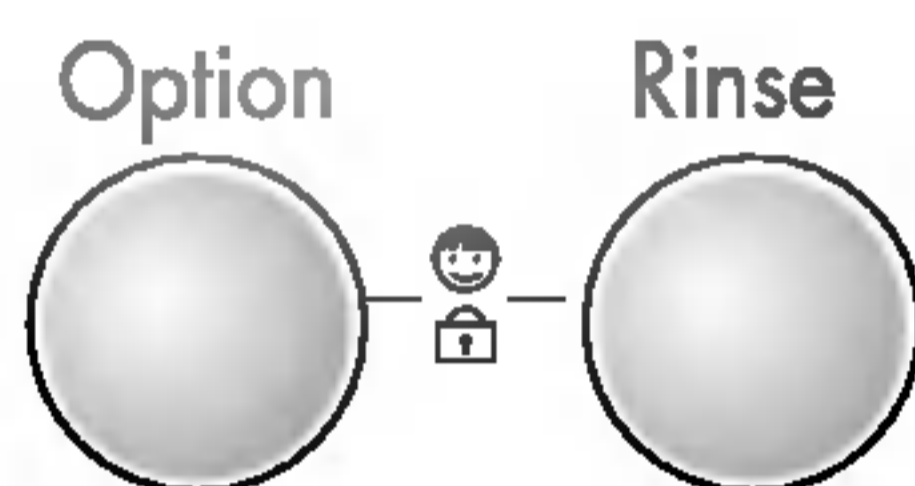

#### ■ **Child-Lock**

The Child-Lock system has been developed to prevent children from pressing any button to change the program during operation.

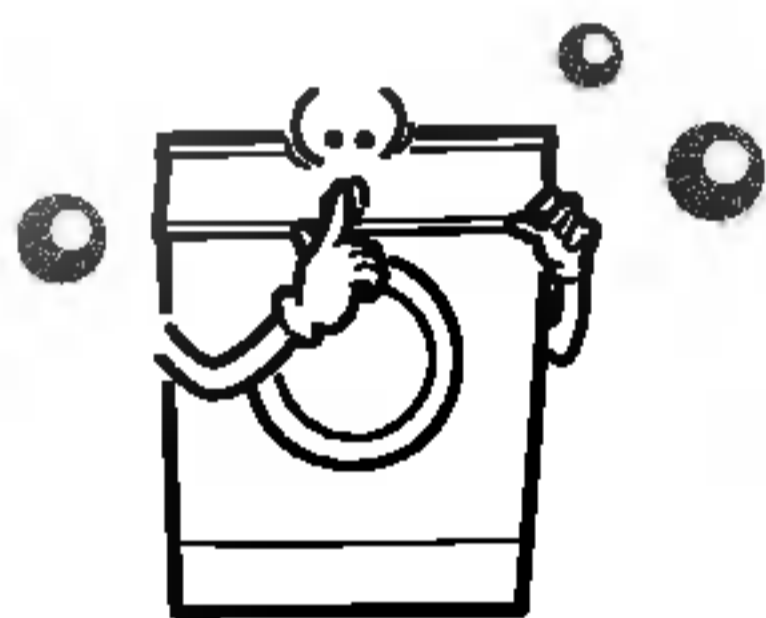

#### ■ **Low noise speed control system**

By sensing the amount of load and balance, automatical distributes load evenly to minimize the spinning noise level.



#### ■ **Safety device (Aqua lock)**

**WD(M)-14400(5)TD/12400(5)TD**

Aqua lock System is designed for detecting water leak during operation to prevent water from flooding over the floor.

## 2-2.DETERMINE WASHING TIME BY FUZZY LOGIC

To get the best washing performance optimal time is determined by sensing of water temperature, selected washing temperature and laundry amount.

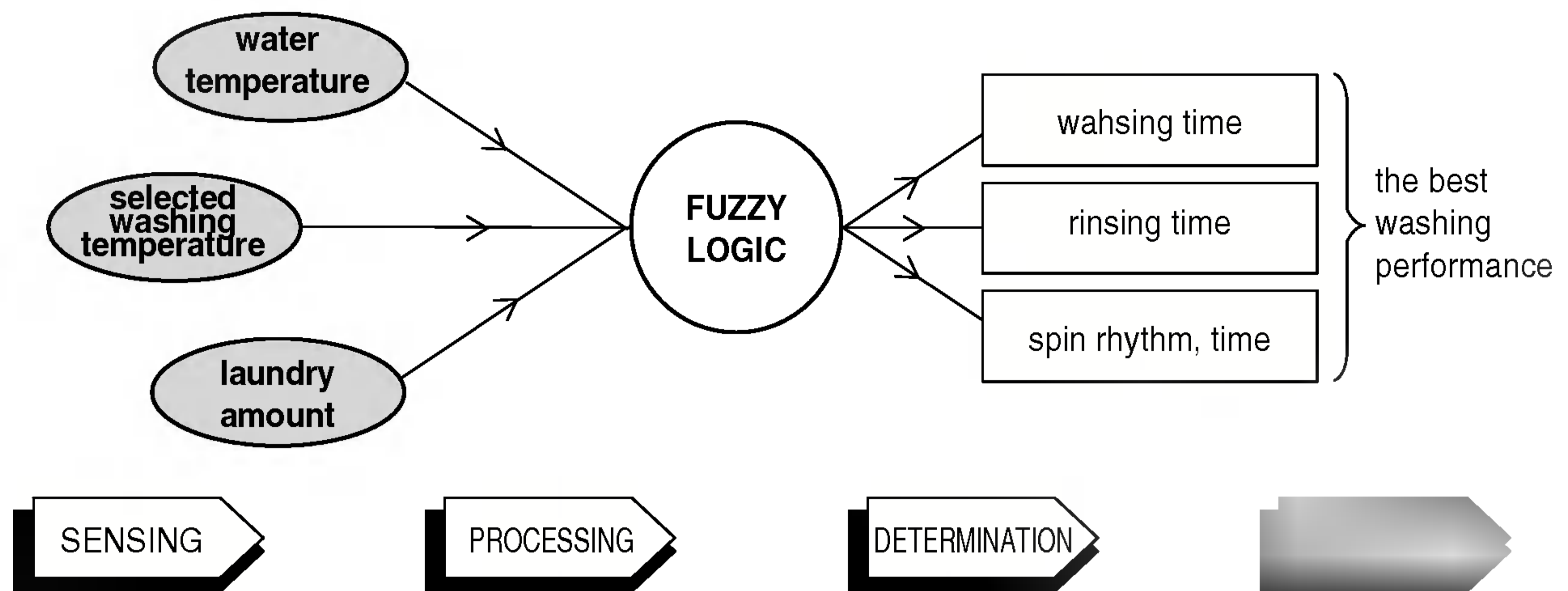

## 2-3.WATER LEVEL CONTROL

- This model adopts a pressure sensor which can sense the water level in the tub.
- Water supply is stopped when the water level to the preset level, then the washing program proceeds.

## 2-4.THE DOOR CAN NOT BE OPENED

- While program is operating.

# 3. PARTS IDENTIFICATION

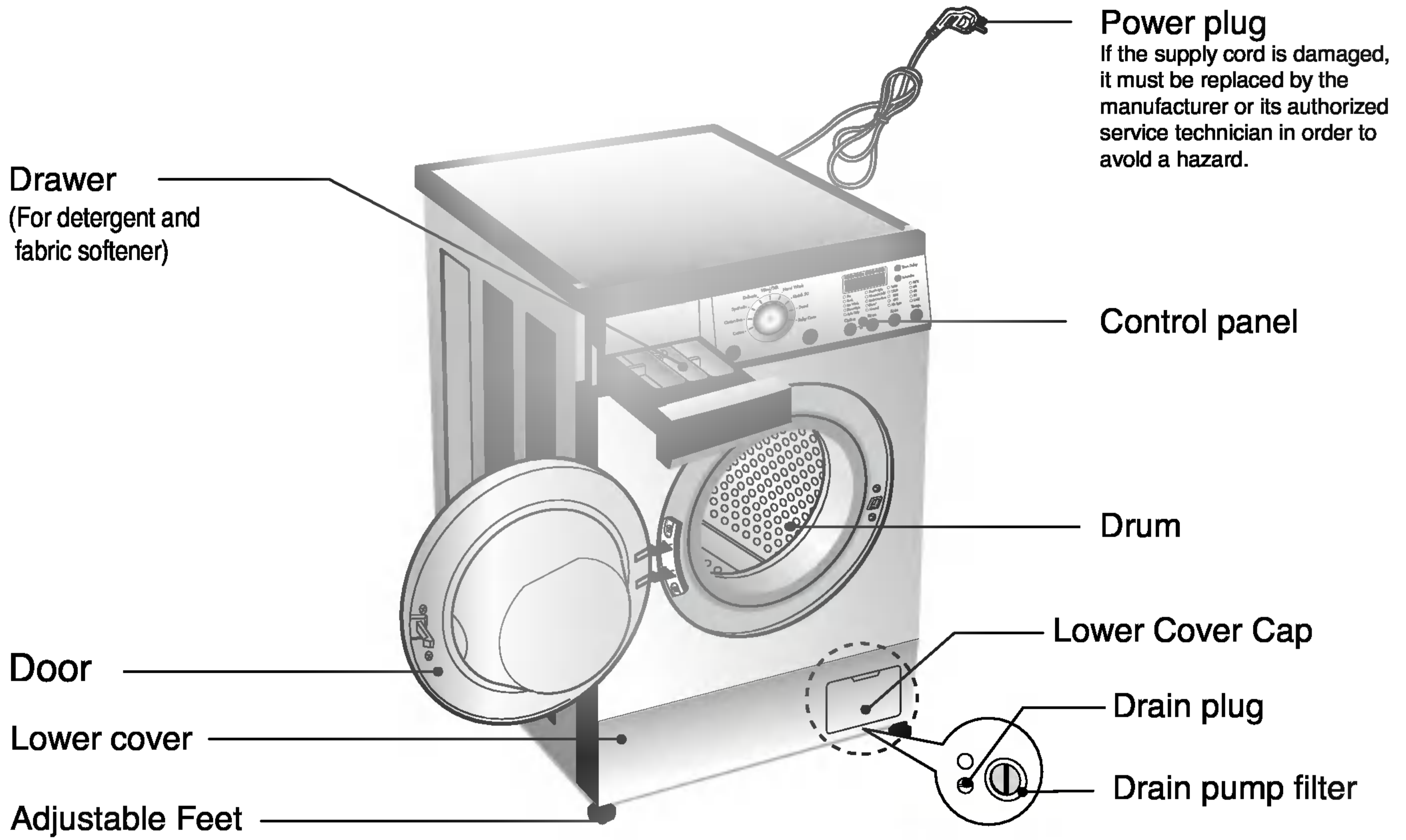

## ■ ACCESSORIES

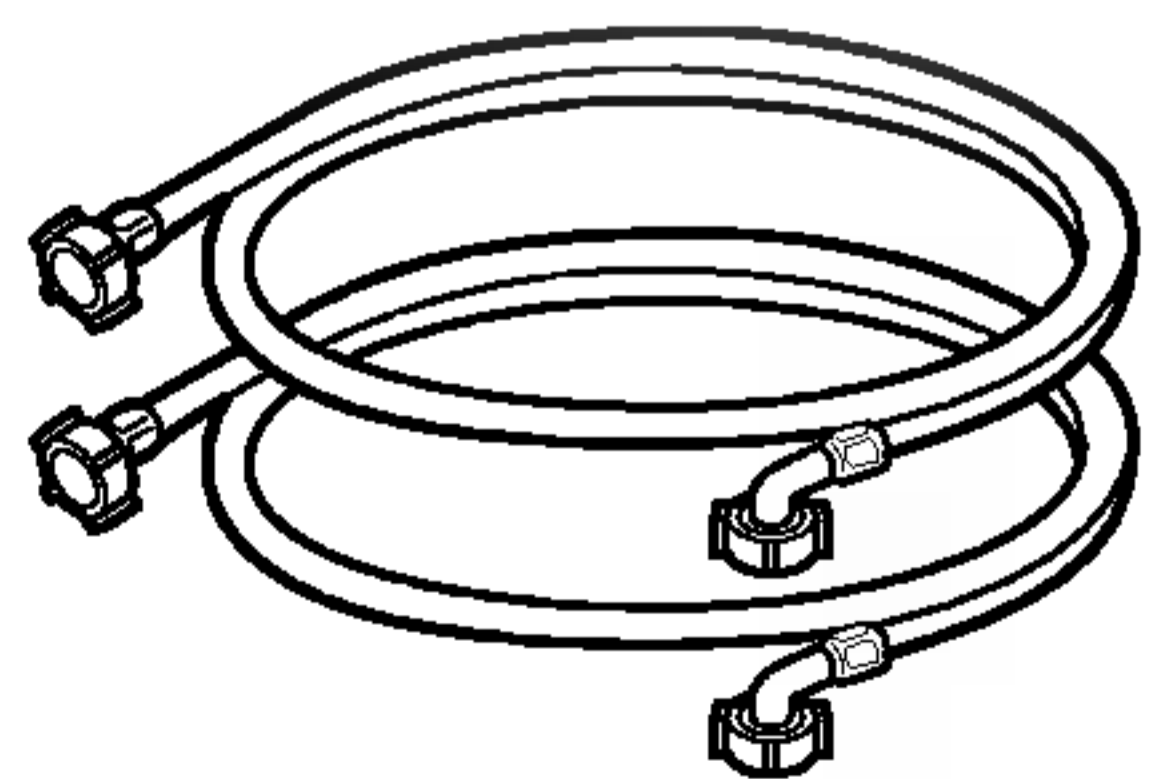

**Inlet Hose(1EA)**  
Option : Hot/Cold(2EA)

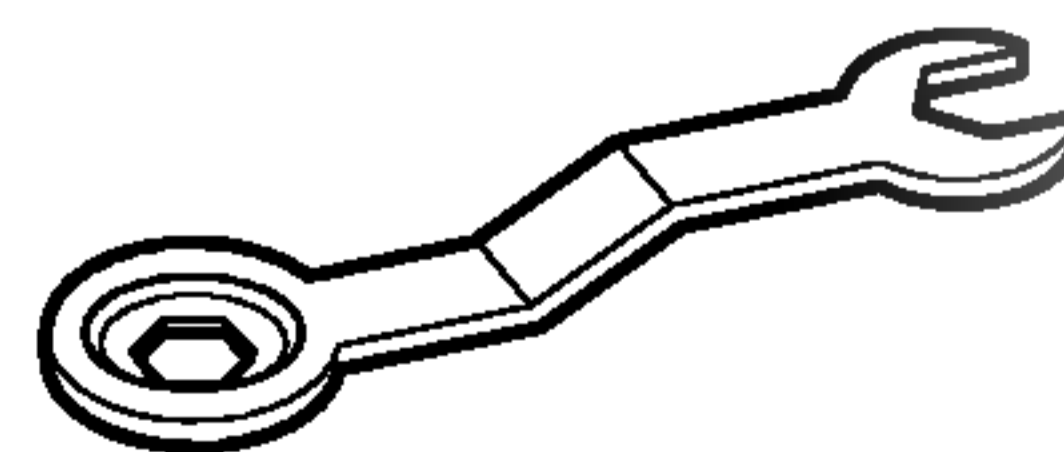

**Wrench**

# 4. INSTALLATION

- 1 Before servicing ask the customer what the trouble is.
- 2 Check the adjustment (power supply is 220-240V~,remove the transit bolts....)
- 3 Check the troubles referring to the troubleshooting.
- 4 Decide service steps referring to disassembly instructions.
- 5 Then,service and repair.
- 6 After servicing,operate the appliance to see whether it works O Kor NOT.

## ■ STANDARD INSTALLATION

The appliance should be installed as follows.

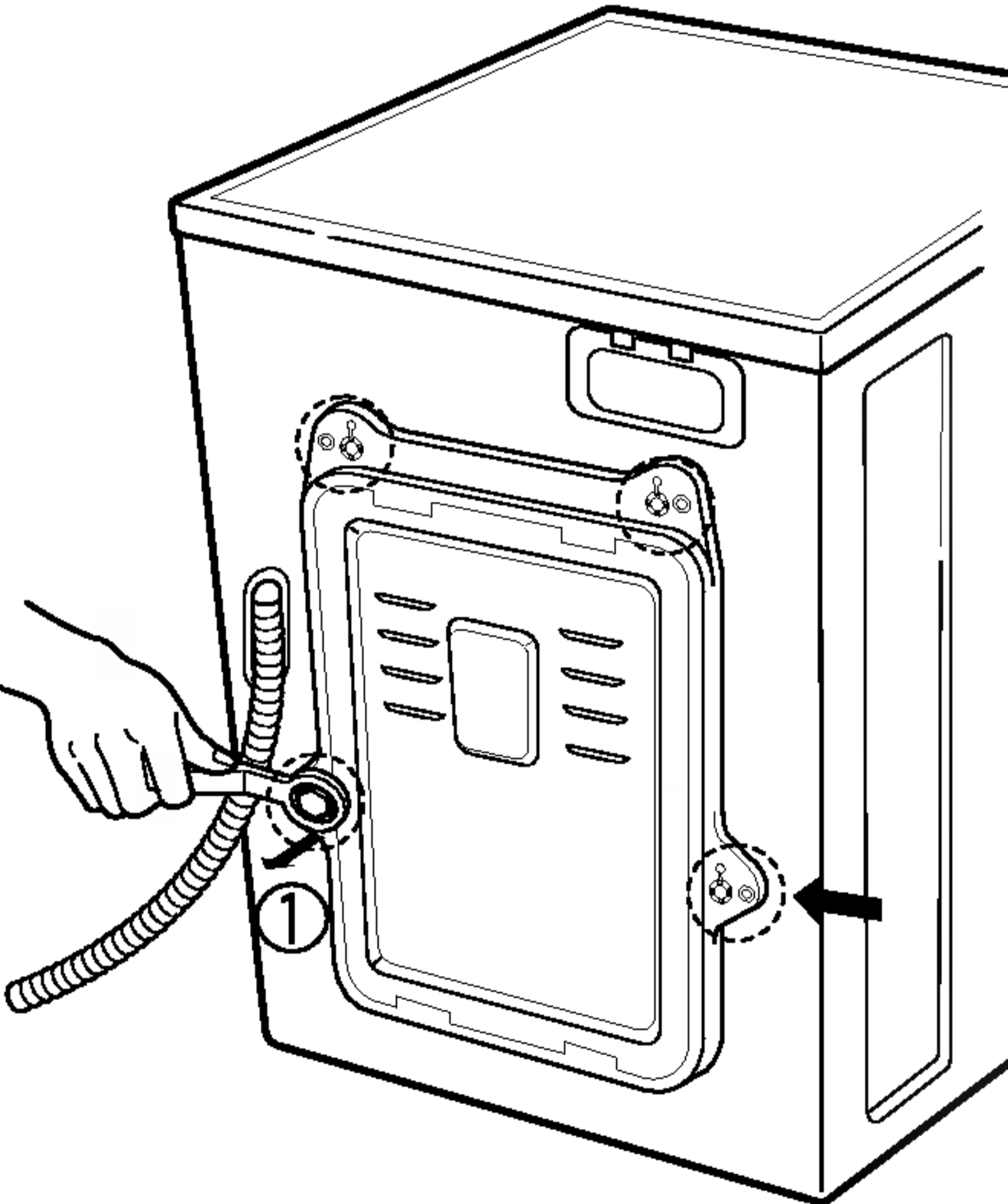
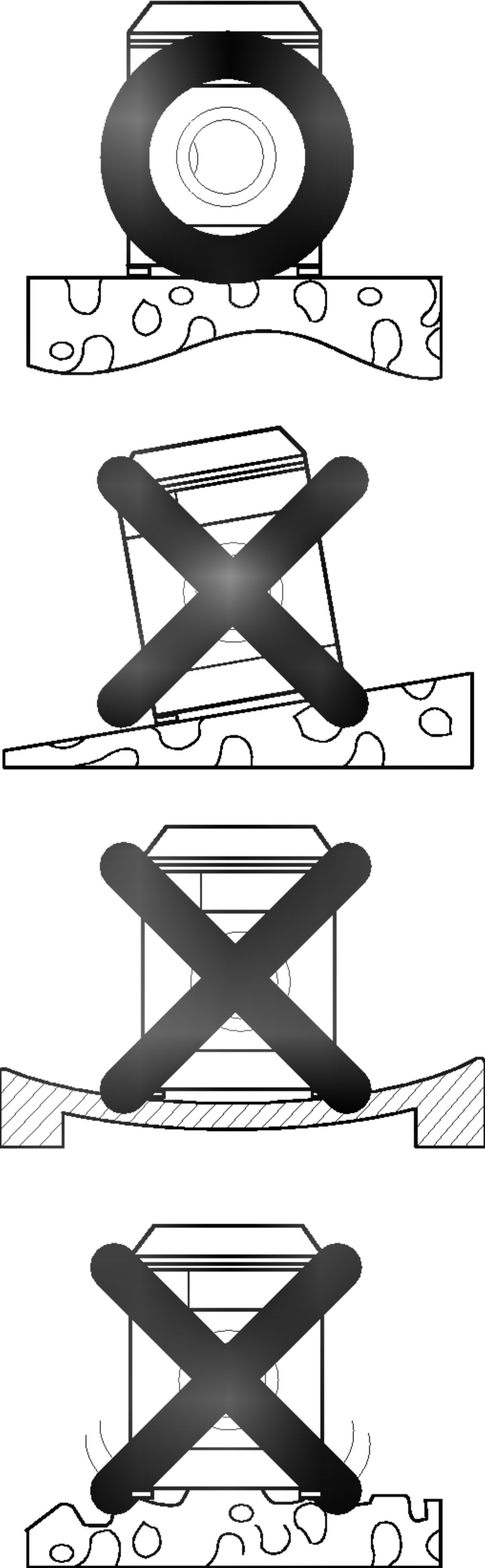
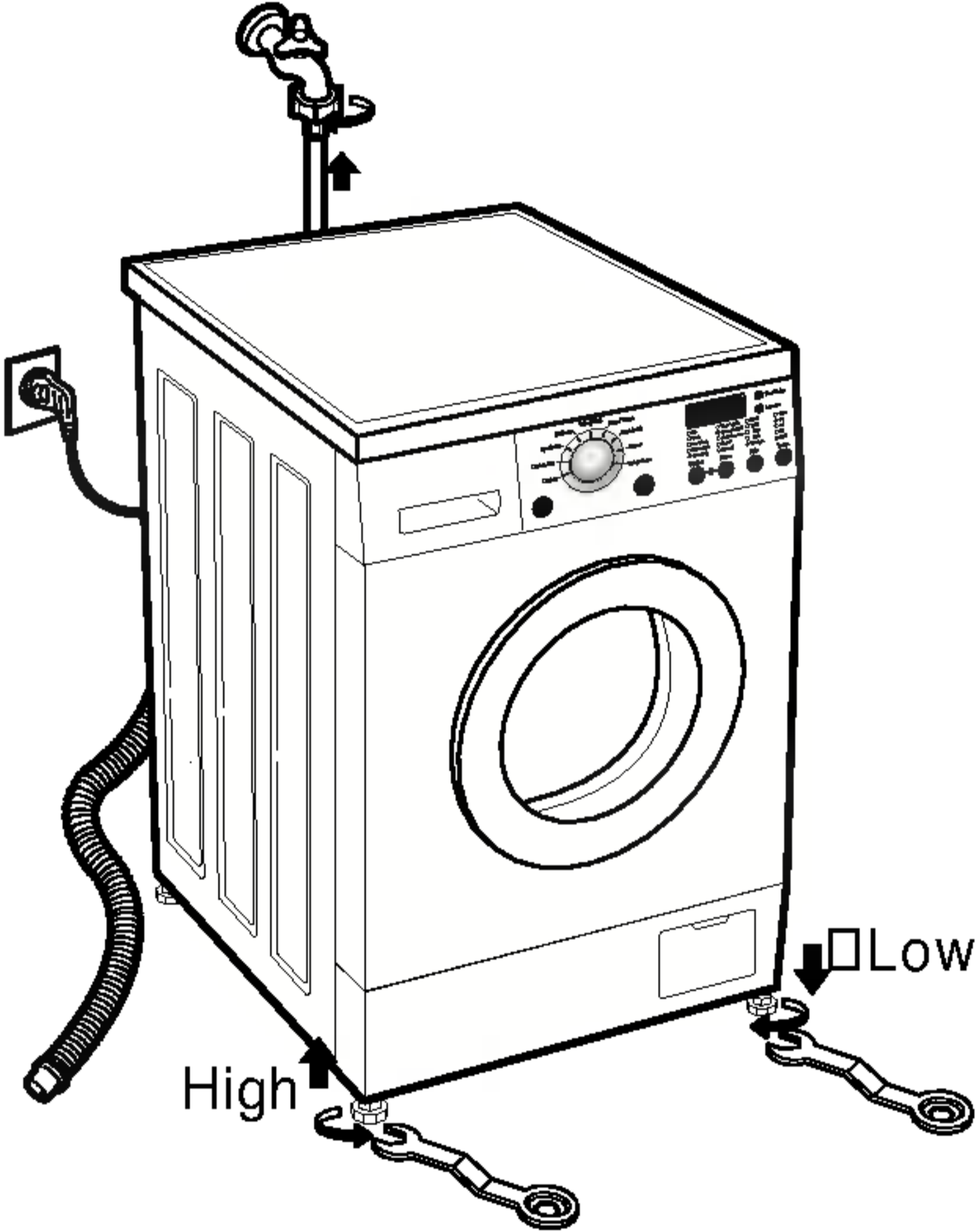
REMOVE THE TRANSIT BOLTS	INSTALL THE APPLIANCE ON FLAT AND FIRM SURFACE	ADJUST THE HORIZONTAL
<ul style="list-style-type: none"> <li>• Remove the transit bolts (4EA:①) with supplied spanner.Keep the transit bolts and</li> <li>• spanner for future use.</li> <li>• Insert the provided 4 caps</li> <li>• into the hole</li> </ul> 		<ul style="list-style-type: none"> <li>• Turn the leveling feet to set the appliance horizontally.</li> </ul>  <ul style="list-style-type: none"> <li>• The appliance goes up by rotating the feet clockwise.</li> <li>• The appliance comes down by rotating the feet counter-clockwise.</li> </ul>

## ■ HOW TO CONNECT INLET HOSE

- Check that the rubber washer is inside of the valve connector.
- Connect the inlet hose firmly to prevent leak.

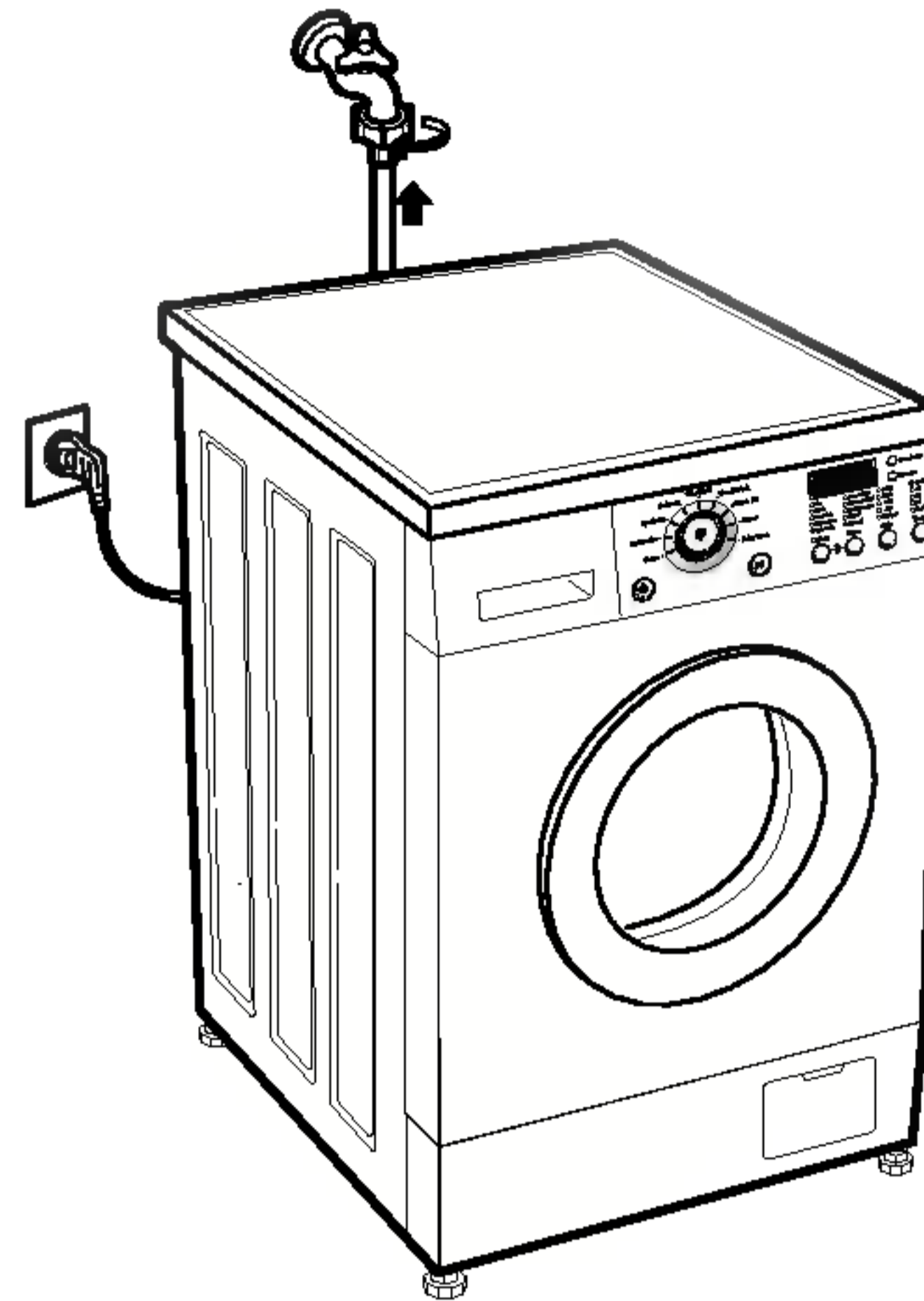

## ■ CONNECT DRAIN HOSE

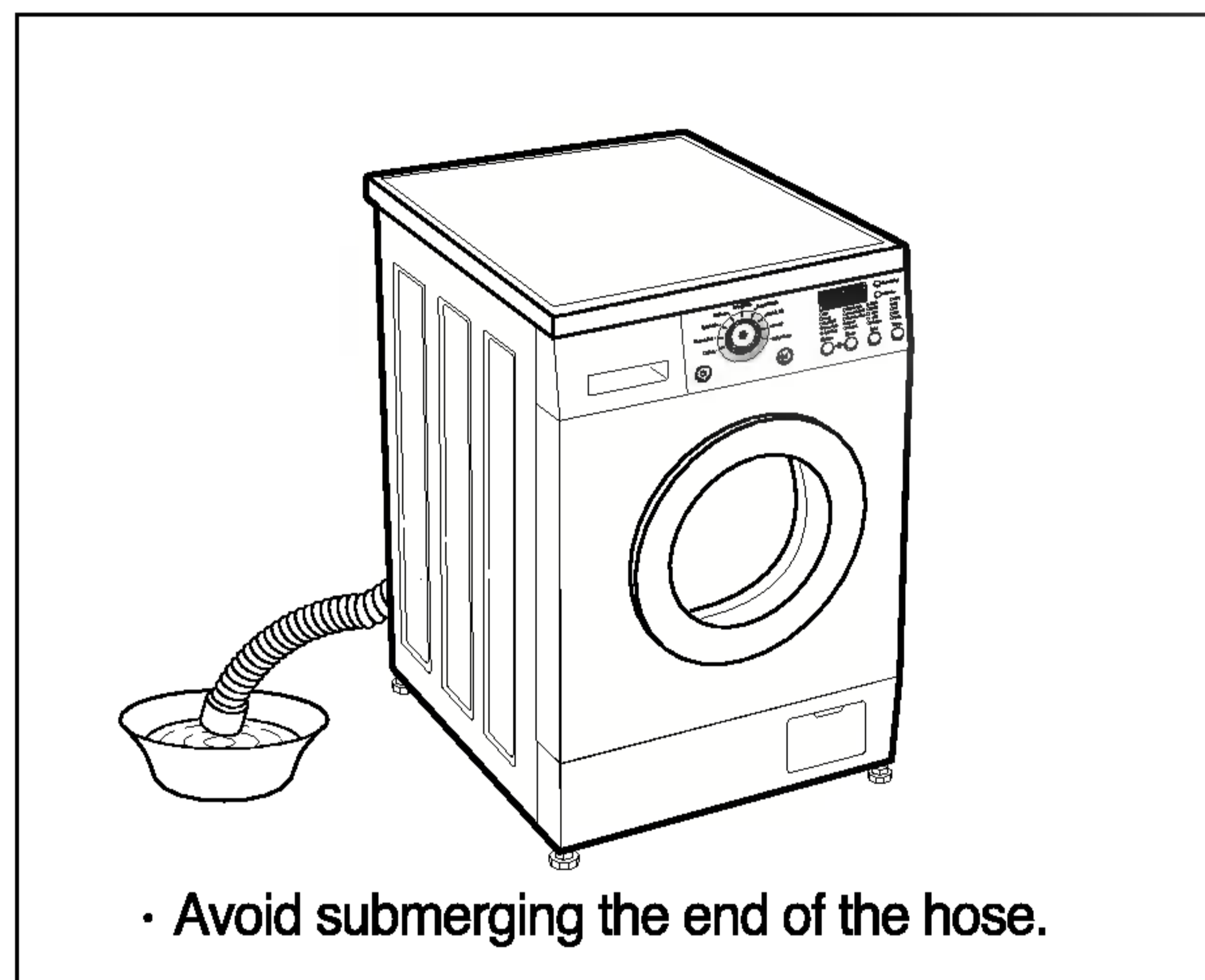
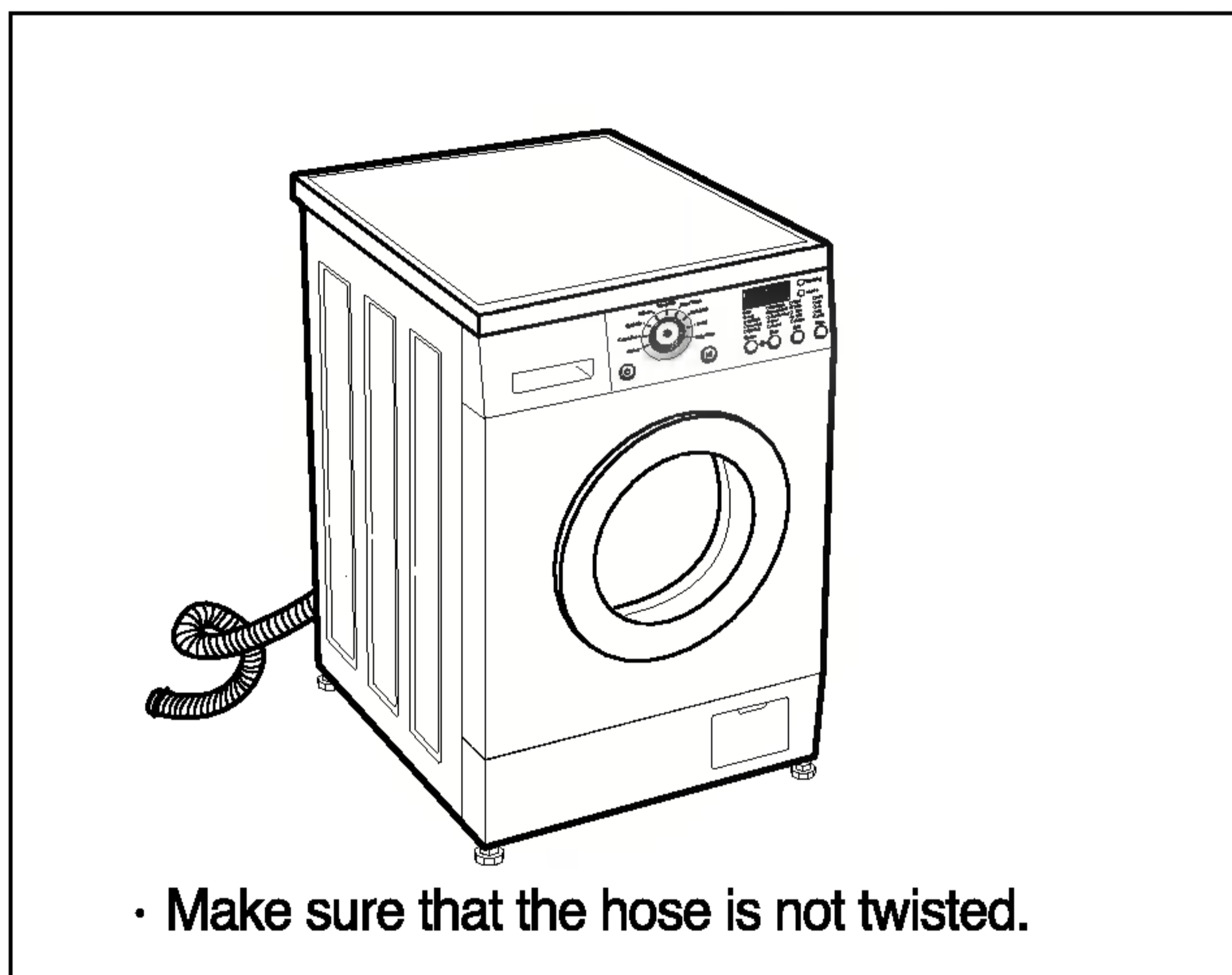

※ The drain hose should be placed under 100cm from the floor.

## ■ CONNECT POWER PLUG

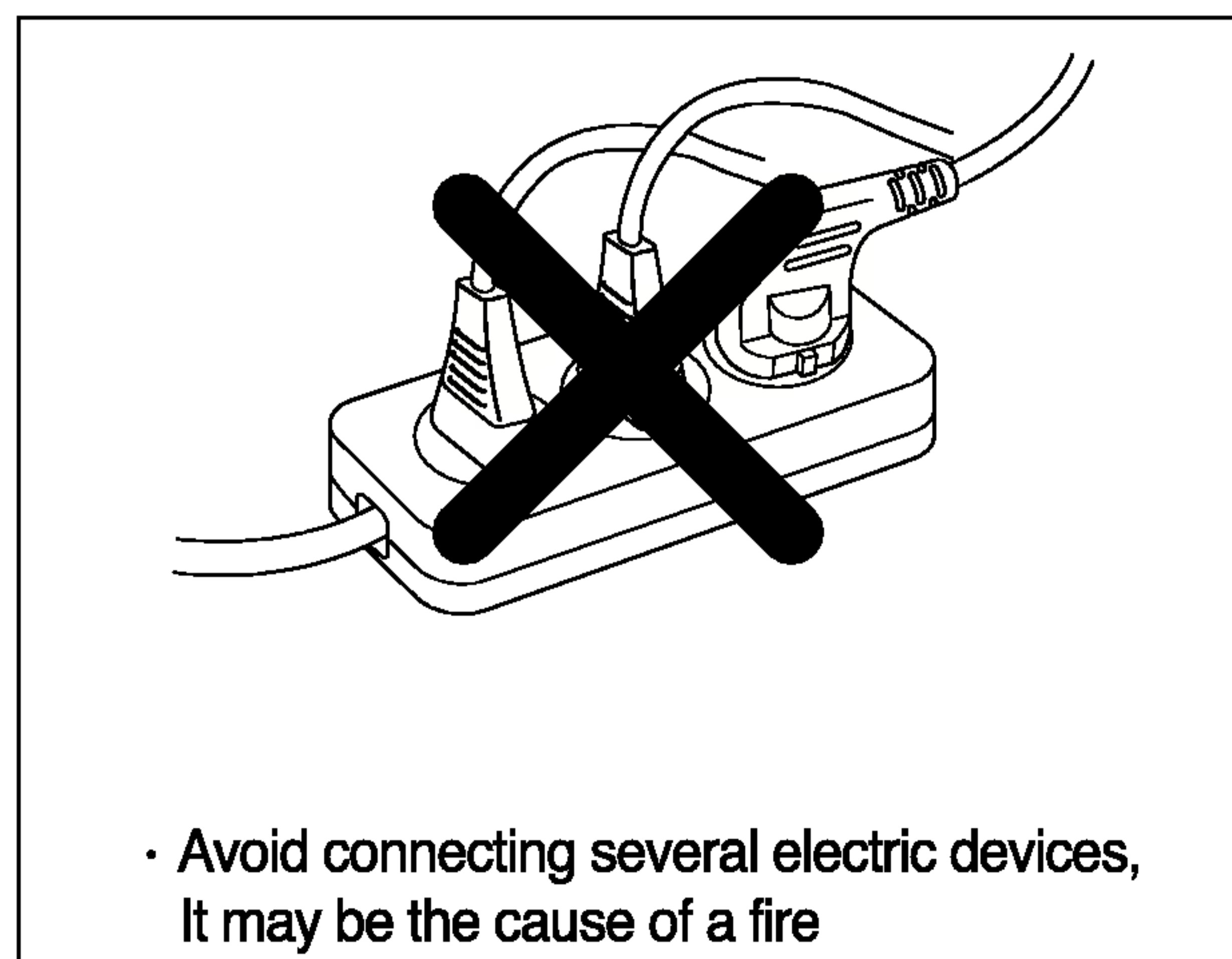
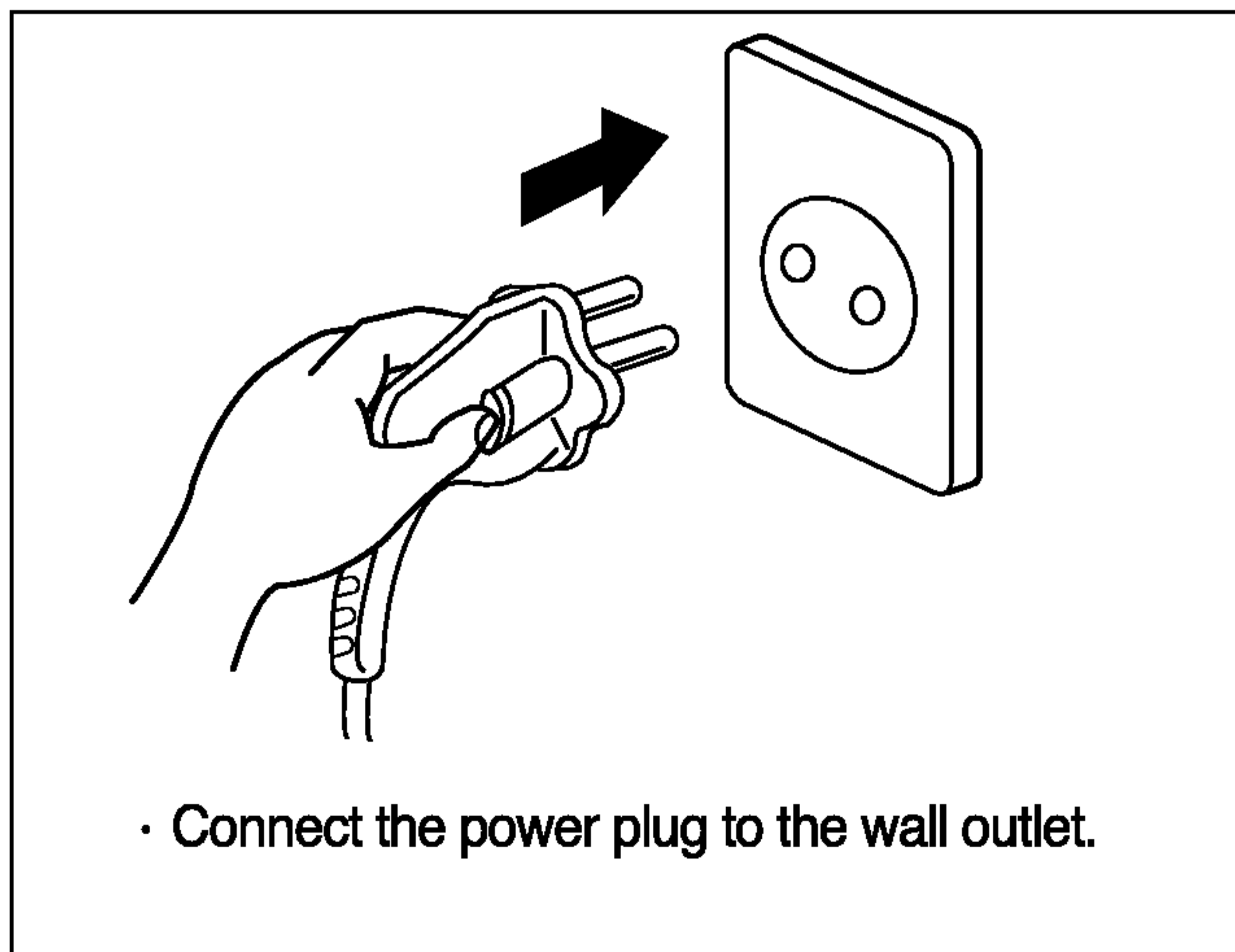



## 7 TEST OPERATION

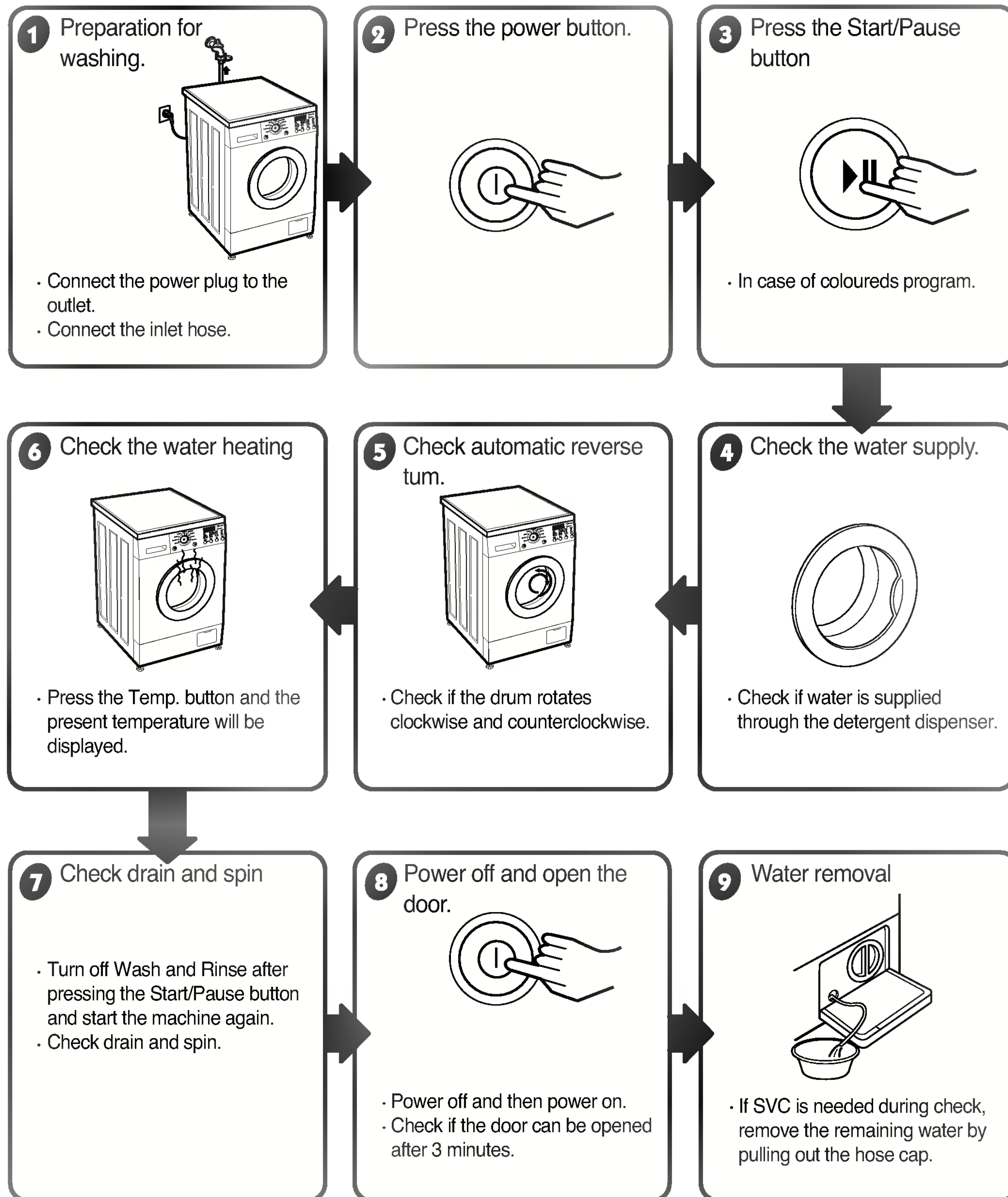

## Wash program selector

- 9 program can be set depending on the type of the laundry.
- If the power button is pressed, Cotton program is automatically set.
- By turning the dial, [Cotton, Cotton-Eco, Synthetic, Delicate, Wool/Silk, Hand Wash, Quick 30, Duvet, Baby Care] can be selected.  
(The opposite is possible)

## LED display

- Display the estimated remaining time (Hour : Minute) to finish.
- In case of abnormal operation, error indications are displayed.  
( IE OE UE JE LE FE PE CE LE REPF )
- See troubleshooting guide.

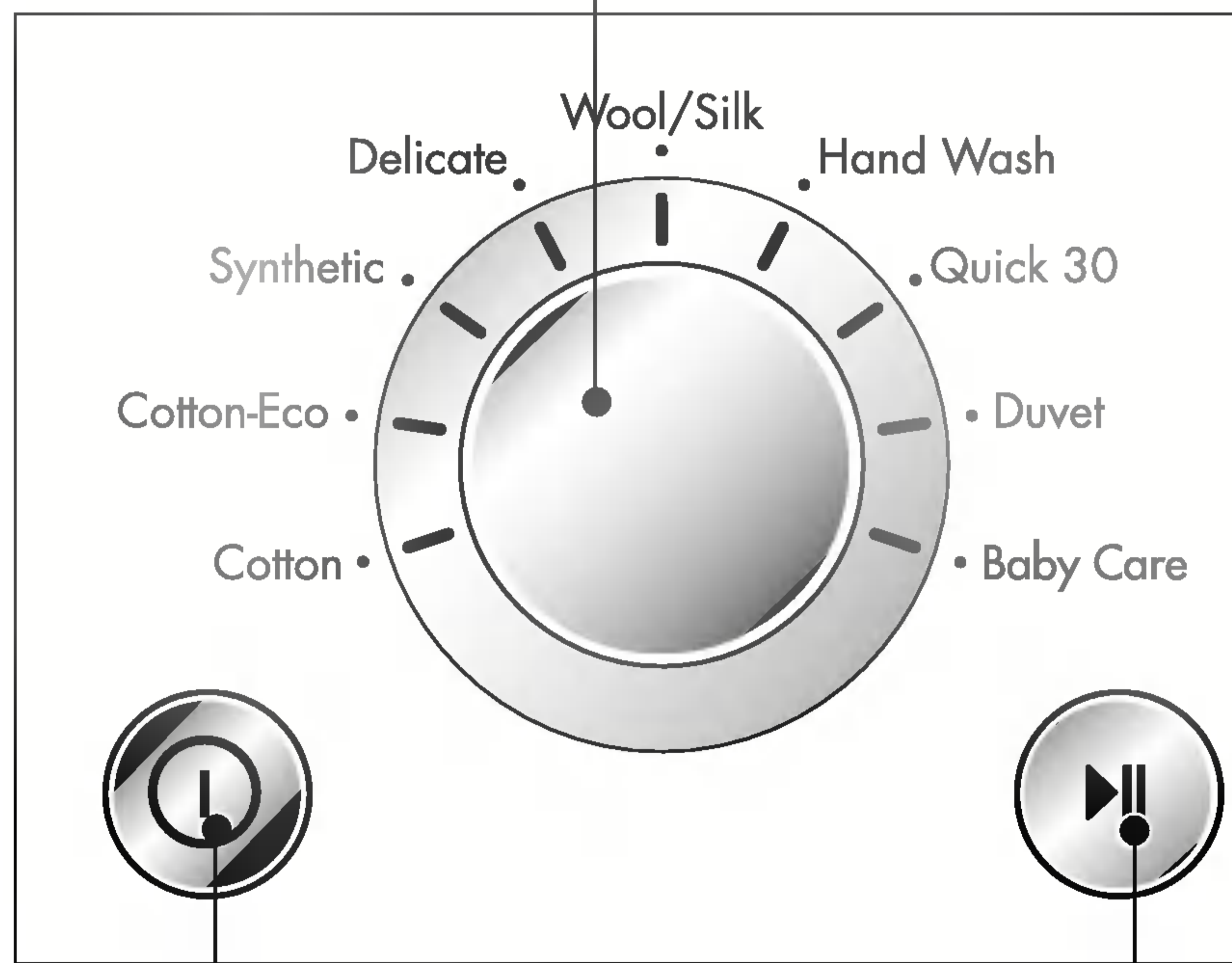

## POWER button

- Use this button to turn the power On/Off

## Start/Pause button

- Use the button to start or pause wash cycle.
- The power turns off automatically 4 minutes after the pause button is pressed.

## Time Delay

- Press the button when delayed washing is needed.
- When the button is pressed, **3:00** is displayed, maximum delay of **19:00** hours can be set.
- Each press advances time delay by the hour.
- Use [Power] button to cancel [Time Delay]
- [Time Delay] means the time required from the present to the completion of washing.

## STATUS INDICATOR

- These lights show which portion of the cycle the washer is operating.

## INTENSIVE

- If the laundry is heavily soiled "Intensive" option is effective.
- By selecting the Intensive option, the wash time may be extended, depending on the program selected.
- To use this option press the Intensive button once before the wash program is started.

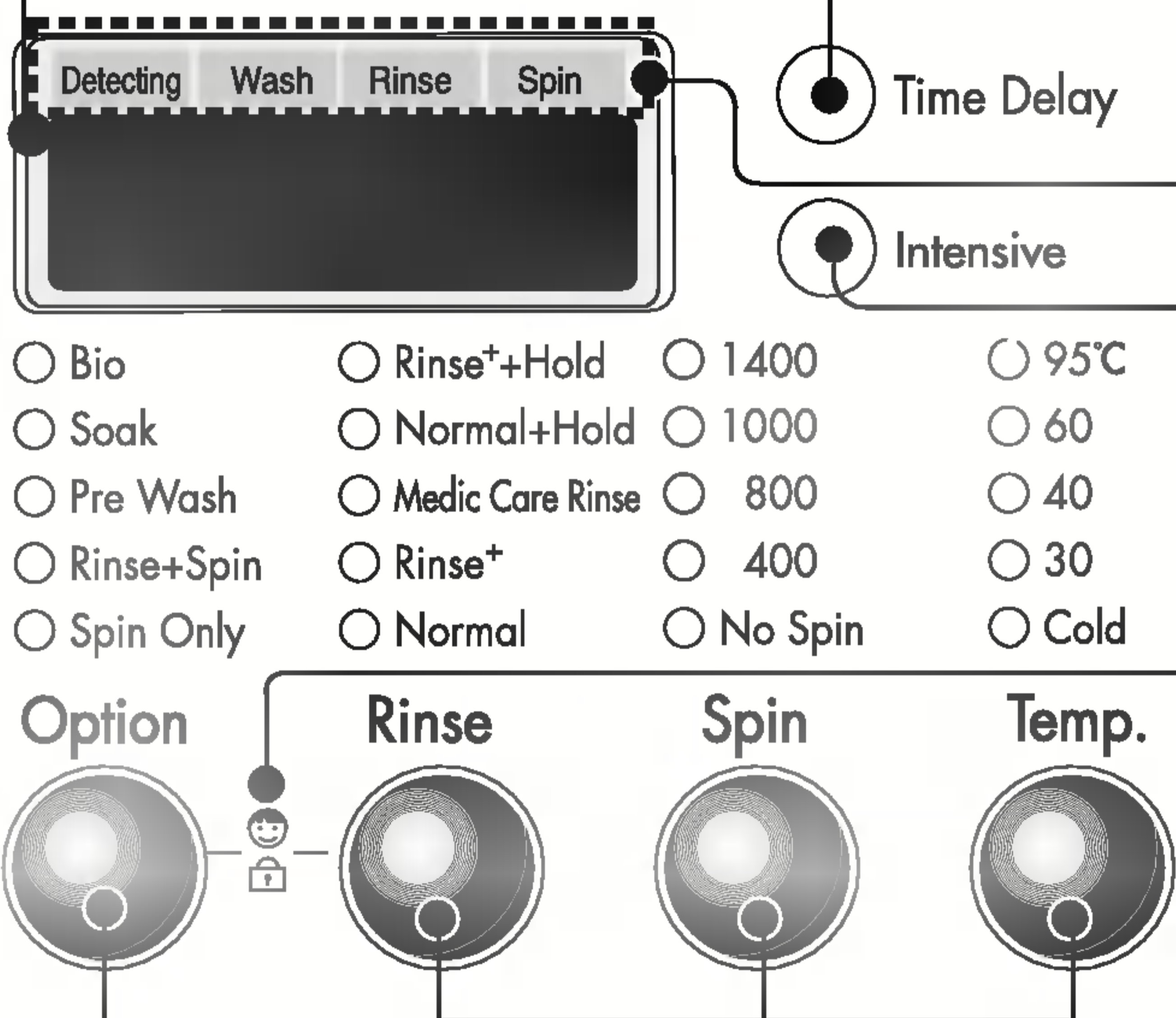

## Child - Lock

- **Child Lock** system can be set and canceled by pressing and holding both [Rinse] and [Option] button simultaneously more than 2 seconds.
- Once Child Lock is set, all buttons are inoperable except power button.
- **Child Lock** system can be set anytime even during
- Power-off and operation.
- It is automatically cancelled when an operational error occur.

## OPTION button

- Pre Wash: Use this option for loads that need pretreatment. It add 16 minutes pre wash and drain.
- Rinse+Spin: Use this option to rinse and then spin.
- Soak: Use this mode to wash normal clothes or thick and heavy clothes which are excessively dirty.
- Spin Only: When you want Spin only, select this option.
- Bio: If you want to eliminate protein stains, you may select Bio function.

## Rinse, Spin, Temp., Button

- Select a water temperature based on the type of load you are washing.
- To change the spin speed, press the Spin Speed button repeatedly to cycle through available options.
- To change the soil level, press the Soil Level button repeatedly until the desired setting is on.

# 6. WIRING DIAGRAM / PROGRAM CHART

\* Water Supply : W·S    \* Intermittent Spin : I·S    \* Disentangle : D·T

CYCLE STEP COURSE	Washing										Rinse										Spin			E N D	A U T O F F	Normal Working Time (Hour:Minute)						
	Pre			Main							Normal				Rinse +						Drain	Spin	D·T									
	W·S	Washing	Drain	W·S	Heating	Washing	Staycooling		W·S	Rinsing	Drain	Drain	I·S	W·S	Rinsing	Drain	I·S	W·S	Rinsing	Drain							I·S	W·S	Rinsing			
							1	2													3	4	5							6	7	8
Time (SEC)	120	MIN	60	240	120	MIN						60	240	120	360	60	240	120	360	60	240	120	360	60	240	120	360	60	480	120	20	20
Cotton	-----			-----							-----				-----						-----			-----		About 1:40						
Baby Care	-----			-----							-----				-----						-----			-----		About 2:20						
Synthetic	-----			-----							-----				-----						-----			-----		About 1:30						
Delicate	-----			-----							-----				-----						-----			-----		About 1:00						
Wool/Silk	-----			-----							-----				-----						-----			-----		About 1:00						
Handwash	-----			-----							-----				-----						-----			-----		About 1:00						
Duvet	-----			-----							-----				-----						-----			-----		About 1:10						
Quick	-----			-----							-----				-----						-----			-----		About 30						
Rinsing + Spin	-----			-----							-----				-----						-----			-----		About 21						
Drain	-----			-----							-----				-----						-----			-----		About 1						

\* Basic Cycle

\* Optional Cycle

\* Pre-Setting Time : Water Supply - 120 sec.

Drain - 60 sec.

\* ~ Time for varies as the temperature or the amount of laundry

\* Basic time is minute in washing chart

\* The actual program time can be varied with the load amount, water temperature or ambient temperature

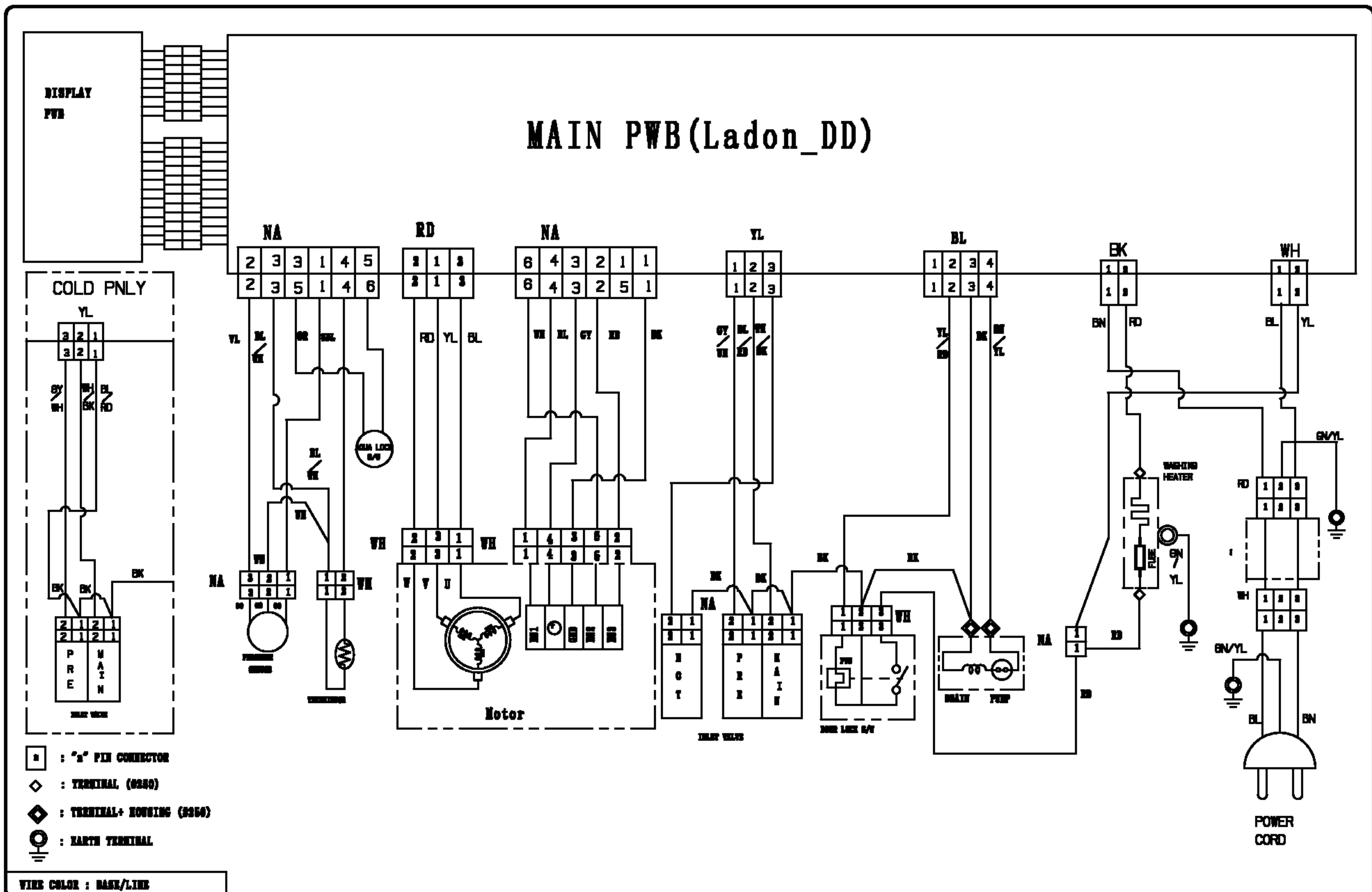

# 7. TROUBLESHOOTING

## 7-1. BEFORE PERFORMING SERVICE

- Be careful of electric shock or disconnecting the parts while troubleshooting.
- Voltage of each terminal in 220-240V~and DC while applying an electric current.

## 7-2. QC TEST MODE.

- ① Pressing Option, and Spin button simultaneously.
- ② Power supply on with pressing upper two button. Then buzzer sound twice.
- ③ Press the Start/Pause button as follows.  
[ Press the Start/Pause button more 4 times until stop spinning ]

Pressing number of [Start/Pause] button	Checking Point	Display Status
None	All lamps turn on	
1 time	Clockwise spin (right)	Drum rpm (About 40~50)
2 times	Low speed Spin	Drum rpm (About 53~65)
3 times	High speed Spin	Drum rpm (About 120~140)
4 times	Inlet valve for prewash operation	Water level frequency (25~65)
5 times	Inlet valve for mainwash operation	Water level frequency (25~65)
	Hot inlet valve in case of hot water fill	
6 times	Inlet valve for mainwash operation	Water level frequency (25~65)
7 times	Counterclockwise spin (left)	Drum rpm (About 40~50)
8 times	Heater is in operation for 3 sec.	Water temperature
9 times	Circulation pump operation	Water level frequency
10 times	Draining pump operation	Water level frequency
11 times	Auto off operation	

## 7-3. HOW TO KNOW THE WATER LEVEL FREQUENCY

\* Press the **Rinse** and **Spin** button simultaneously.

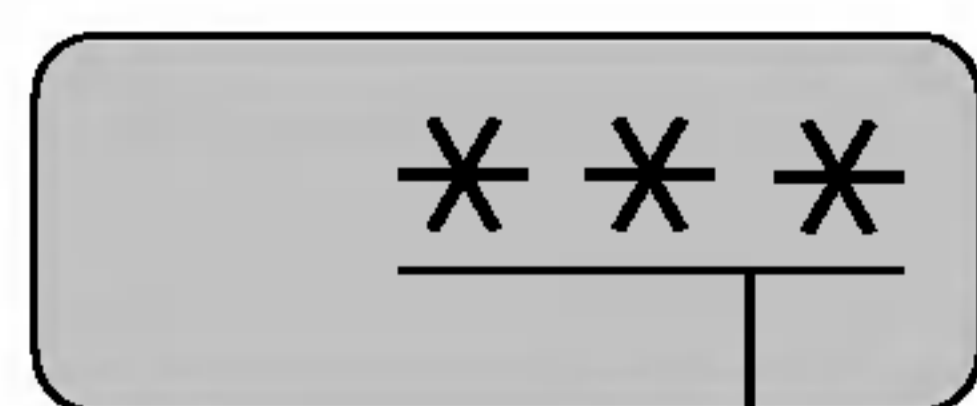











The digits means water level frequency ( $10^{-1}$  kHz)

ex)241 : Water level frequency =  $241 \times 10^{-1}$  kHz = 24.1 kHz

## 7-4. ERROR DISPLAY





- If you press the Start/Pause button when an error is displayed, any error except **PE** will disappear and the machine will change into pause status.
- In case of **PE**, **LE**, **DE** if the error is not resolved within 20 sec. In the case of other errors, if the error is not resolved within 4 min., power will be turned off automatically and the error only will be blinked. But in the case of **FE**, power will not be turned off.

	ERROR	SYMPTOM	CAUSE
1	WATER INLET ERROR		<ul style="list-style-type: none"> <li>○ Water has not reached to the pre-set level within 8 min. since inlet valve operated, or water has not reached to the normal level within 25 min.</li> </ul>
2	IMBALANCE ERROR		<ul style="list-style-type: none"> <li>○ Load is too small.</li> <li>○ The appliance is tilted.</li> <li>○ Laundry is gathered to one side.</li> <li>○ Non-distributable things are put into the drum.</li> </ul>
3	DRAIN ERROR		<ul style="list-style-type: none"> <li>○ Water has not drained enough within 10 min.</li> </ul>
4	OVERFLOW ERROR		<ul style="list-style-type: none"> <li>○ Water is automatically being pumped out because too much water is in the tub.</li> </ul>
5	SENSOR PRESSURE SW ERROR		<ul style="list-style-type: none"> <li>○ The sensor pressure switch is out of order.</li> </ul>
6	DOOR OPEN ERROR		<ul style="list-style-type: none"> <li>○ The Start/Pause button is pressed with the door open.</li> <li>○ The door switch is out of order.</li> </ul>
7	HEATING ERROR		<ul style="list-style-type: none"> <li>○ The THERMISTOR is out of order.</li> </ul>

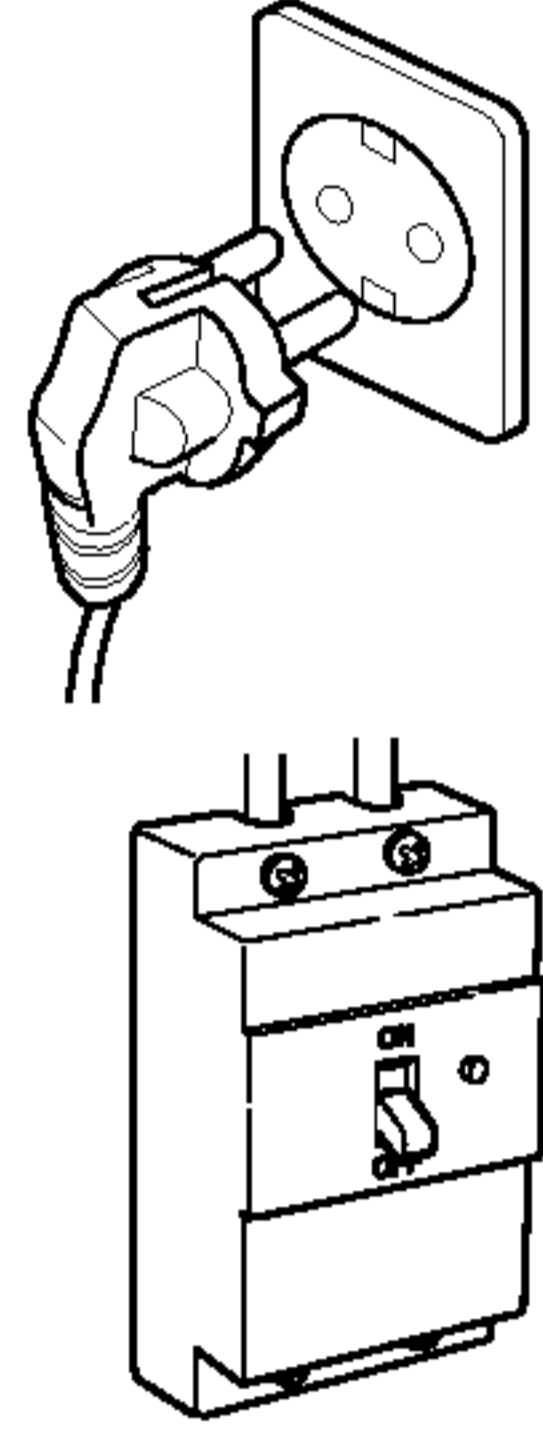

	ERROR	SYMPTOM	CAUSE
8	CURRENT ERROR		<ul style="list-style-type: none"> <li>○ MAIN PWB ASSEMBLY is out of order <ul style="list-style-type: none"> <li>☞ Replace the MAIN PWB ASSEMBLY</li> </ul> </li> <li>○ Winding in the STATOR ASSEMBLY is short-circuited. <ul style="list-style-type: none"> <li>☞ Replace the STATOR ASSEMBLY</li> </ul> </li> </ul>
9	LOCK ERROR		<ul style="list-style-type: none"> <li>○ The connector (3-pin, male, white) in the LEAD WIRE ASSEMBLY is not connected to the connector (3-pin, female, white) of STATOR ASSEMBLY. <ul style="list-style-type: none"> <li>☞ Reconnect or repair the connector</li> </ul> </li> <li>○ The electric contact between the connectors 3-pin, male, white in the LEAD WIRE ASSEMBLY and 4-pin, female, natural in the MAIN PWB ASSEMBLY is bad or unstable. <ul style="list-style-type: none"> <li>☞ Reconnect or repair the contact in the connector</li> </ul> </li> <li>○ The LEAD WIRE ASSEMBLY between the STATOR ASSEMBLY and MAIN PWB ASSEMBLY is cut (open circuited). <ul style="list-style-type: none"> <li>☞ Repair the damaged (open-circuited) the LEAD WIRE ASSEMBLY</li> </ul> </li> <li>○ The hall sensor is out of order / defective. <ul style="list-style-type: none"> <li>☞ Replace the STATOR ASSEMBLY</li> </ul> </li> </ul>
10	WATER LEAKS		<ul style="list-style-type: none"> <li>○ Water leaks [WD(M)-14400(5)TD/12400(5)TD]</li> </ul>
11	POWER FAILURE		<ul style="list-style-type: none"> <li>○ The washer experienced a power failure.</li> <li>○ Restart the cycle.</li> </ul>

# 8. ERROR DIAGNOSIS AND CHECK LIST

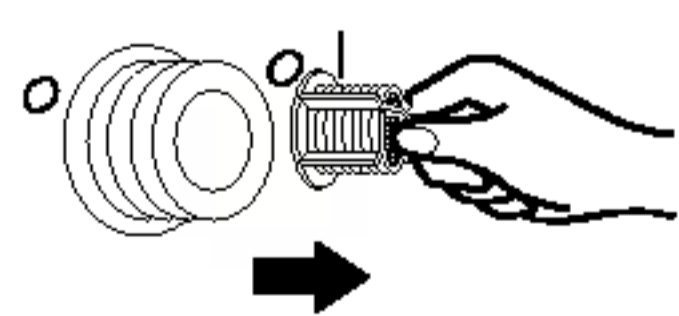
## 8-1. DIAGNOSIS AND ANSWER FOR ABNORMAL OPERATION

SYMPTOM	GUIDE FOR SERVICE CALL
<p>NO POWER</p>	<div style="display: flex; justify-content: space-between;"> <div style="width: 65%;"> <p>Is the power plug connected firmly to 220-240V ~ outlet?</p> <p style="text-align: center;"><b>YES</b></p> <p>Power failure? or Breaker opened? Is the outlet controlled by a switch</p> <p style="text-align: center;"><b>NO</b></p> <p style="text-align: center;">Visit to check</p> </div> <div style="width: 30%; text-align: center;">  </div> </div>
<p>WATER INLET TROUBLE</p> <div style="text-align: center; margin-top: 20px;">  </div>	<div style="display: flex; justify-content: space-between;"> <div style="width: 65%;"> <p>Is  displayed?</p> <p style="text-align: center;"><b>YES</b></p> <p>Is the tap opened?</p> <p style="text-align: center;"><b>YES</b></p> <p>Is the tap frozen?</p> <p style="text-align: center;"><b>NO</b></p> <p>Is the water supply shut-off?</p> <p style="text-align: center;"><b>NO</b></p> <p>Is filter in the inlet valve clogged with foreign material?</p> <p style="text-align: center;"><b>NO</b></p> <p style="text-align: center;">Visit to check</p> </div> <div style="width: 30%; text-align: center;">   <div style="border: 1px solid black; padding: 5px; margin-top: 10px; text-align: center;"> <p>Clean the filter of inlet valve</p>  </div> </div> </div>

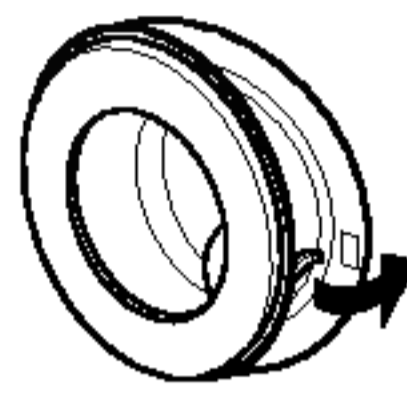

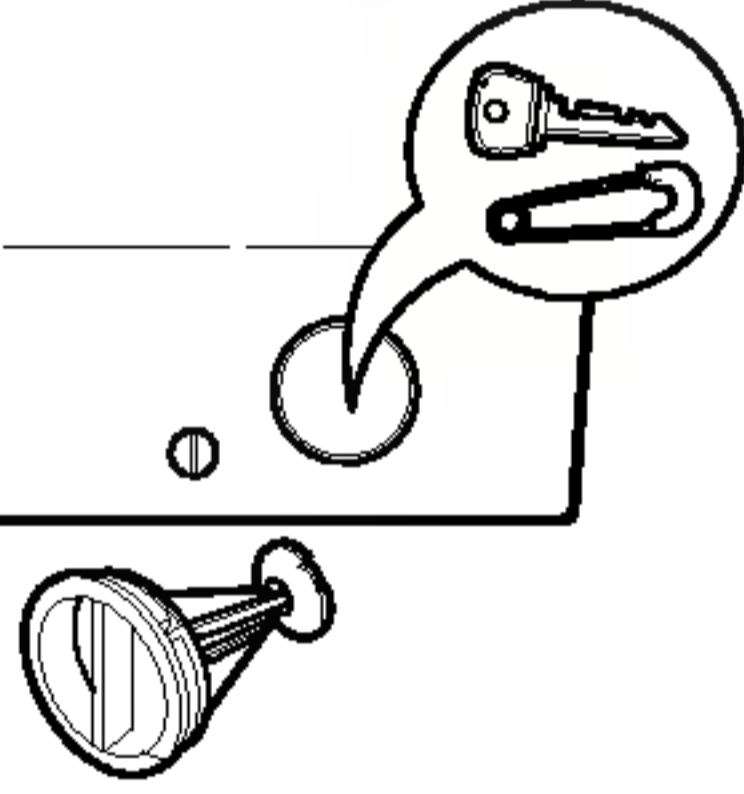
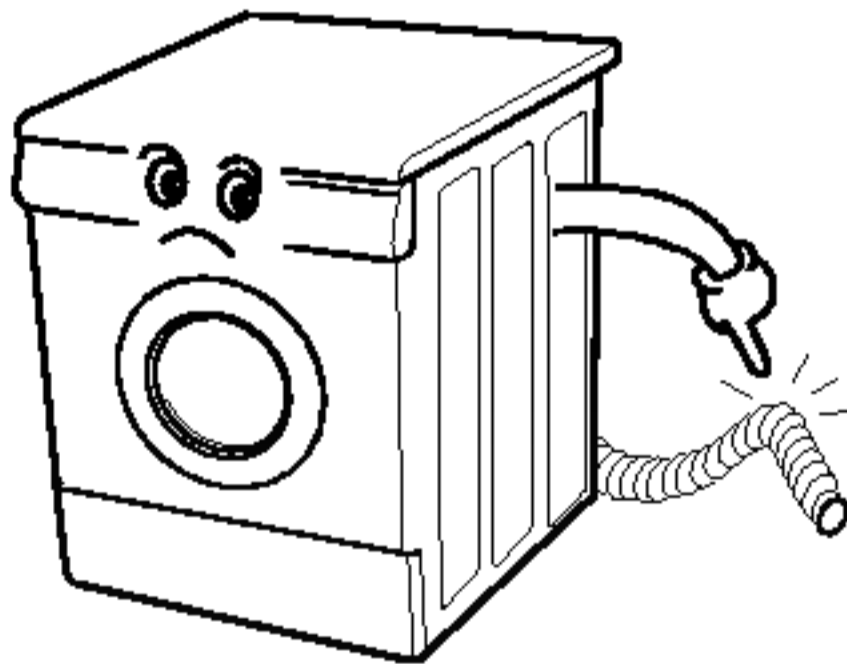
SYMPTOM	GUIDE FOR SERVICE CALL
<p>DOOR OPEN ERROR</p> 	<div style="text-align: center;"> <p>Did you press the Start/Pause button when the door is open?</p> <p><b>YES</b> → <span style="border: 1px solid black; padding: 5px;">Close the door</span></p>  </div> <div style="text-align: center; margin-top: 20px;"> <p><b>NO</b></p> <p>Visit to check</p> <p><b>Check if the door switch is O.K</b></p> </div>
<p>DRAIN TROUBLE</p> 	<div style="text-align: center;"> <p>Is  displayed?</p> <p><b>YES</b> → <span style="border: 1px solid black; padding: 5px;">Clean up the filter</span></p>  </div> <div style="text-align: center; margin-top: 20px;"> <p><b>NO</b></p> <p>Is the drain hose frozen with water, kinked, or crushed?</p> <p><b>NO</b></p> <p>Visit to check</p>  </div>

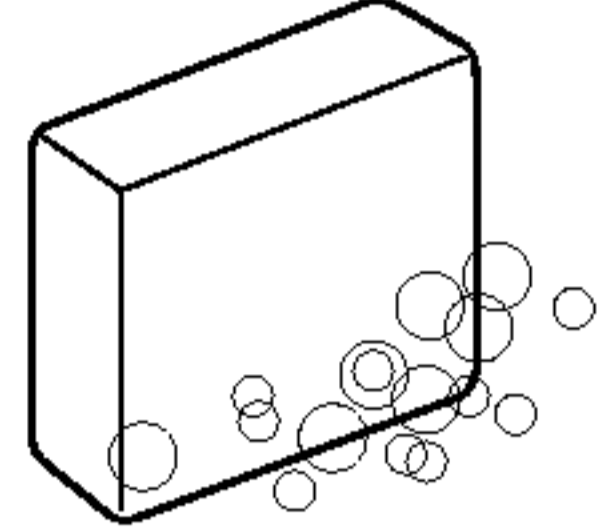
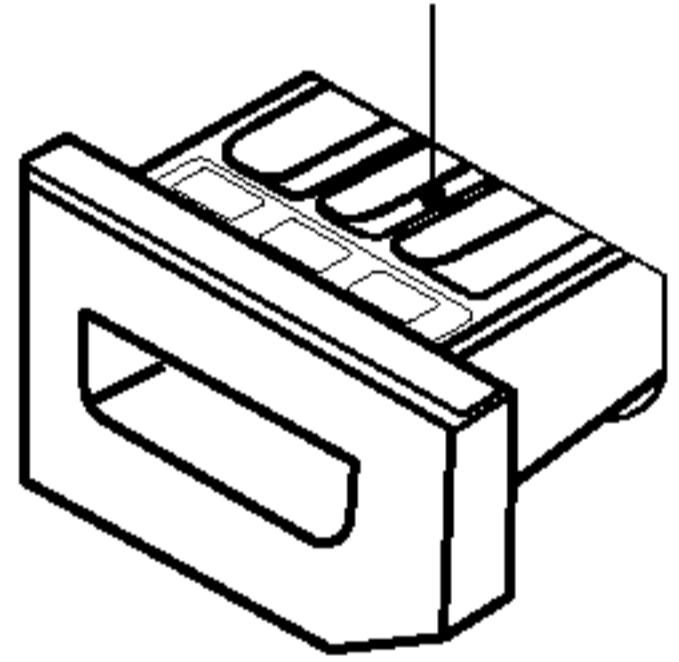
SYMPTOM	GUIDE FOR SERVICE CALL
<p>suds overflow from the appliance, (in this condition, wash and spin do not operate normally)</p>	<div style="display: flex; justify-content: space-between; align-items: flex-start;"> <div style="width: 65%;"> <p>Is low-sudsing detergent for the drum washing machine used?</p> <p style="text-align: center;"><b>YES</b></p> <p>Is the proper amount of detergent used as recommended?</p> <p style="text-align: center;"><b>YES</b></p> <p style="text-align: center;">Recommend to reduce the amount of detergent.</p> <ul style="list-style-type: none"> <li>• This appliance has the automatic suds sensing function which operates under much suds condition for good rinse and preventing overflow.</li> <li>• When much suds are sensed, the suds removing function such as drain, water input, and pause will operate without rotating the drum.</li> </ul> </div> <div style="width: 30%; text-align: center;">  <p><b>LOW-SUDSING DETERGENT</b></p> </div> </div>
<p>No effect of softener</p>	<div style="display: flex; justify-content: space-between; align-items: flex-start;"> <div style="width: 65%;"> <p>Is softener put in the correct compartment of the drawer?</p> <p style="text-align: center;"><b>YES</b></p> <p>Is the drawer closed during wash?</p> <p style="text-align: center;"><b>YES</b></p> <p>Is the softener cap clogged?</p> <p style="text-align: center;"><b>YES</b></p> <p style="text-align: center;">Explain how to use softener</p> <p style="text-align: center;"><b>Clean the compartment for softener</b></p> </div> <div style="width: 30%; text-align: center;"> <p>Compartment for softener</p>  </div> </div>
<div style="display: flex; flex-direction: column; align-items: center;"> <div style="display: flex; gap: 10px; margin-bottom: 5px;"> <div style="border: 1px solid black; border-radius: 5px; padding: 2px 5px;">FE</div> <div style="border: 1px solid black; border-radius: 5px; padding: 2px 5px;">CE</div> </div> <div style="display: flex; gap: 10px; margin-bottom: 5px;"> <div style="border: 1px solid black; border-radius: 5px; padding: 2px 5px;">PE</div> <div style="border: 1px solid black; border-radius: 5px; padding: 2px 5px;">LE</div> </div> <div style="display: flex; gap: 10px;"> <div style="border: 1px solid black; border-radius: 5px; padding: 2px 5px;">EE</div> <div style="border: 1px solid black; border-radius: 5px; padding: 2px 5px;">AE</div> </div> </div>	<p style="text-align: center;">Visit to check</p>

## 8-2. FAULT DIAGNOSIS AND TROUBLESHOOTING

1. Be careful of electric shock or disconnecting the parts while troubleshooting.
2. First of all, check the connection of each part terminal with wiring diagram.
3. If you replace the MAIN PWB ASSEMBLY, put in the connectors correctly.

### NO POWER

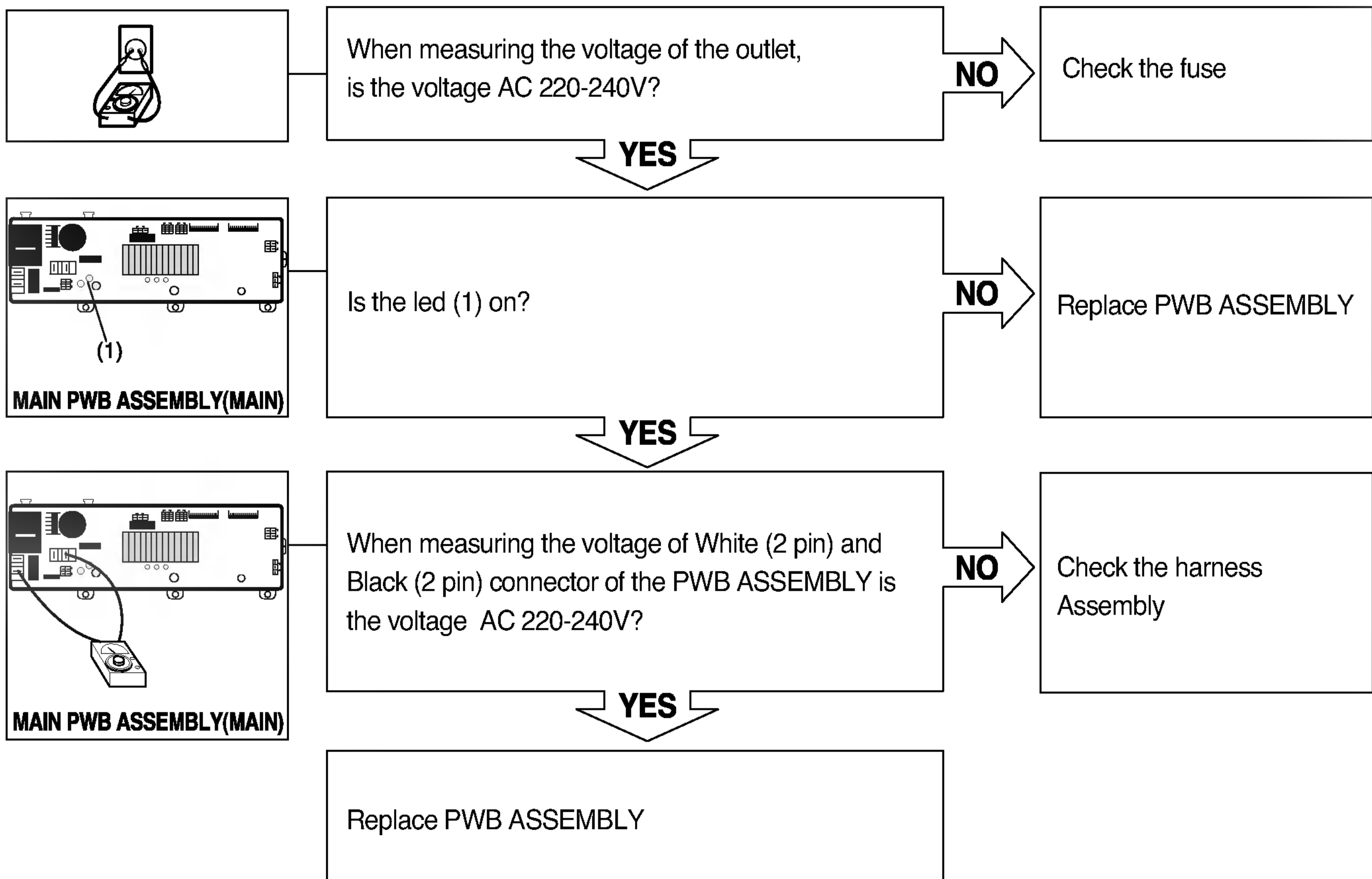

## NO WATER SUPPLY

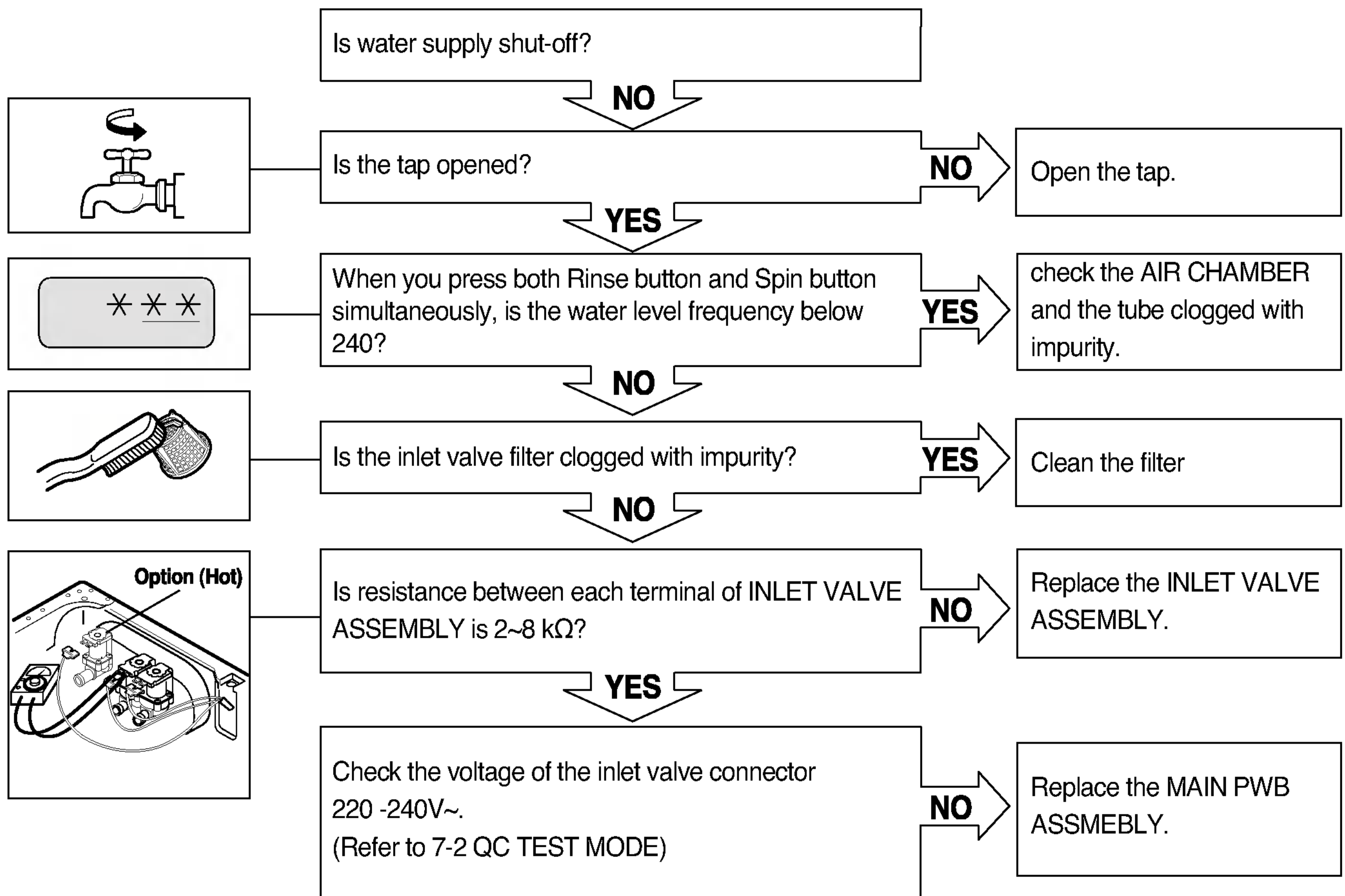

## DETERGENT DOES NOT FLOW IN

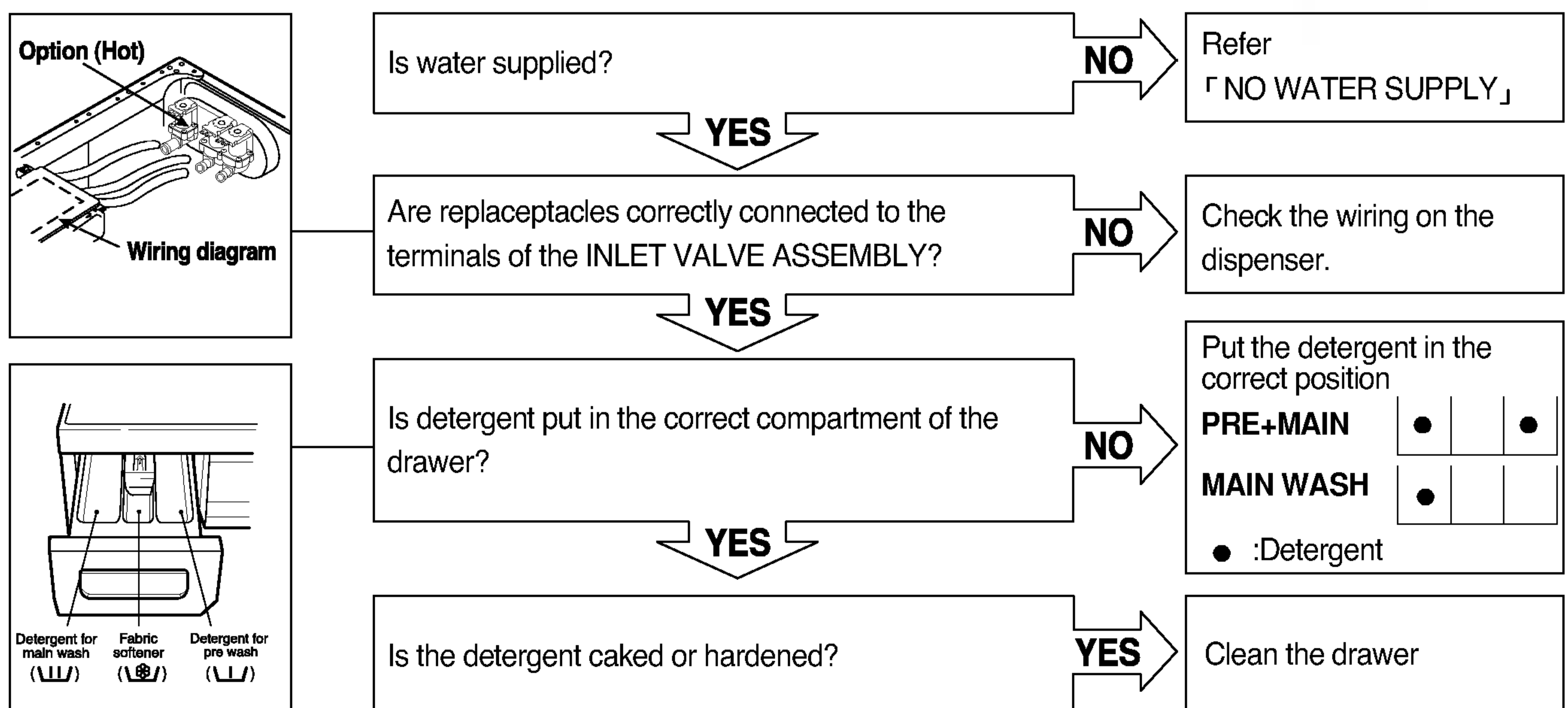

## SOFTENER DOES NOT FLOW IN

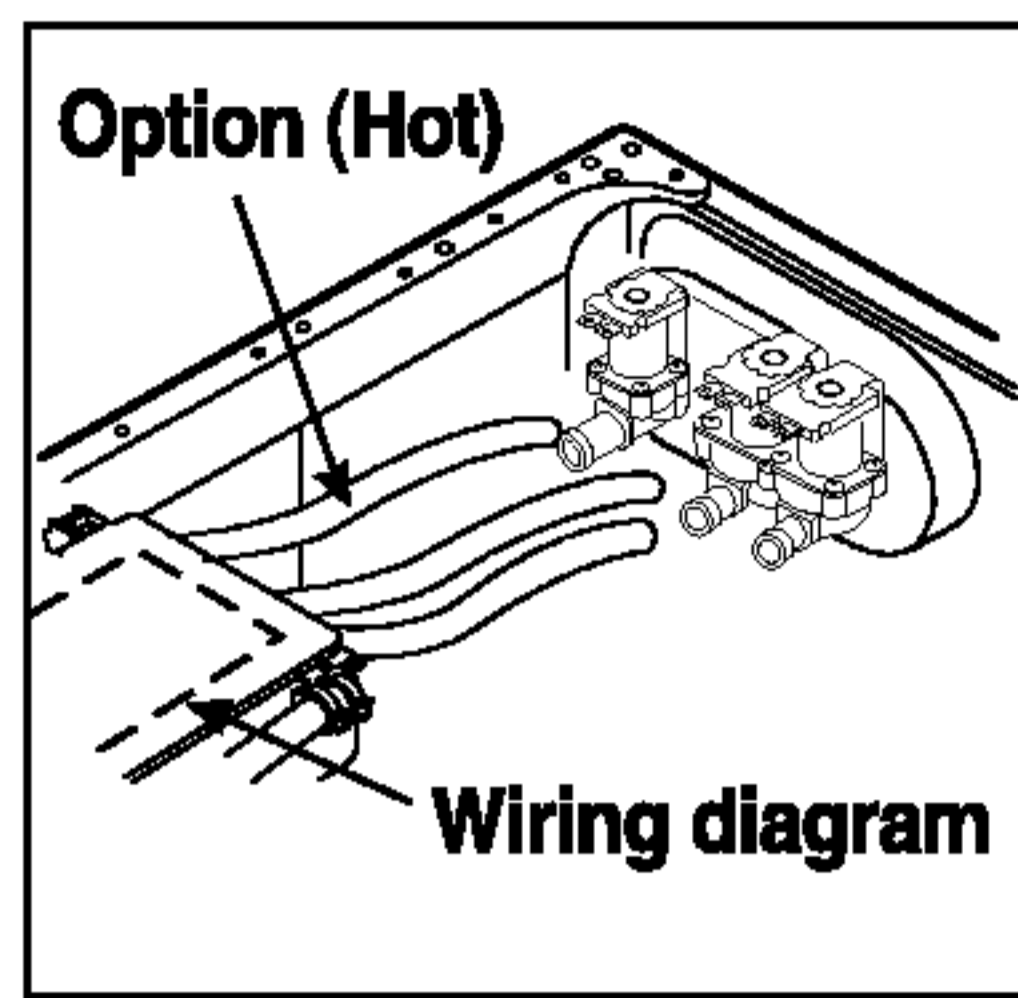

Is water supplied?

**NO**

Refer to  
「NO WATER SUPPLY」

**YES**

Are receptacles correctly connected to the terminals  
of the INLET VALVE ASSEMBLY?

**NO**

Check the wiring on the  
dispenser.

**YES**

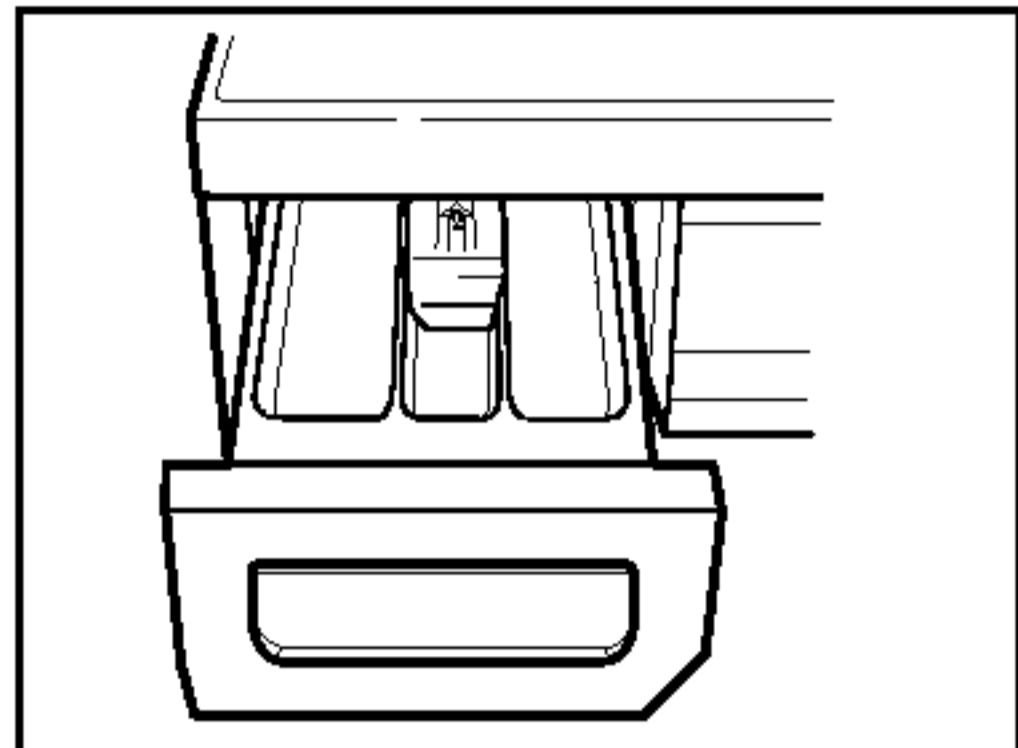

Is softener put in the correct compartment of the  
drawer?

**NO**

Put it in the correct  
compartment.

**YES**

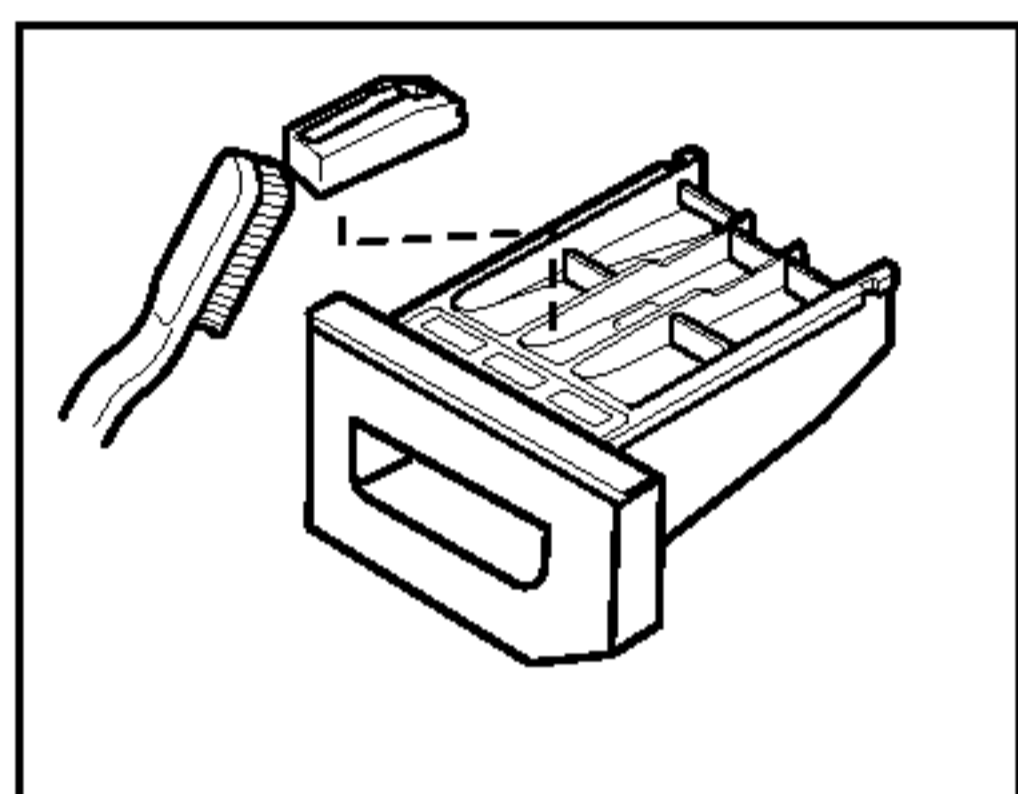

Is the softener cap clogged?

**YES**

Clean the cap and drawer.

## ABNORMAL SOUND

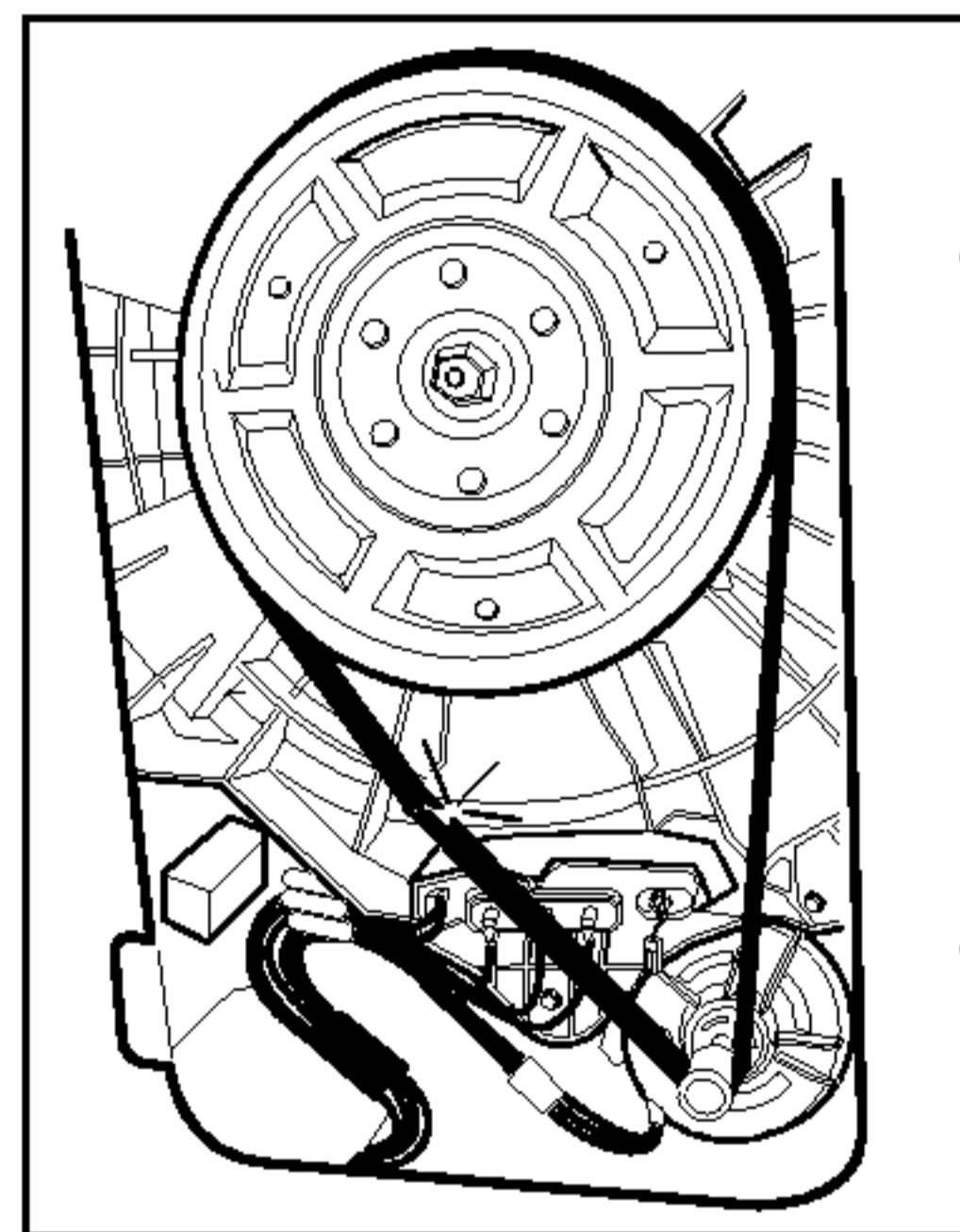

Is the motor bolt loosened?

**YES**

Fix the bolt tightly.

**NO**

Is there friction noise from the motor?

**YES**

Replace the STATOR  
ASSEMBLY or ROTOR  
ASSEMBLY

## HEATING WITHOUT WATER

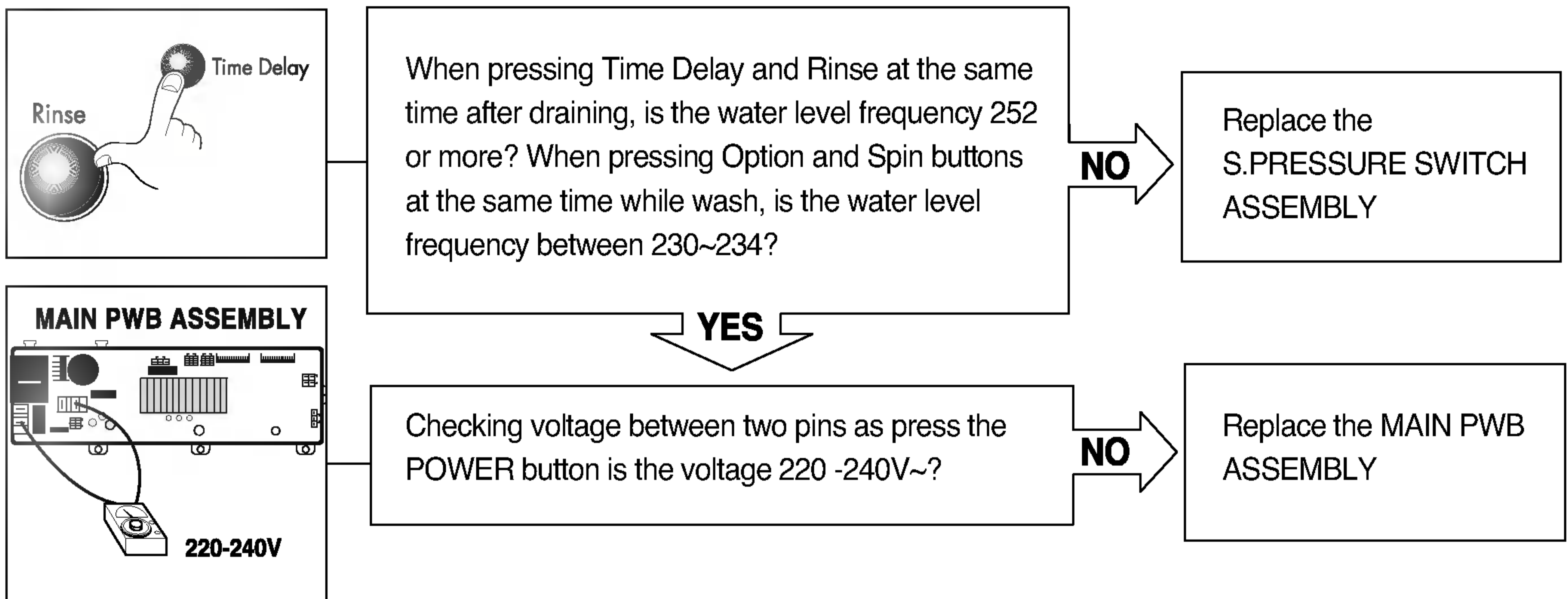

## DRAIN MALFUNCTIONING

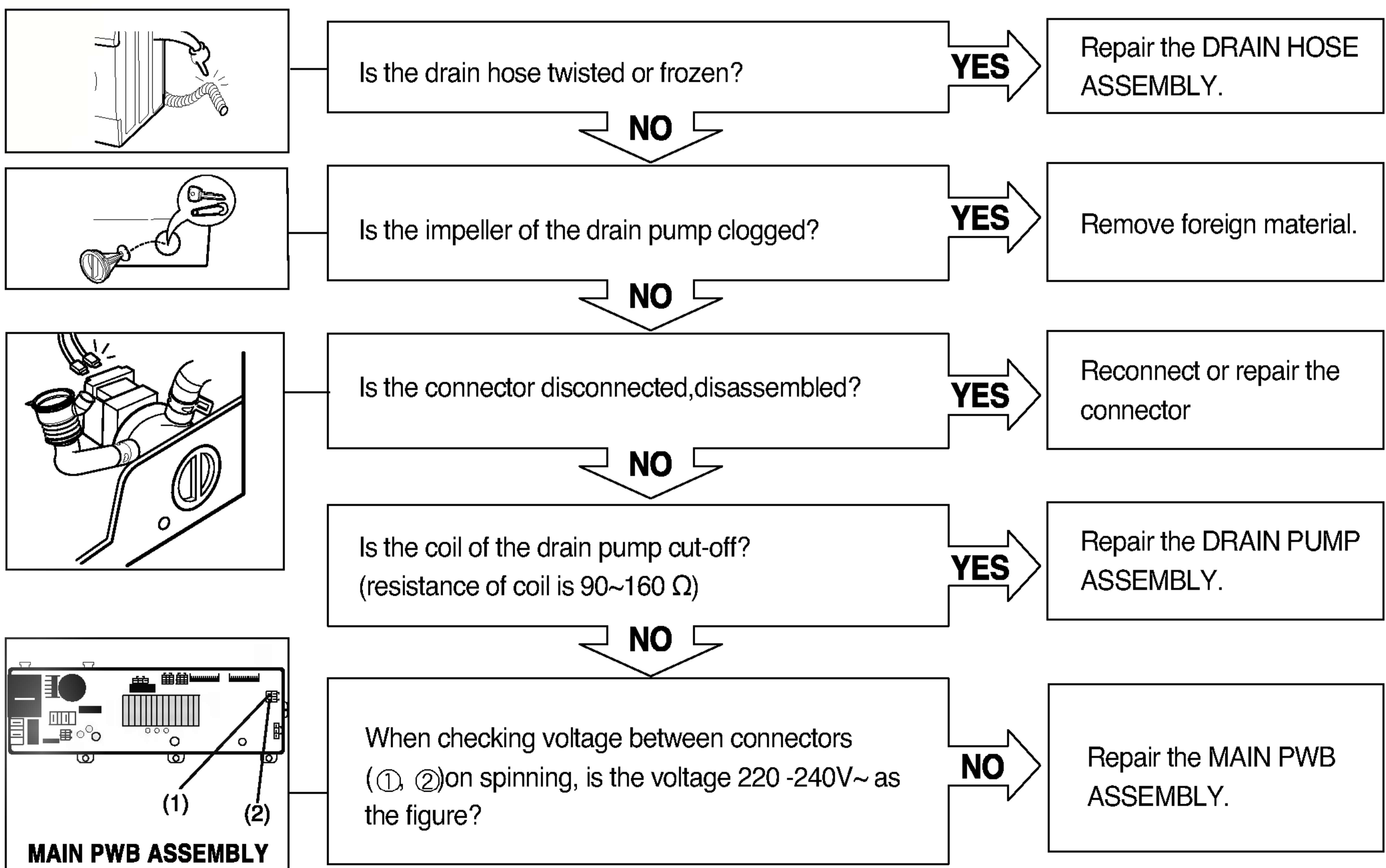

## WASH HEATER TROUBLE

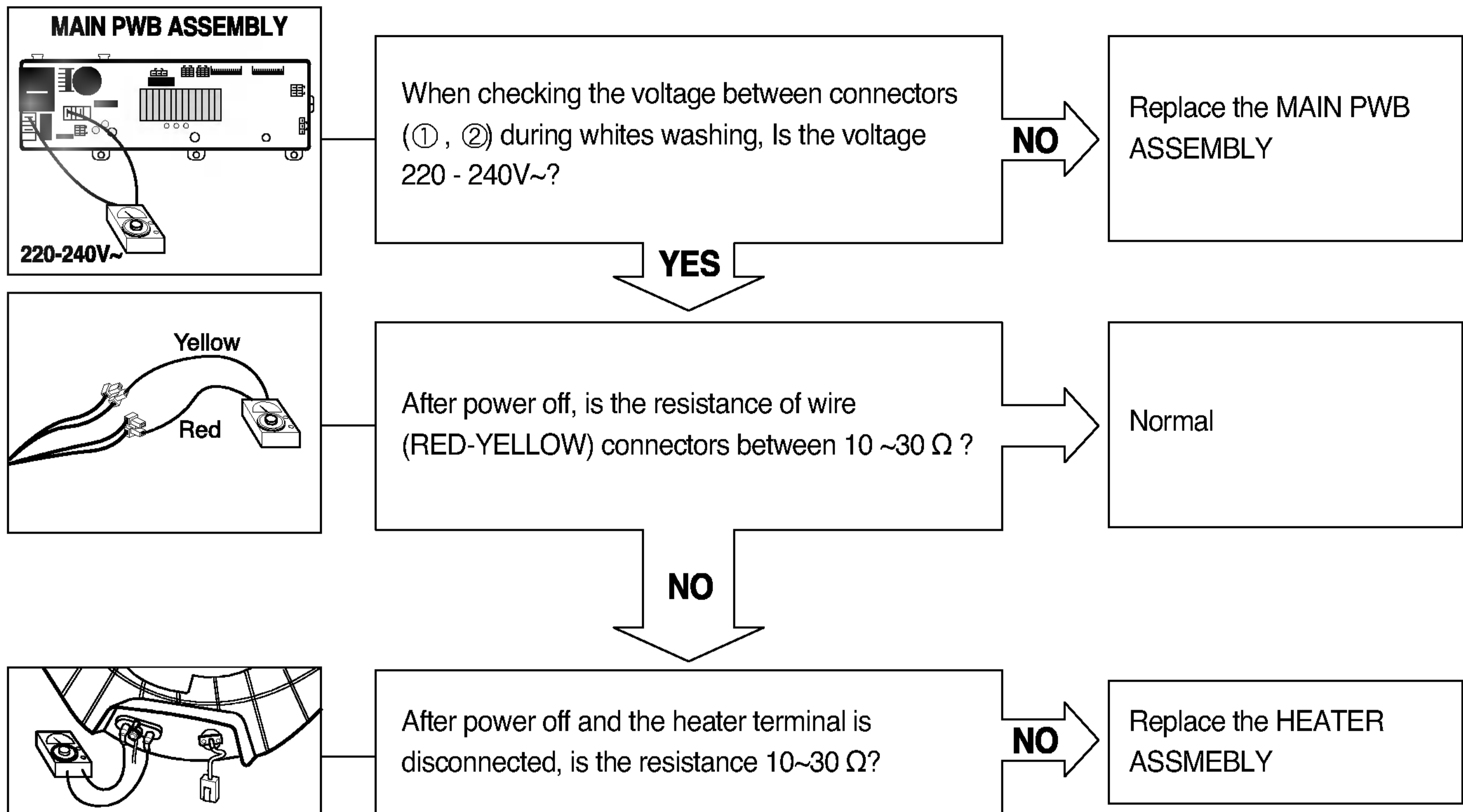

## HEATING CONTINUOUSLY ABOVE THE SETTING WATER TEMPERATURE

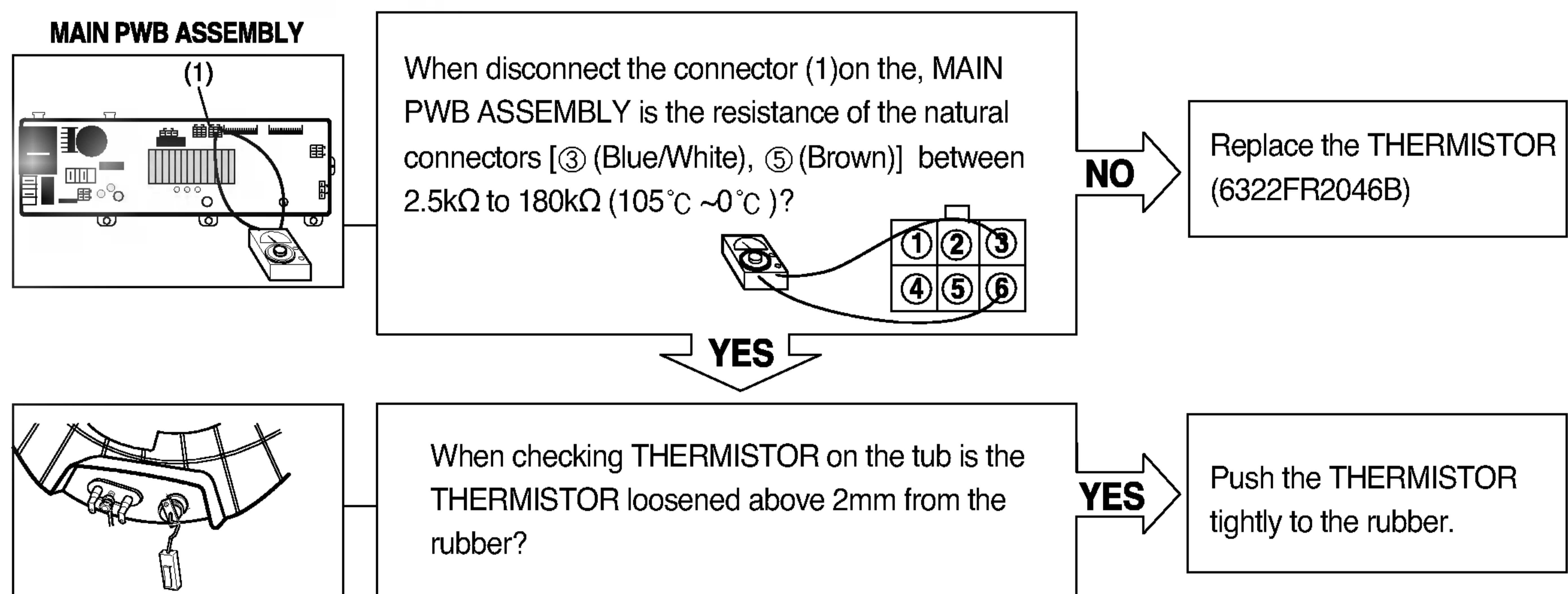

## SPIN TROUBLE

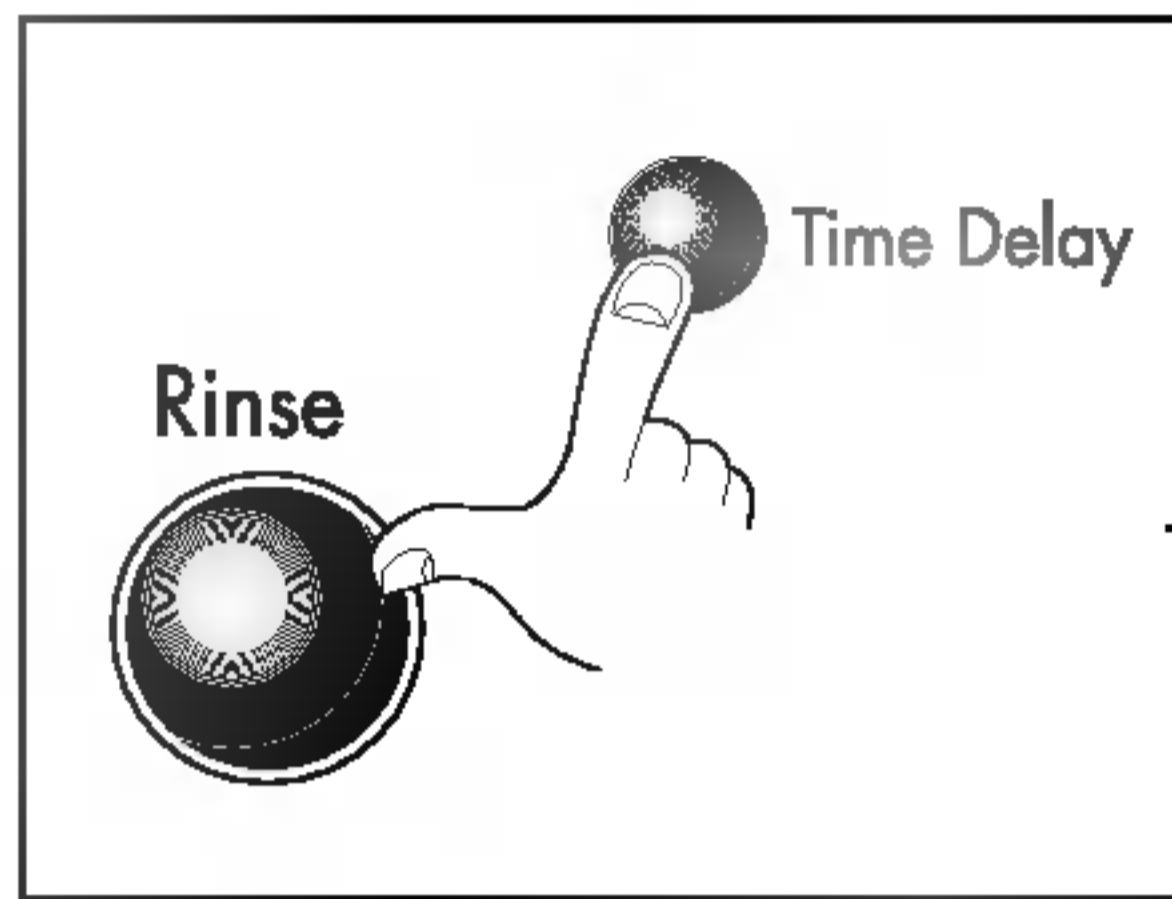

Check on the spinning, is the frequency of the water level 248 or more. The frequency can be checked by pressing the Time Delay and Rinse buttons at the same time on the program.

**NO**

Check the sensor (Pressure) or hose (Sensor). If the problem is on the sensor or the hose, replace the sensor or the hose.

**YES**

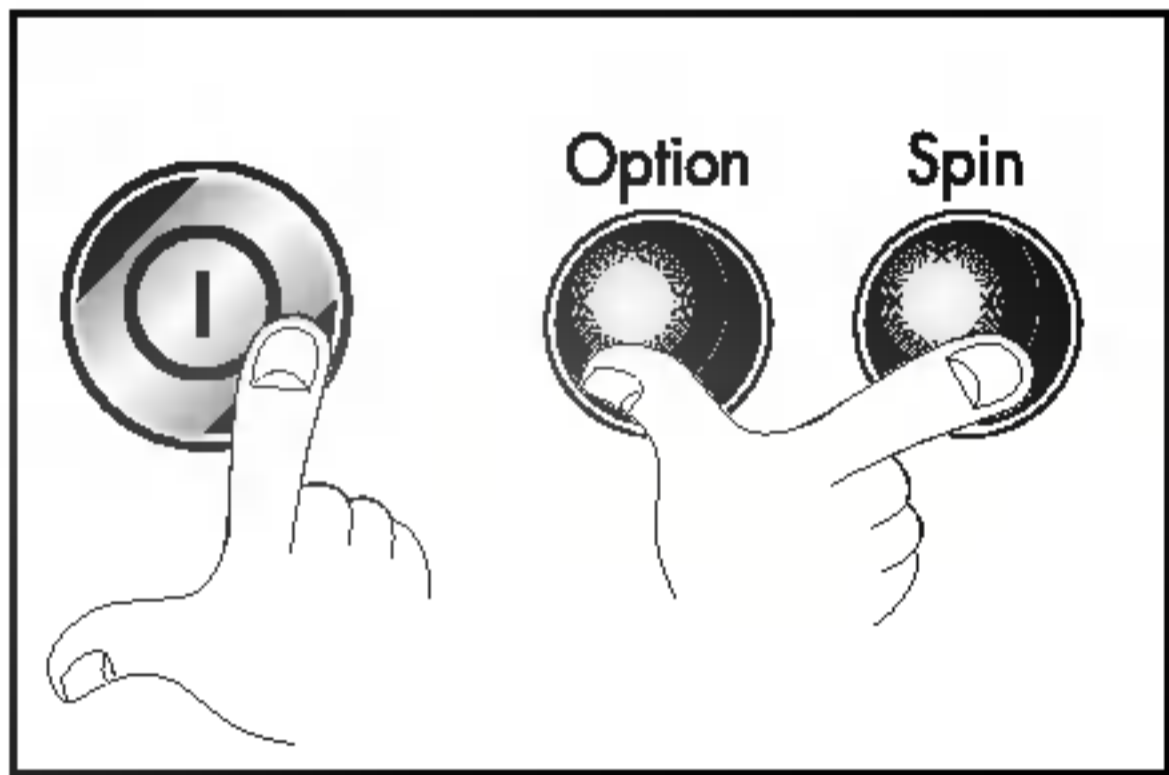

When pressing Option, Spin and POWER buttons at the same time after power off, press the Start/Pause button 2 times, is the drum low speed spin?

**YES**

Normal

**NO**

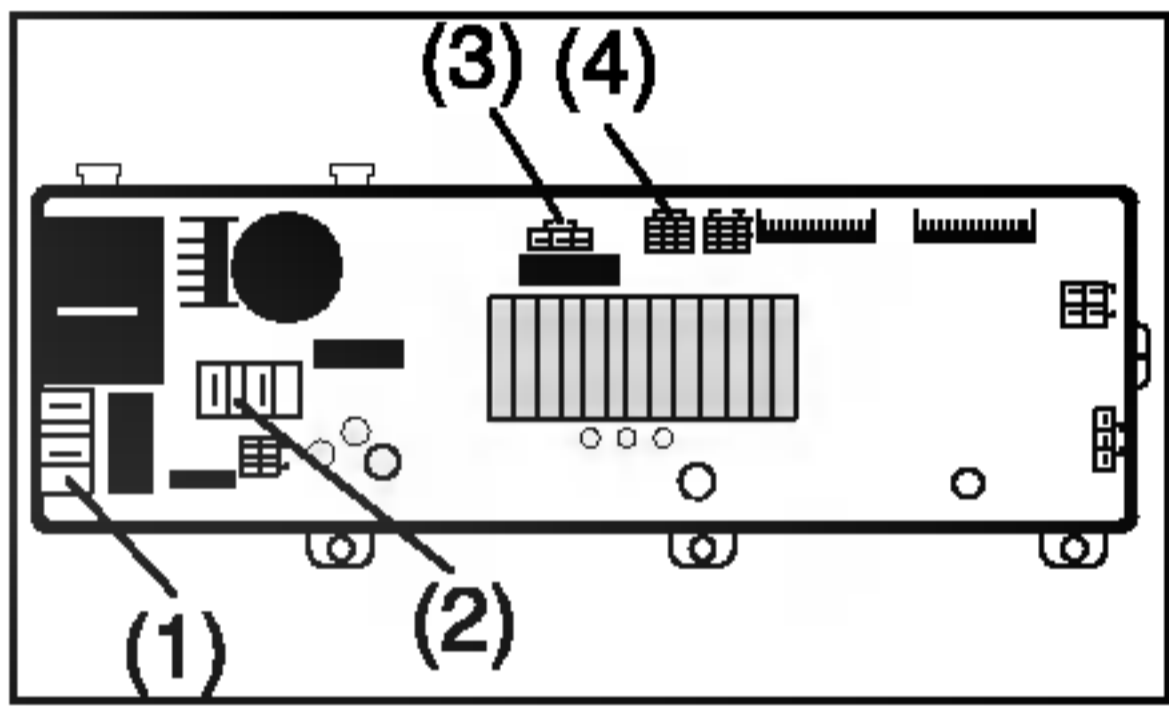

Is it disconnected, or disassembled?  
[White : 2pin(①), Black: 2pin(②), Red : 3pin(③), National : 6pin(④)]

**YES**

Correct the connector

**NO**

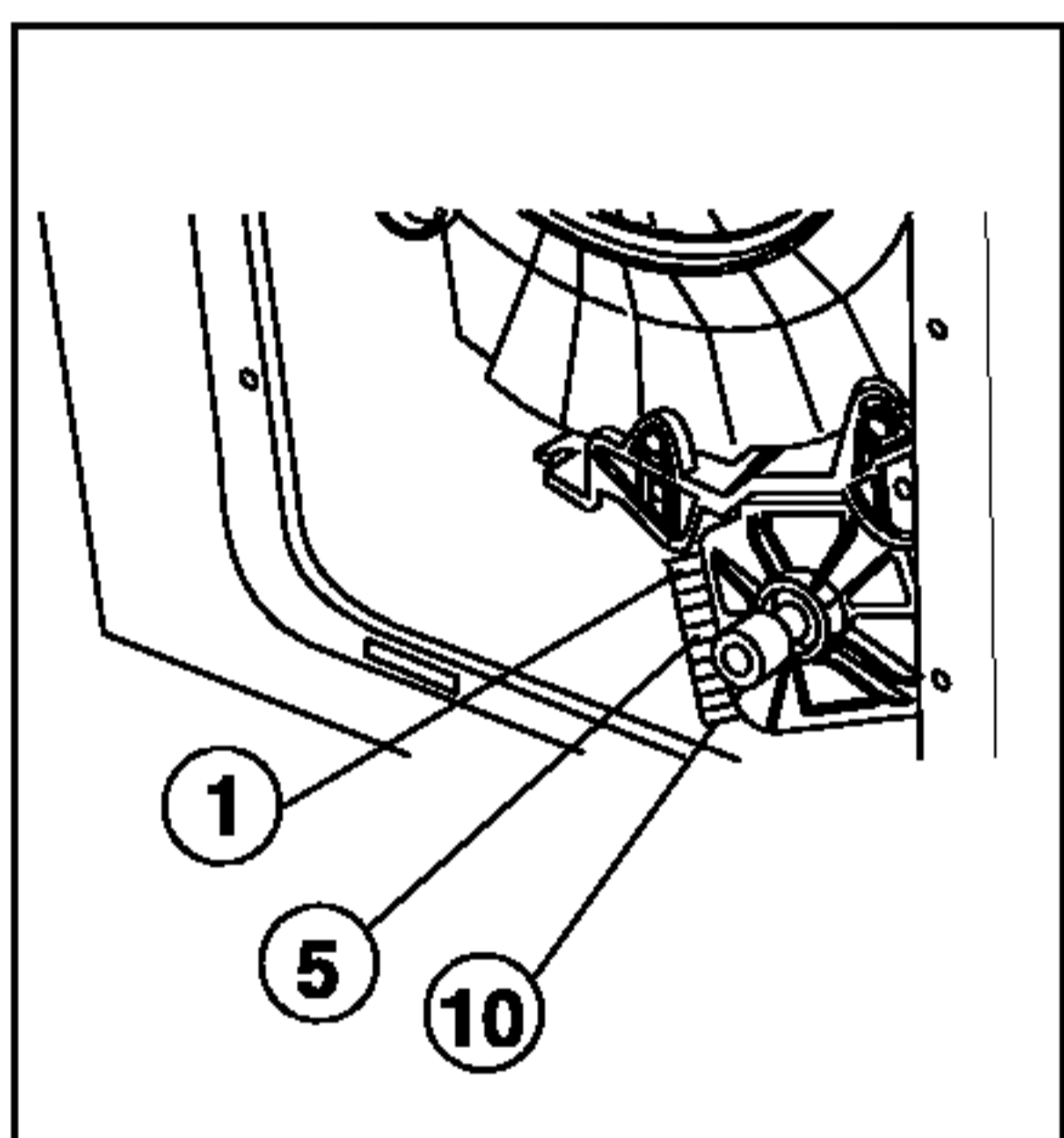

Is it disconnected, or disassembled?  
[White : 3pin (①), National : 4pin (②)]

**YES**

Correct the connector

**NO**

Check the motor connector, Is the resistance of the terminal same as the figure?

**MOTOR TERMINAL (1)**

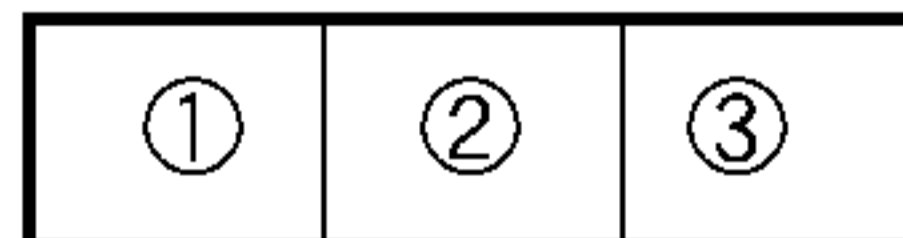

Resistance of terminal :

①~② / ②~③ / ③~① : About 5Ω ~ 10Ω

**NO**

Replace the Motor Assembly (4681ER1003A)

**YES**

Replace the MAIN PWB ASSEMBLY



# 9. DISASSEMBLY INSTRUCTIONS

\* Be sure to unplug the machine out of the outlet before disassembling and repairing the parts.

## CONTROL PANEL ASSEMBLY

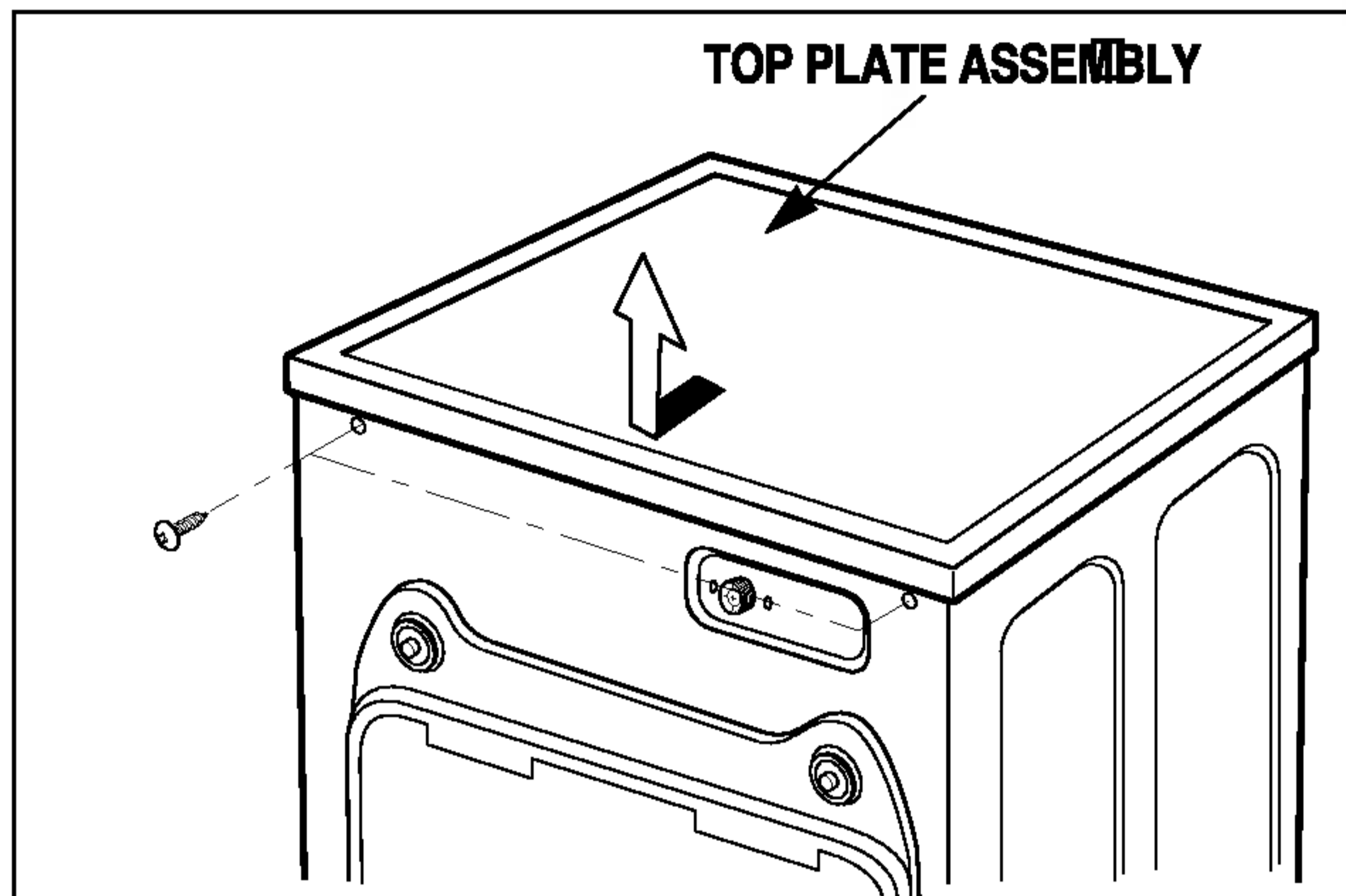

- ① Unscrew 2 screws on the back of the top plate.
- ② Pull the top plate backward and upward as shown.

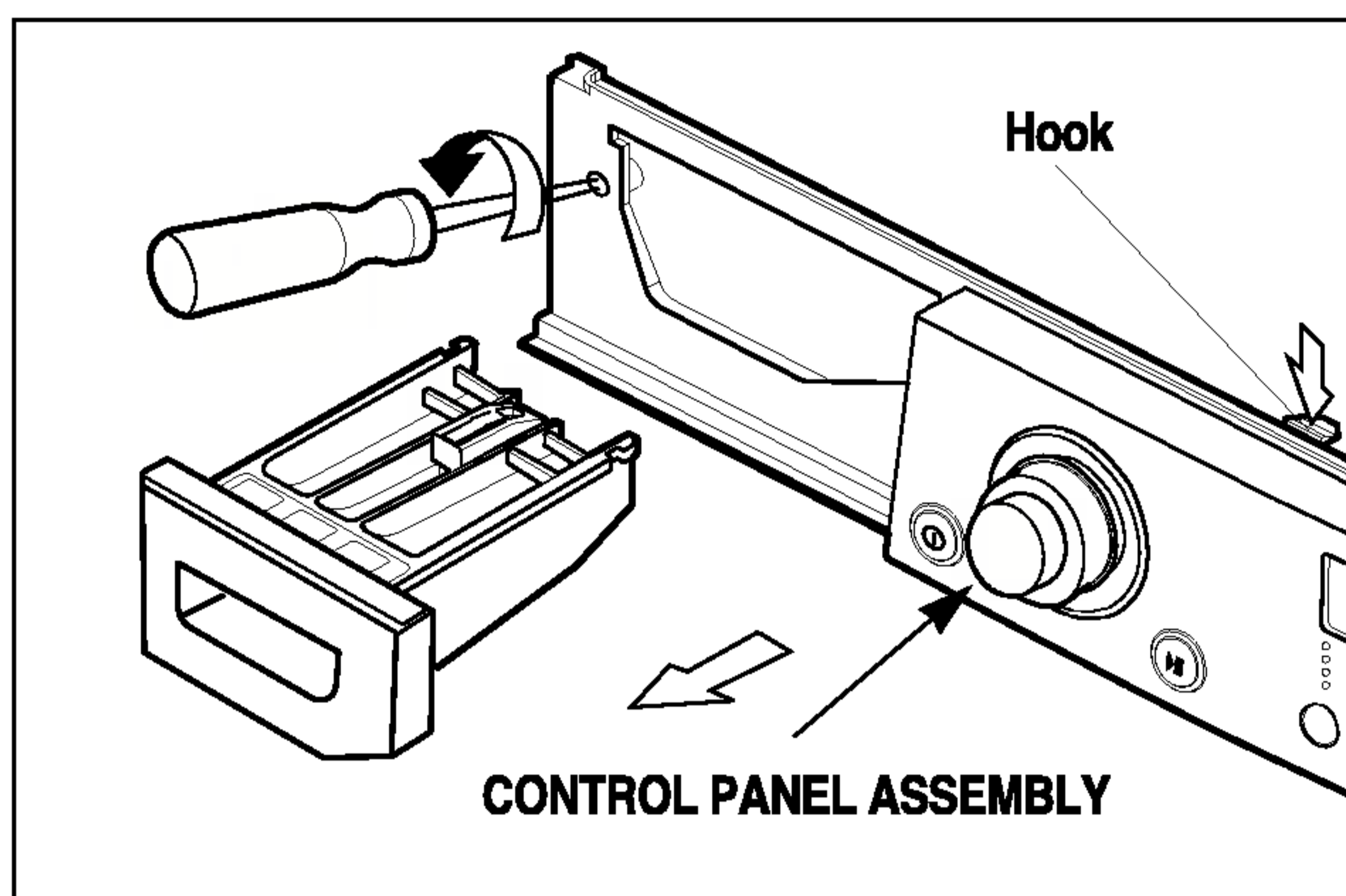

- ① Disconnect the ASSEMBLY connector.
- ② Pull out the drawer and unscrew 2 screws.
- ③ Push 2 upper hooks down and pull the control panel.

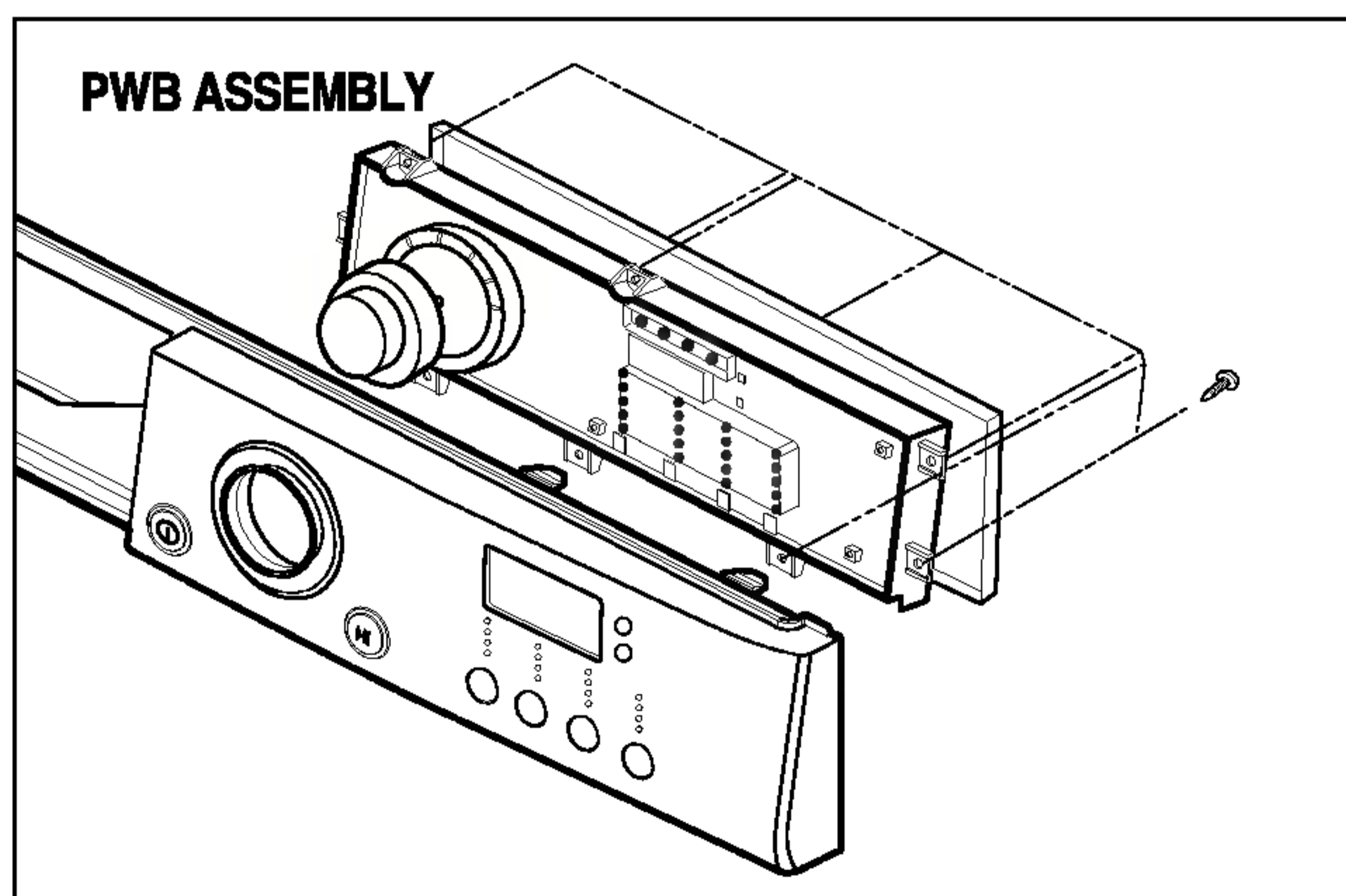

- ① Disconnect the PWB ASSEMBLY from the control panel by unscrewing 7 screws.

## DISPENSER ASSEMBLY

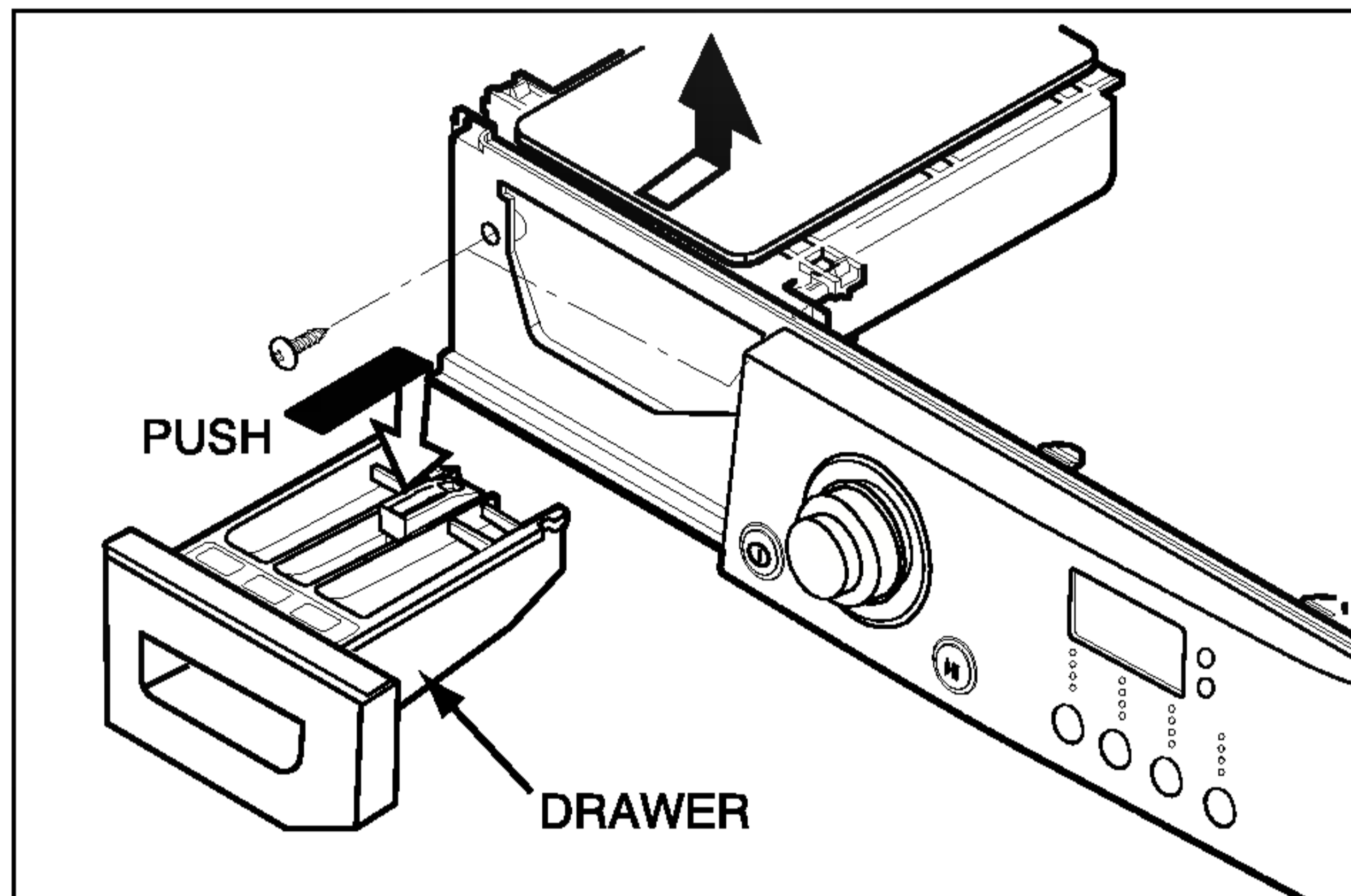

- ① Disassemble the TOP PLATE ASSEMBLY.
- ② Pull out the drawer slightly upward.
- ③ Unscrew 2 screws.

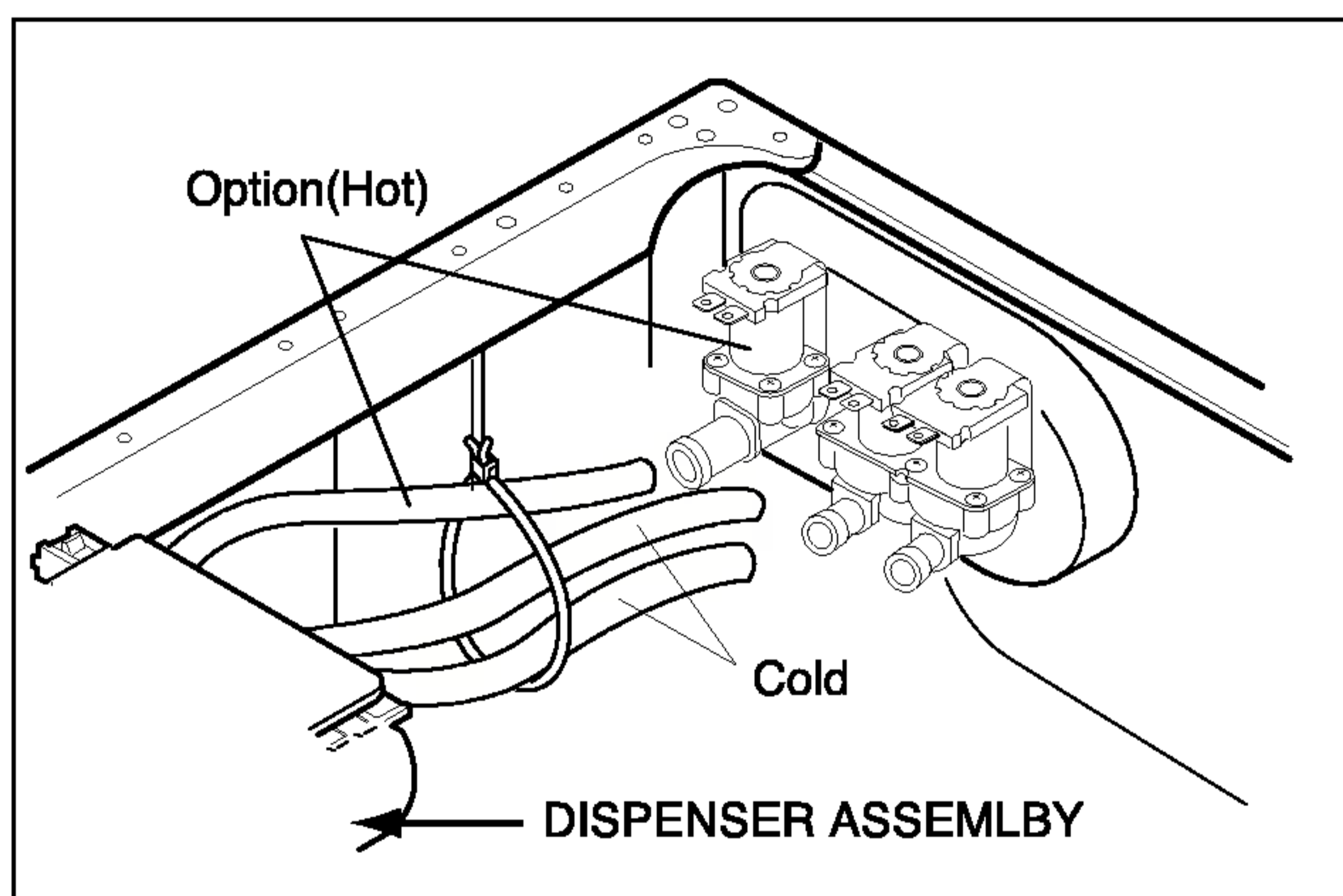

- ① Disassemble hose clamps and hoses.
- ② Disassemble the ventilation bellows and the water inlet bellows from the tub.

## INLET VALVE ASSEMBLY

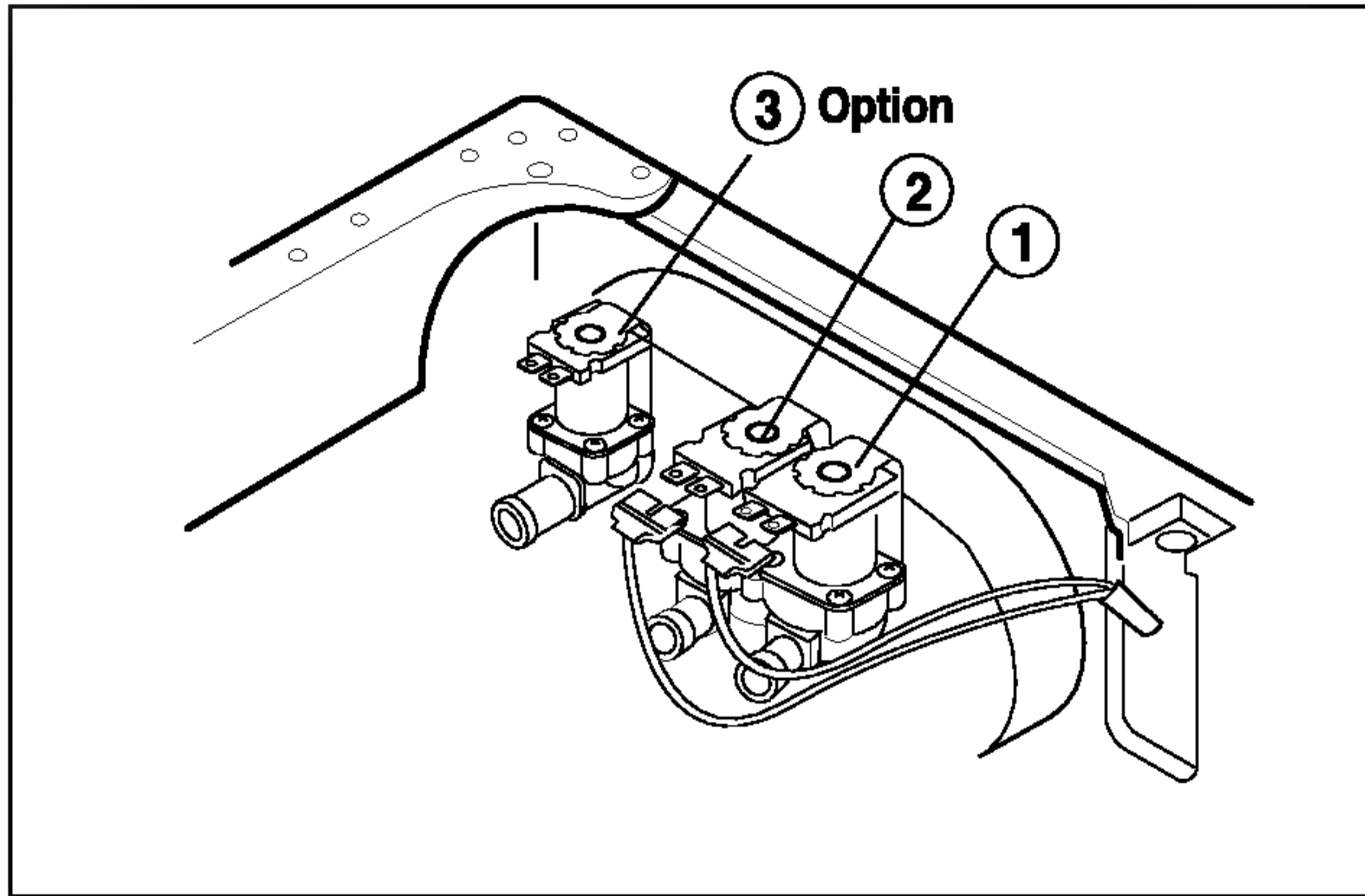

- ① Disconnect the wiring connector.
- ② Unscrew 2(4) screws from the back.

\* When reconnecting the connector

\* Cold only model

VALVE #1 (MAIN)	Whited/Black-Black
VALVE#2 (PRE)	Gray/White-Black

\* Cold only model

VALVE #1 (MAIN)	Whited/Black-Black
VALVE#2 (PRE)	Gray/White-Black
VALVE#3 (HOT)	Blue/Red-Black

## LOWER COVER

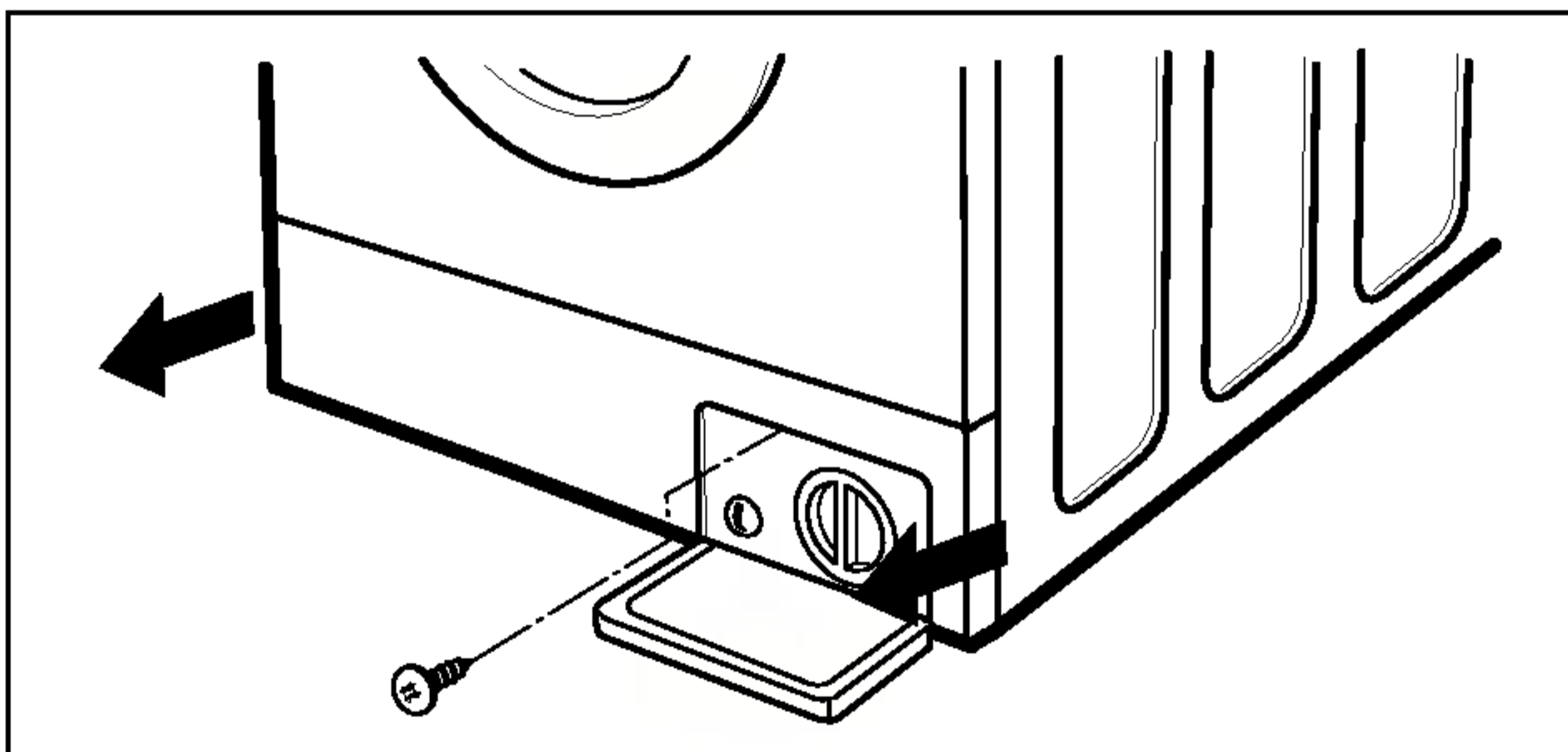

- ① Open the lower cover CAP by using coin and pull out the lower cover in the arrow direction after a screw is unscrewed.

## DOOR ASSEMBLY

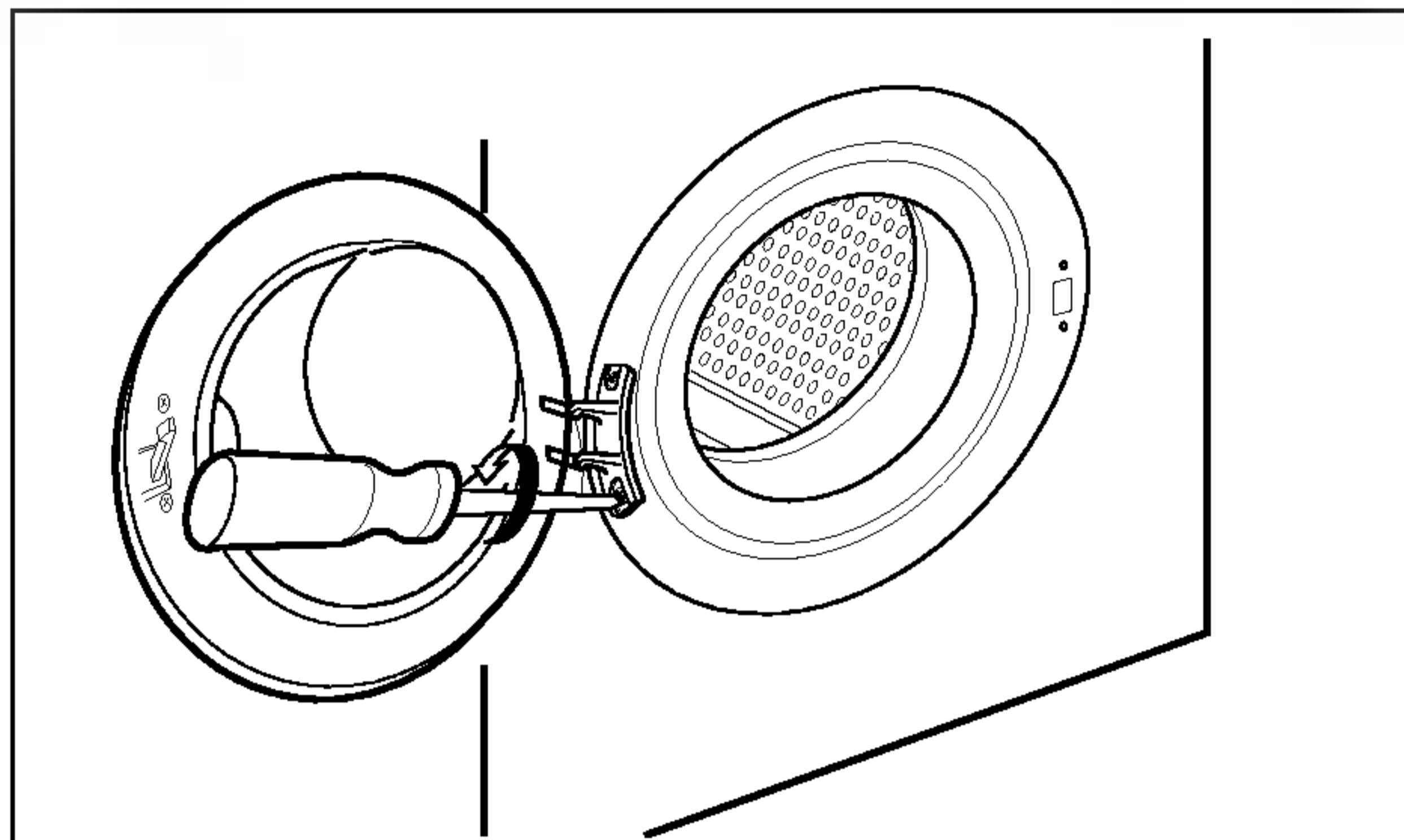

- ① Open the door completely.
- ② Remove the two screws from the hinge.

※ When removing the DOOR ASSEMBLY, it is necessary to hold the BRACKET that is inner of the CABINET COVER.

## GASKET

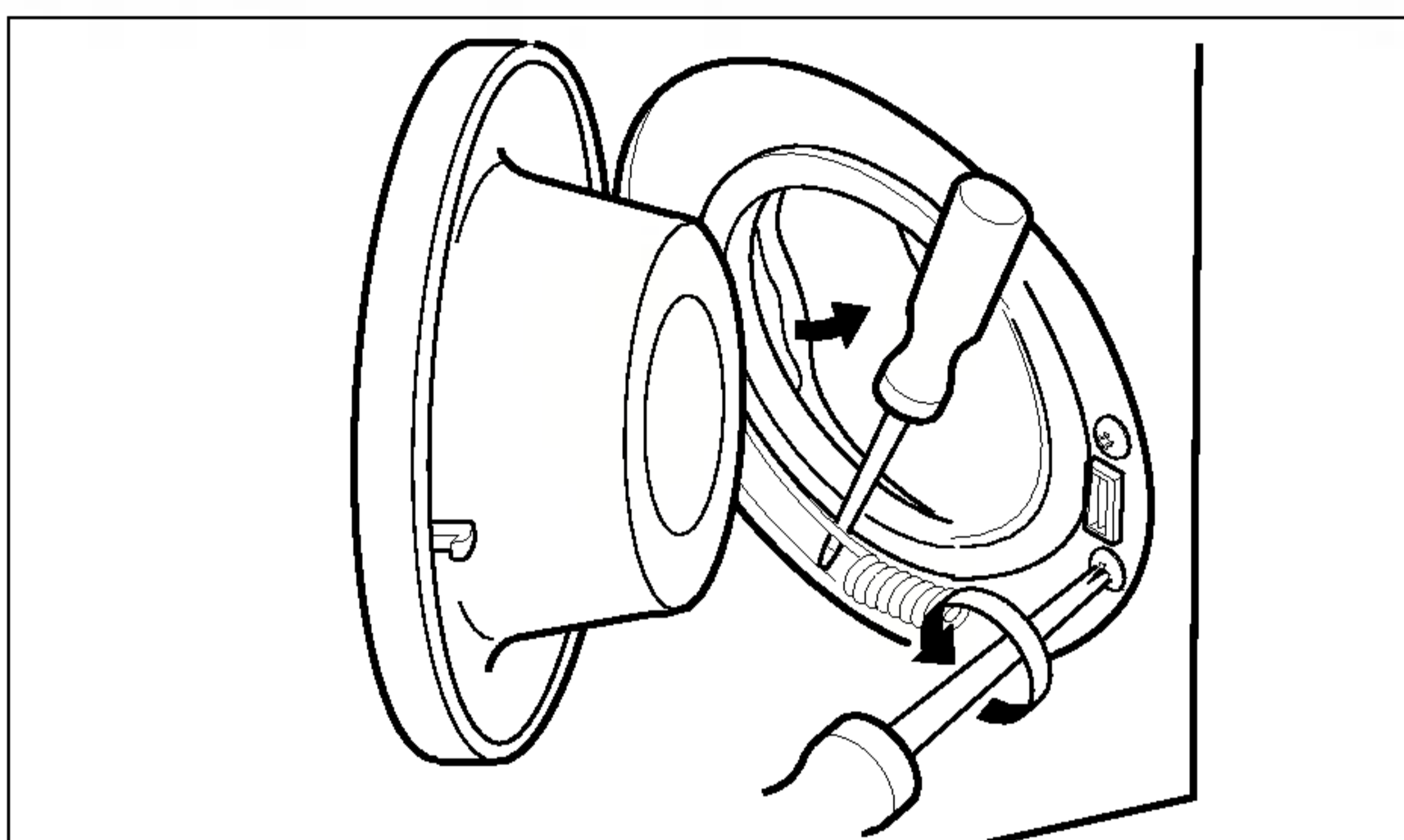

- ① Take apart the CLAMP ASSEMBLY (cabinet).
- ② Unscrew 2 screws from the CABINET COVER.
- ③ Open the lower cover cap and unscrew 1 screw inside (Refer to page 27)
- ④ Take apart the LOWER COVER.

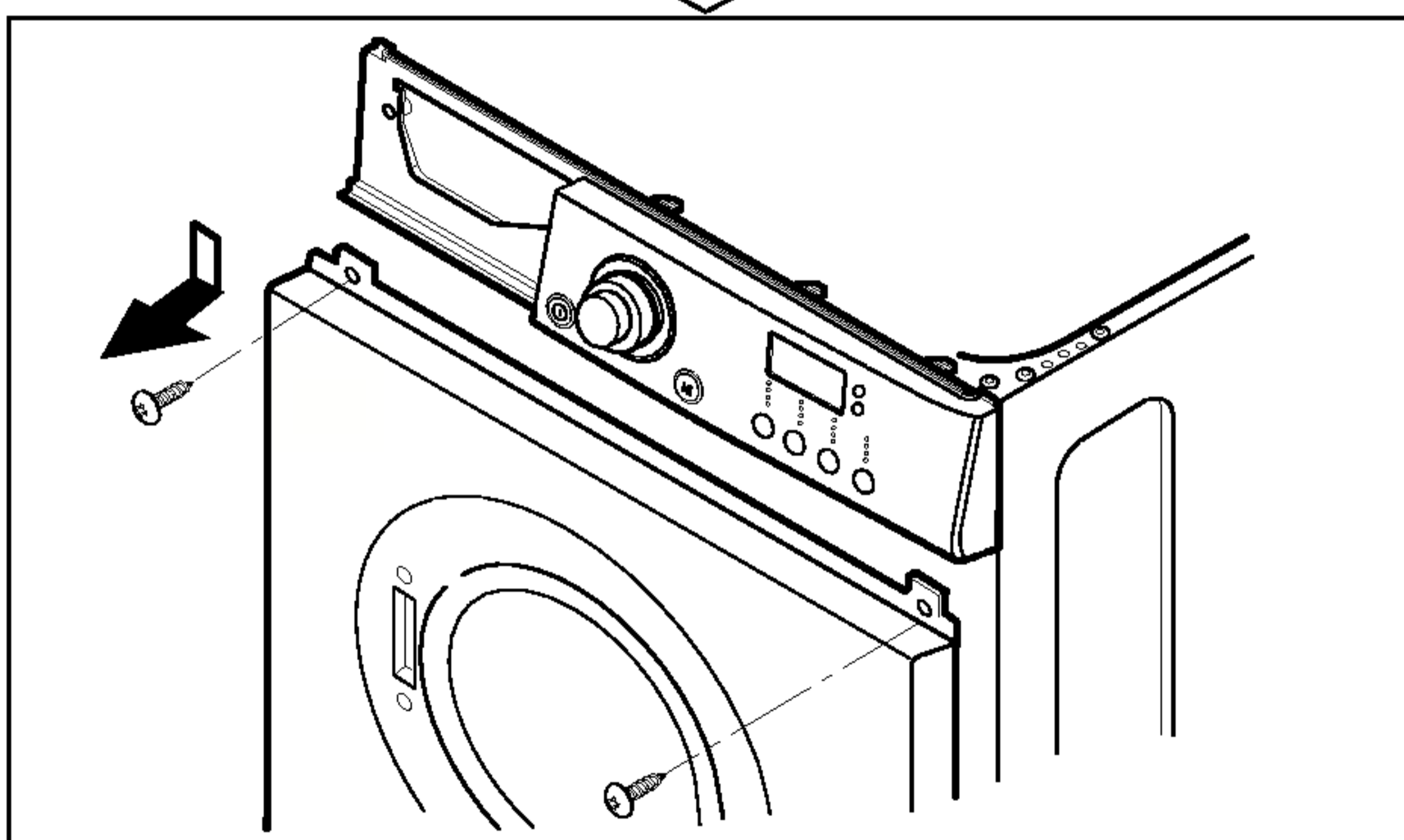

- ① Disassemble the CONTROL PANEL ASSEMBLY. (Refer to page 25)
- ② Unscrew all the screws on the upper and lower sides of the CABINET COVER.

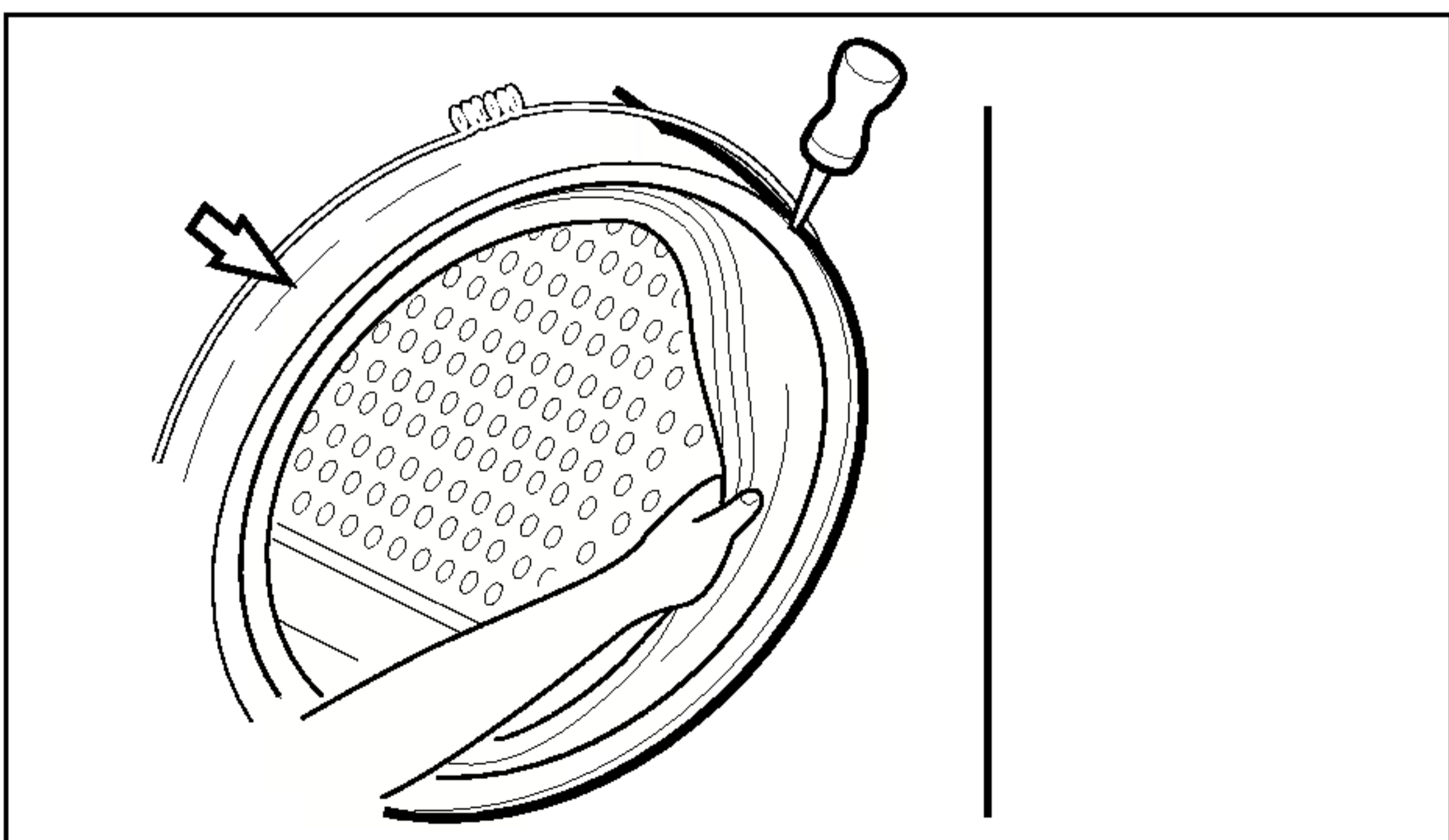

- ① Take apart the tub CLAMP ASSEMBLY
- ② Make sure that the drain hole of the GASKET is put beneath when reassembling the GASKET.

※ Refer to the arrow mark on the TUB COVER.

## ROTOR ASSEMBLY, STATOR ASSEMBLY, FRICTION DAMPER ASSEMBLY

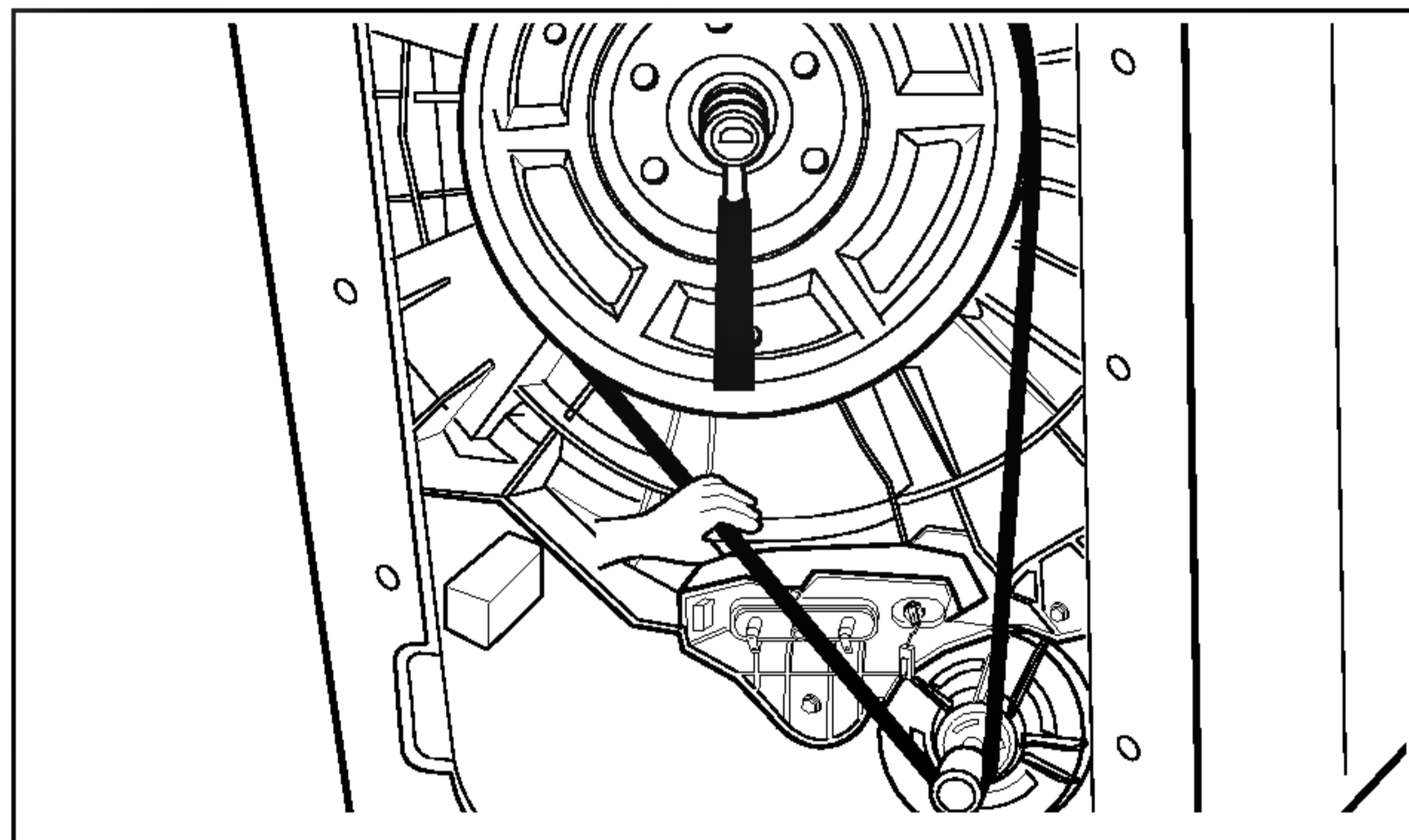

(PULLEY)

- ① Remove the back cover.
- ② Take off the belt turning the pulley.
- ③ Unscrew the bolt to pull out the pulley.

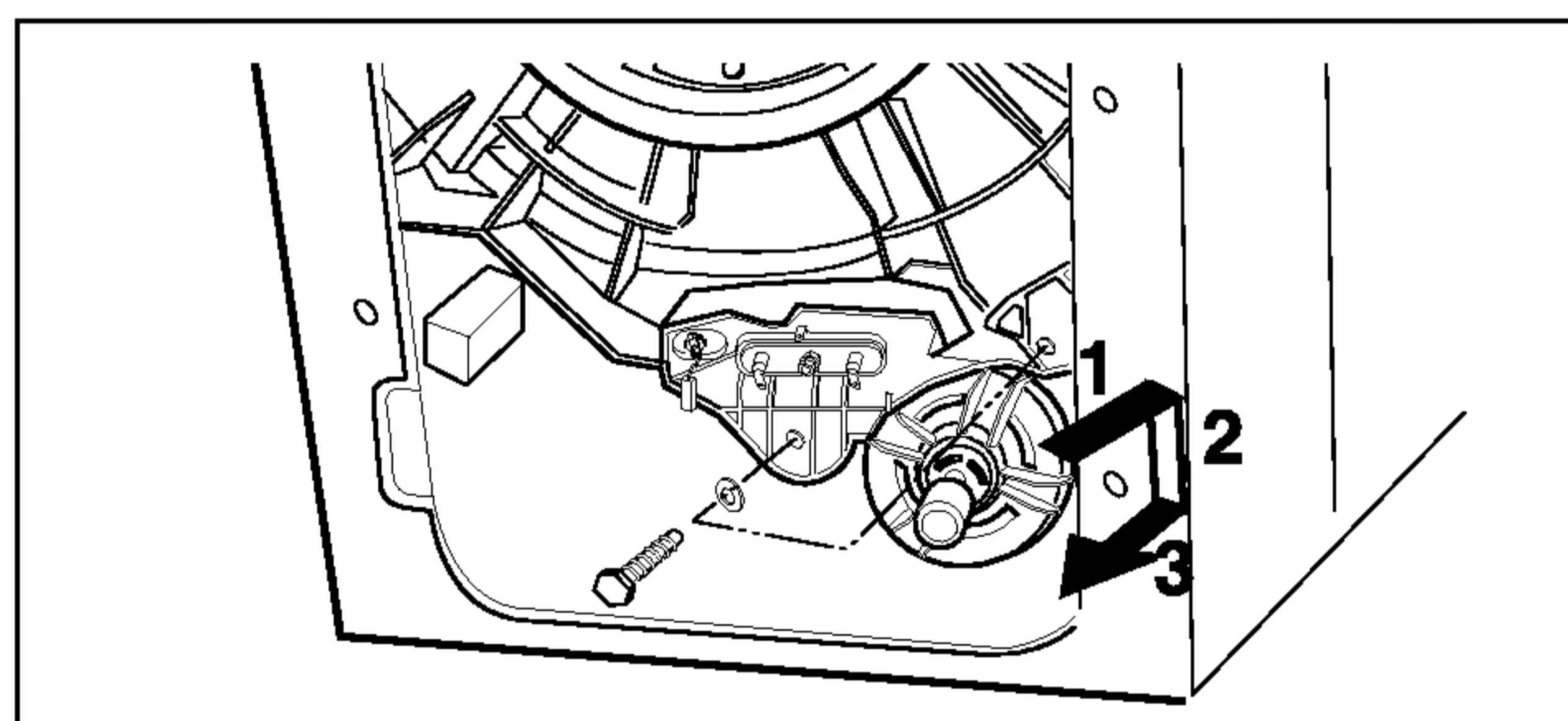

(MOTOR)

- ① Unscrew 2 screws from the bracket.
- ② Push the motor in the arrow direction for disassembling and take out it at the front of the Washing Machine.
- ③ When reassembling the motor, make sure that motor mounting bushings are not taken off from the bracket.

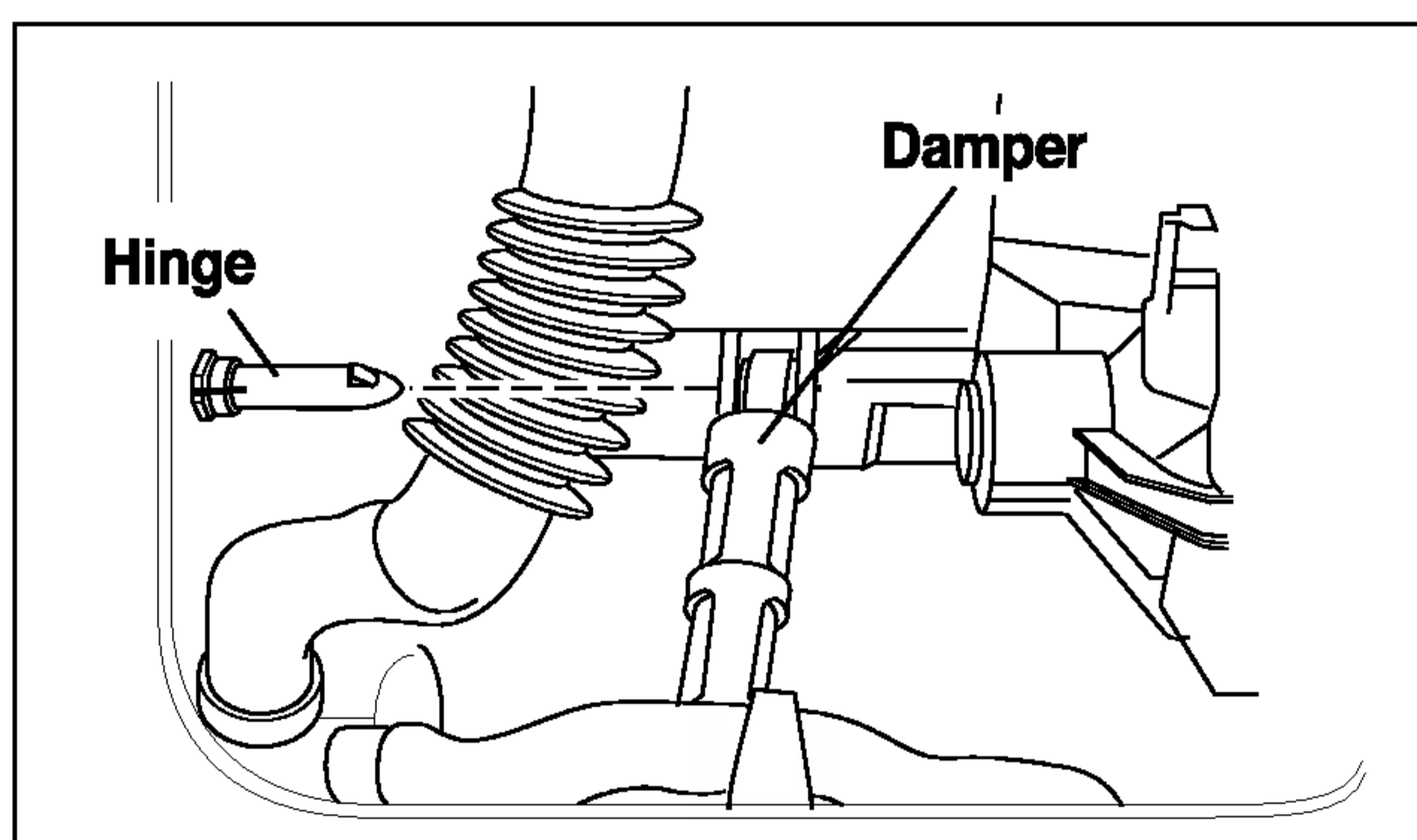

(FRICTION DAMPER ASSEMBLY)

- ① Pull out the HINGE, pressing its snap.
- ② Do not use the pulled out HINGE again. It may be taken off during operation.

### ■ Clean the drain pump filter

1. Open the lower cover cap (①) by using a coin. Turn the drain plug (②) to pull out the hose.

2. Unplug the drain plug (②), allowing the water to flow out. At this time use a vessel to prevent water flowing on to the floor. When water does not flow any more, turn the pump filter (③) open to the left.

3. Remove any foreign material from the pump filter (③). After cleaning, turn the pump filter (③) clockwise and insert the drain plug (②) to the original place. close the lower cover cap.

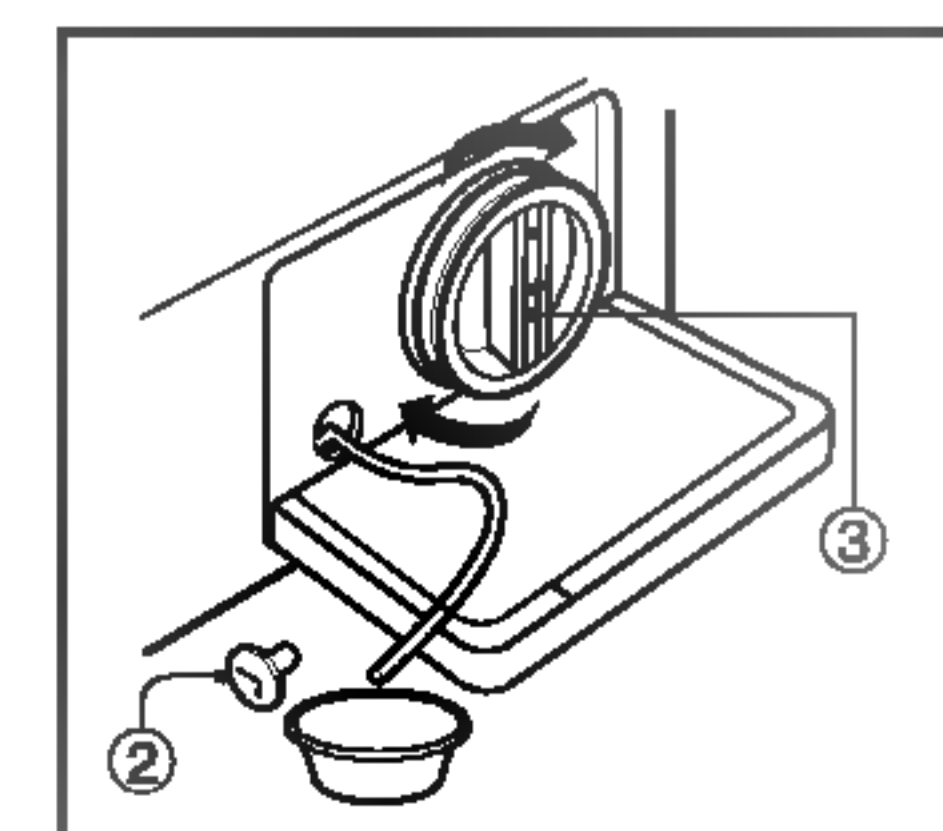
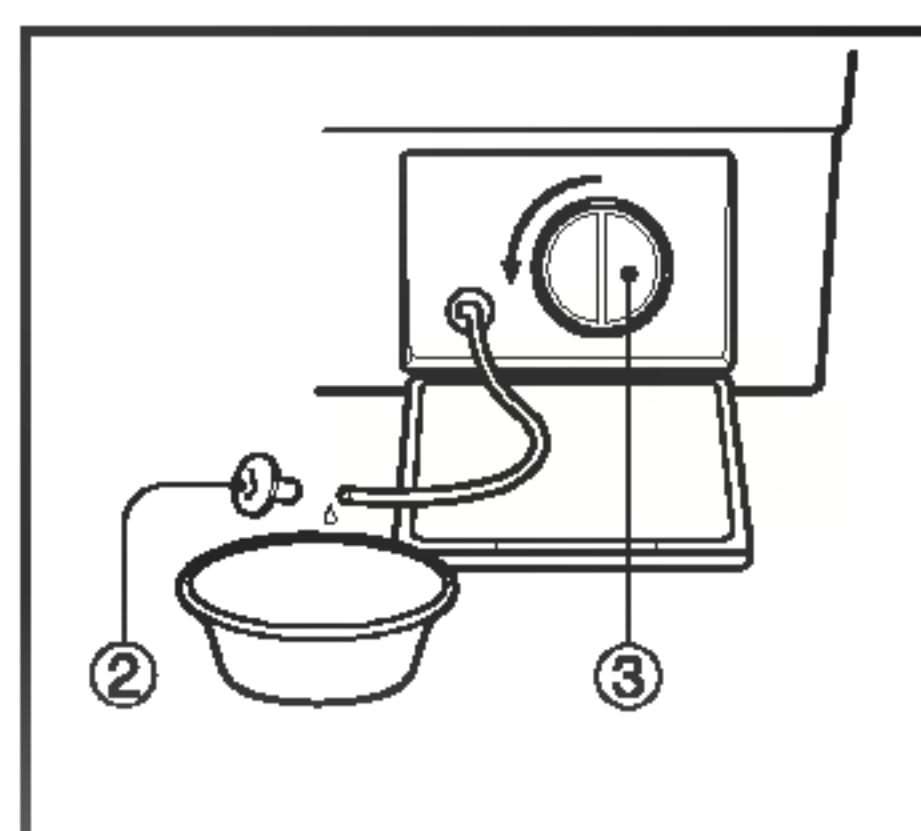
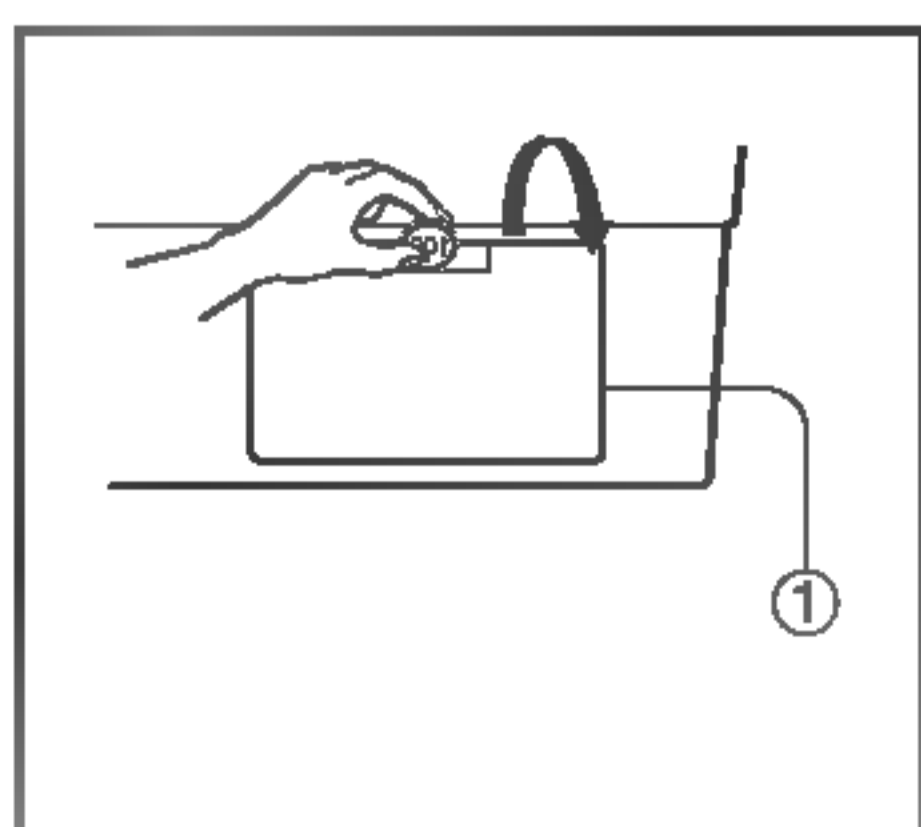

## DRAIN PUMP ASSEMBLY

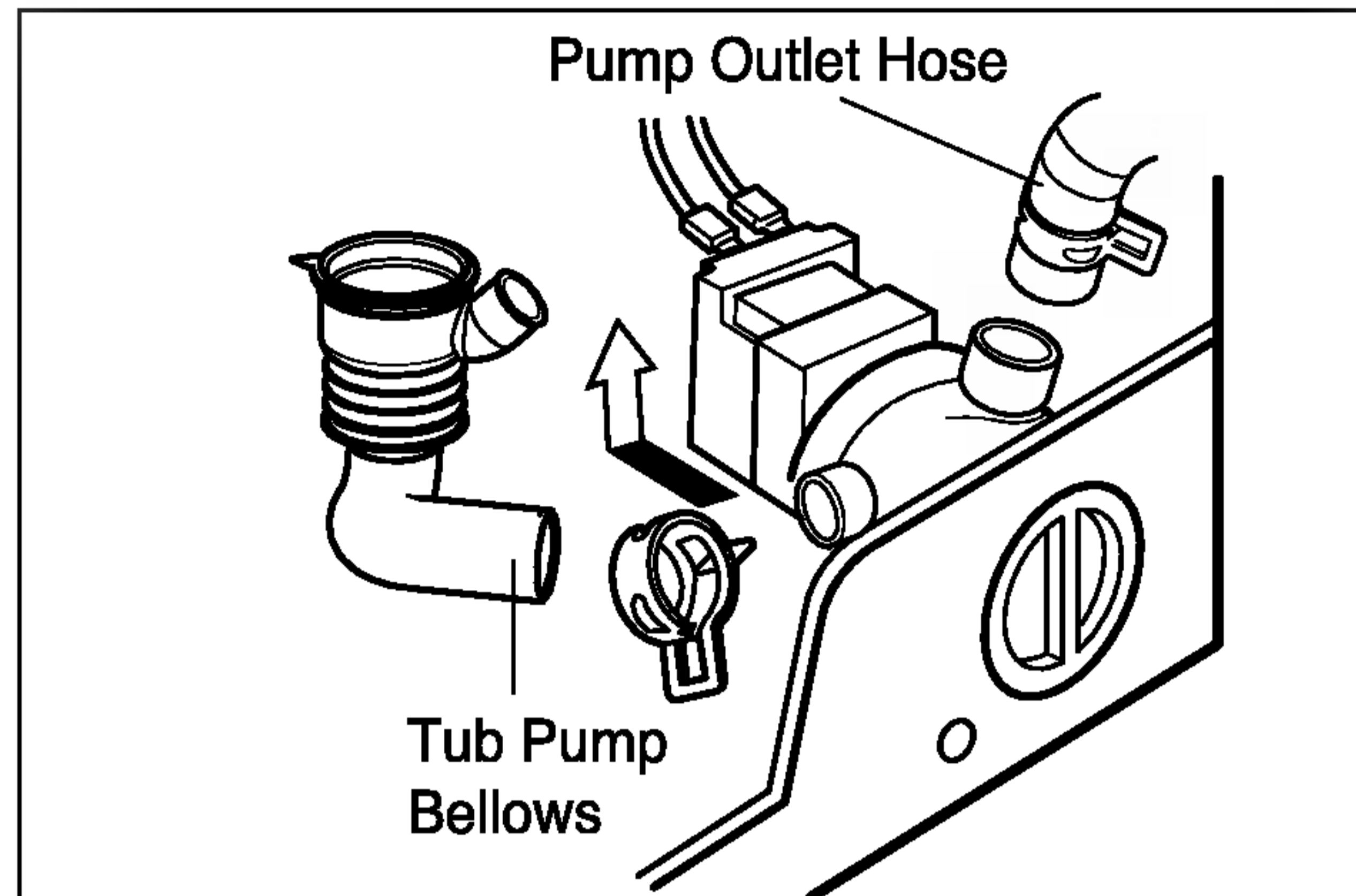

- ① Remove pump outlet hose.
- ② Remove tub pump bellows.
- ③ Remove cap (Remaining Hose.)
- ④ Disconnect the wiring.
- ⑤ Unscrew 2 screws.
- ⑥ Remove the pump.

## HEATER ASSEMBLY

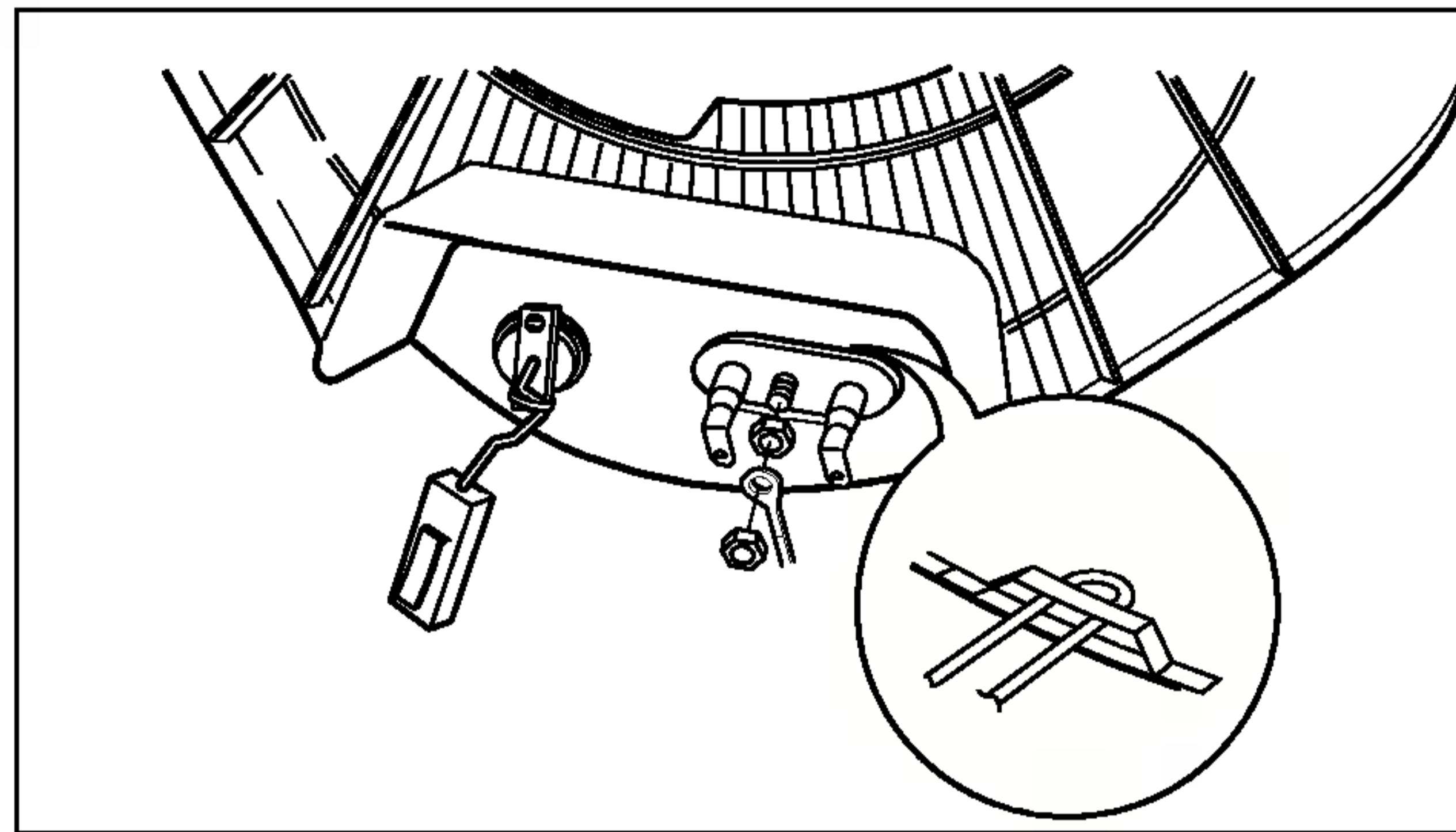

- ① Loosen the M6 heater nuts to pull out the HEATER ASSEMBLY.

When mounting the HEATER ASSEMBLY be sure to insert the HEATER ASSEMBLY into the heater clip on the bottom of the tub.

## THERMISTOR

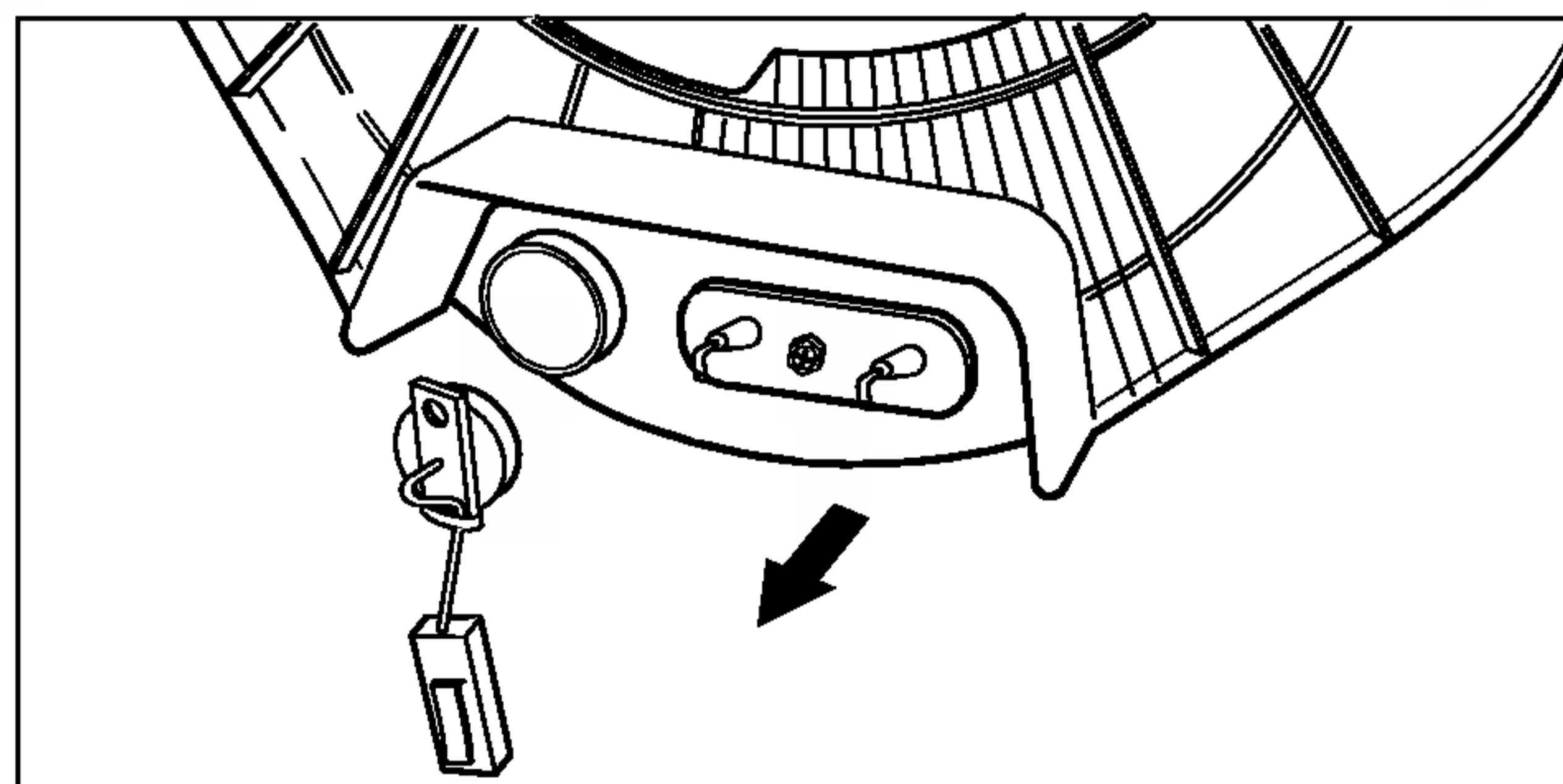

- ① Pull it out by holding the THERMISTOR bracket.  
If it is pulled by the wire, it may be broken.
- ② When mounting the THERMISTOR again, make sure that it is got back tight to the bushing.

## SWITCH ASSEMBLY, DOOR LOCK

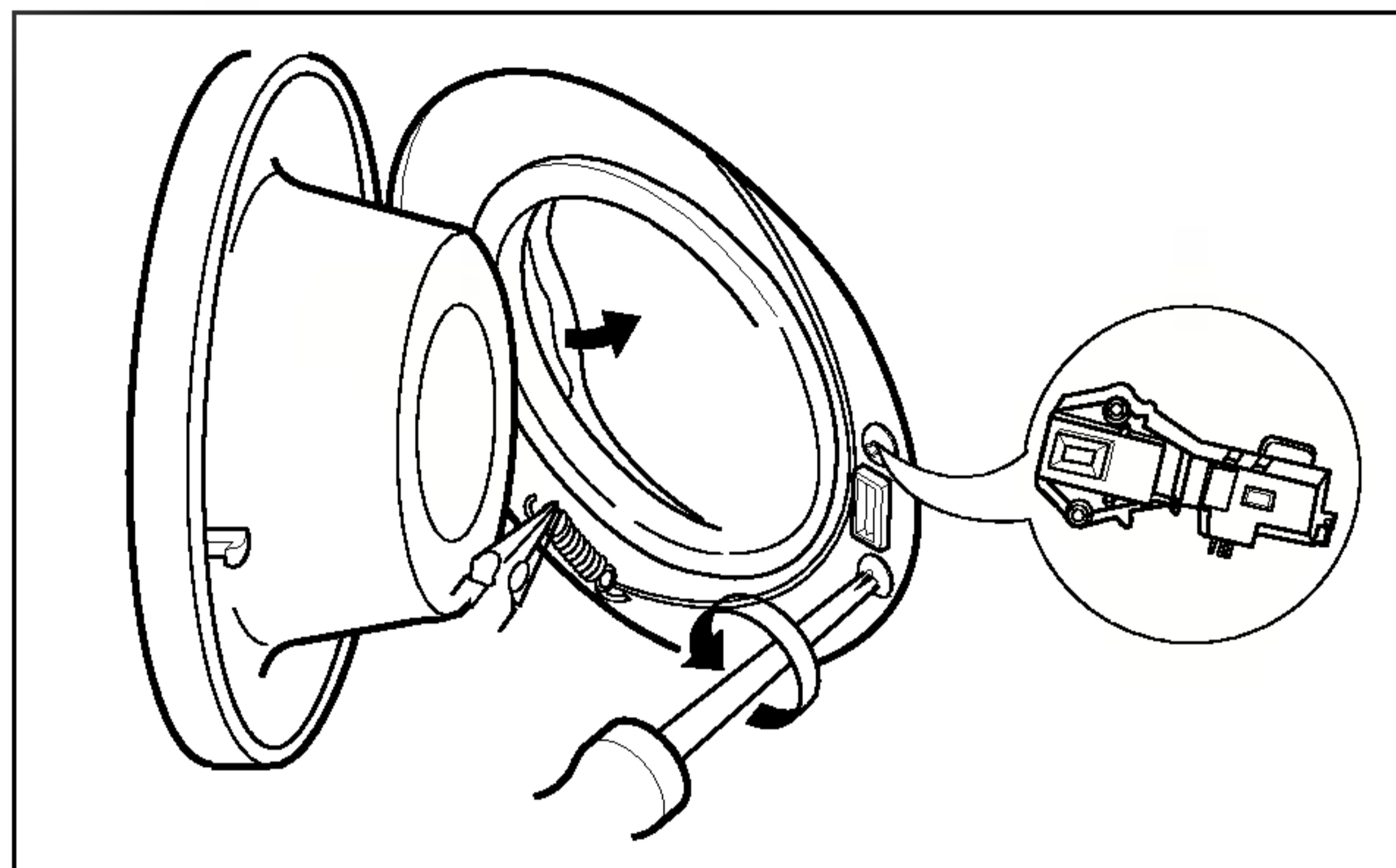

- ① Take apart the CLAMP ASSEMBLY (cabinet) and release the GASKET.
- ② Unscrew 2 screws holding the DOOR SWITCH ASSEMBLY.
- ③ Disconnect the door lock from the wiring connector.

## WHEN FOREIGN MATERIAL IS STUCK BETWEEN DRUM AND TUB

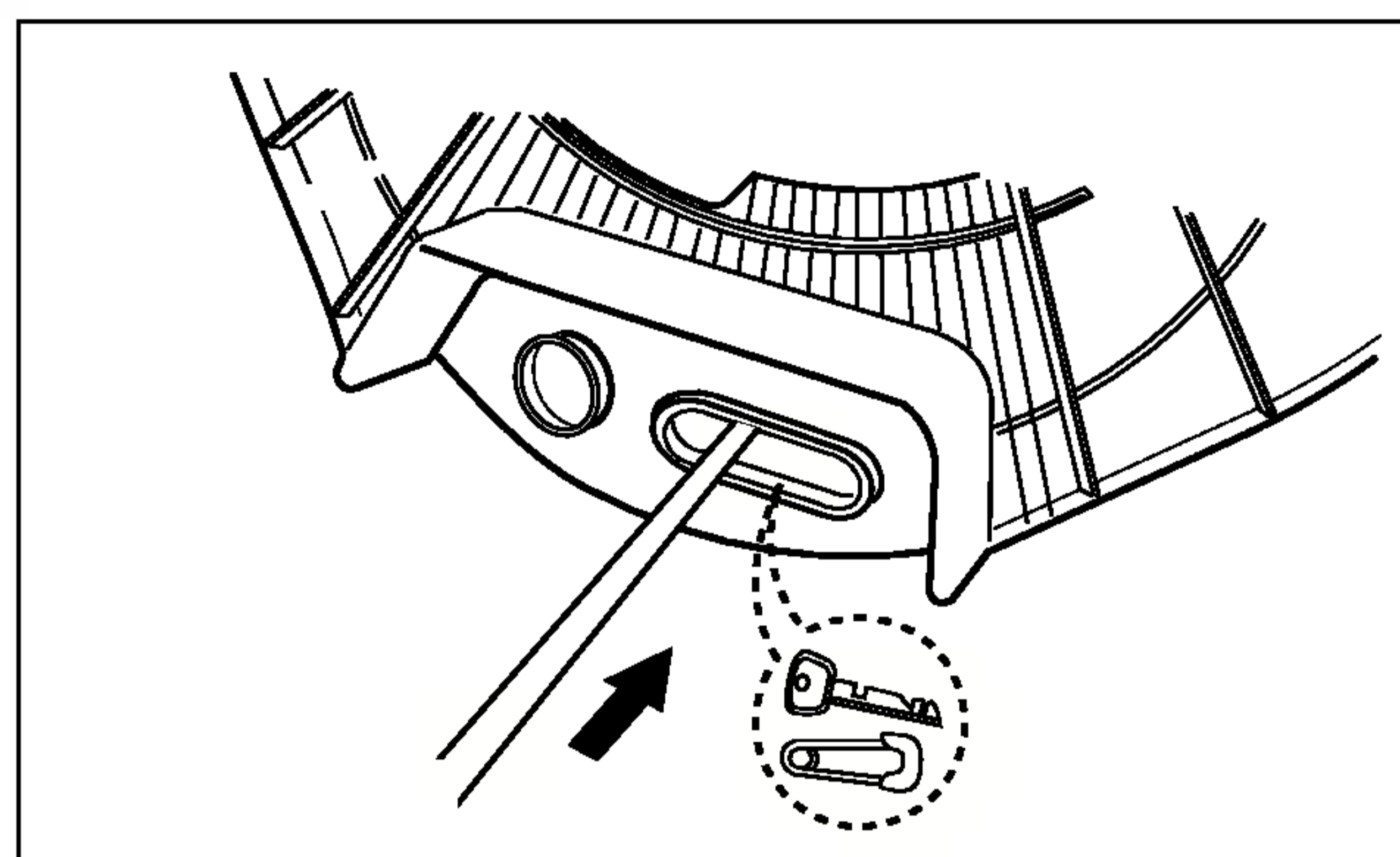

- ① Remove the HEATER ASSEMBLY.
- ② Remove the foreign material (wire, coin and others) by inserting a long bar through the hole.

# 10-1. THE PART LIST OF CABINET ASSEMBLY

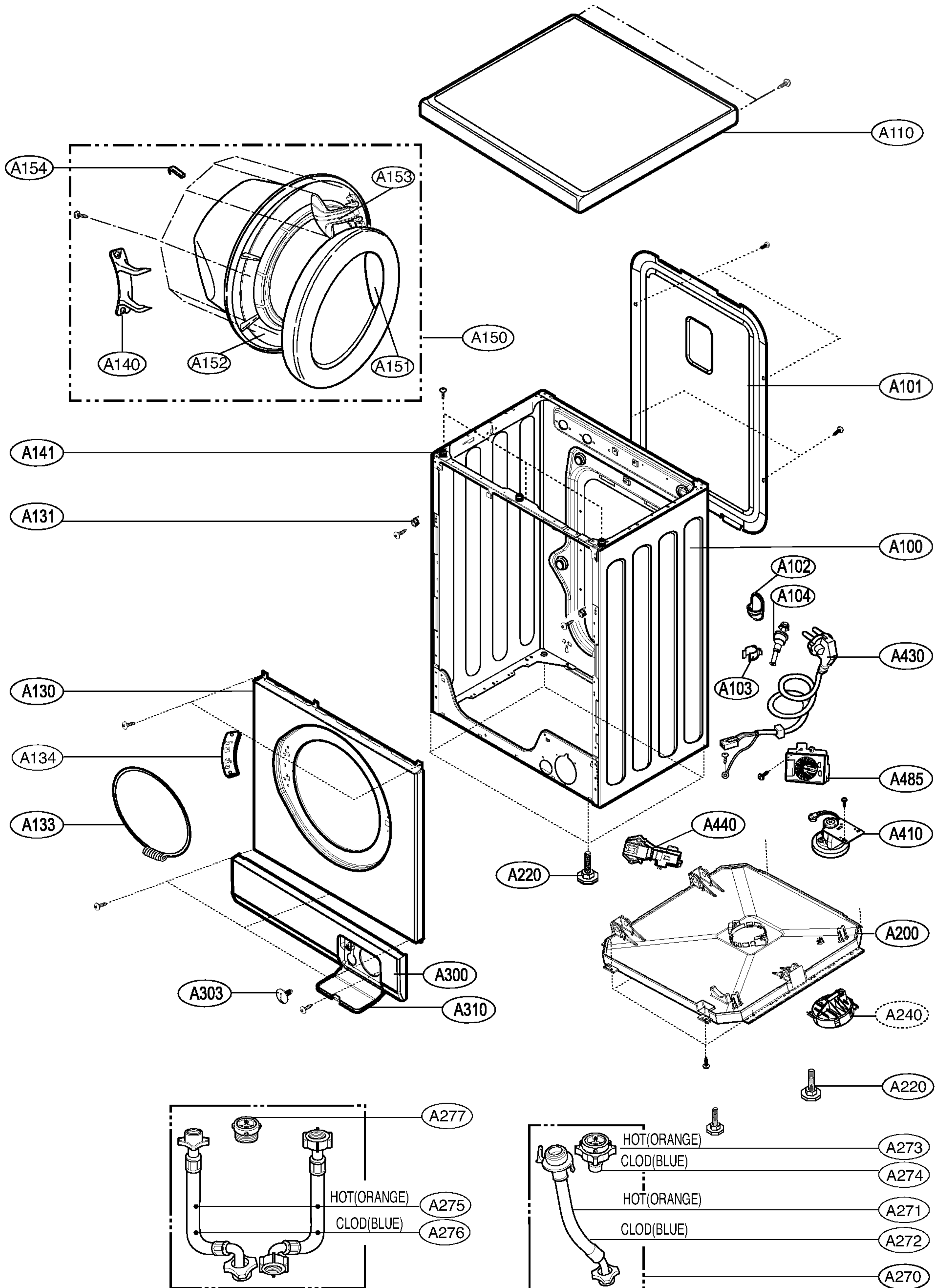



# 10-2. THE EXPLODED VIEW OF CONTROL PANEL & DISPENSER ASSEMBLY

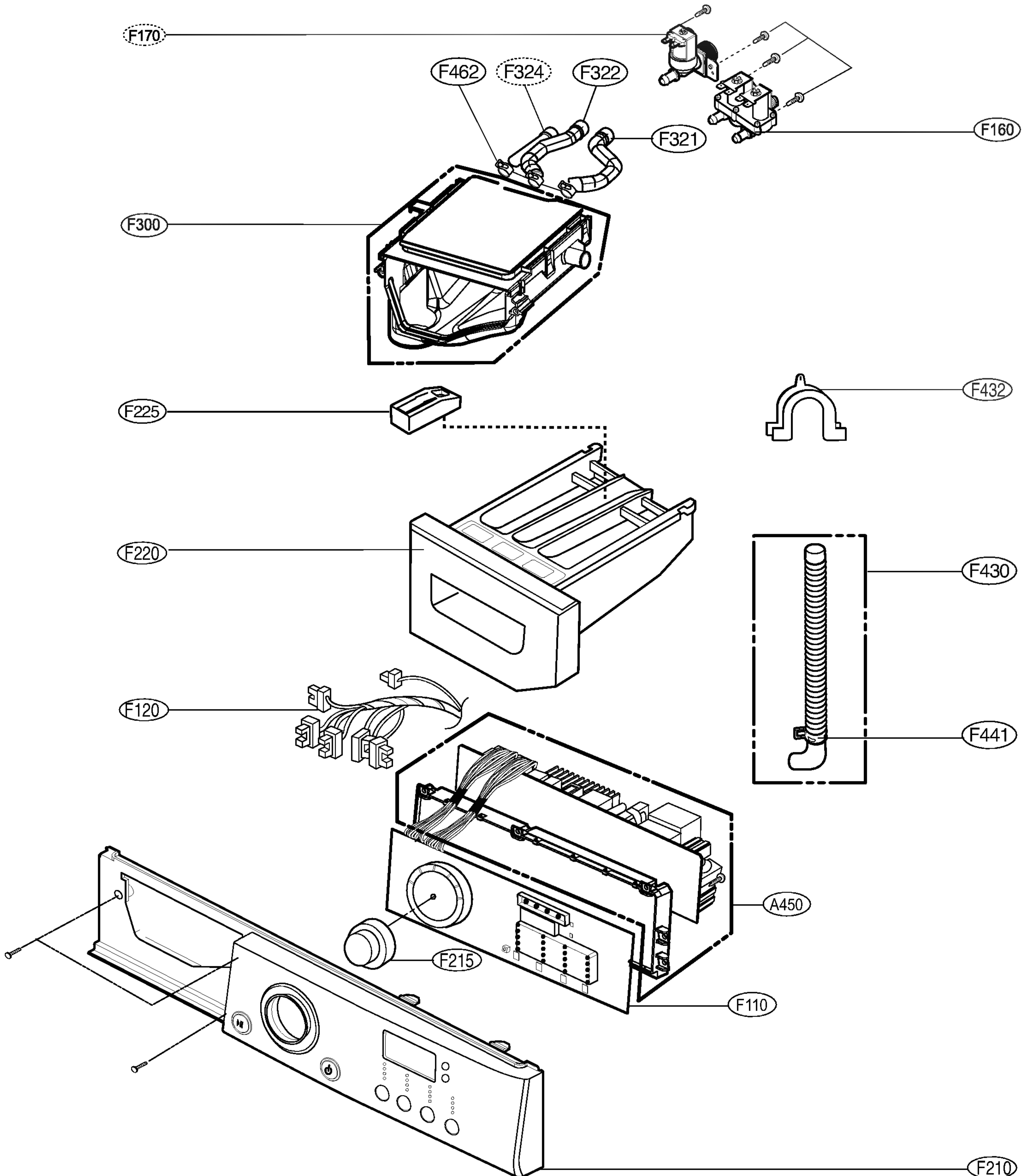

# 10-3 THE EXPLODED VIEW OF DRUM & TUB ASSEMBLY

