



# Operating Instructions

# Built in Oven

Please read this instruction manual carefully before using the oven. This will ensure that you know the important safety information and the correct operation of the oven.

Please keep this manual in a easily accessible place and refer to them anytime. Please transfer this manual to new owner if you sell the oven.

LB672098S

# Contents

---

<b>Safety</b> .....	4~8
<b>Appliance description</b> .....	9
<b>Control panel</b> .....	10~11
<b>Accessories</b> .....	12~15
<b>Runners</b> .....	16~17
Telescopic runners .....	16~17
Side runners.....	17
<b>Before using for the first time</b> .....	18~19
<b>Operating the oven</b> .....	20~21
Operating sequence .....	20
The timer .....	21
<b>Oven functions</b> .....	22~24
<b>Manual cook</b> .....	25~26
<b>Using the oven</b> .....	27~33
Changing the temperature .....	27
Enter the Duration .....	27
Changing the Duration .....	28
Cooling system.....	28
Residual Heat Indicator.....	28
Before starting the rotisserie function.....	29
Using the rotisserie .....	30
Rotisserie Table.....	31
Safety Lock .....	32
Energy efficiency.....	32
Safety cut-out.....	32
Rapid heat-up.....	33
<b>Speed Cook</b> .....	34
<b>Healthy Roast</b> .....	35~38
<b>Auto cook</b> .....	39
<b>My Recipe</b> .....	40~41
<b>e-Cookbook</b> .....	42~43
<b>Changing settings</b> .....	44~47
Language .....	44
Clock .....	44
Heating up phase.....	45
Oven lighting .....	45

Display .....	46
Sound.....	46
Default setting .....	47
Start.....	47
Temperature .....	47
Initial stage .....	47
<b>Speed autocook table.....</b>	<b>48~49</b>
<b>Auto cook table.....</b>	<b>50~73</b>
Fish .....	50~51
Meat .....	52~53
Pastry .....	54~55
Potato products .....	54~55
Poultry and game .....	56~59
Snacks .....	60~61
Pizza .....	60~61
International automatic recipes .....	62~73
<b>Baking .....</b>	<b>74~75</b>
<b>Baking table .....</b>	<b>76~80</b>
<b>Roasting .....</b>	<b>81~82</b>
<b>Roasting table .....</b>	<b>83</b>
<b>Grilling .....</b>	<b>84~85</b>
<b>Grilling table.....</b>	<b>85</b>
<b>Defrosting.....</b>	<b>86</b>
<b>Special functions .....</b>	<b>87</b>
<b>Cleaning and care .....</b>	<b>88</b>
<b>Pyrolytic cleaning .....</b>	<b>89</b>
<b>Oven light .....</b>	<b>90</b>
<b>Oven door.....</b>	<b>91~95</b>
<b>Troubleshooting .....</b>	<b>96~97</b>
<b>Error codes.....</b>	<b>98</b>
<b>Technical specifications.....</b>	<b>99~100</b>
<b>Installation instructions .....</b>	<b>101</b>
<b>Customer service &amp; spare parts.....</b>	<b>102</b>
<b>Warranty ..</b>	<b>103</b>

# Safety

---

- This oven must only be installed by a licensed electrician.
- The installer is responsible for the correct electrical connection of the appliances and the observance of the relative safety recommendations.

## Electrical Safety

If the oven has been damaged in transport, do not connect it.

- This appliance must be connected to the mains power supply by a **specially licensed electrician** only.
- In the event of a fault or damage to the appliance, do not attempt to operate it.
- Repairs of the appliance should be carried out by a **licensed technician** only. Wrong repairs may result in considerable danger. If you need repairs, contact an LG Service Center or your dealer
- If the supply cord is damaged, it must be replaced by the manufacturer, its service agent or similarly qualified persons in order to avoid a hazard.
- Electrical leads and cables should not be allowed to touch the oven.
- The oven should be connected to the electricity supply by means of a proper circuit breaker or fuse.  
Never use multiple plug adapters or extension leads.

- 
- Rating plate is located on the left side of door and on the back cover.
  - The power supply of the appliance should be turned off when it is being repaired or cleaned.
  - Be careful in connecting electrical appliances to sockets near to this appliance.
  - This connection may be achieved by having the plug accessible or by incorporation a switch in the fixed wiring in accordance with the wiring rules.
  - Do not use harsh abrasive cleaners or sharp metal scrapers to clean the oven door glass since they can scratch the surface, which may result in shattering of the glass.

**⚠ Warning:** The appliance should be powered down before replacing the lamp to avoid the possibility of electric shock.

**⚠ Warning:** When the oven operates, the interior parts will be very hot.

**⚠ Warning:** Accessible parts may become hot during use. Young children should be kept away.

**⚠ Warning:** Accessible parts may become hot when the grill is in use. Children should be kept away.

**⚠ Warning:** Please ensure cooking times are correctly set as over cooking may result in the food catching fire and subsequent damage to your oven.

# Safety

---

## Safety during Operation

- This oven has been designed only for the cooking of household foods.
- When in use, the oven interior surfaces become very hot! Care should be taken to avoid touching heating elements inside the oven.
- Never store flammable or easily deformable materials in the oven.
- The oven surfaces will become hot when the appliance is operated at a high temperature for a long period of time.
- Excess spillage should be removed before self cleaning and all utensils should not be left in the oven during pyrolytic self-cleaning.
- During self cleaning the surfaces get hotter than usual and children should be kept at a safe distance.
- When cooking, take care when opening the oven door as hot air and steam will escape rapidly.
- When cooking dishes that contain alcohol, the alcohol can evaporate due to the high temperatures. The vapour can catch fire if it comes into contact with a hot oven part.
- Do not use high-pressure water cleaners or steam jet cleaners for electrical safety reasons.

- 
- Children should be kept at a safe distance when the oven operates.
  - Frozen foods such as pizzas should be cooked on the wire grill. If the Baking tray is used, it may become deformed due to the great difference in temperature.
  - Don't pour water into the oven bottom when it is hot. This could cause damage to the enamel surfaces.
  - The oven door must be closed when cooking is performing.
  - Don't spread aluminium foil on the bottom of the oven and do not place any baking trays or tins on it. The aluminium foil blocks the heat, which may result in damage to the enamel surfaces and cause poor cooking results.
  - Dripping fruit juices from the baking tray will leave stains, which become indelible. When cooking very moist cakes, use the deep pan.
  - Do not use the oven door as a rest table for hot or cold cookwares.
  - The appliance is not intended for use by young children or infirm persons without supervision.
  - Children should be kept at a safe distance until the oven has cooled down after cooking.

# Safety

---

## Disposal

### Packaging material

- Your new oven has been correctly packaged for transportation. Remove all of the packaging material before putting the appliance into use.
- The packaging material can be completely recycled. You can obtain addresses for environmentally-friendly disposal operations from your local authority.

## Used appliances

### Warning

- Used appliances must be rendered unusable prior to disposal so that they no longer present a risk. To achieve this, disconnect from the mains supply and remove the power supply cable.

### **For the protection of the environment, used appliances must be disposed of properly.**

- The appliance must not be disposed of along with normal domestic waste.
- Your local authority will inform you of times for uplifting special waste or identify public disposal facilities for you.



# Appliance description

## Overview

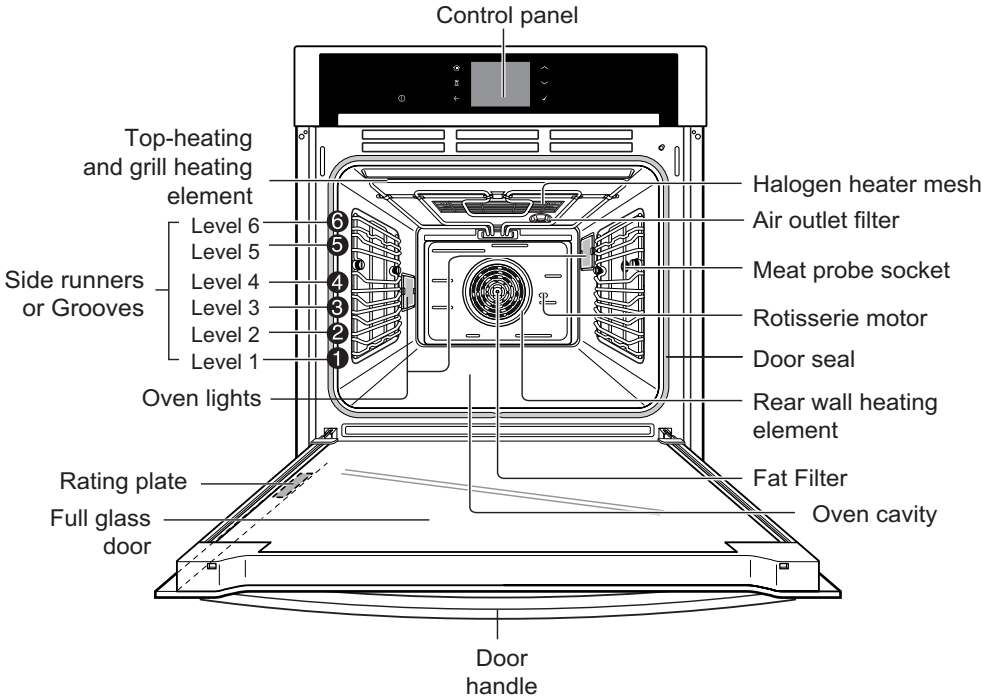

Oven levels are numbered from the bottom up.  
The 5 and 6 levels are mainly used for grill functions.

The cooking tables throughout this operating instructions give you suggested oven level, however you can change these to suit yourself.

Note : Rating plate can be located at left-hand inner edge of the door or front-side of the oven.

# Control panel

---

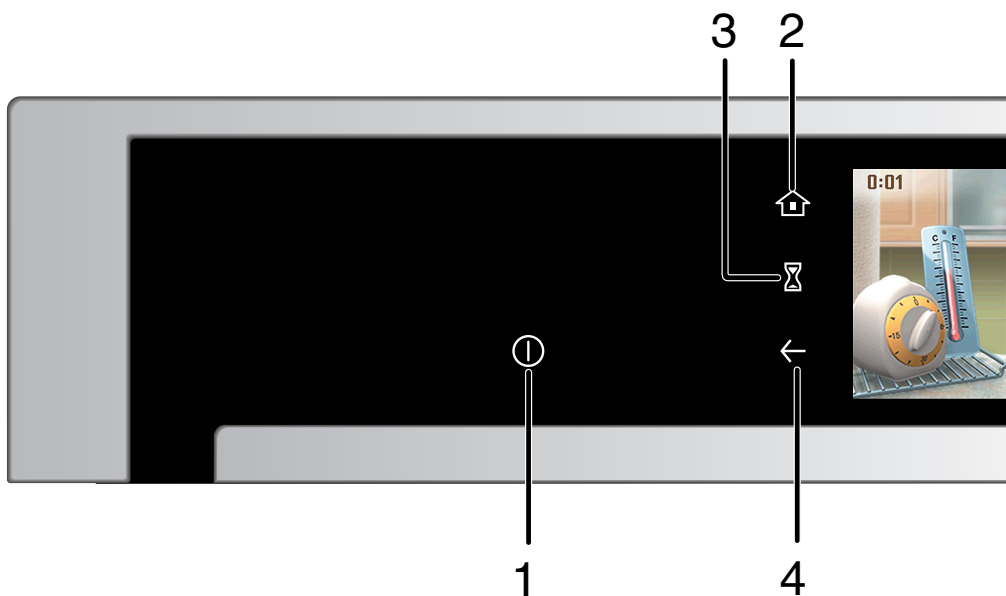

1. Power key
2. Home key
3. Timer key
4. Back space key

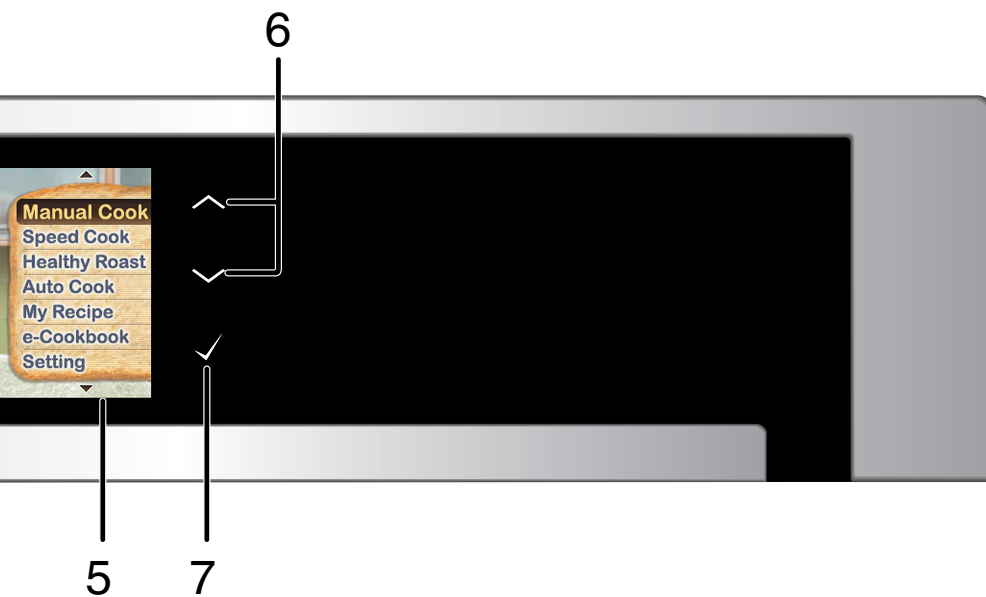

- 5. Display(TFT Color LCD)
- 6. Up & Down key
- 7. Enter(OK or Yes) key

# Accessories

---

## Wire grill

For dishes, baking tins, grilling and roasting tins.

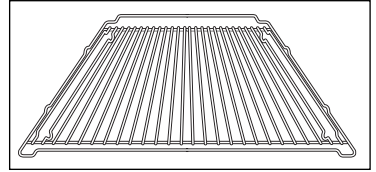

## Baking tray

For cakes, sponges and biscuits.

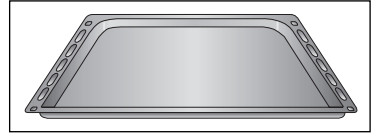

## Deep pan

For moist cakes, for roasting and for catching roasting juices or fat.

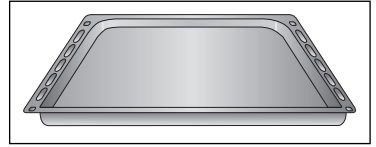

### Tip :

When using the tray and wire grill with groove type oven for the first time, smear the groove with cooking oil, using a cloth. Then wipe the groove with a dry cloth. Now you can use them more smoothly.

## Grill tray

For grilling meat, to be placed on top of the deep pan. Dripping fat is caught in the deep pan.

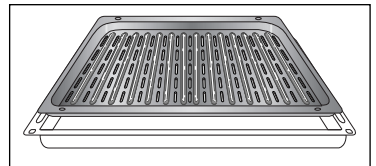

---

## **Fat filter (Optional)**

For protecting the fan against fat building up.  
The filter may be in place when the fan is used  
for roasting.

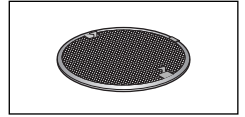

### **Note:**

To install the fat filter, insert the two hooks  
Into the holes on the fan cover as  
illustrated.

The fat filter must cover the fan venting  
holes completely. Do not use the fat filter  
In baking mode, as it restricts the air flow.

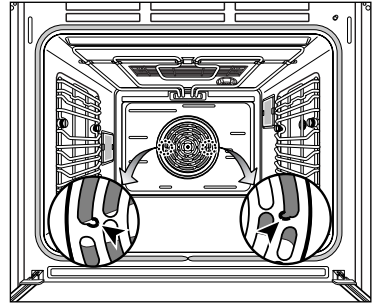

# Accessories

## Tips on using the trays and wire grills

Ensure that the trays and wire grills are properly fitted onto the two side oven levels.

Take particular care when removing finished dishes and meals from the oven!

Use a suitable cloth pot holder or oven gloves.

If you are using the grill tray in combination with the deep pan or some other tray to catch dripping liquids or fat, then do not put the trays down on the bottom of the oven, slide them into the lower levels.

If you place trays on the oven floor, the resulting build-up of heat can damage the surface of the oven. For this reason, there must always be a minimum gap of 2 cm between the accessories and the oven floor.

## Fitting the wire grill, baking tray and deep pan

Slide the tray or wire grill in at the desired level.

The oven levels are numbered from the bottom up to the top.

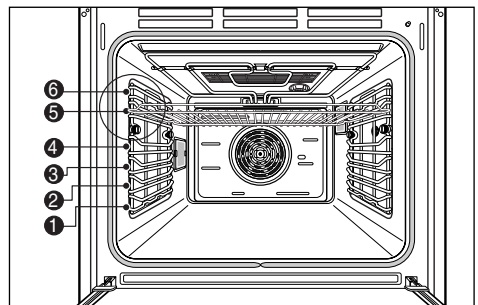
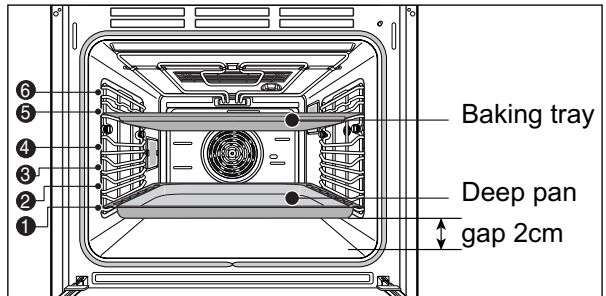

---

## Meat probe

The electronic meat probe enables the meat temperature to be monitored while cooking and to assist in giving good cooking results each time it is used.

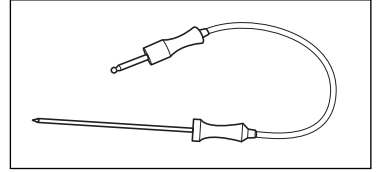

## Rotisserie

For grilling thicker items such as stuffed meat, poultry and kebabs. The rotisserie motor turns the spit to grill food evenly from all sides. Food does not need to be manually turned when using the rotisserie.

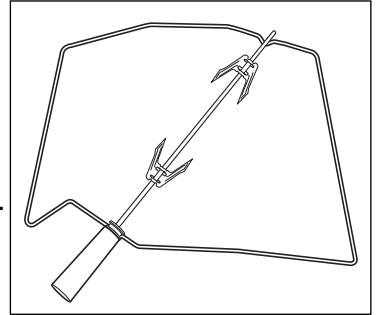

## Note :

Before using the rotisserie for the first time, it should be cleaned with hot water and a little washing up liquid.

# Runners

## Attaching the telescopic runners (Optional)

When purchasing for the first time, attach the telescopic runners as following procedures.

1. Place the U-form of the telescopic runner between the two screw holes as illustrated.

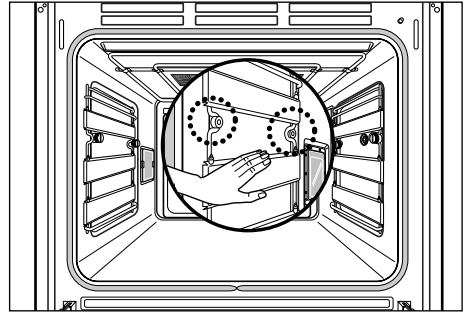

2. Insert and fasten the two screws.

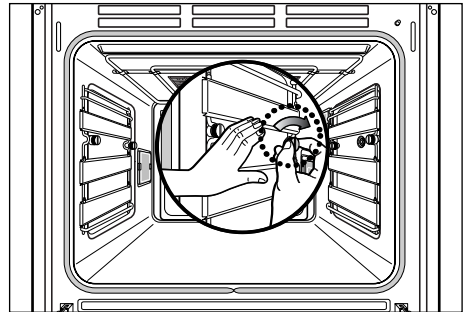

3. Attach the other telescopic runner in the same way.



4. Baking tray and Wire grill should be positioned accurately on the hook of telescopic runners. An unstable coupling between the baking tray and the telescopic runners may cause the trays to drop or food to fall onto the oven floor.

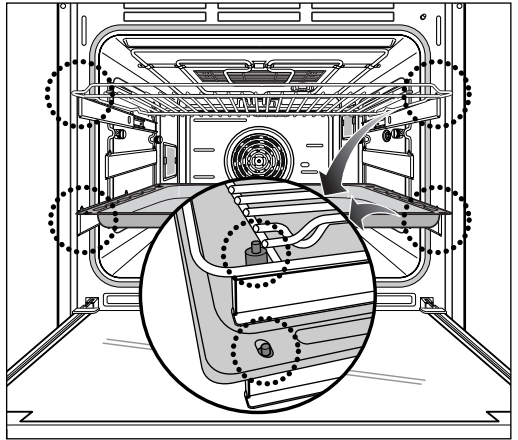

## Attaching the side runners

**When using the oven for the first time, attach the side runners. The attaching procedure are the same as telescopic runners. You can find the side runners in the accessory box.**

**⚠ Warning:** You should not do self-cleaning with these telescopic runners and other all accessories in the oven. Because this self-cleaning is performed in high temperature (about 500°C), the telescopic runners and utensils may be distorted and become unuseable.

# Before using for the first time

When the oven is connected to the electrical supply, it will switch on automatically and LG logo will appear in the display.



The language settings menu will then appear in the display.



- 1 Press the **Up(^)** or **Down(v)** key until the language you want is highlighted in the display.
- 2 Press the **Enter key(✓)** to confirm your selection.

After selecting the language you can set the clock.

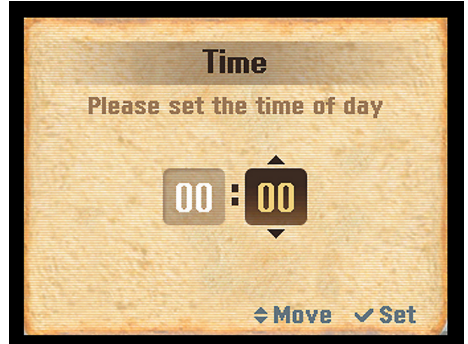

When the oven is first switched on the clock will show 00:00 until you have set the correct time. Set the clock using the **Up(^)** and **Down(v)** key and **Enter(✓)** keys.

See “Changing settings - Clock” for details. The Main menu will then appear in the display. The factory default setting for the clock is 24h.

**Tip :** When you set the clock or temperature if you press and hold the **Up(^)** or **Down(v)** key by about 2 seconds, the hours and minutes can be changed more easily.

The oven is now ready for use.

---

## Initial cleaning

Clean the oven carefully before using it for the first time.

**Important** : Do not use any caustic or abrasive cleaners. These can damage the oven surfaces.

### Appliance front



The oven with a metal front must be cleaned with standard detergents only. Wipe the front of the appliance with a slightly damp cloth.

### Oven interior

1. Take all accessories out of the oven and wash them with warm water and dishwashing liquid.
2. Clean the oven interior in the same way, using warm water and dishwashing liquid.
3. Allow the oven to dry.

## Heating up

Before baking or roasting for the first time, the oven should be turned on and allowed to heat up(200~250°C) with nothing in it. Then allow the oven cool down to room temperature. New ovens have a unpleasant odours. Open the window and ensure there is adequate ventilation during this period.

1. Ensure that the time of day is set correctly.
2. Remove all accessories from the oven.
3. Use **Convection heat**() , or **Fan grill**() functions to heat the oven up.
4. Leave the oven on for at least one hour.

# Operating the oven

## Operating sequence

The Main menu will appear in the display after switching the oven on by pressing the **Power** (Ⓟ) key.

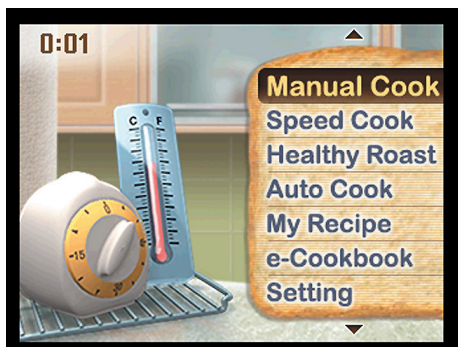

Seven menus will appear in the display. They can be selected directly.

If you select the one of the menus, e.g. Setting, you will be taken to the next step.



The scroll bar indicates that there are further options. You can see them by pressing the **Up**(^) or **Down**(v) key.

If you select an option e.g. Clock, you will be taken to the next step within that option.



You can now select the option you want. Press the **Enter**(✓) key to confirm your choice.

- **Back space key** (←)  
You can return to the previous menu by pressing the Back key.
- **Home key** (🏠)  
If you want to return to the Main menu directly, press the Home key.

## The timer

The timer can be used to time any activity in the kitchen e.g. boiling eggs.

You can enter a time up to 9hours 59minutes

### ❑ Using the timer

Press the **Timer**( ⏰ ) key. A pop up window will appear in the display.



- 1 Press **Up**( ^ ) or **Down**( v ) key until the time you want appear in the display and then press the **Enter**( ✓ ) key.

The time set for the Timer begins to count down in upper-left of the display.

You will hear a signal tone at the end of the set time.

### ❑ Canceling the timer function

Press the **Timer**( ⏰ ) key. The pop up window for the Timer will appear in the display.



- 1 Press the **Timer**( ⏰ ) key once to set the time to "0:00".
- 2 Press the **Enter**( ✓ ) key.

You can use the Timer function at any time without operating any cooking functions.

# Oven functions

## Convection heat

Convection heat uses only the rear wall heating element and the fan situated on the back wall of the oven.

It is possible to bake on more than one level in Convection heat. This means that it is suitable for fruit cakes and stirred cake or yeast-dough, for example a bread plait.

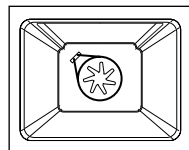

## Hot air

In addition to the Conventional heat elements, Hot air uses the fan in the back of the oven. This means that the roasting and baking temperature can be reduced by 20~40°C. This mode is suitable for cakes and biscuits, as it is possible to bake on more than one level at the same time.

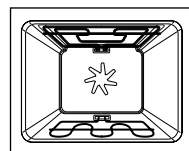

## Fan grill

In this operating mode, the grill element and the fan on the rear wall are on. This function is suitable for pizzas, quiche lorraine or cheesecakes. Grill with the oven door closed.

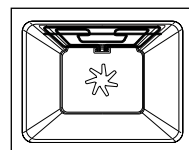

## Conventional heat

For Conventional heat, the heating elements above and below the oven cavity are used. This operating mode is suitable for baking cakes, baking with a short baking time, sensitive doughs and for roast beef and fillet of beef on the one level.

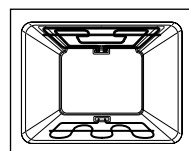

## Bottom heat

In bottom mode, only the heating element in the oven floor is used. This function is particularly suitable for finishing off cakes or pizzas on one of the lower oven levels.

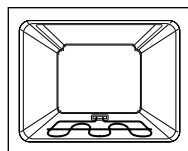

## Large grill (1, 2, 3)

The Large grill uses the entire top heating element. No specific temperature can be set. You can choose between three settings. The Large grill is suitable for cooking steaks, cutlets, fish or making toast, and for browning when cooking larger dishes with a Gratin topping.

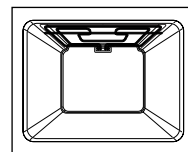

## Small grill (1, 2, 3)

The Small grill operates in the same way as the Large grill, however, only inner part of the top heating element is used. This makes it suitable for smaller dishes.

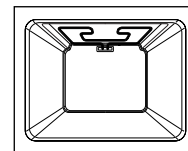

## Defrost

In defrost mode, the fan is used without heating. The circulating air speeds up the defrosting process. Place the frozen food in a suitable container to trap the liquid produced during defrosting. Where appropriate, you can use the wire grill and the deep pan to avoid soiling the oven. If water is allowed to run out into the oven, the door seals will be contaminated and an unpleasant odour may result.

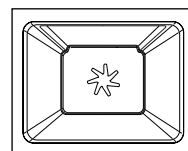

# Oven functions

---

## Warm dishes

This system use a heating element located around the fan at the back of the oven and the circulation of heated air. It is ideal for keep dishes warm evenly.

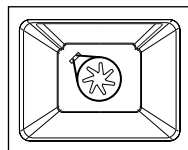

## Keep warm

Heat from the top and bottom elements are used to maintain a temperature of 75°C. You can use this function for keeping food warm until ready to serve.

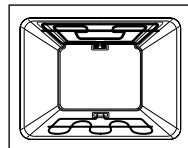

## Pyrolytic cleaning

Traces of food are burned up by the high temperature and can be easily wiped after the cleaning process. For your safety, during Pyrolytic cleaning the oven door is locked shut. The lock is only released once the temperature falls below 240°C after this mode has been switched off. For Pyrolytic cleaning, you have a three programmes of different length!

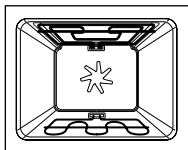

P1 : approx. 75 min

P2 : approx. 95 min

P3 : approx. 120 min

Take care, as surfaces become very hot during Pyrolytic cleaning. Keep children at a distance. Do not pour water into the hot oven. The sudden generation of steam can cause burns or damage to the oven. Do not wipe the oven until it has cooled down to a safe level.

**IMPORTANT :** If you have started the pyrolytic cleaning with the meat probe inserted into the socket, the heating elements will not be operated and the fan will be operated only for safety reasons.



# Manual cook

## Setting the functions

You first have to switch the oven on by pressing the **Power** (ⓐ) **key**. The Main menu will then appear in the display.

Select the “Manual Cook” and confirm the choice by pressing the **Enter**(✓) **key**.



## Selecting an oven function

You can select any of the functions in the display by simply highlighting the one you want and confirming your selection.

**Proceed as follows :**

- 1 Press the **Up**(^) or **Down**(v) **key** until the function you want is highlighted in the display.
- 2 Press the **Enter**(✓) **key** to confirm your selection.

## Setting a temperature

Each cooking function has been given a pre-set temperature to make it easier. You can either accept it or change it to suit your recipe.

If you select a function e.g. Convection heat, you will be taken to the setting display.

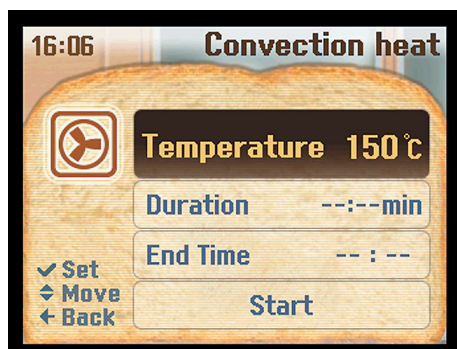

Press the **Enter** **key**(✓) to change the temperature. The triangle symbols will appear next to the pre-set temperature. You can now change the recommended temperature to suit your preferences using the **Up**(^) or **Down**(v) **key** then press the **OK**(✓) **key** to confirm your selection.

Duration and End Time can also be entered but are not required for cooking to commence.

# Manual cook

## Pre-set temperature

The following temperatures are set at the factory :

Function	Pre-set temperature	Temperature range	Heating element / fan
Convection heat	150°C	40°C - 300°C	Convection heater, fan
Hot air	160°C	40°C - 300°C	Top heater, Bottom heater, fan
Fan grill	190°C	40°C - 300°C	Top heater, fan
Conventional heat	190°C	40°C - 300°C	Top heater, Bottom heater
Bottom heat	170°C	40°C - 300°C	Bottom heater
Warm dishes	65°C	40°C - 100°C	Convection heater, fan
Keep warm	75°C	40°C - 100°C	Top heater, Bottom heater

For the Large grill, Small grill and Pyrolytic cleaning, you can use any of three settings by selecting the one you want and confirming your choice without temperature setting. If you select the Defrost, you can set the Duration and End time only.

Each function can be used with the following elements.

- Large grill : Inner heater, Outer heater
- Small grill : Inner heater
- Pyrolytic cleaning : Top heater, Bottom heater, fan
- Defrost : fan

# Using the oven

---

## Changing the temperature

If you want to change the temperature after a cooking programme has been started, press the **Enter(✓)** key to call up the setting display again. Press the **Enter(✓)** key a second time to prompt the temperature display, and then use the **Up(∧)** or **Down(∨)** keys to change the temperature. Cooking will then recommence 5 seconds after the last key press at the new temperature.

## Enter the Duration

You can set the Duration and End Time to switch a cooking programme off, or on and off automatically. If you select a function e.g. Convection heat, you can now set the cooking duration using the **Up(∧)**, **Down(∨)** and **Enter(✓)** key.

## Duration

You can enter the duration of a cooking programme. Once the time set has elapsed, the oven will switch itself off automatically.

## End Time

You can specify the time at which you want cooking to end. The oven will be switched off automatically at the time you want.

To switch a programme off automatically

- You can either enter the Duration or just the End Time.

To switch a programme on and off automatically

- Enter the Duration and End Time.

The time which has not been entered is calculated automatically.

The Start time will be shown in the display up until the heating elements are switched on.

# Using the oven

---

## Changing the Duration

You can change the times entered for a cooking programme at any time.

- 1** Call up the setting display by pressing the **Enter(✓)** key.
- 2** Use the **Up(∧)**, **Down(∨)** keys to select the duration, then press the **Enter(✓)** key, then use the **Up(∧)** or **Down(∨)** keys to make the changes. The changes will apply automatically after 5 seconds.
- 3** Press the **Back space(←)** key to return to the previous display.

**Tip :** When you set the temperature if you press and hold the **Up(∧)** or **Down(∨)** key by about 2 seconds, you can reach the temperature you want more quickly.

**Note :** During cooking, baking or roasting, If you leave the door open for more than 10 minutes, all settings are cancelled.

## Cooling system

The cooling fan switches on automatically to keep the appliance's surfaces cool. The air is displaced from in between the oven door and the control panel. When the oven is switched off, the cooling fan runs on and only switches off once the appliance has cooled down. The fan speed will be higher during the pyrolytic cleaning.

## Residual Heat Indicator

When the oven is on the residual heat is indicated on the display until the temperature has gone down to 60°C.

Rotisserie is ideal for grilling thicker items such as stuffed meat, poultry, kebabs. The rotisserie can be used with Fan grill, Large grill, and Small grill functions.

## Before starting the rotisserie function

1. Place the deep pan at level 1 to collect the cooking juices. Then place the fat filter on the back wall. If vegetables and potatoes are placed around the edge of the deep pan, they will be roasted at the same time.

2. Secure the meat to the rotisserie spit using the clamps. Make sure the meat is balanced in the middle to give even rotation.

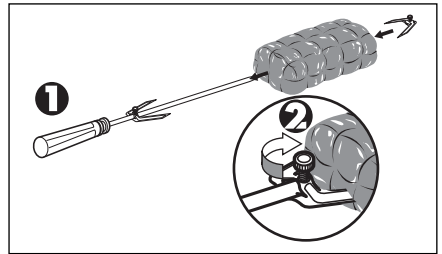

3. Place the cradle on the level 3 and position with the “U” shape at the front.

4. Reset the spit onto the cradle with the pointed end towards the back and gently push until the tip of the spit enters the turning mechanism at the back of the oven. Then lay the other end onto the “U” shape holder.

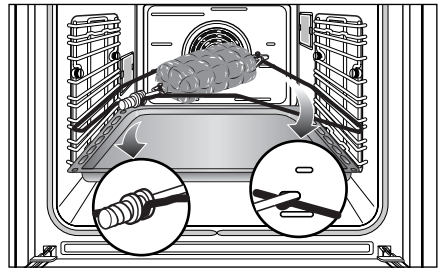

**Note :** The rotisserie skewer handle must be removed before closing the door. It can be reattached at the end of the cooking period to help remove the loaded skewer.

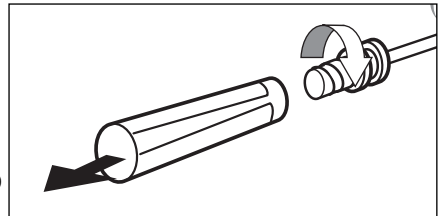

# Using the oven

## Using the rotisserie

You can use Fan grill, Large grill and Small grill functions for the rotisserie. If you select one of the functions, e.g. Fan grill the following will be shown in the display.

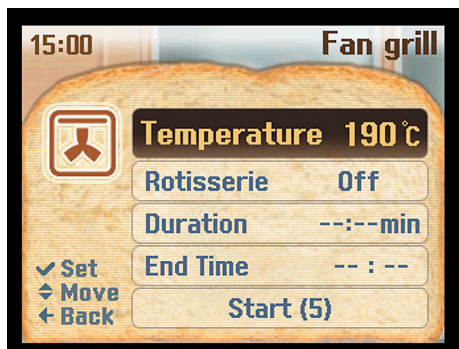

- 1 Change the recommended temperature if necessary.
- 2 Enter a Duration if necessary.
- 3 Press the **Up**( $\wedge$ ) or **Down**( $\vee$ ) **key** until “Rotisserie” is highlighted in the display.
- 4 Select either “On” or “Off”.
- 5 Select and confirm the word “Start”.

You can use the rotisserie function even after starting a cooking programme.

- 1 Press the **Enter**( $\checkmark$ ) **key** to adjust the settings.

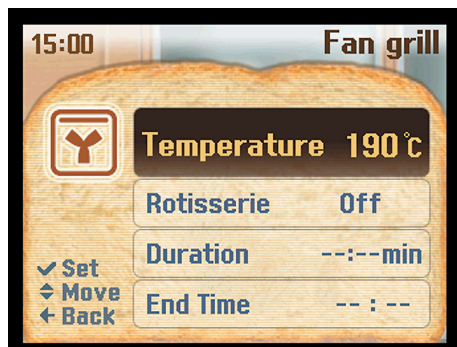

- 2 Change the rotisserie option.
- 3 Press the **Back space**( $\leftarrow$ ) **key** to return to the cooking display.

If there is no changes for about 5 seconds, the display will return to the previous display.

**Note** : Clean the rotisserie skewer in a solution of hot water and a little washing up liquid. If necessary a not-abrasive proprietary stainless steel cleaner may be used.

## Rotisserie Table

Type of meat	Weight of meat	Temperature (Fan Grill)	Cooking time
<b>Poultry</b>			
Small chicken	1.1 kg	240 °C	30 ~ 40 mins
Medium chicken	1.3 kg	240 °C	45 ~ 60 mins
Large chicken	1.8 kg	240 °C	60 ~ 70 mins
Marinated chicken portions	700 g	240 °C	15 ~ 20 mins
Chicken leg, Chicken breast	385 g	240 °C	15 ~ 20 mins
Baby chicken	450 g	240 °C	30 ~ 35 mins
Duck (medium bird)	1.6 kg	240 °C	60 mins
<b>Beef</b>			
Topside, small joint	0.7 kg	220 °C	Rare 30~40 mins Medium 45~60 mins Well done 60~70 mins
<b>Lamb</b>			
Rolled, boned leg	1.3 kg	200 °C	Medium 50~60 mins Well done 75~85 mins
Rolled, boned shoulder	1 kg	200 °C	Medium 50~60 mins Well done 75~85 mins
<b>Pork</b>			
Boned leg	900 g	240 °C	60 ~ 75 mins

**When using the rotisserie, the maximum weight of meat is 2.5kg, and the maximum weight of poultry is 1.8kg.**

The cooking time can be adjusted according to your preference.

Place the fat filter in the oven if you are going to roast.

**Note :** Place the meat on the middle of the rotisserie skewer and fasten as firmly as you can. If you are cooking poultry remember to secure the wings and legs with thread as tightly as possible.

# Using the oven

## Safety Lock

The oven is fitted with a SAFETY LOCK function.

Before starting a cooking programme

- The appliance cannot be operated.

After starting a cooking programme

- It prevents settings being changed accidentally.

### To activate SAFETY LOCK

While the oven is on, press and hold the Timer key for about 4 seconds until “It is locked” appears in the display.

### De-activating SAFETY LOCK

While the oven is on, press and hold the Timer key for about 4 seconds until “It is unlocked” appears in the display.

## Energy efficiency

These appliances are rated energy efficiency class A in accordance with EN 50304. Tests were carried out using Convection heat.

## Safety cut-out

If the oven has been operating for an extended period with no change in settings. It is automatically switched off.

### Maximum operating time

Below 100°C - 12 hours

100°C ~ 240°C - 8 hours

240°C ~ 300°C - 4 hours

### Restarting after safety cut-out

Press the Home or Back space key. You can now use the oven in the normal way.



---

## Rapid heat-up

The oven is supplied with rapid heat-up switched off. If you want to use rapid heat-up function, you first have to activate it. See “Changing settings - Heating up phase” for details.

Rapid heat-up engaged when Convection heat, Hot air, Conventional heat functions are selected.

During the rapid heat-up phase the top and rear element in the oven are used to reach the required temperature as quickly as possible.

## Canceling the rapid heat-up

To cancel the rapid heat-up function you have to change the setting to “Normal”. See “Changing settings - Heating up phase” for details.

Rapid heat-up should be switched off during the heating up phase when baking delicate items such as pizza, biscuits and small cakes. Because they will brown too quickly from the top.

# Speed Cook

## Using the speed cook

You can use the speed cook functions by selecting the Speed Cook menu in main display.

## Speed cook functions

### ❑ Speed roast

In this operating mode, upper elements and the fan on the rear wall are on. The pre-set temperature is 190°C.

### ❑ Speed grill

In addition to the grill element, Speed Grill uses the upper halogen heating element. If you select this function, the temperature is preset and cannot be adjusted.

A Duration can be entered if desired. If no Duration is entered cooking will continue until the maximum operating time has expired.

(Refer to page 32)

The two functions enable you perform the speed cooking by the aid of the upper halogen heater.

### ❑ Speed autocook

In this operating mode, cooking times can be cut by 50%, thanks to the optimum combination of halogen energy, conventional and convection heating methods.

If you select Speed autocook, you will be taken to the next step.



- 1 Select the menu you want.
- 2 Press the **Enter(✓)** key to confirm your selection.

You can now select the weight using the **Up(∧)**, **Down(∨)** and **Enter(✓)** key. The oven will do the rest for you. For further information, see “Speed autocook table”.

**Note :** In manual start mode you have to select and confirm the word “Start” to start programme. Refer to “Changing settings”.

# Healthy Roast

---

## Using the Healthy Roast

If you select Healthy Roast in main display, you can now use either Low temp cook or Meat Probe function.

**Note :** The meat probe must not be used at the same time as the rotisserie. The probe would entangle and immediately damage.

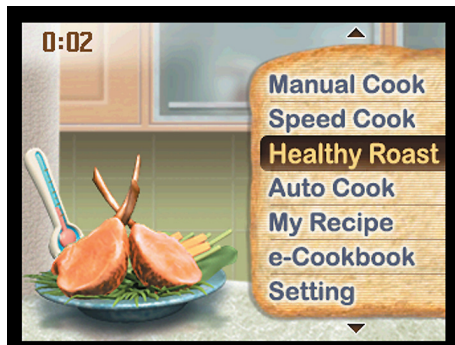

# Healthy Roast

## Low temp cook

With the Low temp cook function, meat becomes marvelously tender and remains particularly succulent. Up to 20 percent less energy is consumed than with normal roasting, when roasting with low temperatures.

### □ Ovenware

- At low temperatures, always roast meats uncovered.

### □ Oven levels and cooking times

- You can find the proper shelf position and cooking time in the following table.

		Preheating	Cooking		
Type of food	Weight (Kg)	Temp. (°C)	Temp. (°C)	Time (mins)	Oven level
Roast beef	1 - 1.5	150	90	110 - 130	2
Fillet of beef	1 - 1.5	150	90	95 - 120	2
Roast veal	1 - 1.5	150	90	120 - 140	2

### Tips for the Low temp cook

- Preheat the oven for about 5 minutes. When the preheating procedure is completed, you will hear a signal tone.
- The oven switches automatically to a temperature of 90°C. This remains constant for the whole of the cooking time.
- After searing the meat in a very hot frying pan, place it in a underneath it and then roast it in the preheated oven.

## Meat Probe

The meat probe enables the monitoring of internal food temperature during the roasting or baking process.

The meat probe can be used with Convection heat, Conventional heat and Fan grill functions in the Healthy roast menu.

### Using the Meat Probe

1. Push the probe as deeply as possible into the meat. The tip of the probe must reach the central area of the meat.
2. Insert the plug of the probe into the socket as far as it will go.
3. Select the desired oven function.
4. Set the desired oven temperature and meat probe temperature.

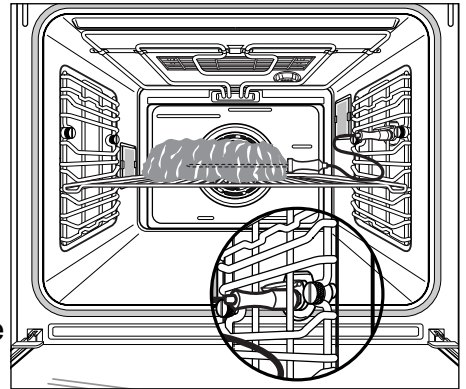

**Note :** The oven temperature can be set up to 250°C for safety reasons. The maximum probe temperature you can set is 99°C. If the preset oven temperature is under 99°C, then the core temperature cannot be set higher than the preset oven temperature.

# Healthy Roast

---

When pre-set core temperature is reached, you can hear a signal tone. and the oven will switch off automatically.

## Removing the meat probe

**Note :** The meat probe becomes very hot, Be careful when removing the plug and the tip of the meat probe.

1. Switch off the appliance.
2. Remove the plug from the socket, and take the meat out of the oven.

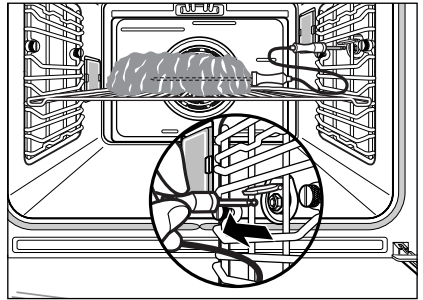

## Important :

Only use the temperature probe recommended for this oven.

## Note :

Wipe with a damp cloth. Do not put the meat probe into water, or clean It in the dishwasher. This would damage it.

# Auto cook

## Using the Auto Cook

Auto Cook function allows you to cook 40 menus of your favorite foods without selecting operating function, temperature and times. With this function, you can reduce the cooking time thanks to the optimum combination of heating elements.

If you select Auto Cook, the cook category appears in the display.

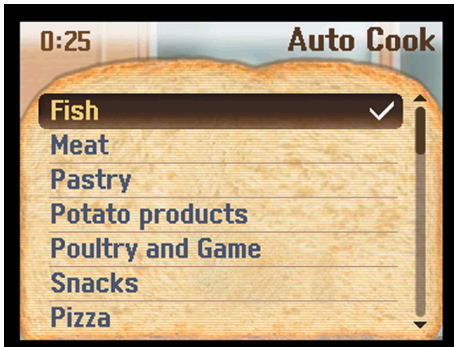

- 1 Press the **Up**( $\wedge$ ) or **Down**( $\vee$ ) **key** until the category you want is highlighted in the display.
- 2 Press the **Enter**( $\checkmark$ ) **key** to confirm your selection.

If you select a cook category, e.g. Fish, you will be taken to the next level within that option.



- 1 Select the menu you want.
- 2 Press the **Enter**( $\checkmark$ ) **key** to confirm your selection.

You can then select the weight of the dish using the up, down and **Enter**( $\checkmark$ ) **key**. Select and confirm the one you want.



The oven will do the rest for you. See “Auto cook table” for more information.

# My Recipe

The settings used frequently can be saved under a user-defined name and used as required.

A maximum of 20 user-defined programmes can be stored.

## Storing the setting

### Select the My Recipe.

If you have not yet created a recipe only the word “Create” will appear in the display.

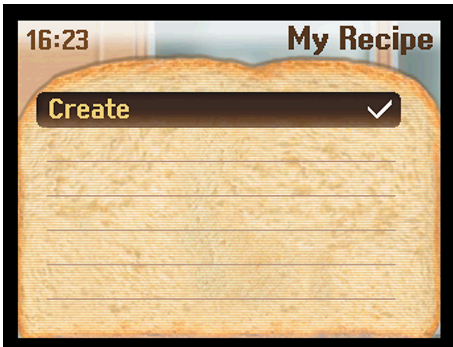

- 1 Select the option “Create”.
- 2 Select and confirm the function you want.  
Change the recommended temperature and duration if necessary by using the **Up** (∧), **Down**(∨) and **Enter** (✓) keys.
- 3 Save the create function by highlighting the Ok icon and pressing the **Enter**(✓) key.

The following will then appear in the display.

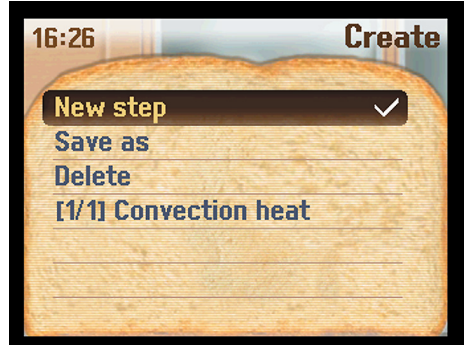

### New step

You can store up to 4 different cooking stages within each created programme by selecting ‘New step’ and repeating the last 3 instruction steps.



## ❑ Save as

You can save each created programme you made using a name of your choice.

- 1 After storing a 'Create' programme, scroll down to the 'Save as' function and press the **Enter(✓)** key.
- 2 Press the **Up(^)** or **Down(∨)** key until the letter you want is highlighted in the display.
- 3 Confirm your choice by pressing the **Enter(✓)** key. Your name will start to appear in the display. If you make a mistake you can use "←" symbol to delete the last letter or number you entered.
- 4 Check all your settings and then confirm your selection. You can then call up your programme using the name you gave it. You can even put it into the initial stage if you wish. See "Changing settings - Initial stage".

## ❑ Delete

You can delete the stage you create individually.

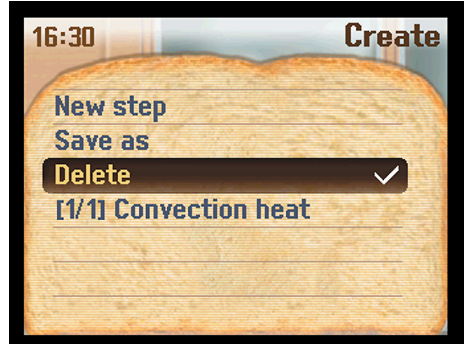

- 1 Select the word "Delete".

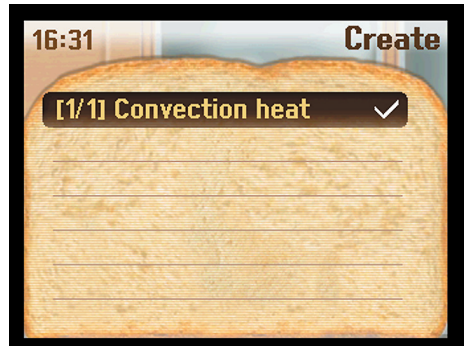

- 2 Select the stage to be deleted in the display.
- 3 Confirm your choice by pressing the **Enter(✓)** key.

Now the stage you have selected is deleted.

**Note :** If you have saved a recipe by name, you can not delete a stage within that recipe individually.

# e-Cookbook

## Using the e-Cookbook

This oven allows you to use e-Cookbook function providing over 120 recipes through TFT COLOR LCD display.

If you select e-Cookbook, the 12 cook categories appear in the display.



1 Press the **Up**( $\wedge$ ) or **Down**( $\vee$ ) **key** until the category you want is highlighted in the display.

2 Press the **Enter**( $\checkmark$ ) **key** to confirm your selection.

The scroll bar indicate that there are further options. You can see them by pressing the **Up**( $\wedge$ ) or **Down**( $\vee$ ) **key**.

If you select a category e.g. Starters, you will be taken to the next step within that option.

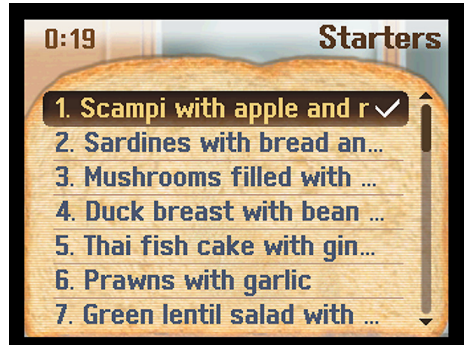

1 Select and confirm the menu you want.

If you select one of the menus, the words "Show recipe" and "Start cooking" are appear in the display.



e.g. Scampi with apple and red cabbage.

## ❑ Show recipe

If you select “Show recipe”, the full recipe including the ingredients appear in the display. You can then select and confirm the word “Start cooking”.



If you select one of the menus, corresponding picture appear in the display for some menus.

## ❑ Start cooking

If you select “Start cooking”, you will be taken to the next step within that option.

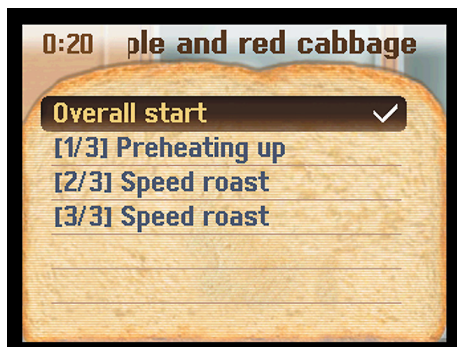

The oven will be operated with overall stages the menu has if you select “Overall start”.

You can also use each stage the menu has by selecting the one you want and confirming your selection.

## Note :

After preheating if you leave the oven on for more than 1 hour without opening the door, the cooking will be cancelled.

# Changing settings

The oven is supplied with preset basic settings. You can change these settings individually.

**Proceed as follows :**

- 1 Switch the oven on.
- 2 Select 'Setting' in the display and press the **Enter(✓)** key.

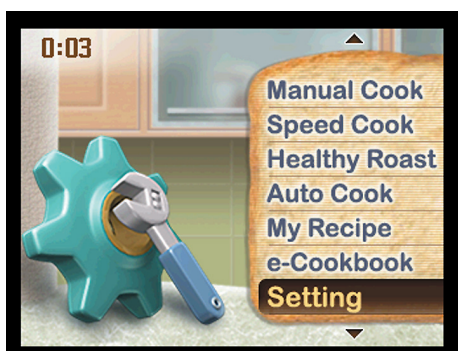

- 3 Select and confirm the basic settings you wish to change.

- **To select**  
Press the **Up(∧)** or **Down(∨)** key.
- **To confirm**  
Press the **Enter(✓)** key.

## Language

You can select either English or German.

- 1 Select and confirm the language you want.

The language you have selected will appear in the display.

## Clock

You can select either 12h-clock or 24h-clock.

- 1 Select and confirm the one you want. The time of day can then be set.
- 2 Enter and confirm the hour. Then enter and confirm the minutes. The time of day is now saved.

## Heating up phase

You can select Normal or Rapid.

- 1 Select and confirm the one you want.

If the option “Rapid” has been selected, the message “Rapid Heat Up” will appear in the display during the heating-up phase.

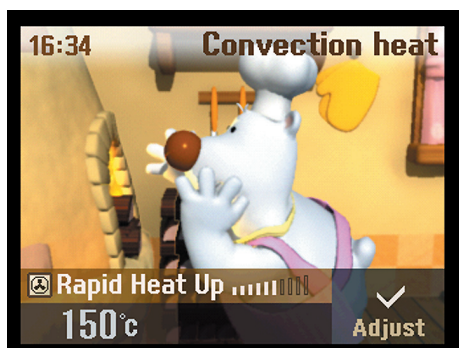

### Information

If Rapid heating is selected, it will only operate in the Convection, Hot air and Conventional heat mode.

## Oven lighting

You can select either On for 20 seconds or Fully on.

- 1 Select and confirm the one you want.

If you select “On for 20 seconds”, the oven lighting goes out 20 seconds after a cooking programme has started. The oven lighting also can stay on for maximum 3 hours if you select “Fully on”.

In pyrolytic cleaning function, the oven lamp cannot be switched on during operating.

# Changing settings

---

## Display

If you select “Display”, you will be taken to the next step within that option.

### Display

You can select Normal or Power saving.

- 1 Select and confirm the one you want.

If you select “Power saving”, the display will be dimmed in about 10 minutes after the last entry was made.

But if you select “Normal” the display will not be dimmed during operating.

### Brightness

The brightness can be adjusted.

- 1 Select and confirm the setting you want.

The preset level is “3”.

### Animation

You can select either “Default” or “Character”.

- 1 Select and confirm the one you want.

If you select “Default”, the display only shows the LG icon, letters, and a colored background during the cooking.

Additionally the display shows a specific character decorating the display window visually if you select “Character”.

## Sound

The key sounds can be switched on or off . If you select “OFF”, the key sounds will not be rung during operating.

- 1 Select and confirm the one you want.

## Default setting

You can select My recipes or All setting.

- 1 Select and confirm the one you want.

When you select “My recipes”, a message will appear in the display. You can then delete all my recipes if you wish.

If you select “All setting”, any settings that you have altered will be reset to the factory default setting.

My recipes will also be deleted

## Start

You can select either Automatic or Manual.

- 1 Select and confirm the setting want.

If you select “Automatic”, the cooking programme will start automatically about 5 seconds after the last entry is made or by selecting the start option before 5 seconds expires.

In manual start, you must confirm the start option to start the cooking function.

## Temperature

The preset temperature for each Manual cook function can be changed in this setting as an alternative to the default set temperature.

- 1 Select and confirm the function you want.
- 2 Change the temperature.

## Initial stage

You can select or change the main menu that appears in the display each time the oven is turned on.

- 1 Select and confirm the one you want.

Initial stage is now changed.

# ***Speed autocook table***

## **Speed autocook**

<b>Menu</b>	<b>Category</b>	<b>Weight limit</b>	<b>Step</b>	<b>Utensil</b>
SP-1	Salmon, steak	400 ~ 1200g	200g	Deep pan + Grill tray
SP-2	Jumbo Shrimps	300 ~ 1000g	100g	Deep pan + Grill tray
SP-3	Meat loaf	600 ~ 1200g	200g	Wire grill + Heat proof glass dish
SP-4	Leg of lamb	1000 ~ 2000g	500g	Wire grill + Heat proof glass dish
SP-5	Roast veal	1000 ~ 2000g	500g	Wire grill + Heat proof glass dish
SP-6	Roast potatoes	400 ~ 1600g	200g	Wire grill + Heat proof glass dish
SP-7	French fries, frozen	250 ~ 750g	250g	Baking tray + Baking paper
SP-8	Chicken, whole	1000 ~ 2000g	250g	Deep pan + Grill tray
SP-9	Chicken, legs	600 ~ 1800g	200g	Deep pan + Grill tray
SP-10	Pizza, frozen, thin base	200 ~ 400g	100g	Wire grill



	<b>Food Temp.</b>	<b>Oven level, from bottom</b>	<b>Instructions</b>
	Refrigerated	5	See the instructions on page 51
	Refrigerated	5	See the instructions on page 51
	Refrigerated	4	See the instructions on page 53
	Refrigerated	2	See the instructions on page 53
	Refrigerated	2	See the instructions on page 53
	Room	4	See the instructions on page 55
	Frozen	5	See the instructions on page 55
	Refrigerated	2	See the instructions on page 57
	Refrigerated	5	See the instructions on page 57
	Frozen	1	See the instructions on page 61

To avoid residual cooking, remove food from oven immediately.

You can adjust the preset cooking time according to the food performing or your preference. Press the OK key to call up the setting display.

# ***Auto cook table***

## **Fish**

<b>Menu</b>	<b>Category</b>	<b>Weight limit</b>	<b>Step</b>	<b>Utensil</b>	<b>Food Temp.</b>
1-1	Trout	600-1600g	200g	Deep pan + Grill tray	Refrigerated
1-2	Salmon, steak	400-1200g	200g	Deep pan + Grill tray	Refrigerated
1-3	Tuna, steak	400-1200g	200g	Deep pan + Grill tray	Refrigerated
1-4	Jumbo Shrimps	300-1000g	100g	Deep pan + Grill tray	Refrigerated

<b>Oven level, from bottom</b>	<b>Instructions</b>
3	Choose trout of 300-400g weight each. Brush with oil or melted butter, season as desired. Place trout on deep pan with grill tray and insert into oven. When oven beeps, turn food over.
3	Choose salmon steaks of 200g weight and 2.5cm thickness each. Brush salmon with oil or melted butter, season as desired. Place salmon onto deep pan with greased grill tray. When oven beeps, turn food over.
4	Choose tuna fish steaks of 200g weight and 2.5cm thickness each. Brush tuna fish with oil or melted butter, season as desired. Place tuna steak onto deep pan with greased grill tray. When oven beeps, turn food over. It is normal for the tuna to be a little pink inside after cooking.
4	Remove feelers of shrimps. Brush with oil or melted butter. Season as desired, place shrimps onto deep pan with grill tray. Insert into oven. When oven beeps, turn food over.

To avoid residual cooking, remove food from oven immediately.

You can adjust the preset cooking time according to the food performing or your preference. Press the OK key to call up the setting display.

# ***Auto cook table***

## **Meat**

<b>Menu</b>	<b>Category</b>	<b>Weight limit</b>	<b>Step</b>	<b>Utensil</b>	<b>Food Temp.</b>
2-1	Roast beef	1000-2500g	500g	Wire grill + heat proof glass dish	Refrigerated
2-2	Spare ribs	800-1400g	200g	Deep pan + Grill tray	Refrigerated
2-3	Meat loaf	600-1200g	200g	Wire grill + heat proof glass dish	Refrigerated
2-4	Roast pork	1000-2500g	500g	Wire grill + heat proof glass dish	Refrigerated
2-5	Leg of lamb	1000-2000g	500g	Wire grill + heat proof glass dish	Refrigerated
2-6	Roast Veal	1000-2000g	500g	Wire grill + heat proof glass dish	Refrigerated

Oven level, from bottom	Instructions
2	Brush beef with oil or melted butter, season as desired. Put beef in open dish and insert into oven. When oven beeps, add a big cup of hot water and cover with lid. After cooking, allow to rest covered with foil for 10 minutes. Use generated juice for gravy or sauce.
3	Brush spare ribs with oil, season as desired and place onto deep pan with grill tray. Insert into oven. When oven beeps, turn food over.
2	Form a meatloaf using fresh minced meat, egg, some breadcrumbs and seasoning. Place into open dish and insert into oven.
2	Brush pork with oil or melted butter, season as desired. Place pork into dish, add a big cup of water, cover with lid and insert into oven. When oven beeps, remove lid. After cooking, allow to rest covered with foil for 10 minutes. Use generated juice for gravy or sauce.
2	Brush leg of lamb with oil or melted butter, season as desired. Place lamb into dish, insert into oven. When oven beeps, add a big cup of water and cover with lid. After cooking, allow to rest covered with foil for 10 minutes. Use generated juice for gravy or sauce.
2	Brush veal with oil or melted butter, season as desired. Place veal into dish, add a big cup of water, cover with lid and insert into oven. After cooking, allow to rest covered with foil for 10 minutes. Use generated juice for gravy or sauce.

To avoid residual cooking, remove food from oven immediately.

You can adjust the preset cooking time according to the food performing or your preference. Press the OK key to call up the setting display.

# Auto cook table

## Pastry

Menu	Category	Weight limit	Step	Utensil	Food Temp.
3-1	Croissants	120-600g	120g	Baking tray + baking paper	Refrigerated
3-2	Small bread, bake off	100-600g	100g	Wire grill	Room

## Potato products

Menu	Category	Weight limit	Step	Utensil	Food Temp.
4-1	Gratinated potatoes	500-1500g	500g	Wire grill + heat proof glass dish	Room
4-2	Roast potatoes	400-1600g	200g	Wire grill + heat proof glass dish	Room
4-3	French fries, frozen	250-750g	250g	Baking tray + baking paper	Frozen
4-4	Croquettes, frozen	250-500g	250g	Baking tray + baking paper	Frozen

Oven level, from bottom	Instructions
2	Place croissants on baking tray with baking paper. Brush croissants with milk or water and insert into oven.
3	Brush small bread or rolls with water or milk. Place on wire grill and insert into oven.

Oven level, from bottom	Instructions
2	Cut pre-cooked gratin potatoes into slices. Place potatoes in dish, cover with grated cheese (30g per 500g gratin potatoes) and insert into oven.
2	Choose small potatoes (100-150g each). Peel, wash, dry and cut potatoes into halves. Mix potatoes with salt, pepper and oil or melted butter and put into open dish. Insert into oven. When oven beeps, turn food over.
4	Spread frozen fries evenly on baking tray with baking paper. For best results, cook in a single layer. Insert baking tray into oven. When oven beeps, turn food over. After cooking, season with salt or as desired.
4	Spread frozen croquettes on baking tray, insert into oven. When oven beeps, turn food over. After cooking, season with salt or as desired.

To avoid residual cooking, remove food from oven immediately.

You can adjust the preset cooking time according to the food performing or your preference. Press the OK key to call up the setting display.

# ***Auto cook table***

## **Poultry and game**

<b>Menu</b>	<b>Category</b>	<b>Weight limit</b>	<b>Step</b>	<b>Utensil</b>	<b>Food Temp.</b>
5-1	Chicken, whole	1000-2000g	250g	Deep pan + Grill tray	Refrigerated
5-2	Chicken, legs	600-1800g	200g	Deep pan + Grill tray	Refrigerated
5-3	Duck, whole	1700-2500g	200g	Deep pan + Grill tray	Refrigerated
5-4	Turkey, whole	3200-4700g	500g	Deep pan + Grill tray	Refrigerated



Oven level, from bottom	Instructions
2	Brush chicken with oil or melted butter, season as desired. Place chicken onto deep pan with grill tray. Add water to deep pan. Insert into oven. When the oven beeps, turn food over. After cooking, allow to rest covered with foil for 10 minutes. Use generated juice for gravy or sauce.
3	Brush chicken legs with oil or melted butter, season as desired. Place chicken legs onto grill tray, fill water into deep pan, put grill tray on top and insert into oven. When oven beeps, turn food over. After cooking, allow to rest covered with foil for 3 minutes. Use generated juice for gravy or sauce.
2	Brush duck with oil or melted butter, season as desired. Wrap thin part of the legs in foil, place duck onto deep pan with grill tray. Add water to deep pan. Insert into oven. After cooking allow to rest covered with foil for 5 minutes. Use generated juice for gravy or sauce.
1	Brush turkey with oil or melted butter, season as desired. Wrap thin part of the legs in foil, place turkey onto deep pan with grill tray. Add water to deep pan. When oven beeps, turn food over. If turkey gets too dark, cover with foil. After cooking, allow to rest covered with foil for 10 minutes. Use generated juice for gravy or sauce.

To avoid residual cooking, remove food from oven immediately.

You can adjust the preset cooking time according to the food performing or your preference. Press the OK key to call up the setting display.

# ***Auto cook table***

## **Poultry and game**

<b>Menu</b>	<b>Category</b>	<b>Weight limit</b>	<b>Step</b>	<b>Utensil</b>	<b>Food Temp.</b>
5-5	Turkey, legs	800-2000g	400g	Deep pan + Grill tray	Refrigerated
5-6	Hare, parts	700-2100g	700g	Deep pan	Refrigerated
5-7	Goose, whole	3500-5000g	500g	Wire grill + Deep pan	Refrigerated
5-8	Goose, legs	800-2000g	400g	Deep pan + Grill tray	Refrigerated
5-9	Roast venison, back	1000-2000g	500g	Wire grill + heat proof glass dish	Refrigerated

Oven level, from bottom	Instructions
2	Brush turkey legs with oil or melted butter, season as desired. Wrap thin part of the legs in foil. Place legs onto deep pan with grill tray. Add water to deep pan. Insert into oven. When oven beeps, turn food over. After cooking, allow to rest covered with foil for 3 minutes. Use generated juice for gravy or sauce.
3	Brush hare/rabbit pieces with a little mustard, season as desired and place onto greased deep pan. Insert into oven. When oven beeps, turn food over. Use generated drip for gravy or sauce.
2+1	Brush goose with oil or melted butter, season as desired. Place goose onto wire grill and insert into oven placing deep pan underneath to catch dripping fat. When oven beeps, turn food over. If goose gets too dark, cover with foil. After cooking, allow to rest covered with foil for 10 minutes. Use generated juice for gravy or sauce.
3	Brush goose legs with oil or melted butter, season as desired. Place legs onto deep pan with grill tray. Add water to deep pan. Insert into oven. When oven beeps, turn food over. After cooking, allow to rest covered with foil for 3 minutes. Use generated juice for gravy or sauce.
2	Marinate venison for at least 24 hours. Brush venison with oil or melted butter, season as desired. Put venison in open dish and insert into oven. After cooking, allow to rest covered with foil for 10 minutes. Use generated juice for gravy or sauce.

To avoid residual cooking, remove food from oven immediately.

You can adjust the preset cooking time according to the food performing or your preference. Press the OK key to call up the setting display.

# Auto cook table

## Snacks

Menu	Category	Weight limit	Step	Utensil	Food Temp.
6-1	Crumbed squid rings, frozen	200-600g	200g	Baking tray + baking paper	Frozen
6-2	Meat on skewers	400-900g	250g	Deep pan + Grill tray	Refrigerated
6-3	Cordon Bleu, frozen	340-1360g	170g	Wire grill + Baking tray	Frozen

## Pizza

Menu	Category	Weight limit	Step	Utensil	Food Temp.
7-1	Pizza, frozen, thin base	200-400g	100g	Wire grill	Frozen
7-2	Pizza, frozen, thick base	400-500g	100g	Wire grill	Frozen

<b>Oven level, from bottom</b>	<b>Instructions</b>
4	Spread frozen squid rings evenly on baking tray with baking paper. Insert into oven. When oven beeps, turn food over.
4	Place meat on skewers on greased grill tray with deep pan. Insert into oven. When oven beeps, turn food over.
3+2	Spread frozen Cordon bleu evenly on wire grill. Insert into oven, placing baking tray underneath to catch dripping liquid.

<b>Oven level, from bottom</b>	<b>Instructions</b>
1	Place frozen pizza on wire grill. Insert into oven. Use only one frozen pizza at a time.
2	Place frozen pizza on wire grill. Insert into oven. Use only one frozen pizza at a time.

To avoid residual cooking, remove food from oven immediately.

You can adjust the preset cooking time according to the food performing or your preference. Press the OK key to call up the setting display.

# ***Auto cook table***

## **International automatic recipes**

<b>Menu</b>	<b>Category</b>	<b>Utensil</b>
8-1	Lasagna	Wire grill + heat proof lasagna dish
8-2	Homemade pizza	Deep pan
8-3	White bread	Wire grill + bread baking tin
8-4	Quiche Lorraine	Wire grill + round baking tin
8-5	Sea bream	Deep pan
8-6	Guglhupf	Wire grill + Guglhupf tin
8-7	Muffins	Wire grill + muffin tin
8-8	Moussaka	Wire grill + heat proof dish
8-9	Cinnamon buns	Baking tray + deep pan
8-10	Swedish apple pie	Wire grill + round baking tin

<b>Oven level, from bottom</b>	<b>Instructions</b>
2	See the recipe on page 64
2	See the recipe on page 65
1	See the recipe on page 66
1	See the recipe on page 66~67
2	See the recipe on page 68
1	See the recipe on page 69
2	See the recipe on page 70
2	See the recipe on page 70~71
2+4	See the recipe on page 72
1	See the recipe on page 73

To avoid residual cooking, remove food from oven immediately.

You can adjust the preset cooking time according to the food performing or your preference. Press the OK key to call up the setting display.

# ***Auto cook table***

---

## **8-1. Lasagna**

### **Ingredients:**

- 300 g ground beef
- 1 small onion
- 1-2 garlic gloves, sliced
- 1 can peeled plum tomatoes (400 g)
- 1 can chopped tomatoes (400 g)
- 75 g tomato paste
- 1 can diced tomatoes (40 g)
- 250 g shredded mozzarella cheese
- 200 g crème fraîche
- 6-8 lasagne noodles
- Fresh basil leaves
- Pepper, salt, oregano

### **Preparation:**

- Cook onion and garlic, then add meat, cook until no longer pink.
- Add all tomatoes, simmer for approx. 1 hour.
- Add pepper and salt for taste, then add basil.
- Let sauce cool.
- Pre-cook noodles if required.
- Put some sauce at bottom of lasagne pan, place noodles on top, then crème fraîche, then mozzarella.
- Sprinkle with oregano.
- Repeat placing noodles in other direction.
- Sprinkle with oregano.



---

## 8-2. Homemade pizza

### Ingredients:

- 15 g fresh yeast
- 250 ml warm water
- 1 tsp. salt
- 450 g flour
- 1 tsp. sugar
- 2 tbsp. vegetable oil
- 1 small jar tomato sauce
- 450 g ground beef, browned
- 200 g pepperoni slices
- 2 peppers, sliced
- 1 large onion
- 100 g sliced olives
- 450 g shredded mozzarella cheese

### Preparation:

- Dissolve yeast in warm water.
- Stir in salt and sugar.
- Add flour slowly, kneading constantly.
- Add oil and keep kneading.
- If dough is sticky, add a little more flour.
- Cover dough and allow to rise for 1/2 hour.
- Using floured hands, knead dough and spread it on greased cookie sheet with fingertips.
- Spread tomato sauce over dough, add toppings in layers.
- Sprinkle cheese over dough.

# ***Auto cook table***

---

## **8-3. White bread**

### **Ingredients:**

- 500 g flour
- 1 package dry yeast
- 325 g lukewarm milk
- 5 g salt

### **Preparation:**

- In a big bowl, mix flour and salt.
- Dissolve yeast in lukewarm milk and add to flour.
- Knead until a smooth dough is formed.
- Add a little more milk if required.
- Cover dough and allow to rise for about 40-50 minutes.
- Place dough in a greased bread baking tin.
- Allow dough to rise for another 10-20 minutes.
- Dust bread with flour before baking.
- Using a sharp knife, cut bread diagonally 3-4 times, approx. 1 cm deep.
- If desired, brush with a little butter after baking and cooling down.

## **8-4. Quiche lorraine**

### **Ingredients for short pastry:**

- 200 g plain flour
- 1/2 tsp. salt
- 85 g butter
- 1 egg
- 1 tbsp. white wine vinegar

### **Ingredients for filling:**

- 250 g thick bacon
- 5 eggs
- 300 ml cream
- Salt and pepper
- 1/4 tsp. freshly grated nutmeg
- 200 g grated cheese, Gruyère or cheddar (optional)

---

### **Preparation of short pastry:**

- In a large bowl or food processor sift flour and salt.
- Cut cold butter into small cubes and add to flour.
- Rub butter into flour using both hands or food processor, until it resembles fine breadcrumbs.
- Make a well in the centre, add 1 beaten egg and vinegar mixing to a firm dough.
- If dough seems a little dry add a little water.
- Handle as little as possible as this prevents pastry from becoming hard when baked.
- Roll into a ball, cover with plastic wrap and refrigerate for 30 minutes.

### **Preparation of filling:**

- Cut bacon into small strips, sauté until crisp and put aside to cool.
- Whisk together eggs, cream, grated nutmeg and pepper in a large bowl.

### **Assembly:**

- On a lightly floured board roll out short pastry until approx. 5 mm thick.
- Line flan or pie dish with dough, flute and crimp edges decoratively.
- Scatter half the cheese over the bottom of the pie crust.
- Continue by placing cooled bacon over evenly and pour in egg and cream filling mixture.
- Sprinkle with remaining cheese.
- Let quiche cool for 15 minutes before cutting.

# ***Auto cook table***

---

## **8-5. Sea bream**

### **Ingredients:**

- 4 peppers
- 6-8 tomatoes
- 3 onions
- 1 kg sea bream
- 8 tbsp. olive oil
- 3 tbsp. white wine
- 3 garlic gloves
- Rosemary and thyme
- Salt and pepper

### **Preparation:**

- Cut peppers, tomatoes and onions into cubes and distribute on a baking sheet.
- Sprinkle with some olive oil and white wine, season with salt and pepper.
- Season fish with salt and pepper as well and put onto vegetables.
- Again sprinkle with olive oil and white wine.
- Put rosemary, thyme and garlic slices on top of the fish.

---

## 8-6. Marble guglhupf

### Ingredients:

- 1 Tahitian vanilla pod
- 200 g soft butter
- 180 g sugar
- 4 eggs
- 2 tablespoons rum
- 350 g flour
- 20 g baking powder
- 200 g cream
- 100 g dark chocolate
- 1 tablespoon butter
- A little flour
- Icing sugar

### Preparation:

- Cut vanilla pod open lengthwise, scratch out inside with a sharp knife and mix with butter and sugar until creamy.
- Gradually beat in eggs, whisking until frothy and then add rum.
- Sieve flour and baking powder and stir into egg mixture.
- Stir in cream and split mixture into 2 even-sized portions.
- Melt chocolate and stir evenly into one portion of mixture.
- Grease Guglhupf tin (1 1/2 litre capacity) with butter and dust with a little flour.
- Put half of the light mixture into tin, pour dark half onto it and cover with rest of light mixture.
- Run a fork through the mixture in the shape of a spiral to achieve desired marbling effect.
- Allow to cool a little.
- Turn out of tin, leave to cool and dust with icing sugar.

# ***Auto cook table***

---

## **8-7. Muffins**

### **Ingredients:**

- 150 g flour
- 1 1/2 tsp. baking powder
- 60 g granulated sugar
- 1 egg, beaten
- 130 ml milk
- 70 ml vegetable oil
- 1/2 tsp. vanilla extract
- 50 g semisweet chocolate chips
- 50 g chopped walnuts
- Sifted confectioners' sugar

### **Preparation:**

- Combine flour and sugar in a mixing bowl; make a well in centre of mixture.
- Combine remaining ingredients except for confectioners' sugar; add to dry ingredients, stirring just until moistened.
- Spoon into greased and floured muffin pans, filling about two-thirds full.
- Remove from pans and sprinkle with confectioners' sugar.

## **8-8. Moussaka**

### **Ingredients:**

- 1 large eggplant
- 450 g ground beef or lamb
- Vegetable oil
- 2 medium onions, chopped
- 2 cloves garlic, minced
- 1 tsp. salt
- 1/2 tsp. thyme
- 1/2 tsp. oregano
- 1/2 tsp. nutmeg
- 2 tbsp. chopped parsley
- 280 g canned tomatoes
- 120 ml white wine
- 2 egg whites
- 30 g bread crumbs
- 2 tbsp. grated Parmesan cheese
- 60 g butter
- 3 tbsp. flour
- 350 ml milk
- 2 egg yolks
- 1/2 tsp. salt
- 1/4 tsp. pepper

---

**Preparation:**

- Pare eggplant and cut into 1.5 cm thick slices.
- Sprinkle with salt and set aside for 30 minutes.
- Rinse and dry thoroughly.
- Brown meat in vegetable oil with onions and garlic.
- Drain off the fat.
- Add salt, seasonings, parsley, tomatoes and wine.
- Cover and cook slowly for 30 minutes, then cool.
- Mix in unbeaten egg whites and half of the crumbs.
- Brown eggplant slices in vegetable oil.
- Sprinkle bottom of a rectangular baking dish (approx. 20 x 30 cm) with remaining crumbs.
- Cover with eggplant.
- Spoon meat mixture over eggplant.
- Melt butter, add flour slowly, stirring constantly.
- Remove from heat, slowly stir in milk.
- Return to heat and stir until sauce thickens.
- Beat egg yolks well, gradually stir yolks, salt and pepper into the sauce, blend well.
- Pour sauce over this mixture.
- Top with cheese.

# *Auto cook table*

---

## **8-9. Cinnamon buns (Kanelbullar)**

### **Ingredients (for 2 sheets):**

- 1 cube fresh yeast
- 50 g sugar
- 75 g unsalted butter
- 250 ml milk
- 1/2 tsp. cardamom
- 500 g flour
- 60 g unsalted butter, softened
- 5 tbsp. sugar
- 4 tsp. cinnamon
- 1 egg, beaten
- Pearl sugar

### **Preparation:**

- Melt butter over low heat.
- Pour in cold milk.
- Wait until the butter-milk mixture is finger warm.
- Dissolve yeast in the mixture and let rest for 5 minutes.
- Stir in sugar, cardamom and flour.
- Gather dough into a ball and knead until smooth and shiny.
- Cover dough and allow to rise until nearly double in size, about 30 minutes.
- Turn dough out onto a floured surface and knead again until smooth and shiny.
- Divide dough into two parts.
- Roll each part out into a rectangle about 6 mm thick.
- Spread half of the softened butter over each rectangle.
- Stir together the remaining sugar and the cinnamon and spread half of the mixture on each rectangle.
- Roll the rectangles up and cut into 1,5 cm thick slices.
- Place slices on a cookie sheet (greased or covered in parchment paper).
- Cover and let rise again for about 30 minutes while preheating the oven, brush tops of buns with beaten egg and sprinkle with pearl sugar.



---

## 8-10. Swedish apple pie

### Ingredients:

- 5 green apples, peeled and sliced
- 1 tbsp. sugar
- 1 tsp. cinnamon
- 170 g melted butter
- 120 g flour
- 200 g sugar
- 1 egg
- 75 g chopped nuts (pecans or walnuts)
- Pinch of salt

### Preparation:

- Fill a greased baking tin  $\frac{2}{3}$  full of apples.
- Sprinkle with 1 tablespoon sugar and the cinnamon.
- Mix together remaining ingredients.
- Pour over apples.

# Baking

## General information

When baking, use the Convection heat(☑) or Conventional heat (☐) modes.

## Baking tins

- When baking in Conventional heat(☐) modes, use baking tins with a dark metal or coated surface.
- When baking with Convection heat(☑), you can also use baking tins with a bright metal surface.
- Always place cake tins in the middle of the tray or Wire grill.
- When baking with Conventional heat(☐), you can place two baking tins side by side in the oven. This means that the baking time is only slightly longer.
- When using 2 trays (baking tray and deep pan), place the deep pan on Level 5 and the baking tray on Level 2.

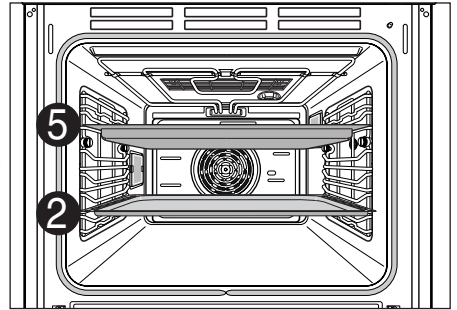

## Oven levels

The Oven levels are numbered from the bottom up.

When using Conventional heat(☐), you can bake on one level only, for example Level 4.

When using Convection heat(☑), you can bake sponge bases and biscuits up to 2 baking trays at the same time, for example on levels 2 and 5.

---

## Using baking tables

The tables contain the temperature settings, baking time and Oven levels for a selection of typical dishes.

- Temperatures and baking times should be regarded as reference figures only. The actual values depend on the type of preparation, quality of ingredients and the baking tin in use.
- We recommend first selecting a lower temperature and then increasing it if necessary, for example if you want a higher degree of browning or the baking time is too long.
- If you cannot work out the settings for a specific recipe, simply use the settings for the most similar recipe.
- When baking cakes on baking trays or in tins on more than one level, the baking time may be extended by 10 –15 minutes.
- Baking with a high liquidity content (e.g. pizza, fruit cakes, etc.) should be baked on a single level only.
- With cakes and baking with different levels of dough, uneven browning may take place initially. **In this case, do not alter the temperature setting.** The degree of browning will even itself out over the baking process.
- For energy saving, use the residual heat for 8 minutes before finishing cooking times.

# Baking Tables

## Baking on a single oven level

Operating mode	Convection heat		Conventional heat		Baking time For both types of baking, in hrs, mins.
	Oven level	Temp. in °C	Oven level	Temp. in °C	
<b>Cakes in baking tins</b>					
Ring-shaped pound cake	2	150–160	2	160–180	0:50–1:10
Biscuits / pancakes	2	140–160	2	150–170	1:10–1:30
Sponge finger	2	150–160	2	160–180	0:25–0:40
Flan base – shortcrust pastry	3	170–180	2	190–210 <sup>1)</sup>	0:10–0:25
Flan base – cake mixture	3	150–170	2	170–190	0:20–0:25
Apple pie	2	150–170	2	170–190	0:50–1:00
Spicy cakes and flan base (e.g. quiche lorraine)	2	160–180	2	190–210	0:30–1:10
Cheesecake <sup>3)</sup>	2	140–160	2	170–190	1:00–1:30
<b>Cakes on baking tray</b>					
Bread plaits / larger cakes	3	160–170	4	170–190	0:30–0:40
Christmas stollen	3	150–170 <sup>1)</sup>	4	160–180 <sup>1)</sup>	0:40–1:00
Bread (rye bread) initially, then later	2	180–200 <sup>1)</sup> 140–160	2	230 <sup>1)</sup> 160–180	0:20 0:30–1:00
Pie / éclair	3	160–170 <sup>1)</sup>	4	190–210	0:15–0:30
Swiss roll	3	150–170 <sup>1)</sup>	4	180–200 <sup>1)</sup>	0:10–0:20
Fruit cake with shortcrust pastry	3	160–170 <sup>1)</sup>	4	170–190 <sup>1)</sup>	0:40–1:20

Operating mode	Convection heat		Conventional heat		Baking time For both types of baking, in hrs, mins.
	Oven level	Temp. in °C	Oven level	Temp. in °C	
Slices with topping/ filling, e.g. quark, cream, sugar, almonds	–	–	4	160–180 <sup>1)</sup>	0:40–1:20
Pizza (thick base) <sup>2) 3)</sup>	1	180–200	1	190–210 <sup>1)</sup>	0:30–1:00
Pizza (thin base) <sup>2)</sup>	1	200–220	1	230 <sup>1)</sup>	0:10–0:25
Unleavened bread	1	200–220	1	230 <sup>1)</sup>	0:08–0:15
Wähe (Swiss flan)	1	180–200	1	210–230	0:35–0:50
<b>Biscuits<sup>2)</sup></b>					
Shortcrust biscuits <sup>2)</sup>	3	150–160	4	170–190 <sup>1)</sup>	0:06–0:20
Iced biscuits <sup>2)</sup>	3	140–150	4	160–180	0:10–0:40
Cake mixture biscuits <sup>2)</sup>	3	150–160	4	170–190	0:15–0:20
Cakes and pastries with egg white, meringues	3	80–100	4	100–120	2:00–2:30
Macaroons	3	100–120	4	120–140	0:30–0:60
Yeast dough biscuits <sup>2)</sup>	3	160–170	4	170–190	0:20–0:40
Puff pastry cakes and pastries	3	160–180 <sup>1)</sup>	4	190–210 <sup>1)</sup>	0:20–0:30
Bread rolls	3	180–200 <sup>1)</sup>	4	180–220 <sup>1)</sup>	0:20–0:35

1) Preheat the oven.

2) Switch off “rapid heat-up”.

3) Use deep pan.

Always count Oven levels from the bottom up.

# Baking Tables

## Baking on more than one oven level

Recipe	Hot air		Baking time in hrs, mins.
	Oven level	Temp. in °C	
<b>Cakes /cakes and pastries on baking sheet<sup>2)</sup></b>			
Pie / éclair <sup>2)</sup>	2/5	160–180 <sup>1)</sup>	0:35–0:60
Dry sponge cake with crumble topping <sup>2)</sup>	2/5	140–160	0:30–0:60
<b>Biscuits<sup>2)</sup></b>			
Shortcrust biscuits <sup>2)</sup>	2/5	150–160	0:15–0:35
Iced biscuits <sup>2)</sup>	2/5	140–150	0:20–0:60
Cake mixture biscuits <sup>2)</sup>	2/5	160–170	0:25–0:40
Cakes and pastries with egg white, meringues <sup>2)</sup>	2/5	80–100	2:10–2:50
Macaroons <sup>2)</sup>	2/5	100–120	0:40–1:20
Yeast dough cookies <sup>2)</sup>	2/5	160–170	0:30–0:60
Puff pastry cakes and pastries <sup>2)</sup>	2/5	170–180 <sup>1)</sup>	0:30–0:50
Bread rolls <sup>2)</sup>	2/5	180–190 <sup>1)</sup>	0:30–0:55

1) Preheat the oven.

2) Switch off “rapid heat-up”.

Always count Oven levels from the bottom up.

Place the deep pan on level 5.

## Table for strudel and baked dishes

	Conventional heat		Baking time in hrs, mins.
	Oven level	Temp. in °C	
Baked pasta	1	180–200	0:45–1:00
Lasagne	1	180–200	0:25–0:40
Baked vegetables	1	200–220 <sup>1)</sup>	0:15–0:30
Pizza baguette	1	200–220 <sup>1)</sup>	0:15–0:30
Soufflé	1	180–200	0:15–0:30
Fish pie	1	180–200	0:30–1:00
Stuffed vegetables	1	180–200	0:30–1:00

1) Preheat the oven.

Always count Oven levels from the bottom up.

## Baking tables for frozen ready-made dishes

Dish	Oven level	Oven function	Temperature	Time
Frozen pizza	3	Conventional Heat	Follow instructions on pack.	Follow instructions on pack.
Baguettes	3	Conventional Heat	Follow instructions on pack.	Follow instructions on pack.
Fruit cake base	3	Conventional Heat	Follow instructions on pack.	Follow instructions on pack.
Chips	3	Convection Heat	200–220°C	15–25 mins.

Always count Oven levels from the bottom up.

**Note:** Turn chips 2 or 3 times when heating.

When heating frozen dishes, the baking tray may bend out of shape because of the great difference in the temperature of the frozen food and the oven.

Trays normally return to their original shape once they have cooled down.

# Baking tables

## Baking tips

Results of baking	Possible cause	Solution
The cake base is too light	Wrong Oven level	Use a dark baking tin or put the cake one level lower down.
Cake collapses (turns lumpy, soggy)	Oven temperature too high	Set the temperature slightly lower.
	Baking time too short	Set a longer baking time. <b>The baking time cannot be reduced by setting a higher temperature.</b>
	Mixture contains too much liquid	Use less liquid. Follow instructions for dough mixing times, especially when using kitchen appliances.
Cakes are too dry	Oven temperature too low	Next time set a slightly higher temperature.
	Baking time too long	Set a slightly shorter baking time.
Cakes are browned unevenly	Baking temperature too high and baking time too short	Set a slightly lower baking temperature and a slightly higher baking time.
	Mixture unevenly distributed	Distribute the mixture evenly over the baking tray/tin.
Baking time too long	Temperature too low	Next time set a slightly higher temperature.



# Roasting

---

When roasting, use the Fan grill(☒), Conventional heat (☐) modes, or Speed roast(☐▶)mode. When using the Speed roast (☐▶) mode, the cooking time at the same temperature is reduced by 20% in comparison with the Fan grill function and the convection fan will cycle on and off.

## TIP:

- Use heat resistant dishes when roasting (follow manufacturer's instructions).
- Stainless steel roasting pans are only of limited use, as they reflect the heat to a very large extent.
- When using dishes with plastic handles, ensure that the handles are heat resistant (follow manufacturer's instructions).
- Large items for roasting or a number of items can be placed directly on the deep pan or on the wire grill above the deep pan (e.g. turkey, goose, 3~4 chickens, 3~4 knuckles of veal).
- Lean meat should be roasted in a roasting tray **with a lid** (e.g. veal, braised beef, deep frozen meat). This keeps the juices in the meat.
- For cooking crispy crusts or bacon, a casserole **with no lid** should be used (e.g. pork, minced meat, lamb, mutton, duck, knuckle of veal, chicken, poultry meat, roast beef, fillet of beef, game birds).

## TIP:

- Clean the oven as soon as possible after use if you are roasting in an open-topped tin. It is easier to remove fat splashes when the oven is still warm, without using the pyrolytic self cleaning function.

**⚠ Warning:** Allow the oven to cool down enough to ensure there is no risk of burning yourself.

# Roasting

---

The table contains the required temperatures,roasting times and Oven levels for various kinds of meat. The figures stated are approximate figures only.

- We recommend cooking meat and fish weighing over 1 kg in the oven.
- For lean meat and fish, use Conventional heat. For all other kinds of meat we recommend Fan grill(  ) mode.
- Add a little liquid into the baking tray or deep pan to prevent roasting juices or fat from getting burned on.
- Turn the food over after about half or two thirds of the cooking time.

**TIP: For better roasting results,baste joints and poultry with their own juices a number of times during the roasting process.**

# Roasting tables

## Roasting Table

Food	Oven level	Fan grill – (1)		Conventional heat – (1)		Speed roast – (1)		Core Temp. (°C) (1)(3)(5)
		Temp. (°C) – (2)	Time (mins.)	Temp. (°C) – (2)	Time (mins.)	Temp. (°C) – (2)	Time (mins.)	
Beef (approx. 1kg)	24)	180	60~80	200	70~90	190	40~60	60~80
Venison (approx. 1kg)	24)	180	75~100	200~240	100~120	180	70~80	65~75
Leg of pork (approx. 1kg)	24)	185	75~100	200	100~120	180~190	70~90	80~90
Rolled pork (approx. 1kg)	24)	180~190	90~120	200~220	110~130	180~190	80~100	80~90
Leg of lamb (approx. 2kg)	2	180	110~130	200	150	180	90~110	80~85
Poultry (approx. 1kg)	24)	180~190	60~80	200~220	70~90	210	40~50	-
Poultry (approx. 2kg)	2	180~190	100~110	200~220	110~120	200	50~70	-
Stuffed	2	180~190	100~120	200~220	110~140	180~190	80~100	-
Poultry (approx. 4kg)	2	170~180	160~180	190~210	170~190	180~190	90~120	-
Whole fish (approx. 1.5kg)	24)	160~180	35~55	200~220	35~55	160~180	25~45	-

This table is intended as a guide only, individual tastes and cuts of meat will vary.

- 1) Fit the fat filter for roasting.
- 2) If pot roasting set the temperature 20°C higher.
- 3) Use the core temperature. Refer to the meat probe instructions.
- 4) Use the 4th level from the bottom when using Conventional heat.
- 5) Very rare:60~65°C, medium rare:65~75°C, medium:75~80°C, well done 80°C.

# Grilling

---

For grilling, you have a choice of 4 different operating modes.

## Large grill

For larger quantities of flat food for grilling, for top-baking in large tins. Choose 1 of 3 power levels (1 low, 2 medium and 3 high), as suitable for the food being grilled.

## Small grill

For smaller quantities of flat food for grilling, for top-baking in small tins. Choose 1 of 3 power levels (1 low, 2 medium and 3 high), as suitable for the food being grilled.

## Fan grill

For grilling larges pieces of meat or poultry, such as rolled roast or turkey.

## Speed grill

Use Speed grill function for rapid grilling.

In this mode, the halogen heating element is intermittently used on and the cooking time is reduced by about 20%.

**Note:** When grilling, the oven door must be kept closed at all times. As a basic principle, the oven should be preheated for 3 minutes!

## Grilling dishes

Use the grill tray or the deep pan for grilling. Use the wire grill for making toast. To catch dripping liquids, slide the baking tray or deep pan in at Level 1 or 2.

## Oven levels

Use levels 5 or 6 for grilling flat pieces of meat.

**⚠ Warning** : exposed parts of the oven can become hot during grilling. Keep children at a distance.

## Using the grilling table

The grilling times are intended as approximate values only. The actual times may vary depending on the quality of the actual meat or fish.

Grilling is particularly suitable for cooking flat pieces of meat and fish.

Turn the grilled food over about halfway through the cooking time.

## Grilling table

Food for grilling	Oven level	Large grill step 3		Speed grill	
		1st side	2nd side	1st side	2nd side
Rissoles	5	8–10 mins.	6–8 mins.	6–8 mins.	5–7 mins.
Pork fillet	5	10–12 mins.	6–10 mins.	8–10 mins.	5–8 mins.
Grilling sausages	5	8–10 mins.	6–8 mins.	6–8 mins.	5–7 mins.
Beef or veal steaks	5	6–7 mins.	5–6 mins.	4–6 mins.	4–5 mins.
Fillet of beef (1 kg approx.)	4	10–12 mins.	10–12 mins.	8–10 mins.	8–10 mins.
Toast <sup>1)</sup>	4	2–3 mins.	2–3 mins.	1–2 mins.	1–2 mins.
Toast with topping	4	6–8 mins.	–	4–6 mins.	–

1) Wire grill or deep pan

Always count the Oven levels from the bottom up.

# Defrosting

---

Use the "Defrost()" operating mode to defrost food.

## Defrosting dishes

- Remove the dish from its packaging, put it on a plate and place the plate on the wire grill.
- Do not cover the dish with a plate or bowl, as this can considerably extend the defrosting time.
- Do not use the liquid produced during defrosting for cooking the dish to avoid the risk of salmonella. Ensure that the liquid produced during defrosting is free to run off the food.

## Oven levels

- For defrosting, use the wire grill on Level 1, or Level 2 for larger dishes.

## Defrosting table

The following table contains reference values for defrosting.

Dish	Defrosting time (mins.)	Comments
Chicken, 1000 g	100–140	Use the wire grill with the deep pan. Turn the chicken after half of the time.
Meat, 1000 g	100–140	Turn the meat after half of the time or cover with tin foil.
Meat, 500 g	90–120	Turn the meat after half of the time or cover with tin foil.
Trout, 150 g	23–35	Do not cover.
Strawberries, 300 g	20–30	Do not cover.

# Special functions

---

You can set your oven to low temperatures from 40°C and up. This allows you to make yoghurt, for example, or to let dough rise.

## How to make yoghurt

### Dishes

Glasses or cups of 150 ml capacity which you cover with a lid or a piece of tin foil.

### Oven level

Place the wire grill on Level 4.

### Preparation

1. Heat 1 litre of milk to 60–70°C.
2. Leave the milk to cool to roughly 40°C.
3. Stir 150g of natural yoghurt into the milk, and then pour the mixture into the individual containers and cover.
4. Leave the individual containers on the wire grill for approx. 5–8 hours (until the yoghurt has reached a set consistency), mature in the oven with Conventional heat elements set at 40°C.

## How to raise yeast dough

### Dishes

Use a heat-resistant bowl for the dough (40°C).

### Oven level

Place the wire grill on Level 2.

### Preparation

1. Put the dough in the bowl. Cover the bowl with a damp cloth and place on the wire grill.
2. Switch on Conventional heat() mode at 40°C.
3. Leave the dough to rise until it has doubled in size.

# Cleaning and care

---

**⚠ Warning:** Switch the oven off before cleaning and allow to cool.

## Outside

Wipe the front of the appliance with a soft cloth using a mild detergent.

- Do not use any caustic or abrasive cleaning materials.
- For aluminium front panels use a mild window cleaner and for stainless steel front panels use the corresponding cleaner for stainless steel.

## Oven interior

### Note!

Clean the appliance after use, as soon as it has cooled down. This makes it easier to remove any deposits and they cannot get burnt on.

- Switch the oven light on.
- Wipe down the oven with water and dishwashing liquid. Allow to dry. Do not use any abrasive cleaners.
- Remove persistent deposits with a special oven cleaning product.

**Important:** When using a spray-on cleaner, it is essential to follow the manufacturer's instructions!

Do not clean the door seal by hand.

## Accessories

Clean the accessories (wire grill, baking tray, etc.) after use and allow to dry fully. If necessary, treat in advance to soften deposits.



# Pyrolytic cleaning

---

**⚠ Warning:** The surfaces of the oven become very hot during Pyrolytic cleaning. Accordingly, keep children away from the oven.

**NOTE:** before self cleaning, all accessories (wire grill, baking tray, deep pan, grill tray) must be taken out of the oven. Before proceeding, switch the oven off and allow to cool to an appropriate level.

Before self cleaning, larger deposits should be removed from the oven. Larger crumbs, fat and meat juices are flammable. These can cause the oven to catch fire during the self-cleaning process.

1. Select and confirm the “Manual cook”.
2. Select “Pyrolytic cleaning” and press the **Enter(✓) key**.
3. Depending on the degree of soiling, select and confirm the cleaning level.
4. On completion, the programme automatically switches off and a regular signal tone is heard.
5. Once the oven has cooled down, the remaining deposits can be wiped off with a damp cloth.

## **Length of self cleaning operation:**

Setting 1: approx. 75 minutes

Setting 2: approx. 95 minutes

Setting 3: approx. 120 minutes

**Important:** During self cleaning, the oven light is not switched on. For reasons of safety, the oven door is locked shut at a temperature of 250°C.

It is not unlocked until the temperature falls to 240°C.

# Oven light

## Risk of electric shock!

- Switch the oven off before replacing bulbs.
- Disconnect the appliance from the electricity supply

**Note :** To protect the bulbs and glass cover, a soft cloth should be placed on the oven floor.

## Replacing the oven light / cleaning the glass cover

### Step. 1

Remove the glass cover with the aid of a narrow, flat implement (e.g. tea-spoon) and clean it.

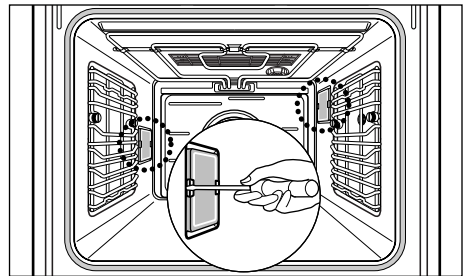

### Step. 2

Remove the defective halogen bulb by lifting it out.

Then replace it with a new one (20W, 12V, OSRAM).

**Note :** Always use a cloth or tissue to remove or fit a halogen light to avoid it burning on fatty deposits.

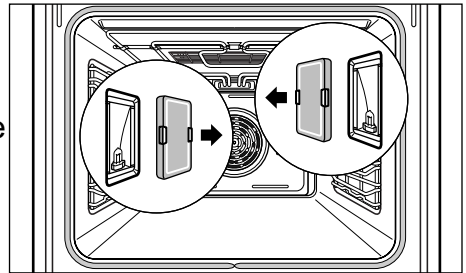

### Step. 3

Refit the glass cover.

**Note :** Make sure that all parts are correctly in place.

Both right and left side oven lamp can be replaced in an identical manner.

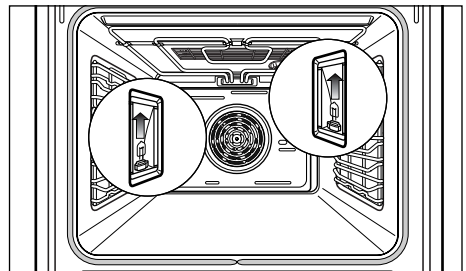

# Oven door

## Removing the oven door

### Step. 1

To remove the oven door for easier cleaning, open the door fully.

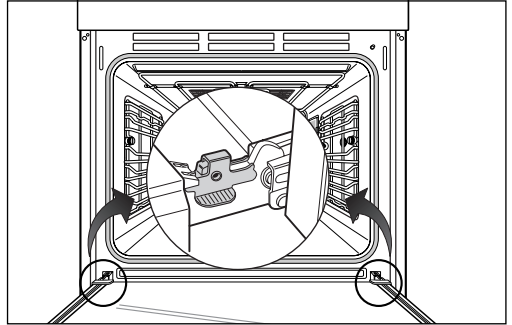

### Step. 2

To release the locking clamps on the hinges turn inner area of clamps upwards and outer area of them downwards as illustrated.

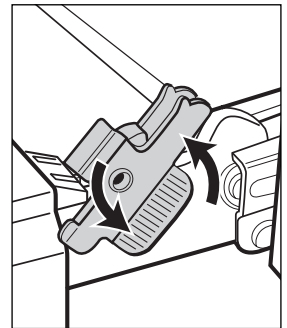
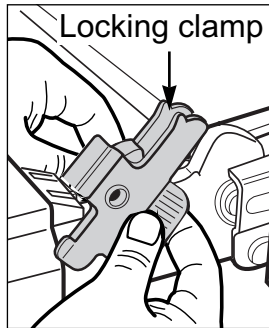

### Step. 3

Then lift the door upwards as far as it will go.

**Note :** Do not attempt to take the door off the hinge guides when it is in a horizontal position. The guides will close, and damage the appliance.

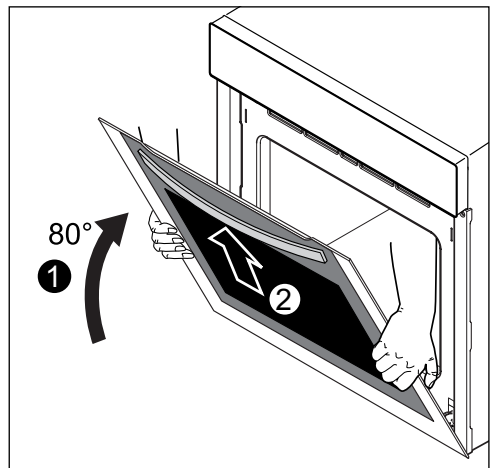

### Step. 4

Hold the door securely at both sides and lift upwards off the hinge guides.

# Oven door

## Rehanging the oven door

### Step. 1

Hold the door securely at both sides and carefully fit it back onto the hinge guides.

**Note :** Make sure that the door goes back on straight.

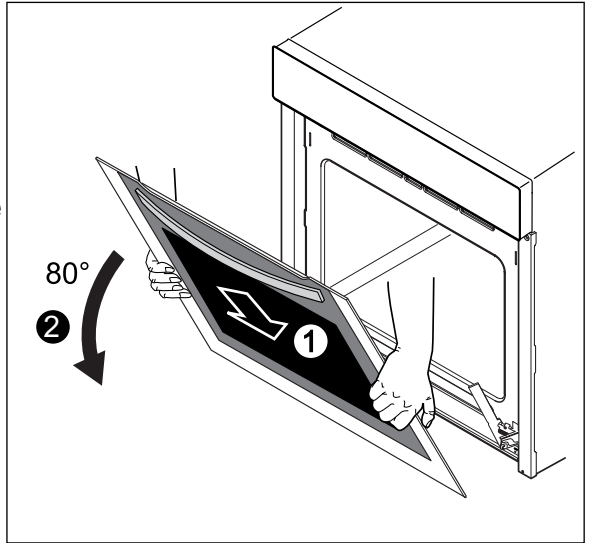

### Step. 2

Turn inner area of clamps downwards and outer area of them upwards as far as they will go into a horizontal position. Make sure that the notches on the locking clamps hook into the slots on the door as illustrated.

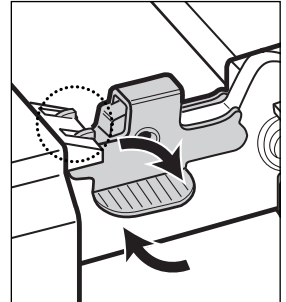
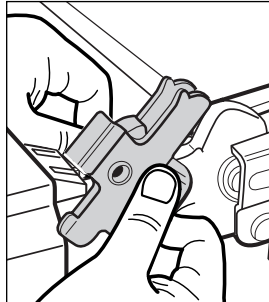

## Dismantling the oven door

The oven door is fitted with four glass panels, mounted one behind the other. The inner glass panels can be removed for cleaning.

**Note :** The following steps must be performed only after the oven door has been removed. Place the door on a soft and even surface with the handle facing down to protect it from breakage and to prevent it getting scratched.

### Step. 1

Remove the two screws at the right and left-hand side of the door and pull the top cover above the glass panels forward.

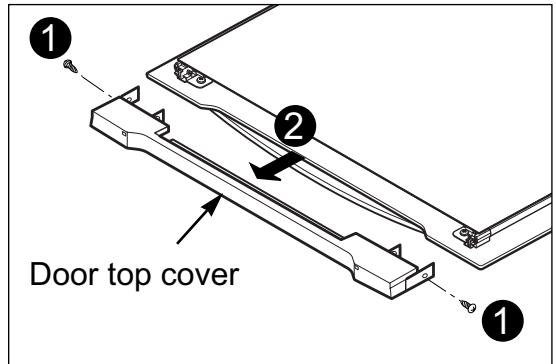

### Step. 2

Lift the innermost pane up and out from the door carefully. Then remove the insulator.

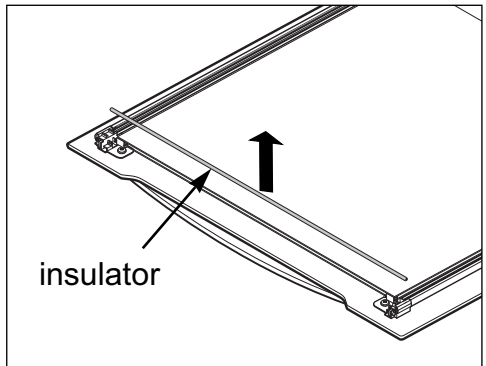
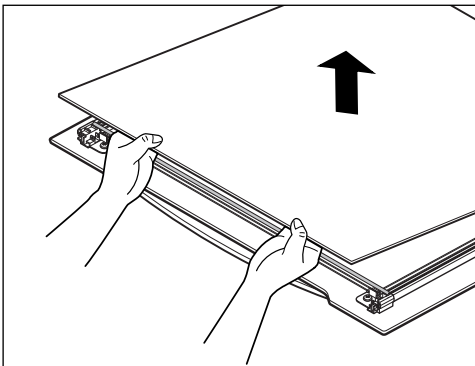

# Oven door

## Step. 3

Lift the second pane up and out. Then remove the spacer from the Door.

**Note :** Spacers are located next to the mount bracket to keep the Individual door panels in position.

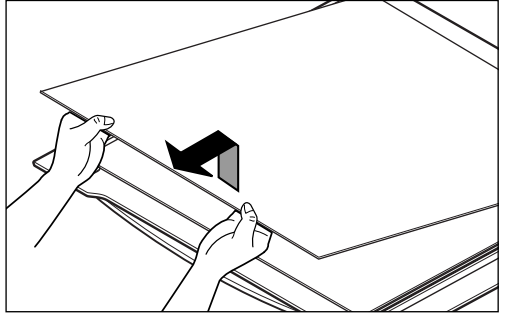

## Step. 4

Now the third pane can be removed.

Handle them very carefully to avoid the risk of breakage.

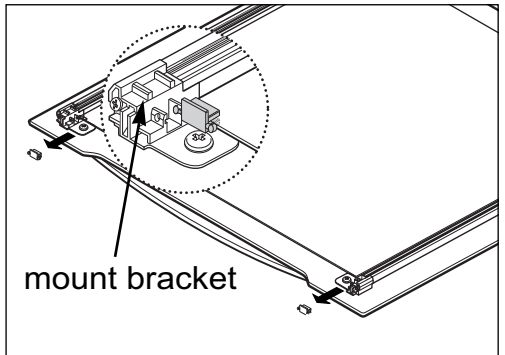

Door top cover

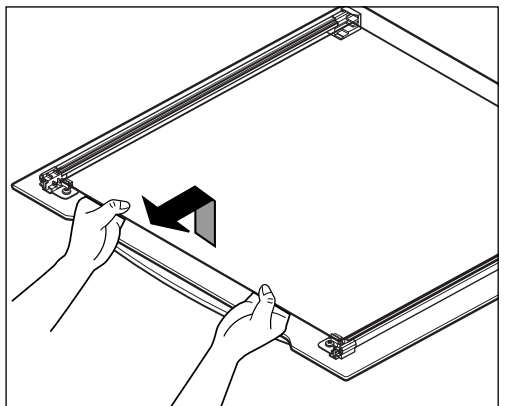
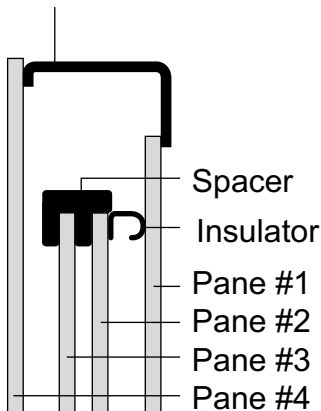

## Refitting the glass panels

### Step. 1

Refit the third pane and spacer. Then refit the second pane carefully.

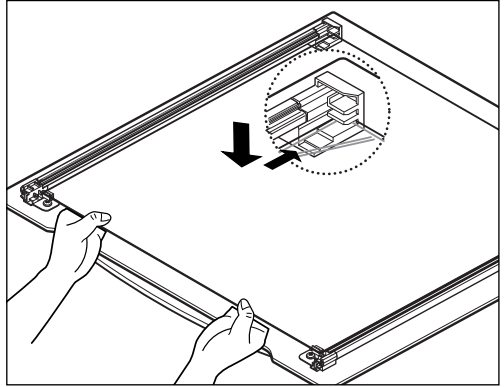

### Step. 2

Refit the black printed pane. The print should face in towards the middle pane.

**Note :** Individual panes must be located correctly in their retainers.

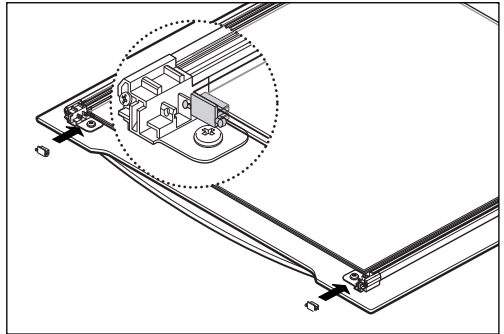

### Step. 3

Finally refit the top cover by securing the screws onto the door.

**Note :** Clean the glass panels with a mild detergent. Do not use harsh abrasive cleaners or sharp metal scrapers to clean the oven door glass since they can scratch the surface, which may result in shattering of the glass.

# Troubleshooting

<b>Fault</b>	<b>Possible cause</b>	<b>Solution</b>
The oven does not heat up.	The oven is not switched on.	Switch the oven on.
	The clock is not set.	Set the clock.
	The required settings have not been set.	Check the settings.
	Fault in the mains power supply. The protective electrical system or the fuses have been tripped.	Check out fuses and the protective system. If the fault recurs, consult a qualified electrician.
The oven does not heat up even after function and temperature are set.	An automatic programme has been set to run at a later time.	Cancel the settings or set them again.
The clock symbol flashes in the display.	There has been a power failure.	Set the current time on the clock display.
The oven lighting is not operating.	The oven bulb is faulty.	Change the oven bulb. See “Oven light” for details.
The meat probe does not work.	The meat probe not inserted correctly, or is faulty.	Check the meat probe socket.
Touch control function is poor to respond or intermittent.	Excessive grease or moisture build up on touch panel.	Clean touch panel with warm soapy water and dry off with a clean soft cloth.



---

**If the fault cannot be rectified by the above measures, contact your local Customer Service Centre.**

**Note!** If faulty, the appliance must not be used. If a fault occurs, the appliance must be isolated by removing the mains plug or switched off by removing the fuse.

The appliance must only be repaired by **a specially trained and qualified electrical professional only**. Repairs carried out improperly may result in considerable damage and void all warranties.

**Caution!** Repairs to the appliance must be carried out by a **specially licensed technician** only! Considerable danger may result from incorrect repairs and void all warranties.

**Caution!** Do not use the appliance if damaged. In the event of a fault or failure, switch off at the mains. In the event of a fault, visits by technicians from Customer Service or dealer may not be covered by guarantee, even during the warranty period, if the cause of failure is the result of abnormal customer use.

# Error codes

<b>Error Code</b>	<b>Possible Cause</b>	<b>Solution</b>
Oven thermistor short error	Sensor(Thermistor) is short.	Please contact the LG service center.
Oven thermistor open error	Sensor(Thermistor) is open. The door will be locked as if the oven is in self-cleaning mode.	Please contact the LG service center.
Door locking system error	Door Locking system is in troubled.	Shut off the power supply and reconnect the power. (wait a few minutes) If the door is unlocked, you can use the oven normally. But if the fault message appears again, please contact the LG service center.
Meat probe open error	Meat probe is not inserted.	Insert the meat probe plug into the socket or switch the oven off then switch it on again.
Meat probe short error	Meat probe is defective.	Replace the meat probe. But if the fault message appears again, please contact the LG service center.

# ***Technical specifications***

---

Mains connection                    220-240 V~ 50 Hz  
max. power consumption    3500 watt

## **Oven installation dimensions**

Height                                    min. 600  
Width                                    min. 560  
Depth                                    min. 556

## **Oven interior dimensions (mm)**

Height x width x depth        330 x 454 x 415  
Volume (useful capacity)    65L

# ***Technical specifications***

---

## **Regulations, standards and directives**

### **The appliance complies with the following standards:**

- EN 60335–1 and EN 60 335–2–6 (Safety of electrical appliances for use in the domestic household and for similar purposes).
- EN 60335 or DIN 44546 / 44547 / 44548 (Operating characteristics of electrical domestic cooking appliances, hot plates, ovens and grills).
- EN 55014–2 / VDE 0875 Part 14–2
- EN 55014-1 / VDE 0875 Part 14-1 / 1999–10
- EN 61000–3–2 / VDE 0838 Part 2
- EN 61000–3–3 / VDE 0838 Part 3 (Basic requirements in relation to electro-magnetic interference (EMI))

### **The appliance complies with the following EU directives:**

- 73/23/EEC issued 19.02.1973 (Low voltage), including supplement 90/683/EEC
- 89/336/EEC issued 03.05.1989 (EMI), including supplement 92/31/EEC
- 93/68/EWG (Identification marking)

# ***Installation instructions***

---

**Important:** installation should be undertaken by a qualified professional electrician only.

The oven must be installed in compliance with the manufacturer's instructions.

## **Safety instructions for the installer**

- During installation, ensure that no persons can come into contact with live components.
- The housing in which the oven is installed must comply with the stability requirements of the DIN 68930 standard.
- The oven must be installed by a qualified professional electrician, in accordance with the corresponding regulations and standards.
- The oven is a heavy appliance and must be transported with great care.
- Before initial use, remove all packaging, both external and from inside the appliance.
- No modification may be made to the oven's technical characteristics.
- The integrated cooking area or hotplates is/are provided with special connections. These may only be attached to the appropriate corresponding connections of the same type.

# ***Customer service & spare parts***

---

If you require spare parts or a technician, contact your local LG Customer Service Centre.

Your call will be automatically passed on to the Customer Service Centre responsible for your post code area. You can find the address of your local Customer Service Centre and other information for customers on the Internet at [www.lge.com](http://www.lge.com)

Please ensure you have the following details to hand:

1. Your name and address, including your post code.
2. Your telephone number.
3. Exact details of the nature of the problem.
4. The model, series and serial number. These details are found on the rating plate located at the left-hand inner edge of the oven door.
5. Your dated receipt of purchase. Please note that proof of purchase is required for any guarantee claim. Before submitting a guarantee claim, please ensure that you have read through the section on “Troubleshooting”. There will be a charge for any inspection carried out by a technician if it should transpire that there is no mechanical or electrical fault present in the appliance.

## **Customer Service**

For general queries on LG appliances or further details of LG products, please contact our Customer Service Centre in writing or by telephone or visit our website at [www.lgservice.com](http://www.lgservice.com)

# Warranty

The model, serial and production number are on the rating plate. These information can be found on the rating plate. The rating plate is on the left side of the door. Rating plate is located on the left side of door and the cover-back.

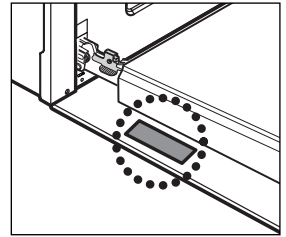

## REQUIREMENTS TO MAINTAIN WARRANTY COVERAGE:

RETAIN YOUR RECEIPT TO PROVE DATE OF PURCHASE. A COPY OF YOUR RECEIPT MUST BE SURRENDERED AT THE TIME GUARANTEE SERVICE IS PROVIDED.

## PRODUCT REGISTRATION CARD:

It is helpful to complete at least, your name, address, phone, model & serial numbers and return it. This will enable LG Electronics to assist you in the future should you lose your receipt, your units stolen, or should modification be necessary.

## To obtain information or assistance:

MODEL	SERIAL# *	DATE OF PURCHASE

## \*Please complete for your own record

In all cases of difficulty - consult your LG dealer from whom the product was purchased.

