



Dome Camera Owner's Manual

MODEL: LT303

Before installing and using the camera, please read this owner's manual carefully and retain for future reference.





CAUTION
RISK OF ELECTRIC SHOCK
DO NOT OPEN



CAUTION: TO REDUCE THE RISK OF ELECTRIC SHOCK DO NOT REMOVE COVER (OR BACK) NO USER-SERVICEABLE PARTS INSIDE REFER SERVICING TO QUALIFIED SERVICE PERSONNEL.



This lightning flash with arrowhead symbol within an equilateral triangle is intended to alert the user to the presence of uninsulated dangerous voltage within the product's enclosure that may be of sufficient magnitude to constitute a risk of electric shock to persons.



The exclamation point within an equilateral triangle is intended to alert the user to the presence of important operating and maintenance (servicing) instructions in the literature accompanying the product.

FCC WARNING : This equipment may generate or use radio frequency energy. Changes or modifications to this equipment may cause harmful interference unless the modifications are expressly approved in the instruction manual. The user could lose the authority to operate this equipment if an unauthorized change or modification is made.

REGULATORY INFORMATION: FCC Part 15

This equipment has been tested and found to comply with the limits for a Class A digital device, pursuant to Part 15 of the FCC Rules. These limits are designed to provide reasonable protection against harmful interference when the equipment is operated in a commercial environment.

This equipment generates, uses, and can radiate radio frequency energy and, if not installed and used in accordance with the instruction manual, may cause harmful interference to radio communications.

Operation of this equipment in a residential area is likely to cause harmful interference in which case the user will be required to correct the interference at his own expense.

- A suitable conduit entries, knock-outs or glands shall be provided in the cable entries of this product in the end user.
- Caution: Danger of explosion if battery is incorrectly replaced. Replaced only with the same or equivalent type recommended by the manufacturer. Dispose of used batteries according to the manufacturer's instructions.
- Holes in metal, through which insulated wires pass, shall have smooth well rounded surfaces or shall be provided with brushings.

Warning: Do not install this equipment in a confined space such as a bookcase or similar unit.

Warning: Wiring methods shall be in accordance with the National Electric Code, ANSI/NFPA 70.

Warning: This is a class A product. In a domestic environment this product may cause radio interference in which case the user may be required to take adequate measures.

Warning: To reduce a risk of fire or electric shock, do not expose this product to rain or moisture.

Caution: This installation should be made by a qualified service person and should conform to all local codes.

Caution: To avoid electrical shock, do not open the cabinet. Refer servicing to qualified personnel only.

Caution: The apparatus shall not be exposed to water (dripping or splashing) and no objects filled with liquids, such as vases, shall be placed on the apparatus.



Disposal of your old appliance

1. When this crossed-out wheeled bin symbol is attached to a product it means the product is covered by the European Directive 2002/96/EC.
2. All electrical and electronic products should be disposed of separately from the municipal waste stream via designated collection facilities appointed by the government or the local authorities.
3. The correct disposal of your old appliance will help prevent potential negative consequences for the environment and human health.
4. For more detailed information about disposal of your old appliance, please contact your city office, waste disposal service or the shop where you purchased the product.



This product is manufactured to comply with EMC Directive 2004/108/EC and Low Voltage Directive 2006/95/EC.

European representative:

LG Electronics Service Europe B.V.
Veluwezoom 15, 1327 AE Almere, The Netherlands
(Tel : +31-036-547-8940)

Important Safety Instructions

1. **Read these instructions.**
2. **Keep these instructions.**
3. **Heed all warnings.**
4. **Follow all instructions.**
5. **Do not use this apparatus near water.**
6. **Clean only with dry cloth.**
7. **Do not block any ventilation openings. Install in accordance with the manufacturer's instructions.**
8. **Do not install near any heat sources such as radiators, heat registers, stoves, or other apparatus (including amplifiers) that produce heat.**
9. **Do not defeat the safety purpose of the polarized or grounding-type plug. A polarized plug has two blades with one wider than the other. A grounding type plug has two blades and a third grounding prong. The wide blade or the third prong are provided for your safety. If the provided plug does not fit into your outlet, consult an electrician for replacement of the obsolete outlet.**
10. **Protect the power cord from being walked on or pinched particularly at plugs, convenience receptacles, and the point where they exit from the apparatus.**
11. **Only use attachments/accessories specified by the manufacturer.**
12. **Use only with the cart, stand, tripod, bracket, or table specified by the manufacturer, or sold with the apparatus. When a cart is used, use caution when moving the cart/apparatus combination to avoid injury from tip-over.**



13. **Unplug this apparatus during lightning storms or when unused for long periods of time.**
14. **Refer all servicing to qualified service personnel. Servicing is required when the apparatus has been damaged in any way, such as power-supply cord or plug is damaged, liquid has been spilled or objects have fallen into the apparatus, the apparatus has been exposed to rain or moisture, does not operate normally, or has been dropped.**

Contents

Reference	29
Specifications.....	29

Introduction..... 5

About Dome Camera	5
Features.....	5
Safety Precautions.....	6
Identification of Camera.....	7

Installation..... 8

Installation Precautions.....	8
Removing the Protection Tape.....	8
Mounting the Camera	9
Dipswitch Setting	11
Camera ID Setting	12

Connections..... 15

Precautions.....	15
Connection preview	15
RS-485 connection	15
Connecting monitor.....	15
Connecting power source	15
ALARM IN connections.....	15
Connecting LKD1000 controller.....	17
System Connection.....	18

Operation..... 19

Setup Menu Overview	19
Menu navigation	20
General Operation	21
Focus setting	21
Exposure settings	23
White Balance setting	24
Day/Night setting	25
Motion Detection setting	25
Privacy Mask setting.....	26
3D-DNR setting.....	26
Special menu settings.....	26
Language setting	28
Reset settings	28

Introduction

About Dome Camera

The dome cameras are designed for installation in an indoor or outdoor video surveillance system.

The camera incorporates the digital signal processor, pan/tilt mechanism, x27 zoom lens and RS-485 communication interface in a compact outdoor enclosure.

Features

- **High Sensitivity Support**
The camera provides the high quality picture with 1/4" EX-view HAD CCD.
- **Preset Position**
Preset position is the function to register camera monitoring positions (preset positions). By using LKD1000 controller, you can register presets with position number. Maximum 128 Preset Position are available. By entering the position numbers, you can move cameras to the preset positions. The moving speed and holding time are adjustable.
- **Preset Tour**
Preset Tour is the function to go through all the registered camera monitoring positions (preset positions).
- **Preset Group Tour**
A preset tour is composed of a group of preset positions that the operator can program to be linked together in a sequence. A preset group should have a maximum of 8 preset positions.
- **Pattern recording function**
A routine of manual operations can be stored and reproduced repeatedly. The Pan, Tilt and Zoom controls are available for pattern recording.
Note:
The available total time of pattern differs depending on camera's operation. When the pattern recording is full, the pattern recording will automatically stop.
- **Privacy Mask**
Privacy zone feature enables users to veil unwanted zones. This setting is used for masking unwanted zones, hiding them from display on the monitor screen. Up to 8 zones can be registered.
- **Auto Pan**
The camera has an Auto Pan function that enables to keep surveillance on every detail occurring around the specific area, which is preset to watch in advance.
The camera can pan among the maximum 8 points you will set. The moving speed and holding time are adjustable.
- **Auto Flip**
When the camera is operated to tilt through the 90°, it can be watched the opposite side of the locations by Auto Flip of a 180° horizontally.
- **Optical Zoom**
The optical zoom range is 1x to 27x.
- **Digital Zoom**
Digital zoom enhances the systems zoom range to 12 times beyond the 27x optical zoom limit. By utilizing the digital zoom function, the total system zoom range increases further from 27x (1x digital zoom) to 324x (12x digital zoom)
- **Sensor Linkage**
The camera is capable of capturing a subject by the focus of camera moving promptly toward the subject at the rate of 120°/sec when the camera works with a detector (magnetic, beam, infrared rays), and a subject moving within a detection area is captured by a detector.
- **Alarm In function**
Alarm input signals are supplied from external devices through the ALARM IN connector to activate 'go to preset' function.
- **Controls by General Controller**
This camera can be controlled by RS-485. Especially the camera has an excellent cost-saving effect because it can be controlled by the general RX point of contact signal.
- **Connects with the maximum 256 cameras**
This camera can be utilized after being connected with maximum 256 cameras.
Therefore, it is capable of performing an excellent job in the large buildings or department stores.

- **Day & Night Function**
This camera can be selected Color or Black & White. You can set Color in the daytime and Black & White at night due to the low illumination. (Filter Conversion type)
- **DSS (Digital Slow Shutter) function**
It is possible to highly sensitive surveillance because of DSS(Digital Slow Shutter) function.
- **WDR (Wide Dynamic Range) function**
The camera can be best condition to watch easily inside or outside in the strong back light.
- **Power Supply**
This camera must always be operated a DC 12V Certified/Listed, class 2 power supply only.

Safety Precautions

- **Do not attempt to disassemble the camera**
To prevent electric shock, do not remove screws or covers. There are no user serviceable parts inside. Ask a qualified service personnel for servicing.
- **Avoid the camera with direct sunlight**
Do not aim the camera at bright objects. Whether the camera is in use or not, never face it with direct sunlight or other extremely bright objects. Otherwise blooming or smear may be caused.
- **Handle the camera with care**
Do not abuse the camera. Avoid striking, shaking, etc. The camera could be damaged by improper handling or storage.
- **Do not use strong solvents or detergents**
Use a dry cloth to the camera when it is dirty. If it is hard to remove the dirt on the camera, use a mild detergent and wipe it gently.
- **Do not install this camera upside down**
This camera is designed for mounting on the ceiling or wall. If you install this camera upside down, for example, mounted on the floor, it may cause malfunction.
- **Do not use the camera in such places as shown below.**
The lens may become cloudy due to condensation if the camera is used under the following conditions.
 - Rapid temperature fluctuation by switching an air conditioner on and off.

- Rapid temperature fluctuation due to frequent door opening and closing.
- Use in an environment where eyeglasses become foggy.
- Use in a room filled with cigarette smoke or dust.
If the lens becomes cloudy due to condensation, remove the dome cover and wipe all moist surfaces with a soft cloth.
- **Before operating, please check proper temperature, humidity and power source ratings.**
Use the camera under conditions where temperature is between -10~50 °C and humidity is below 80%. The input power source is DC 12V.
- **Consumables**
Parts having contacts such as the lens-drive motors, cooling fan built inside the camera are subject to wear with time. About replacement and maintenance of such parts, please ask the nearest service center.

Identification of Camera

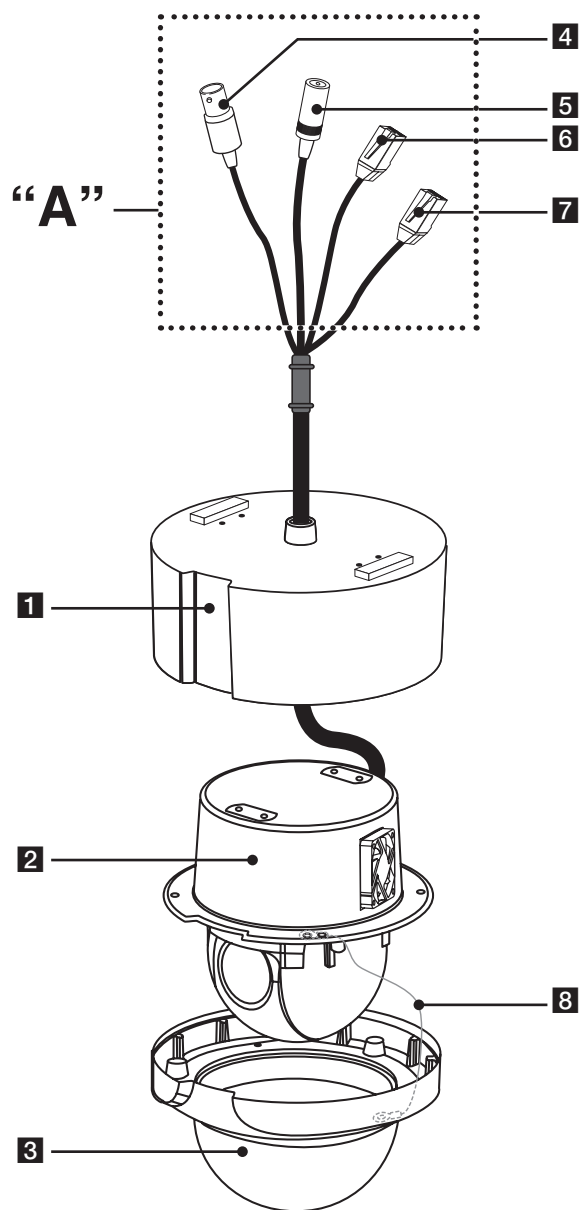

- 1** Camera mounting bracket
- 2** Dome camera body
- 3** Dome cover assembly
- 4** Video output cable with BNC connector
Connects with the video connector of the monitor.
- 5** Power cable (DC 12V)
- 6** Data Communication Port (RJ45) - RS-485 and Alarm Input
- 7** Data Communication Port (RJ45) - RS-485 and Alarm Input
- 8** Fall Prevention Wire

Be sure to hook the fall prevention wire into a bracket.

Caution:

When you fix the dome cover to the dome camera body, you must insert the wire in the dome camera body. If not, the wire may obstruct the camera's moving.

“A” Do not expose the power and data cable to moisture, this may cause leakage into the housing and damage the camera. If you must, please make sure that the connections are sealed tightly. After installing the camera, you should arrange the cables using the outlet box to protect the cables.

Installation

Installation Precautions

The following steps of installation and connection work should be done by qualified service personnel or system installers and should conform to all local codes.

Before you install and connect the camera, check and prepare the required peripheral devices and cables.

Before you connect the camera, turn off all devices to be connected, such as this camera and DVR.

Note:

Do not touch the dome cover's window.

Camera Installation Location

Discuss the installation location for the camera with your retailer, and select a place that is strong enough for the installation.

- Install the camera on a ceiling (concrete, etc.) at a location that is sufficiently strong to support it.
- Install the camera body on the foundation section of the building or sections having sufficient bearing strength.

Never install or use the camera in the following locations

- Do not install it in areas exposed to direct sunlight or rain.
- Do not install the camera near the air outlet of an air conditioner.
- Near a swimming pool or other areas where chemicals are used.
- Food preparation areas and other locations where there are large amounts of steam vapor and oil, in flammable atmospheres, other special environments.
- Areas where radiation, X-rays, strong electric waves, or magnetism is generated.
- At sea, in coastal areas, or in areas where corrosive gas is being generated.
- Areas outside of the allowable ambient operating temperature range
- When installing the camera on a ceiling of insufficient strength, reinforce the ceiling.

About Static Electricity Removal

Before installing the camera, touch a metal case or other metallic parts with your hand to remove static electricity from your body.

Do not install in areas subjected to high amounts of humidity or dust.

Doing so may cause internal components to damage more easily or malfunction.

Do not wire cables near power lines.

Tightening the Screws

Screws should be tightened sufficiently in accordance with the materials and structure of the installation location. After tightening the screws, visually inspect them to make sure there is no unevenness and that each screw is tight.

Removing the Protection Tape

Before using the camera, remove the protection tape.

Caution:

Remove the protection tape carefully.

1. Loosen the screws using the wrench and remove the dome cover as shown below.

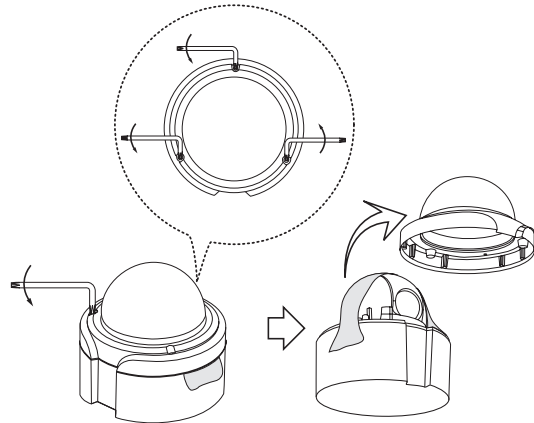

2. Remove the protection tape and attach the dome cover.

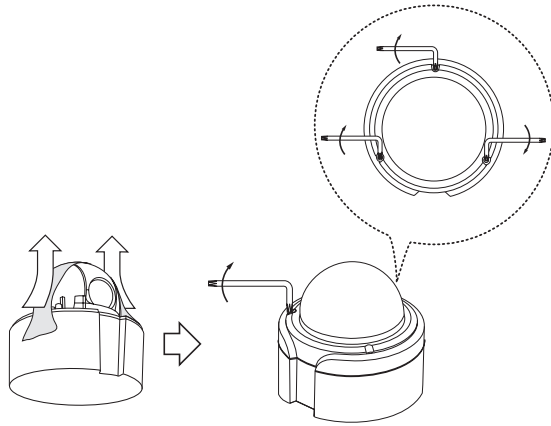

Note:

When you install the camera to the ceiling mount, you must drill a hole in the camera body as shown right. (ø5.0)

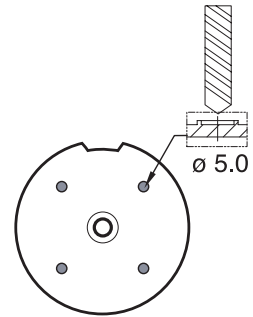

Mounting the Camera

The figures show an example of the camera mounted on a ceiling or wall with a locally procured bracket.

Note:

The camera have not been evaluated for wall or ceiling mounting.

Surface mount

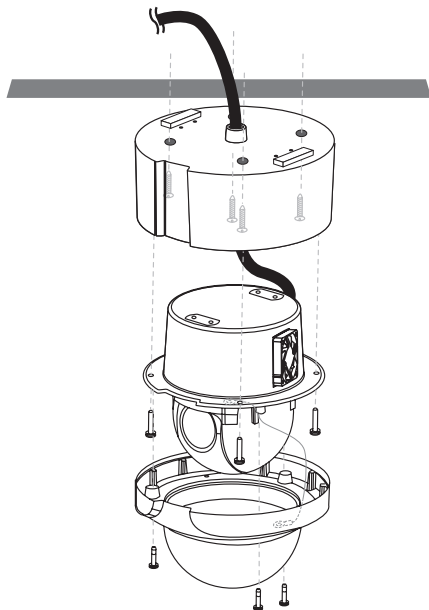

Pendant mount (Optional)

Install pipe and camera as shown below.

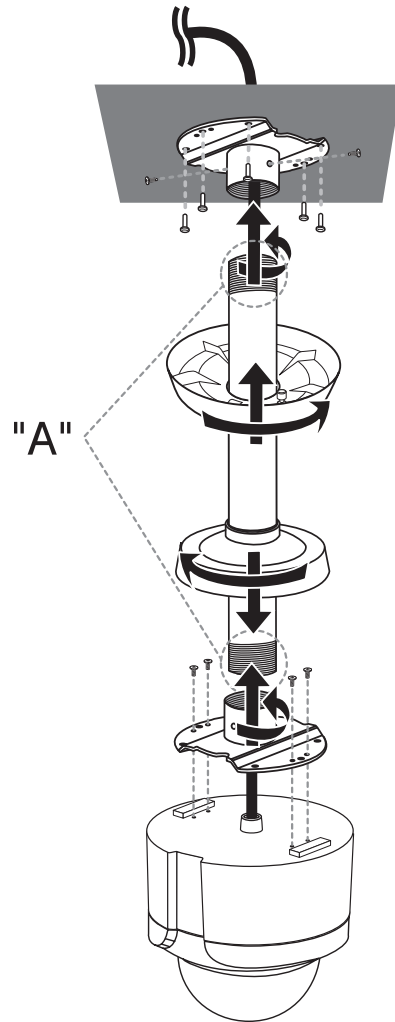

Wall mount (Optional)

Install the camera in the following order.

1. Drill holes on the wall where you want to install the pipe.
2. Install the pipe and camera as shown below.

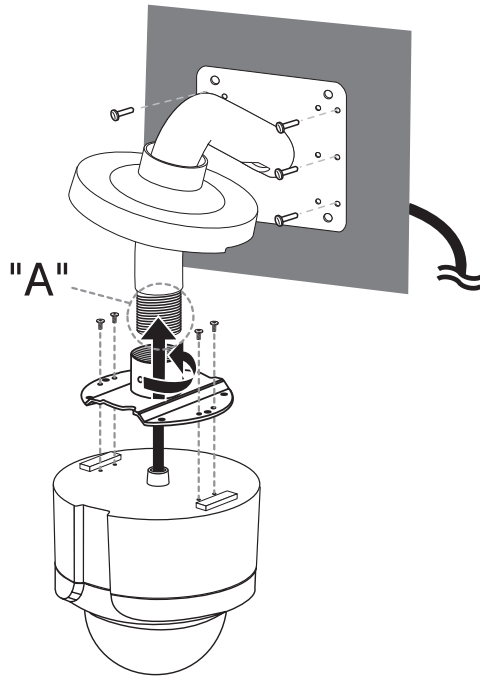

Note:

Do not remove the block (A) to keep the gap (B) between the camera body and installation bracket.

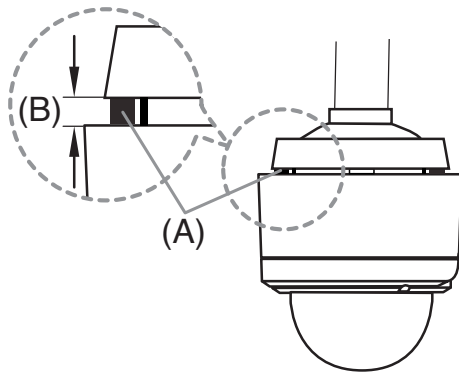

How to install

“A” Pipe threads should be clean and rust free. Use a sealer (such as Teflon™ tape and silicone sealer) on the threads.

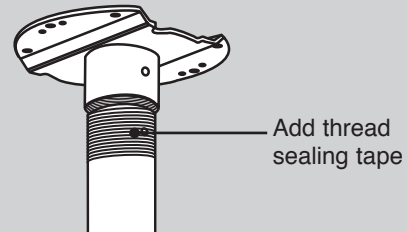

Note:

The pipes and brackets for mounting are not supplied.

Reference: Specifications of LG Standard pipe.

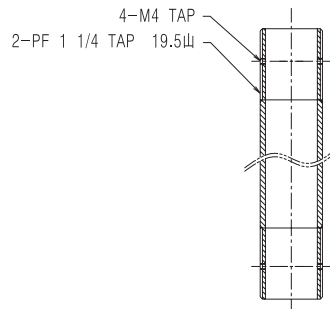

Dipswitch Setting

The camera has one 4 bit switches that determine the protocol and baud rate of the data communication. Settings are loaded when the camera boots up. Be sure to turn the camera off, change the dipswitch settings, then power back up to load the changes.

1. Turn off the camera.
2. Remove the dome cover from the housing.
3. Set the dipswitches inside the housing as per the table below.
4. Power up the camera to load the changes.

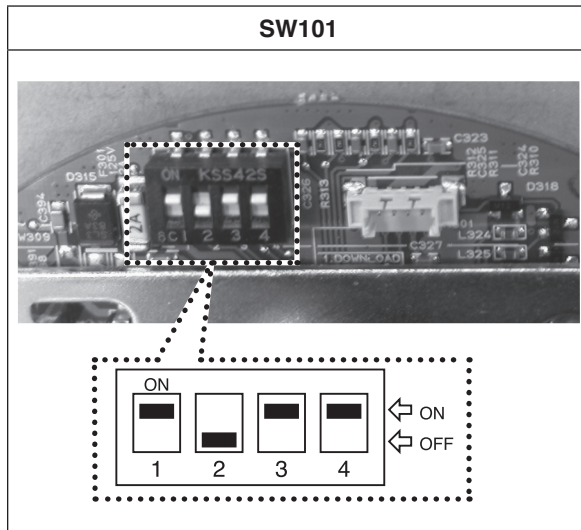







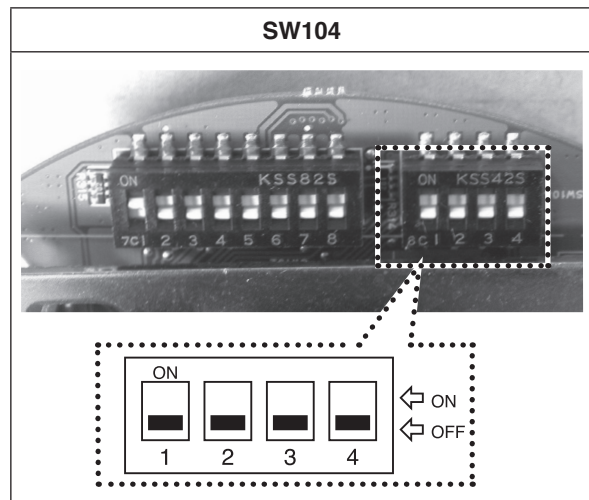

Switch position (SW101)	Protocol
(ON ON ON ON)	Reserved 1
(ON OFF ON ON)	LG Multix
(OFF ON ON ON)	Pelco D
(OFF OFF ON ON)	Pelco P
(ON ON OFF ON)	Reserved 2
(OFF ON OFF ON)	Reserved 3

(ON OFF OFF ON)	Reserved 4
(OFF OFF OFF ON)	Reserved 5
(ON ON ON OFF)	Reserved 6
(OFF ON ON OFF)	Reserved 7
(ON OFF ON OFF)	Reserved 8
(OFF OFF ON OFF)	Reserved 9
(ON ON OFF OFF)	Reserved 10
(OFF ON OFF OFF)	Reserved 11
(ON OFF OFF OFF)	Reserved 12
(OFF OFF OFF OFF)	Reserved 13

Note:

If you are not using the controller with LG Multix protocol, there may be some limitation of function control.

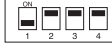

Switch position (SW104)	Baud Rate
 (OFF OFF OFF OFF)	9,600 BPS
 (OFF OFF OFF ON)	1,200 BPS
 (OFF OFF ON OFF)	2,400 BPS
 (OFF OFF ON ON)	4,800 BPS
 (OFF ON OFF OFF)	19,200 BPS
 (OFF ON OFF ON)	38,400 BPS
 (OFF ON ON OFF)	57,600 BPS
 (OFF ON ON ON)	115,200 BPS

Camera ID Setting

If you want to use multiple cameras, you should set camera IDs differently by using the 8-bit Dip switch for each camera.

Set the camera ID setting referring to the pictures and the table on the below.

- The default setting of the camera ID is 1.

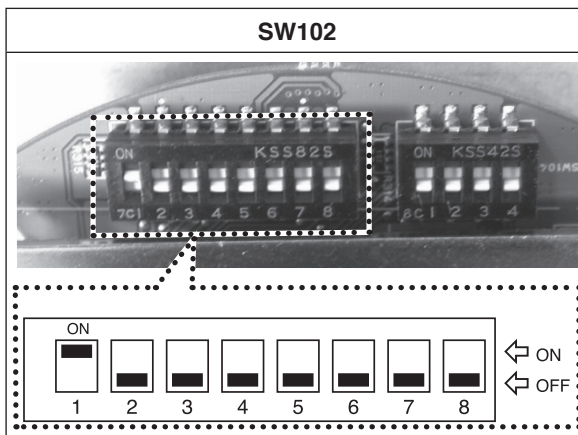

The table for the camera ID setting

ID	SW1	SW2	SW3	SW4	SW5	SW6	SW7	SW8
0	OFF	OFF	OFF	OFF	OFF	OFF	OFF	OFF
1	ON	OFF	OFF	OFF	OFF	OFF	OFF	OFF
2	OFF	ON	OFF	OFF	OFF	OFF	OFF	OFF
3	ON	ON	OFF	OFF	OFF	OFF	OFF	OFF
4	OFF	OFF	ON	OFF	OFF	OFF	OFF	OFF
5	ON	OFF	ON	OFF	OFF	OFF	OFF	OFF
6	OFF	ON	ON	OFF	OFF	OFF	OFF	OFF
7	ON	ON	ON	OFF	OFF	OFF	OFF	OFF
8	OFF	OFF	OFF	ON	OFF	OFF	OFF	OFF
9	ON	OFF	OFF	ON	OFF	OFF	OFF	OFF
10	OFF	ON	OFF	ON	OFF	OFF	OFF	OFF
11	ON	ON	OFF	ON	OFF	OFF	OFF	OFF
12	OFF	OFF	ON	ON	OFF	OFF	OFF	OFF
13	ON	OFF	ON	ON	OFF	OFF	OFF	OFF
14	OFF	ON	ON	ON	OFF	OFF	OFF	OFF
15	ON	ON	ON	ON	OFF	OFF	OFF	OFF
16	OFF	OFF	OFF	OFF	ON	OFF	OFF	OFF
17	ON	OFF	OFF	OFF	ON	OFF	OFF	OFF
18	OFF	ON	OFF	OFF	ON	OFF	OFF	OFF
19	ON	ON	OFF	OFF	ON	OFF	OFF	OFF
20	OFF	OFF	ON	OFF	ON	OFF	OFF	OFF
21	ON	OFF	ON	OFF	ON	OFF	OFF	OFF
22	OFF	ON	ON	OFF	ON	OFF	OFF	OFF
23	ON	ON	ON	OFF	ON	OFF	OFF	OFF
24	OFF	OFF	OFF	ON	ON	OFF	OFF	OFF
25	ON	OFF	OFF	ON	ON	OFF	OFF	OFF
26	OFF	ON	OFF	ON	ON	OFF	OFF	OFF
27	ON	ON	OFF	ON	ON	OFF	OFF	OFF
28	OFF	OFF	ON	ON	ON	OFF	OFF	OFF
29	ON	OFF	ON	ON	ON	OFF	OFF	OFF
30	OFF	ON	ON	ON	ON	OFF	OFF	OFF
31	ON	ON	ON	ON	ON	OFF	OFF	OFF
32	OFF	OFF	OFF	OFF	OFF	ON	OFF	OFF
33	ON	OFF	OFF	OFF	OFF	ON	OFF	OFF
34	OFF	ON	OFF	OFF	OFF	ON	OFF	OFF
35	ON	ON	OFF	OFF	OFF	ON	OFF	OFF
36	OFF	OFF	ON	OFF	OFF	ON	OFF	OFF
37	ON	OFF	ON	OFF	OFF	ON	OFF	OFF
38	OFF	ON	ON	OFF	OFF	ON	OFF	OFF
39	ON	ON	ON	OFF	OFF	ON	OFF	OFF
40	OFF	OFF	OFF	ON	OFF	ON	OFF	OFF
41	ON	OFF	OFF	ON	OFF	ON	OFF	OFF
42	OFF	ON	OFF	ON	OFF	ON	OFF	OFF
43	ON	ON	OFF	ON	OFF	ON	OFF	OFF
44	OFF	OFF	ON	ON	OFF	ON	OFF	OFF
45	ON	OFF	ON	ON	OFF	ON	OFF	OFF
46	OFF	ON	ON	ON	OFF	ON	OFF	OFF
47	ON	ON	ON	ON	OFF	ON	OFF	OFF
48	OFF	OFF	OFF	OFF	ON	ON	OFF	OFF
49	ON	OFF	OFF	OFF	ON	ON	OFF	OFF
50	OFF	ON	OFF	OFF	ON	ON	OFF	OFF
51	ON	ON	OFF	OFF	ON	ON	OFF	OFF
52	OFF	OFF	ON	OFF	ON	ON	OFF	OFF
53	ON	OFF	ON	OFF	ON	ON	OFF	OFF
54	OFF	ON	ON	OFF	ON	ON	OFF	OFF
55	ON	ON	ON	OFF	ON	ON	OFF	OFF
56	OFF	OFF	OFF	ON	ON	ON	OFF	OFF
57	ON	OFF	OFF	ON	ON	ON	OFF	OFF
58	OFF	ON	OFF	ON	ON	ON	OFF	OFF
59	ON	ON	OFF	ON	ON	ON	OFF	OFF
60	OFF	OFF	ON	ON	ON	ON	OFF	OFF
61	ON	OFF	ON	ON	ON	ON	OFF	OFF

62	OFF	ON	ON	ON	ON	ON	OFF	OFF
63	ON	ON	ON	ON	ON	ON	OFF	OFF
64	OFF	OFF	OFF	OFF	OFF	OFF	ON	OFF
65	ON	OFF	OFF	OFF	OFF	OFF	ON	OFF
66	OFF	ON	OFF	OFF	OFF	OFF	ON	OFF
67	ON	ON	OFF	OFF	OFF	OFF	ON	OFF
68	OFF	OFF	ON	OFF	OFF	OFF	ON	OFF
69	ON	OFF	ON	OFF	OFF	OFF	ON	OFF
70	OFF	ON	ON	OFF	OFF	OFF	ON	OFF
71	ON	ON	ON	OFF	OFF	OFF	ON	OFF
72	OFF	OFF	OFF	ON	OFF	OFF	ON	OFF
73	ON	OFF	OFF	ON	OFF	OFF	ON	OFF
74	OFF	ON	OFF	ON	OFF	OFF	ON	OFF
75	ON	ON	OFF	ON	OFF	OFF	ON	OFF
76	OFF	OFF	ON	ON	OFF	OFF	ON	OFF
77	ON	OFF	ON	ON	OFF	OFF	ON	OFF
78	OFF	ON	ON	ON	OFF	OFF	ON	OFF
79	ON	ON	ON	ON	OFF	OFF	ON	OFF
80	OFF	OFF	OFF	OFF	ON	OFF	ON	OFF
81	ON	OFF	OFF	OFF	ON	OFF	ON	OFF
82	OFF	ON	OFF	OFF	ON	OFF	ON	OFF
83	ON	ON	OFF	OFF	ON	OFF	ON	OFF
84	OFF	OFF	ON	OFF	ON	OFF	ON	OFF
85	ON	OFF	ON	OFF	ON	OFF	ON	OFF
86	OFF	ON	ON	OFF	ON	OFF	ON	OFF
87	ON	ON	ON	OFF	ON	OFF	ON	OFF
88	OFF	OFF	OFF	ON	ON	OFF	ON	OFF
89	ON	OFF	OFF	ON	ON	OFF	ON	OFF
90	OFF	ON	OFF	ON	ON	OFF	ON	OFF
91	ON	ON	OFF	ON	ON	OFF	ON	OFF
92	OFF	OFF	ON	ON	ON	OFF	ON	OFF
93	ON	OFF	ON	ON	ON	OFF	ON	OFF
94	OFF	ON	ON	ON	ON	OFF	ON	OFF
95	ON	ON	ON	ON	ON	OFF	ON	OFF
96	OFF	OFF	OFF	OFF	OFF	ON	ON	OFF
97	ON	OFF	OFF	OFF	OFF	ON	ON	OFF
98	OFF	ON	OFF	OFF	OFF	ON	ON	OFF
99	ON	ON	OFF	OFF	OFF	ON	ON	OFF
100	OFF	OFF	ON	OFF	OFF	ON	ON	OFF
101	ON	OFF	ON	OFF	OFF	ON	ON	OFF
102	OFF	ON	ON	OFF	OFF	ON	ON	OFF
103	ON	ON	ON	OFF	OFF	ON	ON	OFF
104	OFF	OFF	OFF	ON	OFF	ON	ON	OFF
105	ON	OFF	OFF	ON	OFF	ON	ON	OFF
106	OFF	ON	OFF	ON	OFF	ON	ON	OFF
107	ON	ON	OFF	ON	OFF	ON	ON	OFF
108	OFF	OFF	ON	ON	OFF	ON	ON	OFF
109	ON	OFF	ON	ON	OFF	ON	ON	OFF
110	OFF	ON	ON	ON	OFF	ON	ON	OFF
111	ON	ON	ON	ON	OFF	ON	ON	OFF
112	OFF	OFF	OFF	OFF	ON	ON	ON	OFF
113	ON	OFF	OFF	OFF	ON	ON	ON	OFF
114	OFF	ON	OFF	OFF	ON	ON	ON	OFF
115	ON	ON	OFF	OFF	ON	ON	ON	OFF
116	OFF	OFF	ON	OFF	ON	ON	ON	OFF
117	ON	OFF	ON	OFF	ON	ON	ON	OFF
118	OFF	ON	ON	OFF	ON	ON	ON	OFF
119	ON	ON	ON	OFF	ON	ON	ON	OFF
120	OFF	OFF	OFF	ON	ON	ON	ON	OFF
121	ON	OFF	OFF	ON	ON	ON	ON	OFF
122	OFF	ON	OFF	ON	ON	ON	ON	OFF
123	ON	ON	OFF	ON	ON	ON	ON	OFF
124	OFF	OFF	ON	ON	ON	ON	ON	OFF
125	ON	OFF	ON	ON	ON	ON	ON	OFF

126	OFF	ON	ON	ON	ON	ON	ON	OFF
127	ON	ON	ON	ON	ON	ON	ON	OFF
128	OFF	OFF	OFF	OFF	OFF	OFF	OFF	ON
129	ON	OFF	OFF	OFF	OFF	OFF	OFF	ON
130	OFF	ON	OFF	OFF	OFF	OFF	OFF	ON
131	ON	ON	OFF	OFF	OFF	OFF	OFF	ON
132	OFF	OFF	ON	OFF	OFF	OFF	OFF	ON
133	ON	OFF	ON	OFF	OFF	OFF	OFF	ON
134	OFF	ON	ON	OFF	OFF	OFF	OFF	ON
135	ON	ON	ON	OFF	OFF	OFF	OFF	ON
136	OFF	OFF	OFF	ON	OFF	OFF	OFF	ON
137	ON	OFF	OFF	ON	OFF	OFF	OFF	ON
138	OFF	ON	OFF	ON	OFF	OFF	OFF	ON
139	ON	ON	OFF	ON	OFF	OFF	OFF	ON
140	OFF	OFF	ON	ON	OFF	OFF	OFF	ON
141	ON	OFF	ON	ON	OFF	OFF	OFF	ON
142	OFF	ON	ON	ON	OFF	OFF	OFF	ON
143	ON	ON	ON	ON	OFF	OFF	OFF	ON
144	OFF	OFF	OFF	OFF	ON	OFF	OFF	ON
145	ON	OFF	OFF	OFF	ON	OFF	OFF	ON
146	OFF	ON	OFF	OFF	ON	OFF	OFF	ON
147	ON	ON	OFF	OFF	ON	OFF	OFF	ON
148	OFF	OFF	ON	OFF	ON	OFF	OFF	ON
149	ON	OFF	ON	OFF	ON	OFF	OFF	ON
150	OFF	ON	ON	OFF	ON	OFF	OFF	ON
151	ON	ON	ON	OFF	ON	OFF	OFF	ON
152	OFF	OFF	OFF	ON	ON	OFF	OFF	ON
153	ON	OFF	OFF	ON	ON	OFF	OFF	ON
154	OFF	ON	OFF	ON	ON	OFF	OFF	ON
155	ON	ON	OFF	ON	ON	OFF	OFF	ON
156	OFF	OFF	ON	ON	ON	OFF	OFF	ON
157	ON	OFF	ON	ON	ON	OFF	OFF	ON
158	OFF	ON	ON	ON	ON	OFF	OFF	ON
159	ON	ON	ON	ON	ON	OFF	OFF	ON
160	OFF	OFF	OFF	OFF	OFF	ON	OFF	ON
161	ON	OFF	OFF	OFF	OFF	ON	OFF	ON
162	OFF	ON	OFF	OFF	OFF	ON	OFF	ON
163	ON	ON	OFF	OFF	OFF	ON	OFF	ON
164	OFF	OFF	ON	OFF	OFF	ON	OFF	ON
165	ON	OFF	ON	OFF	OFF	ON	OFF	ON
166	OFF	ON	ON	OFF	OFF	ON	OFF	ON
167	ON	ON	ON	OFF	OFF	ON	OFF	ON
168	OFF	OFF	OFF	ON	OFF	ON	OFF	ON
169	ON	OFF	OFF	ON	OFF	ON	OFF	ON
170	OFF	ON	OFF	ON	OFF	ON	OFF	ON
171	ON	ON	OFF	ON	OFF	ON	OFF	ON
172	OFF	OFF	ON	ON	OFF	ON	OFF	ON
173	ON	OFF	ON	ON	OFF	ON	OFF	ON
174	OFF	ON	ON	ON	OFF	ON	OFF	ON
175	ON	ON	ON	ON	OFF	ON	OFF	ON
176	OFF	OFF	OFF	OFF	ON	ON	OFF	ON
177	ON	OFF	OFF	OFF	ON	ON	OFF	ON
178	OFF	ON	OFF	OFF	ON	ON	OFF	ON
179	ON	ON	OFF	OFF	ON	ON	OFF	ON
180	OFF	OFF	ON	OFF	ON	ON	OFF	ON
181	ON	OFF	ON	OFF	ON	ON	OFF	ON
182	OFF	ON	ON	OFF	ON	ON	OFF	ON
183	ON	ON	ON	OFF	ON	ON	OFF	ON
184	OFF	OFF	OFF	ON	ON	ON	OFF	ON
185	ON	OFF	OFF	ON	ON	ON	OFF	ON
186	OFF	ON	OFF	ON	ON	ON	OFF	ON
187	ON	ON	OFF	ON	ON	ON	OFF	ON
188	OFF	OFF	ON	ON	ON	ON	OFF	ON
189	ON	OFF	ON	ON	ON	ON	OFF	ON

Installation

190	OFF	ON	ON	ON	ON	ON	OFF	ON
191	ON	ON	ON	ON	ON	ON	OFF	ON
192	OFF	OFF	OFF	OFF	OFF	OFF	ON	ON
193	ON	OFF	OFF	OFF	OFF	OFF	ON	ON
194	OFF	ON	OFF	OFF	OFF	OFF	ON	ON
195	ON	ON	OFF	OFF	OFF	OFF	ON	ON
196	OFF	OFF	ON	OFF	OFF	OFF	ON	ON
197	ON	OFF	ON	OFF	OFF	OFF	ON	ON
198	OFF	ON	ON	OFF	OFF	OFF	ON	ON
199	ON	ON	ON	OFF	OFF	OFF	ON	ON
200	OFF	OFF	OFF	ON	OFF	OFF	ON	ON
201	ON	OFF	OFF	ON	OFF	OFF	ON	ON
202	OFF	ON	OFF	ON	OFF	OFF	ON	ON
203	ON	ON	OFF	ON	OFF	OFF	ON	ON
204	OFF	OFF	ON	ON	OFF	OFF	ON	ON
205	ON	OFF	ON	ON	OFF	OFF	ON	ON
206	OFF	ON	ON	ON	OFF	OFF	ON	ON
207	ON	ON	ON	ON	OFF	OFF	ON	ON
208	OFF	OFF	OFF	OFF	ON	OFF	ON	ON
209	ON	OFF	OFF	OFF	ON	OFF	ON	ON
210	OFF	ON	OFF	OFF	ON	OFF	ON	ON
211	ON	ON	OFF	OFF	ON	OFF	ON	ON
212	OFF	OFF	ON	OFF	ON	OFF	ON	ON
213	ON	OFF	ON	OFF	ON	OFF	ON	ON
214	OFF	ON	ON	OFF	ON	OFF	ON	ON
215	ON	ON	ON	OFF	ON	OFF	ON	ON
216	OFF	OFF	OFF	ON	ON	OFF	ON	ON
217	ON	OFF	OFF	ON	ON	OFF	ON	ON
218	OFF	ON	OFF	ON	ON	OFF	ON	ON
219	ON	ON	OFF	ON	ON	OFF	ON	ON
220	OFF	OFF	ON	ON	ON	OFF	ON	ON
221	ON	OFF	ON	ON	ON	OFF	ON	ON
222	OFF	ON	ON	ON	ON	OFF	ON	ON
223	ON	ON	ON	ON	ON	OFF	ON	ON
224	OFF	OFF	OFF	OFF	OFF	ON	ON	ON
225	ON	OFF	OFF	OFF	OFF	ON	ON	ON
226	OFF	ON	OFF	OFF	OFF	ON	ON	ON
227	ON	ON	OFF	OFF	OFF	ON	ON	ON
228	OFF	OFF	ON	OFF	OFF	ON	ON	ON
229	ON	OFF	ON	OFF	OFF	ON	ON	ON
230	OFF	ON	ON	OFF	OFF	ON	ON	ON
231	ON	ON	ON	OFF	OFF	ON	ON	ON
232	OFF	OFF	OFF	ON	OFF	ON	ON	ON
233	ON	OFF	OFF	ON	OFF	ON	ON	ON
234	OFF	ON	OFF	ON	OFF	ON	ON	ON
235	ON	ON	OFF	ON	OFF	ON	ON	ON
236	OFF	OFF	ON	ON	OFF	ON	ON	ON
237	ON	OFF	ON	ON	OFF	ON	ON	ON
238	OFF	ON	ON	ON	OFF	ON	ON	ON
239	ON	ON	ON	ON	OFF	ON	ON	ON
240	OFF	OFF	OFF	OFF	ON	ON	ON	ON
241	ON	OFF	OFF	OFF	ON	ON	ON	ON
242	OFF	ON	OFF	OFF	ON	ON	ON	ON
243	ON	ON	OFF	OFF	ON	ON	ON	ON
244	OFF	OFF	ON	OFF	ON	ON	ON	ON
245	ON	OFF	ON	OFF	ON	ON	ON	ON
246	OFF	ON	ON	OFF	ON	ON	ON	ON
247	ON	ON	ON	OFF	ON	ON	ON	ON
248	OFF	OFF	OFF	ON	ON	ON	ON	ON
249	ON	OFF	OFF	ON	ON	ON	ON	ON
250	OFF	ON	OFF	ON	ON	ON	ON	ON
251	ON	ON	OFF	ON	ON	ON	ON	ON
252	OFF	OFF	ON	ON	ON	ON	ON	ON
253	ON	OFF	ON	ON	ON	ON	ON	ON

254	OFF	ON	ON	ON	ON	ON	ON	ON
255	ON	ON	ON	ON	ON	ON	ON	ON

Connections

Precautions

- The connections should be made by qualified service personnel or system installers in accordance with all local codes.
- DC 12V can be used.

Note:

When powered up, the unit performs a self-check (including one panning, tilting, zooming and focusing operation).

Connection preview

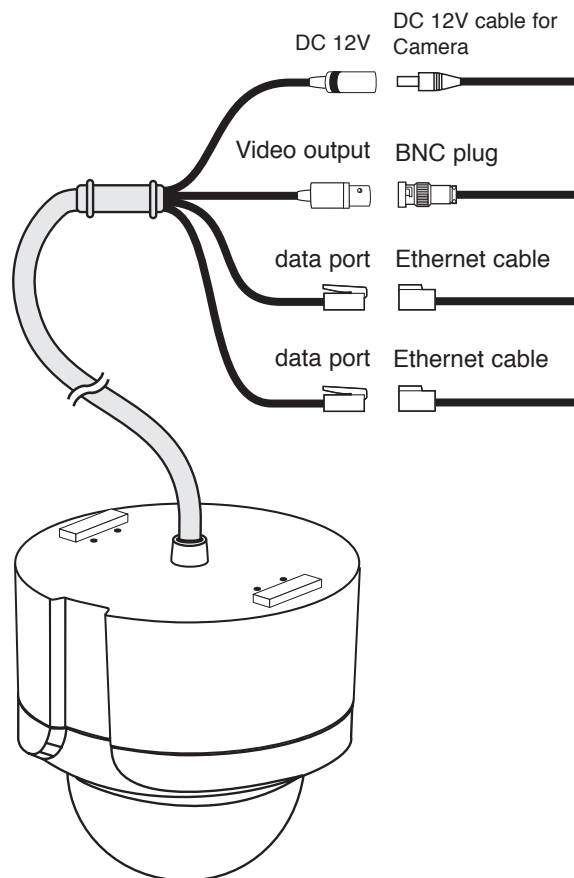

RS-485 connection

Use the cable that is described below for RS-485 site communication.

- Shielded, twisted pair cable
- Low impedance
- Wire gauge size is thicker than AWG #22 (0.33 mm²).

Connecting monitor

The video signal connection between the camera and the monitor.

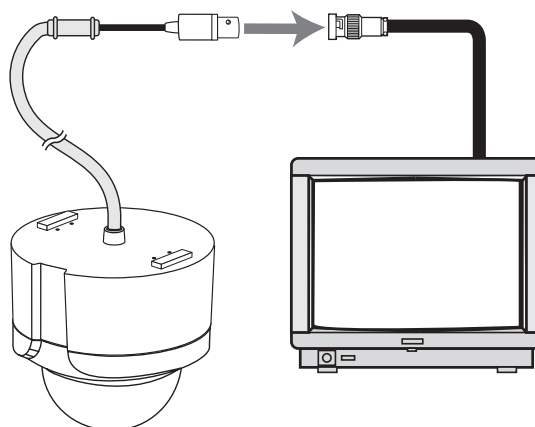

Connecting power source

Connect a DC 12 V power source to the power input terminal.

ALARM IN connections

Connect external sensors to the 8-pin hanness connector. Each alarm sensor should be connected with G (GND). Input specifications are low-active, non-voltage contact (ON when active) or open collector (Low when active).

Cautions

- Alarm input connection must be connected to only one port of two communication ports.
- Do not connect one alarm sensor to the several camera's alarm input connector.

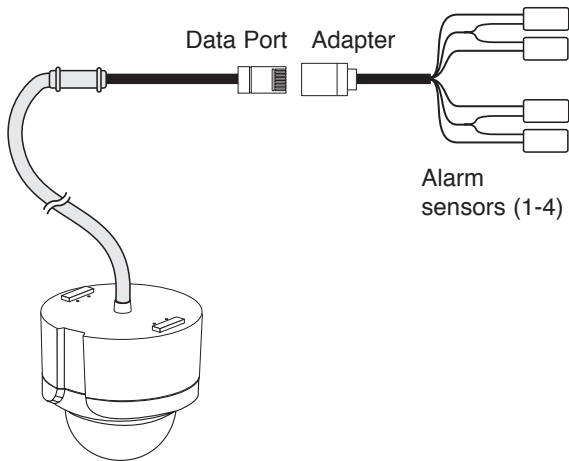

Alarm Input function

This speed dome camera has a terminal that can sense the alarm signals.

If the alarm sensor that has installed in a door, window, safe etc. sense a touch or shock, the alarm sensor send the alarm signal to the camera and the camera will observe the sensed position.

There are "Manual mode" and "Auto mode" for the Alarm Input function.

- Manual mode: Change the observe position to a sensor that senses a touch or shock then keep observe the sensed position. (Set the Duration Time of Alarm Input function to "0" using the LKD1000 controller.)

<Example: If this unit receives signal from "Alarm 4">

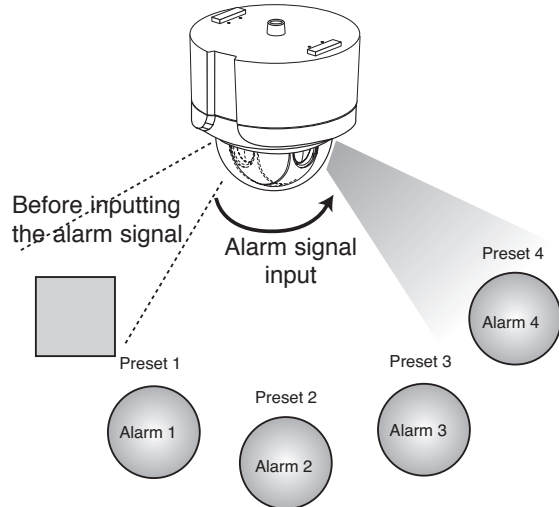

Connection of the data port and adapter for alarm input

No	Description	Color
1	ALARM IN 1	Black
2	ALARM IN 2	Brown
3	GND	Red
4	TRX D -	Orange
5	TRX D +	Yellow
6	GND	Green
7	ALARM IN 3	Blue
8	ALARM IN 4	White

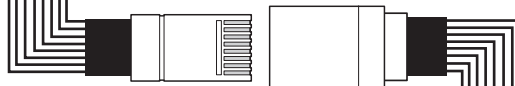

No	Description	Color
1	ALARM IN 1	Brown
2	ALARM IN 2	Blue
3	GND	Yellow
4	TRX D -	Green
5	TRX D +	Red
6	GND	Black
7	ALARM IN 3	Orange
8	ALARM IN 4	White

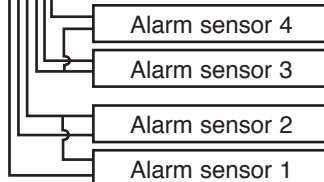

Function status	Manual mode
While observe a specific position.	Change the observe position to the alarmed position then keep observe the alarmed position and you cannot control the camera. If you want to control the camera, you should set the Duration Time of Alarm Input function to "1 to 255" using the LKD1000 controller.
While operating Preset Tour function.	Stop preset touring and change the observe position to the alarmed position then keep observe the alarmed position.

While operating Auto Pan function.	Stop auto panning and change the observe position to the alarmed position then keep observe the alarmed position.
While operating Pattern function.	Stop operating pattern function and change the observe position to the alarmed position then keep observe the alarmed position.

While operating Pattern function.	Stop operating pattern function and change the observe position to the alarmed position then restart the pattern function again.
-----------------------------------	--

Note:

The Alarm In 1 is Preset 1, Alarm In 2 is Preset 2, Alarm In 3 is Preset 3 and Alarm In 4 is Preset 4.

- Auto mode: Change the observe position to a sensor that senses a touch or shock then return to the position that previously observed. (Set the Duration Time of Alarm Input function to "1 to 255".)

<Example : If this unit receives signal from "Alarm 4">

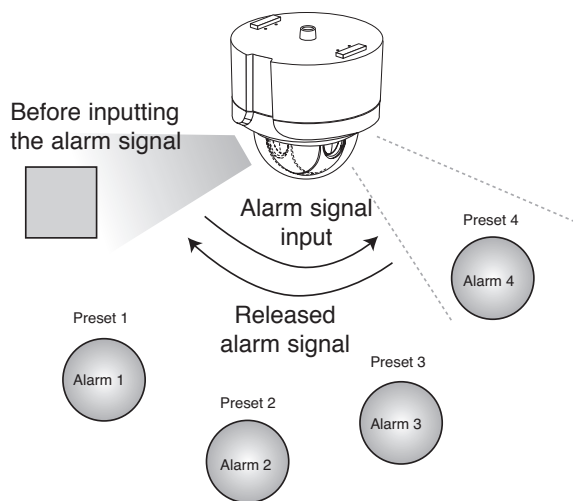

Connecting LKD1000 controller

Connecting the LKD1000 controller to control the camera. (Refer to the manuals of the LKD1000 controller for more details.)

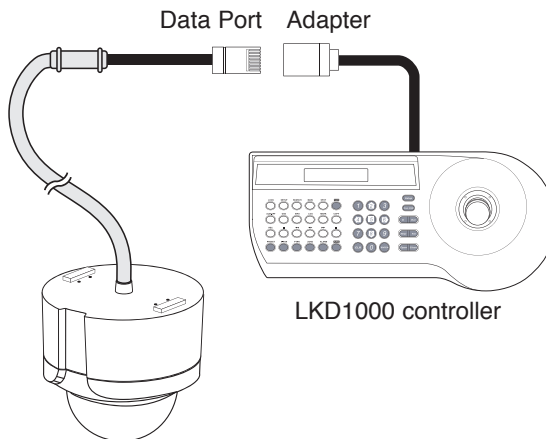

Function status	Auto mode
While observe a specific position.	Change the observe position to the alarmed position then return to the position that previously observed.
While operating Preset Tour function.	Stop preset touring and change the observe position to the alarmed position then restart the preset touring again.
While operating Auto Pan function.	Stop auto panning and change the observe position to the alarmed position then restart the auto panning again.

Connection of the data port and adapter with LKD1000 controller

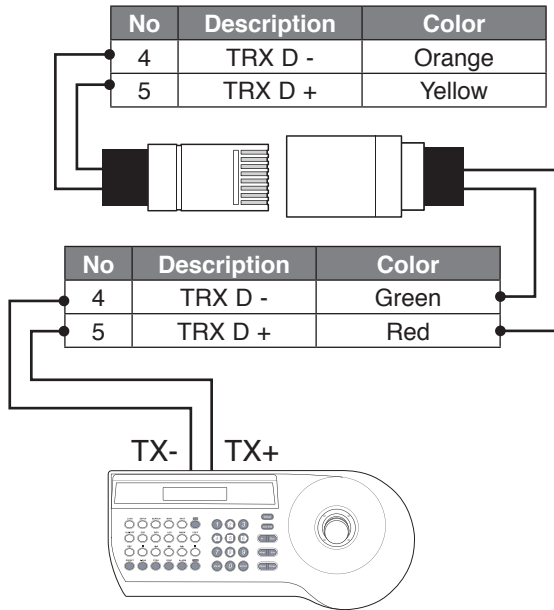

System Connection

Note:

When any peripheral is turned off and turned on again, the camera is also turned off and turned back on.

Caution:

Do not connect the alarm connectors to the another camera's alarm connectors.

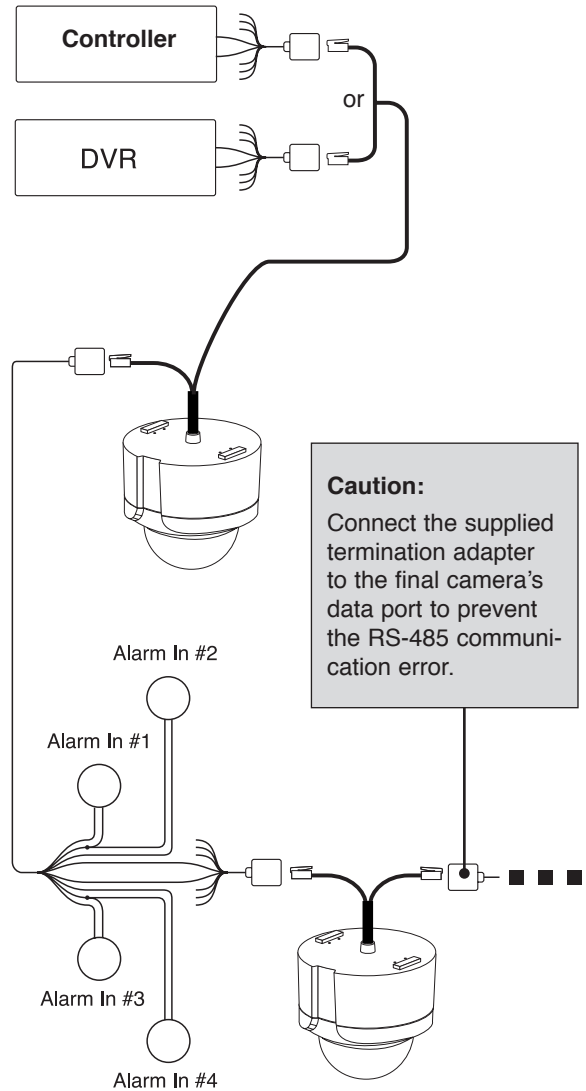

Operation

Setup Menu Overview

The following table shows the list of menu items and options. You can adapt the camera to your requirements by setting up the respective items in these menus.

Main Menu	Sub Menu	Contents		
FOCUS	FOCUS MODE	AUTO/ ONE PUSH/ ZOOM TRIG/ MANUAL		
	FOCUS DIST	50CM, 1M, 3M, 5M		
	ZOOM START	x1~x26		
	ZOOM END	x2~x324		
	ZOOM SPEED	SLOW/ MIDDLE/ QUICK		
	ZTRK MODE	AUTO/ MANUAL/ AUTO ONLY		
	INITIAL SET			
	EXIT	RET/TOP/END		
EXPOSURE	IRIS	AUTO/MANUAL		
	AGC	OFF/LOW/MIDDLE/HIGH		
	WDR/BLC	OFF/WDR/BLC/HSBLC		
	BRIGHTNESS	0~100		
	SHUTTER	X512, ~, x2, AUTO, OFF, A.FLK, 1/160, ~, 1/90000		
	SENS-UP	OFF, AUTO x2 ~ AUTO x128		
	INITIAL SET			
	EXIT	RET/TOP/END		
WHITE BALANCE	ATW			
	AUTO			
	ONE PUSH			
	MANUAL	COLOR TEMP	INDOOR, OUTDOOR	
		RED	-100 ~ 100	
		BLUE	-100 ~ 100	
		INITIAL SET		
	EXIT	RET/TOP/END		

Main Menu	Sub Menu	Contents			
DAY/NIGHT	AUTO	D/N LEVEL	LOW/ MIDDLE/ HIGH		
		DWELL TIME	5, 10, 15, 30, 60 sec		
		INITIAL SET			
		EXIT	RET/TOP/END		
	DAY				
NIGHT					
	OFF				
MOTION DET	ON	ZONE NUMBER	ZONE1 ~ ZONE4		
		ZONE STATE	OFF, ON		
		WIDTH			
		HEIGHT			
		MOVE X			
		MOVE Y			
		SENSITIVITY			
		INITIAL SET			
		EXIT	RET/TOP/END		
			OFF		
PRIVACY MASK	ON	MASK NUMBER	MASK1 ~ MASK8		
		MASK STATE	OFF, ON		
		MASK COLOR	BLACK, GRAY, WHITE		
		WIDTH			
		HEIGHT			
		MOVE X			
		MOVE Y			
		RESET MASK			
		INITIAL SET			
		EXIT	RET/TOP/END		
			OFF		
		3D-DNR	LOW		
			MIDDLE		
HIGH					
	OFF				

Main Menu	Sub Menu	Contents	
SPECIAL	CAMERA ID	0~255	
	D-EFFECT	Not supported.	
	COLOR	OFF	
		ON	COLOR LEVEL
	FREEZE	OFF/ ON	
	SHARPNESS	0~68	
	STABILIZER	OFF/ ON	
	OSD	OFF	
		ON	USER TITLE
			ZOOM MAG
			FUNCTION
			CAMERA ID
	LANGUAGE	ENG (The supported language can be different depending on the model.)	
INITIAL SET			
EXIT	RET/TOP/END		
RESET	FACTORY RESET		
	S/W VERSION		
	REBOOT		
	EXIT	RET/TOP/END	
EXIT			





Note:

The Preset, Auto Pan, Pattern, Alarm functions could not be set on the OSD menu. To set these functions, use LKD1000 controller.

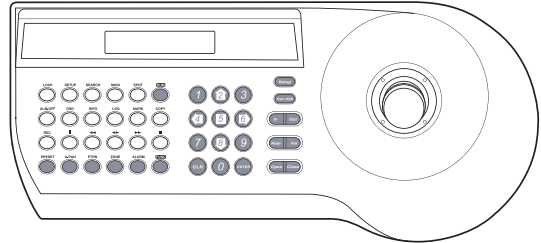
Menu navigation

We use the LKD1000 controller in this manual to explain the features of the LG Dome camera because of the LKD1000's ability to control all of the LG Dome camera's advanced features. (For detailed controller instructions, refer to the LKD1000 Controller Manual.)



Buttons	Function
	Cam OSD button Displays the setup menu or cancels operation of the setup menu.
	ZOOM IN button Use to move upper direction on the menu screen.
	ZOOM OUT button Use to move lower direction on the menu screen.
	FOCUS NEAR button Use for increase the value of the option.
	FOCUS FAR button Use for decrease the value of the option.
	Open/Close (Enter) buttons Executes selections and displays a submenu for an item with the  mark.

Accessing setup menus

To access the setup menus using the keys on a LKD1000 controller, do the following:

1. Select CAM (Camera) icon in the main menu and then press **ENTER**. The camera ID input menu will be displayed.

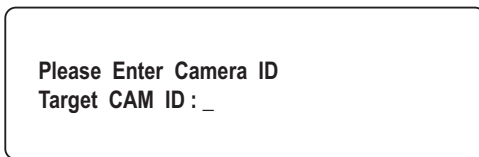

2. Enter the connected camera ID to control the camera connected to the LKD1000 controller directly and then press **ENTER**. The camera control menu will be displayed.

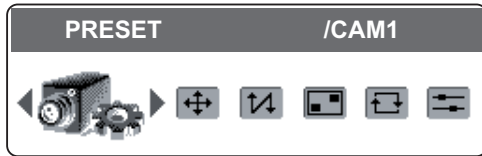

3. Press **[Cam OSD]** button to display the camera setup menu.

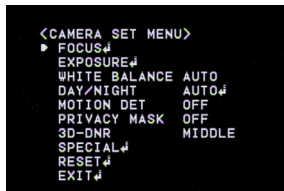

At this point, you have access to the camera setup menu.

General Operation

1. Use **[In]** or **[Out]** button to select an option then press **[Open]** or **[Close]** button. Submenu appears on the monitor.
2. Use **[In]** or **[Out]** button to select a submenu option.
3. Use **[Near]** or **[Far]** button to select a value.
4. Select **[EXIT]** option then press **[Open]** or **[Close]** to exit the setup menu. In the submenu, use **[In]** or **[Out]** button to select the **[EXIT]** then use **[Near]** or **[Far]** button to select a mode and press **[Open]** or **[Close]** to exit the setup menu.
 - RET: Return to the previous.
 - TOP: Return to the CAMERA SETTING menu screen.
 - END: Exit the setup menu.

Focus setting

Focus Mode setting

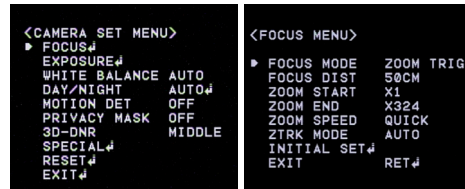

The camera adjusts the focus automatically by sensing the center of the picture.

Select **[FOCUS MODE]** option on the **[FOCUS]** menu, then select the following mode.

- **AUTO:** Auto-focus is activated automatically.
- **ONE PUSH:** The focus is activated manually. If the camera is received auto-focus command, the camera is activated Auto-focus mode and the focus is set automatically and then the focus mode is automatically changed to manual mode.
- **ZOOM TRIG:** The focus is activated manually. If you change the zoom, the focus is activated Automatically and then the focus mode is automatically changed to manual mode.
- **MANUAL:** Focus is activated only when the **FOCUS (NEAR or FAR)** keys on the controller is pressed.

Focus Distance setting

```
<FOCUS MENU>
FOCUS MODE   ZOOM TRIG
▶ FOCUS DIST 50CM
ZOOM START   X1
ZOOM END     X324
ZOOM SPEED   QUICK
ZTRK MODE    AUTO
INITIAL SET  RET↵
EXIT
```

Selects the minimum shooting distance for the focus. Select [FOCUS DIST] option on the [FOCUS] menu, then select a focus distance value (50CM, 1M, 3M, 5M).

Zoom Speed setting

```
<FOCUS MENU>
FOCUS MODE   ZOOM TRIG
FOCUS DIST   50CM
ZOOM START   X1
ZOOM END     X324
▶ ZOOM SPEED QUICK
ZTRK MODE    AUTO
INITIAL SET  RET↵
EXIT
```

Selects a zoom speed. Select [ZOOM SPEED] option on the [FOCUS] menu, then select a zoom speed (SLOW, MIDDLE or QUICK).

Zoom Start setting

```
<FOCUS MENU>
FOCUS MODE   ZOOM TRIG
FOCUS DIST   50CM
▶ ZOOM START  X1
ZOOM END     X324
ZOOM SPEED   QUICK
ZTRK MODE    AUTO
INITIAL SET  RET↵
EXIT
```

You can set the zoom start position of the camera. When the zoom function is operated, the zoom always will start at the selected zoom start position. Select [ZOOM START] option on the [FOCUS] menu, then set a zoom start position (x1 - x26).

Zoom Tracking Mode setting

```
<FOCUS MENU>
FOCUS MODE   ZOOM TRIG
FOCUS DIST   50CM
ZOOM START   X1
ZOOM END     X324
ZOOM SPEED   QUICK
▶ ZTRK MODE  AUTO
INITIAL SET  RET↵
EXIT
```

Selects a zoom tracking mode. Zoom tracking means focused zooming state. Select [ZTRK MODE] option on the [FOCUS] menu, then select a zoom tracking mode (AUTO or MANUAL).

Zoom End setting

```
<FOCUS MENU>
FOCUS MODE   ZOOM TRIG
FOCUS DIST   50CM
ZOOM START   X1
▶ ZOOM END   X324
ZOOM SPEED   QUICK
ZTRK MODE    AUTO
INITIAL SET  RET↵
EXIT
```

You can set the zoom end position of the camera. If you set the zoom end position, the zoom is operated up to the selected zoom end position. Select [ZOOM END] option on the [FOCUS] menu, then set the zoom end position ("Zoom Start position+1" ~ x324).

If the FOCUS MODE is set to [AUTO], the ZTRK MODE is set to [AUTO] and you can not change the ZTRK MODE.

Exposure settings

Iris setting

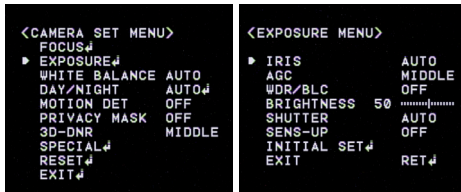

Select the desired lens iris value for camera exposure. Select [IRIS] option on the [EXPOSURE] menu, then select a value. (AUTO or MANUAL).

- AUTO: The lens iris is set automatically.
- MANUAL: Use [Near] or [Far] button to select the DC Iris level.

AGC (Automatic Gain Control) setting

If the images are too dark, change the maximum [AGC] value to make the images lighter.

1. Select [AGC] option on the [EXPOSURE] menu.



2. Use [Near] or [Far] button to select a mode. (OFF ↔ LOW ↔ MIDDLE ↔ HIGH)

WDR/BLC setting

Use WDR/BLC option to set the options for BLC or WDR camera.

1. Select [WDR/BLC] option on the [EXPOSURE] menu.



2. Use [Near] or [Far] button to select a mode then press [Open] or [Close].
 - WDR: Set the WDR limit.

- WDR LEVEL: LOW ↔ MIDDLE ↔ HIGH
- BLC: Set the BLC limit.
 - BLC LEVEL: LOW ↔ MIDDLE ↔ HIGH
- HSBL: Use for adjusting brightness the specific area of picture. The HSBL mode is automatically activated only in low illuminance scene.
 - AREA SETTING: Use [Near] or [Far] button to select a area then use [In] or [Out] button to select a area then use [In] or [Out] button to select a ON or OFF. Press [Open] or [Close] to exit the area setting menu.
 - GRAY SCALE: Use [Near] or [Far] button to select a gray scale. (GRAY ↔ D.GRAY ↔ BLACK).
 - HS LEVEL: Use [Near] or [Far] button to select a bright level. (5 level)
 - MASK STATE: Use [Near] or [Far] button to select [ON] or [OFF].
If you set the MASK STATE to ON, the mask function is activate only when the HSBL is activated by auto mode.
 - OFF: Not used.

BRIGHTNESS setting

You can increase the brightness of the darkened video. If you set the brightness to lower value, the image is darkened. If you set the brightness to higher value, the image gets bright.

1. Select [BRIGHTNESS] option on the [EXPOSURE] menu.

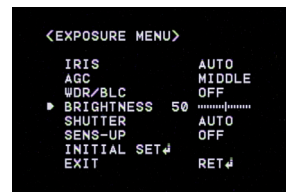

2. Use [Near] or [Far] button to set the bright level.

SHUTTER (Shutter Speed) setting

Select the desired shutter speed for camera exposure. You can change the shutter speed to higher speed to capture fast-moving subjects, though the image becomes darker.

1. Select [SHUTTER] option on the [EXPOSURE] menu.



2. Use [Near] or [Far] button to set shutter speed. (x512~x2 ↔ AUTO ↔ OFF ↔ A.FLK ↔ 1/160 ~ 1/90000)

SENS-UP setting

If pictures are not clear due to darkness, use for increase the sensitivity of picture.

1. Select [SENS-UP] option on the [EXPOSURE] menu.



2. Use [Near] or [Far] button to set the SENS-UP limit (OFF, AUTO x2 ~ AUTO x128). To setting the SENS-UP function, select the [AUTO] on the [SHUTTER].

Note:

If you set to one of the SHUTTER options except AUTO on the [SHUTTER] menu, the [SENS-UP] setting is not available and [---] mark is displayed.

White Balance setting

Select the method by which the camera shifts its output colors to compensate for the color of a light source.

1. Select [WHITE BALANCE] option on the [CAMERA SET] menu.



2. Use [Near] or [Far] button to select a mode then press [Open] or [Close].
 - ATW (Auto-Tracing White Balance): In this mode, the color temperature range for the proper white balance is approximately 1,800 - 10,500°K. Proper white balance may not be obtained under the following conditions:
 - When the color temperature is out of the 1,800 - 10,500°K range.
 - When the scene contains mostly high color temperature objects, such as a blue sky or sunset.
 - When the scene is dim.
 - AUTO: In this mode, the color temperature range for the proper white balance is approximately 2,700 - 5,400°K. Proper white balance may not be obtained under the following conditions:
 - When the color temperature is out of the 2,700 - 5,400°K range.
 - When the scene contains mostly high color temperature objects, such as a blue sky or sunset.
 - When the scene is dim.
 - ONE PUSH: If you select the ONE PUSH mode, you will be able to set up the White Balance automatically using [Open] or [Close] button.
 - MANUAL: You can set the white balance options manually.



- COLOR TEMP: Use **[Near]** or **[Far]** button to select a function.
 - > INDOOR: The color temperature range for the proper white balance is approximately 3,200°K.
 - > OUTDOOR: The color temperature range for the proper white balance is approximately 5,100°K.
- RED: Set the desired red value. (-100~100)
- BLUE: Set the desired blue value. (-100~100)

Day/Night setting

1. Select **[DAY/NIGHT]** option on the **[CAMERA SET]** menu.



2. Use **[Near]** or **[Far]** button to select mode for day/night function.
 - AUTO: You will be able to change the Day/Night mode automatically.

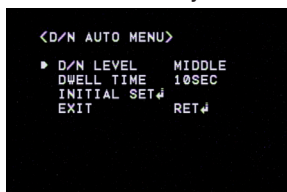

- D/N LEVEL: Use **[Near]** or **[Far]** button to select a level. (LOW↔MIDDLE↔HIGH)
- DWELL TIME: Use **[Near]** or **[Far]** button to select a dwell time. (5, 10, 15, 30 or 60 sec.)

Note:

If you set the AGC to **[OFF]** or the SHUTTER is set to one of the SHUTTER options except **AUTO** on the **[EXPOSURE]** menu, the **AUTO** mode of the **DAY/NIGHT** function is not available and **[---**] mark is displayed.

- DAY: Color mode enabled.
- NIGHT: Black-and-white mode enabled.

Motion Detection setting

The motion detection detects the moving objects in the scene by monitoring changes in brightness level. You can select the level of sensitivity for motion detection to 4 zone.

1. Select **[MOTION DET]** option on the **[CAMERA SET]** menu.
2. Use **[Near]** or **[Far]** button to select a **[ON]** and press **[Open]** or **[Close]**. The **MOTION DETECTION** menu appears.

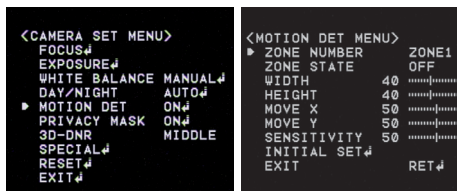

3. Use **[Near]** or **[Far]** button to select a zone number (ZONE1 ~ ZONE4) on the **[ZONE NUMBER]** option.
4. Use **[Near]** or **[Far]** button to set up the **ON** or **OFF** on the **[ZONE STATE]** option. If you set to **ON**, the zone frame appears on the center of the monitor.
5. Use **[In]** or **[Out]** to select an option then use **[Near]** or **[Far]** button to adjust the option
 - WIDTH: Enlarge or decrease the horizontal size of the zone frame.
 - HEIGHT: Enlarge or decrease the vertical size of the zone frame.
 - MOVE X: Moves horizontal position of the zone frame.
 - MOVE Y: Moves vertical position of the zone frame.
6. Use **[SENSITIVITY]** option to obtain the optimum detection level.

Privacy Mask setting

This function is aiming at the protection of personal privacy, selecting a screen part black not to be displayed in the screen. Up to 8 zones can be registered.

1. Select [PRIVACY MASK] option on the [CAMERA SET] menu.
2. Use [Near] or [Far] button to select a [ON] and press [Open] or [Close]. The PRIVACY MASK menu appears.

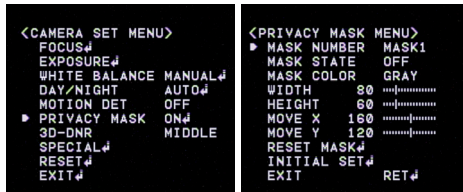

3. Use [Near] or [Far] button to select a zone number (MASK1 ~ MASK8) on the [MASK NUMBER] option.
4. Use [Near] or [Far] button to set up the ON or OFF on the [MASK STATE] option. If you already registered the mask zone and set to ON, the mask zone box appears on the monitor.
5. Use [Near] or [Far] button to select the color of the mask zone box on the [MASK COLOR] option.
6. Select [RESET MASK] and press [Open] or [Close]. If you register the mask zone for the first time, the mask zone box appears on the center of the monitor. If you already registered mask zone, it will be returned to its initial state and appear on the center of the monitor.
7. Use [In] or [Out] to select an option then use [Near] or [Far] button to adjust the option.
 - WIDTH: Enlarge or decrease the horizontal size of the mask zone box.
 - HEIGHT: Enlarge or decrease the vertical size of the mask zone box.
 - MOVE X: Moves horizontal position of the mask zone box.
 - MOVE Y: Moves vertical position of the mask zone box.

Notes:

- If you want to reset the mask zone position, select RESET MASK option and press [Open] or [Close] button.
- The parts with the registered mask numbers from MASK1 to MASK4 have the same color. (So do the parts with the numbers from MASK5 to MASK8). If you change the mask color, the reg-

istered mask color will be changed automatically with the same color for each of group (MASK1~4, MASK5~8).

3D-DNR setting

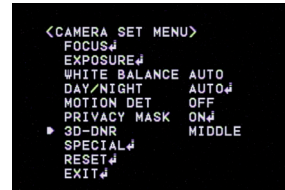

1. Select [3D-DNR] option.
If pictures are not clear due to brightness, use for reduce the noise of picture.
2. Use [Near] or [Far] button to select a option. (OFF↔LOW↔MIDDLE↔HIGH)

Notes:

- If you set the AGC to [OFF] on the [EXPOSURE] menu, the [3D-DNR] function is not available.
- When you use this function, the afterimage may occur.

Special menu settings

Camera Identification setting

Only displays the camera's ID. Use the internal 8 bit-DIP switch if you want to set ID.

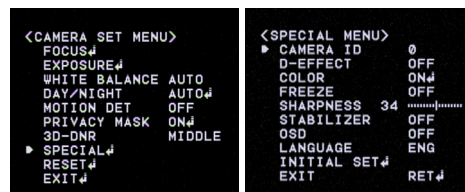

D-EFFECT (Digital effect) setting

This model does not support the D-EFFECT function.

Color setting

You can switch the displayed picture to grayscale or color.

1. Select [COLOR] option on the [SPECIAL] menu.



2. Use [Near] or [Far] button to change a color effect.
 - ON: To display the picture with color.
Select ON and Press [Open] or [Close] to display the submenu.
You can adjust the color level using the [Near] or [Far] button.
 - OFF: To display the picture with grayscale.

Freeze setting

1. Select [FREEZE] option on the [SPECIAL] menu.



2. Use [Near] or [Far] button to set up the ON or OFF.

Sharpness setting

Sharpens the image outline.

1. Select [SHARPNESS] option on the [SPECIAL] menu.

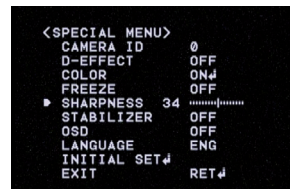

2. Use [Near] or [Far] button to change or adjust the option. If you set the sharpness value to higher, the image outline becomes sharp. If you set to lower value, the image outline becomes dim.

Stabilizer setting



The image stabilizer function minimizes the appearance of shaky images caused by low-frequency vibration.

This function is useful for outdoor surveillance.

Select [STABILIZER] option and set to ON or OFF.

Note:

If you set the [STABILIZER] to ON, the Digital zoom is set to [x1.1] automatically.

OSD setting

You can set the Function On-Screen Display options using the [OSD] menu.

The Function On-Screen Display of this camera can be turned on or off.

1. Select [OSD] option on the [SPECIAL] menu.
2. Use [Near] or [Far] button to select a [ON] and press [Open] or [Close]. The OSD menu appears.

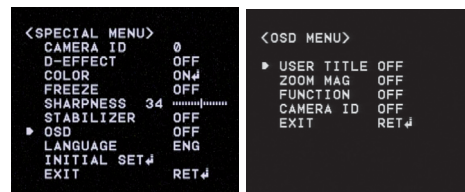

3. Use [In] or [Out] to select an option then use [Near] or [Far] button to set the option.
 - ON: Displays the Function OSD on the screen.
 - OFF: The Function OSD does not appear on the screen.

User title setting

You can use the camera identification to assign a number and character to the camera (0 - 9, A-Z, a-z). The USER TITLE is displayed on the upper left of the screen.

To disappear the user title, select [OFF].

1. Select [USER TITLE] option on the [SPECIAL] screen.
2. Use [**Near**] or [**Far**] button to select a [ON] then press [**Open**] or [**Close**]. The USER TITLE menu appears.

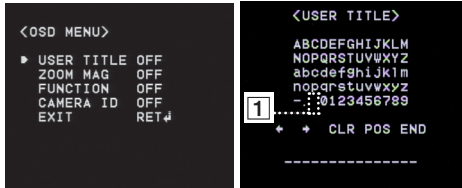

3. Use [**In**], [**Out**], [**Near**] or [**Far**] button to select a character or number.
 - CLR: If you enter the wrong code, select CLR then press [**Open**] or [**Close**].
 - POS: Use [**Near**] or [**Far**] button to move position of USER TITLE on the screen.
 - END: Confirm your selection.
 - **1** (Blank): Insert a space at the cursor position.
 - **←** / **→**: Moves cursor to left or right.

Language setting

Select a language for setup menu and information display.



Reset settings

1. Select [RESET] option.
2. Press [**Open**] or [**Close**] button and the RESET menu appears.

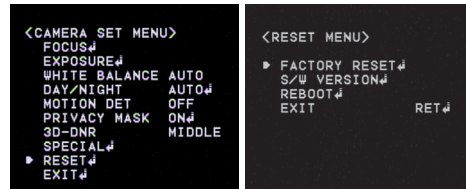

3. Use [**In**] or [**Out**] to select option.
 - FACTORY RESET: Clear certain settings and information and return to factory default settings.
 - S/W VERSION: Displays the software version on the monitor.
 - REBOOT: Reboot the camera system.
4. Press [**Open**] or [**Close**] to confirm your selection.

Reference

Specifications

Signal System	NTSC (High Resolution)	PAL (High Resolution)
Pick-Up Device	1/4" EX-view HAD CCD	
Total Pixels No	410K	470K
Sync System	Internal	
Lens	x27 Zoom (F1.5 (Wide End) , F3.6 (Tele End), f = 3.25mm ~ 88 mm	
Horizontal Resolution	More Than 520 TV Lines	
S/N Ratio	More Than 50dB (AGC Off)	
Minimum Illumination	Color Mode :0.003 (0.6) Lux (Sens-up OFF)	
	B/W Mode : 0.0001 (0.1) Lux (Sens-up OFF)	
Digital Zoom	X 12	
WDR (BLC)	OFF / WDR / BLC / HSBLC	
White Balance	Auto / ATW/ ONE PUSH / Manual(1800 °K ~ 10,500 °K)	
Video Output	Composite Output 1Vp-p (75 ΩTerminated)	
Electronic Shutter	1/60 ~1/90,000 sec	1/50 ~1/90,000 sec
Electronic Sensitivity	OFF / Auto (x2, x3, x4, ... , x 128)	
Flickerless Mode	Available	
Iris Control	Auto / Manual	
Control method	RS-485 Control	
Alarm Input	4 Channel	
Panning Range (Speed)	0° ~ 350°, Max. 120°/Sec	
Tilting Range (Speed)	0° ~ 180°, Max. 120°/Sec	
Privacy Zone	8 Area Active Programmable Zone	
Preset/ID	128 Position / 256	
Auto Panning	2 – 8 points	
Pattern	Max. 5 minutes	
Group Tour	Max. 9 Groups	
Operation Temperature	-10~50 °C (Humidity: 0%RH~80%RH)	
Safekeeping Temperature	-30~60 °C (Humidity: 0%RH~85%RH)	
Power Supply	DC 12V	
Power Consumption	Max. 12W	
Dimension(ø x H)	ø 174 x 167.3 mm	
Weight	Approx 2.9Kg	

