



MEDIA STATION

Network Twin HD Recorder

MS409D / MS408D

HDD
DETACHABLE

DVB
Digital Video
Broadcasting

WiFi
CERTIFIED®

dlna
CERTIFIED™

dts
2.0+Digital Out

HD
TV

You Tube™

Picasa™
Web Albums

Plays
Windows
Media™

MKV
PLAYBACK

DMX
HD

DOLBY
DIGITAL

FULLHD
1080P

HDMI™
HIGH DEFINITION MULTIMEDIA INTERFACE

N98

To ensure proper use of this product, please read this owner's manual carefully and retain for future reference.

English



CAUTION: TO REDUCE THE RISK OF ELECTRIC SHOCK DO NOT REMOVE COVER (OR BACK) NO USER-SERVICEABLE PARTS INSIDE REFER SERVICING TO QUALIFIED SERVICE PERSONNEL.



This lightning flash with arrowhead symbol within an equilateral triangle is intended to alert the user to the presence of uninsulated dangerous voltage within the product's enclosure that may be of sufficient magnitude to constitute a risk of electric shock to persons.



The exclamation point within an equilateral triangle is intended to alert the user to the presence of important operating and maintenance (servicing) instructions in the literature accompanying the product.

WARNING: TO PREVENT FIRE OR ELECTRIC SHOCK HAZARD, DO NOT EXPOSE THIS PRODUCT TO RAIN OR MOISTURE.

WARNING: Do not install this equipment in a confined space such as a book case or similar unit.

CAUTION: The apparatus should not be exposed to water (dripping or splashing) and no objects filled with liquids, such as vases, should be placed on the apparatus.

CAUTION concerning the Power Cord
Most appliances recommend they be placed upon a dedicated circuit;

That is, a single outlet circuit which powers only that appliance and has no additional outlets or branch circuits. Check the specification page of this owner's manual to be certain.

Do not overload wall outlets. Overloaded wall outlets, loose or damaged wall outlets, extension cords, frayed power cords, or damaged or cracked wire insulation are dangerous. Any of these conditions could result in electric shock or fire. Periodically examine the cord of your appliance, and if its appearance indicates damage or deterioration, unplug it, discontinue use of the appliance, and have the cord replaced with an exact replacement part by an authorized servicer.

Protect the power cord from physical or mechanical abuse, such as being twisted, kinked, pinched, closed in a door, or walked upon. Pay particular attention to plugs, wall outlets, and the point where the cord exits the appliance.

To disconnect power from the unit, unplug the unit from the outlet. When installing the product, ensure that the plug is easily accessible.

- The appliance is not intended for use by young children or infirm persons without supervision.
- Young Children should be supervised to ensure that they do not play with appliance.
- If the appliance is supplied from a cord extension set or an electrical portable outlet device, the cord extension set on electrical portable outlet device must be positioned so that it is not subject to splashing or ingress of moisture.

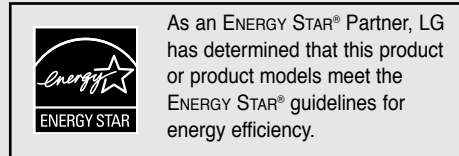

ENERGY STAR® is a U.S. registered mark.

Copyrights

- Recording equipment should be used only for lawful copying and you are advised to check carefully what is lawful copying in the area in which you are making a copy. Copying of copyright material such as films or music is unlawful unless permitted by a legal exception or consented to by the rights owner.
- This product incorporates copyright protection technology that is protected by method claims of certain U.S. patents and other intellectual property rights owned by Macrovision Corporation and other rights owners. Use of this copyright protection technology must be authorized by Macrovision Corporation, and is intended for home and other limited viewing uses only, unless otherwise authorized by Macrovision corporation. Reverse engineering or disassembly is prohibited.
- CONSUMERS SHOULD NOTE THAT NOT ALL HIGH DEFINITION TELEVISION SETS ARE FULLY COMPATIBLE WITH THIS PRODUCT AND MAY CAUSE ARTIFACTS TO BE DISPLAYED IN THE PICTURE. IN CASE OF 625 PROGRESSIVE SCAN PICTURE PROBLEMS, IT IS RECOMMENDED THAT THE USER SWITCH THE CONNECTION TO THE 'STANDARD DEFINITION' OUTPUT. IF THERE ARE QUESTIONS REGARDING OUR TV SET COMPATIBILITY WITH THIS MODEL 625p UNIT PLEASE CONTACT OUR CUSTOMER SERVICE CENTRE.

Licenses

Manufactured under license from Dolby Laboratories. Dolby and the double-D symbol are trademarks of Dolby Laboratories.

Manufactured under license under U.S. Patent #'s: 5,451,942; 5,956,674; 5,974,380; 5,978,762; 6,487,535 & other U.S. and worldwide patents issued & pending. DTS and DTS 2.0+ Digital Out are registered trademarks and the DTS logos and Symbol are trademarks of DTS, Inc. © 1996-2008 DTS, Inc. All Rights Reserved.

HDMI, the HDMI logo and High-Definition Multimedia Interface are trademarks or registered trademarks of HDMI licensing LLC.

YouTube is a trademark of Google Inc.

Picasa web albums is a trademark of Google Inc.

DLNA and DLNA CERTIFIED are trademarks and/or service marks of Digital Living Network Alliance.

WIFI CERTIFIED 802.11n based on Draft 2.0. Draft 2.0 refers to the version of the not-yet-ratified IEEE 802.11n standard used in Wi-Fi Alliance as of June 2007.

The "HD TV" Logo is trademark of DIGITALEUROPE. Trademark of DVB Digital video Broadcasting Project (1991 to 1996)

WARNING:

- Media contents including but not limited to broadcast materials, movie, music, and photo files are protected by copyright and that recording copy and playback of those contents would only be permissible by permission of the copyright owner. LG has no right to grant such permission. Permission should always be sought from the copyright owner.
- Andio and Video recordings and copies you make using this products are for your personal and non-commercial use only. You may sell, lend or rent them to other people. LG is not responsible for your panelties, disadvantages by illegal use of this product.

About the Symbol Display

"  " may appear on your TV display during operation and indicates that the function is not permitted by this recorder or specific media.

Symbol Used in this Manual



Indicates special notes and operating features.



Indicates tips and hints for making the task easier.



Indicates hazards likely to cause harm to the recorder itself or other material damage.

Table of contents

File requirement5	Resume playback	33
File compatibility5	Enlarges the playback image	33
Home Menu Overview6-7	Selecting a subtitle language	33
Remote control8	Selecting a subtitle code	33
Main unit9	Selecting an audio language	34
Connection overview10	Repeat playback	34
Connections to Your TV10	Playback from selected time	34
(Option A) Best quality - HDMI connection (includes audio and video)11	Add files to the Playlist	34
(Option B) Excellent quality - Component video and stereo audio connection12	Delete a file/folder from the list	35
(Option C) Connections to your TV (Composite)12	Naming a file	35
Connecting to an Amplifier13	Playing selected files	35
Connecting to an Amplifier via 2 Channel Audio Output13	Selecting a slideshow speed	35
Connecting to an Amplifier via Digital Audio Output (Optical or Coaxial)13	Selecting a slideshow effect	35
Connecting to an Amplifier via HDMI Output13	Listening to music while viewing a slideshow	35
Network connection14-19	Playing files on your PC36
Wired network connection14-15	Accessing your PC	36
Wireless network connection16-19	Editing the [My_Shortcuts]	36
Setup Wizard (Initial install)20	Using [File Copy] features37
		Copying or moving files/folders	37
		Deleting files/folders	37
DTV21-30	DLNA38-40
DTV Installation21	About DLNA38
Settings for Digital TV22-24	Notes on DLNA features	38
Selecting a Region22	Installing Nero MediaHome 4 Essentials	39
Scanning programmes automatically22	Sharing files and folders	39
Scanning programmes manually22	Operating DLNA feature40
Editing Programme List23	General operation	40
Setting the Lock System23	YouTube41-42
Setting a new password23	Operating YouTube feature41
Adjusting TV Rating level24	General operation	41
Setting the antenna power24	Searching YouTube videos	42
Setting the permanent Timeshift24	Selecting your local site	42
Setting recording storage24	Picasa43-44
Using the Digital TV functions25-27	Operating Picasa web albums feature43
Viewing the Digital TV25	General operation	43
Adjusting volume of audio out25	Searching Picasa web albums	44
Changing Digital TV programmes25	Viewing your Picasa web albums	44
Setting favorite programmes25	Removing an ID from the ID List	44
Viewing the programme information25	Setup45-48
Selecting DTV audio language25	General Setup Operation45
Selecting DTV subtitle language26	DTV settings	45
Viewing the EPG26	Audio settings	46
(Electronic Programme Guide) Display26	Display settings	46-47
Using the timeshift function manually26	Record settings	47
Using the permanent timeshift27	Network settings	47
Using the teletext (Viewing Teletext)27	System settings	48
Recording TV programmes28-30	Others settings	48
Normal Recording28	Reference49-57
Dual Programme Recording28	Software update via the Internet	49
Timer Recording (Manual)28	Software update via built-in tuner	49
Timer Recording (EPG)29	Formatting HDD	49
Canceling a timer recording29	External HDD Installation	50
Checking the history29	About the internal/External HDD	51
Editing a timer recording30	Connecting a USB device	51
Instant Timer Recording30	Controlling a TV with the Supplied Universal Remote Control	52
Media31-37	Code numbers of controllable TVs	53-54
Playback functions32-45	Troubleshooting	55-56
General playback	32	Specifications	57
Sorting the recorded titles	32	IMPORTANT INFORMATION RELATING TO NETWORK SERVICES58
Frame-by-Frame playback	33	Open source software notice59
Fast forward and fast reverse	33		
Slow down the playing speed	33		
Skip to the next/previous	33		

File requirement

File compatibility



- Because the compatibility and available playback functions on the [DLNA] menu are tested on the bundle DLNA server (Nero MediaHome 4 Essentials) environment, file requirements and playback functions on the [DLNA] menu may differ depending on the media servers.
- The file requirements on this page are not always compatible for DLNA features. There may have some restrictions by file features and media server's ability.
- This unit can recognize file/folder name less than 512 characters include path name.
- This unit can recognize files less than 4000 file/folders is one folder.
- Depending on the size and number of the files, it may takes several minutes to read the contents of the media.

Movie file

- Available resolution size: 1920 x1080 (W x H) pixels.
- The file names of movie and subtitle are limited to 50 characters.
- Supported extensions: ".avi", ".divx", ".mpg", ".mpeg", ".m2ts", ".mp4", ".mkv", ".wmv", ".ts", ".xvid", ".asf", ".mov", ".trp", ".dat", ".flv", ".mts", ".tp"
- Supported encodings: DIVX3.xx, DIVX4.xx, DIVX5.xx, XVID, "DIVX6.xx (Standard playback only), MPEG1/2, H.264/MPEG-4 AVC, WMV9, VC-1
- This device might not playback the file which is not encoded on the list, even though its extension belongs to "Supported extensions" above.
- Playable movie subtitle: SubRip (.srt / .txt), SAMI (.smi), SubStation Alpha (.ssa/.txt), MicroDVD (.sub/.txt), SubViewer 2.0 (.sub/.txt), VobSub (".idx" and ".sub" files should be together in the media)
- Playable Audio format: "Dolby Digital", "DTS", "MP3", "WMA", "AAC"
- Not all WMA Audio formats are compatible with this recorder.
- Sampling frequency: within 8 - 48 kHz (MP3), within 32 - 48 kHz (WMA)
- Bit rate: within 8 - 320 kbps (MP3), within 32 - 192 kbps (WMA)
- This recorder supports H.264/MPEG-4 AVC profile Main, High at Level 4.1. and Baseline at Level 3.1
- For a file with higher level, the recorder will ask whether you want to play or not.
- Displaying subtitle on DLNA is only available for bundle DLNA server (Nero MediaHome 4 Essentials) environment.

- This recorder does not support the file that are recorded with GMC. (GMC: Global Motion Compensation)

Music files

- File extensions: ".mp3", ".wma", ".aac", ".ogg", ".asf", ".flac", ".mp4"
- Sampling frequency: within 8 - 48 kHz (MP3), within 32 - 48kHz (WMA)
- Bit rate: within 8 - 320kbps (MP3), within 32 - 192kbps (WMA)
- This recorder does not support the ID3 Tag embedded in the MP3 file.
- The total playback time indicated on the screen may not correct for VBR files.
- The total playback time will not be displayed for ".aac", and ".flac" files.

Photo file

- **File extensions:** ".jpg", ".jpeg", ".bmp", ".png", ".gif", ".tif/tiff"
- Photo files with ".png", ".gif" or ".tif" extensions are not be completely supported on this recorder. Only limited basic format of them are supported.
- **Recommended size:**
Less than 4,000 x 3,000 x 24 bit/pixel
Less than 3,000 x 3,000 x 32 bit/pixel
- Progressive and lossless compression photo image files are not supported.

Home Menu Overview

Starting from HOME

To access numerous functions of the server, press the "HOME" button on the remote.

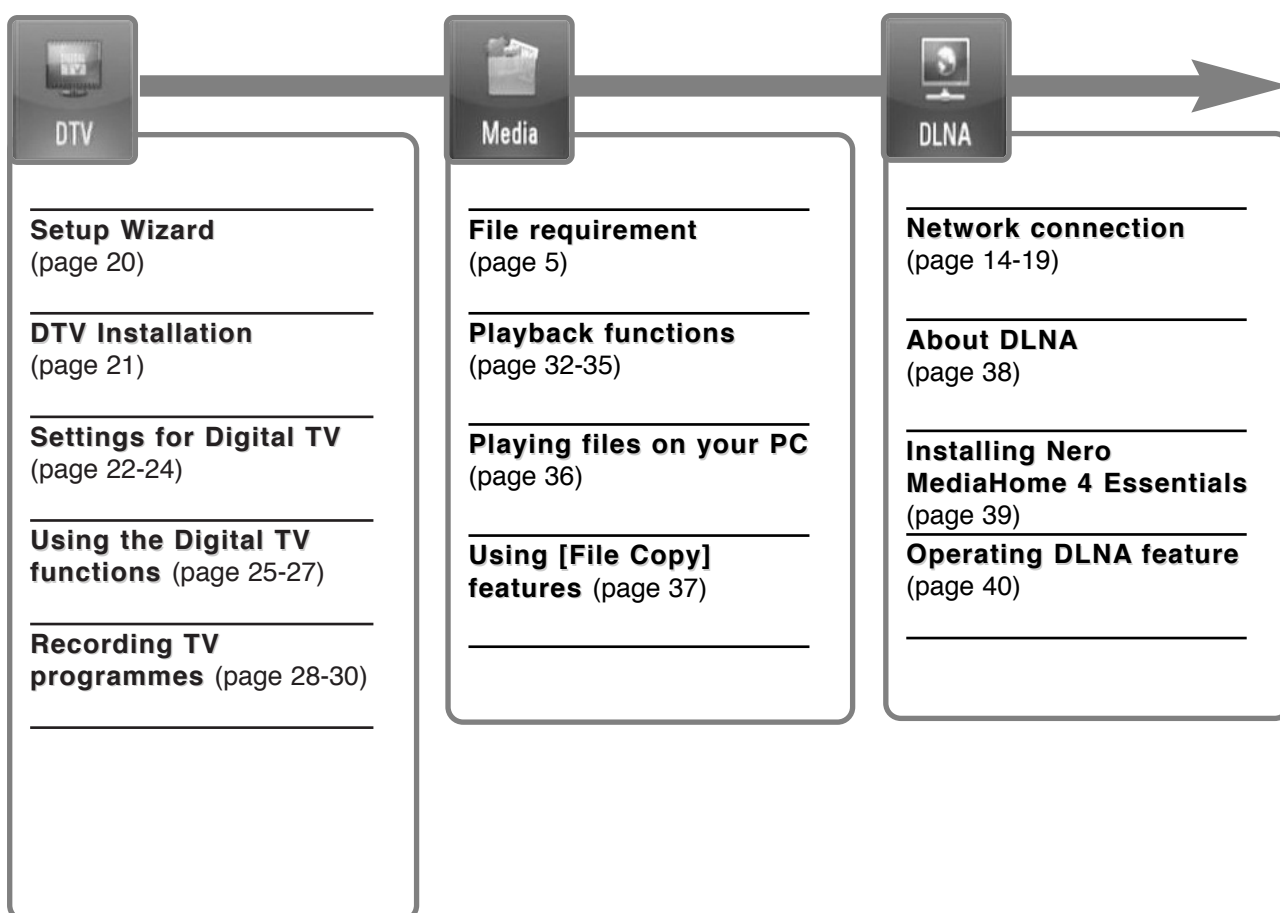

Basic button operations

- **HOME** : Accesses or removes the HOME menu.
- **◀/▶** : Used to navigate on-screen displays.
- **OK (⊙)**: Acknowledges menu selection.
- **BACK (↶)**: Exits the menu.

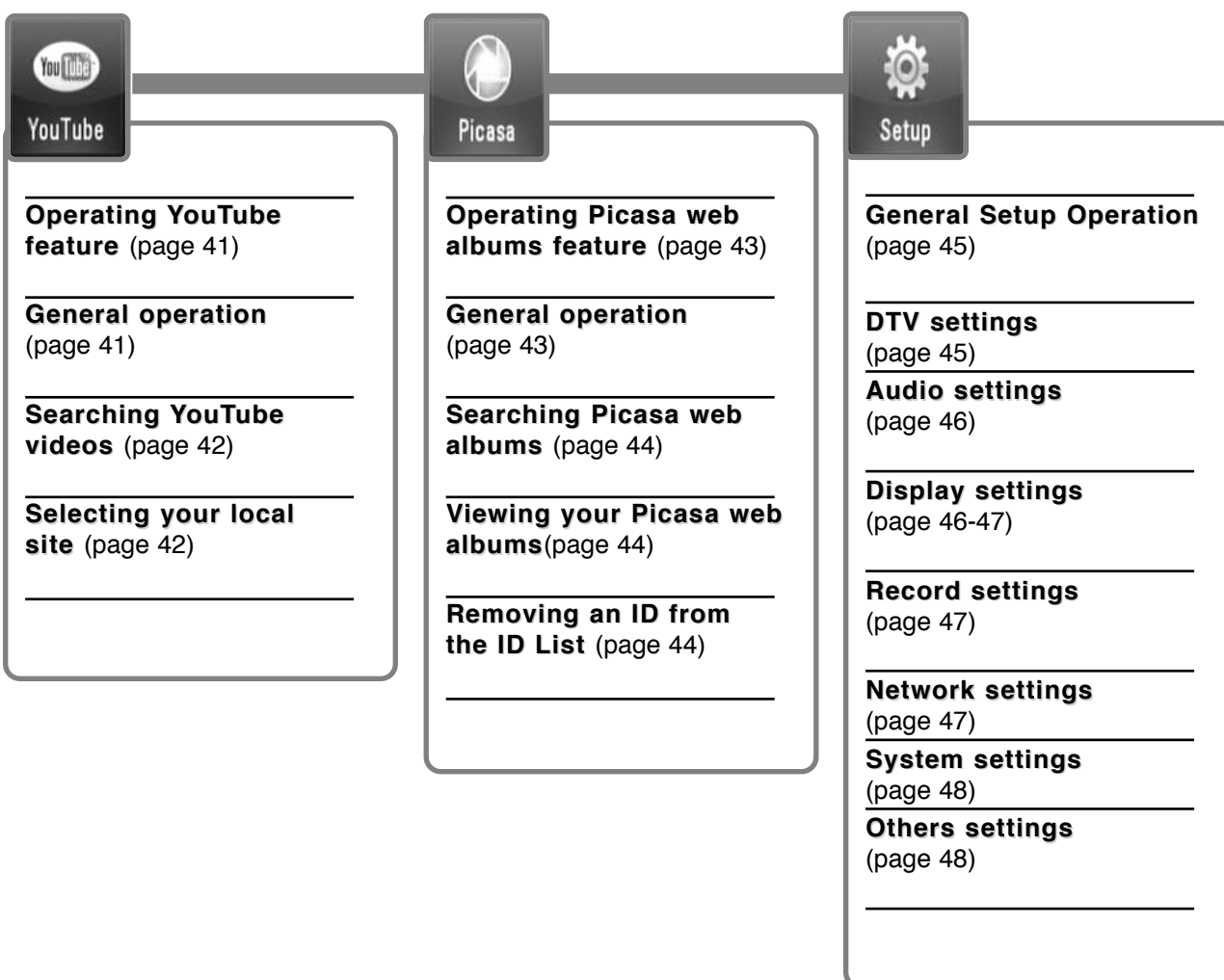

Remote control



POWER (⏻): Switches the recorder ON or OFF.

*: Feature is not available.

VOL (- / +): Adjusts the sound level of the recorder.

TV Control Buttons: You can control the programme selection, sound level, input source, and power switch of your TV (see page 52).

0-9 numerical buttons: Selects numbered options in a menu.

REC (●): Starts recording and copying.

TIMESHIFT: Pauses live TV/playback (timeshift) for a live TV programme.

◀ / ▶ (SCAN): Searches backward or forward.

⏮ / ⏭ (SKIP): Goes to next or previous track/file.

⏸ (PAUSE): Pauses playback.

▶ (PLAY): Starts playback.

■ (STOP): Stops playback.

HOME: Accesses or removes the HOME menu.

GUIDE: Displays the EPG menu.

◀ / ▶ / ▲ / ▼ (left/right/up/down): Navigates on-screen displays.

OK (⊙): Acknowledges menu selection or displays the programme list.

BACK (↶): Exits the menu or back to previous step.

INFO (i): Displays or exits On-Screen Display.

PR (▲ / ▼): Scans up or down through memorized programmes.

PAGE (▲ / ▼): Moves to next or previous page of contents/TV list.

REPEAT: Repeats a desired section or sequence.

ZOOM: Displays or exits the [ZOOM] menu.

MARKER (✓): Used for selecting multiple files or folders in certain operation.

EDIT: Displays an editing menu

Coloured buttons: Used for [MOVIE], [PHOTO] and [MUSIC] menu or when an EPG screen is displayed. The function of each button will be described on-screen, and changes depending on the screen being displayed.

PR LIST: Displays the programme list.

FAV: Displays the favorite programme list.

AUDIO (🔊): Selects an audio language or audio channel.

SUBTITLE (🗣️): Selects a subtitle language.

TIMER REC: Display [Timer Recording] menu.

TEXT: Switches between teletext mode and normal TV viewing.

GOTO: Displays the time search option during movie playback.

RESOLUTION: Sets the output resolution for HDMI and COMPONENT VIDEO OUT jacks. (This key only work is TV watching mode or Home Menu mode.)

Main unit

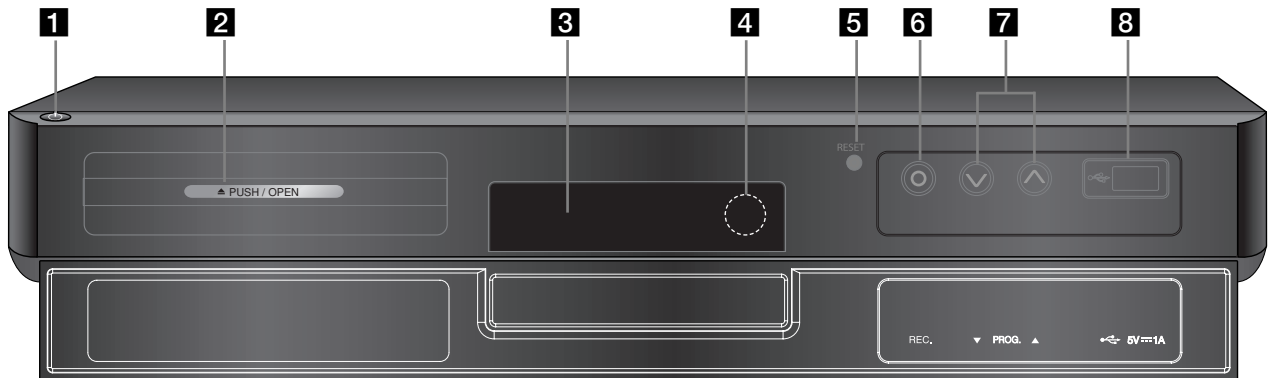

- 1** **⏻ (POWER) Button**
Switches the recorder ON or OFF.
- 2** **External HDD Slot**
Mounting an additional HDD here.
- 3** **Display window**
Shows the current status of the recorder.
- 4** **Remote Sensor**
Point the remote control here.
- 5** **RESET**
Press this button to reboot.
- 6** **● (REC.)**
Starts recording.
- 7** **PROG. ▲/▼**
Scans up or down through memorized programmes.
- 8** **USB Port**
Connect a USB Device.

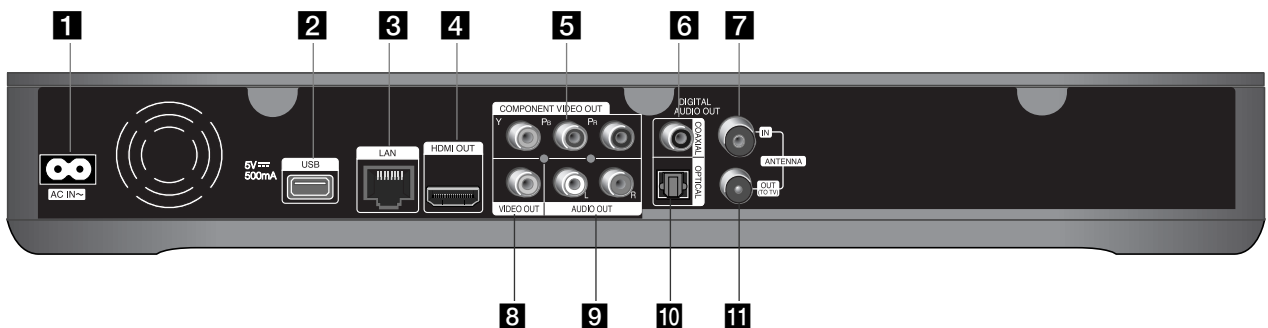

- 1** **AC IN connector**
Connect the supplied power cord.
- 2** **USB Port**
Connect the supplied Wireless LAN Adapter.
- 3** **LAN port**
Connect a network with an always-on broadband connection.
- 4** **HDMI OUT**
Connect to TV with HDMI inputs. (Interface for digital audio and video)
- 5** **COMPONENT VIDEO OUT (Y Pb Pr)**
Connect to a TV with Y Pb Pr inputs.
- 6** **DIGITAL AUDIO OUT (COAXIAL)**
Connect to digital (coaxial) audio equipment.
- 7** **ANTENNA IN**
Connect the antenna to this terminal.
- 8** **VIDEO OUT**
Connect to a TV with video inputs.
- 9** **AUDIO OUT (Left/Right)**
Connect to a TV with audio inputs.
- 10** **DIGITAL AUDIO OUT (OPTICAL)**
Connect to digital (optical) audio equipment.
- 11** **ANTENNA OUT (TO TV)**
Passes the signal from the ANTENNA IN jack to your TV/monitor

Connection overview



- Depending on your TV and other equipment you wish to connect, there are various ways you could connect the recorder. Use only one of the connections described on pages 11-13.
- Please refer to the manuals of your TV, Stereo System or other devices as necessary to make the best connections.

Be sure to switch off the recorder before installation and connection.

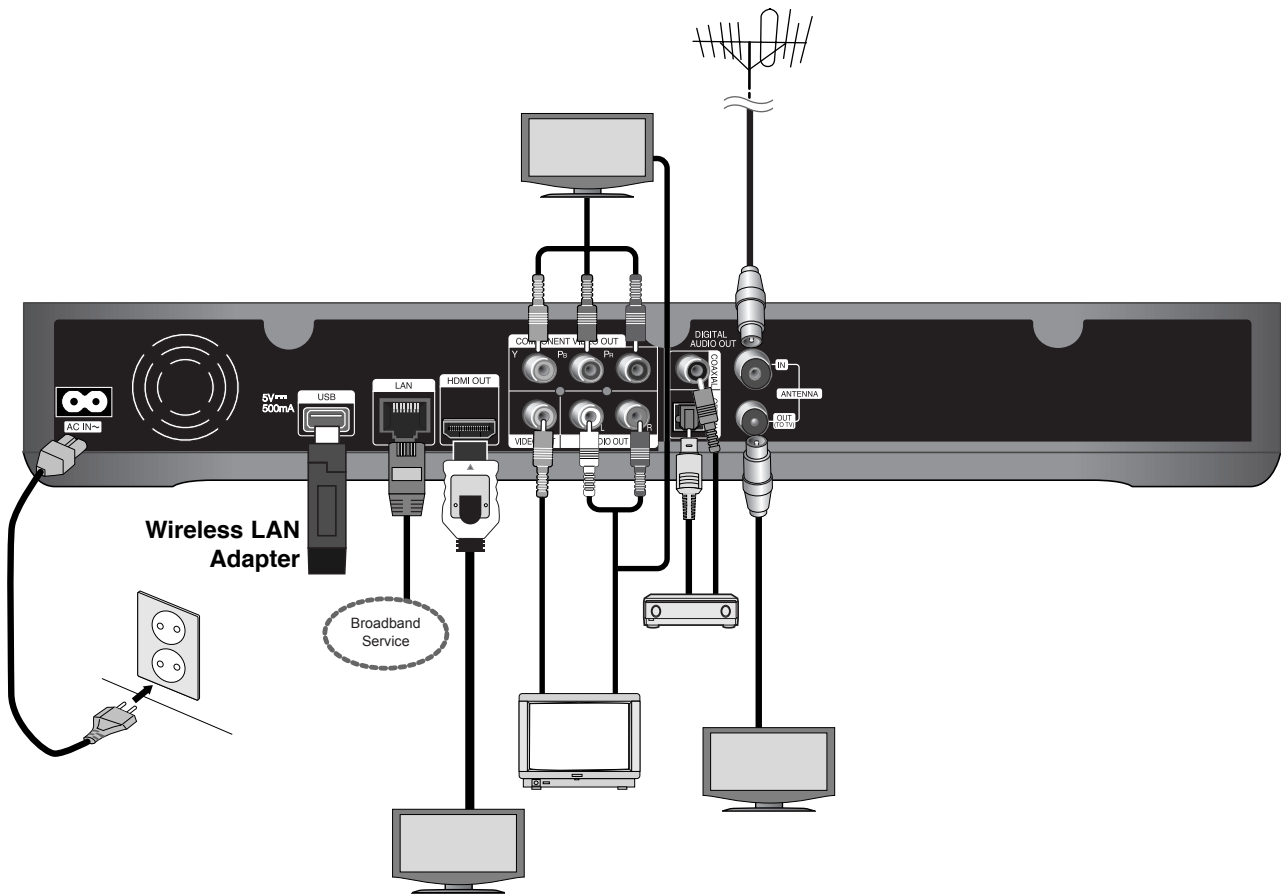

Connections to Your TV

Make one of the following connections, depending on the capabilities of your existing equipment. **Connect to your TV with option A, B or C.**

Caution

- Make sure the recorder is connected directly to the TV. Tune the TV to the correct video input source.
- Do not connect the recorder's AUDIO OUT jack to the phono in jack (record player) of your audio system.
- Do not connect your recorder via your VCR. The image could be distorted by the copy protection system.

(Option A) Best quality - HDMI connection (includes audio and video)

If you have a HDMI TV or monitor, you can connect it to this recorder using a HDMI cable . Connect the HDMI jack on the recorder to the HDMI jack on a HDMI compatible TV or monitor. Set the TV's source to HDMI (refer to TV's Owner's manual).

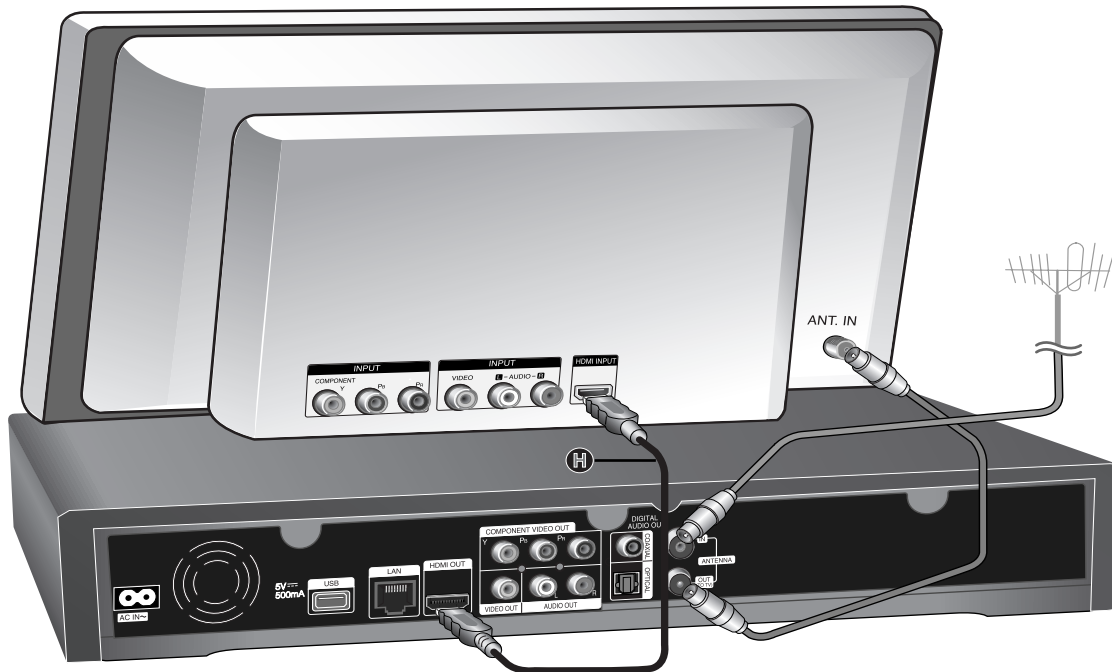

- You must select a HDMI audio output and a maximum sampling frequency that your TV accepts using [Digital Output] option on the [Setup] menu (see page 47).
- If a connected HDMI device does not accept the audio output of the recorder, the HDMI device's audio sound may be distorted or may not output.



- When you use HDMI connection, you can change the resolution for the HDMI output by pressing RESOLUTION button in TV watching mode or in Home Menu mode.

Caution

- Changing the resolution when the connection has already been established may result in malfunctions. To solve the problem, turn off the recorder and then turn it on again.
- When the HDMI connection with HDCP is not verified, TV screen is changed to black screen. In this case, check the HDMI connection, or disconnect the HDMI cable.
- If there is noise or lines on the screen, please check the HDMI cable (length is generally limited to 4.5m).

Additional Information for HDMI

- When you connect a HDMI or DVI compatible device make sure of the following:
 - Try switching off the HDMI/DVI device and this recorder. Next, switch on the HDMI/DVI device and leave it for around 30 seconds, then switch on this recorder.
 - The connected device's video input is set correctly for this unit.
 - The connected device is compatible with 720x576p, 1280x720p, 1920x1080i or 1920x1080p video input.
- Not all HDCP-compatible HDMI or DVI devices will work with this recorder.
 - The picture will not be displayed properly with non-HDCP device.
 - This recorder does not playback and TV screen is changed to black screen.

(Option B) Excellent quality - Component video and stereo audio connection

Connect the COMPONENT VIDEO OUT jacks on the Recorder to the corresponding input jacks on the TV using Y Pb Pr cables **C**. Connect the left and right AUDIO OUT jacks of the Recorder to the audio left and right IN jacks on the TV using the audio cables **A**.

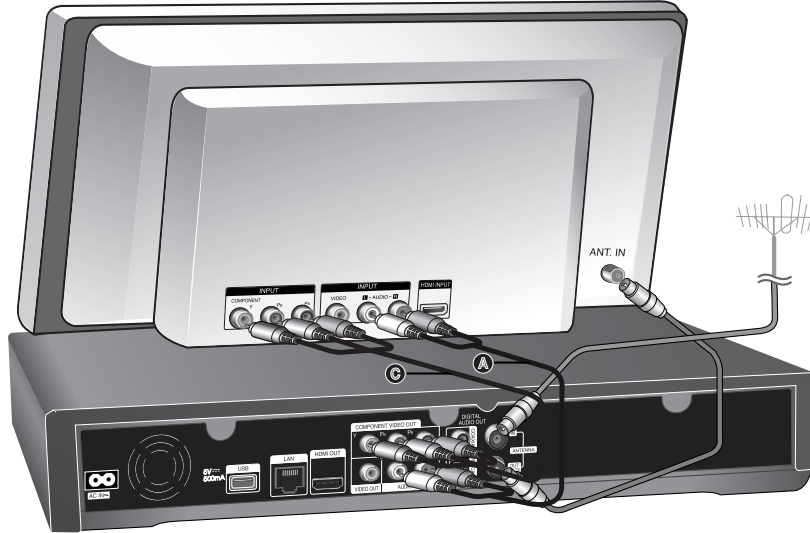

When you cannot use the screen, you can change resolution for the component VIDEO OUT by pressing RESOLUTION button in TV watching mode or in Home menu mode (Refer to "Resolution setting" on page 46.)

(Option C) Connections to your TV (Composite)

Connect the VIDEO OUT jack on the Recorder to the video in jack on the TV using the video cable supplied **V**. Connect the Left and Right AUDIO OUT jacks on the Recorder to the audio left/right in jacks on the TV using the supplied audio cables **A**.

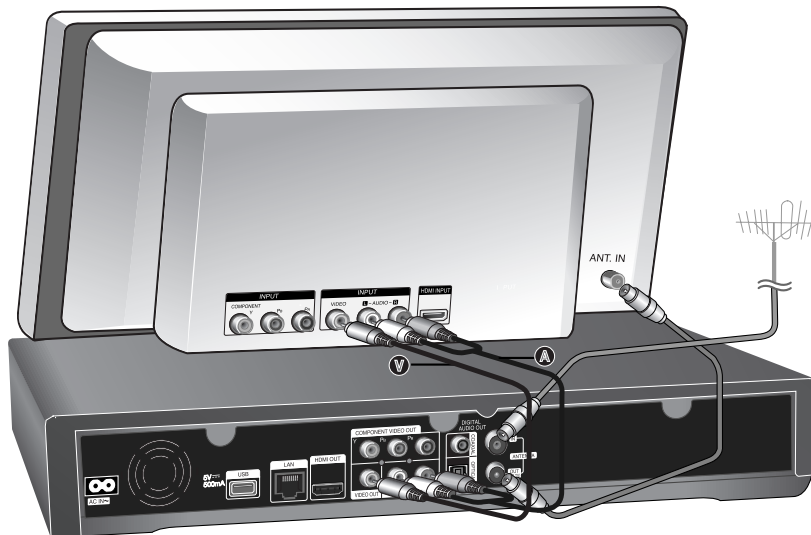

If you use this connection, set the TV's source selector to VIDEO.

Connecting to an Amplifier

Make one of the following connections, depending on the capabilities of your existing equipment.

Connecting to an Amplifier via 2 Channel Audio Output

Connect the Left and Right 2CH AUDIO OUT jacks (A) on the player to the audio left and right in jacks on your amplifier, receiver, or stereo system, using audio cables.

Connecting to an Amplifier via Digital Audio Output (Optical or Coaxial)

Connect the player's DIGITAL AUDIO OUT (OPTICAL or COAXIAL) jack to the corresponding in jack (OPTICAL O or COAXIAL X) on your amplifier. Use an optional digital (optical O or coaxial X) audio cable. You will need to activate the unit's digital output. (See "[Audio] Menu" on page 46.)

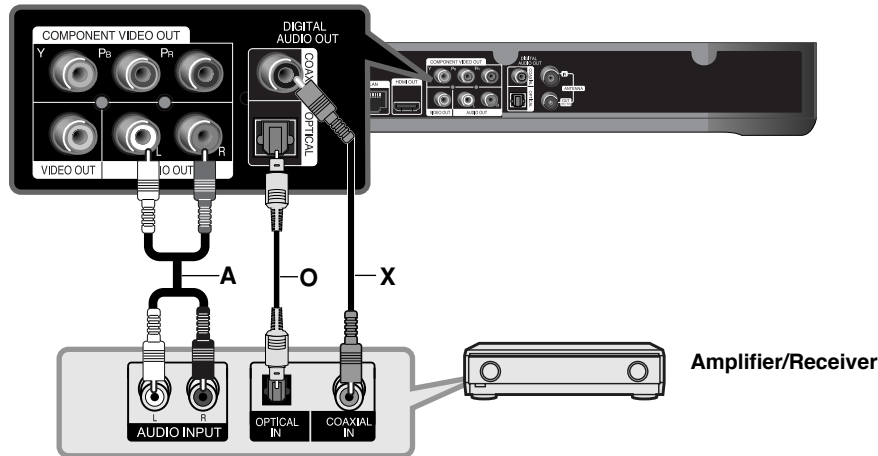

Connecting to an Amplifier via HDMI Output

Connect the unit HDMI OUT jack to the corresponding in jack on your amplifier. Use a HDMI cable (H1). You will need to activate the player's digital output. (See "[Audio] Menu" on page 46.)

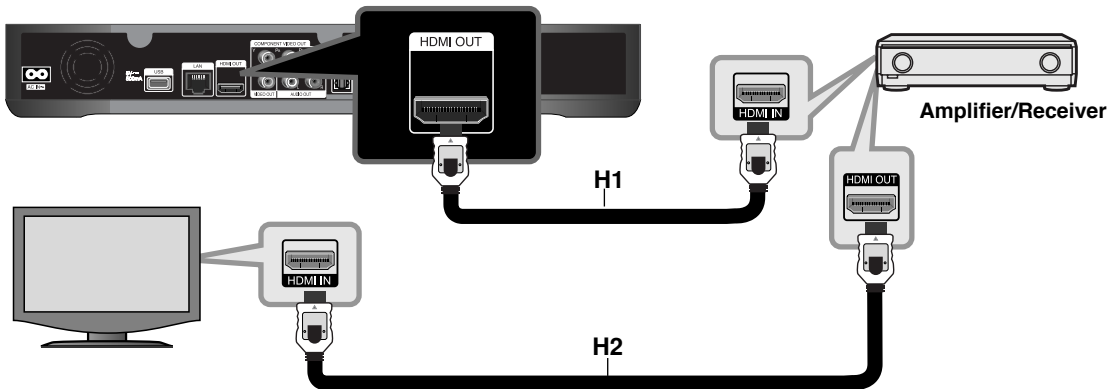

Digital Multi-channel sound

A digital multi-channel connection provides the best sound quality. For this you need a multi-channel Audio/Video Receiver that supports one or more of the audio formats supported by your player. Check the receiver manual and the logos on the front of the receiver. (LPCM, Dolby Digital and DTS)



Connect the amplifier's HDMI output jack to HDMI input jack on your TV using a HDMI cable (H2) if your amplifier has HDMI output jack.

Network connection

This recorder can be connected to the local area network (LAN) via the LAN port or the wireless LAN adapter. Be sure to set the network configuration before using this recorder. You can use the wired and/or wireless network depending on your network environment.

Wired network connection

Using a wired network provides the best performance, because the attached devices connect directly to the network and are not subject to radio frequency interference.

Please refer to the documentation for your network device for further instructions.

The following connection example explain how to connect to the internet using LAN cable.

If you want to access content from PCs or DLNA servers, this recorder must be connected to the same local area network with them via a router.

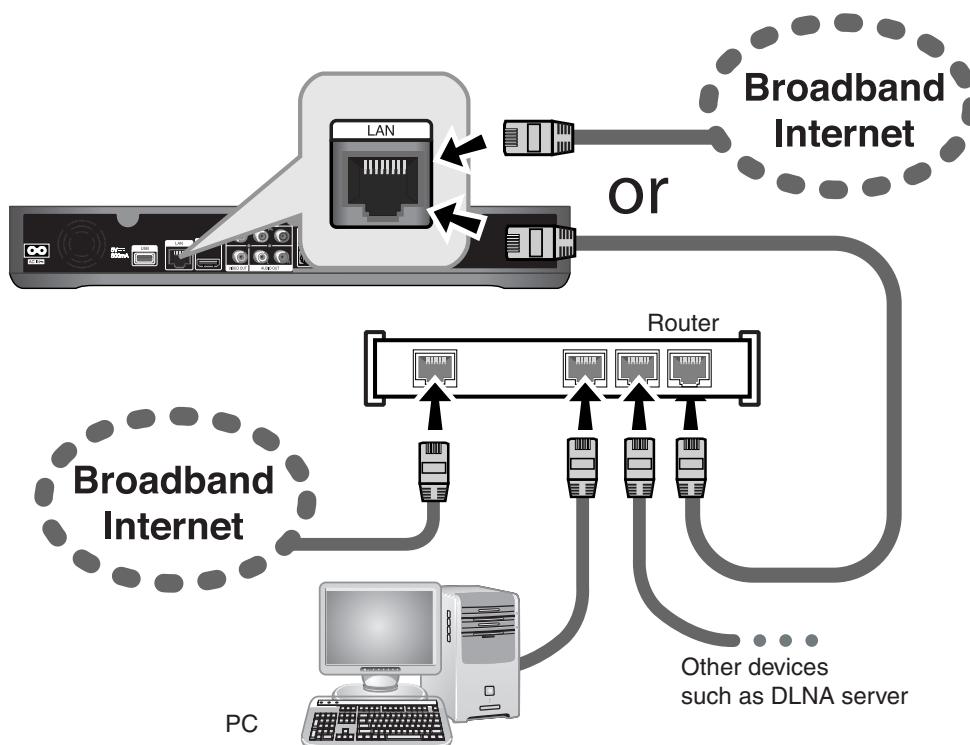

Caution

- When plugging or unplugging the LAN cable, hold the plug portion of the cable. When unplugging, do not pull on the LAN cable but unplug while pressing down on the lock.
- Do not connect a modular phone cable to the LAN port.
- Since there are various connection configurations, please follow the specifications of your telecommunication carrier or internet service provider.

Wired network setting (Auto)

If there is a DHCP server on the local area network (LAN) via wired connection, this recorder will automatically be allocated an IP address.

Preparation:

Before setting the wired network, you need to:
– connect the broadband internet to your home network.

- 1 Press HOME.
- 2 Use ◀/▶ to select the [Setup], and press OK.
- 3 Use ◀/▶ to select the [Network] option.
- 4 Use ▲/▼ to select the [Wired LAN Setup], and press OK.
- 5 Use ▲/▼ to select the [Auto], and press OK.

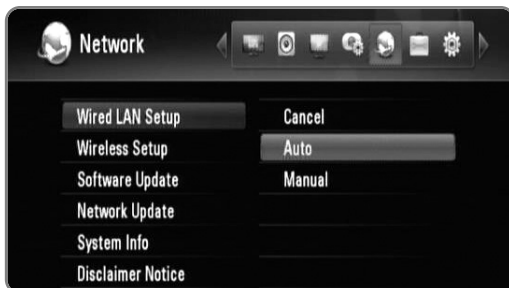

- If you want to set the IP address of the DNS server, use ▲/▼/◀/▶ to select the [DNS server IP address] field and input the IP address using numerical buttons.

- 6 Use ▲/▼ to select the [OK], and press OK.

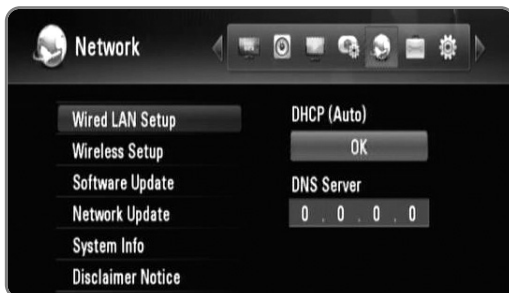

- 7 Use ◀/▶ to select the [OK], and press OK.



Wired network setting (Manual)

If there is no DHCP server on the network and you want to set the network manually, follow the instructions as below.

- 1 Follow the steps 1-3 from “Wired network setting (Auto)” on page 15.
- 2 Use ▲/▼ to select the [Wired LAN Setup], and press OK.

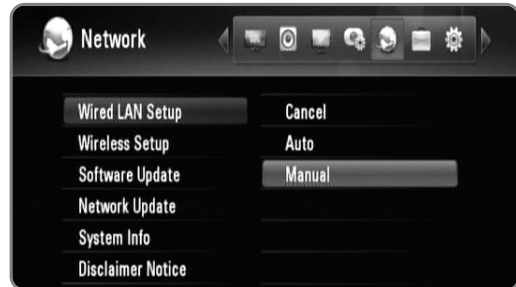

- 3 Use ▲/▼/◀/▶ to move to the [IP Address], [Subnet Mask], [Gateway] and [DNS Server] fields, and fill them using numerical buttons.



- 4 Press OK when you finish inputting all the network information.
- 5 Use ◀/▶ to select the [OK], and press OK.



Wireless network connection

Another network connection is using the supplied wireless adapter.

This recorder supports an IEEE 802.11n wireless module using supplied wireless LAN adapter, which also supports the 802.11b/g standards. For the best wireless performance, we recommend the use of a IEEE 802.11n certified Wi-Fi network (access point or wireless router).

Refer to the setup instructions supplied with your access point or wireless router for detailed connection steps and network settings.

The following connection example explain how to connect to the internet using an access point or wireless router.

If you want to access content from PCs or DLNA servers, this recorder must be connected to the same local area network with them via a wireless network device.

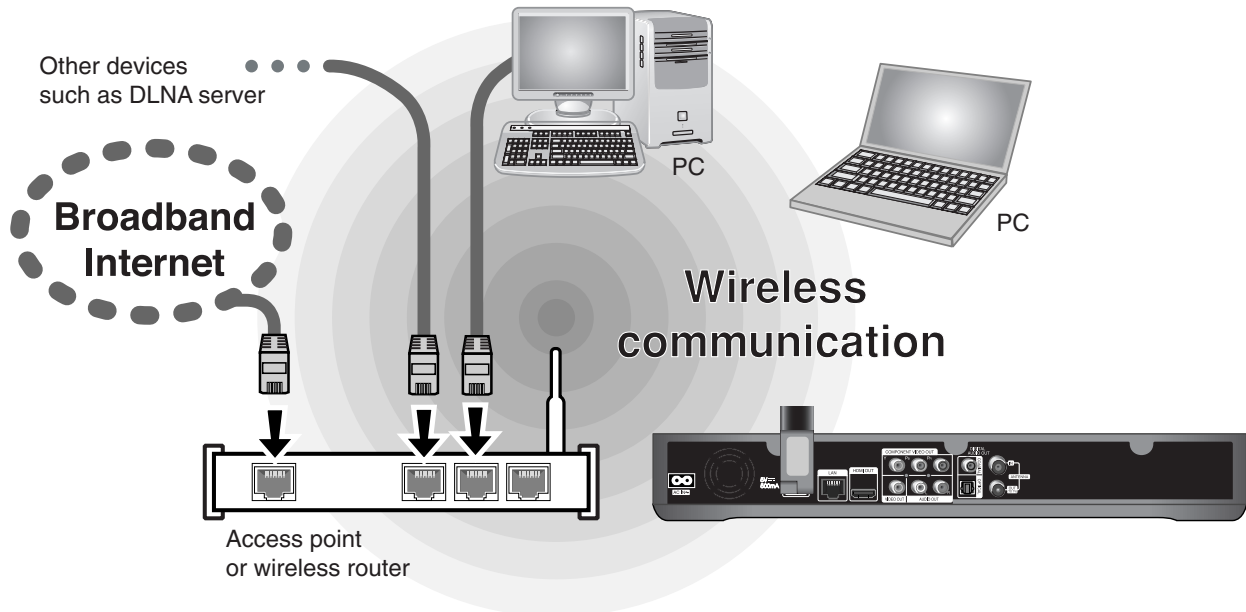

If you do not have a wireless network at your home, you can connect directly to the wireless network equipped computer using peer to peer (Ad-Hoc) setting.

Refer to page 18 for more information of peer to peer connection.



Caution

Using wireless network can be affected by the household devices using radio frequencies. Therefore, operating quality may not good with wireless network connection. Wired network connection is strongly recommended.

Wireless LAN adapter connection

- 1 Connect the supplied wireless LAN adapter to the USB port on the rear panel.

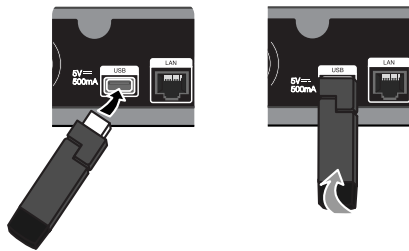

- 2 Fold the wireless LAN adapter to the upper direction.

Wireless network setting (Infrastructure)

If there is a DHCP server on the local area network (LAN) via wired connection, this recorder will automatically be allocated an IP address.

Preparation:

Before setting the wireless network, you need to:

- connect the broadband internet to the wireless home network.
- connect the wireless LAN adapter on the USB port.
- set the access point or wireless router.
- note the SSID and security code of the network.

- 1 Press HOME.
- 2 Use ◀/▶ to select the [Setup], and press OK.
- 3 Use ◀/▶ to select the [Network] option.
- 4 Use ▲/▼ to select the [Wireless Setup], and press OK.



- 5 Use ▲/▼ to select a [Profile Name], and press OK.



- A maximum of 3 profile names can be set for the wireless network setup.
- 6 Use ▲/▼ to select the [Infrastructure (AP)], and press OK.
 - The recorder scans for all of the available access points or wireless routers within range and displays them as a list.
 - 7 Use ▲/▼ to select a SSID, and press OK.



If you have security on your access point or wireless router, verify that the WEP or WPA key that was entered into the recorder matches the router's information exactly.

You need to input the security code as necessary.



- Select [Alphabet Capital], [Alphabet Small] or [Symbol], and press OK to change the character set of the virtual keyboard.
 - [Space]: Inserts a space at the cursor position.
 - [Delete]: Delete a previous character at the cursor position.
 - [← →]: Moves cursor to the left or right.
 - [OK]: Complete inputting security code.
 - [Cancel]: Cancels the naming, and return to the previous.
- 8 Check the network information, and press OK to finish the network setup.

Wireless network setting (peer to peer)

If you do not have a wireless network device at your home, you can connect directly to the wireless network equipped computer using [Peer to Peer (Ad Hoc)] setting.

For this connection, features which require internet connection such as YouTube, Picasa web albums cannot be operated.

Preparation:

Before setting the peer to peer connection, you need to:

- connect the wireless LAN adapter on the USB port.
- prepare the wireless network equipped computer.

- 1 Follow the steps 1-5 from “Wireless network setting (Infrastructure)” on page 17.
- 2 Use ▲/▼ to select the [Peer to Peer (Ad Hoc)], and press OK.

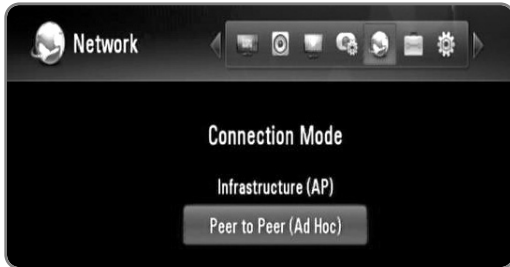

- 3 Use ▲/▼ to select the [Wireless SSID], and press OK to display the virtual keyboard.



- Select [Alphabet Capital], [Alphabet Small] or [Symbol], and press OK to change the character set of the virtual keyboard.
- [Space]: Inserts a space at the cursor position.
- [Delete]: Delete a previous character at the cursor position.
- [← →]: Moves cursor to the left or right.
- [OK]: Complete inputting SSID.
- [Cancel]: Cancels the naming, and return to the previous.

- 4 If you want to set the security, use ▲/▼ to select the [Shared key (WEP)], and press OK to display the virtual keyboard.
 - Refer to step 3 above for using virtual keyboard.
 - If you do not want to set the security for the wireless connection, select the [Open System], and press OK.
- 5 Use ▲/▼ to select the [Host IP] field, and input the IP address using numerical buttons.
 - Using default IP address is recommended.
- 6 Press yellow coloured button to complete the [Ad-Hoc Setup] settings.
- 7 Check the network information, and press OK to finish the network setup.
- 8 On your computer, the SSID you have set can be found on the wireless network list.
 - Please refer to the documentation for your computer or operating system for further instructions.



- There may be various ways to get Ad-Hoc connection to your computer depending on the operating system, wireless network application,

Notes on Network Connection

- Many network connection problems during set up can often be fixed by re-setting the router or modem. After connecting the recorder to the home network, quickly power off and/or disconnect the power cable of the home network router or cable modem. Then power on and/or connect the power cable again.
- Depending on the internet service provider (ISP), the number of devices that can receive internet service may be limited by the applicable terms of service. For details, contact your ISP.
- Our company is not responsible for any malfunction of the recorder and/or the internet connection feature due to communication errors/ malfunctions associated with your broadband internet connection, or other connected equipment.
- Some internet contents may require a higher bandwidth connection.
- Even if the recorder is properly connected and configured, some internet contents may not operate properly because of internet congestion, the quality or bandwidth of your internet service, or problems at the provider of the content.
- Some internet connection operations may not be possible due to certain restrictions set by the Internet service provider (ISP) supplying your broadband Internet connection.
- Any fees charged by an ISP including, without limitation, connection charges are your responsibility.
- A10 Base-T or 100 Base-TX LAN port is required for wired connection to this recorder. If your internet service does not allow for such a connection, you will not be able to connect the recorder.
- You must use a Router to use xDSL service.
- ADSL modem is required to use DSL service and a cable modem is required to use cable modem service. Depending on the access method of and subscriber agreement with your ISP, you may not be able to use the internet connection feature contained in this recorder or you may be limited to the number of devices you can connect at the same time. (If your ISP limits subscription to one device, this recorder may not be allowed to be connected when a PC is already connected.)
- The use of a "Router" may not be allowed or its usage may be limited depending on the policies and restrictions of your ISP. For details, contact your ISP directly.
- The wireless network operate at 2.4GHz radio frequencies that are also used by other household devices such as cordless telephone, *Bluetooth*® devices, microwave oven, and can be affected by interference from them.
- Turn off all unused network equipment in your local home network. Some devices may generate network traffic.
- For the purpose of better transmission, place the recorder as close as possible to the access point.
- In some instances, placing the access point or wireless router at least 1.5 ft (0.45m) above the floor may improve the reception.
- Move closer to the access point if possible or re-orient the recorder so there is nothing between it and the access point.
- The reception quality over wireless depends on many factors such as type of the access point, distance between the recorder and access point, and the location of the recorder.
- ADSL modem is required to use DSL service and a cable modem is required to use cable modem service. Depending on the access method of and subscriber agreement with your ISP, you may not be able to use the internet connection feature contained in this recorder or you may be limited to the number of devices you can connect at the same time. (If your ISP limits subscription to one device, this recorder may not be allowed to connect when a PC is already connected.)
- The use of a "Router" may not be allowed or its usage may be limited depending on the policies and restrictions of your ISP. For details, contact your ISP directly.
- Your ISP may protect this recorder from being connected to network when confirming MAC ADDRESS. In that case, contact your ISP to request to initialize MAC ADDRESS.



Setup Wizard (Initial install)

After turning on the recorder for the first time or after resetting the recorder, the Setup Wizard menu is displayed.

You can set the display language, region, programme scan, time and network setup on the [Setup Wizard] menu.

- 1 Use ▲/▼ to select a language for the on-screen display, and press OK.



- 2 Use ▲/▼ to select a region, and press OK.

- 3 Use ▲/▼ to select the [OK], and press OK to begin programme scanning. The recorder automatically searches for and saves the programmes.



If you select [Cancel], the [Auto Programming] function will be skipped.

- 4 Use ▲/▼ to select an option among [Cancel], [Manual] or [Auto], and press OK.

Auto: Set the programme that broadcasts a clock signal and the clock will be set automatically.

If the time that has automatically set is not correct comparing your local time, you can set additional time option. Select your region in the [Time Zone] option to set a time relative to area. If the summer time has started in your region, select the [Time Offset] option and increase or decrease time using ◀/▶.



Manual: If there is no channel that broadcasts a clock signal in your area, you can set the time and date manually. Use ◀/▶ to select each field, and input correct time and date using ▲/▼.



- 5 Press OK to complete the [Time] setting.

- 6 Refer to “Wired network connection” on page 14-15 to complete the [Wired LAN Setup] option, and press OK.
 - Select [Cancel] and press OK to cancel.

- 7 Refer to “Wireless network connection” on page 16-18 to complete the [Wireless Setup] option, and press OK.

- Select [Cancel] and press OK to cancel.
- This recorder can apply only one network setup between [Wired LAN setup] and [Wireless Setup]. If you already set the [Wired LAN setup] at step 6, you do not need to set [Wireless Setup] setting.



- You can reset the Setup Wizard from the [Initialization] in the setup menu. (see page 48).
- The [Initialization] option is not available while recording or [Lock System] in the [Setup] menu is set to [On].



DTV

DTV Installation

Connect the DTV antenna to the ANTENNA IN jack on the rear panel as described below.

And connect the ANTENNA OUT jack on the rear panel to the ANTENNA IN jack on your TV using RF cable.

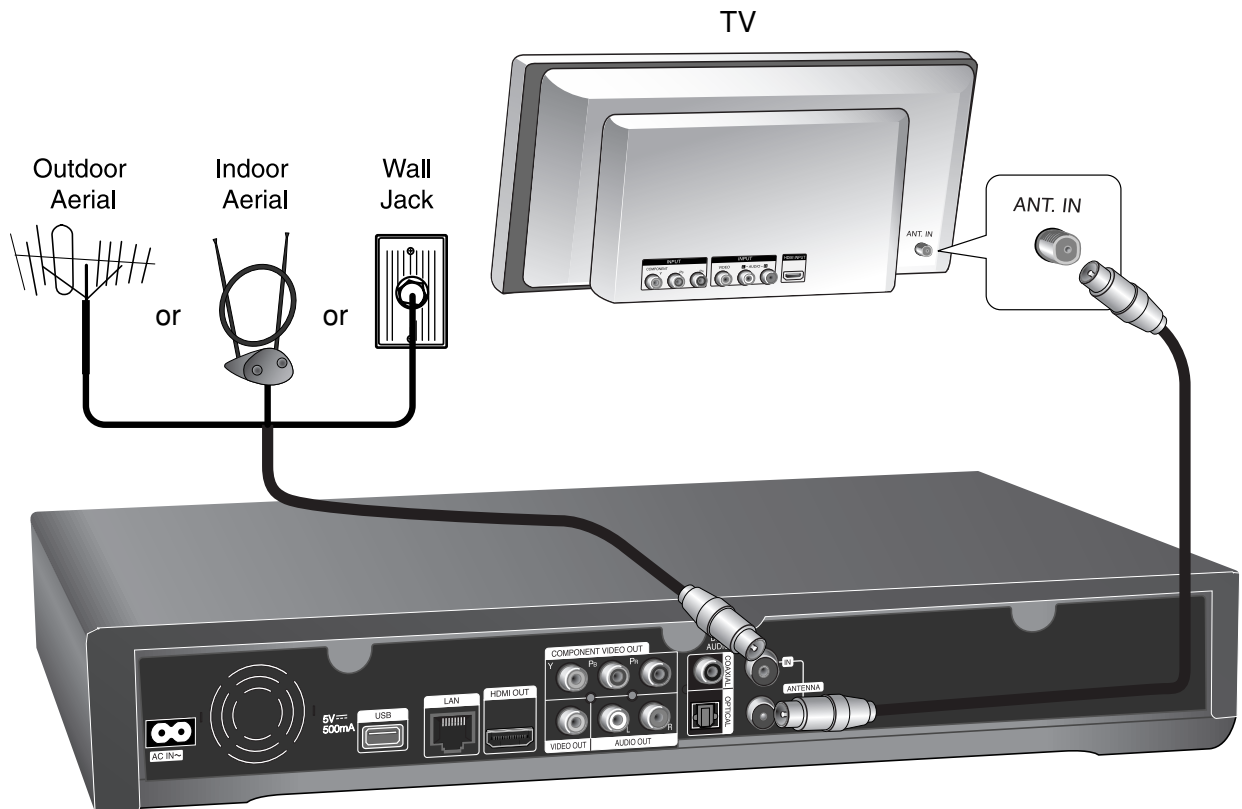

If you are using an indoor antenna, use one with a signal amplifier rated at DC 5V, 100mA and set "Antenna Feed 5V" option to [ON] on the setup menu. (see page 24)

Caution

The [Antenna Feed 5V] option must be set to [Off] when your indoor antenna is supplied the power from the mains. If you set [Antenna Feed 5V] option to [On] for the indoor antenna which is supplied power from the mains, it may cause serious defect to this recorder.

Settings for Digital TV

To use DTV functions, this recorder needs some settings in advance. You can make settings and adjustments using the [Setup wizard] menu. (refer to page 20 for details). You can also set them manually as below.

Selecting a Region

Select a region where you operate this recorder.

- 1 Press HOME.



- 2 Use ◀/▶ to select the [Setup], and press OK.



- 3 Use ◀/▶ to select the [DTV] option.
- 4 Use ▲/▼ to select the [Region] and press OK.
- 5 Use ▲/▼ to select a region where you operate this recorder, and press OK.



If the [Lock] option is set to [On], this function is not available (page 23).

Scanning programmes automatically

All available digital TV or radio programmes are searched and stored automatically based on the selected region.

- 1 Follow the steps 1-3 from “Selecting a Region” on page 22.
- 2 Use ▲/▼ to select the [Auto Programming] and press OK.
- 3 Use ▲/▼ to select the [Auto Scan] and press OK to start the programme scanning.
 - Select [Cancel] and press OK to cancel.



- This option is not available while recording or the [Permanent Timeshift] option is the [Setup] menu is set to [On].
- If the [Lock] option is set to [On], this function is not available (page 23).

Scanning programmes manually

Scans digital TV or radio programmes and adds the found programmes to the programme list.

- 1 Follow the steps 1-3 from “Selecting a Region” on page 22.
- 2 Use ▲/▼ to select the [Auto Programming] and press OK.
- 3 Use ▲/▼ to select the [Manual Scan] and press OK to display the [Manual Scan] menu.
 - Select [Cancel] and press OK to cancel.

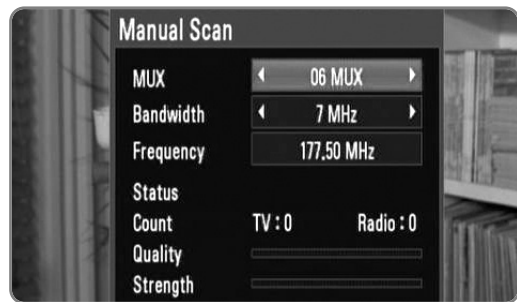

- 4 Use ◀/▶ to select the desired multiplexer (MUX), and press OK to start scanning.

OR

If you know the programme bandwidth and frequency, use ◀/▶ to select the desired [Bandwidth], and Fill the [Frequency] field using numerical buttons.

- 5 Press OK to start programme scanning.



- This option is not available while recording or the [Permanent Timeshift] option is the [Setup] menu is set to [On].
- If the [Lock] option is set to [On], this function is not available (page 23).

Editing Programme List

You can remove any digital TV or radio programs stored on this recorder using [Program edit] menu.

- 1 Follow the steps 1-3 from “Selecting a Region” on page 22.
- 2 Use ▲/▼ to select the [Program Edit] and press OK.
- 3 Use ▲/▼ to select the [DTV] and press OK to display the [Edit - TV] menu.
 - Select [CANCEL] and press OK to cancel.



- 4 Press yellow coloured button to toggle list between TV and RADIO programme list.



- [Edit - TV] or [Edit - Radio] menu shows the signal strength (📶) and quality (🌟) of the current programme at the bottom.
- 5 Use ▲/▼ to select a programme you want to delete from the list, and press blue coloured button.
 - If you do not want to remove the programme, select [No] and press OK on the popup menu.
 - 6 Press BACK to return to the [Setup] menu.



This option is not available while recording or the [Permanent Timeshift] option is the [Setup] menu is set to [On].

Setting the Lock System

Allows you to activate or deactivate all of the lock schemes previously set. When the [Lock System] is set to [Off], the [TV Rating] option is not effective.

- 1 Follow the steps 1-3 from “Selecting a Region” on page 22.
- 2 Use ▲/▼ to select the [Parental Guidance] and press OK.
- 3 Input the password using numerical buttons.
 - If you have not set your password yet, input “0000”.
- 4 Use ▲/▼ to select the [Lock System] and press OK.

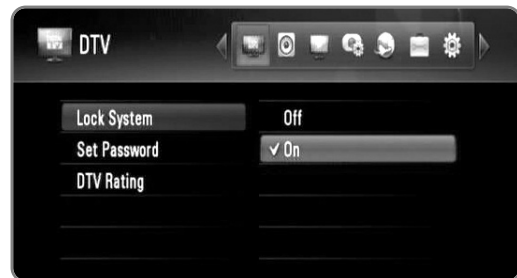

- 5 Use ▲/▼ to select the [On] and press OK to activate the parental lock.

Setting a new password

You can set or change your password.

- 1 Follow the steps 1-3 from “Selecting a Region” on page 22.
- 2 Use ▲/▼ to select the [Parental Guidance] and press OK.
- 3 Input the password using numerical buttons.
 - If you have not set your password yet, input “0000”.
- 4 Use ▲/▼ to select the [Set Password] and press OK.



- 5 Enter the current password.
- 6 Enter a new password.
- 7 Enter the new password to verify it.



- This option is not available while recording.
- If you forget your password, you can clear it using the following steps:
 1. Highlight the [Parental Guidance] option in the [Setup] menu.
 2. Use Number buttons to enter “210499”. The password will be set to default password (0000).

Adjusting TV Rating level

Viewing of some digital TV programmes can be limited according to the age limit you set.



If the [Lock System] is set to [Off] in the [Setup] menu, the [DTV Rating] option is not available.

- 1 Follow the steps 1-3 from “Selecting a Region” on page 22.
- 2 Use ▲/▼ to select the [Parental Guidance] and press OK.
- 3 Input the password using numerical buttons.
 - If you have not set your password yet, input “0000”.
- 4 Use ▲/▼ to select the [DTV Rating] and press OK.



- 5 Use ▲/▼ to select the [Parental Guidance].
- 6 use ◀/▶ to set the limitation level and press OK.
 - Select the [No Control] to release the limitation.
 - To watch programmes that exceed the rating level you set, your password is required.
 - Refer to page 45 for more information about rating levels.

Setting the antenna power

If you are using indoor antenna with a signal amplifier rated at DC 5V, 100mA, the recorder can supply power through ANTENNA IN jack.

- 1 Follow the steps 1-3 from “Selecting a Region” on page 22.
- 2 Use ▲/▼ to select the [Antenna Feed 5V] and press OK.
- 3 Use ▲/▼ to select the [On], and press OK to supply antenna power.

Caution

The [Antenna Feed 5V] option must be set to [Off] when your indoor antenna is supplied the power from the mains. If you set the [Antenna Feed 5V] option to [On] for the indoor antenna which is supplied power from the mains, it may cause serious defect to this recorder.

Setting the permanent Timeshift

You can set the Time Shift function automatically without pressing TIMESHIFT button. The timeshift will start after Digital TV tuner mode is started.

- 1 Press HOME.
- 2 Use ◀/▶ to select the [Setup], and press OK.
- 3 Use ◀/▶ to select the [Record] option.



- 4 Use ▲/▼ to select the [Permanent Timeshift] and press OK.
- 5 Use ▲/▼ to select the [On] to apply permanent timeshift.



This option is not available while recording.

Setting a recording storage location

You can set the storage location where you want to store the DTV recordings.

- 1 Press HOME.
- 2 Use ◀/▶ to select the [Setup], and press OK.
- 3 Use ◀/▶ to select the [Record] option.
- 4 Use ▲/▼ to select the [REC Device] and press OK.



- 5 Use ▲/▼ to select a storage, and press OK.



This option is not available while recording.

Using the Digital TV functions

You can watch and record the digital TV programmes or play back the recorded TV programmes you want to watch using this recorder.

Viewing the Digital TV

Viewing the Digital TV broadcasting on the TV screen.

Preparation:

- DTV antenna connection is required. (page 21)
- DTV settings such as [Auto Programming], [Parental Guidance] in the [Setup] menu may be required. (page 23)

- 1 Press POWER to turn on the recorder.
- 2 Use ◀/▶ to select [DTV] on the HOME menu and press OK.

Adjusting volume of audio out

Press VOL (-/+) to adjust the sound level of audio output from this recorder.

Changing Digital TV programmes

Generally, press PR (∧ / ∨) or ▲/▼ to select the programme position, or entering a programme number using numerical buttons.

If you want to change the programme on the programme list, follow the instruction as below.

- 1 While watching DTV, press OK or PR LIST.

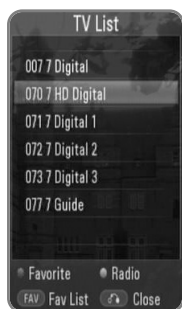

- 2 Press yellow coloured button to toggle menu between [TV List] and [Radio List].
- 3 Use ▲/▼ to select a desired programme, and press OK.
- 4 Press BACK to exit the programme list.

Setting favorite programmes

- 1 While watching DTV, press OK or PR LIST
- 2 Press yellow coloured button to toggle menu between [TV List] and [Radio List].

- 3 Use ▲/▼ to select a programme you want to add on the Favorite List.
- 4 Press red coloured button to set the programme as a favorite programme.
 - The ♥ mark appears for the favorite programmes.
 - To cancel the favorite programmes, select a programme with ♥ mark, and press red coloured button.
- 5 Press FAV to display the favorite programme list.
 - On the Favorite List menu, press yellow coloured button to toggle menu between TV favorite List and Radio favorite List.

Viewing the programme information

You can view description of the programme being broadcast.



- 1 While watching DTV, press INFO to display the programme information.
- 2 Press INFO again to close the programme information.

Selecting DTV audio language

Some digital programmes may broadcast several audio languages or encoding methods. You can select an audio language or an encoding method when it is available.

- 1 While watching DTV, press AUDIO.
- 2 Use ◀/▶ to select an audio language or an encoding method, and press OK.

Selecting DTV subtitle language

Some digital programmes may broadcast several subtitle language. You can select a subtitle language when it is available.

- 1 While watching DTV, press SUBTITLE.
- 2 Use ◀/▶ to select a subtitle language, and press OK.



You can find a programme that supports subtitle language on the programme information. For the programmes with subtitle, **SUB** icon appears on the programme information.

Viewing the EPG (Electronic Programme Guide) Display

The Electronic Programme Guide is a guide showing the programme schedule for a day or more at a time.



Digital Services availability and contents may differ depends on the broadcaster.

- 1 Press GUIDE while watching Digital TV.
 - The EPG screen appears and it updates automatically if the EPG data is acquired successfully.
- 2 Select an item using ◀/▶ and adjust the selected item using ▲/▼.

The adjustable items are **3**, **4** and **5**.



- 1 Shows the Live Digital TV programme that you have chosen on the programme field.
- 2 Indicates the detailed information of the currently selected programme.
- 3 Indicates the currently selected date. Use ▲/▼ to select a different date.
- 4 Indicates the current programme name. Use ▲/▼ to change the programme.
- 5 Indicates the programme guide of the selected programme. Shows the start time, end time and title of the programme.

Using the timeshift function manually

You can pause a Live TV broadcast, then continue watching the programme at a later time. This is useful when you receive an unexpected call or visitor while watching TV.

Followings are operating steps when the [Permanent Timeshift] option is set to [Off].

- 1 Press TIMESHIFT while watching a TV broadcast.
 - The picture pauses, and the recorder starts recording the current TV programme to the internal HDD.
 - Make sure that there is sufficient space on the internal HDD for the timeshift function.
- 2 Press PLAY to resume watching the programme.
 - Press INFO to display the progress of timeshift.
 - Press SKIP (◀◀ / ▶▶) to move the starting point or the ending point of timeshift.
 - Press SCAN (◀◀ / ▶▶) to playback of timeshift fast forward or fast reverse.
 - Press SCAN (▶▶) while in pause mode to slow down the timeshift playback speed. Press SCAN

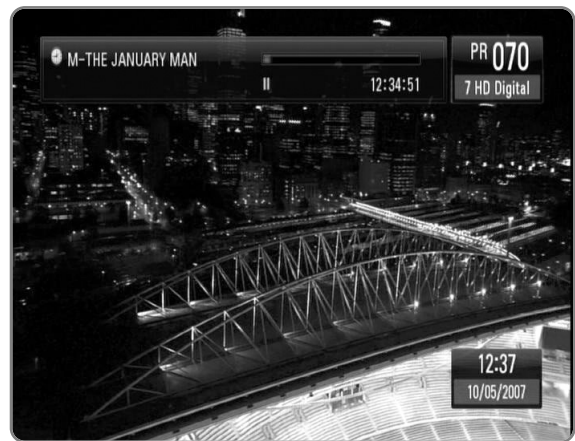

(▶▶) repeatedly to change the playback speed.

- 3 Press STOP to cancel the timeshift.
 - Timeshift cannot be saved as a title.

Using the permanent timeshift

If you set the [Permanent Timeshift] option to [On], live TV broadcast will automatically be recorded to the internal HDD without pressing TIMESHIFT button. The timeshift will start automatically when the Digital TV tuner mode is started.

Refer to “Setting the permanent timeshift” on page 24 to set the [Permanent Timeshift] option.

- 1 Press POWER to turn on the recorder.
- 2 Use ◀/▶ to select [DTV] and press OK.
 - The timeshift function will automatically start.
 - Press SKIP (◀◀/▶▶) to move the starting point or the ending point of timeshift.
 - Press SCAN (◀◀/▶▶) to playback of timeshift fast forward or fast reverse.
 - Press SCAN (▶▶) while in pause mode to slow down the timeshift playback speed. Press SCAN (▶▶) repeatedly to change the playback speed.
- 3 Press HOME to exit from the DTV viewing.

Using the teletext (Viewing Teletext)

Many Digital TV programmes broadcast information via their text service, and this recorder has access to dedicated text programmes transmitted by the broadcasters.



- 1 Press TEXT while watching TV.
- 2 Use red or green coloured button to select a page.
 - You can also select a page by entering a three digit number with the numerical buttons.
- 3 Press TEXT to exit the teletext screen.



Additionally, you now have four coloured buttons to navigate through the content of the page. The use of these coloured buttons will be displayed on the screen.

Recording TV programmes

You can record Digital TV programmes, store it on the internal HDD, external HDD or USB device.

Preparations:

- Select the recording location using [REC Device] option on the SETUP menu. (page 24)
- Connect a USB device, if [REC Device] option is set to [USB].
- You need minimum of 20MB free space on the storage for recording.

Normal Recording

- 1 Use PR (Λ/V) or ▲/▼ to select a programme you want to record.
- 2 Press REC to start recording.
 - Press PAUSE to pause recording, press PAUSE again to resume recording.
 - You can watch another programme while recording.
- 3 Press STOP to stop recording.
 - To stop recording, you must move to the programme being recorded before pressing STOP.



- TV recordings will be stored in the [REC] folder of the storage you've set in the [REC Device].
- Only HDD type USB storages are Available for USB recording. Flash type USB storages are not available for recording.

Dual Programme Recording

You can record two Digital TV programme at the same time.

- 1 Use PR (Λ/V) or ▲/▼ to select a programme you want to record.
- 2 Press REC to start recording.
- 3 Use PR (Λ/V) or ▲/▼ to select another programme you want to record.
- 4 Press REC to start recording.
 - While recording two programmes simultaneously, you can only watch the programmes being recorded.
- 5 Press STOP to stop recording.
 - To stop recording, you must move to the programme being recorded before pressing STOP.

Timer Recording (Manual)

You can set the timer for a total of 32 programmes, up to 30 days in advance.

- 1 While watching TV, press TIMER REC.



- 2 Use ▲/▼ to select [NEW], and press OK.

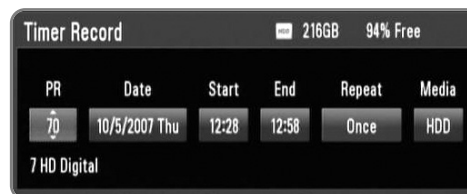

- 3 Select an item using ◀/▶ and adjust it using ▲/▼. The adjustable items are listed below.

PR	Sets the programme position.
Date	Sets the date.
Start	Sets the start time.
End	Sets the end time.
Repeat	Choose a desired repeat mode. (Once, Everyday, Mon-Fri, Mon-Sat or Weekly)
Media	Sets the device to be recorded. HDD: internal HDD HDD+: external HDD



- The timer recording can be set from 3 minutes after the current time.
 - Timer recording is not available on a USB device.
- 4 Press OK and confirm message appears.
 - 5 Select [Confirm] then press OK.
 - If you input the wrong information, an error message will be appeared and the timer recording cannot made. Refer to "Editing a timer recording" on page 30 to edit timer recording.
 - Select [Cancel] and press OK to cancel.

Timer Recording (EPG)

You can also set the timer based on the information provided by the EPG.

- 1 While watching TV, press GUIDE.



- 2 Use ◀/▶ to select date field, and select the date of recording schedule using ▲/▼.
- 3 Use ◀/▶ to select programme field, and set the programme using ▲/▼.
- 4 Use ◀/▶ to select the programme list, and select a programme you want to record using ▲/▼.
- 5 Press REC.
 - For the successfully scheduled programme, a red bullet mark appears.
 - A red bullet mark may not appear for unavailable programme to record.
- 6 Press BACK to return to the TV viewing.
- 7 Press TIMER REC, and check whether the schedule is registered properly or not.



Canceling a timer recording

You can cancel a timer recording before the timer recording actually starts.

- 1 While watching TV, press TIMER REC.
- 2 Use ▲/▼ to select a schedule you want to cancel.
- 3 Press the blue coloured button.
- 4 Use ◀/▶ to select [Delete one], and press OK.
 - Select [Cancel] and press OK to cancel .
 - Select [Delete all] and press OK to delete whole schedules.



Checking the history

You can check if the timer recording is completed or not on the [Timer Record History] menu. The [Result] column shows "OK" or "FAIL".

- 1 While watching TV, press TIMER REC.
- 2 Press yellow coloured button to display the [Timer Record History] menu.
 - To delete a history, select a history and press ENTER. And select [OK] and press OK to delete the history.



Editing a timer recording

You can edit a pre-scheduled timer before the timer recording actually starts.

- 1 While watching TV, press **TIMER REC**.
- 2 Use **▲/▼** to select a schedule you want to edit.
- 3 Press **OK** to display the [Timer Record Edit] menu.

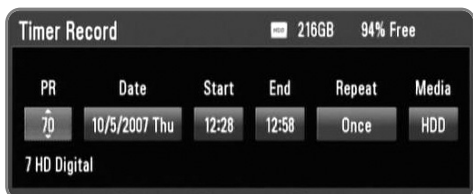

- 4 Follow the steps 3-5 from "Timer Recording (Manual)" on page 28 to complete the editing.

Instant Timer Recording

You can set the recording time instantly to stop the recording automatically.

- 1 Use **PR (+/-)** or **▲/▼** to select a programme you want to record.
- 2 Press **REC** to start recording.
- 3 While recording, press **REC** repeatedly to set the recording duration.
 - Continue (Normal recording) → 10M → 20M → 30M → 60M → 90M → 120M → Continue

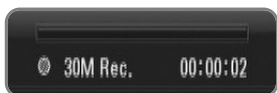

- 4 Press **STOP** to stop recording.



Media

You can play media files stored on various media. Select [Media] on [Home menu] and press [OK].



Select a menu option.



HDD

You can play media (MOVIE, MUSIC, PHOTO) files stored in the internal HDD or external HDD. (page 32-35)



USB

You can play media (MOVIE, MUSIC, PHOTO) files stored in USB device. Before using this function, you should connect USB device to the front panel recorder. (page 32-35)



PC

You can play media (MOVIE, MUSIC, PHOTO) files stored on PC connected via your local area network. (page 36)



Rec. List

You can play the recorded TV program. (page 32-35)



Playlist

Displays the Playlist you organized in this recorder. You need to organize your playlist before using it (page 34).



File Copy

You can copy media files by connecting to various storage devices and the network. (page 37)

Playback functions

The recorder can play movie, music and photo files on the HDD, USB, PC, REC.List, Playlist or using DLNA feature. Before playing movie, music or photo files, read "File requirement" on page 5.

Symbols used in playback functions

Each playback function has symbols which indicates available features as below

- MOVIE** Movie files in the HDD, USB or PC.
- MUSIC** Music files in the HDD, USB or PC.
- PHOTO** Photo files in the HDD, USB or PC.
- REC** Titles recorded via DTV tuner.
- DLNA-V** Movie files in the DLNA server.
- DLNA-M** Music files in the DLNA server.
- DLNA-P** Photo files in the DLNA server.
- Picasa** Photos from the Picasa web albums.

General playback

- 1 Press HOME.
- 2 Use ◀/▶ to select [Media] in the [Home] menu, and press OK.
- 3 Select a storage type using ◀/▶ and press OK.



- 1 Displays media (MOVIE, MUSIC, PHOTO) files stored in internal/external HDD .
- 2 Displays media (MOVIE, MUSIC, PHOTO) files stored in a connected USB device.
- 3 Displays media (MOVIE, MUSIC, PHOTO) files stored in your PC .
You need to input network ID and password. (page 36)
- 4 Displays Digital TV titles that recorded via DTV tuner.
To record DTV titles, see page 28-30.
- 5 Displays the Playlist you organized in this recorder. You need to organize your playlist before using it (page 34).

- 4 Use ◀/▶ to select a media type (MOVIE, MUSIC or PHOTO).



- 5 Use ▲/▼ to select a file you want to play.
 - Use ▲/▼ to select a folder, and press OK. A list of files and sub-folders in the folder appears.
 - If you want to move to the upper directory, press

- BACK or use ▲/▼ to select [] and press OK.
- Press INFO while selecting a movie file to display the detailed file information.

- 6 Press PLAY or OK to play the selected file.
 - Starts slideshow when selecting a photo file.
 - When playing a slideshow, press INFO to show the control icons as below.



Prev: Press ◀◀ to move to the previous file.

Next: Press ▶▶ to move to the next file.

90° [] []: Press ▲/▼ to rotate the picture clockwise or counterclockwise.

Stop: Press STOP (■) to stop the slideshow.

Hide: Press BACK to hide the control icons. To show the icons again, press INFO.



If you apply an effect, slideshow timing may be longer than you have set in [Slide Show timing] option. (page 35)

- 7 To pause playback, press PAUSE playing movie file.
 - Press PLAY to resume playback.
- 8 Press STOP to stop playback.

Sorting the recorded titles

REC

- 1 Press HOME.
- 2 Use ◀/▶ to select [Media] in the [Home] menu, and press OK.
- 3 Use ◀/▶ to select [Rec. List], and press OK.
- 4 Press green coloured button to bring up the options menu.
- 5 Use ▲/▼ to select a sorting method among [Latest], [Time] or [Title Name].

Latest	sorted by latest recording
Time	sorted by recorded time in numerical order.
Title Name	by title name in alphabetical order



- Press VOL +/- to adjust the sound level for audio output.

Frame-by-Frame playback

MOVIE DLNA-V REC

- 1 While a movie file is in playback, press PAUSE.
- 2 Press PAUSE repeatedly to play frame by frame.

Fast forward and fast reverse

MOVIE REC DLNA-V

- 1 While a movie file is in playback, press SCAN (◀◀/▶▶) to play fast forward or fast reverse.
- 2 Press SCAN (◀◀/▶▶) repeatedly to change the playback speed.
- 3 Press PLAY to return to normal playback speed.

Slow down the playing speed

MOVIE REC DLNA-V

- 1 While a movie file is in playback, press PAUSE.
- 2 press SCAN (▶▶) to play in slow motion.
- 3 Press SCAN (▶▶) repeatedly to change the playback speed.
- 4 Press PLAY to return to normal playback speed.

Skip to the next/previous file

MOVIE MUSIC PHOTO REC

DLNA-V DLNA-M DLNA-P Picasa

While a file is in playback, press SKIP (◀◀/▶▶).

- Movie file/Recorded title – Moves to the next file or beginning of the currently playing file. To move to the previous file, press SKIP (◀◀) twice.
- Music/Photo file – Moves to the previous or next file.

Resume playback

MOVIE REC DLNA-V

If you play a movie that was stopped previously, you can resume playback from the point where you pressed STOP.

- 1 Use ▲/▼ to select a file you want to resume.
- 2 Press PLAY or OK.
- 3 Use ◀/▶ to select [Yes], and press OK to resume playback.
 - If you select [No], the playback starts from the beginning.

Enlarges the playback image

MOVIE PHOTO REC DLNA-V

DLNA-P Picasa

- 1 While a movie or a photo file is in playback, press ZOOM.
 - If you press ZOOM while viewing a slideshow in photo list, the slideshow will be stopped.
 - If you try to do other function in movie playback, picture size return to normal size.
- 2 Press ZOOM repeatedly to change the magnification.
 - You can move through the zoomed picture using ▲/▼/◀/▶ buttons.
- 3 Press BACK to return to normal playback size.

Selecting a subtitle language

MOVIE REC DLNA-V

Some movie files or titles recorded may contains several subtitle languages. You can select a subtitle language when it is available.

- 1 While a movie file is in playback, press SUBTITLE.
- 2 Use ◀/▶ to select a subtitle language, and press OK.

Selecting a subtitle language code

MOVIE DLNA-V

If the movie subtitle is not displayed properly, change the subtitle language code that supports your language.

- 1 Press HOME.
- 2 Use ◀/▶ to select the [Setup], and press OK.
- 3 Use ◀/▶ to select the [Others] option.
- 4 Use ▲/▼ to select the [Code Page] and press OK.
- 5 Use ▲/▼ to select a language code that supports your language.



You can change the subtitle language code while a movie is in playback. Press and hold SUBTITLE for 3 seconds during playback. The language code will appear. Use ◀/▶ to select another language code until the subtitle is displayed properly and then press ENTER.

Selecting an audio language

MOVIE **DLNA-V** **REC**

Some movie files have several audio languages or encoding methods. You can select an audio language or an encoding method.





- 1 While a movie file is in playback, press AUDIO.
- 2 Use ◀/▶ to select an audio language or an encoding method, and press OK.

Repeat playback

MOVIE **MUSIC** **REC** **DLNA-V** **DLNA-M**

For movie and music playback, you can apply the various repeat modes.

- 1 While a movie or a music file is in playback, press REPEAT to select a repeat mode.
 - Press REPEAT repeatedly to select various repeat options as described below.

- | | |
|---|---|
|  | The current file will be played back repeatedly. |
|  | All files in the current directory will be played back repeatedly. |
|  | All files in the current directory will be played back repeatedly in random order. (music files only) |
|  | All files in the current directory will be played back in random order. (music files only) |

- 2 To cancel the repeat playback, press REPEAT repeatedly until repeat mode icon disappears.

Playback from selected time

MOVIE **REC** **DLNA-V**

- 1 While a movie file is in playback, press GOTO.
- 2 Use ◀/▶ to select a field from either hours, minutes and seconds.
- 3 Input the required start time using numerical buttons.
 - If you input wrong number, select the field and re-enter the correct number.
- 4 Press OK to start playback from the selected time.



This function may not be available on some movie files.

Add files to the Playlist

MOVIE **MUSIC** **PHOTO** **REC**

You can add your favorite movie, music and photo files to the playlist.

- 1 Follow the steps 1-5 from “General playback” on page 32 to select a file.
- 2 Press MARKER on the file.
 - You can mark multiple files using MARKER button.
- 3 Press EDIT to display option menu.
- 4 Use ▲/▼ to select [Add to playlist], and press OK to add to the playlist.
 - If you want to add multiple files to the playlist, press MARKER on each file, and select the [Add to the Playlist] on the option menu.
 - To unmark all marked files, select the [Unmark ALL] on the option menu.



Only the files on the internal HDD can be added to the playlist.

Delete a file/folder from the list

MOVIE **MUSIC** **PHOTO** **REC**

You can delete files/folders from HDD, USB, PC or Playlist.

- 1 Follow the steps 1-5 from “General playback” on page 32 to select a file.
- 2 Press EDIT to display option menu.
- 3 Use ▲/▼ to select [Delete], and press OK to delete file.
 - If you want to delete multiple files and/or folders from HDD, USB, PC or Playlist, press MARKER on each file or folder, and select the [Select Delete] on the option menu.
 - To unmark all marked files, select the [Unmark ALL] on the option menu.



- If you delete a file from the PC feature, the file on your computer will also be deleted.
- Although file from the playlist is deleted, the file on the original position will not be deleted.

Naming a file

MOVIE **MUSIC** **PHOTO** **REC**

You can rename the selected file on HDD, USB or PC.

- 1 Follow the steps 1-5 from “General playback” on page 32 to select a file.
- 2 Press EDIT to display option menu.
- 3 Use ▲/▼ to select [Rename], and press OK to display the virtual keyboard.
- 4 Use ▲/▼/◀/▶ to select a character, and press OK to confirm your selection.



- Select [Alphabet Capital], [Alphabet Small] or [Symbol], and press OK to change the character set of the virtual keyboard.
 - [Space]: Inserts a space at the cursor position.
 - [Delete]: Delete a previous character at the cursor position.
 - [← →]: Moves cursor to the left or right.
 - [OK]: Complete naming.
 - [Cancel]: Cancels the naming, and return to the previous.
- 5 Use ▲/▼/◀/▶ to select [OK] and press OK to complete a naming.



If you rename a file from the PC feature, the file name on your computer will also be changed.

Playing selected files

MOVIE **MUSIC** **PHOTO** **REC**

You can play only the selected files, using MARKER on the file list.

- 1 Follow the steps 1-5 from “General playback” on page 32 to select a file.
- 2 Press MARKER on the file.
 - You can mark multiple files using MARKER button.
- 3 Press EDIT to display option menu.
 - To unmark all marked files, select the [Unmark ALL] on the option menu.
- 4 Use ▲/▼ to select [Select play], and press OK to play selected files.

Selecting a slideshow speed

PHOTO **DLNA-P** **Picasa**

You can set the photo delaying timing while viewing a Slide Show.

- 1 Follow the steps 1-3 from “Selecting a subtitle language code” on page 33.
- 2 Use ▲/▼ to select the [Slide Show Timing] and press OK.
- 3 Use ▲/▼ to select a speed you want to set, and press OK.
 - If you select [Off], slideshow is not playable.

Selecting a slideshow effect

PHOTO **DLNA-P** **Picasa**

You can apply various transition style between pictures in a slideshow.

- 1 Follow the steps 1-3 from “Selecting a subtitle code” on page 33.
- 2 Use ▲/▼ to select the [Transition Effect] and press OK.
- 3 Use ▲/▼ to select an effect you want to apply on the slideshow, and press OK.

Listening to music while viewing a slideshow

PHOTO **DLNA-P**

You can listen to background music during slideshow.

- 1 Follow the steps 1-3 from “Selecting a subtitle language code” on page 33.
- 2 Use ▲/▼ to select the [Background Music] and press OK.
- 3 Use ▲/▼ to select [On], and press OK to take effect.
 - If you set this option to [Off], music file is not played when you start slideshow.



Music files and photo files must be located in the same directory for using this function.

Playing files on your PC

This recorder can access and play movie, music or photo files on a PC which is connected to your local area network.

Preparations:

- This recorder and your PC must be connected to the same local area network. (page 14-19)
- Note the Network User ID, password and workgroup of your PC
- Your PC must be turned on.
- The NetBios Protocol must be installed on your PC.
- Share folders or drivers on your PC.

Accessing to your PC

- 1 Press HOME.
- 2 Use ◀/▶ to select [Media], and press OK.



- 3 Use ◀/▶ to select [PC], and press OK.
- 4 Use ▲/▼ to select the workgroup that your PC is located, and press OK.
 - Press blue coloured button to search workgroup within your network environment.
 - If the connection of your PC is saved before, select [My_Shortcuts] and select connection previously saved.
- 5 Use ▲/▼ to select the name of your PC, and press OK.
 - Press blue coloured button to search for PCs again from the workgroup.
- 6 Use ▲/▼ to select the Network User ID and password of your PC, and press OK.



- 1 Input the Network User ID of your PC
- 2 Input the password that corresponds with your network ID.
- 3 Save a Network User ID and password in the [My_shortcuts] folder, so that the recorder can access your PC without entering network ID and password next time.

- 4 Complete the connection setting.
- 5 Cancels connecting to your PC.

- Refer to "Naming a file" on page 35 for using virtual keyboard.

- 7 Use ◀/▶ to select a media type (MOVIE, MUSIC or PHOTO).



- 8 Use ▲/▼ to select a file you want to play.
 - Press ▲/▼ to select a folder, and press OK. A list of files and folders in the folder appears.
 - If you want to move to the upper directory, press BACK or use ▲/▼ to select [] and press OK.
 - Press INFO while selecting a movie file to display the detailed file information.
- 9 Press PLAY or OK to play the selected file.
 - Refer to "Playback functions" on page 32-35 to use various playback functions.



Depending on your PC's environment, folders that you are not shared on your PC may be displayed on this recorder.

Editing the [My_Shortcuts]

Once a connection of your PC is saved in the [My_Shortcuts], you can browse the shares on your PC without entering network user ID and password. Additionally, you can edit your shortcut list as described below.

- 1 Follow the steps 1-3 from "Accessing to your PC" on page 36.
- 2 Use ▲/▼ to select the [My_Shortcuts], and press OK.
- 3 Press blue coloured button to display the editing options.
- 4 Use ▲/▼ to select an option, and press OK.

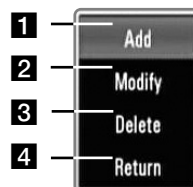

- 1 Adds a shortcut by manually inputting your PC's information.
- 2 Modifies the selected shortcut.
- 3 Deletes the selected shortcut.
- 4 Exits the editing options

Using [File Copy] features

You can move or copy files to the other storage or folder. You can delete files also.

Copying or moving files/folders

- 1 Press HOME.
- 2 Use ◀/▶ to select [Media], and press OK.
- 3 Use ◀/▶ to select [Copy], and press OK.



- 4 Use ▲/▼ to select a storage you want to copy or move file from, and press ▶.



- 5 Use ▲/▼ to select a storage you want to copy or move to, and press OK.
- 6 Use ▲/▼ to select file/folder you want to copy or move, and press MARKER.
 - Repeat this step to mark additional files and folders.
 - You need to input network ID and password for selecting files on PC.
- 7 Press ▶ to select the destination field.
- 8 Use ▲/▼ to select directory you want to copy or move to, and press REC.
 - You need to input network ID and password for selecting files on PC.
- 9 Use ◀/▶ to select [Copy] or [Move], and press OK.
 - Select [Cancel] to cancel copying or moving.



- If you try to copy or move a broken file, copy or move procedure will be stopped.
- If you copy or move a files/folders to a FAT16/FAT32 formatted storage, copy or move capacity is limited to 4GB.
- Do not turn off this recorder or other connected storage such as PC while files are copying or moving.
- If you have no writing permission, you can't copy file/folders to PC

Deleting files/folders

- 1 Press HOME.
- 2 Use ◀/▶ to select [Media], and press OK.
- 3 Use ◀/▶ to select [Copy], and press OK.
- 4 Use ▲/▼ to select a storage that contains files to delete, and press ▶.
- 5 Use ▲/▼ to select [Trash Can], and press OK.



- 6 Use ▲/▼ to select file/folder you want to delete, and press MARKER.
 - Repeat this step to mark additional files and folders.
 - You need to input network ID and password for selecting files on PC.
- 7 Press ▶.



- 8 Use ◀/▶ to select [OK], and press OK.
 - Select [Cancel] to cancel deleting.



To delete files on your PC, you must set the sharing privilege to be deleted on your PC.



DLNA

About DLNA

The DLNA features allow you to browse and play movies, music and photos stored on DLNA media servers connected on an identical Local Area Network (LAN) as the recorder.

This recorder allows playing files stored on a computer with Nero MediaHome 4 Essentials and a DLNA-compatible digital media server (PC and Consumer Electronics).



The Digital Living Network Alliance (DLNA) is a cross-industry organization of consumer electronics, computing industry and mobile device companies. Digital Living provides consumers with easy sharing of digital media through a wired or wireless network in the home.

The DLNA certification logo makes it easy to find products that comply with the DLNA Interoperability Guidelines. This unit complies with DLNA Interoperability Guidelines v1.5.

When a PC running DLNA server software or other DLNA compatible device is connected to this recorder, some setting changes of software or other devices may be required. Please refer to the operating instructions for the software or device for more information.

Notes on DLNA features

- Because the compatibility and available playback functions on the [DLNA] menu are tested on the bundle DLNA server (Nero MediaHome 4 Essentials) environment, file requirements and playback functions on the [DLNA] menu may differ depending on media servers.
 - The file requirements on page 5 are not always compatible. There may have some restrictions by file features and media server's ability.
 - If you press INFO while a movie file is selected, the file information is displayed on the screen. But, the information may not correct comparing the actual file features.
 - The thumbnail of the unplayable files can be displayed in the menu, but those cannot be played on this recorder.
 - If there is an unplayable music file in the [DLNA] menu, the recorder skip the file and play next file.
 - The file information indicated on the screen may not correct for music and movie files in [DLNA] menu.
- Playing a movie subtitle files are only available on media server created by supplied Nero MediaHome 4 Essentials software on this recorder's package.
 - The subtitle file name and movie file name have to be the same and located at the same folder.
 - If subtitle files have been added after a directory has been indexed already, the user has to remove and re-add the folder to the list of shares.
 - The playback and operating quality of the [DLNA] function may affected by your home network condition.
 - The files from removable media such as USB drive, DVD-drive etc. on your media server may not be shared properly.

Installing Nero MediaHome 4 Essentials

Nero MediaHome 4 Essentials is a software for sharing movie, music and photo files stored on your computer to this recorder.



- The supplied Nero MediaHome 4 Essentials CD-ROM is a customized software edition only for sharing files and folders to this recorder.
- The supplied Nero MediaHome 4 Essentials software does not support following functions: Transcoding, Remote UI, TV control, Internet services and Apple iTunes
- This manual explains operations with the English version of Nero MediaHome 4 Essentials as examples. Follow the explanation referring to the actual operations of your language version.

Before you install Nero MediaHome 4 Essentials, check the system requirement shown below.

- Windows® XP (Service Pack 2 or higher), Windows Vista® (no Service Pack required), Windows® XP Media Center Edition 2005 (Service Pack 2 or higher), Windows Server® 2003
- Windows Vista® 64-bit edition (application runs in 32-bit mode)
- Hard drive space: 200 MB hard drive space for a typical installation of Nero MediaHome stand-alone
- 1.2 GHz Intel® Pentium® III or AMD Sempron™ 2200+ processors
- Memory: 256 MB RAM
- Graphics card with at least 32 MB video memory, minimum resolution of 800 x 600 pixels, and 16-bit color settings
- Windows® Internet Explorer® 6.0 or higher
- DirectX® 9.0c revision 30 (August 2006) or higher
- Network environment: 100 Mb Ethernet, WLAN (IEEE 802.11b/g/n)

Start up your computer, and insert the Nero MediaHome 4 Essentials CD-ROM into your computer's CD-ROM drive. An installation wizard will walk you through the quick and uncomplicated installation process.

To install Nero MediaHome 4 Essentials, proceed as follows:

- 1** Close all Microsoft Windows programs and exit any anti-virus software that may be running.
- 2** Insert the Nero MediaHome 4 Essentials CD-ROM into your computer's CD-ROM drive.
- 3** Click [Nero MediaHome 4 Essentials]. The installation is prepared and the installation wizard appears.
- 4** Click the [Next] button to display the serial number input screen.
Click [Next] to go to the next step.

5 If you accept all conditions, click [I accept the License Conditions] check box and click [Next]. Installation is not possible without this agreement.

6 Click [Typical] and click [Next].

The installation process is started.

7 If you want to take part in the anonymous collection of data, select the check box and click the [Next] button.

8 Click the [Exit] button to complete the installation.

Sharing files and folders

On your computer, you must share the folder containing movie, music and/or photo content to play them using [DLNA] features.

This parts explains the procedure for selecting the shared folders on your computer.

1 Double-click the "Nero MediaHome 4 Essentials" icon on the desktop.

2 Click [Network] icon on the left and define your network name in the [Network name] field. The Network name you enter will be recognized by your recorder.

3 Click [Shares] icon on the left.

4 Click [Local Folders] tab on the [Shared] screen.

5 Click [Add] icon to open the [Browse Folder] window.

6 Select the folder containing the files you want to share. The selected folder is added to the list of shared folders.

7 Click [Start Server] icon to start the server.



- If the shared folders or files are not displayed on the recorder, click the folder on the [Local Folders] tab and click [Rescan Folder] at the [More] button.
- Visit www.nero.com for more information and software tools.

Operating DLNA feature

The recorder can play movie, music and photo files on the DLNA server.

Before playing movie, music or photo files from DLNA server, read "File requirement" on page 5.

Preparations:

- This recorder and DLNA server must be connected to the same local area network. (page 14-19)
- DLNA server device must be turned on.
- Depending on DLNA server, you may need permission to get access .

General operation

1 Press HOME.

2 Use ◀/▶ to select [DLNA], and press OK.



3 Use ▲/▼ to select a server, and press OK.

- Press blue coloured button to search servers within your network environment.



4 Use ◀/▶ to select a media type (MOVIE, MUSIC or PHOTO).



5 Use ▲/▼ to select a file you want to play.

- Press ▲/▼ to select a folder, and press OK. A list of files and folders in the folder appears.
- If you want to move to the upper directory, press BACK or use ▲/▼ to select .. and press OK.
- Press INFO while selecting a movie file to display the detailed file information.

6 Press PLAY or OK to play the selected file.

- Refer to "Playback functions" on page 32-35 to use various playback functions.
- Starts slideshow when selecting a photo file.
- When playing a slideshow, press INFO to show the control icons as below.



Prev: Press ◀◀ to move to the previous file.

Next: Press ▶▶ to move to the next file.

90° ↻: Press ▲/▼ to rotate the picture clockwise or counterclockwise.

Stop: Press STOP (■) to stops the slideshow.

Hide: Press BACK to hide the control icons. To show the icons again, press INFO.



YouTube

Operating YouTube feature

You can search and play YouTube videos on this recorder.

Preparations:

- A broadband Internet service is required to use this feature.
- Network settings must be set before using this features.

General operation

- 1 Press HOME.
- 2 Use ◀/▶ to select [YouTube], and press OK.



- 3 Use ▲/▼ to select an option from the main menu, and press ENTER.

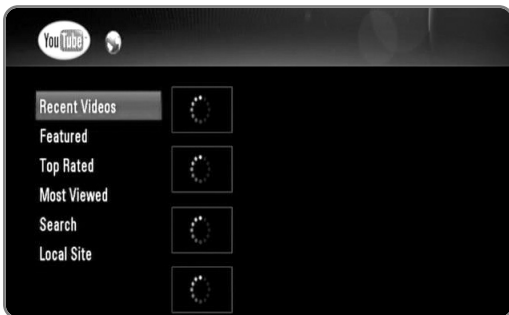

Recent Videos : The most recently updated videos list will be displayed.

Featured : The featured videos list will be displayed.

Top Rated : The best rated videos list from YouTube server will be displayed. The period option appears on the left of the screen.

Most Viewed : The most viewed videos list will be displayed. The period option appears on the left of the screen.

Search : The keyboard menu will be displayed. See "Searching videos" on page 42 for more detail.

Local Site : Choose which country's videos you would like to view. The countries listed on the [Local Site] menu may differ from those listed on the YouTube web site.

- 4 Use ▲/▼ to select a video from list, and press OK to play the video.

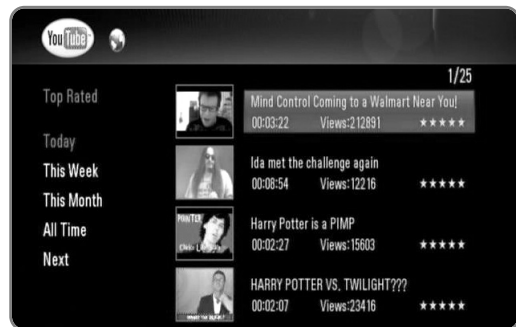

- If you select [Most Viewed] or [Top Rated] option, the period option appears on the screen. Use ▲/▼/◀/▶ to select a period option and press OK to display the videos within the selected period.
- Press BACK to return to the main YouTube menu screen.
- Use ▲/▼/◀/▶ to select [Next] or [Prev] to move to the next or previous video list.

- 5 Use ▲/▼ to select a video from list, and press OK to play the video.
 - Press PAUSE to pause playback, and press PLAY to resume playback.
 - Press OK to view the video in full screen.



Full Screen : Enlarges the video screen in full screen.

Related Video : Displays the related videos.

Previous : Moves to the previous menu screen.

6 Press STOP to stop playback.



- The settings of this recorder do not affect the YouTube's playback quality.
- The playback of YouTube videos may be paused, stopped or buffering occurring often depending on your broadband speed.
We recommend a minimum connection speed of 1.5 Mbps. For the best playback condition, a connection speed of 4.0 Mbps is required. Sometimes your broadband speed varies based on your ISP's network conditions. Contact your ISP if you have problems maintaining a fast connection that is reliable, or if you want to increase your connection speed. Many ISPs offer a variety of broadband speed options.

Searching YouTube videos

You can search videos by entering search words up to 41 characters.

- 1** Use ▲/▼ to select [Search] option on the YouTube main screen, and press OK.
- 2** Enter a search word. Use ▲/▼/◀/▶ to select a character, and press OK to confirm your selection.



- Select [Alphabet Capital], [Alphabet Small] or [Symbol], and press OK to change the character set of the virtual keyboard.
 - [Space]: Inserts a space at the cursor position.
 - [Delete]: Delete a previous character at the cursor position.
 - [← →]: Moves cursor to the left or right.
 - [OK]: Complete naming.
 - [Cancel]: Cancels the naming, and return to the previous.
- 3** Use ▲/▼/◀/▶ to select [OK] and press OK to display videos according to the search word.
 - Use ▲/▼/◀/▶ to select [Next] or [Prev] to move to the next or previous video list.

Selecting your local site

You can select a country in which you want to view YouTube videos. The countries listed on the [Local Site] menu may differ with those listed on the YouTube web site.

- 1** Use ▲/▼ to select [Local Site] option on the YouTube main screen,, and press OK.

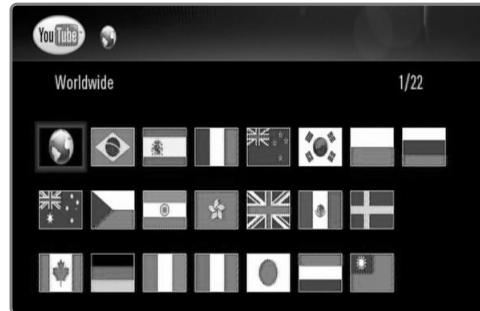

- 2** Use ▲/▼/◀/▶ to select a country, and press OK.



Picasa

Operating Picasa web albums feature

You can view and download photos from the Picasa web albums. Only public photos can be viewed and downloaded. If you have your own album on the Picasa web albums., you can browse your photos using this recorder.

General operation

1 Press HOME.

2 Use ◀/▶ to select [Picasa], and press OK.



3 Use ▲/▼ to select an option from the main menu, and press ENTER.



Search for Photo : The keyboard menu will be displayed. See “Searching Picasa web albums” on page 44 for more detail.

New ID : The keyboard menu will be displayed. See “Viewing your Picasa web albums” on page 44 for more detail.

Remove ID : Delete the selected ID from the ID list.

4 Use ▲/▼/◀/▶ to select a photo, and press OK to start slideshow.



- If you want to download a photo, use ▲/▼/◀/▶ to select a photo and press blue coloured button. Downloaded photo will be stored in the [image] folder on the internal HDD.

5 Press INFO (i) to show the control icons as below.



Prev: Press ◀◀ to move to the previous file.

Next: Press ▶▶ to move to the next file.

90° ◻◻: Press ▲/▼ to rotate the picture clockwise or counterclockwise.

Stop: Press STOP (■) to stop the slideshow.

Hide: Press BACK to hide the control icons. To show the icons again, press INFO.

6 Refer to “Playback functions” on page 32-35 to use various playback functions.



The playback of Picasa photos may not be fluent depending on your broadband speed.

We recommend a minimum connection speed of 1.5 Mbps. For the best playback condition, a connection speed of 4.0 Mbps is required. Sometimes your broadband speed varies based on your ISP’s network conditions. Contact your ISP if you have problems maintaining a fast connection that is reliable, or if you want to increase your connection speed. Many ISPs offer a variety of broadband speed options.

Searching Picasa web albums

You can search photos by entering search words up to 43 characters.

- 1 Use ▲/▼ to select [Search for photos] option on the Picasa web albums main screen, and press OK.
- 2 Enter a search word. Use ▲/▼/◀/▶ to select a character, and press OK to confirm your selection.



- Select [Alphabet Capital], [Alphabet Small] or [Symbol], and press OK to change the character set of the virtual keyboard.
 - [Space]: Inserts a space at the cursor position.
 - [Delete]: Delete a previous character at the cursor position.
 - [← →]: Moves cursor to the left or right.
 - [OK]: Complete naming.
 - [Cancel]: Cancels the naming, and return to the previous.
- 3 Use ▲/▼/◀/▶ to select [OK] and press OK to display photos according to the search word.
 - Use ▲/▼/◀/▶ to select [Next] or [Prev] to move to the next or previous photo list.

Viewing your Picasa web albums

If you have your own web album on the Picasa web albums, you can view your own album by entering your ID.

Only public albums can be shown on this recorder.

- 1 Use ▲/▼ to select [New ID] option on the YouTube main screen, and press OK.
- 2 Refer to the steps 3 from “Searching Picasa web albums” on page 44 to enter your Google ID.
- 3 Use ▲/▼/◀/▶ to select [OK] and press OK to add your ID on the ID List.



- 4 Use ▲/▼/◀/▶ to select your ID, and press OK to display your photo album.
 - Only the public photos can be displayed using this recorder.
- 5 Use ▲/▼/◀/▶ to select a photo, and press OK to start slideshow.



If you want to edit your album, you must visit your Picasa web albums. Refer to the help page of the Picasa web albums.

Removing an ID from the ID List

You can remove an ID from the ID List

- 1 Use ▲/▼/◀/▶ to select an ID on the YouTube main screen, you want to delete from the ID List.
- 2 Use ▲/▼ to select [Remove ID] option, and press OK.



Setup

General Setup Operation

- 1 Press HOME.
- 2 Use ◀/▶ to select [Setup] in the [Home] menu, and press OK.



- 3 Use ◀/▶ to select an option from the [Setup] menu, and press OK.



- 4 Use ▲/▼ to select a desired option, and press OK to display the sub-options .

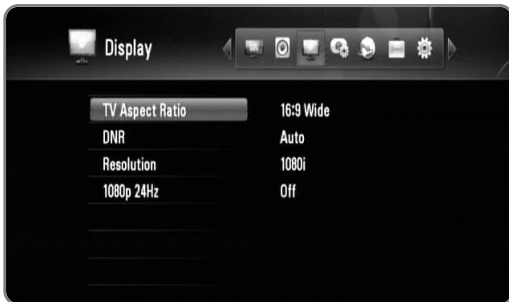

- 5 Use ▲/▼ to select a desired option, and press OK to set an option.



DTV settings



Region

Select a region where you operate this recorder.
Refer to page 22 for more information.

Auto Programming

This option scans a programme and sets the available programmes. Refer to page 22 for more information.

Program Edit

This option allows you to edit the TV or Radio programmes. Refer to page 23 for more information.

Parental Guidance

You can set the limitation of TV viewing according to the age limit you set. Your password is required to watch a locked program.

Refer to page 23-24 for more information.



Refer to the table below for the rating levels .

Rating Level	Age
P	5-6
C	7-8
G	9-10
PG	11-12
M	13-14
MA	15-16
AV	17
R	18

Antenna Feed 5V

If you are using an indoor antenna, use one with a signal amplifier rated at DC 5V, 100mA and set this option to [On].
Refer to page 24 for more information.

Audio settings



DRC

This option allows you to listen to a movie at a lower volume without losing clarity of sound.

Set [DRC] to [On] for the Dolby Digital encoded files only and [Comfort] for files with any encoding method.

Digital Output

Selects the type of digital audio signal when using the HDMI OUT or DIGITAL AUDIO OUT (OPTICAL or COAXIAL) jack.

[HDMI PCM]: Select if you connect this recorder's HDMI OUT jack to a device with two-channel digital stereo decoder.

[HDMI Bitstream]: Select if you connect this recorder's HDMI OUT jack to a device with LPCM, Dolby Digital and DTS decoder.

[SPDIF PCM]: Select if you connect this recorder's DIGITAL AUDIO OUT jack to a device with two-channel digital stereo decoder.

[SPDIF Bitstream]: Select if you connect this recorder's DIGITAL AUDIO OUT jack to a device with LPCM, Dolby Digital and DTS decoder.

Sampling Freq.

[48KHz]: Select this if your A/V Receiver or Amplifier is NOT capable of handling 192 KHz and 96 KHz signal. When this choice is made, this unit automatically converts any 192 KHz and 96 KHz signals to 48 KHz so your system can decode them.

[96KHz]: Select this if your A/V Receiver or Amplifier is NOT capable of handling 192 KHz signals. When this choice is made, this unit automatically converts any 192 KHz signals to 96 KHz so your system can decode them.

[192KHz]: Select this if your A/V Receiver or Amplifier is capable of handling 192 KHz signals.

- If audio signal is outputted through HDMI OUT jack and the resolution is set to lower than 720p, the sampling frequency can be limited to 48 KHz.

Check the documentation for your A/V Receiver or Amplifier to verify its capabilities.

Display settings



TV Aspect Ratio

Selects the aspect ratio of the connected TV.

[Letter Box 4:3]: Select this when connecting to a standard 4:3 screen TV and prefer the wide picture with bands on the upper and lower portions of the screen.

[Pan Scan 4:3]: Select this when connecting to a standard 4:3 screen TV and prefer the wide picture on the entire screen and cuts off the portions that do not fit.

[16:9 Original]: Select when a 16:9 wide TV is connected. The 4:3 picture is displayed with an original 4:3 aspect ratio, with black bars appearing at the left and right sides.

[16:9 Wide]: Select when a 16:9 wide TV is connected. The 4:3 picture is adjusted horizontally (in a linear proportion) to fill the entire screen.

DNR

(Digital Noise Reduction)

Set this option to [Auto] to reduce the digital noise, which may appear especially on fast-moving pictures, produced in the MPEG compression process.

Resolution

Sets the output resolution of the Component and HDMI video signal. Refer to "Resolution Setting" for details about the resolution.

[Auto] – If the HDMI OUT jack is connected for TVs providing display information (EDID), automatically selects the resolution best suited to the connected TV. If the COMPONENT VIDEO OUT is only connected, this changes the resolution to 1080i as default resolution.

[1080p]: Outputs 1080 lines of progressive video.

[1080i]: Outputs 1080 lines of interlaced video.

[720p]: Outputs 720 lines of progressive video.

[576p]: Outputs 576 lines progressive video.

[576i]: Outputs 576 lines of interlaced video

1080p 24Hz

When the resolution is set to 1080i or 1080p, change this option to [On] for smooth presentation of film material (24Hz) with a HDMI-equipped display compatible with 1080/24p input.



- When you select [ON], you may experience some picture disturbance when the video switches video and film material.
- When the 1080p 24Hz video source is outputted via HDMI connection, the COMPONENT VIDEO OUT may not visible any video signal.

Record settings

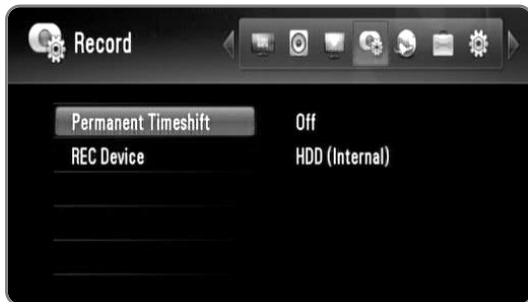

Permanent Timeshift

Set this option to [On] to use the Time Shift function automatically without pressing TIMESHIFT button. The timeshift will start after TV viewing is started. Refer to page 24 for more information.

REC Device

This option sets the storage where your TV recording will be stored. Select an option between [HDD (Internal)], [HDD (External)] or [USB], and press OK to set. Refer to page 24 for more information.



When you select [USB], make sure that there is sufficient space for the recording on the USB device.

Network settings



Wired LAN Setup

If you have connected this recorder to a local area network (LAN) using LAN cable, the recorder needs to be set up for network communication. (See "Wired network connection" on pages 14-15.)

Wireless Setup

If you have connected the Wireless LAN adapter on this recorder, the recorder needs to be set up for wireless network communication. (See "Wireless network connection" on pages 16-19.)

Software Update

Your recorder is able to keep the built-in digital tuner up to date with the latest software. You can either check for updates manually, or set the recorder to do it automatically at regular interval.

While the recorder is updating, there may be a disruption in reception for a few hours. The reception should return to normal after the update is complete.

This recorder must be plugged into AC power to receive updates.

Do not unplug your recorder while an update is in progress.

The update is not available during recording, Timeshift, viewing teletext or EPG menu.

[Standby mode]: Updates the software when this recorder is turned off. The check mark appears when this option is selected.

[Operation Mode]: Start the software update immediately.

Refer to page 49 for more information.

Network Update

You can update the software by connecting the recorder directly to the software update server via wired or wireless network connection to the Internet.

Refer to page 49 for more information.

System Info

Shows system information. (MODEL, CHIP ID or MAIN VER)

Disclaimer Notice

Press ENTER or ► to view the notice of Network Service Disclaimer on page 58.

System settings

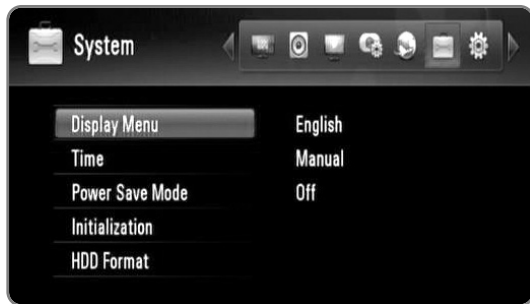

Display Menu

Select a language for the Setup menu and information display.

Time

The clock must be set in order to use timer recording.

[Auto]: Set the programme that broadcasts a clock signal and the clock will be set automatically.

If the time that has been automatically set is not correct when compared your local time, you can set additional time option. Select your region in the [Time Zone] option to set a time relative to area. If the summer time has started in your region, select the [Time Offset] option and increase or decrease time using ◀/▶, and press OK.

[Manual]: If there is no channel that broadcasts a clock signal in your area, you can set the time and date manually. Use ◀/▶ to select each field, and input correct time and date using ▲/▼, and press OK.

Power Save Mode

Selects whether this recorder is in power save mode when the power is turned off. This option is not available when a timer recording is set.

[ON]: The front panel display is off and only signals arriving at the antenna input are passed through when the recorder is turned off.

[OFF]: Turns off the [Power Save Mode] function.

Initialization

You can reset the recorder to its original factory settings.

[Cancel]: Return to the previous.

[Factory Set]: You can reset the recorder to all its factory settings. Some options cannot be reset (Rating and Password). The [Setup Wizard] menu appears on the screen after the factory settings.

HDD Format

Everything recorded on the HDD will be erased. Select an storage option between [HDD (Internal)] and [HDD (External)], and press OK to perform the formatting.

Others settings

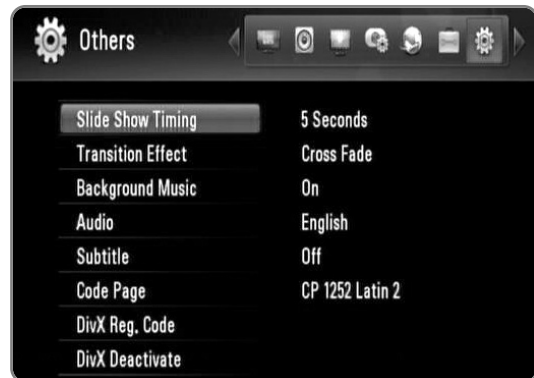

Slide Show Timing

You can set the photo delaying timing while viewing a Slide Show. (See “Selecting slideshow speed” on pages 35.)

Transition Effect

Specify the transition style between pictures in a slideshow. (See “Selecting a slideshow effect” on pages 35.)

Background Music

This option is available after the background music is selected using [On]. This option is not available on [Off] (See “Listening to music while viewing a slideshow” on pages 35.)

Audio / Subtitle

Select a default language for the DTV Audio/Subtitle.

Code Page

If a movie subtitle does not display properly, change the recorder’s subtitle language code. (See “Selecting a subtitle language code” on pages 33.)

DivX Reg. Code

ABOUT DIVX VIDEO: DivX® is a digital video format created by DivX, Inc. This is an official DivX Certified device that plays DivX video. Visit www.divx.com for more information and software tools to convert your files into DivX videos.

ABOUT DIVX VIDEO-ON-DEMAND: This DivX® Certified device must be registered in order to play DivX Video-on-Demand (VOD) content. To generate the registration code, locate the [DivX Reg. Code] section in the [Setup] menu. Go to vod.divx.com with this code to complete the registration process and learn more about DivX VOD.



All the downloaded videos from DivX® VOD can only be played back on this recorder.

DivX Deactivate

Deactivate your recorder and display the deactivation code. Go to vod.divx.com for more information.

Reference

Software update via the Internet

You can update the latest software to enhance the products operation and/or add new features using broadband Internet connection.

Preparations:

- A broadband Internet service is required to use this feature.
- Network settings must be set before using this features.
- Stop recording before using update function.

- 1 Press HOME.
- 2 Use ◀/▶ to select [Setup] in the [Home] menu, and press OK.
- 3 Use ◀/▶ to select the [Network] option from the [Setup] menu, and press OK.
- 4 Use ▲/▼ to select the [Network Update], and press OK to display the sub-options.
- 5 Press OK to start network update.
 - The recorder will check for the newest update.
 - If there is no update available, the Message, "No update is found." appears.
- 6 Use ◀/▶ to select the [Yes], and press OK to start software download.
 - When downloading is completed, the message, "Download is complete. Do you want to update?" appears.
- 7 Use ◀/▶ to select the [Yes], and press OK to start software update.
- 8 When update is completed, the message, "Update is complete." will appear, and the power will turn off automatically after 5 seconds.
- 9 Turn the power back on. The system now operates with the new version.

Software update via built-in tuner

You can also update the latest software through the built-in digital tuner.

Preparations:

- DTV antenna must be connected to the ANTENNA IN jack on the rear panel.
- Stop recording before using update function.

- 1 Press HOME.
- 2 Use ◀/▶ to select [Setup] in the [Home] menu, and press OK.
- 3 Use ◀/▶ to select the [Network] option from the

[Setup] menu, and press OK.

- 4 Use ▲/▼ to select the [Software Update], and press OK to display the sub-options.
- 5 Use ▲/▼ to select the [Operation mode], and press OK.
- 6 Use ◀/▶ to select the [Yes], and press OK to search for a new update.
 - The recorder will check for the newest update.
 - If there is no update available, the Message, "No software." appears.
- 7 Use ◀/▶ to select the [Yes], and press OK to start software update.
- 8 When update is completed, the message, "Update is complete." will appear, and the power will turn off automatically after 5 seconds.
- 9 Turn the power back on. The system now operates with the new version.

Formatting HDD

- 1 Press HOME.
- 2 Use ◀/▶ to select [Setup] in the [Home] menu, and press OK.
- 3 Use ◀/▶ to select the [System] option from the [Setup] menu, and press OK.
- 4 Use ▲/▼ to select the [HDD Format], and press OK to display the sub-options.
- 5 Use ▲/▼ to select a storage between [HDD (Internal)] and [HDD (External)] and press OK.
 - Select [Cancel] and press OK to cancel.
 - Warning message appears on the screen.
- 6 Use ◀/▶ to select the [OK], and press OK.
- 7 Use ▲/▼ to adjust the buffer for timeshift function, and press OK while [Next] option is highlighted.
 - This option is available only when you are formatting the internal HDD.
 - Select [Back] and press OK to return to the previous.
- 8 Use ◀/▶ to select the [Format], and press OK to start the HDD format.
 - Select [Back] and press OK to return to the previous.
- 9 After HDD format is finished, press OK to reboot the recorder.

External HDD Installation

You can install an additional HDD to the external HDD slot.

Preparations:

- Prepare a 3.5" SATA HDD.
- It is strongly recommended to use SATA standard HDD of makers for the external HDD. (Seagate, Western Digital, Hitachi, Samsung)
- The recorder must be turned off before installation.

- 1 Press PUSH/OPEN on the front of the recorder.

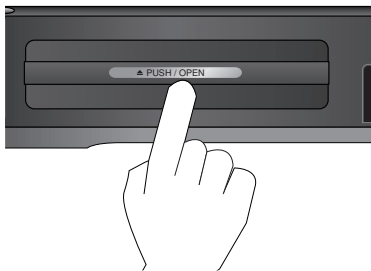

- 2 Grab the holder and extract it completely to the arrow direction.

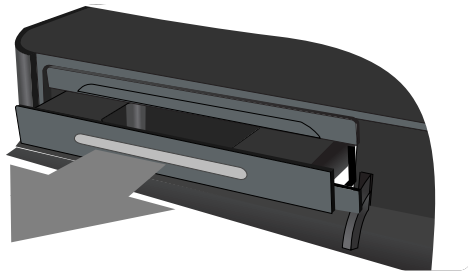

- 3 Stretch out the Right/Left hooks as shown below. Match the hooks with External case. Push and fit the HDD into the place completely.

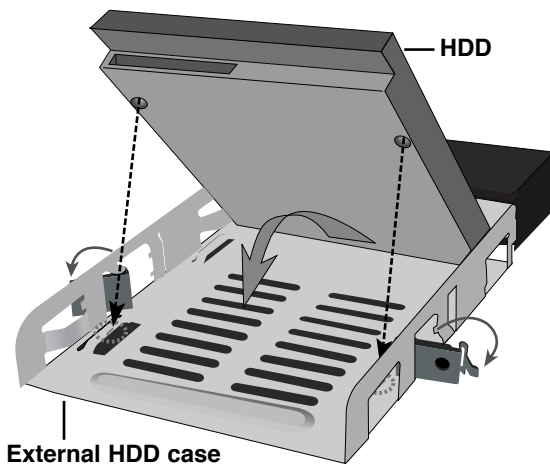

- 4 Fasten the hooks as shown below.

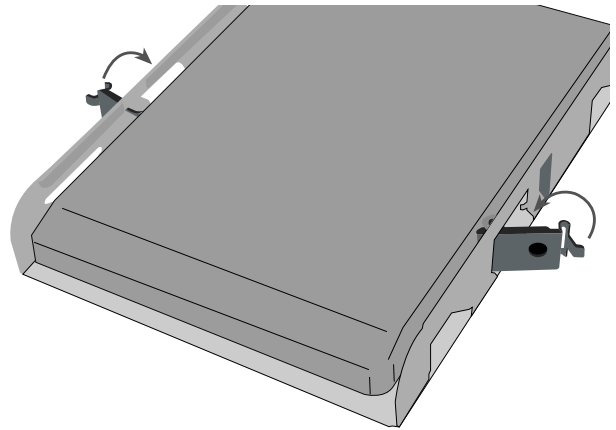

- 5 Insert the external HDD to the recorder as shown below and push it to fit into the recorder completely.

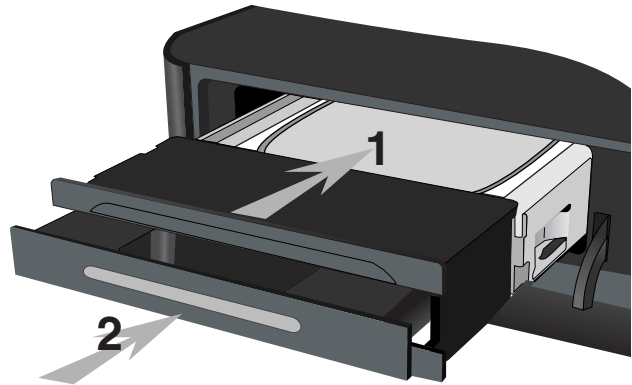

If you want to completely fix the external HDD, fix the screws as below.

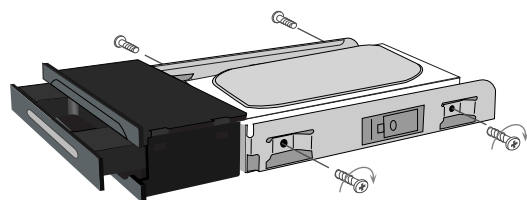

About the internal/External HDD

The internal hard disk drive (HDD) is a fragile piece of equipment. Please use the recorder following the guidelines below to protect against possible HDD failure.

- Do not move the recorder while it is on.
- Do not use a damaged HDD. Product can be damaged.
- Install and use the recorder on a stable, level surface.
- Do not use the recorder in excessively hot or humid places, or in places that may be subject to sudden changes in temperature. Sudden changes in temperature can cause condensation to form inside the recorder. This can be a cause of HDD failure.
- While the recorder is switched on, do not unplug from the wall socket or switch the electricity off from the breaker switch.
- Do not move the recorder immediately after switching it off. If you need to move the recorder, please follow the steps below:
 1. After the message "OFF" is shown in the display, wait at least two minutes.
 2. Unplug from the wall socket.
 3. Move the recorder.
- If there's a power failure while the recorder is on, there is a chance that some data on the HDD will be lost.
- The HDD is very delicate. If used improperly or in an unsuitable environment, it is possible that the HDD will fail after a few years of use. Signs of problems include playback unexpectedly freezing and noticeable block noise (mosaic) in the picture. However, sometimes there will be no warning signs of HDD failure.
- If the HDD fails, playback of recorded material will not be possible. In this case it will be necessary to replace the HDD.
- The manufacturer disclaims responsibility for loss of data contained in internal/external HDD.
- When detaching a HDD from the external HDD case, the HDD can be extremely hot and you may get injury from it. Proper cooling is required before detaching a HDD from external HDD case.
- It is strongly recommended to use SATA standard HDD of makers as below for the external HDD. (Seagate, Western Digital, Hitachi, Samsung)
- While operating this recorder, do not detach external HDD. It may cause a serious defect to this recorder.
- Maximum capacity of external HDD is limited to 1TB.
- The HDD capacity displayed on your TV screen may not exactly same with the capacity printed on your HDD.

Connecting an USB Device

This recorder can play the MOVIE / MUSIC / PHOTO files contained in the USB Device connected on the front panel.

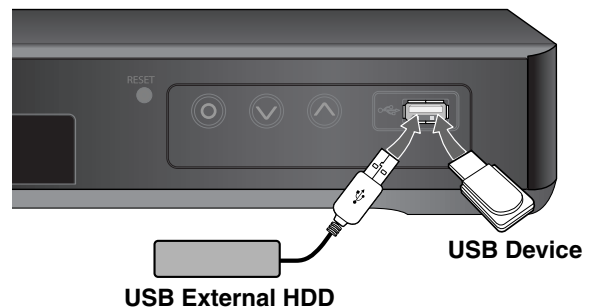

Inserting the USB Device

Insert straight-in until it fits into place.

Removing the USB Device

Withdraw the USB Device carefully when the connected USB Device is not operating.



- This recorder supports only USB Flash Drive and USB External HDD with FAT16, FAT32 or NTFS format.
- It is recommended to use the USB device with one partition.
- Do not extract the USB device during operation (play, etc.).
- An USB device which requires additional program installation when you have connected it to a computer is not supported.
- This recorder supports USB devices with USB1.1 and USB2.0.
- Movie Files, Music files and photo files can be played. For details of operations on each file, refer to relevant pages.
- Regular back up is recommended to prevent data loss.
- If you use a USB extension cable or USB HUB, the USB devices may not be recognized.
- Some USB device may not work on this recorder.
- Digital cameras and mobile phones are not supported.
- USB Port of the recorder cannot be connected directly to your PC. The recorder cannot be used as a storage device.
- Unformatted storage must be used after formatting.
- If you use a USB extension cable or USB HUB, the USB devices may not be recognized.
- If USB HDD can't be recognized, try another different USB cable.
- Some of USB cable may not support enough current for normal USB operation.

Controlling a TV with the Supplied Universal Remote Control

You can control the volume, input source, and power state of your TV with the supplied Universal Remote Control. If your TV is listed in the table on pages 53-54, set the appropriate manufacturer code. Follow steps 1-2 as shown right. You can control your TV using the buttons below.

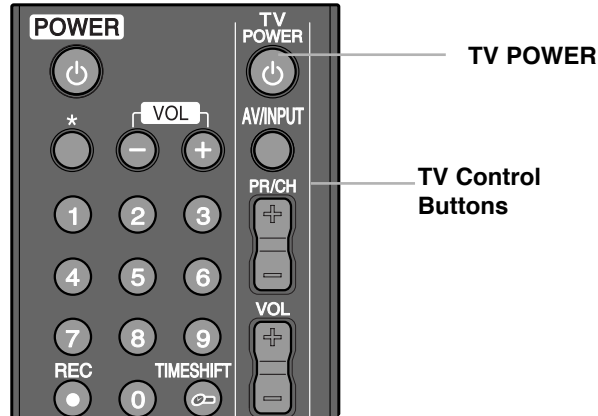

By pressing	You can
TV POWER	Turn the TV on or off.
AV/INPUT	Switch the TV's input source between the TV and other input sources.
PR/CH +/-	Scan up or down through memorized programmes.
VOL +/-	Adjust the volume of the TV.



Depending on the TV being connected, you may not be able to control your TV using some of the buttons.

To programme the remote to control the TV using the manufacturer code

If your TV is listed in the table on the next page, set the appropriate manufacturer code.

- 1 While holding down TV POWER button, press the number buttons to select the manufacturer code for your TV (Refer to table on the next page).
 - If more than one code number is listed, try entering them one at a time until you find the one that works with your TV.
- 2 Release TV POWER button.



- Depending on your TV, some or all buttons may not function on the TV, even after entering the correct manufacturer code.
- If you enter a new code number, the code number previously entered will be erased.
- When you replace the batteries in the remote, the code number you have set may be reset to the default setting. Set the appropriate code number again.

Code numbers of controllable TVs

If more than one code number is listed, try entering them one at a time until you find the one that works with your TV.

BRANDS	CODES
ADMIRAL	137 204
ADYSON	159 219
AKAI	009 010 108 132 133 135 139 140 156 174 175
AKURA	064 086 108 110 155 171
ALBA	009 060 064
ALLSTAR	108
AMSTRAD	006 025 157
AMWAY	108
ANITECH	010 049 108 185 219
ANTECNO	064
ARC EN CIEL	173 179 239
ASA	087 102 108 235 236
ASBERG	185
ASORA	171
ATLANTIC	089 197
AUDIOSONIC	085
AUTOVOX	159 163 197
BANK	232
BEKO	045 085 086 108 250
BESTAR	086
BLAUPUNKT	031 091 092 096 097 098 099 210 253
BONDSTEC	163
BOSCH	210
BRANDT	173 179 225 239
ELECTRONIQUE	
BRIONVEGA	204
BSR	144
BUSH	009 136 139 144 232
CENTURY	165 204
CGE	139 165 210
CIE	025 108 170
CLATRONIC	009 010 064 108 144 149 159 164 165 171 185
CLARIVOX	033
CONDOR	108 149 191
CONIC	219
CONTEC	171 222
CONTINENTAL	173 179 225 239
EDISON	
COSMOS	108
CROSLEY	165 204
CROWN	084 085 086 108 144 171 185
CS-ELECTRONICS	064
DAEWOO	051 108 120 127 170
DANSAI	010 219
DE GRAAF	108 134
DECCA	070 108 159 161 162 184 189 190 206
DECCAVIDEO	108
DUAL	233
DUMONT	204
ELBE	058 144 157 160 192 246
ELBIT	108 248
ELECTROVENDA	108
ELEKTRONIKA	108
ELIN	108

BRANDS	CODES
ELITE	064 149
ELMAN	144
ELTA	010 171
EMERSON	108 204
ESC	108
ETRON	133
EUROPHON	144 159
EXPERT	089
FENNER	171
FERGUSON	078 079 080 160 182 195 198 199 200 201 202
FINLANDIA	194 195
FINLUX	008 087 102 104 105 107 108 140 144 159 161 174 189 235 236
FIRST-LINE	144
FISHER	086 208 222 233
FORMENTI	108 149
FRABA	108
FRONTECH	136 171 220
FUBA	073 109
FUJITSU GENERAL	088 159 197
FUNAI	010
GALAXIS	108 185
GALERIA	171
GBC	137 144 171
GEC	011 108 129 147 159 189
GELOSO	064 137 144 164 171
GENERAL	171
GENERAL TECHNIC	171
GOLDHAND	159 171
GOLDSTAR	038 050 108 110 136 144 159 163 166 171 191 219 237
GOODMANS	009 064 108 109 110 120 159 170 171
GORENJE	086
GPM	010 064
GRANADA	027 105 108 111 121 134 140 159 162 167 187 194 195 238
GRUNDIG	091 092 093 094 095 097 098 100 101 172 232 238
HCM	010 108 159 171
HIFIVOX	173 179 239
HINARI	010 064 108 133 171
HIT	204
HITACHI	011 013 015 017 021 022 023 024 028 029 030 035 039 040 041 048 053 054 055 056 057 120 127 128 129 134 135 140 143 145 147 151 156 159 173 193 219
HYPHER	009 159 163 171
ICE	009 010 064 108 171

BRANDS	CODES
IMPERIAL	043 049 108 139 144 154 165 255
INGERSOLL	171
INNO HIT	159 189 237
INTERBUY	010
INTERCORD	233
INTERFUNK	108 109 113 130 133 134 135 137 141 146 147 148 165 179 210
INTERVISION	010 086 108 132 144 166
IRRADIO	163 235 237
ITC	144 159
ITS	009 010 064 171
ITT	141 151 186
JVC	009 169
KAIDO	136
KAPSCH	089 147 148 197
KARCHER	084 108
KATHREIN	109
KAWA	009
KENDO	060 108 137 157
KENNEDY	197
KNEISSEL	108
KONKA	009
KORTING	086 204 209
KUBA	233
KUBA ELECTRONIC	233
KURA	134
LENCO	108 170
LG	001(Default) 038 050 108 110 136 144 159 163 166 171 191 219 237
LIESENKOTTER	108 210
LIFETEC	010 064 108 170
LOEWE	109 113 204 205
LOGIK	070 227
LUMA	137 197
LUXOR	102 104 132 133 134 135 138 140 143 145 153 156 174 186 237
M ELECTRONIC	103 104
MAGNADYNE	163 164 204
MAGNAFON	199
MAGNASONIC	108
MARANTZ	108
MARSHAL	064
MATSUI	009 016 025 060 061 062 063 070 108 131 136 152 154 159 171 172
MERRIT	132
METZ	047 092 097 098 100 101 108 204 207 254
mitsubishi	075 076 077 097 113 204 222 224 240
MIVAR	044 042 159 235
MNARTT	007
MTC	086 109 134

BRANDS	CODES
MULTITECH	136 159 171 185
MURPHY	232
NAONIS	137
NECKERMANN	037 059 060 092 098 100 101 108 109 113 115 118 119 134 135 137 143 157 159
NEI	064 108
NIKKAI	219
NIKKO	108
NOBLIKO	232 235
NOGAMATIC	173 179 239
NOKIA	014 019 032 102 103 104 108 132 133 134 135 138 140 141 145 146 147 148 156 174
NORDMENDE	129 173 179 180 181 193 195 225 226 228 239
NORMN	108
NOVA	087
OCEANIC	032 103 104 135 140 156
OKANO	108
ONWA	009 010 064
ORAVA	108
ORBITER	086
ORION	025 059 060 061 062 064 070 108 110 118 219
OSAKE	106
OTTO-VERSAND	002 005 009 014 059 060 081 082 083 085 092 097 098 100 101 108 109 111 113
PAEL	235
PANASONIC	002 003 005 167 168 229
PATHE CINEMA	144
PATHE MARCONI	173 179 225 239
PHILCO	090 108 139 144 148 165 204
PHILIPS	065 066 067 068 069 092 108 109 111 112 114 115 116 119 122 123 124 125 193 212 251 252
PIONEER	193
PRANDONI-PRINCE	137 235
PRIMA	219
PRO VISION	108
PROFEX	108 136 171
PROFITRONIC	108
QUELLE	002 010 014 019 025 059 060 072 084 086 087 088 092 097 098 100 101 102 175
RADIOLA	108
RADIOTONE	010 085 108 171
REDIFUSSION	187
BRANDS	CODES

REVOX	109
REX	088 089 137 157 158 164 197 246 247
RFT	064 085 135 204
RITAR	138
ROADSTAR	108
ROSITA	171
SABA	079 146 147 173 179 181 193 195 225 226 239
SAISHO	025 060 070 136 159
SAKIO	171
SALORA	019 032 103 104 132 133 134 135 137 138 140 142 143 145 150 156 174 237 241
SAMBERS	235
SAMSUNG	004 010 050 086 108 117 126 171 220 237
SANY	193
SANYO	014 018 019 020 032 034 071 086 087 189 218 221 222 223
SCHNEIDER	009 064 088 108 133 141 159 163 233
SEG	010 064 108 144 159 165 171 185 219
SEI-SINUDYNE	025 108 204 212
SELECO	088 089 137 157 197 222
SENTRA	064 133
SHARP	081 082 083 222
SHINTOM	108
SHINTOSHI	108
SHIVAKI	108
SIAREM	204
SIEMENS	092 096 097 098 100 101 108 210 218 219 221
SIESTA	085
SILVER	010 064
SINGER	108 164 204
SINUDYNE	118 131
SMARAGO	172
SOLAVOX	133
SONOLOR	140 156
SONTEC	108
SONY	072 074 211 212 213 214 215 216 217 222
SPECTRA	170
STARLITE	108 171
STARLUX	171
STERN	088 089 137 157 197
SUNSTAR	108 171

BRANDS	CODES
SUPERTECH	108 139 152 171
TADISTAR	108
TASHIKO	108 159 218
TEC	108 139 144 159 170 171
TECHLINE	185
TECHNISAT	108 165
TECNISON	108 171
TEKON	171
TELEAVIA	173 178 179 225 239
TELEFUNKEN	079 177 179 181 193 195 200 210
TELEOPTA	171
TELERNT	109
TELETECH	165 171
TELETEXT	115
TELETON	088
TELETON	089 134 159 197
TENSAI	064 108 144 149 171 191
TENSON	171
TESLA	204
THOMSON	052 078 079 134 173 178 179 181 193 195 225 239
THORN	011 014 016 018 026 028 066 072 075 087 097 102 108 116 135 141 145 146 160
THORN-FERGUSON	160 188 200 227
TOSHIBA	012 016 026 036 037 222 232
TOWADA	144 185
TRISTAR	010 064
TRIUMPH	025 219 236
UHER 089	108 109 149 185 197 233
ULTRAVOX	108 164 185 204
UNIVERSUM	174
UNIVOX	204
VESTEL	108
VIDEOSAT	165
VIDEOTON	178 193
VIDEOWAY	230
VISION	108 149
VOXSON	137 204
WALTHAM	178
WATSON	064 108 149 171
WEGA	208 222
WHITE	108 110 149
WESTINGHOUSE	
YOKO	010 064 108 136 144 159 164 170 171
ZANUSSI	137 197
ZENITH	231

Troubleshooting

General	
The power does not turned on.	<ul style="list-style-type: none"> ➔ Plug the power cord into the wall outlet securely.
There is no picture.	<ul style="list-style-type: none"> ➔ Select the appropriate video input mode on the TV so the picture from the recorder appears on the TV screen. ➔ Connect the video connection securely.
Picture noise appears.	<ul style="list-style-type: none"> ➔ The video signal from the external component is copy-protected. ➔ Set the resolution that your TV can accept. ➔
The programme is not found or stored.	<ul style="list-style-type: none"> ➔ Check your antenna connection.
There is no sound.	<ul style="list-style-type: none"> ➔ Connect the audio connection securely. ➔ The input source setting on the amplifier or the connection to the amplifier is incorrect. ➔ The recorder is in scan, slow motion, or pause mode. ➔ Try to select another audio channel or source using AUDIO button. ➔ Set the [Digital Output] option to the correct position (see page 46).
The remote control does not work properly.	<ul style="list-style-type: none"> ➔ The remote control is not pointed at the remote sensor of the recorder. ➔ The remote control is too far from the recorder. ➔ There is an obstacle in the path of the remote control and the recorder. ➔ The batteries in the remote control are exhausted.
The connected USB storage device is not recognized.	<ul style="list-style-type: none"> ➔ Try another different USB cable, some of USB cable may not support enough current for normal USB operation. ➔ If you use a USB extension cable or USB HUB, the USB devices may not be recognized. ➔ Try another USB storage device. ➔ This recorder supports only USB Flash Drive and USB External HDD with FAT16, FAT32 or NTFS format. ➔ An USB device which requires additional program installation when you have connected it to a computer is not supported.

Playback	
Cannot play MUSIC/ PHOTO/MOVIE files.	<ul style="list-style-type: none"> ➔ The files are not recorded in a format that the recorder can play. ➔ The recorder does not support the codec of the movie file.

Recording	
Cannot record or does not record successfully.	<ul style="list-style-type: none"> ➔ Check the remaining space on the HDD. ➔ If your source is copy-protected, you cannot record it using this recorder. ➔ If you set a DTV rating for the recorder and higher rated digital programs are received, the programme cannot be recorded. Change the DTV rating level in order to record it.
Timer record does not record successfully.	<ul style="list-style-type: none"> ➔ Clock is not set to correct time. ➔ The start time of the timer recording is past. ➔ Two timer recordings may have overlapped, in which case only the earlier one will record completely. ➔ When setting the recording programme, make sure you set the recorder's built-in tuner, not the TV's built-in tuner. ➔ If the HDD is damaged, the recording may not complete successfully.
You cannot enter a timer programme when	<ul style="list-style-type: none"> ➔ A recording is already underway. ➔ The time you're trying to set has already passed. ➔ There are already 32 timer programs set.
If two or more timer programs overlap	<ul style="list-style-type: none"> ➔ The earlier programme takes priority. ➔ The recorder can record 2 channels simultaneously but do not make overlap timer recording, may some programme cannot be recorded according to it's priority. ➔ If the HDD is damaged, the recording may not complete successfully. In this case even though the [Check] field shows [Ready], it may not be.

HDMI	
The connected HDMI device does not display any picture.	<ul style="list-style-type: none"> ➔ Try disconnecting then reconnecting the HDMI cable. ➔ Try switching the power of the HDMI device off then back on. ➔ The video input of the connected device is set correctly for this recorder. ➔ The HDMI cable you are using is fully HDMI-compliant. Using a non-standard cable may result in no picture being output. ➔ Not all HDCP-compatible DVI devices will work with this recorder.
The connected HDMI device does not output sounds.	<ul style="list-style-type: none"> ➔ Some HDMI-compatible devices do not output sounds. Check the manual that came with the connected device. ➔ If your TV is not capable of handling 96 kHz sampling frequency, set the [Sampling Freq.] option to [48 kHz] on the setup menu. When this choice is made, this recorder will automatically convert any 96 kHz signals to 48 kHz so your system can decode them. ➔ If your TV is not equipped with Dolby Digital, DTS and MPEG decoder, set the [Digital Output] option to [HDMI LPCM] on the setup menu.

Resetting the recorder	
If you observe any of the following symptoms.	<ul style="list-style-type: none"> ➔ The recorder is plugged in, but the power will not turn on or off. ➔ The front panel display is not working. ➔ The recorder is not operating normally.
You can reset the recorder as follows.	<ul style="list-style-type: none"> ➔ Press RESET button on the front pannel. This will force the recorder to power off then turn the recorder back on. ➔ Unplug the power cord, wait at least five seconds, and then plug it in again.

Customer Support

You can update this recorder using the latest software to enhance the products operation and/or add new features. To obtain the latest software for this recorder (if updates have been made), please visit <http://lgservice.com> or contact LG Electronics customer care center.

Specifications

General

Power requirements:	AC 200-240 V, 50/60 Hz
Power consumption:	30W
Dimensions (W x H x D):	Approx. 430 x 65.3 x 255 mm without foot
Net Weight (Approx.):	3.7 kg
Operating temperature:	5 °C to 35 °C
Operating humidity:	5 % to 90 %
Television system	DVB-T Standard Compliant

TV Recording

Recording format:	TS (Transport Stream format)
Recordable media:	Hard Disk Drive (MS408D: 250GB / MS409D: 500GB), External Disk Drive, USB 2.0 HDD

Connectors

ANTENNA IN:	Antenna input, 75 ohms
VIDEO OUT:	1.0 V (p-p), 75 Ω, sync negative, RCA jack x 1
COMPONENT VIDEO OUT:	(Y) 1.0 V (p-p), 75 Ω, sync negative, RCA jack x 1 (Pb)/(Pr) 0.7 V (p-p), 75 Ω, RCA jack x 2
HDMI OUT (video/audio):	19 pin (HDMI standard, Type A)
ANALOG AUDIO OUT:	2.0 Vrms (1 kHz, 0 dB), 600 Ω, RCA jack (L, R) x 1
DIGITAL OUT (COAXIAL):	0.5 V (p-p), 75 Ω, RCA jack x 1
DIGITAL OUT (OPTICAL):	3 V (p-p), Optical jack x 1
USB Port:	4 pin (USB 2.0 standard) x 2

System

LAN port:	Ethernet jack x 1, 10BASE-T/100BASE-TX
Wireless LAN: (internal antenna)	Integrated IEEE 802.11n (Draft 2.0) wireless networking access, compatible with 802.11b/g/n Wi-Fi networks.
Bus power supply (USB):	DC 5 V $\overline{\text{---}}$ 1 A (Front), DC 5 V $\overline{\text{---}}$ 500 mA (Rear)

Accessories

Video/Audio cable (1), Remote control (1), Batteries (2), Nero MediaHome 4 Essentials software CD-ROM (1), Wireless LAN Adapter (USB type) (1), Screws (4)

- Design and specifications are subject to change without notice.

IMPORTANT INFORMATION RELATING TO NETWORK SERVICES

PLEASE READ CAREFULLY. USE OF THE NETWORK SERVICES IS SUBJECT TO THE FOLLOWING TERMS AND CONDITIONS.

Use of the Network Services requires an Internet connection which is sold separately and for which you are solely responsible. The Network Services may be limited or restricted depending upon the quality, capabilities and technical limitations of your Internet service.

The Network Services belong to third parties and may be protected by copyright, patent, trademark and/or other intellectual property laws. The Network Services are provided solely for your personal and noncommercial use. Unless expressly authorized by the respective content owner or service provider, you shall not modify, copy, republish, upload, post, transmit, translate, sell, create derivative works, exploit, or distribute in any manner or medium any content or services accessible through this product.

LG IS NOT RESPONSIBLE FOR YOUR USE OF THE NETWORK SERVICES. THE NETWORK SERVICES ARE PROVIDED "AS IS." TO THE FULLEST EXTENT PERMISSIBLE BY LAW, LG MAKES NO REPRESENTATIONS OR WARRANTIES OF ANY KIND WHATSOEVER (i) FOR THE ACCURACY, VALIDITY, TIMELINESS, LEGALITY, OR COMPLETENESS OF ANY NETWORK SERVICE MADE AVAILABLE THROUGH THIS PRODUCT; OR (ii) THAT THE NETWORK SERVICES ARE FREE OF VIRUSES OR OTHER COMPONENTS THAT MAY INFECT, HARM, OR CAUSE DAMAGE TO THIS PRODUCT, YOUR COMPUTER, TELEVISION, OTHER EQUIPMENT, OR ANY OTHER PROPERTY. LG EXPRESSLY DISCLAIMS ANY IMPLIED WARRANTIES, INCLUDING BUT NOT LIMITED TO, WARRANTIES OF MERCHANTABILITY OR FITNESS FOR A PARTICULAR PURPOSE.

UNDER NO CIRCUMSTANCES AND UNDER NO LEGAL THEORY, WHETHER IN CONTRACT, TORT, STRICT LIABILITY OR OTHERWISE, SHALL LG BE LIABLE TO YOU OR ANY THIRD PARTY FOR ANY DIRECT, INDIRECT, INCIDENTAL, SPECIAL, STATUTORY, CONSEQUENTIAL OR OTHER DAMAGES OR ATTORNEY FEES OR EXPENSES RELATING TO OR ARISING OUT OF THE NETWORK SERVICES EVEN IF ADVISED OF THE POSSIBILITY OF SUCH DAMAGES OR IF SUCH DAMAGES COULD HAVE BEEN REASONABLY FORESEEN.

The Network Services may be terminated or interrupted at any time, and LG makes no representation or warranty that any Network Service will remain available for any period of time. Use of the Network Services may be subject to additional terms and conditions of the respective third party service provider. The Network Services are transmitted by third parties by means of networks and transmission facilities over which LG has no control. LG EXPRESSLY DISCLAIMS ANY RESPONSIBILITY OR LIABILITY FOR ANY INTERRUPTION OR SUSPENSION OF ANY NETWORK SERVICE.

LG shall be neither responsible nor liable for customer service related to the Network Services. Any question or request should be made directly to the respective Network Service providers.

"Network Service(s)" means the third party services accessible through this product including but not limited to all data, software, links, messages, video and other content found thereon or used in connection therewith.

"LG" means LG Electronics, Inc. its parent company and all of their respective subsidiaries, affiliates and related companies worldwide.

Open source software notice

The following GPL executables and LGPL libraries used in this product are subject to the GPL2.0/LGPL2.1 License Agreements:

GPL EXECUTABLES:

Linux kernel, busybox, dosfstools, gdbserver, ntfprogs, udfstools, wireless-tools

LGPL LIBRARIES:

ebase, mplib, neon, qDecoder, uClibc

LG Electronics offers to provide source code to you on CD-ROM for a charge covering the cost of performing such distribution, such as the cost of media, shipping and handling upon e-mail request to LG Electronics at: opensource@lge.com

This offer is valid for a period of three (3) years from the date of the distribution of this product by LG Electronics.

You can obtain a copy of the GPL, LGPL licenses from <http://www.gnu.org/licenses/old-licenses/gpl-2.0.html> and <http://www.gnu.org/licenses/old-licenses/lgpl-2.1.html> .

You can also obtain a copy of translations from <http://www.gnu.org/licenses/old-licenses/gpl-2.0-translations.html> and <http://www.gnu.org/licenses/old-licenses/lgpl-2.1-translations.html>

This software is based in part on the work of the Independent JPEG Group copyright © 1991 – 1998, Thomas G. Lane.

This product includes

- Freetype : copyright © 2003 The FreeType Project (www.freetype.org).
- Libpng : copyright © 2004 Glenn Randers-Pehrson
- Zlib : Copyright © 1995-2002 Jean-loup Gailly and Mark Adler.
- OpenSSL:
 - cryptographic software written by Eric Young (ey@cryptsoft.com).
 - software written by Tim Hudson (tjh@cryptsoft.com).
 - software developed by the OpenSSL Project for use in the OpenSSL Toolkit. (<http://www.openssl.org>)
- Tinyxml : copyright © 2000-2006 Lee Thomason
- WPA Supplicant : Copyright © 2003-2007, Jouni Malinen <jj@w1.fi> and contributors
- miniUPnP client: Copyright © 2005-2006, Thomas BERNARD
- giflib: Copyright © 1997 Eric S. Raymond
- regex : Copyright © 1992, 1993, 1994, 1997 Henry Spencer

All rights reserved.

Permission is hereby granted, free of charge, to any person obtaining a copy of this software and associated documentation files (the "Software"), to deal in the Software without restriction, including without limitation the rights to use, copy, modify, merge, publish, distribute, sublicense, and/or sell copies of the Software, and to permit persons to whom the Software is furnished to do so, subject to the following conditions:

THE SOFTWARE IS PROVIDED "AS IS", WITHOUT WARRANTY OF ANY KIND, EXPRESS OR IMPLIED, INCLUDING BUT NOT LIMITED TO THE WARRANTIES OF MERCHANTABILITY, FITNESS FOR A PARTICULAR PURPOSE AND NONINFRINGEMENT. IN NO EVENT SHALL THE AUTHORS OR COPYRIGHT HOLDERS BE LIABLE FOR ANY CLAIM, DAMAGES OR OTHER LIABILITY, WHETHER IN AN ACTION OF CONTRACT, TORT OR OTHERWISE, ARISING FROM, OUT OF OR IN CONNECTION WITH THE SOFTWARE OR THE USE OR OTHER DEALINGS IN THE SOFTWARE.

