



OWNER'S MANUAL

COMMERCIAL WASHER

Please read this manual carefully before operating your set and retain it for future reference.

MODEL
WD-10467BD

PRODUCT FEATURES

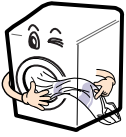

■ Direct Drive System

The advanced Brushless DC motor directly drives the drum without using a belt and pulley.

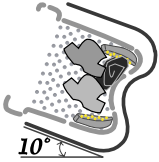

■ Tilted Drum and Extra Large Door Opening

The tilted drum and extra large opening make it possible to load and unload clothing more easily.

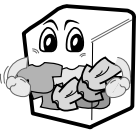

■ Ultra Capacity

The larger drum enables more tumbling action and greater centrifugal force, but also less tangling and wrinkling of the laundry. Heavier loads, such as king size comforters, blankets, and curtains, can be washed.

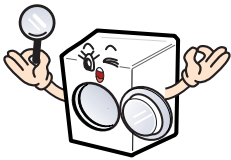

■ See-through Door and Big Door

You can see the laundry throughout the cycle.



■ Stainless Steel Drum

The stainless steel drum doesn't rust.

CONTENTS

PART 1. IMPORTANT SAFETY INSTRUCTIONS	3
PART 2. SPECIFICATIONS.....	6
PART 3. IDENTIFICATION	7
PART 4. OPERATING YOUR WASHER	9
PART 5. PROGRAMMING MODE.....	10
PART 6. ERROR MODE.....	23
PART 7. POWER FAIL RECOVERY	24
PART 8. DEFAULT WASHER SETTINGS.....	24

READ ALL INSTRUCTIONS BEFORE USE

WARNING

For your safety, the information in this manual must be followed to minimize the risk of fire or explosion, electric shock, or to prevent property damage, personal injury, or loss of life.

Your safety and the safety of others are very important.

We have provided many important safety messages in this manual and on your appliance. Always read and obey all safety messages.



This is the safety alert symbol.

This symbol alerts you to potential hazards that can kill or hurt you and others.

All safety messages will follow the safety alert symbol and either the word DANGER or WARNING.

These words mean:

 DANGER: You can be killed or seriously injured if you don't follow instructions.

 WARNING: You can be killed or seriously injured if you don't follow instructions.

All safety messages will tell you what the potential hazard is, tell you how to reduce the chance of injury, and tell you what can happen if the instructions are not followed.

IMPORTANT SAFETY INSTRUCTIONS

 WARNING: To reduce the risk of fire, electric shock, or injury to persons when using the washer, follow basic precautions, including the following:

- Read all instructions before using the washer.
- Do not wash articles that have been previously cleaned in, washed in, soaked in, or spotted with gasoline, dry cleaning solvents, or other flammable or explosive substances, as they give off vapors that could ignite or explode.
- Do not add gasoline, dry cleaning solvents, or other flammable or explosive substances to the wash water. These substances give off vapors that could ignite or explode.
- Under certain conditions, hydrogen gas may be produced in a hot water system that has not been used for 2 weeks or more. **HYDROGEN GAS IS EXPLOSIVE.** If the hot water system has not been used for such a period, before using the washing machine, turn on all hot water faucets and let the water flow from each for several minutes. This will release any accumulated hydrogen gas. As the gas is flammable, do not smoke or use an open flame during this time.
- Do not allow children to play on or in the washer. Close supervision of children is necessary when the washer is used near children.
- Before the washer is removed from service or discarded, remove the door to prevent children from hiding inside.
- Do not install or store the washer where it will be exposed to the weather.
- Do not tamper with the controls.
- Do not repair or replace any part of the washer or attempt any servicing unless specifically recommended in the user-maintenance instructions or published user-repair instructions that you understand and have the skills to carry out.
- See **Installation Instructions** for grounding requirements.
- **ALWAYS** follow the fabric care instructions supplied by the garment manufacturer.
- Do not place items exposed to cooking oil in your washer. Items contaminated with cooking oils may contribute to a chemical reaction that could cause a load to catch fire.
- Do not use fabric softeners or products to eliminate static unless recommended by the manufacturer of the fabric softener or product.

SAVE THESE INSTRUCTIONS

GROUNDING INSTRUCTIONS

This appliance must be grounded. In the event of malfunction or breakdown, grounding will reduce the risk of electric shock by providing a path of least resistance for electric current. This appliance is equipped with a cord having an equipment-grounding conductor and grounding plug. The plug must be plugged into an appropriate outlet that is properly installed and grounded in accordance with all local codes and ordinances.

- Do not use an adapter or extension cord.
- Do not remove ground prong.
- If you don't have the proper outlet, consult an electrician.

 WARNING: Improper connection of the equipment-grounding conductor can result in risk of electric shock. Consult a qualified electrician or serviceman if you are in doubt as to whether the appliance is properly grounded. Do not modify the plug provided with the appliance - if it does not fit the outlet, have a proper outlet installed by a qualified electrician.

READ ALL INSTRUCTIONS BEFORE USE

⚠ WARNING

For your safety, the information in this manual must be followed to minimize the risk of fire or explosion, electric shock, or to prevent property damage, personal injury, or loss of life.

SAFETY INSTRUCTION FOR INSTALLATION

⚠ WARNING

To reduce the risk of fire, electric shock, or injury to persons when using the appliance, follow basic precautions, including the following:

- **Refer to INSTALLATION INSTRUCTIONS for detailed grounding procedures.**
Installation instructions are packed in the washer for installer's reference. If the washer is moved to a new location, have it checked and reinstalled by a qualified service person. Failure to follow this warning can cause serious injury, fire, electrical shock or death.
- **Do not, under any circumstances cut or remove the third (ground) prong from the power cord.**
Failure to follow this warning can cause serious injury, fire, electrical shock or death.
- **For personal safety, this appliance must be properly grounded.**
Failure to follow this warning can cause serious injury, fire, electrical shock or death.
- **The power cord of this appliance is equipped with a 3-prong (grounding) plug which fits a standard 3-prong (grounding) wall outlet to minimize the possibility of electric shock hazard from this appliance.**
- **This washer must be plugged into a 220-VAC, 50 Hz grounded outlet.** Failure to follow this warning can cause serious injury, fire, electrical shock, or death.
- **Have the wall outlet and circuit checked by a qualified electrician to make sure the outlet is properly grounded.** Failure to follow this warning can cause serious injury, fire, electrical shock, or death.
- **Where a standard 2-prong wall outlet is encountered, it is your personal responsibility and obligation to have it replaced with a properly grounded 3-prong wall outlet.** Failure to follow this warning can cause serious injury, fire, electrical shock, or death.
- **Do not install on carpet. Install the washer on a solid floor.** Failure to follow this warning can cause serious leak damage.
- **Do not remove the ground prong. Do not use an adapter or extension cord. Plug into a grounded 3 prong outlet.**
Failure to follow this warning can cause serious injury, fire, electrical shock, or death.
- **The washer should always be plugged into its own individual electrical outlet which has a voltage rating that matches the rating plate.**
This provides the best performance and also prevents overloading house wiring circuits which could cause a fire hazard from overheated wires.
- **Never unplug your washer by pulling on the power cord. Always grip the plug firmly and pull straight out from the outlet.** Failure to follow this warning can cause serious injury, fire, electrical shock, or death.
- **Repair or replace all power cords that have become frayed or otherwise damaged. Do not use a cord that shows cracks or abrasion damage along its length or at either end.**
Failure to follow this warning can cause serious injury, fire, electrical shock, or death.
- **When installing or moving the washer, be careful not to pinch, crush, or damage the power cord.** Failure to follow this warning can cause serious injury, fire, electrical shock, or death.
- **The washer must be installed and electrically grounded by a qualified service person in accordance with local codes,** to prevent shock hazard and assure stability during operation.
- **The washer is heavy. Two or more people are needed to install and move the appliance.**
Failure to do so can result in back or other injury
- **Store and install the washer where it will not be exposed to temperatures below freezing or exposed to outdoor weather conditions.**
Failure to follow this warning can cause serious leak damage.
- **Do not install the washer in humid spaces to reduce the risk of electric shock.**
Failure to follow this warning can cause serious injury, fire, electrical shock, or death.

READ ALL INSTRUCTIONS BEFORE USE**▲ WARNING**

For your safety, the information in this manual must be followed to minimize the risk of fire or explosion, electric shock, or to prevent property damage, personal injury, or loss of life.

SAFETY INSTRUCTION FOR SAFETY USE/CLEANING/CARE/DISCARD**▲ WARNING**

To reduce the risk of fire, electric shock or injury to persons when using the appliance, follow basic precautions, including the following:

- **Unplug the washer before cleaning** to avoid the risk of electric shock.
- **Never use harsh chemicals, abrasive cleaners, or solvents to clean the washer.** They will damage the finish.
- **Do not put oily or greasy rags or clothing on top of the washer.** These substances give off vapors that could ignite the materials.
- **Do not wash items that are soiled with vegetable or cooking oil.** These items may contain some oil after laundering. Due to the remaining oil, the fabric may smoke or catch fire by itself.
- **Disconnect this appliance from the power supply before attempting any user maintenance.** Turning the controls to the OFF position does not disconnect this appliance from the power supply. Failure to follow this warning can cause serious injury, fire, electrical shock, or death.
- **Do not combine laundry products for use in 1 load unless specified on the label. Do not mix chlorine bleach with ammonia or acids such as vinegar.** Follow package directions when using laundry products. Incorrect usage can produce poisonous gas resulting in serious injury or death.
- **Do not reach into the washer while parts are moving. Before loading, unloading, or adding items, push in the cycle selector knob and allow the drum to coast to a complete stop before reaching inside.** Failure to follow this warning can cause serious injury, fire, electrical shock, or death.
- **Do not allow children to play on or in the washer.** Close supervision of children is necessary when the washer is used near children. As children grow, teach them the proper, safe use of all appliances. Failure to comply with these warnings could result in serious personal injuries.
- **Destroy the carton, plastic bag, and other packing materials after the washer is unpacked.** Children might use them for play. Cartons covered with rugs, bedspreads or plastic sheets can become airtight chambers. Failure to comply with these warnings could result in serious personal injuries.
- **Keep laundry products out of children's reach.** To prevent personal injury, observe all warnings on product labels. Failure to comply with these warnings could result in serious personal injuries.
- **Remove the door to the washing compartment to avoid the danger of children or small animals getting trapped inside before your washer is removed from service or discarded.** Failure to do so can result injury or death.
- **Before the washer is removed from service or discarded, remove the washer door to prevent accidental entrapment.** Failure to comply with these warnings could result in serious personal injuries.

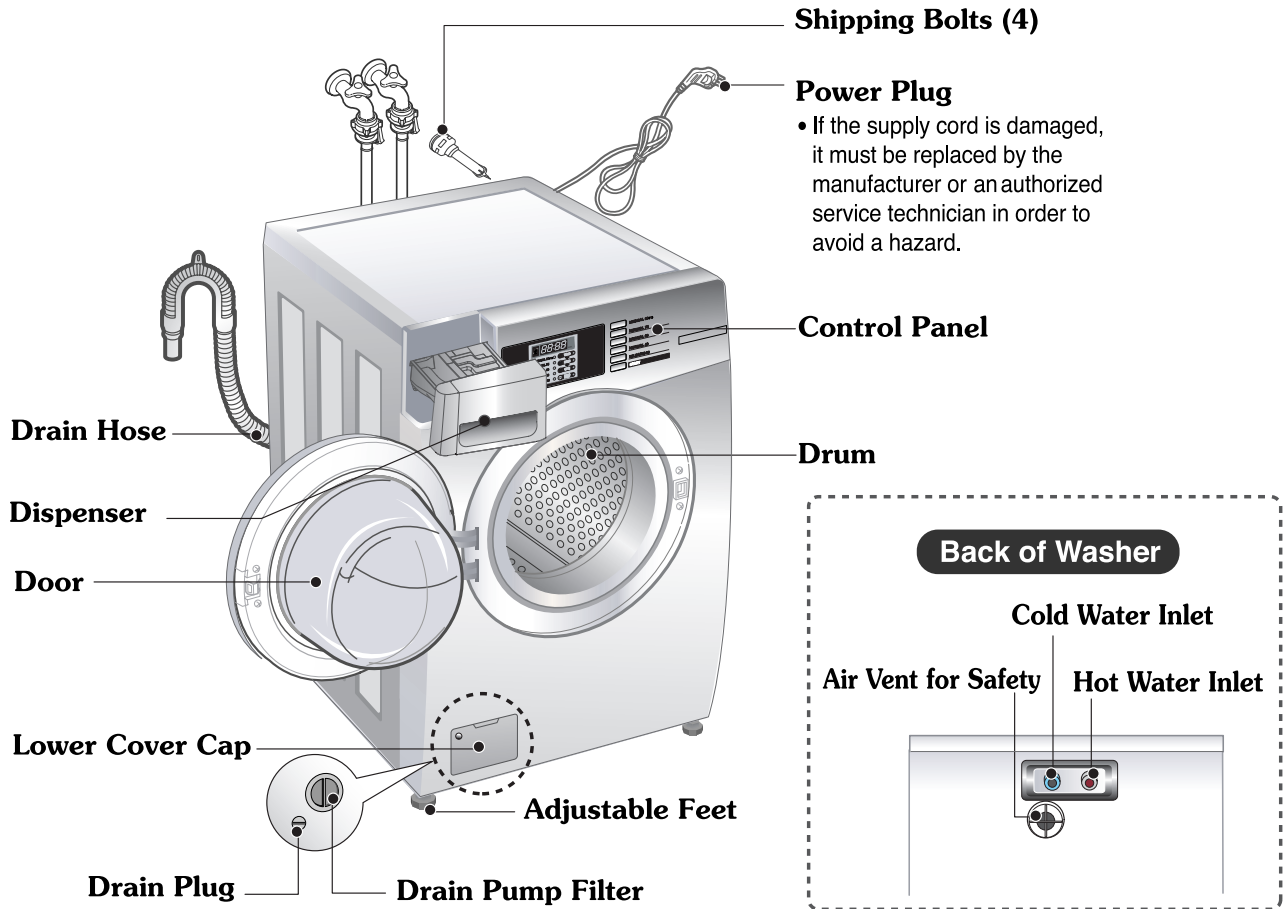

- Name: Front-loading Washing Machine
- Power supply: 220V~ 50Hz
- Size: 68.6 cm (W) X 75.6 cm (D) X 98.3 cm (H), 129.1 cm (D with door open)
27"(W) X 29³/₄"(D) X 38¹¹/₁₆"(H), 50¹³/₁₆"(D with door open)
- Weight: 190 lbs. (86 kg)
- Wash capacity: 13 kg
- Spin speed: 1000 rpm max.
- Permissible water pressure: 14.5~116 psi (100~800 kPa)

Note

Specifications subject to change by manufacturer.

■ **Accessories**

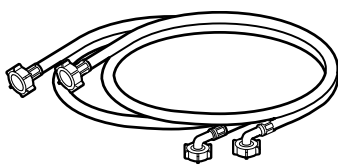

Hot/Cold (1 each)
Hose

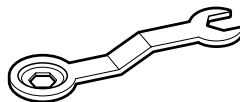

Wrench

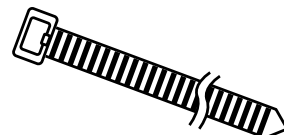

Tie strap
to secure drain hose to standpipe,
inlet hose, or laundry tub

■ WD-10467BD

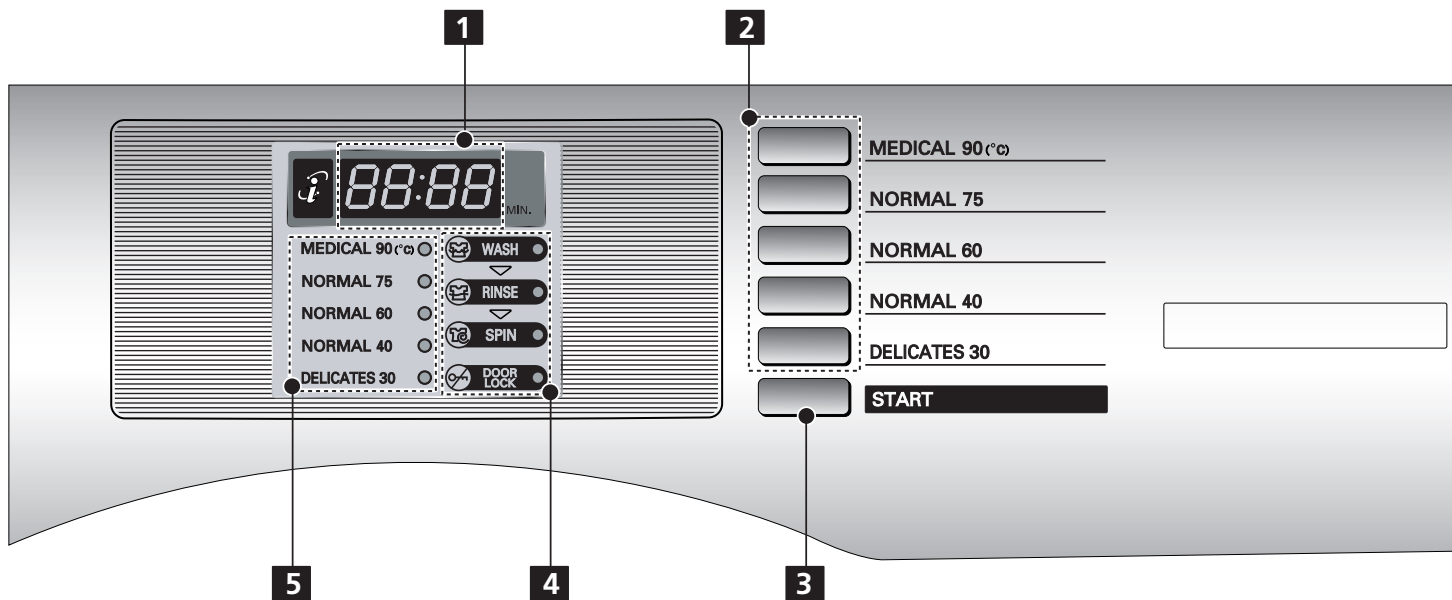

- 1. DISPLAY LED
- 2. CYCLE BUTTON
- 3. START BUTTON

- 4. STATUS LED
- 5. CYCLE LED

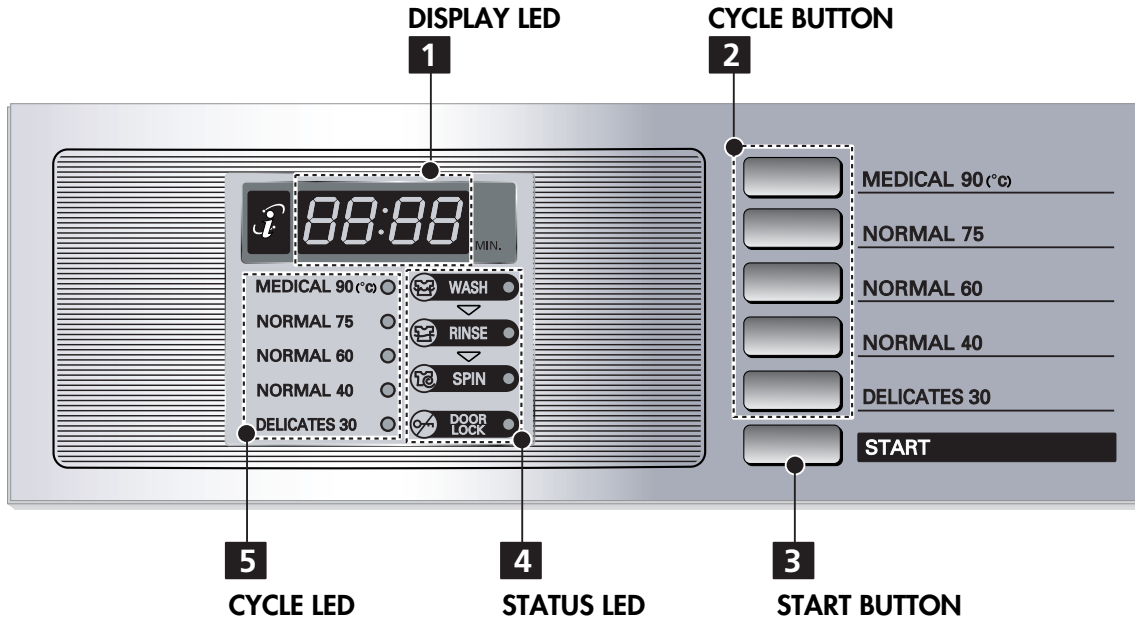

1 DISPLAY LED

The display shows the vend price and remaining time and programming options. In addition to this, if the appliance has a problem, it displays error messages.



2 CYCLE BUTTON

By pressing the cycle button, select the desired cycle based on laundry types and conditions.

* MEDICAL 90

Use it for the more medical wash than NORMAL 75 such as white clothes, baby clothes, sheets and underwear.

* NORMAL 75

Use it for heavy soiled fabrics such as white clothes, baby clothes, sheet and underwear.

* NORMAL 60

Use it for heavy soiled fabrics such as baby wear, underwear and white clothes.

* NORMAL 40

Use it for normal soiled fabrics such as cotton, linen, towels, shirts and jeans.

* DELICATES 30

Use it for lightly soiled fabrics such as delicate fabrics, washable woolens.

3 START BUTTON

The START LED flashes when the full vend price has been satisfied then the cycle has been chosen.

4 STATUS LED

- WASH LED flashes whenever the washing cycle is in operation.
- RINSE LED flashes whenever the Rinsing cycle is in operation.
- SPIN LED flashes whenever the Spining cycle is in operation.
- DOOR LOCK LED flashes whenever the door lock is in operation.

5 CYCLE LED

MEDICAL 90, NORMAL 75, NORMAL 60, NORMAL 40, and DELICATES 30 is lit for the cycle is in operation.

1 Ready mode

The cycle LEDs is lit at the same time, and displayed 'PUSH'.

2 Select the cycle

Press the desired button and press the start button. The display LED will show the remaining time and the selected cycle starts.

■ Select cycles designed for different types of fabric and soil levels.

Cycle	Wash/Rinse Temp.	Spin Speed
MEDICAL 90	Extra Hot/Cold	High
NORMAL 75	Extra Hot/Cold	High
NORMAL 60	Hot/Cold	High
NORMAL 40	Warm/Cold	High
DELICATES 30	Cold/Cold	Low

3 Change course

You cannot change the course while the machine is running.

4 Cycle finish

The machine stops and LED display shows "End" with beeper sound.

* Do not work any button and stop the washer (When the washer is operating) or (when a cycle is in progress)

✿ Programming mode

: You can check machine information or change setting on “Program setup”, ”Diagnostic Test”.
There are two methods that you can enter programming mode.

✿ Case1. Check the programming mode by button

How to enter "Programming mode"

You can enter programming mode only for ready step and pause step.

- Noncoin type

- 1) Push the MEDICAL 90 and NORMAL 60 button at the same time.
- 2) Push the NORMAL 75 button 3times.
- 3) Push the START button.
- 4) ‘LqC1’ will show on the display.

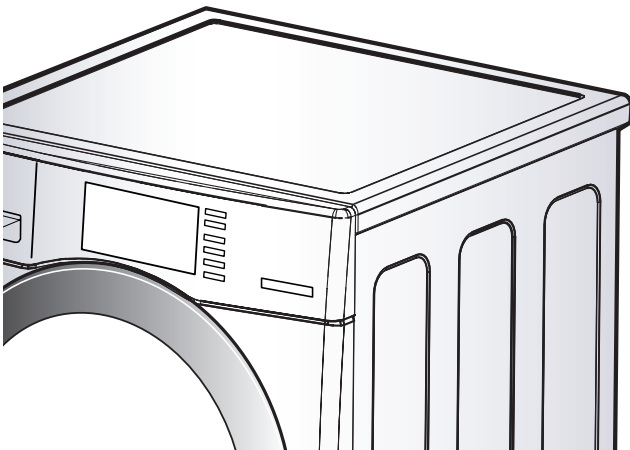

- NONCOIN TYPE -

How to use button

You can change Washer vend price, cycle time and Cycle parameters, etc.

Press Button	Description
MEDICAL 90	Move to upper level or Comes back to Idle State
NORMAL 75	Move to the mode in the same level (+)
NORMAL 60	Move to the modes in the same level (-)
START	Enter the selected mode

- Algorithm flow chart shows how to control programming mode.
- Before program set, check the structure of programming mode.

- The method of entering set up mode.
 - 1) Push the MEDICAL 90 and NORMAL 60 button at the same time.
 - 2) Push the NORMAL 75 button 3times.
 - 3) Push the START button.
 - 4) 'LqC1' will show on the display.
2. Press the MEDICAL 90 button to move to the upper level.
3. Press the NORMAL 75 or the NORMAL 60 button if you want to be at the same level.
4. Press START button to enter the details of Set up, Diagnostic Tests.

SE UP is to set price value, time value, and vend type etc.

EE SE consists of line test, reset, free cycle, and kill cycle.

EL EE Is to collect the usage data (Card type or coin type setup).



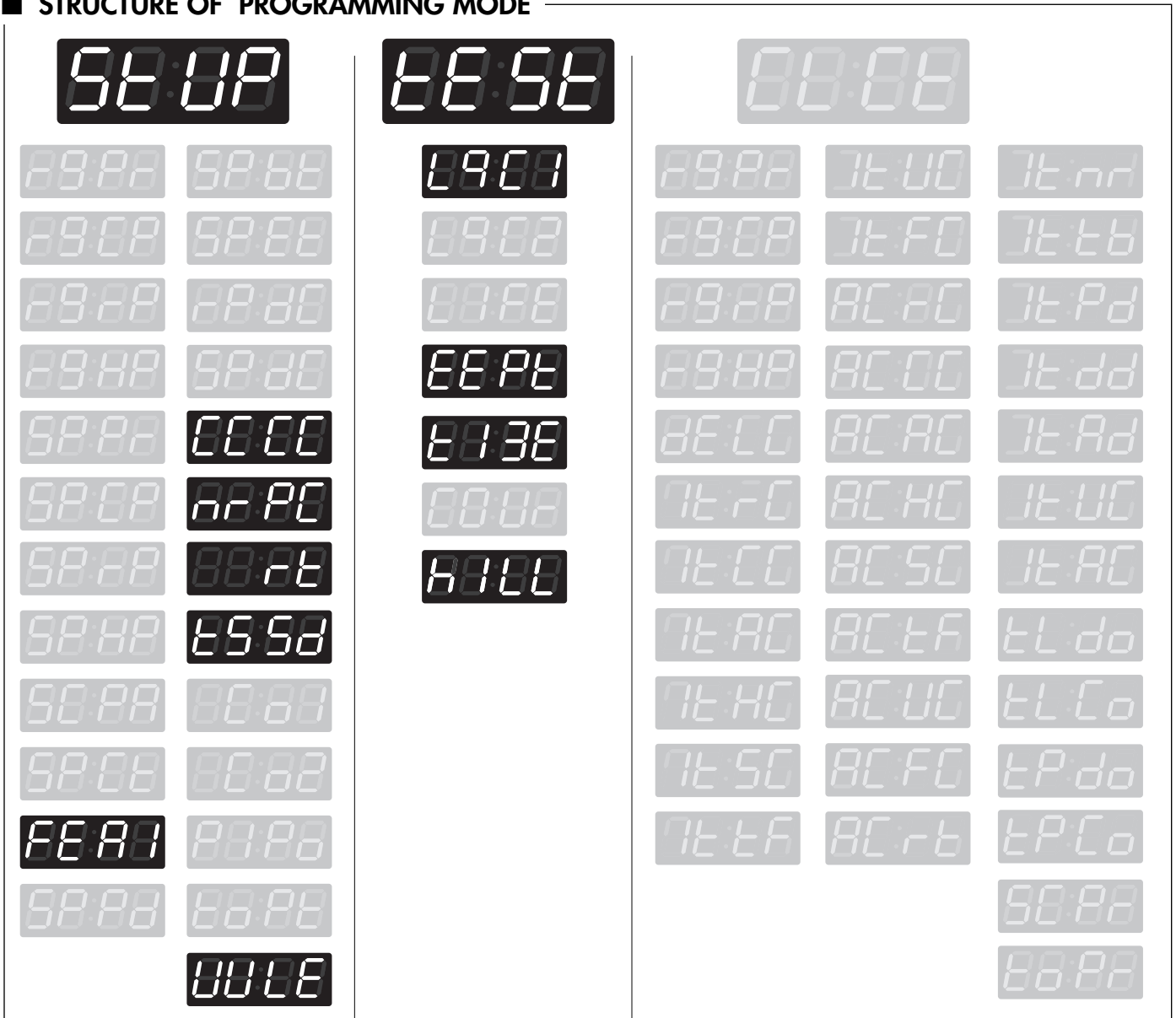

■ STRUCTURE OF PROGRAMMING MODE



Note

- Do not use **L9:02**, **L1:FE**.
- It is only used in inspecting the machine.





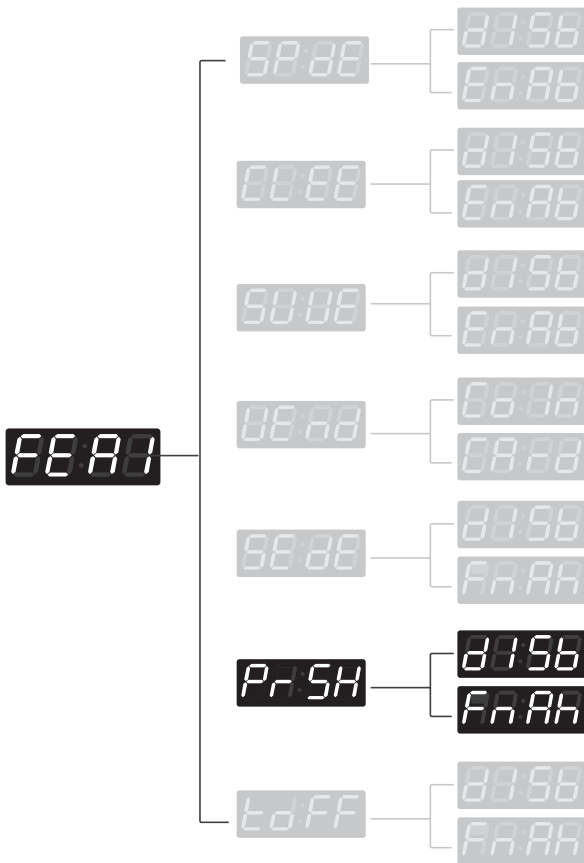

1 How to enter the **FEA1**

	Button	Display
<p>Entering set up mode. You will see LqC1</p> 	<p>Press the MEDICAL 90 button.</p>	
	<p>Press the NORMAL 75 or the NORMAL 60 button until SE UP appears in the display.</p>	
	<p>Press the START button.</p>	
	<p>Press the NORMAL 75 or the NORMAL 60 button until FEA1 appears in the display.</p>	











■ Structure of **FEA1**

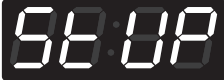

■ Content of **FEA1**

-  • Special price days apply or not
-  • Clear escrow enable or not (coin type only)
-  • Add super wash apply or not
-  • Select vend type
-  • Sense dry apply or not (only for dryer)
-  Pre-wash apply or not
-  Top off apply or not (only for dryer)









2 Pre-wash set up

	Button	Display
<p>Entering set up mode. You will see LqC1</p> 	<p>Press the MEDICAL 90 button.</p>	
	<p>Press the NORMAL 75 or the NORMAL 60 button until SEUP appears in the display.</p>	
	<p>Press the START button.</p>	
	<p>Press the the NORMAL 75 or the NORMAL 60 button until FEA1 appears in the display.</p>	
	<p>Press the START button. Display P7 5H.</p>	
	<p>Press the START button. Press the NORMAL 75 or the NORMAL 60 button and then select D1 56 or EA AB.</p> <div style="display: flex; justify-content: space-around; align-items: center;"> <div style="text-align: center;">  <p>Disable</p> </div> <div style="text-align: center;">  <p>Enable</p> </div> </div>	<p>One or the other will display.</p> <div style="display: flex; justify-content: space-around; align-items: center;">   </div>
	<p>Press the START button. The machine sets up the special price day.</p>	
	<p>1. Continue to set up the next mode. 2. Stop the change of setup value and go back to ready mode. • Noncoin type – Press MEDICAL 90 button until ready mode appears in the display.</p>	







Note

- toFF (top off) is not available in washer (Only for dryer)

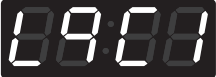





3 Washing time set up

	Button	Display
<p>Entering set up mode. You will see LqC1</p> 	Press the MEDICAL 90 button.	
	Press the NORMAL 75 or the NORMAL 60 button until  appears in the display.	
	Press the START button.	
	Press the NORMAL 75 or the NORMAL 60 button until  appears in the display.	
	Press the START button. Display previous wash time.	
	Press the NORMAL 75(+) or the NORMAL 60(-) button to select wash time. (Maximum 15 minutes, Minimum 5 minutes.)	
	Press the START button. The machine sets up the wash time, then advances to the next process automatically.	
	<ol style="list-style-type: none"> 1. Continue to set up the next mode. 2. Stop the change of setup value and go back to ready mode. <ul style="list-style-type: none"> • Noncoin type – Press MEDICAL 90 button until ready mode appears in the display. 	







4 Rinsing times per cycle

	Button	Display
<p>Entering set up mode. You will see LqC1</p> 	Press the MEDICAL 90 button.	
	Press the NORMAL 75 or the NORMAL 60 button until SE UP appears in the display.	
	Press the START button.	
	Press the NORMAL 75 or the NORMAL 60 button until RF PE appears in the display.	
	Press the START button. Display previous rinsing times per cycle.	
	Press the NORMAL 75(+) or the NORMAL 60(-) button to select rinsing times per cycle.(Max 5, Min 1)	
	Press the START button. The machine sets up the rinsing times per cycle, then advances to the next process automatically.	
	<ol style="list-style-type: none"> 1. Continue to set up the next mode. 2. Stop the change of setup value and go back to ready mode. <ul style="list-style-type: none"> • Noncoin type – Press MEDICAL 90 button until ready mode appears in the display. 	

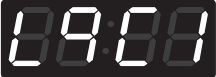
5 Rinsing time setup

	Button	Display
<p>Entering set up mode. You will see LqC1</p> 	Press the MEDICAL 90 button.	
	Press the NORMAL 75 or the NORMAL 60 button until SE UP appears in the display.	
	Press the MEDICAL 90 button.	
	Press the NORMAL 75 or the NORMAL 60 button until 88:70 appears in the display.	
	Press the START button. Display previous rinsing time.	
	Press the NORMAL 75(+) or the NORMAL 60(-) button to select rinse cycle. (Max 15min, Min 8min)	
	Press the START button. The machine sets up the rinsing time, then advances to the next process automatically.	
	1. Continue to set up the next mode. 2. Stop the change of setup value and go back to ready mode. • Noncoin type – Press MEDICAL 90 button until ready mode appears in the display.	

6 Top spin speed – final spin time depends on RPM

	Button	Display
<p>Entering set up mode. You will see LqC1</p> 	Press the MEDICAL 90 button.	
	Press the NORMAL 75 or the NORMAL 60 button until SE UP appears in the display.	
	Press the START button.	
	Press the NORMAL 75 or the NORMAL 60 button until 05:58 appears in the display.	
	Press the START button. Display previous top spin speed.	
	Press the NORMAL 75(+) or the NORMAL 60(-) button to select top spin speed. (0~4)	
	Press the START button. The machine sets up the top spin speed, then advances to the next process automatically.	
	<ol style="list-style-type: none"> 1. Continue to set up the next mode. 2. Stop the change of setup value and go back to ready mode. <ul style="list-style-type: none"> • Noncoin type – Press MEDICAL 90 button until ready mode appears in the display. 	

Note

Top spin speed

0: 1000rpm	3: 600 rpm
1: 900 rpm	4: 400 rpm
2: 800 rpm	









If you select 800 or below, the final spin time will be reduced by 9minutes

If you select 1000 ,900 rpm , the final spin time is fixed by 13 minutes

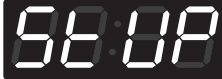
7 How to change the water level

You can change the water level by selecting two options.

1. LO indicate water level 23.8 [KHz]
2. HI indicate water level 23.7 [KHz]

	Button	Display
<p>Entering set up mode. You will see LqC1</p> 	<p>Press the MEDICAL 90 button.</p>	
	<p>Press the NORMAL 75 or the NORMAL 60 button until SE UP appears in the display.</p>	
	<p>Press the START button.</p>	
	<p>Press the NORMAL 75 or the NORMAL 60 button until WULE appears in the display.</p>	
	<p>Press the START button. Press the NORMAL 75 or the NORMAL 60 button and then select LO or HI LO 23.8 [KHz] HI 23.7 [KHz]</p>	<p>One or the other will display.</p>  
	<p>Press the NORMAL 75(+) or the NORMAL 60(-) button to select value of PIPo. (0~4)</p>	
	<p>Press the START button. The machine sets up the value of PIPo, then advances to the next process automatically.</p>	
	<p>1. Continue to set up the next mode. 2. Stop the change of setup value and go back to ready mode. • Noncoin type – Press MEDICAL 90 button until ready mode appears in the display.</p>	

Note

- This function is only controlled in machine.
(It is not applied in setup card.)

Diagnostic tests: **EE5E** (display)

This program has been added for testing the washer and detecting errors.

Entering the test mode

Data Name	Button	Display	Description
Entering the test mode	1. Entering programming mode	L9C1	Push and hold the MEDICAL 90 and NORMAL 60 at the same time. After that push NORMAL 75 button for 3 times. Push START button.
	2. MEDICAL 90	EE5E	Press the MEDICAL 90 button. Then EE5E appears in the display.
	3. START	L9C1	Enter the diagnostic test mode.

1 **L9C1**

According to pressing START button, test move to the next step.









Number of times the START button is pressed	Check Point	Display
None		L9C1
1time	Turns on all lamps and locks the door	Displayed EU XX and LE XX alternately (Version)
2 times	Tumble Clockwise.	rpm (40~50)
3 times	Low Speed Spin	rpm (600)
4 times	High Speed Spin	rpm (1000)
5 times	Inlet valve for main water turns on.	Water level frequency (261~)
6 times	Inlet valve for hot wash turns on.	Water level frequency (261~)
7 times	Inlet valve for softener turns on.	Water level frequency (261~)
8 times	Inlet valve for bleach turns on.	Water level frequency (261~)
9 times	Tumble counter clockwise.	rpm (40~50)
10 times	Turn on the heater	Displayed 0XX
11 times	Drain Pump turns on	Water level frequency (261~)
12 times	Turn on Circulation Pump	Displayed 0XX
13 times	Turns on all lamps.	Displayed EU XX and LE XX alternately
14 times	Button Checks.	Displayed EU XX and LE XX alternately
15 times	High Speed Spin	rpm(1000)
16 times	1P:-- PDA Signal Check	1P:-- this function is not applied in this machine
17 times		L9C1

Note

- Make sure the drum is empty when a diagnostic test is performed. Do not use **L9C2**.

2 Factory reset - EEPT











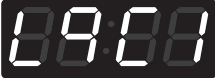

After factory reset, machine information is changed to the default value.

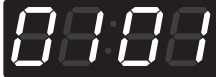
	Button	Display
Entering set up mode. You will see LqC1 	Press the NORMAL 75 or the NORMAL 60 Button until  appears in the display.	
	Press the START button.	
	Press the NORMAL 75 button until  appears in the display.	
	Press the START button, then factory reset is done.  is displayed.	
	1. Continue to set up the next mode. 2. Stop the change of setup value and go back to ready mode. • Noncoin type – Press MEDICAL 90 button until ready mode appears in the display.	

Note

- Washing time **10 minutes**
- Rinse cycle **twice**
- Top spin speed **1,000 RPM**
- Water level is HI(23.7Kh)

3 Time set up

	Button	Display
<p>Entering set up mode. You will see LqC1</p> 	<p>Press the NORMAL 75 or the NORMAL 60 button until  appears in the display.</p>	
	<p>Press the START button. The display will cycle through 2000 --> 0101 --> Sat --> 0000 repeatedly.</p>	
	<p>Press the START button.</p>	
	<p>Press the NORMAL 75 or the NORMAL 60 button to select year between 2000 and 2099.</p>	
	<p>Press the START button. The machine sets up the year, then advances to the next process automatically.</p>	
	<p>Press the NORMAL 75 or the NORMAL 60 button to select a month between 01 and 12.</p>	
	<p>Press the START button. The machine sets up the month, then advances to the next process automatically.</p>	
	<p>Press the NORMAL 75 or the NORMAL 60 button to select the day between 01 and 31.</p>	
	<p>Press the START button. The machine sets up the day, then advances to the next process automatically.</p>	
	<p>Press the NORMAL 75 or the NORMAL 60 button to select the hour between 00 and 23.</p>	
	<p>Press the START button. The machine sets up the hour, then advances to the next process automatically.</p>	
	<p>Press the NORMAL 75 or the NORMAL 60 button to select minute between 00 and 59.</p>	
	<p>Press the START button. The machine sets up the minute.</p>	
<p>1. Continue to set up the next mode. 2. Stop the change of setup value and go back to ready mode. • Noncoin type – Press MEDICAL 90 button until ready mode appears in the display.</p>		

4 Cycle Kill

■ Noncoin TYPE









Press **MEDICAL 90** button with **NORMAL 60** button, then press **NORMAL 75** button 3 times, press **START** button.

You will see



Button	Display
Press the NORMAL 75 or the NORMAL 60 button until Fill appears in the display.	
Press the START button.	
Press the NORMAL 75 button until 00:07 appears in the display.	
Press the START button. Start drain and display spin time.	Display spin time
End drain and display End with beeping.	
Go back to ready mode.	

■ Meaning of Error Codes that LED displays during occurrence of problem.

Problem	Possible Cause	Solution
	<ul style="list-style-type: none"> • Water supply is not adequate in area. • Water supply taps are not completely open. • Water inlet hose is bent. • The filter of the inlet hose clogged. 	<p>Check another tap in the house.</p> <p>Fully open tap.</p> <p>Straighten hose.</p> <p>Check the filter of the inlet hose.</p>
	<ul style="list-style-type: none"> • Drain hose is bent or clogged. • The drain filter is clogged. 	<p>Clean and straighten the drain hose.</p> <p>Clean the drain filter.</p>
	<ul style="list-style-type: none"> • Load is too small. • Load is out of balance. • The appliance has an imbalance detection and correction system. If individual heavy articles are loaded (bath mat, bath robe, etc.) and the imbalance is too great, after several attempts to restart the spin cycle the machine will stop and the error code will be displayed. 	<p>Add 1 or 2 similar items to help balance the load.</p> <p>Rearrange load to allow proper spinning.</p>
	<ul style="list-style-type: none"> • Is the door opened or not completely closed? 	<p>Close the door completely.</p> <p>* If it will not open, call for service.</p>
	<ul style="list-style-type: none"> • The water overfills due to a faulty water valve. 	<p>Close the water tap.</p> <p>Unplug the power plug.</p> <p>Call for service.</p>
	<ul style="list-style-type: none"> • The water level sensor malfunction. 	
	<ul style="list-style-type: none"> • Overload in motor. 	<p>Restart the cycle after 30 minutes. If LE is not released, call for service.</p>
	<ul style="list-style-type: none"> • The THERMISTOR is out order. 	<p>Unplug the power plug and call for service.</p>

Part 7

POWER FAIL RECOVERY

In case of power failure, the machine stops running but the time display remains on, showing the time just before power failure.

Part 8

DEFAULT WASHER SETTINGS

Default Settings	Default
Wash Time (Minutes)	10 Minutes
Rinse Time (Minutes)	16 Minutes
Spin Time (Minutes)	13 Minutes
Rinsing times	Twice
Water Level	HI
Top Spin speed	1000 rpm

MEMO

MEMO

MEMO

