



LG Customer Information Center

8-800-200-7676	Россия
0-800-303-000	Украина
8-8000-805-805	Казахстан
2255	Казахстан с мобильного GSM
8-820-0071-1111	Беларусь
8-0003-271	Латвия
8-800-30-800	Литва
800-9990	Эстония
800-0071-0005	Узбекистан & Кыргызстан

Register your product Online!

www.lg.com



BZ03





ENGLISH

РУССКИЙ

УКРАЇНСЬКА

ҚАЗАҚ

OWNER'S MANUAL

REFRIGERATOR- FREEZER

Please read this manual carefully before operating your set and retain it for future reference.

CONTENT

NAME OF PARTS	4
MOVEMENT & TRANSPORTATION.....	5
EARTH CONNECTION	5
INSTALLATION	6
PLEASE FAMILIARISE WITH THE FOLLOWING PARTS.....	7
TEMPERATURE CONTROL.....	8
METHODS OF MAKING ICE	8
BEST WAYS TO STORE FOOD.....	9
WAYS TO DISASSEMBLE SPARE PARTS.....	10
DEODORISATION.....	12
FRUIT & VEGETABLE COMPARTMENT.....	12
CLEANING THE REFRIGERATOR	13
TO REVERSE THE DOORS (OPTION)	14
SAFETY GUARDS.....	16
DOES THE REFRIGERATOR HAVE A MALFUNCTION.....	18
THIS IS NOT A MALFUNCTION.....	19
DISPOSAL OF YOUR OLD APPLIANCE	20

NAME OF PARTS

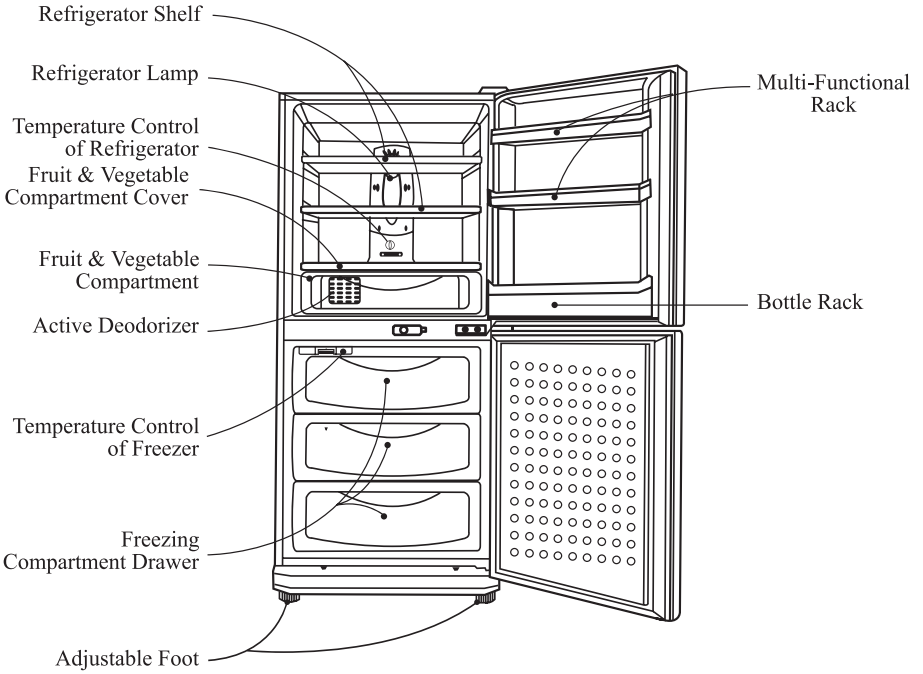

Note

If you find some parts missing from your unit, they may be parts only used in other models.

MOVEMENT & TRANSPORTATION

● BEFORE TRANSPORTATION

- 1.Remove all the food from the refrigerator, secure the spare parts such as the shelves by adhesive tape.
- 2.Fasten the adjustable foot to the ◀ direction.

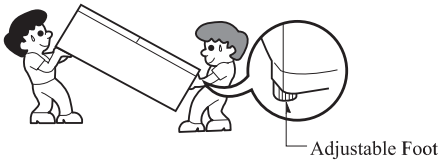

● DURING TRANSPORTATION

1. Hold tightly the adjustable foot at the bottom of the refrigerator and the upper handle at the back.
2. During transportation, please note that the refrigerator should not be tilted.
3. When transporting to a more distant place, the refrigerator should be placed vertically on the vehicle. (Otherwise problem will exist)

Note:Please fasten the adjustable foot to the ◀ direction before transportation, otherwise the floor will be scraped or the foot will be blocked from moving.

EARTH CONNECTION

- Note: 1.The earth wire of this electrical appliance has been connected to the power plug ,please do not change the power plug on your own.
- 2.Plug your refrigerator into a standard 220-240V household outlet,make sure the socket is properly earthed.
 - 3.If you receive an electrical shock by touching any part of the refrigerator,you should stop using the refrigerator immediately and contact the specified maintenance service unit or the retail shop of this product at once.

ACCESSIBILITY OF SUPPLY PLUG

The refrigerator-freezer should be so positioned that the supply plug is accessible for quick disconnection when accident happens.

POWER CORD REPLACEMENT

If the supply cord is damaged,it must be replaced by a special cord or assembly from the manufacturer or its service agent.

INSTALLATION

Installing on a firm and flat surface

- Unstable installation is the main reason of vibration and noise.
- When the refrigerator is installed unstably, it can be stabilised by adjusting the adjustable foot.
- Slightly rising the front part of the refrigerator allow you to close the door very easily.
- When installed on a carpet or floor, please put a firm mat under the refrigerator otherwise the bottom part will change colour.

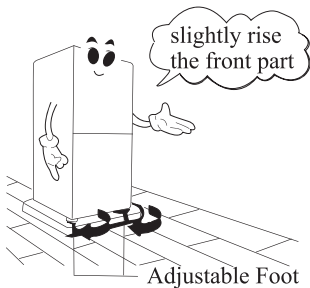

Keep an appropriate distance between the wall

- To ensure proper air circulation around the fridge-freezer, please maintain sufficient space on both the sides as well as top and maintain at least 2 inches (5 cm) from the rear wall.
- Too small a distance from adjust items may result in lowered freezing capability and increased electricity charges consumption.

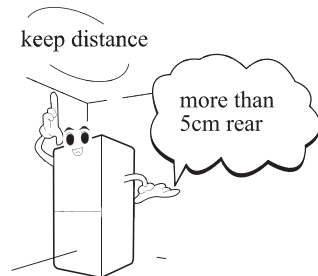

Installing in a less humid environment

- Do not install the refrigerator in a humid place or where water can easily be splashed.
- If the refrigerator is installed in a humid environment, it will go moldy. This will lower insulation property and cause electricity leakage.

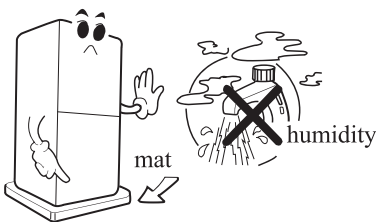

Avoid installing near heat and gas

- High temperature will lower the refrigeration and increase the power consumption.
- Installing near gas or smoke will change the surface colour of the refrigerator.

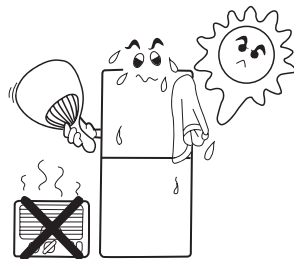

PLEASE FAMILARISE WITH THE FOLLOWING PARTS

**Refrigerator
Compartment Shelf**

- Food containing a high water content will freeze if stored in the inner part of the refrigerator due to low temperature.

**Refrigerator
Compartment Cooling
Air Inlet**

- Cooling air is evenly blown from the inlet into the refrigerator compartment.

**Fruit & Vegetable
Compartment**

- To store vegetable and fruits etc.

**Refrigerator
Compartment Cooling
Air Suction Inlet**

- Please do not block this inlet as it will restrict the circulation of the cooling air flow.

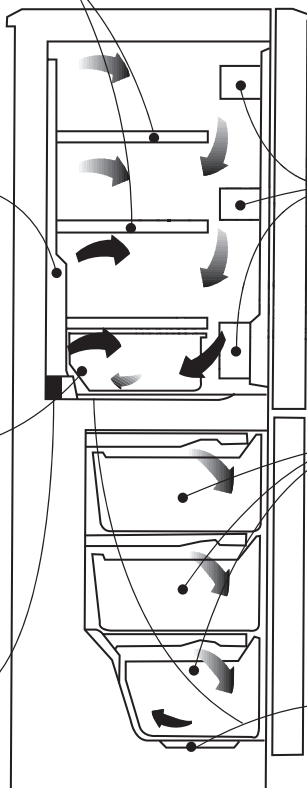

**Refrigerator
Compartment
Door Rack**

- For the storage of small size foods and bottles.

**Freezing
Compartment
Drawer**

- Please install it according to the size of frozen food.





**Note:(Cooling Air
Suction Inlet)**

- Please do not take away the freezing compartment drawer or the refrigerating fruit and vegetable compartment, otherwise the operation of refrigerator will be affected.

TEMPERATURE CONTROL

Please set the temperature on normal position when normal operation.

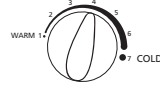
Note: Please set the temperature only in the range of “1 ●●● 2 ●●●●● 7”. On other position, it will affect the storage of food.

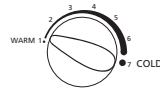
MODE	FREEZING COMPARTMENT	REFRIGERATING COMPARTMENT	
Cold	For larger storage of food  COLD	 Position: 6-7	For larger storage of food or insufficient cooling air in the refrigerating compartment
Normal	For normal operation  NORMAL	 Position: 3-5	For operation
Warm	For small storage of food  WARM	 Position: 1-2	For small storage of food or sufficient cooling air in the refrigerating compartment

METHODS OF MAKING ICE

Making Ice Pour water into the ice cube maker, and then store the maker in the freezing compartment drawer.

Removing ice Grasp both sides of the ice cube maker, twist once according to the picture and the ice can be removed. Soak the ice maker in the water for a while, it will be easier to remove the ice.

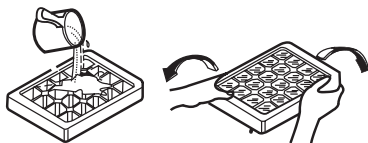

BEST WAYS TO STORE FOOD

Storing the food

- **Store foods which are easily frozen on the outer part of the refrigerator shelf.**

- If foods which are easily frozen or contain a high water content are stored on the inner part of the refrigerator shelf, it will be frozen due to low temperature.

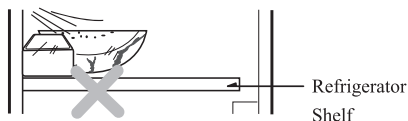

- **Store the food or other things after cleaning and wiping.**

- Store vegetables and fruits after cleaning and wiping. Packed food like bottles should be stored after wiping to avoid polluting the other foods.



- **Storing heated food after cooling.**

- Storing the heated food directly in the refrigerator will affect the other foods inside and will also cause higher power consumption.

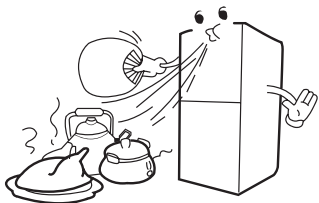

- **In the low temperature mode, do not store the food which can easily be rotten for a long time.**

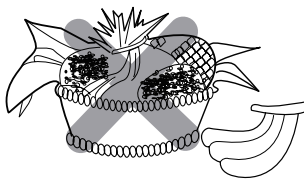

- **Store the food after packing or putting into tight container.**

- Packing the food before storing can prevent drying. This can also reduce odour when storing the food for a longer time.

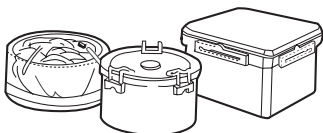

- **Do not store bottles in the Freezing Compartment.**

- If bottles are stored in the Freezing compartment, the liquid inside will be frozen and break the bottle.
- The volume of liquid such as juice or water should not exceed 80% of the container's volume.



WAYS TO DISASSEMBLE SPARE PARTS

Refrigerator Shelf

- Slightly rise the front part of the shelf, then pull outward.

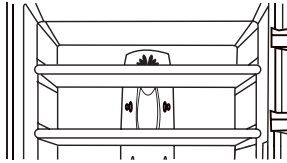

Fruit & Vegetable Compartment

- Fruit & Vegetable Compartment-pull outward.
- Fruit & Vegetable Cover-pull the fruit & vegetable compartment first, lift upward and pull outward.

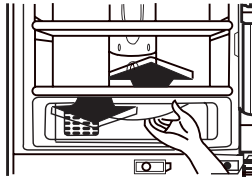

Refrigerator Lamp

Pull out the power plug before removing

- Light Cover---insert the screwdriver into the groove on the top and then slightly pull the cover out.
- Light Bulb-screw out the bulb according to the direction shown in the picture.
- Refrigerator lamp is 240V/15W especially for refrigerator.

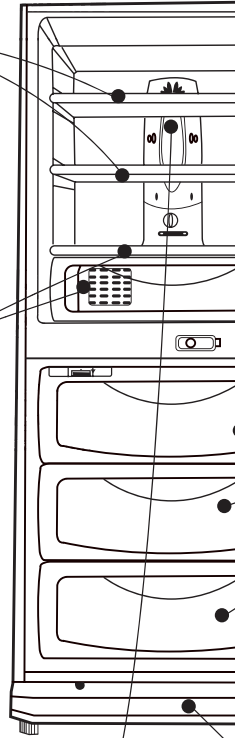
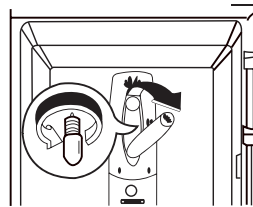

WAYS TO DISASSEMBLE SPARE PARTS

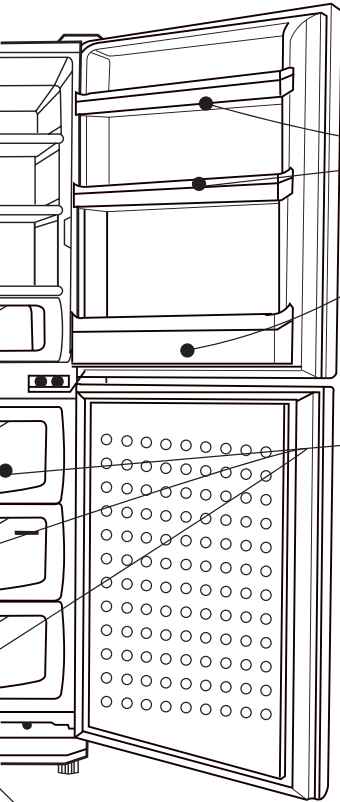

Refrigerating Compartment Door Rack

- Grasp both sides, lift upward and then pull outward.

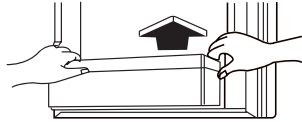

Freezing Compartment Drawer

- Pull outward. Rise it slightly and then take it out.

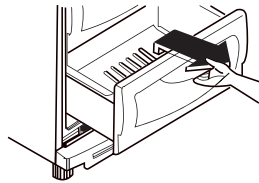

Bottom Cover

- Remove the two screws which hold the bottom Cover, grasp both sides and then pull outward.

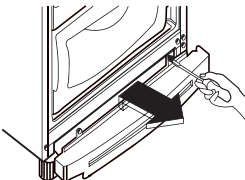

◆ Evaporating Pan

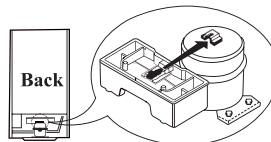

- Grasp the defrosting basin and slightly press downward while pulling outward.
- Installation: Note the direction of the arrow in the picture, push the pan into the hole on top of the compressor until you hear a click, then the basin is installed properly.

DEODORISATION

FEATURE

When the Active Deodorizer is used.

- Remove odour inside the refrigerator without producing any harmful effect to the food.

HOW TO USE IT?

- Active deodorizer is installed at the cooling air suction inlet of the refrigerator compartment.
- Please do not puncture the suction inlet by sharp solid.(otherwise the active deodorizer will be damaged)
- Please pack the strong smelling foods or store them in a tight container to avoid odour.

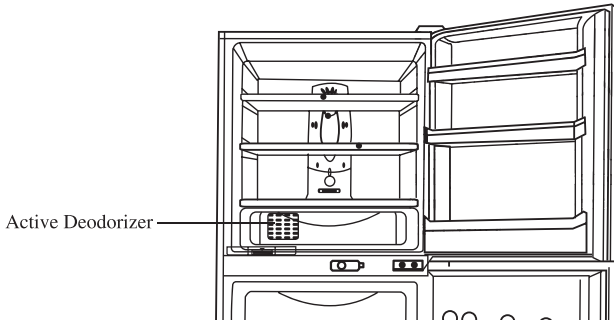

FRUIT & VEGETABLE COMPARTMENT

For storing fresh fruit and vegetables.

When using the Fruit & Vegetable Compartment

- If there is any water in the compartment, the food will rot. Therefore please remove water before storing the food.
- At the bottom of the refrigerator compartment (i.e. the bottom part of fruit & vegetable compartment) is the cooling air suction inlet. You must not take out the fruit & vegetable compartment and put the food directly on the bottom part. Otherwise the operation of refrigerator will be affected.

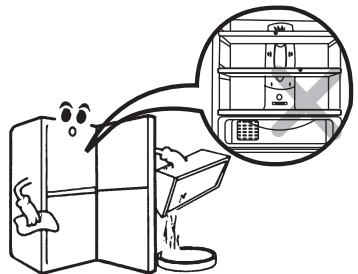

CLEANING THE REFRIGERATOR

● Before cleaning

- Unplug the refrigerator first to ensure safety.



● Shelf and door rack

- Places are easily made dirty by food. The inside of the refrigerator must be kept clean.



● Cooling air suction inlet in the refrigerating and freezing compartment.

- Please do not stick other things on the inlet during cleaning.



● Do not shower the refrigerator with water

- This may cause an electrical shock.

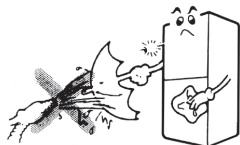

● After cleaning please check whether:

1. The wire is damaged.
2. The power plug is not overheating.
3. The power plug is inserted properly.



● Surface of refrigerator

- Clean it with a soft cloth using a soapy cleanser, then dry with a clean cloth.

neutral detergent



● Magnetic door seal

- If the door seal is dirty or covered in juice for a long time, the effectiveness of magnetic door seal will be reduced.
- Regular cleaning is necessary.



● Fruit & Vegetable Compartment

- A place that will easily store water. Too much water will rot the food, therefore the compartment should be taken out and cleaned regularly.



● Please do not clean the refrigerator with the following things:

- Cleaning powder, petrol benzene, salt, acid, boiling water and brush etc. as they will damage the surface of refrigerator. Therefore please do not use them.



TO REVERSE THE DOORS (OPTION)

Your fridge-freezer maybe designed with reversible doors,so that they may open from either the left of right hand side to suit your kitchen design.

Precaution

- 1.Before reversing the door,first of all,you should take out food and accessories like shelves or trays which are not fixed the fridge-freezer.
- 2.Use Torque Wrench or Spanner to fix or remove the bolt.
- 3.Do not lay the fridge-freezer down. This will cause problem.
- 4.Be careful not to drop the doors in disassembling or assembling.
- 5.To avoid the two doors dropping and result in physical injure,at least two persons are require to change the door opening type.

How to Reverse the Doors

First please operate as the following steps (Figure A):

- 1.Disassemble the Cover Hinge and Hinge Upper right(1);
- 2.Remove the Refrigerator Door(2). Disassemble the Hinge Middle (4) and remove the Freezer Door(3);
- 3.Remove the Cap on the left and install it on the corresponding position(6);
- 4.Remove Cover Assembly Lower(11). Disassemble Cap Cover and assemble the spare Cap Cover on the right side(12);
- 5.Hinge Lower Right and hinge lower left change position(5). Assemble cover assembly lower(11).
- 6.Remove the right limit on the Refrigerator Door and the Freezer Door(10). Take out the spare left limit from the bag with user manual included and install it on the left of the Refrigerator Door and the Freezer Door.
- 7.Install the freezer door(7). Fix the Hinge Middle on the left side(9). Then install the Refrigerator Door (8);
- 8.Take out the spare Hinge Upper Left and Cover Hinge Left from the bag with user manual included and install it on Hinge Upper Left(14).

Then please operate as the following steps (Figure B):

- 9.Remove the caps (1) (3) on the handle of the Refrigerator Door and the Freezer Door, disassemble the handles;
- 10.Remove the caps on the Refrigerator Door and the Freezer Door right,then install them on the corresponding locations(5)(6);
- 11.Fix the handles on the others side(7), then install the caps (1)(3);
- 12.For a refrigerator with a vertical handle, please replace the handle to the opposite position.

Note

Reversing the doors is not covered by the warranty.

TO REVERSE THE DOORS (OPTION)

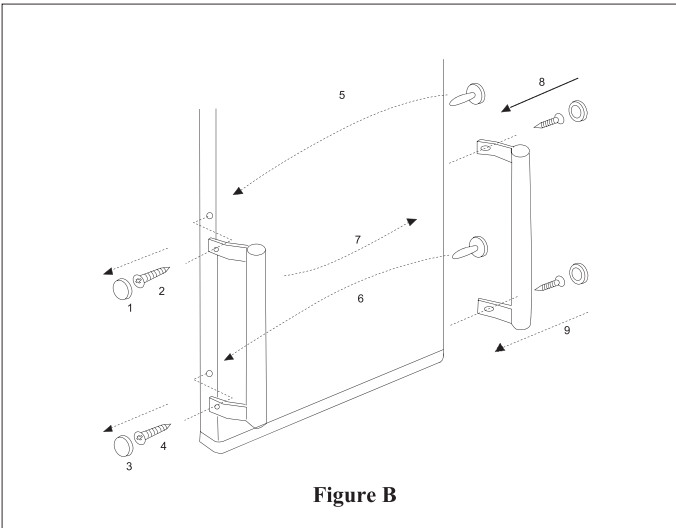
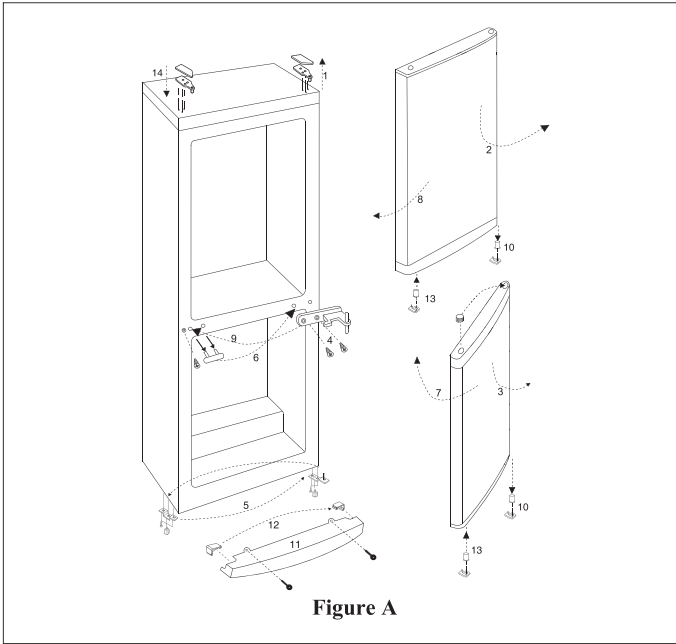

SAFETY GUARDS

- **Please use the exclusive power socket.**
 - If the refrigerator uses the same power socket as other electrical appliances, the socket could be overloaded abnormally and fire may be resulted, which may cause a fire.



- **Please note that the back of the refrigerator should not touch the power plug.**
 - Power plug could be easily damaged and this may cause fire or electric shock.

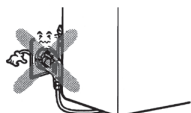

- **Please unplug the refrigerator first before cleaning. Do not do this with wet hands.**
 - This may probably cause electric shock.

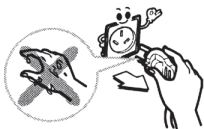

- **Please do not store flammable things like ether, benzene, alcohol and liquefied oxygen in the refrigerator.**
 - This may cause explosion.



- **Please unplug the refrigerator before changing the light bulb.**
 - Otherwise this may cause an electric shock.



- **Please do not put heavy things on top of the refrigerator.**
 - When you open the door, the heavy things could easily fall down and hurt you.



- **Please do not climb on the door.**
 - The refrigerator could be turned over and hurt small children.

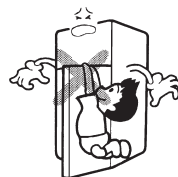

- **Please do not store medicine or academic information in the refrigerator.**
 - Things which require strict temperature control should not be stored in the refrigerator, otherwise they will go bad or produce accidental effects.



SAFETY GUARDS

- **Please keep away from fire.**

- Can cause fire.

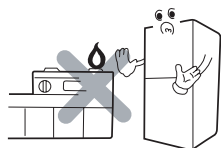

- **In case of a gas leak, please do not touch the refrigerator and the power socket, you should open the windows and the door for ventilation.**

- As a spark may cause an explosion and lead to fire.



- **Please do not place water container such as vases, glasses, cosmetic or medicine on top of the refrigerator.**

- Liquid spilt over the refrigerator will reduce the insulation effect, and may cause an electric shock or fire.



- **Please do not store bottles in the freezing compartment.**

- As bottles in the freezing compartment, liquid inside will be frozen and the bottle will break.



- **Please do not install in a humid place or where water can easily be splashed.**

- This will reduce the insulation effect and may cause an electric shock.

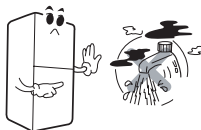

- **Please unplug the refrigerator if it is not to be used for a long time.**

- Reduced insulation may cause an electric shock or fire.



- **During transportation, please hold the adjustable feet at the bottom of the refrigerator and the upper handle at the back.**

- Otherwise, the refrigerator may fall down.

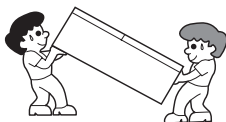

- **When the refrigerator is unplugged, please wait for five minutes before you plug it again.**

- Otherwise the compressor will be overloaded.

after 5 minutes

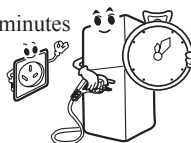





⚠ CAUTION

This appliance is not intended for use by persons (including children) with reduced physical, sensory or mental capabilities, or lack of experience and knowledge, unless they have been given supervision or instruction concerning use of the appliance by a person responsible for their safety. Children should be supervised to ensure that they do not play with the appliance.

DOES THE REFRIGERATOR HAVE A MALFUNCTION?

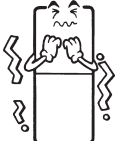
If the refrigerator still does not work properly after checking the following tasks, please unplug the refrigerator and immediately contact the specified maintenance service unit or the retail shop of this product.

Situation	Please check
<p>The refrigerator does not operate</p> 	<ul style="list-style-type: none"> ➡ Is there a power failure? ➡ Is it 220V-240V?
<p>Inefficient cooling</p> 	<ul style="list-style-type: none"> ➡ Is the temperature control in the refrigerator compartment turned to "too low" mode? ➡ Is there any direct sunshine or heaters near by? ➡ Have you put some heated goods directly into the refrigerator? ➡ Have you stored too much food? ➡ Have you frequently opened the door of the refrigerator? ➡ Is the door closed properly? ➡ Have you kept an appropriate distance between the refrigerator and the wall? ➡ Is there any blockage in the air suction inlets of the refrigerator and freezing compartment?
<p>Food stored in the refrigerator compartment becomes frozen</p> 	<ul style="list-style-type: none"> ➡ Is the temperature control in the refrigerator compartment turned to "too high" mode? ➡ Have you stored moist food that can easily be frozen in front of the cooling air inlet in the shelf?
<p>Too much noise, abnormal sound</p> 	<ul style="list-style-type: none"> ➡ Is it the normal sound when the refrigerator starts to work or turn off the power? ➡ Installed on an unstable ground. Adjust feet to stabilise. ➡ Is the back of refrigerator too close to the wall? ➡ Is there anything fallen down near the refrigerator? ➡ Is there any other things placed on top of the refrigerator?

THIS IS NOT A MALFUNCTION

● The refrigerator dew forming on the surface.

- If the refrigerator is installed in a humid environment or if it is raining, there can be dew forming on the surface of the refrigerator. This is because moisture in the air touches the surface of the refrigerator.
- Please wipe it with a clean soft cloth.

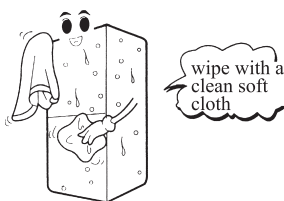

● You hear a sound like flowing water.

- It is the sound produced when the compressor stops operating.
- It is the sound of flowing refrigerant in the cooling equipment.
- Sound can be produced by the contraction and expansion of the parts due to temperature changes inside the refrigerator.

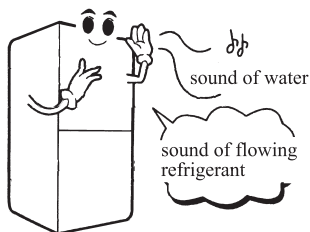

● The surface of refrigerator is warm.

- A high temperature pipe which prevents dewing is installed inside the refrigerator. When the refrigerator begins to operate or when it is summer, the surface will become warm. Please do not worry because this is a normal effect.

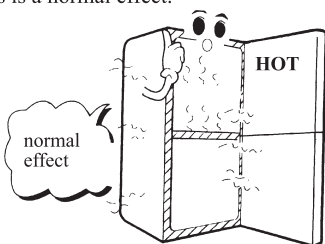

● The inner part of refrigerator compartment has dew forming.

- This is because the refrigerator is installed in a humid environment or the door is opened too long.
- Foods with a high water content are not packed well before storing.

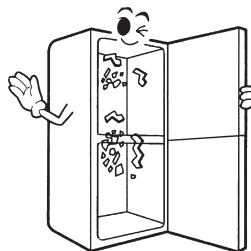

DISPOSAL OF YOUR OLD APPLIANCE



Disposal of your old appliance

1. When this crossed-out wheeled bin symbol is attached to a product it means the product is covered by the European Directive 2002/96/EC.
2. All electrical and electronic products should be disposed of separately from the municipal waste stream via designated collection facilities appointed by the government or the local authorities.
3. The correct disposal of your old appliance will help prevent potential negative consequences for the environment and human health.
4. For more detailed information about disposal of your old appliance, please contact your city office, waste disposal service or the shop where you purchased the product.

- Information of fluorinated greenhouse gases used as refrigerant of this refrigerator.

Chemical name	Composition of Gases	Total GWP (kg CO ₂ -eq)
R-134a	100% HFC-134a	1300