



LG

Life's Good

ENGLISH

INSTALLATION MANUAL

AIR CONDITIONER

- Please read this installation manual completely before installing the product.
- Installation work must be performed in accordance with the national wiring standards by authorized personnel only.
- Please retain this installation manual for future reference after reading it thoroughly.

TYPE : WALL MOUNTED

TABLE OF CONTENTS

Installation Requirements	Required Parts	Required Tools
Safety Precautions3	<input type="checkbox"/> Four type "A" screws & plastic anchors	<input type="checkbox"/> Level gauge
Introduction6	<input type="checkbox"/> Connecting cable	<input type="checkbox"/> Screw driver
Symbols used in this manual.....6	<input type="checkbox"/> Installation guide map	<input type="checkbox"/> Electric drill
Features6		<input type="checkbox"/> Hole core drill(ø70mm)
Installation7	<input type="checkbox"/> Pipes: Gas side	<input type="checkbox"/> Flaring tool set
Installation parts.....7	Liquid side	<input type="checkbox"/> Specified torque wrenches 1.8kg.m, 4.2kg.m, 5.5kg.m, 6.6kg.m (different depending on model No.)
Installation tools7	<input type="checkbox"/> Insulation materials	<input type="checkbox"/> SpannerHalf union
Installation map.....8	<input type="checkbox"/> Additional drain pipe (Outer diameter15.5mm)	<input type="checkbox"/> A glass of water
Selecting the best location9	<input type="checkbox"/> Two type "B" screws	<input type="checkbox"/> Screw driver
Piping length and elevation.....10		<input type="checkbox"/> Hexagonal wrench(4mm)
Fixing installation plate.....11		<input type="checkbox"/> Gas-leak detector
Drilling a hole in the wall11		<input type="checkbox"/> Vacuum pump
Flaring work12		<input type="checkbox"/> Gauge manifold
Connecting the piping13		<input type="checkbox"/> Owner's manual
Connecting the cables19		<input type="checkbox"/> Thermometer
Checking the drainage21		<input type="checkbox"/> Remote control holder
Forming the piping.....22		
Air purging.....23		
Test running25		
Installation guide at the seaside27		
Selecting the location (Outdoor Unit).....27		

Safety Precautions



To prevent the injury of the user or other people and property damage, the following instructions must be followed.

- Be sure to read before installing the air conditioner.
- Be sure to observe the cautions specified here as they include important items related to safety.
- Incorrect operation due to ignoring instruction will cause harm or damage. The seriousness is classified by the following indications.

⚠ WARNING This symbol indicates the possibility of death or serious injury.

⚠ CAUTION This symbol indicates the possibility of injury or damage to properties only.

- The meanings of the symbols used in this manual are as shown below.

	Be sure not to do.
	Be sure to follow the instruction.

⚠ WARNING

■ Installation

Always perform grounding.

- Otherwise, it may cause electrical shock.

Don't use a power cord, a plug or a loose socket which is damaged.

- Otherwise, it may cause a fire or electrical shock.

For installation of the product, always contact the service center or a professional installation agency.

- Otherwise, it may cause a fire, electrical shock, explosion or injury.

Securely attach the electrical part cover to the indoor unit and the service panel to the outdoor unit.

- If the electrical part cover of the indoor unit and the service panel of the outdoor unit are not attached securely, it could result in a fire or electric shock due to dust, water, etc.

Always install an air leakage breaker and a dedicated switching board.

- No installation may cause a fire and electrical shock.

Do not keep or use flammable gases or combustibles near the air conditioner.

- Otherwise, it may cause a fire or the failure of product.

Ensure that an installation frame of the outdoor unit is not damaged due to use for a long time.

- It may cause injury or an accident.

Do not disassemble or repair the product randomly.

- It will cause a fire or electrical shock.

Do not install the product at a place that there is concern of falling down.

- Otherwise, it may result in personal injury.

Use caution when unpacking and installing.

- Sharp edges may cause injury.

■ Operation

Do not share the outlet with other appliances.

- It will cause an electric shock or a fire due to heat generation.

Do not use the damaged power cord.

- Otherwise, it may cause a fire or electrical shock.

Do not modify or extend the power cord randomly.

- Otherwise, it may cause a fire or electrical shock.

Take care so that the power cord may not be pulled during operation.

- Otherwise, it may cause a fire or electrical shock.

Unplug the unit if strange sounds, smell, or smoke comes from it.

- Otherwise, it may cause electrical shock or a fire.

Keep the flames away.

- Otherwise, it may cause a fire.

Take the power plug out if necessary, holding the head of the plug and do not touch it with wet hands.

- Otherwise, it may cause a fire or electrical shock.

Do not use the power cord near the heating tools.

- Otherwise, it may cause a fire and electrical shock.

Do not open the suction inlet of the indoor/outdoor unit during operation.

- Otherwise, it may electrical shock and failure.

Do not allow water to run into electrical parts.

- Otherwise, it may cause the failure of machine or electrical shock.

Hold the plug by the head when taking it out.

- It may cause electric shock and damage.

Never touch the metal parts of the unit when removing the filter.

- They are sharp and may cause injury.

Do not step on the indoor/outdoor unit and do not put anything on it.

- It may cause an injury through dropping of the unit or falling down.

Do not place a heavy object on the power cord.

- Otherwise, it may cause a fire or electrical shock.

When the product is submerged into water, always contact the service center.

- Otherwise, it may cause a fire or electrical shock.

Take care so that children may not step on the outdoor unit.

- Otherwise, children may be seriously injured due to falling down.

 **CAUTION****■ Installation**

Install the drain hose to ensure that drain can be securely done.

- Otherwise, it may cause water leakage.

Always inspect gas leakage after the installation and repair of product.

- Otherwise, it may cause the failure of product.

Install the product so that the noise or hot wind from the outdoor unit may not cause any damage to the neighbors.

- Otherwise, it may cause dispute with the neighbors.

Keep level parallel in installing the product.

- Otherwise, it may cause vibration or water leakage.

■ Operation

Avoid excessive cooling and perform ventilation sometimes.

- Otherwise, it may do harm to your health.

Do not use an appliance for special purposes such as preserving animals vegetables, precision machine, or art articles.

- Otherwise, it may damage your properties.

Use a soft cloth to clean. Do not use wax, thinner, or a strong detergent.

- The appearance of the air conditioner may deteriorate, change color, or develop surface flaws.

Do not place obstacles around the flow inlet or outlet.

- Otherwise, it may cause the failure of appliance or an accident.

Introduction

Symbols used in this Manual



This symbol alerts you to the risk of electric shock.



This symbol alerts you to hazards that may cause harm to the air conditioner.

NOTICE

This symbol indicates special notes.



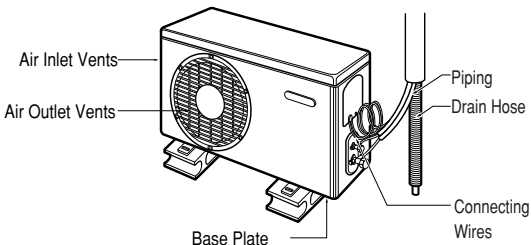
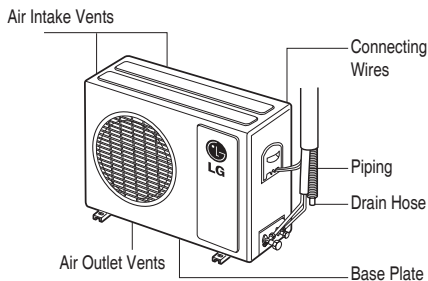
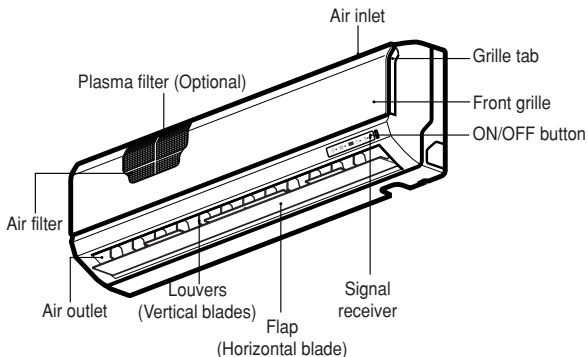



Features



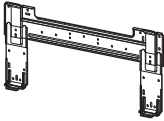
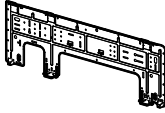







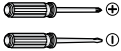

Installation

Read carefully, and then follow step by step.

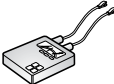
Installation Parts

Type 1	Type 2
Installation plate	Installation plate
	
Type "B" screw	Type "B" screw
	
Type "A" screw (6 EA)	Type "A" screw (8 EA)
	
Remote control holder	Remote control holder
	

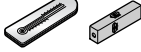
Installation Tools

Figure	Name	Figure	Name
	Screw driver		Ohmmeter
	Electric drill		Hexagonal wrench
	Measuring tape, Knife		Ammeter
	Hole core drill		Gas-leak detector
	Spanner		Thermometer, Horizontal meter
	Torque wrench		Flaring tool set

Installation Map

NOTICE

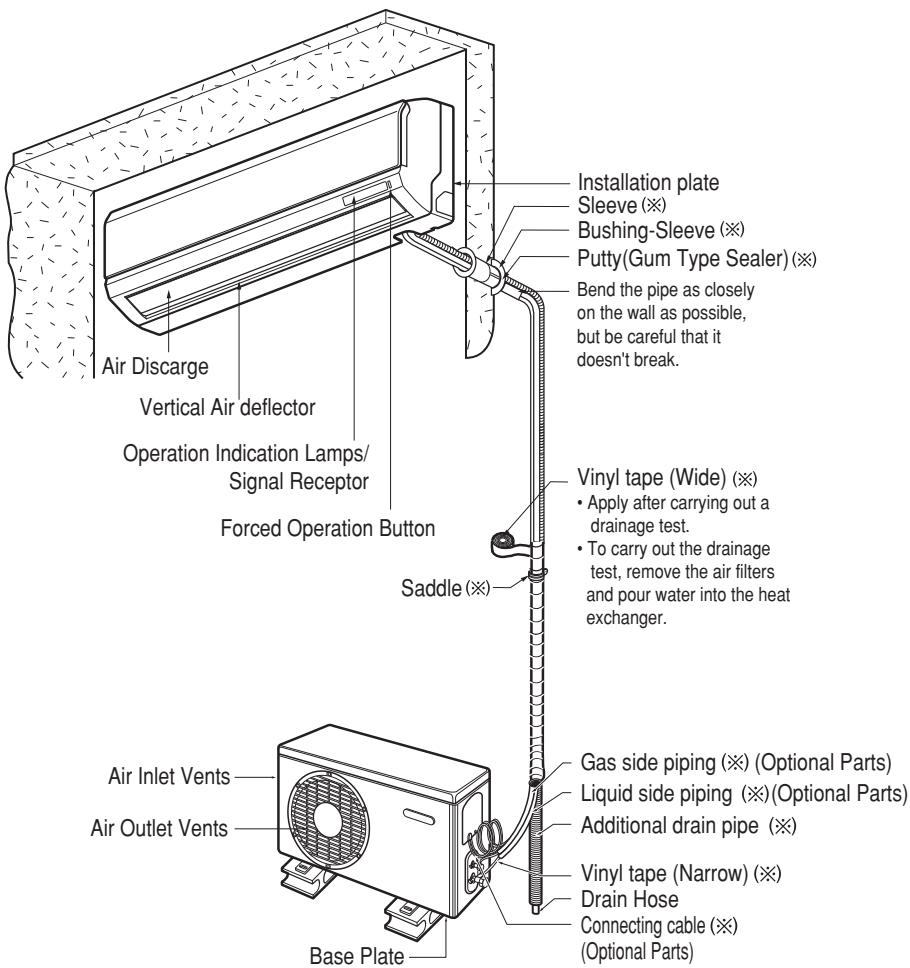

Installation parts you should purchase. (⊗)

Select the best Location

Indoor unit

1. Do not have any heat or steam near the unit.
2. Select a place where there are no obstacles in front of the unit.
3. Make sure that condensation drainage can be conveniently routed away.
4. Do not install near a doorway.
5. Ensure that the interval between a wall and the left (or right) of the unit is more than 100mm. The unit should be installed as high as possible on the wall, allowing a minimum of 200mm from ceiling.
6. Use a stud finder to locate studs to prevent unnecessary damage to the wall.

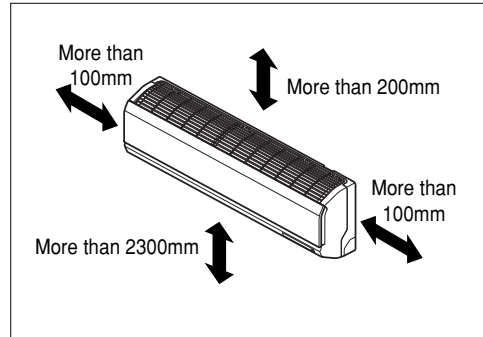

⚠ CAUTION

Install the indoor unit on the wall where the height from the floor is more than 2300mm.

Outdoor unit

1. If an awning is built over the unit to prevent direct sunlight or rain exposure, make sure that heat radiation from the condenser is not restricted.
2. Ensure that the space around the back and sides is more than 300mm. The front of the unit should have more than 700mm of space.
3. Do not place animals and plants in the path of the warm air.
4. Take the weight of the air conditioner into account and select a place where noise and vibration are minimum.
5. Select a place where the warm air and noise from the air conditioner do not disturb neighbors.

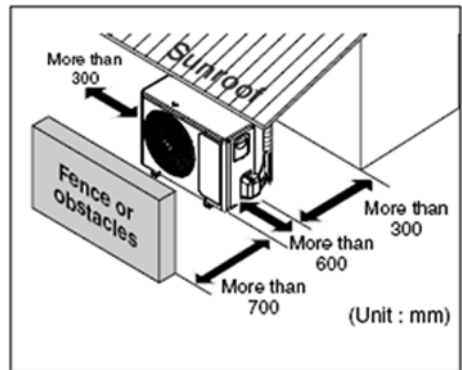

Piping Length and Elevation

Capacity (kW)	Pipe Size				Standard Length (m)	Max. Elevation ②(m)	Max. Length ①(m)	Additional Refrigerant (g/m)
	GAS(Ø)		LIQUID(Ø)					
	mm	inch	mm	inch				
2.5 (9kBtu/h) 3.5 (12kBtu/h)	9.52	3/8	6.35	1/4	7.5	7	15	20
5.3 (18kBtu/h)	12.7	1/2	6.35	1/4	7.5	15	20	20
7.3 (24kBtu/h)	15.88	5/8	9.52	3/8	7.5	15	30	35

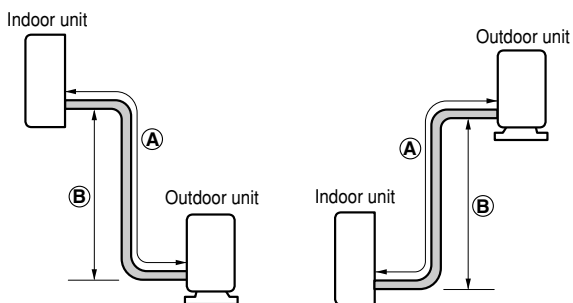

⚠ CAUTION

Capacity is based on standard length and maximum allowable length is on the basis of reliability. Additional refrigerant must be charged after 7.5m.

Fixing Installation Plate

The wall you select should be strong and solid enough to prevent vibration

1. Mount the installation plate on the wall with type "A" screws. If mounting the unit on a concrete wall, use anchor bolts.
 - Mount the installation plate horizontally by aligning the centerline using a level.
-
2. Measure the wall and mark the centerline. It is also important to use caution concerning the location of the installation plate—routing of the wiring to power outlets is through the walls typically. Drilling the hole through the wall for piping connections must be done safely.

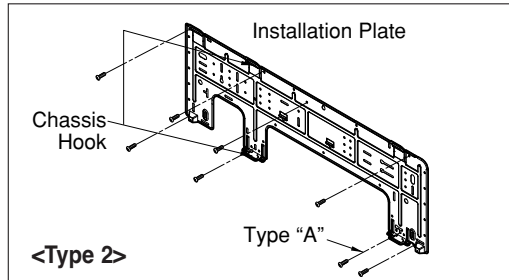
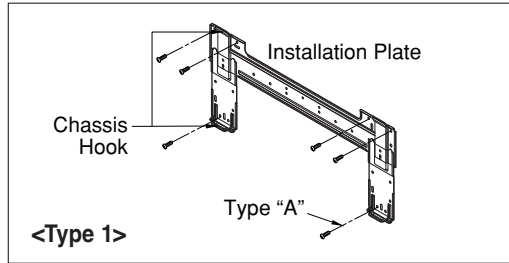

CHASSIS (Grade)	Distance (mm)			
	A	B	C	D
S4	55	105	65	105
SE	70	110	90	110
S5	100	122	240	122

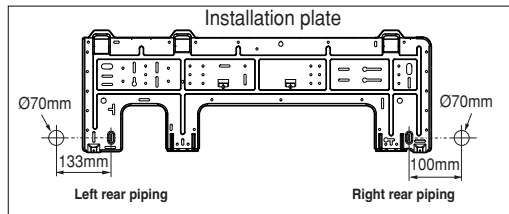
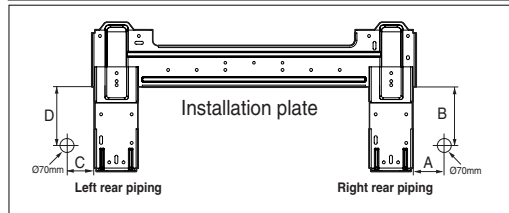

Drill a Hole in the Wall

- Drill the piping hole with a $\varnothing 70\text{mm}$ hole core drill. Drill the piping hole at either the right or the left with the hole slightly slanted to the outdoor side.

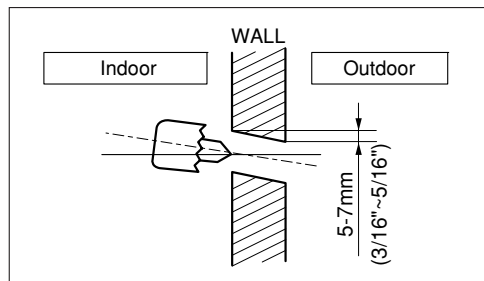

Flaring Work

Main cause for gas leakage is due to defect in flaring work. Carry out correct flaring work in the following procedure.

Cut the pipes and the cable.

1. Use the piping kit accessory or the pipes purchased locally.
2. Measure the distance between the indoor and the outdoor unit.
3. Cut the pipes a little longer than measured distance.
4. Cut the cable 1.5m longer than the pipe length.

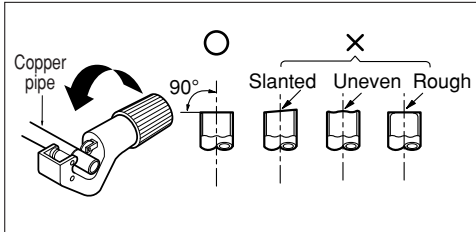

Burrs removal

1. Completely remove all burrs from the cut cross section of pipe/tube.
2. Put the end of the copper tube/pipe in a downward direction as you remove burrs in order to avoid dropping burrs into the tubing.

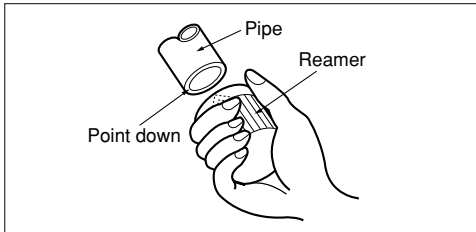

Putting nut on

- Remove flare nuts attached to indoor and outdoor unit, then put them on pipe/tube having completed burr removal.
(not possible to put them on after flaring work)

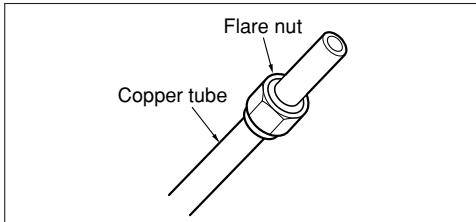

Flaring work

1. Firmly hold copper pipe in a die in the dimension shown in the table below.
2. Carry out flaring work with the flaring tool.

Outside diameter		A
mm	inch	mm
Ø6.35	1/4	1.1~1.3
Ø9.52	3/8	1.5~1.7
Ø12.7	1/2	1.6~1.8
Ø15.88	5/8	1.6~1.8
Ø19.05	3/4	1.9~2.1

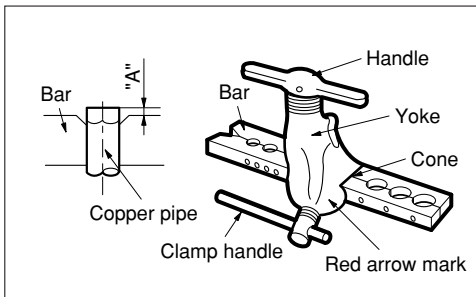

Check

1. Compare the flared work with the figure by.
2. If a flared section is defective, cut it off and do flaring work again.

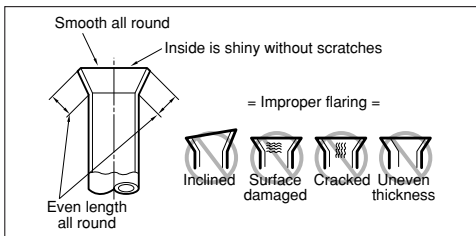

Connecting the Piping

Indoor Unit

1. Prepare the indoor unit's piping and drain hose for installation through the wall.
2. Remove the plastic tubing retainer(see the illustration by) and pull the tubing and drain hose away from chassis.
3. Replace only the plastic tubing holder 1, not the holder 2 in the original position.

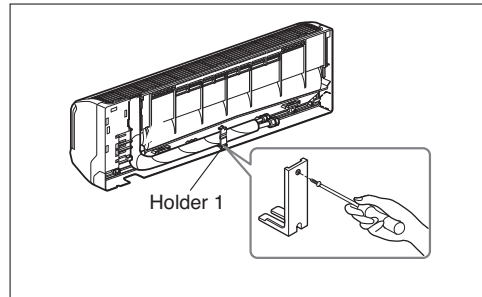

For right rear piping

1. Route the indoor tubing and the drain hose in the direction of rear right.
2. Insert the connecting cable into the indoor unit from the outdoor unit through the piping hole.
 - Do not connect the cable to the indoor unit.
 - Make a small loop with the cable for easy connection later.
3. Tape the tubing, drain hose, and the connecting cable. Be sure that the drain hose is located at the lowest side of the bundle. Locating at the upper side can cause drain pan to overflow inside the unit.

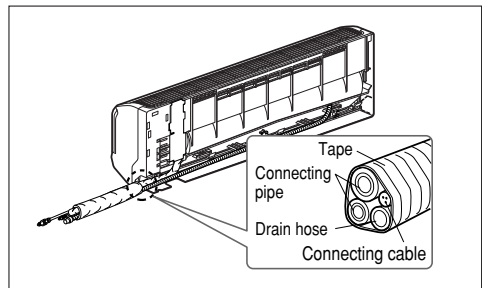
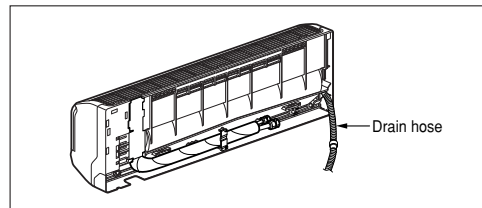

⚠ CAUTION

If the drain hose is routed inside the room, insulate the hose with an insulation material* so that dripping from "sweating"(condensation) will not damage furniture or floors.

*Foamed polyethylene or equivalent is recommended.

4. Indoor unit installation

Hook the indoor unit onto the upper portion of the installation plate. (Engage the two hooks of the rear top of the indoor unit with the upper edge of the installation plate.) Ensure that the hooks are properly seated on the installation plate by moving it left and right.

Press the lower left and right sides of the unit against the installation plate until the hooks engage into their slots (clicking sound).

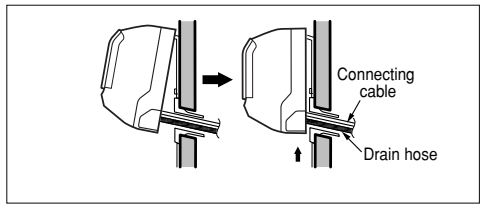

Connecting the piping to the indoor unit and drain hose to drain pipe.

1. Align the center of the pipes and sufficiently tighten the flare nut by hand.
2. Tighten the flare nut with a wrench.

Outside diameter		Torque
mm	inch	kgf·m
Ø6.35	1/4	1.8~2.5
Ø9.52	3/8	3.4~4.2
Ø12.7	1/2	5.5~6.6
Ø15.88	5/8	6.3~8.2
Ø19.05	3/4	9.9~12.1

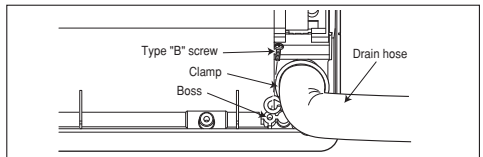
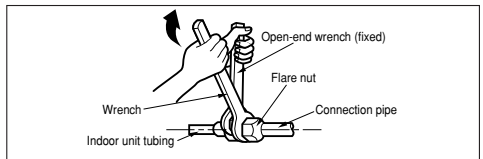
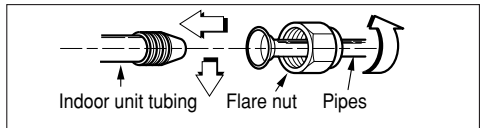

3. Mount the clamp on the boss with a type "B" screw. (optional)
4. When extending the drain hose at the indoor unit, install the drain pipe.

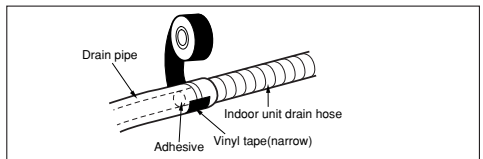

Wrap the insulation material around the connecting portion.

1. Overlap the connection pipe insulation material and the indoor unit pipe insulation material. Bind them together with vinyl tape so that there may be no gap.
2. Wrap the area which accommodates the rear piping housing section with vinyl tape.
3. Bundle the piping and drain hose together by wrapping them with vinyl tape for enough to cover where they fit into the rear piping housing section.

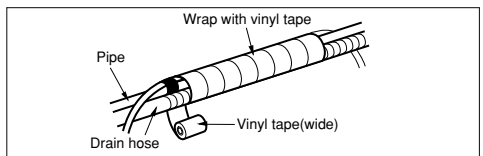
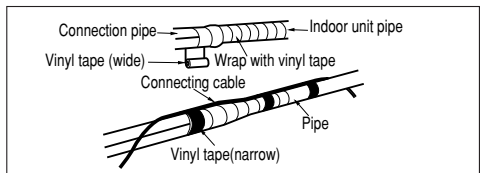
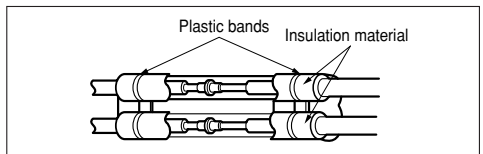

For left rear piping

1. Route the indoor tubing and the drain hose to the required piping hole position.
2. Insert the piping, drain hose, and the connecting cable into the piping hole.
3. Insert the connecting cable into the indoor unit.
 - Don't connect the cable to the indoor unit.
 - Make a small loop with the cable for easy connection later.
4. Tape the drain hose and the connecting cables.

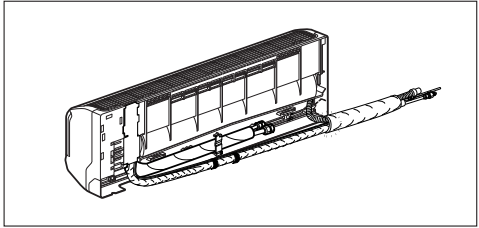
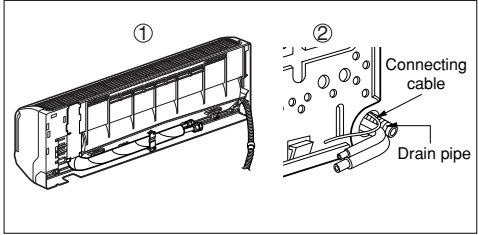

5. Indoor unit installation
 - Hang the indoor unit from the hooks at the top of the installation plate.
 - Insert the spacer etc. between the indoor unit and the installation plate and separate the bottom of the indoor unit from the wall.

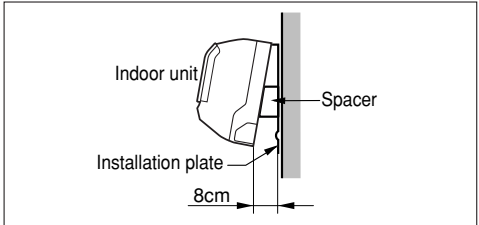

Connecting the piping to the indoor unit and the drain hose to drain pipe.

1. Align the center of the pipes and sufficiently tighten the flare nut by hand.
2. Tighten the flare nut with a wrench.

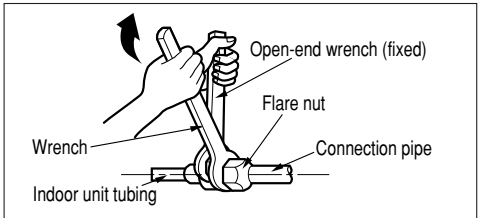
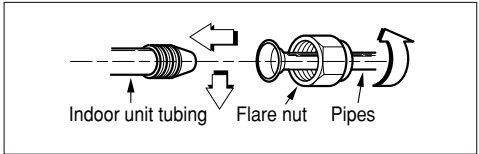

Outside diameter		Torque
mm	inch	kgf-m
Ø6.35	1/4	1.8~2.5
Ø9.52	3/8	3.4~4.2
Ø12.7	1/2	5.5~6.6
Ø15.88	5/8	6.3~8.2
Ø19.05	3/4	9.9~12.1

3. When extending the drain hose at the indoor unit, install the drain pipe.

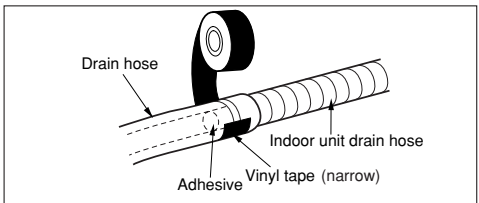

Wrap the insulation material around the connecting portion.

1. Overlap the connection pipe heat insulation and the indoor unit pipe heat insulation material. Bind them together with vinyl tape so that there may be no gap.
2. Wrap the area which accommodates the rear piping housing section with vinyl tape.

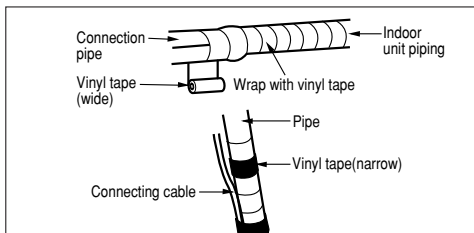
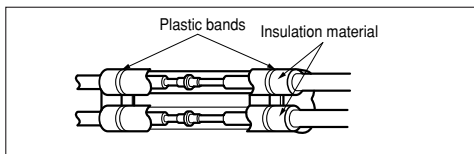

3. Bundle the piping and drain hose together by wrapping them with cloth tape over the range within which they fit into the rear piping housing section.

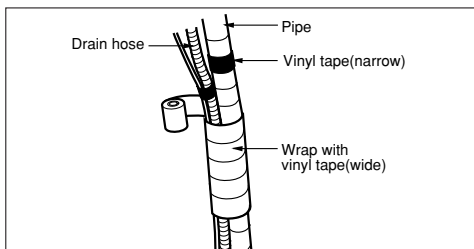

Reroute the pipings and the drain hose across the back of the chassis.

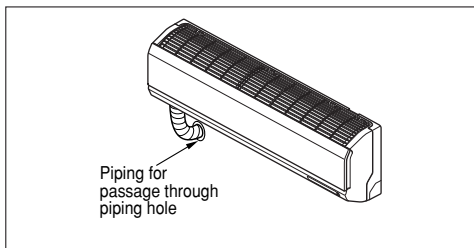

Indoor unit installation

1. Remove the spacer.
2. Ensure that the hooks are properly seated on the installation plate by moving it left and right.
3. Press the lower left and right sides of the unit against the installation plate until the hooks engage into their slots (clicking sound).

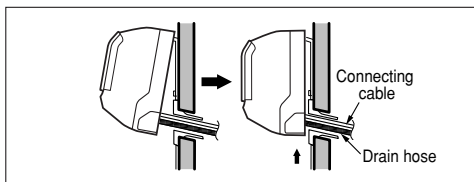

⚠ CAUTION

Installation Information. For left piping. Follow the instruction below.

Good case

- Press on the upper side of clamp and unfold the tubing to downward slowly.

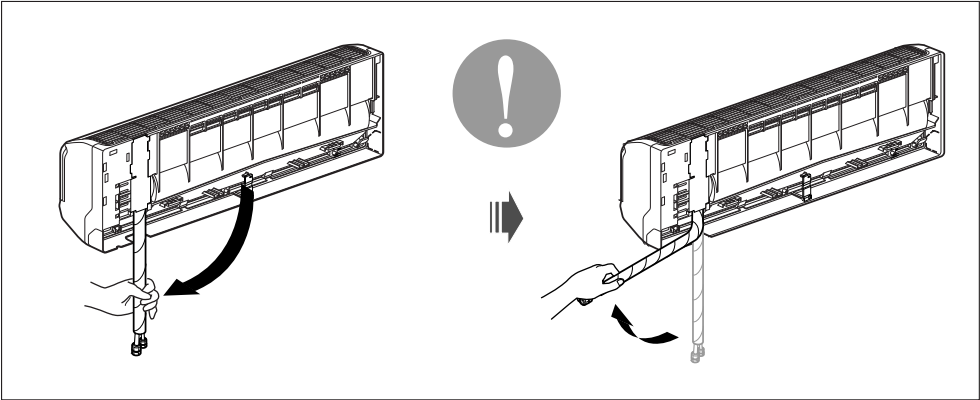
**Bad case**

- Following bending type from right to left may cause damage to the tubing.

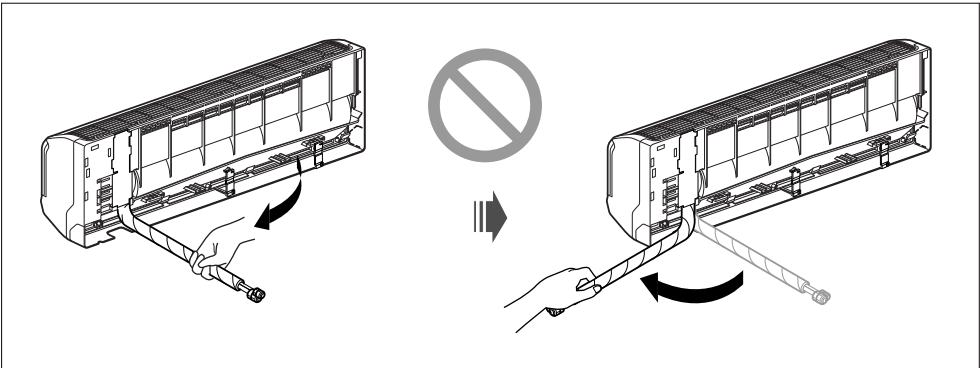

Outdoor Unit

Align the center of the pipings and sufficiently tighten the flare nut by hand.

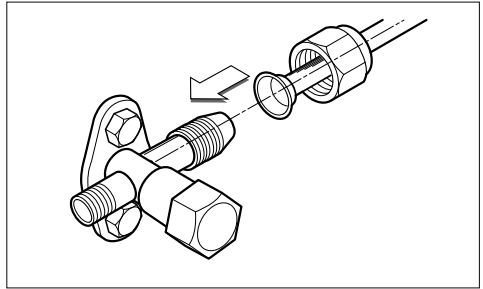

Finally, tighten the flare nut with torque wrench until the wrench clicks.

- When tightening the flare nut with torque wrench, ensure the direction for tightening follows the arrow on the wrench.

Outside diameter		Torque
mm	inch	kgf·m
Ø6.35	1/4	1.8~2.5
Ø9.52	3/8	3.4~4.2
Ø12.7	1/2	5.5~6.6
Ø15.88	5/8	6.3~8.2
Ø19.05	3/4	9.9~12.1

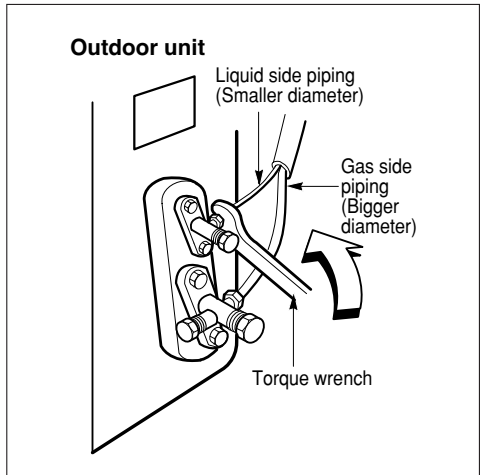

Connecting the Cables

Indoor Unit

Connect the cable to the indoor unit by connecting the wires to the terminals on the control board individually according to the outdoor unit connection. (Ensure that the color of the wires of the outdoor unit and the terminal No. are the same as those of the indoor unit.)

CAUTION

- The circuit diagram is a subject to change without notice.
- The earth wire should be longer than the common wires.
- When installing, refer to the circuit diagram on the chassis cover.
- Connect the wires firmly so that they may not be pulled out easily.
- Connect the wires according to color codes, referring to the wiring diagram.

CAUTION

The power cord connected to the "A" unit should be selected according to the following specifications (Type "B" approved by HAR or SAA).

(mm²)

NORMAL CROSS-SECTIONAL AREA	Grade			
	7k	9/12k	18k	24k
	0.75	1.0	1.5	2.5
Unit(A)	Indoor	Indoor	Indoor	Indoor
Cable Type(B)	H05VV-F	H05VV-F	H05VV-F	H05VV-F

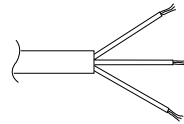

The power connecting cable connecting the indoor and outdoor unit should be selected according to the following specifications (Type "B" approved by HAR or SAA).

<Power Connecting Cable>

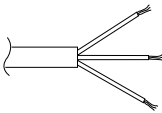

<Connecting Cable>



NORMAL
CROSS-SECTIONAL
AREA 0.75mm²

(mm²)

NORMAL CROSS-SECTIONAL AREA	Grade			
	7k	9/12k	18k	24k
	0.75	1.0	1.5	2.5
Cable Type(B)	H07RN-F	H07RN-F	H07RN-F	H07RN-F

Outdoor Unit

1. Remove the control cover from the unit by loosening the screw. Connect the wires to the terminals on the control board individually.
2. Secure the cable onto the control board with the cord clamp.
3. Refix the control cover to the original position with the screw.
4. Use a recognized circuit breaker between the power source and the unit. A disconnecting device to adequately disconnect all supply lines must be fitted.

Circuit Breaker (A)	Grade(Based on Cooling Capacity)		
	2.5~3.5kW(9~12kBtu/h)	5.3kW(18kBtu/h)	7.3kW(24kBtu/h)
	15	20	30

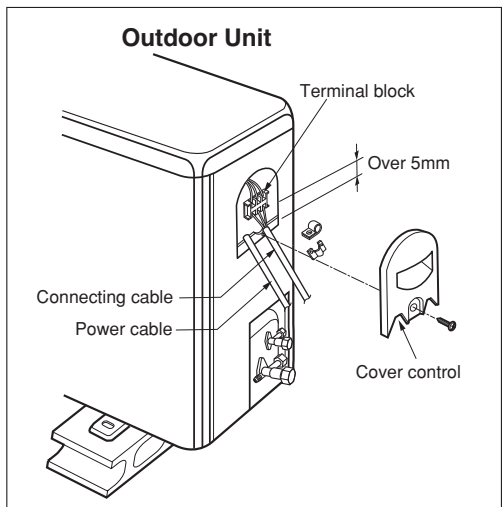

⚠ CAUTION

Provide the circuit breaker between power source and the unit as shown by

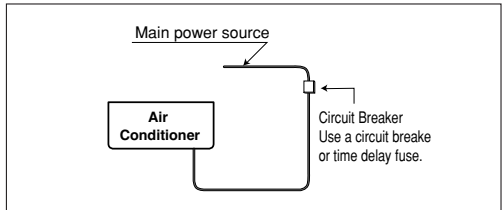

⚠ CAUTION

According to the confirmation of the above conditions, prepare the wiring as follows.

1. Never fail to have an individual power circuit specifically for the air conditioner. As for the method of wiring, be guided by the circuit diagram posted on the inside of control cover.
2. The screw which fasten the wiring in the casing of electrical fittings are liable to come loose from vibrations to which the unit is subjected during the course of transportation. Check them and make sure that they are all tightly fastened. (If they are loose, it could cause burn-out of the wires.)
3. Specification of power source.
4. Confirm that electrical capacity is sufficient.
5. See that the starting voltage is maintained at more than 90 percent of the rated voltage marked on the name plate.
6. Confirm that the cable thickness is as specified in the power source specification. (Particularly note the relation between cable length and thickness.)
7. Always install an earth leakage circuit breaker in a wet or moist area.
8. The following would be caused by voltage drop.
 - Vibration of a magnetic switch, which will damage the contact point, fuse breaking, disturbance of the normal function of the overload.
9. The means for disconnection from a power supply shall be incorporated in the fixed wiring and have an air gap contact separation of at least 3mm in each active(phase) conductors.

Checking the Drainage

To check the drainage.

1. Pour a glass of water on the evaporator.
2. Ensure the water flows through the drain hose of the indoor unit without any leakage and goes out the drain exit.

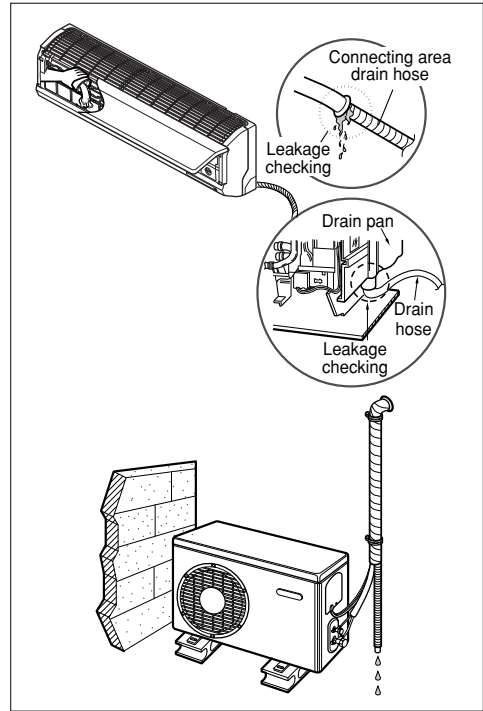

Drain piping

1. The drain hose should point downward for easy drain flow.

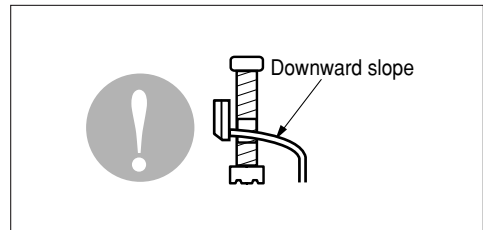

2. Do not make drain piping like the following.

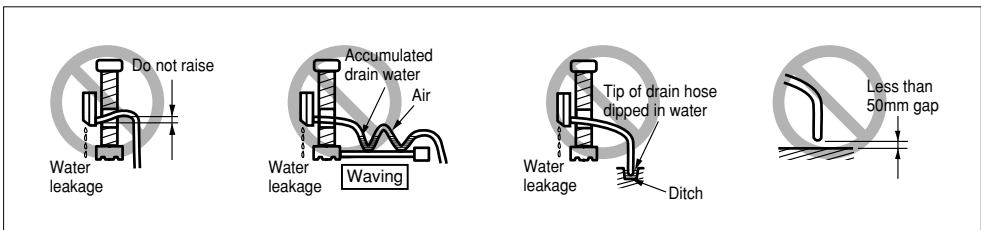

Forming the Piping

Form the piping by wrapping the connecting portion of the indoor unit with insulation material and secure it with two kinds of vinyl tapes.

- If you want to connect an additional drain hose, the end of the drain outlet should be routed above the ground. Secure the drain hose appropriately.

In cases where the outdoor unit is installed below the indoor unit perform the following.

1. Tape the piping, drain hose and connecting cable from down to up.
2. Secure the tapped piping along the exterior wall using saddle or equivalent.

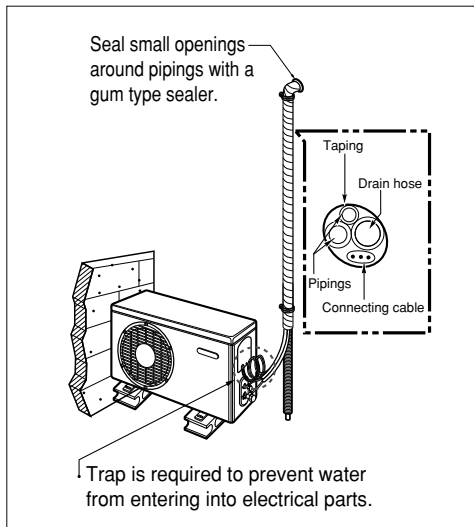

In cases where the Outdoor unit is installed above the Indoor unit perform the following.

1. Tape the piping and connecting cable from down to up.
2. Secure the taped piping along the exterior wall. Form a trap to prevent water entering the room.
3. Fix the piping onto the wall by saddle or equivalent.

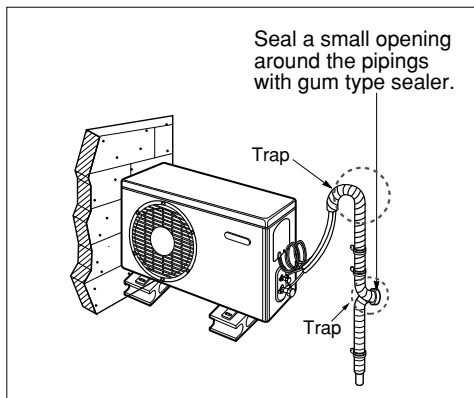

Air Purging

Air purging

The air and moisture remaining in the refrigerant system have undesirable effects as indicated below.

1. Pressure in the system rises.
2. Operating current rises.
3. Cooling(or heating) efficiency drops.
4. Moisture in the refrigerant circuit may freeze and block capillary tubing.
5. Water may lead to corrosion of parts in the refrigeration system.

Therefore, after evacuating the system, take a leak test for the piping and tubing between the indoor and outdoor unit.

Air purging with vacuum pump

1. Preparation

- Check that each tube(both liquid and gas side tubes) between the indoor and outdoor units have been properly connected and all wiring for the test run has been completed. Remove the service valve caps from both the gas and the liquid side on the outdoor unit. Note that both the liquid and the gas side service valves on the outdoor unit are kept closed at this stage.

2. Leak test

- Connect the manifold valve(with pressure gauges) and dry nitrogen gas cylinder to this service port with charge hoses.

⚠ CAUTION

Be sure to use a manifold valve for air purging. If it is not available, use a stop valve for this purpose. The "Hi" knob of the manifold valve must always be kept close.

- Pressurize the system to no more than 150 P.S.I.G. with dry nitrogen gas and close the cylinder valve when the gauge reading reached 150 P.S.I.G. Next, test for leaks with liquid soap.

⚠ CAUTION

To avoid nitrogen entering the refrigerant system in a liquid state, the top of the cylinder must be higher than its bottom when you pressurize the system. Usually, the cylinder is used in a vertical standing position.

1. Do a leak test of all joints of the tubing(both indoor and outdoor) and both gas and liquid side service valves.

Bubbles indicate a leak. Be sure to wipe off the soap with a clean cloth.

2. After the system is found to be free of leaks, relieve the nitrogen pressure by loosening the charge hose connector at the nitrogen cylinder. When the system pressure is reduced to normal, disconnect the hose from the cylinder.

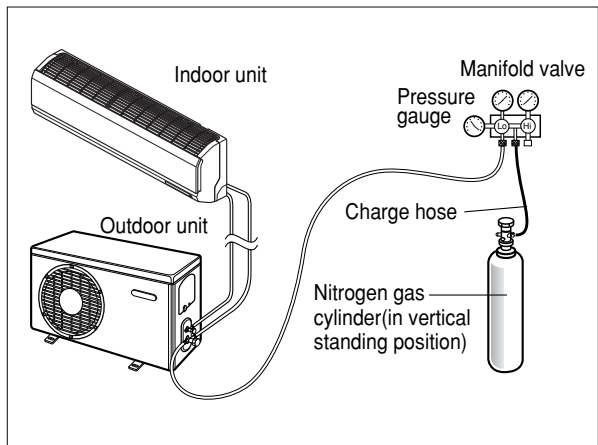

Soap water method

1. Remove the caps from the 2-way and 3-way valves.
2. Remove the service-port cap from the 3-way valve.
3. To open the 2-way valve turn the valve stem counterclockwise approximately 90°, wait for about 2~3 sec, and close it.
4. Apply a soap water or a liquid neutral detergent on the indoor unit connection or outdoor unit connections by a soft brush to check for leakage of the connecting points of the piping.
5. If bubbles come out, the pipes have leakage

Evacuation

1. Connect the charge hose end described in the preceding steps to the vacuum pump to evacuate the tubing and indoor unit. Confirm the "Lo" knob of the manifold valve is open. Then, run the vacuum pump.

The operation time for evacuation varies with tubing length and capacity of the pump. The following table shows the time required for evacuation.

Required time for evacuation when 30 gal/h vacuum pump is used	
If tubing length is less than 10m (33 ft)	If tubing length is longer than 10m (33 ft)
10 min. or more	15 min. or more

2. When the desired vacuum is reached, close the "Lo" knob of the manifold valve and stop the vacuum pump.

Finishing the job

1. With a service valve wrench, turn the valve stem of liquid side valve counter-clockwise to fully open the valve.
2. Turn the valve stem of gas side valve counter-clockwise to fully open the valve.
3. Loosen the charge hose connected to the gas side service port slightly to release the pressure, then remove the hose.
4. Replace the flare nut and its bonnet on the gas side service port and fasten the flare nut securely with an adjustable wrench. This process is very important to prevent leakage from the system.
5. Replace the valve caps at both gas and liquid side service valves and fasten them tight. This completes air purging with a vacuum pump. The air conditioner is now ready to test run.

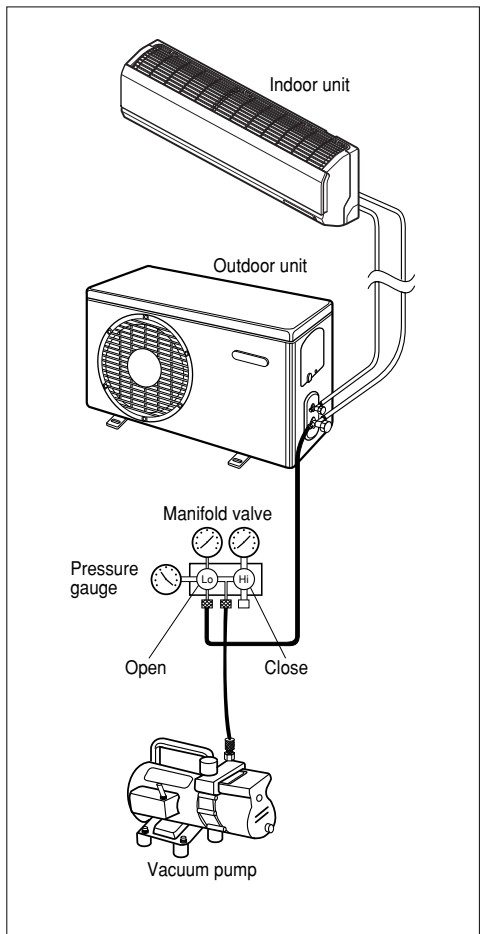
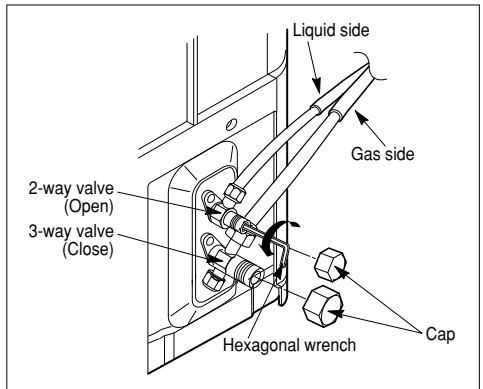

Test Running

1. Check that all tubing and wiring are properly connected.
2. Check that the gas and liquid side service valves are fully open.

Prepare remote controller

1. Remove the battery cover by pulling it according to the arrow direction.
2. Insert new batteries making sure that the (+) and (-) of battery are installed correctly.
3. Reattach the cover by pushing it back into position.

NOTICE

- Use 2 AAA(1.5volt) batteries. Do not use rechargeable batteries.
- Remove the batteries from the remote controller if the system is not used for a long time.

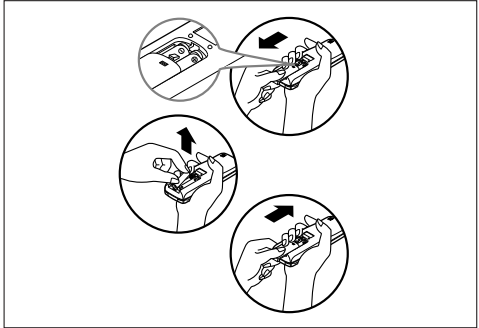

Settlement of outdoor unit

1. Anchor the outdoor unit with a bolt and nut($\phi 10\text{mm}$) tightly and horizontally on a concrete or rigid mount.
2. When installing on the wall, roof or rooftop, anchor the mounting base securely with a nail or wire assuming the influence of wind and earthquake.
3. If the vibration of the unit is transmitted to the hose, secure the unit with an anti-vibration rubber.

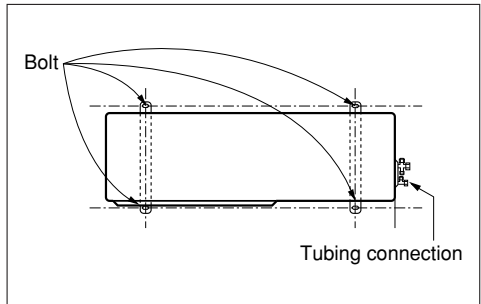

Evaluation of the performance

Operate the unit for 15~20 minutes, then check the system refrigerant charge:

1. Measure the pressure of the gas side service valve.
2. Measure the temperature of the intake and discharge of air.
3. Ensure the difference between the intake temperature and the discharge is more than 8°C
4. For reference; the gas side pressure of optimum condition is as below.(Cooling)

The air conditioner is now ready for use.

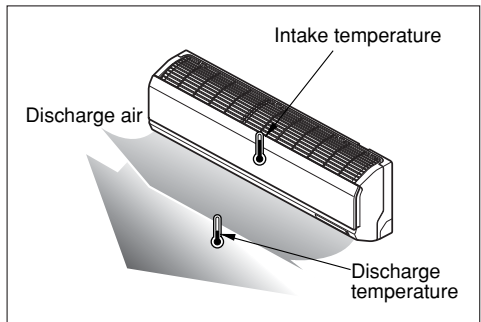

Refrigerant	Outside ambient TEMP.	The pressure of the gas side service valve.
R-410A	35°C (95°F)	$8.5\text{--}9.5\text{kg/cm}^2\text{G}$ ($120\text{--}135\text{ P.S.I.G.}$)

NOTICE

If the actual pressure is higher than shown, the system is most likely over-charged, and charge should be removed. If the actual pressure are lower than shown, the system is most likely undercharged, and charge should be added.

PUMP DOWN

This is performed when the unit is relocated or the refrigerant circuit is serviced.

Pump Down means collecting all refrigerant into the outdoor unit without the loss of refrigerant.

⚠ CAUTION

Be sure to perform Pump Down procedure in the cooling mode.

Pump Down Procedure

1. Connect a low-pressure gauge manifold hose to the charge port on the gas side service valve.
2. Open the gas side service valve halfway and purge the air in the manifold hose using the refrigerant.
3. Close the liquid side service valve(all the way).
4. Turn on the unit's operating switch and start the cooling operation.
5. When the low-pressure gauge reading becomes 1 to 0.5kg/cm² G(14.2 to 7.1 P.S.I.G.), fully close the gas side valve and then quickly turn off the unit. Now Pump Down procedure is completed, and all refrigerant is collected into the outdoor unit.

Installation guide at the seaside

▲ CAUTION

1. Air conditioners should not be installed in areas where corrosive gases, such as acid or alkaline gas, are produced.
2. Do not install the product where it could be exposed to sea wind (salty wind) directly. It can result in corrosion on the product. Corrosion, particularly on the condenser and evaporator fins, could cause product malfunction or inefficient performance.
3. If outdoor unit is installed close to the seaside, it should avoid direct exposure to the sea wind. Otherwise it needs additional anticorrosion treatment on the heat exchanger.

Selecting the location(Outdoor Unit)

- 1) If the outdoor unit is to be installed close to the seaside, direct exposure to the sea wind should be avoided. Install the outdoor unit on the opposite side of the sea wind direction.

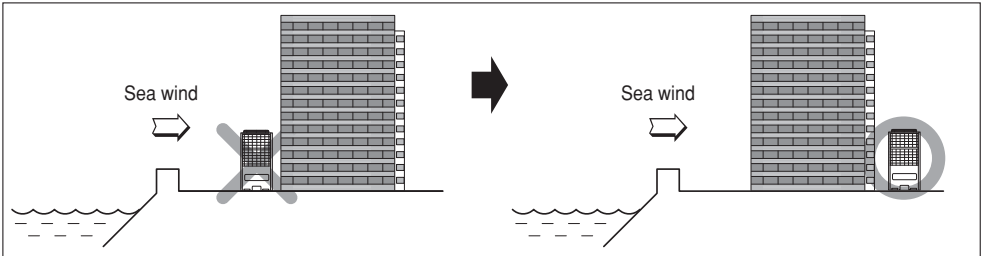

- 2) In case, to install the outdoor unit on the seaside, set up a windbreak not to be exposed to the sea wind.

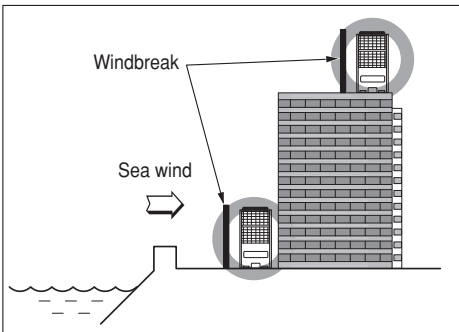

- It should be strong enough like concrete to prevent the sea wind from the sea.
- The height and width should be more than 150% of the outdoor unit.
- It should be kept more than 70 cm of space between outdoor unit and the windbreak for easy air flow.

- 3) Select a well-drained place.

1. If you can't meet above guide line in the seaside installation, please contact LG Electronics for the additional anticorrosion treatment.
2. Periodic (more than once/year) cleaning of the dust or salt particles stuck on the heat exchanger by using water

