



LG

Life's Good

OWNER'S MANUAL

Robot Vacuum Cleaner

Before using, please carefully read the Safety Precautions pages to allow for safe operation of the product. After reading the operation manual, please keep it in an easily accessible location.

LRV5900



3828F13868S

www.lg.com

FEATURES

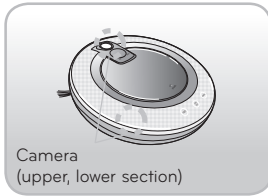

Images of the ceiling and floor are obtained from the upper and lower cameras. This establishes the location of the HOM-BOT. to accomplish elaborate cleaning of the room.

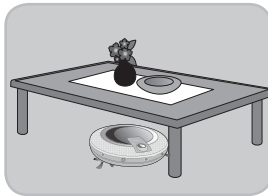

The low height of the HOM-BOT (3.54in) allows it to move freely under beds and furniture.

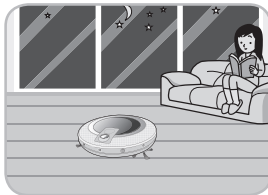

Noise levels are very low which allows cleaning to be performed at night.

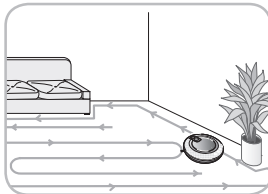

The HOM-BOT has two auto cleaning modes that can be selected by the user.
*Spatial expansion mode, zigzag mode

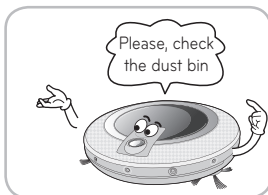

The HOM-BOT also has voice confirmation and instruction that can be easily understood by the user.

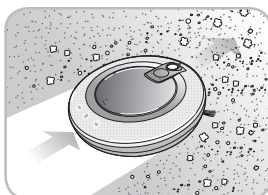

Microfiber mop attachment picks up finer dust and dirt from hardwood and other barefloor surfaces. (Sold separately)

CONTENTS

1

LG ROBOT VACUUM CLEANER WARRANTY

- 1 LG ROBOT VACUUM CLEANER WARRANTY

2

BEFORE USE

- 2 Safety Precautions
- 5 Included with Product
- 6 Parts Descriptions
- 8 Button Functions
- 10 Display Status Information
- 11 Before You Start
- 12 Overview

3

HOW TO USE

- 13 How to Install the Home Station
- 14 How to Turn the Power Supply On and Off.
- 15 How to Start and Stop Cleaning
- 16 How to Charge the Battery
- 18 Cleaning Modes
- 19 Auxiliary Cleaning Modes
- 20 Timer Cleaning
- 21 Mop Cleaning
(Mop attachment sold separately)

4

CARE AND MAINTENANCE

- 22 Cleaning the Dust Bin
- 23 Cleaning the Dust Bin Filter
- 24 Cleaning the Brush
- 25 Cleaning the Sensor/Charging Terminal
- 26 Cleaning the Side Brush
- 27 Cleaning the Ultra Microfiber Mop
(Mop attachment sold separately)

5

ADDITIONAL INFORMATION

- 28 Troubleshooting
- 31 Before You Call for Service

6

REFERENCE ITEMS

- 32 Product Specifications
- 33 Open Source Software Notice

LG ROBOT VACUUM CLEANER WARRANTY

LG Electronics Inc. will repair or replace your product, at LG's option, if it proves to be defective in material or workmanship under personal household use, during the warranty period set forth below, effective from the date of original consumer purchase of the product. This limited warranty is good only to the original purchaser of the product and effective only when used in U.S.A. and Canada.

| WARRANTY PERIOD: | HOW SERVICE IS HANDLED: |
|--|---|
| Two Years From the date of the original purchase | Any part of the robot vacuum cleaner which fails due to a defect in materials or workmanship. During this full Two Years warranty , LG will also provide, free of charge , all labor and shop service to replace the defective part. (Except-Battery 1 year warranty) |

THIS WARRANTY IS IN LIEU OF ANY OTHER WARRANTIES, EXPRESS OR IMPLIED, INCLUDING WITHOUT LIMITATION, ANY WARRANTY OF MERCHANTABILITY OR FITNESS FOR A PARTICULAR PURPOSE. TO THE EXTENT ANY IMPLIED WARRANTY IS REQUIRED BY LAW, IT IS LIMITED IN DURATION TO THE EXPRESS WARRANTY PERIOD ABOVE. LG WILL NOT BE LIABLE FOR ANY CONSEQUENTIAL, INDIRECT, OR INCIDENTAL DAMAGES OF ANY KIND, INCLUDING LOST REVENUES OR PROFITS, IN CONNECTION WITH THE PRODUCT. SOME STATES DO NOT ALLOW LIMITATION ON HOW LONG AN IMPLIED WARRANTY LASTS OR THE EXCLUSION OF INCIDENTAL OR CONSEQUENTIAL DAMAGES, SO THE ABOVE LIMITATIONS OR EXCLUSIONS MAY NOT APPLY TO YOU.

This warranty covers only defects in material and workmanship.

LGE will NOT pay for:

1. Expendable items that can wear out, including, but not limited to, filters and belts.
2. A service technician to instruct the user in correct product assembly, operation or maintenance.
3. A service technician to clean or maintain this product.
4. Damage to or failure of this product if it is not assembled, operated or maintained according to all instructions supplied with this product.
5. Damage to or failure of this product resulting from accident, abuse, misuse or use for other than its intended purpose.
6. Damage to or failure of this product caused by the use of detergents, cleaners, chemicals or utensils other than those recommended in all instructions supplied with this product.
7. Damage to or failure of parts or systems resulting from unauthorized modifications made to this product.

This warranty is extended to the original purchaser for products purchased for home use within the U.S.A. In Alaska, the warranty excludes the cost of shipping or service calls to your home.

Some states do not allow the exclusion or limitation of incidental or consequential damages, so this exclusion or limitation may not apply to you. This warranty gives you specific legal rights, and you may also have other rights which vary from states to states. To know what your legal rights are, consult your local or state consumer affairs or your state's Attorney General.

CUSTOMER ASSISTANCE INFORMATION:

| | |
|---|---|
| To Prove Warranty Coverage | Retain your Sales Receipt to prove date of purchase. A copy of your Sales Receipt must be submitted at the time warranty service is provided. |
| To Obtain Nearest Authorized Service Center or Sales Dealer, or to Obtain Product, Customer, or Service Assistance | Call 1-800-243-0000 (Phone answered 24 hours - 365 days a year) and choose the appropriate prompt from the menu; or visit our website at: http://us.lgservice.com . (In Canada- Call 1-888-542-2623, website http://ca.lgservice.com) |

SAFETY PRECAUTIONS

The purpose of the safety precautions described below is for the user to use the product safely and correctly to prevent any unexpected risk of injury or damage.

Basic safety precautions

After reading this manual, please keep it in an easily accessible location.



This is the safety alert symbol. This symbol alerts you to potential hazards that can result in property damage and/or serious bodily harm or death.

! WARNING Indicates a hazardous situation which, if not avoided, could result in death or serious injury.

! CAUTION Indicates a hazardous situation which, if not avoided, could result in minor or moderate injury.

! WARNING

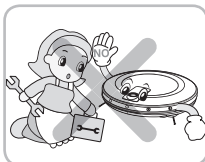

For your safety, do not remove the battery from the HOM-BOT. If you need to replace the battery take it to the nearest authorized LG Electronics service center or dealer for assistance.

Failure to follow this warning can cause fire or product failure.

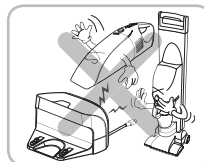

Never use the HOM-BOT with a battery and/or home station from any product other than the HOM-BOT.

Doing so can cause fire or product failure.

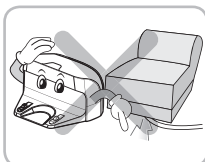

Make sure the power cord of the home station is not crushed under a heavy object or damaged by contact with sharp objects.

Failure to follow this warning can cause electric shock, fire or product failure. If the power cord is broken, do not plug it in. Take the product to the nearest authorized LG Electronics service center or dealer for assistance.

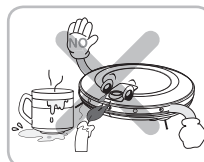

Do not use the HOM-BOT when candles or fragile objects are placed on the floor.

Doing so can cause fire or product failure.

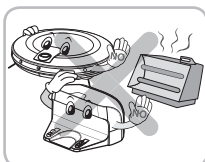

Do not place the home station and the HOM-BOT near a heating device.

Doing so can cause product deformation, fire, or product failure.

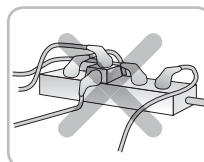

Always use a dedicated outlet.

If multiple appliances are connected to an outlet simultaneously, they can generate enough heat to cause a fire.

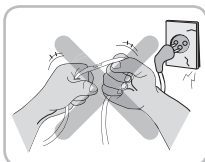

Do not force the power plug to bend. Do not use the power plug when it has been damaged or loosened.

Doing so can cause fire or product failure.

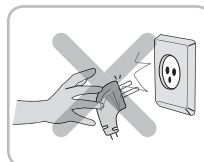

When pulling out the power plug, always pull it out by grabbing the plug, not the cord. When pulling out the power plug, do not touch the prongs with your fingers.

Doing so can cause an electric shock.

- * 1) Place the cords from other appliances out of the area to be cleaned.
- 2) Do not operate the vacuum in a room where an infant or child is sleeping.
- 3) Do not operate the vacuum in an area where there are lit candles or fragile objects on the floor to be cleaned.
- 4) Do not operate the vacuum in a room that has lit candles on furniture that the vacuum may accidentally hit or bump into.
- 5) Do not allow children to sit on the vacuum.
- 6) Do not use the vacuum on a wet surface.

SAFETY PRECAUTIONS

! WARNING



Do not touch the power plug with wet hands.
Doing so can cause electric shock.

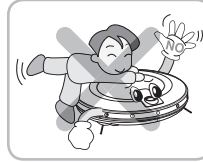

Do not allow children or pets to play with or on the HOM-BOT at any time. Do not use the HOM-BOT while an object is hanging from it.
Doing so can cause injury or product damage.

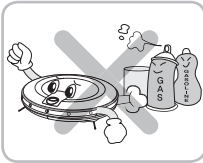

Do not spray or place flammable materials, surfactants, or water in the vicinity of the HOM-BOT.
Doing so can cause fire or product failure.
* flammable materials: gasoline, thinner, etc.
* Surfactant: detergent, articles for bath, etc.



Turn the power supply off immediately if any abnormal sound, odor, or smoke is generated from the HOM-BOT.
Failure to do so can cause fire or product failure.

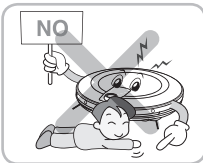

Do not insert any part of the body, such as a hand or foot, below the brush or wheels of the HOM-BOT while in use.
Doing so can cause injury or product damage.



Do not operate the HOM-BOT in a room where a child is sleeping.
Doing so can cause injury or product damage.



Do not operate the HOM-BOT on narrow and high furniture such as a wardrobe, refrigerator, desk, table, etc.
Doing so can cause injury, product failure or damage which is not covered by the warranty.

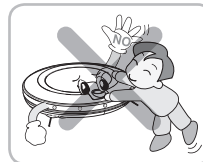

Do not leave children or pets near the HOM-BOT unsupervised.
Doing so can cause injury or product damage.

! CAUTION



Frequently empty the dust bin and keep clean.
The dust collected in the dust bin can trigger allergies and may contain harmful insects.

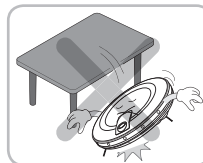

Do not drop the HOM-BOT or subject it to strong impacts.
Doing so can cause injury or product failure not covered by the warranty.

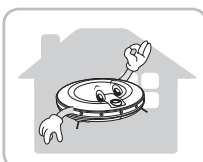

Use the HOM-BOT indoors only.
Using it outdoors can cause product failure and irreparable damage to the unit.



Do not expose the HOM-BOT to temperatures below 40°F for a long period of time.
Doing so can cause product failure.

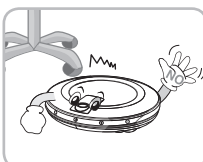

The HOM-BOT may bump into furniture such as chair legs, table legs, thin and long furniture, etc. while operating.
For a quicker and cleaner performance, place the chairs on top of the table.

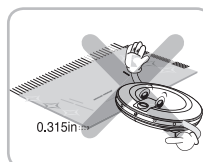

Cleaning will not proceed smoothly on carpets with tassels or carpets thicker than 0.315in.
It may be more convenient to arrange them before using the product.

SAFETY PRECAUTIONS

⚠ CAUTION

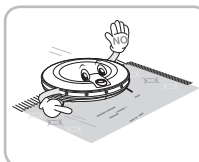

In rare cases, the HOM-BOT's brush can damage the carpet. If this happens, immediately stop the cleaning operation.

When a carpet has long tassels, the tassels can be damaged.

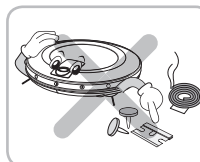

Do not allow the HOM-BOT to sweep up liquids, blades, thumb tacks, kindling, etc.

These items can cause product failure.

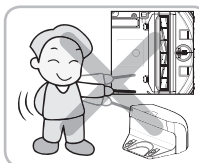

Do not let the main frame and charging terminal of the home station come into contact with metallic objects.

Doing so can cause product failure.

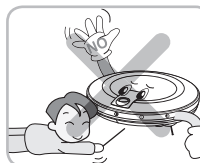

Do not put sharp objects into the opening of the HOM-BOT's super-sonic sensor.

Doing so can cause product failure.



Do not use water, detergent, etc. on the HOM-BOT.

Doing so can cause product failure. Do not put any water or detergent on the HOM-BOT. If liquids get inside of the HOM-BOT, turn off the power supply and contact an LG Electronics sales agent or customer care center.

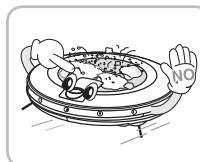

Do not use the HOM-BOT when the dust bin is completely filled up.

Doing so can cause product failure.



If the floor is wet or has wet spots, wipe them up before using the HOM-BOT. Do not use the HOM-BOT on a wet surface.

Failure to do so can cause product failure.

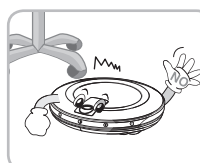

When the robot cleaner is operating, it may come in contact with chair, desk or table legs.

For quicker and better cleaning, place the dining chairs on top of the dining table.



Tip

Check the following items before use:

- Remove fragile or unnecessary objects from the room to be cleaned. For example, remove expensive ceramics and valuables from the floor.
- Do not use this product in the room if a child is sleeping on the floor. The child can be hurt.
- Confirm whether the battery has sufficient power, and if it is low, recharge it.
- Empty the dust bin after it fills up.
- Close the doors of any room that you do not want the HOM-BOT to enter. During cleaning, the HOM-BOT may enter another room and continue cleaning.
- Wipe up any liquids from the floor before cleaning.
- Remove any cables or long strings from the floor.
- Remove cables, strips, towels, socks, etc. from the floor so they will not get caught by the brush.
- Cleaning will not proceed smoothly on carpets with tassels or carpets thicker than 0.315 in. It may be more convenient to remove or rearrange the position of these rugs or carpets before using the product.

Please note, this product is not intended for use in any workshop, commercial office, garage or outdoor environment. It is for internal normal indoor residential use only.

INCLUDED WITH PRODUCT

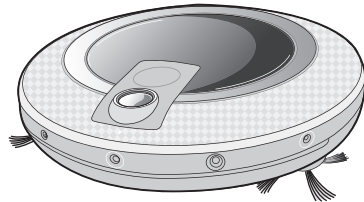

HOM-BOT



Remote controller

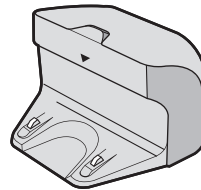

Home station

► Figures can be different from actual objects.

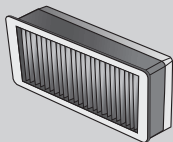

Dust bin filter (spare)

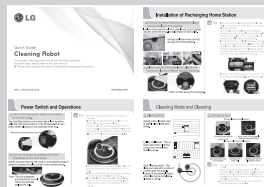

Quick guide



Operation manual

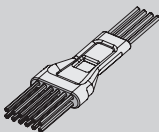

Brush for cleaning filter

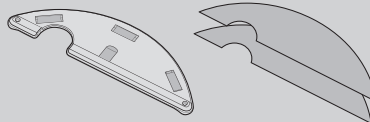

Mop plate Ultra microfiber mop (2 pieces)
(Sold separately.)



Dry cell for remote controller (2 AAA size)

PARTS DESCRIPTION - HOM-BOT

Top

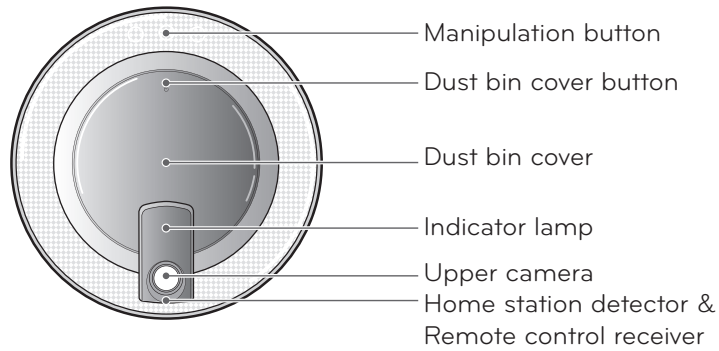

Front view

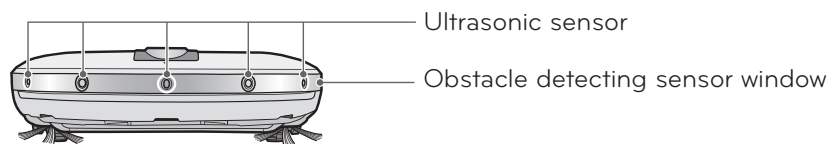

Rear view



Bottom view

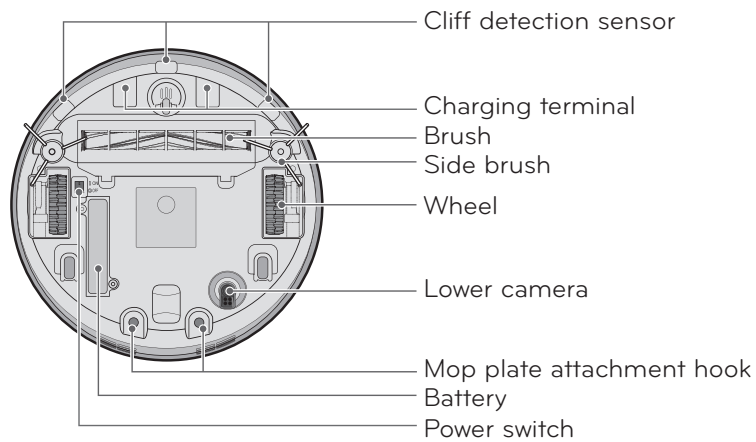

► Figures can be different from actual objects.

PART DESCRIPTION – HOME STATION / DUST BIN

Home station

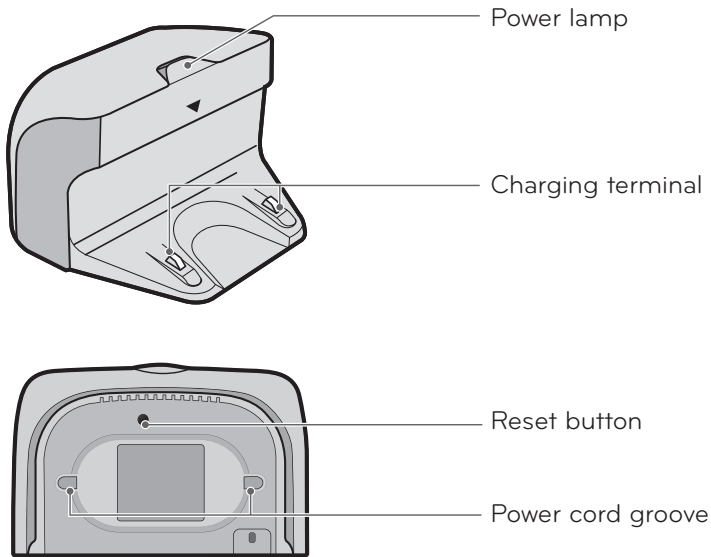

Dust bin

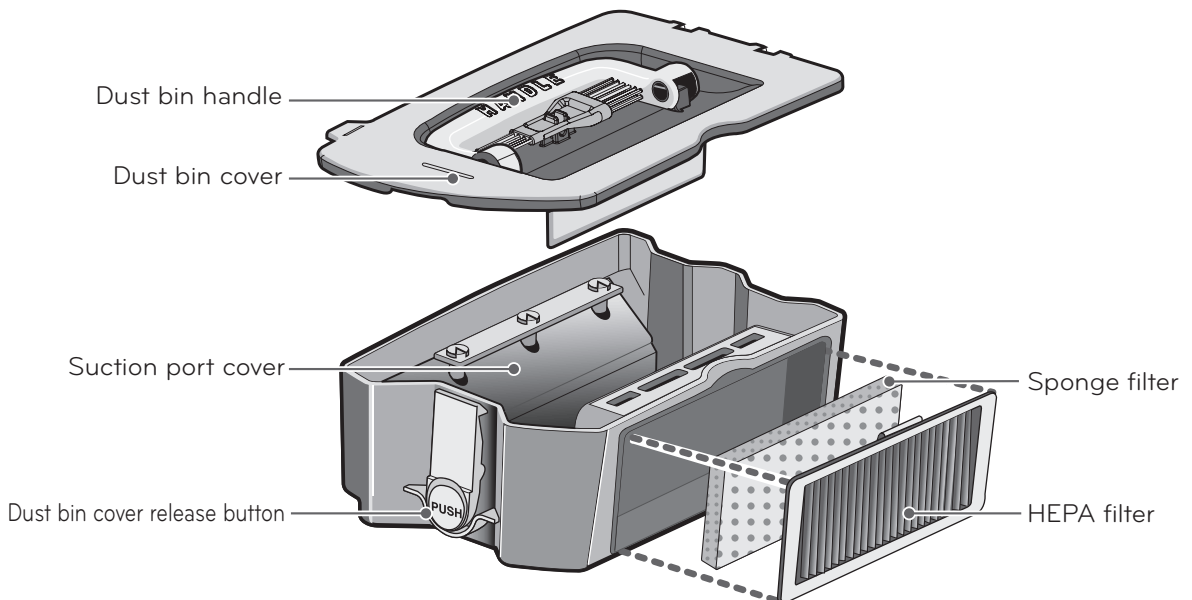

► Figures can be different from actual objects.

BUTTON FUNCTIONS – HOM-BOT

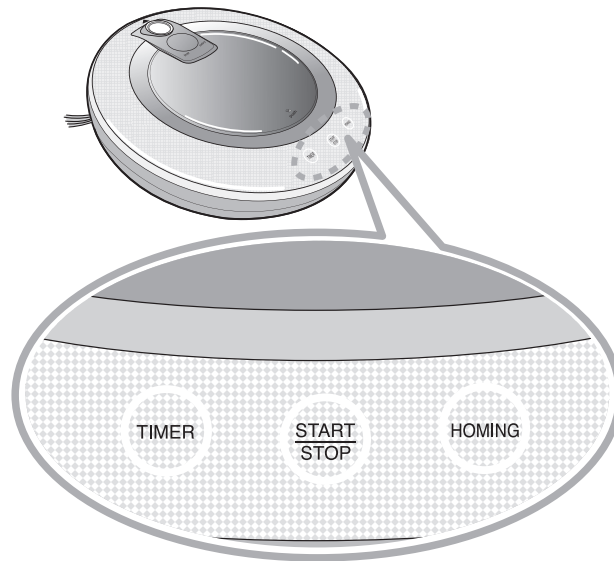

TIMER

- Use the TIMER button to activate the time delay feature.
- The timer can be set from 1 to 12 hours.
- The timer button only works when the HOM-BOT is attached to the home station. Always attach HOM-BOT to the home station when setting the timer function

START/STOP

- Press the START/STOP button to turn the HOM-BOT on/off or start/stop cleaning.
- Press the START/STOP button while the HOM-BOT is on and it will automatically start cleaning.
- If the START/STOP button is pressed during automatic cleaning, the HOM-BOT will stop cleaning.
- Press and hold the START/STOP button for approximately two seconds to turn off the HOM-BOT. This puts the HOM-BOT into the Stand By mode
- If the button is pressed while in the timer mode, the timer setting will be canceled.

HOMING

- Press the HOMING button to move the HOM-BOT to the home station for battery charging.
- When cleaning is complete or the battery is low, the device will automatically move to the home station to charge the battery even without pressing the HOMING button.
- If the home station is obstructed, the HOM-BOT may not be able to find it's signal and return to it.

BUTTON FUNCTIONS – REMOTE CONTROL

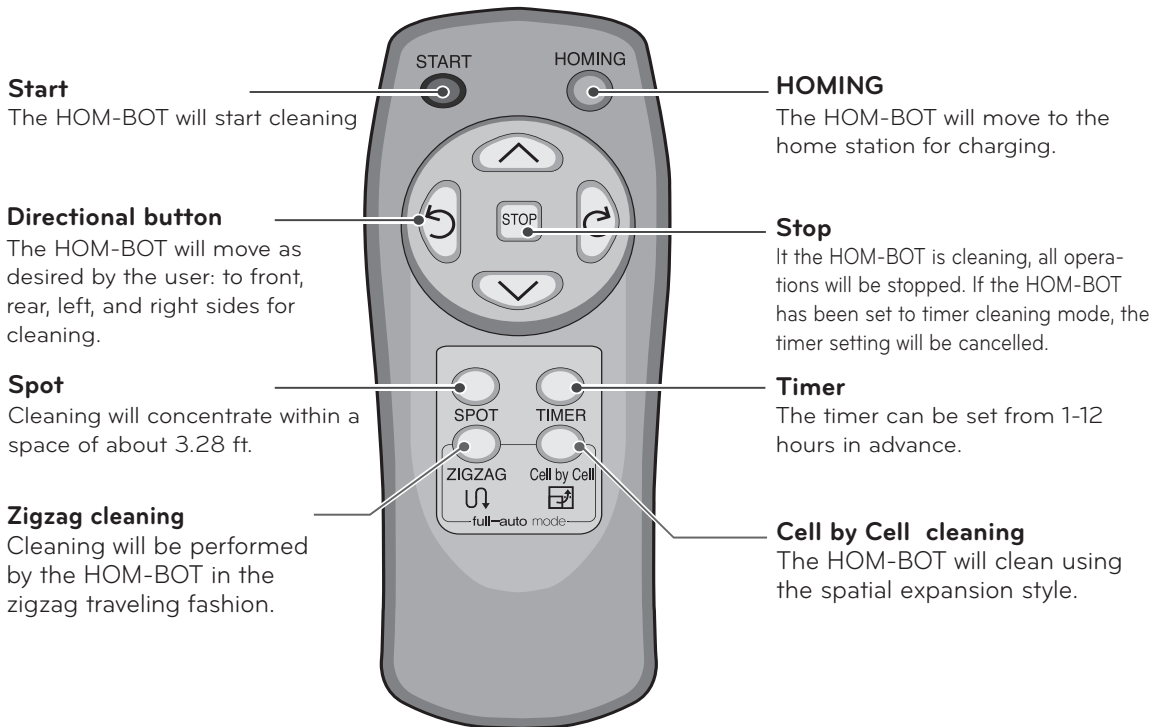

- Tip**
- The HOM-BOT's power supply cannot be turned on with the remote control.
 - To turn on the power supply, turn over the unit and flip the switch to 'On' position.
 - In order to do spot cleaning, timer cleaning, zigzag cleaning, and spatial expansion cleaning, you must first stop the operation of the HOM-BOT.
 - If the main power switch on the underside of the HOM-BOT is turned off, the remote will not function, and the battery cannot be charged.
 - If the main switch on the underside of the HOM-BOT is in the off position, the Status display will flash and sound when the unit is manually placed onto the home station, to indicate that the main switch is off.

DISPLAY STATUS INFORMATION

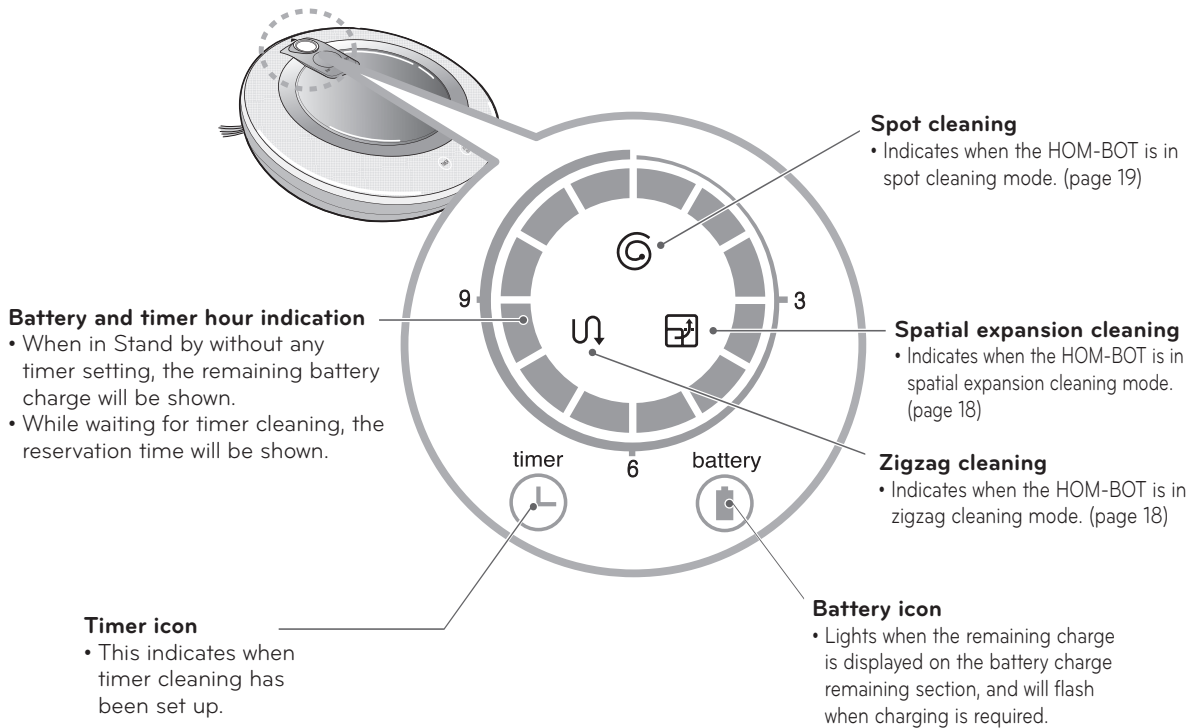

Tip

- Use the remote control to change the cleaning mode.
- Once the cleaning mode has been selected, it will be saved and automatically selected when the unit is turned on again, unit it is changed again.
- To cancel the timer setting, press the STOP button on the remote control or the START/STOP button on the HOM-BOT.

BEFORE YOU START

Check these items before cleaning

- Do not use this device in a room where a child is left alone. The child could be injured.
- Remove any fragile or valuable items from the floor of the room that is to be cleaned.
- Remove any moisture that might be on the floor.
- Remove cables, strips, towels, socks, etc. from the floor so they will not get caught by the brush.
- Confirm whether battery charge is sufficient, and if it is low, recharge it.
- Empty the dust bin if it is full.
- Close the doors of any room that you do not want the HOM-BOT to enter.

Loading the remote control battery

1. Open the battery cover by lifting the rear hook of the remote control.
2. Insert two AAA batteries, checking for +, - nodes while loading.
3. Close the battery cover completely so that the batteries will not fall out.

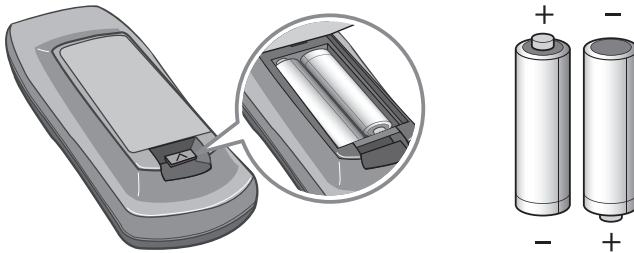

Precautions while using the remote control

- Only press one button at a time.
- Do not drop or subject it to forceful impact.
- Do not store it near devices that give off heat, fire or hot air.
- Certain fluorescent lamps, such as 3 wavelength fluorescent lamps, can interfere with the activation of the remote control. Therefore, use it as far away as possible from such lamps.
- If the remote control is too far from the HOM-BOT when operated, it may fail to operate properly. Use the device within 9.84 ft of the HOM-BOT if possible.

OVERVIEW

1

Install the home station. (page 13)

Insert the power cord plug into an outlet and locate the station against a wall. If power is not supplied to the home station, the HOM-BOT will not charge.

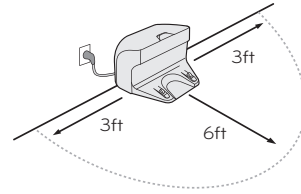

2

Turn on the power supply of the HOM-BOT. (page 14)

Turn on the power switch located on the bottom of the HOM-BOT to turn on the power supply.

* If the power supply is not turned on, refer to page 14.

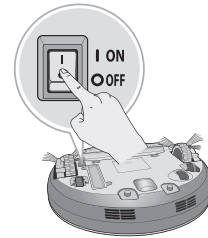

3

Start cleaning. (page 15)

Press the START/STOP button once to turn on. Press once more to start cleaning.

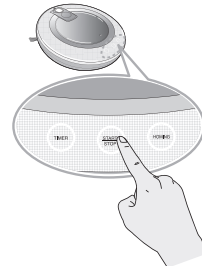

4

Automatic charge. (page 16-17)

The HOM-BOT will self-diagnose and automatically return to the home station to recharge before the complete discharge of the battery. It can take up to three hours to fully charge the battery.

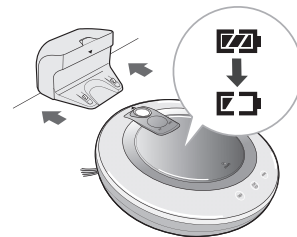

5

Use of cleaning methods and auxiliary functions. (page 18-21)

The cleaning method and auxiliary functions can be selected with the remote control.

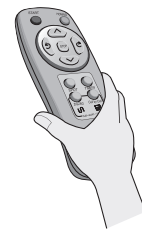

HOW TO INSTALL THE HOME STATION

How to Install the Home Station

1. Position the home station against a wall on a hard level surface to prevent sliding during docking. Remove objects within 3ft to the right and left side and within 6ft to the front.

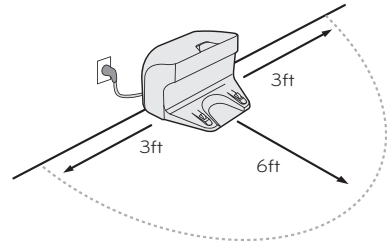
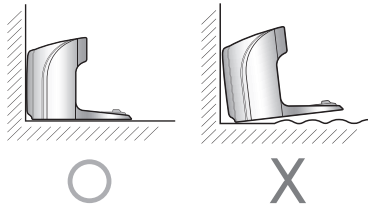

2. Plug the power cord into an outlet.

Wrap the power cord around the fixed hanger on the back side of the home station or along the wall surface so that the travel path of the HOM-BOT will not be obstructed.

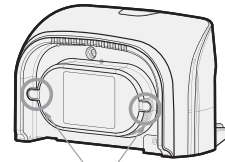
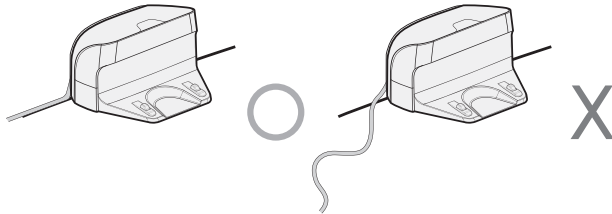

Power cord groove

3. Fix the home station against the wall so that it does not move.

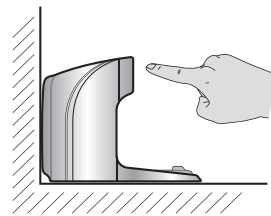

- Tip**
- Always keep the home station plugged in. If the home station is not plugged in, the HOM-BOT will not return to the station to charge automatically.
 - Do not operate the Home Station if it has a damaged cord or plug, if it is not working properly, or if it has been damaged or dropped. To avoid any electrical hazard, the cord must be replaced by LG Electronics, or a qualified service person.

HOW TO TURN THE HOM-BOT POWER SUPPLY ON & OFF

Turning on the main power supply

To turn the power supply on, turn the HOM-BOT upside down on a smooth/soft surface and check whether the main power supply switch is turned on.

If the main power supply switch is turned off, turn on the switch.

- ※ When turning on the power switch, do not press the button located at the upper section of the HOM-BOT. Operation of the button can be delayed.
- ※ Turn off the power switch if the HOM-BOT will not be used for a long period of time, in order to protect the battery.
- ※ The power switch cover is used for protecting the switch from the dust. Always keep the cover attached.

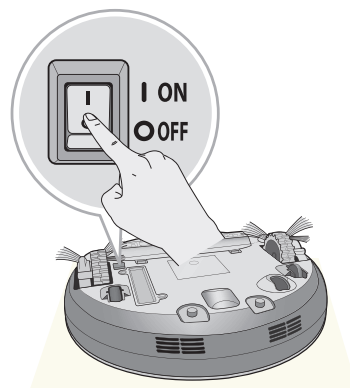

Turning on from Stand By mode.

When the HOM-BOT is not at the Home Station, and is in the Stand by mode, press the 'START/STOP' button for more than 1 second. The HOM-BOT will be turned on and a melody will be sounded.

- ※ If the power is turned on while the HOM-BOT is not at the Home Station, and nothing is done for ten minutes, the unit will turn off and enter Standby mode to reduce battery consumption.

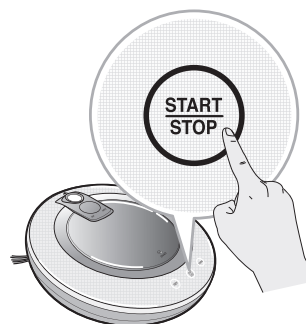

Turning off the unit

Press the START/STOP button for two seconds while the HOM-BOT is turned on. A melody will sound when the power is turned off.

- ✓ **Tip**
- The power can be turned off due to the static electricity during the operation.
 - If the power is turned off, turn off the main power switch and then turn it back on.
 - If the power cannot be turned on, do the following.
 - Turn on the power switch and wait for more than 3 seconds.
 - Press the 'START/STOP' button when the power switch is turned on.
 - If the power is not turned on or if there is no display but only the "Ting" sound, put the HOM-BOT on the home station.
 - If there is no change even when HOM-BOT is attached to the home station, press the reset switch located on the rear side of the home station while the HOM-BOT is attached on the home station.

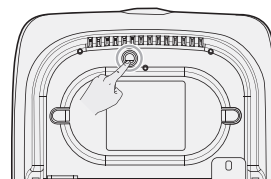
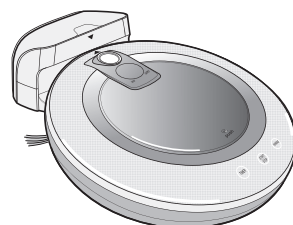

HOW TO START AND STOP CLEANING

Using the buttons on the HOM-BOT

After the HOM-BOT is turned on, press the START/STOP button to begin cleaning. A melody will sound and cleaning will begin.

Press the START/STOP button during the cleaning cycle to stop cleaning.

※ When the 'START/STOP' button is pressed while the power supply is turned off, the unit will not turn on.

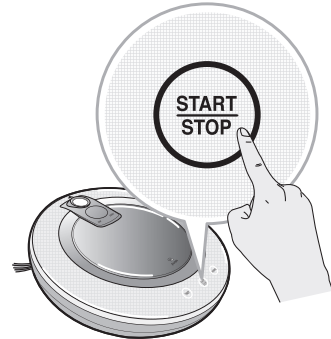

Using the remote control

After the HOM-BOT is turned on, press the START button on the remote control. A melody will sound and cleaning will begin.

Press the STOP button during the cleaning cycle to stop cleaning.

※ The Hom-Bot cannot be turned on from Standby mode using the remote control. To turn on the unit, press the 'START/STOP' button on the body, and then use the remote control to operate.



※ When the START button on the main unit or remote control is pressed, HOM-BOT will start cleaning in 'Spatial expansion' mode.

※ During cleaning, collisions can happen when the sensor cannot detect objects because of their shape. When this happens, the internal impact detecting sensor will activate and engage a backward motion.

※ If the HOM-BOT is set to start cleaning at a location away from the home station, put the device on a flat floor in order to prevent a malfunction of the obstacle detecting sensor. In addition, start cleaning from a location where there are no obstacles such as curtains or walls within 11.8in. of the HOM-BOT.

✓ **Tip** For best results:

- Briefly scan the area to be cleaned for big and small objects that may cause difficulty for the HOM-BOT.
- If cleaning is started when the HOM-BOT is at the home station, the device can rapidly be returned to the home station as the current home position has been accurately read.

HOW TO CHARGE THE BATTERY

Automatic charging

The HOM-BOT returns to the home station at the end of a cleaning cycle or when its battery is running low.

- ※ In the event that the unit returns to the Home Station due to a low battery, cleaning will be started, after the charging, from the nearest place of the area which has not been cleaned before.
- ※ If the HOM-BOT is unable to dock to the home station on its first attempt, it will try again until it docks successfully.
- ※ When the HOM-BOT has cleaned all areas that it can clean, it will return to the home station even when the battery level is not low.

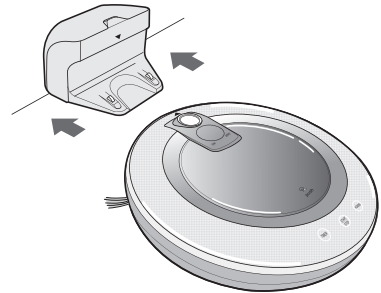

Manual charging

If using the HOM-BOT for the first time or to charge the battery by interrupting the cleaning, you can manually charge the battery.

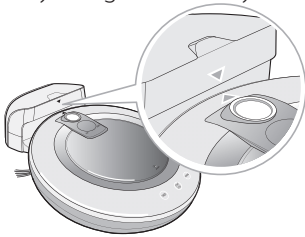

Method 1. Attach the HOM-BOT to the home station by matching up the two arrows on the HOM-BOT and the home station. A melody will sound and charging will begin.

- ※ When the HOM-BOT is attached to the home station, and a "TING" sound is generated repeatedly, please check and ensure that the power supply on the underside of the HOM-BOT is in the ON position.

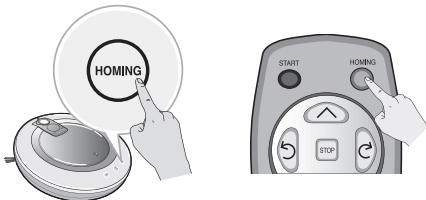

Method 2. When the HOMING button of the remote control or the HOM-BOT is pressed, charging will start automatically when the HOM-BOT has returned to the Home Station.

- ※ When the unit is turned on from Standby mode and is within 4in of the home station, the unit will automatically dock itself to the station and charging will begin.



Tip

Take the following precautions when using the home station:

- If foreign material is caught in the charging terminal, charging may not proceed smoothly. Wipe the terminal from time to time with a dry cloth after the power plug is disconnected.
- To prevent electric shock, do not touch the charging terminal with any metallic objects.
- To avoid fire or electric shock, never disassemble or modify the home station.
- Do not to place the home station or power plug near a heating appliance.

HOW TO CHARGE THE BATTERY

Remaining Battery Charge Indicator

The remaining battery charge can be confirmed from the charge indication lights, which will indicate charge as follows:

- During charging, the charge remaining indication lights will flicker.
- When charging is completed at the home station, only the battery icon will illuminate to save power.
- The battery icon will flicker when battery charging is required.

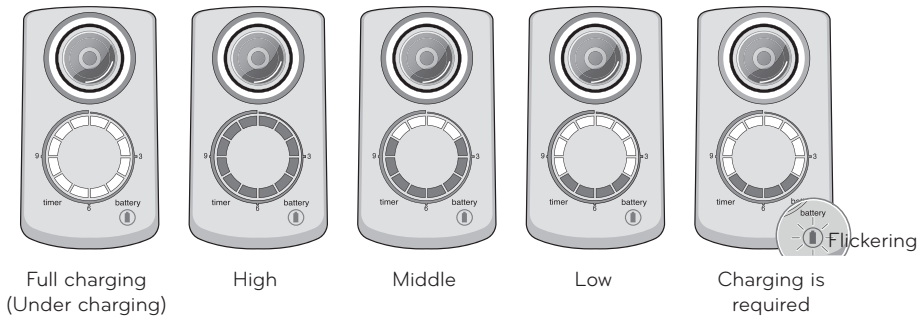

- ※ If there is still an area to be cleaned and it returned to the home station for recharging, the cleaning mode indicator will be displayed.
 - When the battery is fully recharged, it cleans the area that is yet cleaned.
 - If the cleaning mode indicator is lit during charging, pressing the 'START' button of the remote controller or 'START/STOP' button of the HOM-BOT will search the un-cleaned area and start the cleaning.
 - Pressing the mode selection button on the remote, (ZIGZAG, Cell by Cell) will start the cleaning from the beginning.

The status indication lamp while robot is charged.
(In spatial expand mode)

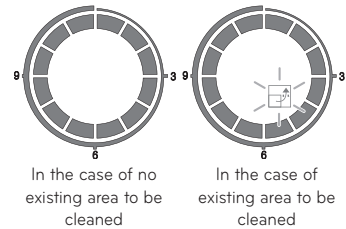

If the Battery is Not Charging

Check 1. If the battery is not charging even when the HOM-BOT is attached to the home station, check the following items.

- Turn the power switch on the bottom of the HOM-BOT off and then on again.
- Unplug and plug in the power plug on the home station.
- Wipe the terminal on the home station with a dry cloth.

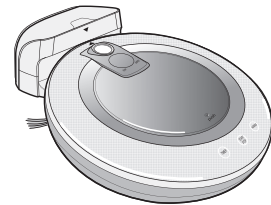

Check 2. If the battery is still not charging after the previous check, try the following.

- Attach the HOM-BOT to the home station.
- Press the reset button at the rear of the home station for three seconds.

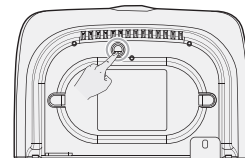

CLEANING MODES

Zigzag cleaning

Use the zigzag cleaning method when rapid cleaning is desired. When the "ZIGZAG" button on the remote control is pressed, zigzag cleaning will begin and the zigzag indicator light will come on.

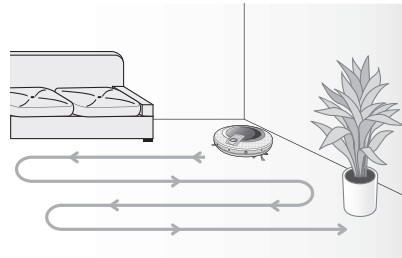
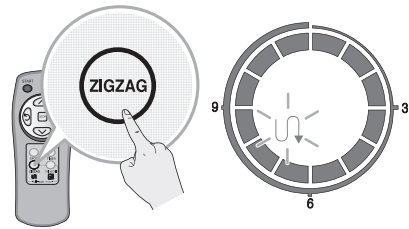

Spatial expansion cleaning

With spatial expansion cleaning, the cleaning will be performed by dividing the inside of the house into partial square spaces.

If elaborate cleaning is desired, use the spatial expansion cleaning mode.

When the "Cell by Cell" button on the remote control is pressed, spatial expansion cleaning will begin and the spatial expansion indicator light will come on.

First stage : The maximum outline of the cleaning area can be 9.84ft X 9.84ft. The actual area will depend on the size and shape of the room.

Second stage : The inside of the outline determined in the first stage will be cleaned with a zigzag pattern.

Both the first and second stages will continue until the room has been completed. The HOM-BOT will then move to the next room and begin again.

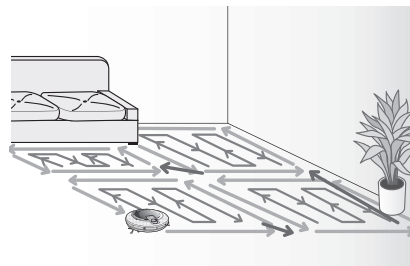
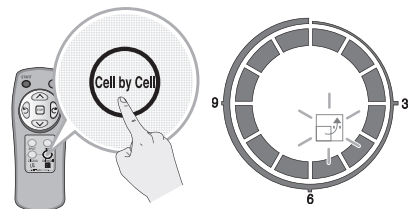

Tip

- The cleaning mode can only be changed with the remote control.
- Once selected, the cleaning mode will be maintained even after the power supply is turned off.
- During operation, if a cleaning change is required, press the STOP button and then select the mode.

AUXILIARY CLEANING MODES

Manual cleaning

This method of cleaning involves manually moving the HOM-BOT by pressing the directional (arrow) buttons on the remote control.

Hom-Bot will clean as it is being moved to the front, rear, or rotated to the left and right side according to the input of the directional buttons.

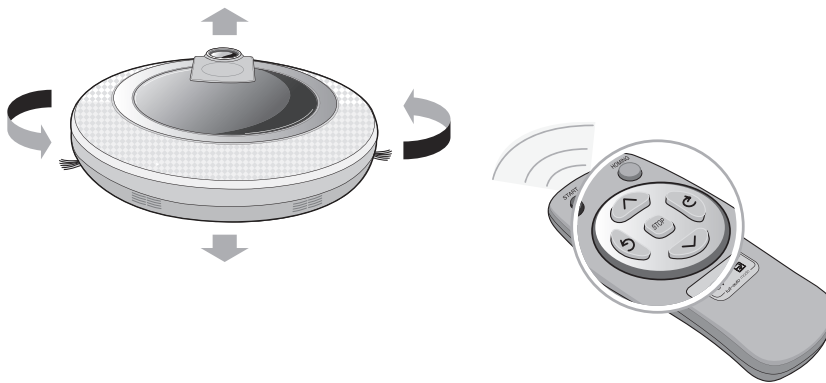

Spiral Spot Cleaning

Use this cleaning method when concentrated cleaning of a small interior space is required.

After moving the HOM-BOT to the location to be cleaned, press the SPOT button on the remote control.

The spot cleaning icon will illuminate on the HOM-BOT, and concentrated cleaning will be performed for a space within a radius of 3.28 ft.

※ During charging, the spot cleaning button on the remote control will not activate.

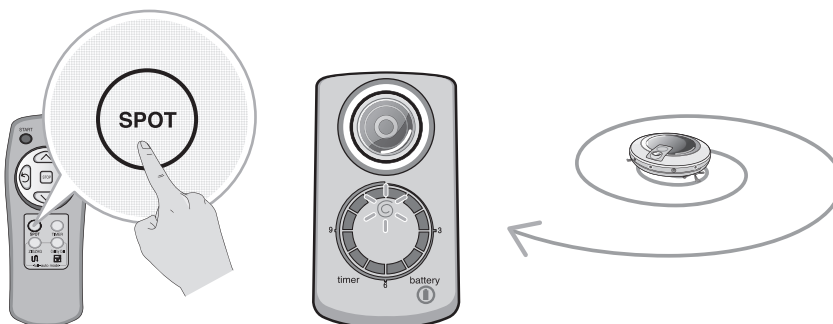

TIMER CLEANING

Set the timer to schedule the cleaning and begin in 1-12 hours.

1. By pressing the TIMER button on the remote control or the HOM-BOT, a cleaning start can be scheduled.

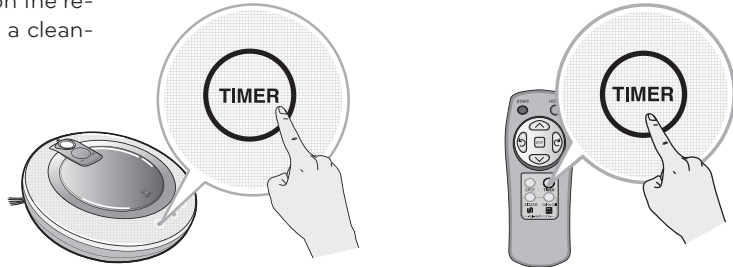

2. Adjust the time as much as desired by multiple presses of the TIMER button. Each time you press the button, the time will increase by one hour.

- The start time can be set up to a maximum of 12 hours and once set up, the time will be indicated by the status indication lamps.

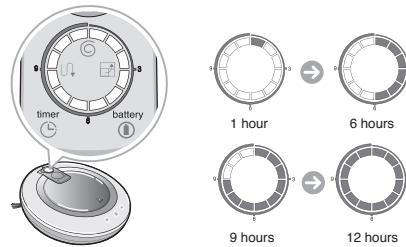

3. After setting up the start time, press the START/STOP button on the HOM-BOT or wait about five seconds. When the timer setting is complete, a melody will sound, and the timer indicator will remain on.

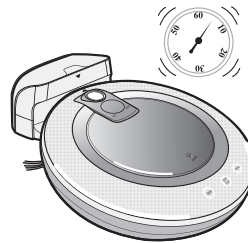

Tip

- When the set up time elapses, cleaning will begin automatically.
- Use the timer setting when the HOM-BOT is attached to the home station. If the timer is set up when the HOM-BOT is detached from the home station, the cleaning time may not be accurate.
- To cancel the timer setting during the set up time, press the STOP button on the remote control or the START/STOP button on the HOM-BOT.

MOP CLEANING (Mop attachment sold separately)

By attaching the ultra microfiber mop, you can effectively use the HOM-BOT to remove dust.

When the mop plate is attached, the HOM-BOT will not climb on to carpets or over thresholds, in order to prevent transferring dirt from the mop.

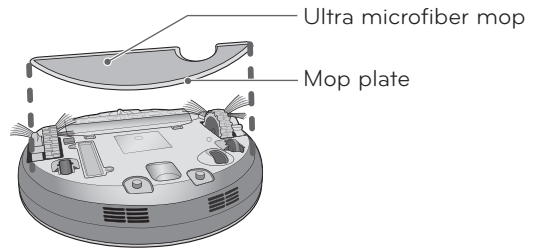

For mop cleaning, mount the mop and mop plate to the HOM-BOT according to the following instructions:

1. Attach the ultra microfiber mop to the Velcro of the mop plate as shown in the figure.
* To prevent the HOM-BOT from malfunctioning, do not cover the attaching guide with the mop.

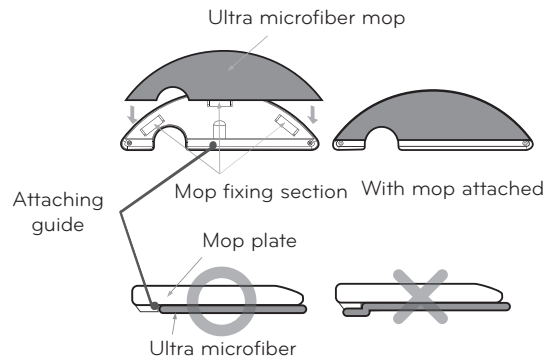

2. Accurately match up and insert the mop plate fixing hook on the lower section of the HOM-BOT into the fixing groove of the mop plate.

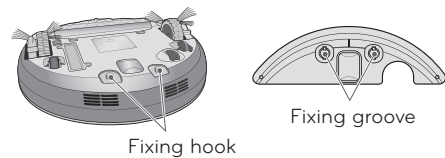

3. When you accurately match up and press the mop plate to the rear side of the HOM-BOT, it will mount with a clicking sound.
* Be careful to properly mount the mop plate, or it can separate during cleaning.

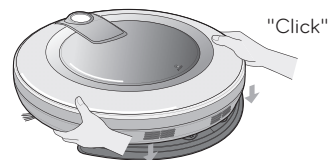

Tip

- To avoid odors, wash any foreign material or dust off the mop after cleaning is complete.
- To avoid staining floors, do not use the ultra microfiber mop to clean when dirt is mixed with liquids such as coffee or ink.
- To avoid damage to carpets from the Velcro or dirt transfer from the mop, do not clean the carpet while the mop plate or mop is attached.
- Keep the ultra microfiber mop dry. Do not use it on wet surfaces.

CLEANING THE DUST BIN

If the dust bin is full, suction power can be reduced. Clean the dust bin before and after each cleaning session. Clean the dust bin using the following sequence:

1. Open the dust bin cover by pressing the PUSH button on the HOM-BOT.
2. Grab the handle of the dust bin and pull it upward.
3. Separate the HEPA filter and the inside sponge filter by removing the HEPA filter
※ To clean the dust bin filter, refer to page 23.
4. Lift the cover upward while pressing the separation button on the dust bin.
5. Empty the dust bin and clean it with a cleaning brush or under running water.
6. After cleaning with water, completely dry the dust bin in a well-ventilated area out of the direct sunlight.
7. When you have completed cleaning the dust bin, close the cover and replace the sponge filter and HEPA filter.
8. Put the dust bin into the HOM-BOT and close the dust bin cover.

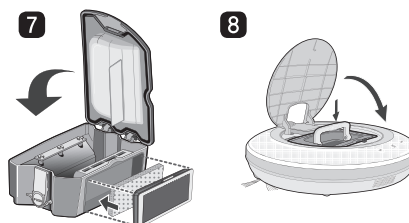
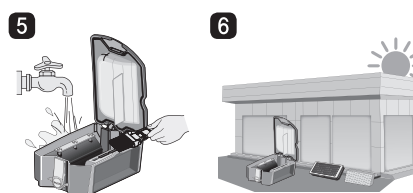
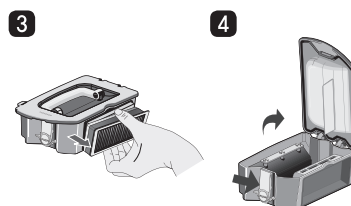
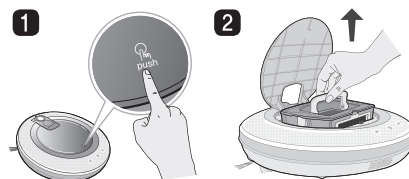

-  **Tip** • After cleaning, always mount the dust bin filters (HEPA filter, sponge filter) to the dust bin. If they are not mounted, dust may enter the HOM-BOT interior and cause product failure.

CLEANING THE DUST BIN FILTER

The dust bin filters are comprised of the HEPA filter and the sponge filter. Clean the HEPA filter and the sponge filter according to the following sequence:

1. Separate the HEPA filter and the inside sponge filter by removing the HEPA filter (as shown).

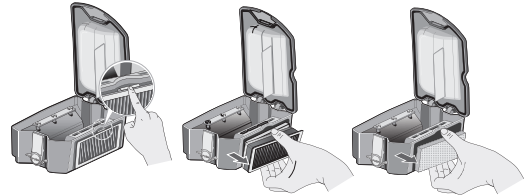

2. Carefully clean any fine dust off the HEPA filter and the sponge filter with a vacuum cleaner or water.

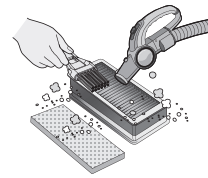

3. After washing the HEPA filter and the sponge filter with water, place them out of direct sunlight and allow them to dry completely.

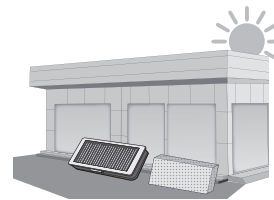

4. Mount the cleaned HEPA filter and sponge filter into the dust bin according to the sequence shown to the right. When assembling the filter, the filter handle should face upward.

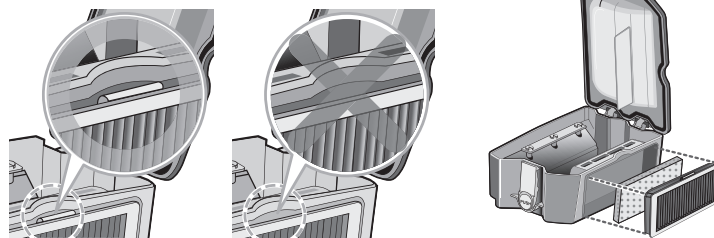

Tip

- In order to maintain the performance of the HOM-BOT, the HEPA filter should be cleaned with a cleaning brush or vacuum cleaner at least once a week, and should be washed under running water at least once a month.

CLEANING THE BRUSH

The brush, located on the bottom of the HOM-BOT, helps with the suction of foreign objects. Perform the following steps to clean the brush:

- 1** Lay a smooth cloth on the floor. Turn the HOM-BOT over and put the HOM-BOT on the cloth. Turn off the power supply before cleaning.

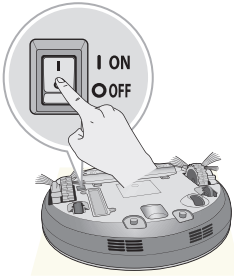

- 2** Separate the cover by pressing the fixing hook and pulling upward.

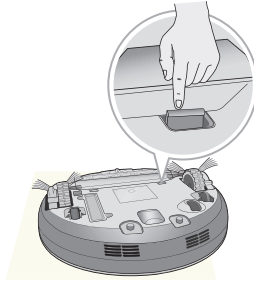

- 3** Wearing gloves turn the brush until the separation groove of the brush appears.

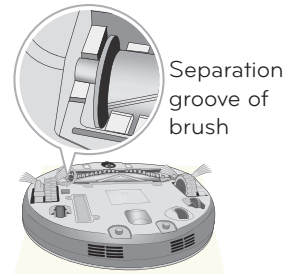

- 4** Grab the brush and remove by pulling it up.

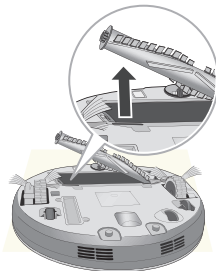

- 5** Clean the brush with a vacuum cleaner, scissors, etc.

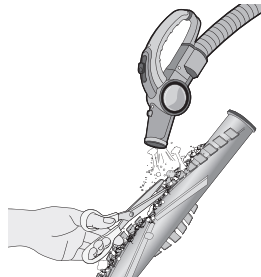

- 6** Insert the fixing hook on the side of the brush (marked with the square) by matching it to the fixing groove of the brush.

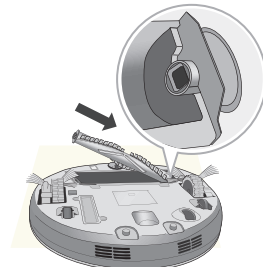

- 7** Insert the fixing hook on the opposite side of the brush (marked with a rounded rectangle) by matching it to the separation groove of the brush.

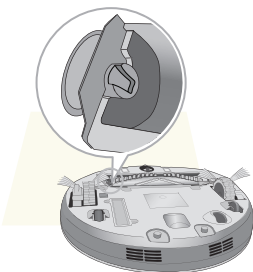

- 8** Align the cover with the fixing guides on the edge, by matching it to the fixing groove located on the main frame.

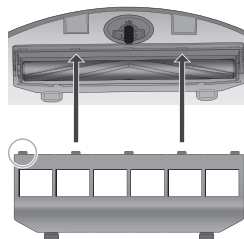

- 9** Close the cover by pressing it down until you hear a click from the fixing hook.
* NOTE: Please make sure that the side rotating brushes are not caught under the cover when refitting.

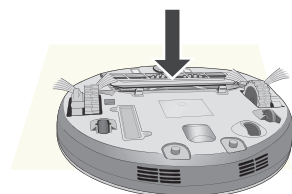

CLEANING THE SENSOR/CHARGING TERMINAL

There are sensors on the HOM-BOT that can detect obstacles, stairways and the home station for charging the battery. In order to maintain the performance of the HOM-BOT, regularly clean the sensors and charging terminal as follows:

1. Lay a smooth cloth on the floor, overturn the HOM-BOT and put it on the cloth.
2. Turn off the power switch on the bottom of the HOM-BOT. Injury can be caused by the activation of the HOM-BOT if the main power is not turned off.
3. Use a smooth cloth or cleaning brush to wipe the dust off each sensor and the charging terminal as described below.

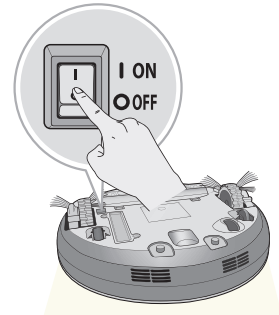

Receiving sensor of remote controller
Camera sensor

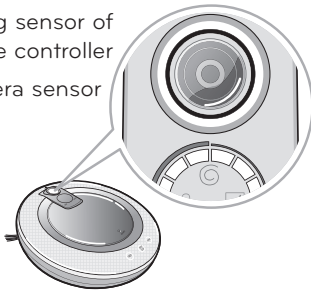

Obstacle detection sensor

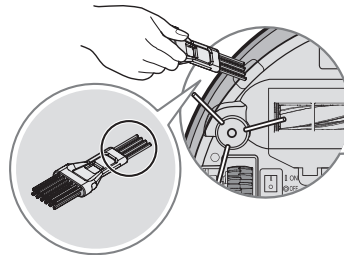
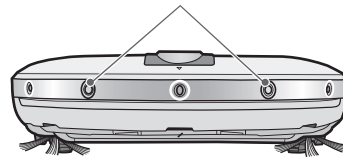

Cliff detection sensor

Charging terminal

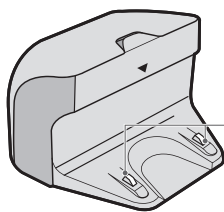

Charging terminal

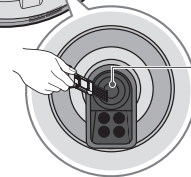

Lens



Tip

- Do not clean the HOM-BOT by directly spraying it with water, thinner, benzene, etc.
- Call the service center if the sensors or charging terminals are damaged. Sensor and terminal damage can cause the product to malfunction.

CLEANING THE SIDE BRUSH

Foreign objects/materials such as hair can easily adhere to the side brush. Remove such materials at least once a week.

If excessive amounts of foreign materials are stuck to the brush, there is a risk of damage to the brushes.

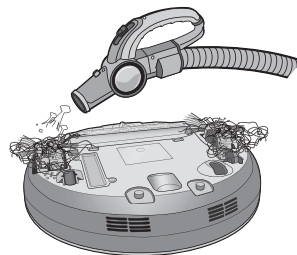

If the floor is rough or wall skirtings are frequently cleaned, the side brush may bend or become damaged. In this case, use the following method to straighten the side brush.

1. The following procedure is helpful in restoring deformed brushes.
2. Turn off the unit by pressing the START/STOP button on the HOM-BOT for two seconds.
3. Place the HOM-BOT at the end of a table to make cleaning the side brush easier. Make sure that the HOM-BOT is not in danger of falling.
4. Soak the side brush in warm water.
5. Press down on the side brush for about ten seconds so that it is completely submerged in the water.
6. Slowly wipe the side brush by sliding it through your hand.
7. Rotate the side brush and repeat steps 4-6 for each section of the brush.
8. Use the side brush only after it has completely dried.

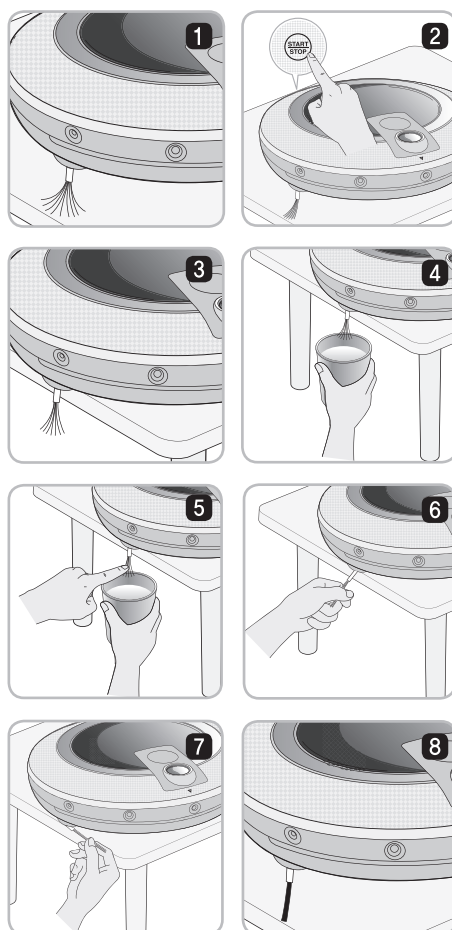

CLEANING THE ULTRA MICROFIBER MOP (Mop attachment sold separately)

To avoid odors, dirt and dust should be washed off the mop after it is used for cleaning. Follow these directions to wash the ultra microfiber mop:

1. Separate the ultra microfiber mop from the mop plate.

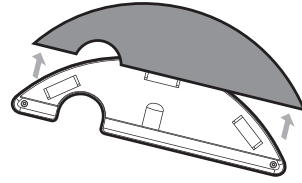

2. Carefully clean it with water.



3. Use the mop only after allowing it to dry completely in a sunny, well-ventilated area.

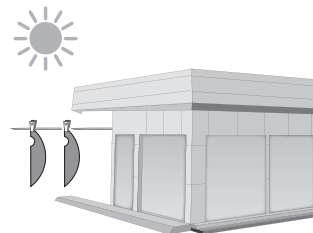

- Tip**
- To avoid product malfunction, only use the ultra microfiber mop provided with the HOM-BOT.
 - Additional microfiber mops can be purchased by visiting a nearby LG Electronics service center.

TROUBLESHOOTING

When the voice, "Please check the wheels", is announced.

If the unit becomes stuck or suspended and the wheels do not allow the unit move, the voice, "Please check the wheels", will be announced.

- Is a wheel trapped in the front door, balcony, stairway, etc?
 - ▶ Move the HOM-BOT on to the flat floor.



- Is any foreign material wound around the wheel?
 - ▶ Lay smooth cloth on the floor, overturn the HOM-BOT, and put it on the cloth. Remove foreign material by confirming the wheel.



TROUBLESHOOTING

When the voice, "Please check the dust bin", is announced

When an abnormality is detected with the dust bin, the voice, "Please check the dust bin", is announced.

- Is the dust bin fitted correctly?
 - ▶ Open the dust bin cover, and if check if the dust bin is actually fitted. the unit will not operate without the dust bin.
 - ▶ If the dust bin cover opened, close the cover before operating the unit.

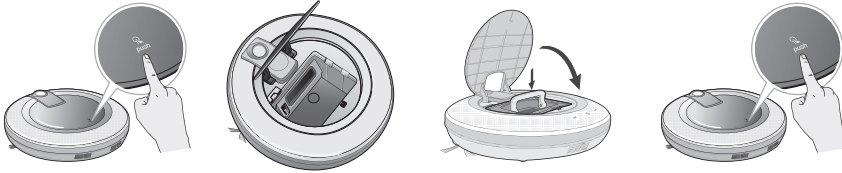

When the voice, "Battery is low", is announced.

When the battery is almost drained, the voice, "Battery is low", is generated.

- Initiate battery charging of HOM-BOT by moving it to the home station.
 - ▶ When attaching the HOM-BOT to the home station by matching both arrows of HOM-BOT and home station, charging will be started and the sound of charging start melody will be heard.

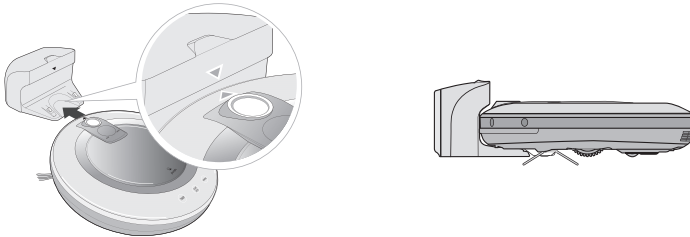

TROUBLESHOOTING

When you hear "Please check the brush"

When the HOM-BOT detects that the brush is not functioning properly, you will hear the message "Please check the brush."

Lay a smooth cloth on the floor, overturn the HOM-BOT, and place it on the cloth.

- The side brush is stuck.
 - ▶ Remove any foreign materials such as cables, thread or hair caught in the side brush or the brush.

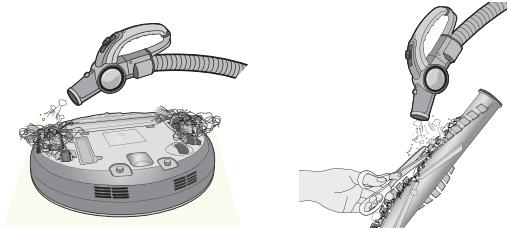

- ▶ Confirm the correct assembly of the brush by checking the separation groove of the brush.

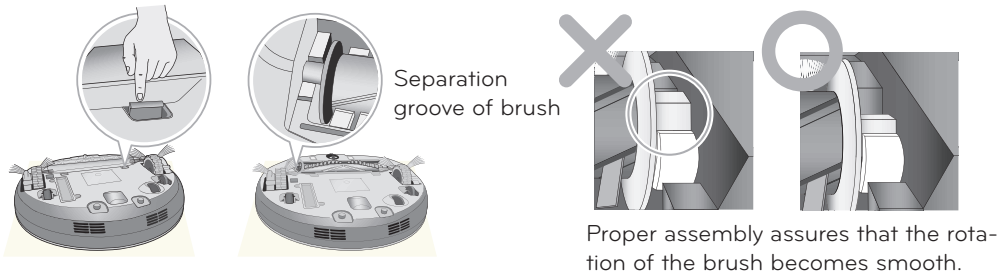

- The brush is making a loud, abnormal sound.
 - ▶ Remove the brush from the HOM-BOT and remove any foreign material from the brush.



※ For a more detailed description of this process, refer to the instructions on page 24.

BEFORE YOU CALL FOR SERVICE

Confirm before reporting the failure of HOM-BOT.

| Problem | Solutions (Reference page) |
|--|---|
| The HOM-BOT will not activate. | <ul style="list-style-type: none"> ▶ Confirm that the power switch is turned on. (page 14) ▶ Confirm that the battery has been charged. (page 17) |
| Movements or travel path are abnormal. | <ul style="list-style-type: none"> ▶ Carefully wipe the sensor with a smooth cloth. (page 25) ▶ If the ultra microfiber mop is attached, confirm that it is mounted properly. (page 21) ▶ Turn on the power switch off and on. |
| Suction power becomes weak. | <ul style="list-style-type: none"> ▶ Check whether there is foreign material blocking the suction port. (page 24) ▶ Empty the dust bin. (page 22) ▶ Clean the dust bin filter. (page 23) |
| Noise becomes louder. | <ul style="list-style-type: none"> ▶ Confirm that the dust bin has been fitted properly. ▶ Confirm that the dust bin filter has been fitted properly. (page 23) ▶ Check whether foreign material is caught in the brush. (page 24) |
| The HOM-BOT cannot be activated with the remote control. | <ul style="list-style-type: none"> ▶ Replace the remote control batteries. (page 11) ▶ Confirm that the control is within the coverage area of the main frame, which is up to 9.84 ft. (page 11) |
| The brush does not rotate. | <ul style="list-style-type: none"> ▶ Clean the brush. (page 24) ▶ Confirm that the brush has been fitted properly. (page 24) |
| The HOM-BOT will not charge. | <ul style="list-style-type: none"> ▶ Remove objects around the home station. (page 13) ▶ Confirm that the power supply is connected to the home station. (page 13) ▶ Wipe the charging terminal with a dry cloth. |
| The power supply automatically turns off. | This is not a failure. HOM-BOT has its own power saving function. If it is not used for ten minutes after the power supply is turned on, the power will automatically turn off. |
| The power supply cannot be turned on. | Check that the power switch on the underside is turned on. (Page 14) |

PRODUCT SPECIFICATIONS

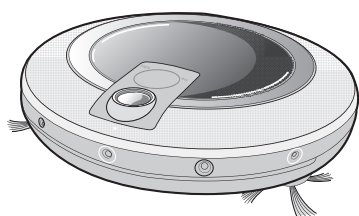

| Item/model | LG HOM-BOT LRV5900 |
|-------------------------------|--|
| External dimension | Φ 14.17 in X 3.54 in |
| Weight | 7lb |
| Power consumption | 18 W |
| Battery (fully charged) | DC 16.8 V |
| Maximum Traveling Velocity | 13.8 in/sec |
| Use time (1 time charging) | Approx. 75 minutes Based on general floor surface |
| Charging time | 3 hours |
| Main functions | Obstacle detection function Falling prevention function Timer cleaning function Error indication function Automatic, manual charging function Dry mop function (wiping) (option) Edge cleaning function Voice announcement function Map building function Spot cleaning function Spatial expansion cleaning function Zigzag cleaning function |

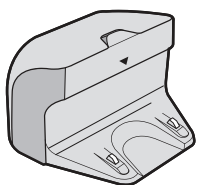

| Item/model | Home station VR591 |
|------------------------|-----------------------------|
| External dimension | 8.03 in X 6.22 in X 4.92 in |
| Rating | AC 120V, 60Hz |
| Output voltage/current | 17.1 V / 1.1 A |
| Power consumption | 23 W |

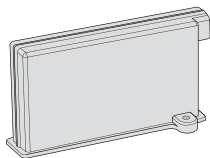

| Item/model | Battery EAC60766105 |
|-----------------------------------|-----------------------------|
| Size | 4.76 in X 2.44 in X 1.89 in |
| Type | Li-ion polymer type |
| Number of Batteries | 1 EA |
| Electrical Rating of Battery Pack | 14.8 Vdc, 1900 mA·H |

REFERENCE ITEMS

Open source software notice

The following GPL executables and LGPL libraries used in this product are subject to the GPL/LGPL License Agreements:

GPL EXECUTABLES:

Linux kernel 2.6, bash, busybox, gdb, mtd-utils, u-boot, module-init-tools, procps, wireless-tools

LGPL LIBRARIES:

glibc

LG Electronics offers to provide source code to you on CD-ROM for a charge covering the cost of performing such distribution, such as the cost of media, shipping and handling upon e-mail request to LG Electronics at:

opensource@lge.com

This offer is valid for a period of three (3) years from the date of the distribution of this product by LG Electronics.

You can obtain a copy of the GPLv2.0, LGPLv2.1 licenses from
<http://www.gnu.org/licenses/old-licenses/gpl-2.0.html>,
<http://www.gnu.org/licenses/old-licenses/lgpl-2.1.html> .

Also you can obtain the translation of GPLv2.0, LGPLv2.1 licenses from
<http://www.gnu.org/licenses/old-licenses/gpl-2.0-translations.html>,
<http://www.gnu.org/licenses/old-licenses/lgpl-2.1-translations.html>.

This product includes other open source software.

- OpenCV : Copyright © 2000, 2001, Intel Corporation.
- openssl:
 - cryptographic software written by Eric Young (eay@cryptsoft.com).
 - software written by Tim Hudson (tjh@cryptsoft.com).
 - software developed by the OpenSSL Project for use in the OpenSSL Toolkit. (<http://www.openssl.org>)

All rights reserved.

REFERENCE ITEMS

This software is provided by the copyright holders and contributors "as is" and any express or implied warranties, including, but not limited to, the implied warranties of merchantability and fitness for a particular purpose are disclaimed. In no event shall the Intel Corporation or contributors be liable for any direct, indirect, incidental, special, exemplary, or consequential damages (including, but not limited to, procurement of substitute goods or services; loss of use, data, or profits; or business interruption) however caused and on any theory of liability, whether in contract, strict liability, or tort (including negligence or otherwise) arising in any way out of the use of this software, even if advised of the possibility of such damage.

MEMO



Disposal of waste batteries/accumulators

1. When this crossed-out wheeled bin symbol is attached to batteries/accumulators of Your product it means they are covered by European Directive 2006/06/EC.
2. This symbol may be combined with chemical symbols for mercury(Hg), cadmium(Cd) or lead(Pb) if the battery Contains more than 0.0005% of mercury, 0.002% of cadmium or 0.004% of lead.
3. All batteries/accumulators should be disposed separately from the municipal waste stream via designated collection facilities appointed by the government or the local authorities.
4. The correct disposal of Your old batteries/accumulators will help to prevent potential negative consequences for the environment, animal and human health.
5. For more detailed information about disposal of Your old batteries/accumulators, please contact Your city office, waste disposal service or the shop where You purchased the product.



Disposal of your old appliance

1. When this crossed-out wheeled bin symbol is attached to a product it means the product is covered by the European Directive 2002/96/EC.
2. All electrical and electronic products should be disposed of separately from the municipal waste stream via designated collection facilities appointed by the government or the local authorities.
3. The correct disposal of your old appliance will help prevent potential negative consequences for the environment and human health.
4. For more detailed information about disposal of your old appliance, please contact your city office, waste disposal service or the shop where you purchased the product.