

Model	MA3281T.ASSRLAP		
Language	English		
Page	68	Color(cover/body)	1/1
Material	모조 80g	Size(W*H)	A5(210X148mm)
Date	2012.08.24	Designer	Garam
Part No.	MFL65219805	Description	Manual,Owners

					
					
					
					
					
					
					
					
					
	P.50, 54, 56 문구 수정(호주법인 Confirm수정 사항임)		12.08.29	최진용	김남형
기호	변 경 사 항	시방번호	년 월 일	서명	승인

* Owner's Manual 시방이력 관리



OWNER'S MANUAL

LIGHTWAVE OVEN "Steam SolarDOM"

Please read this owner's manual thoroughly before operating.

The manufacturer is not liable for any problems caused by the user's failure to observe these instructions.

MA3281T



MFL65219805

www.lg.com

Contents

How the Microwave Function Works

Microwaves are a form of energy similar to radio and television waves and ordinary daylight. Normally, microwaves spread outwards as they travel through the atmosphere and disappear without effect. This oven, however, has a magnetron which is designed to make use of the energy in microwaves. Electricity, supplied to the magnetron tube, is used to create microwave energy.

These microwaves enter the cooking area through openings inside the oven. A tray is located inside the oven. Microwaves cannot pass through metal walls of the oven, but they can penetrate such materials as glass, porcelain and paper, the materials out of which microwave-safe cooking dishes are constructed.

Microwaves do not heat cookware, though cooking vessels will eventually get hot from the heat generated by the food.

A very safe appliance

Your SolarDOM oven, is one of the safest of all home appliances. When the door is opened, the oven automatically stops producing microwaves. Microwave energy is converted completely to heat when it enters food, leaving no "left over" energy to harm you when you eat your food.

Contents	2
Important safety instructions	3 ~ 16
Precautions	17
Unpacking & Installing	18 ~ 19
Control Panel	20
Setting the Clock	21
Child Lock	22
Microwave (Micro) Power Cooking	23
Micro Power Level	24
Grill Cooking	25
Grill Combi Cooking	26
Convection Preheat	27
Convection Cooking	28
Convection Combi Cooking	29
For Steam+ cooking	30
Micro Power Steam+ Cooking	31 ~ 32
Convection Steam+ Cooking	33 ~ 34
Steam+	35 ~ 36
Auto Cooking	37 ~ 45
Steam+ Auto Cooking	46 ~ 51
Defrost	52
Defrosting Guide	53
Defrost Steam+	54
Defrost Steam+ Guide	55
Steam Multi clean	56
Quick Start	57
More or Less Cooking	58
How To Clean	59
Microwave - safe Utensils	60
Food characteristics & Microwave cooking	61 ~ 62
Questions & Answers	63
Technical Specifications	64

Please keep for future reference. Read and follow all instructions before using your oven to prevent the risk of fire, electric shock, personal injury, or damage when using the oven. This guide does not cover all possible conditions that may occur. Always contact your service agent or manufacturer about problems that you do not understand.

Important Safety **Instructions**



This is the safety alert symbol. This symbol alerts you to potential hazards that can cause death or serious injury to you and others. All safety messages will follow the safety alert symbol and either the word “WARNING” or “CAUTION”. These word means :

⚠ WARNING: This symbol will alert you to hazards or unsafe practices which could cause serious bodily harm or death.

⚠ CAUTION: This symbol will alert you to hazards or unsafe practices which could cause bodily injury or property damage.

Important Safety **Instructions**

Please keep for future reference. Read and follow all instructions before using your oven to prevent the risk of fire, electric shock, personal injury, or damage when using the oven. This guide does not cover all possible conditions that may occur. Always contact your service agent or manufacturer about problems that you do not understand.

⚠ WARNING

1. Do not attempt to tamper with, or make any adjustments or repairs to the door, door seals, control panel, safety interlock switches or any other part of the oven, which involves the removal of any cover which gives protection against exposure to microwave energy. Do not operate the oven, if the door seals and adjacent parts of the microwave oven are faulty. Repairs should only be undertaken by a qualified service technician.

➡ Unlike other appliances, the microwave oven is high-voltage and high-current equipment. Improper use or repair could

result in harmful exposure to excessive microwave energy or an electric shock.

2. Do not use the oven for the purpose of dehumidification. (ex. Operating the microwave oven with wet newspapers, clothes, toys, electric devices, pets or children inside.)

➡ It can be the cause of serious damage and safety risks causing fire, burns, electric shock or death.

Please keep for future reference. Read and follow all instructions before using your oven to prevent the risk of fire, electric shock, personal injury, or damage when using the oven. This guide does not cover all possible conditions that may occur. Always contact your service agent or manufacturer about problems that you do not understand.

Important Safety **Instructions**

⚠ WARNING

- 3. The appliance and its accessible parts become hot during use. Care should be taken to avoid touching heating elements. Children less than 8 years of age shall be kept away unless continuously supervised.**
- 4. The appliance is not intended for use by young children or infirm persons. Only allow children to use the oven without supervision when adequate instructions have been given so that the child is able to use the oven in a safe way and understands the hazards of improper use.**
- ➡ Improper use may cause damage and safety concerns such as a fire, an electric shock or burns.**
- 5. Accessible parts may become hot during use. Young children should be kept away.**
 - ➡ Failing to do so could cause serious burns.**
- 6. Liquids or other foods must not be heated in sealed containers since they are liable to explode. Remove the plastic wrapping from food before cooking or defrosting. Note though that in some cases food should be covered with plastic film, for heating or cooking.**
 - ➡ Never heat bottles or fluid containers with the lids fitted as they will explode.**

Important Safety **Instructions**

Please keep for future reference. Read and follow all instructions before using your oven to prevent the risk of fire, electric shock, personal injury, or damage when using the oven. This guide does not cover all possible conditions that may occur. Always contact your service agent or manufacturer about problems that you do not understand.

WARNING

- 7. When the appliance is operated in the combination mode, children should only use the oven under adult supervision due to the temperatures generated.**

Please keep for future reference. Read and follow all instructions before using your oven to prevent the risk of fire, electric shock, personal injury, or damage when using the oven. This guide does not cover all possible conditions that may occur. Always contact your service agent or manufacturer about problems that you do not understand.

Important Safety **Instructions**

CAUTION

1. You cannot operate your oven with the door open due to the safety interlocks built into the door mechanism. It is important not to tamper with the safety interlock.

➡ It could result in harmful exposure to excessive microwave energy. (Safety interlocks automatically switch off any cooking activity when the door is opened.)

2. Do not place any object (such as kitchen towel, napkin, etc.) between the oven front face and the door or allow food or cleaner residue to accumulate on sealing surfaces.

➡ It could result in harmful exposure to excessive microwave energy.

3. Do not operate your oven if it is damaged. It is particularly important that the oven door closes properly and that there is no damage to the: (1) door(bent), (2) hinges and latches (broken or loosened), (3) door seals and sealing surfaces.

➡ It could result in harmful exposure to excessive microwave energy.

Important Safety

Instructions

Please keep for future reference. Read and follow all instructions before using your oven to prevent the risk of fire, electric shock, personal injury, or damage when using the oven. This guide does not cover all possible conditions that may occur. Always contact your service agent or manufacturer about problems that you do not understand.

CAUTION

4. Please ensure cooking times are correctly set. Small amounts of food require shorter cooking or heating time.

➡ The over cooking may result in the food catching fire and subsequent damage to your oven.

Note:

Excessive cooking times and temperatures can cause a build up of condensation behind the door glass. The settings should readjusted to reduce either the cooking time or power. The condensation will disappear shortly after the cooking has stopped.

5. When heating liquids, e.g. soups, sauces and beverages in your microwave oven,

* **Avoid using straight sided containers with narrow necks.**

* **Do not overheat.**

* **Stir the liquid before placing the container in the oven and again halfway through the heating time.**

* **After heating, allow to stand in the oven for a short time, stir them again carefully and check the temperature of them before consumption to avoid burns (especially, contents of feeding bottles and baby food jars).**

➡ Be careful when handling the container. Microwave heating of

Please keep for future reference. Read and follow all instructions before using your oven to prevent the risk of fire, electric shock, personal injury, or damage when using the oven. This guide does not cover all possible conditions that may occur. Always contact your service agent or manufacturer about problems that you do not understand.

Important Safety **Instructions**

⚠ CAUTION

beverages can result in delayed eruptive boiling without evidence of bubbling.

This could result in a sudden boil over of the hot liquid.

6. An exhaust outlet is located on top or bottom or side of the oven. Don't block the outlet.

- ➔ It could result in damage to your oven and poor cooking results.

Never heat bottles, fluid or beverage containers with the lids fitted. Doing so will cause them to explode.

7. Do not operate the oven when empty. It is best to leave a glass of water in the oven when not in use. The water will safely absorb all microwave energy, if the oven is accidentally started.

- ➔ Improper use could result in damage to your oven.

8. Do not cook food wrapped in paper towels, unless your cook book contains instructions for the food you are cooking. And do not use newspaper in place of paper towels for cooking.

- ➔ Improper use can be the cause of an explosion or a fire.

Important Safety

Instructions

Please keep for future reference. Read and follow all instructions before using your oven to prevent the risk of fire, electric shock, personal injury, or damage when using the oven. This guide does not cover all possible conditions that may occur. Always contact your service agent or manufacturer about problems that you do not understand.

CAUTION

9. Do not use wooden containers and ceramic containers which have metallic (e.g. gold or silver) inlays. Always remove metal twist ties. Check the utensils are suitable for use in microwave ovens before use.

➤ They may heat-up and char. Especially metal objects in the oven may arc, which can cause serious damage.

10. Do not use recycled paper products.

➤ They may contain impurities which may cause sparks and/or fires when used in cooking.

Never use Aluminium foil during microwave cooking or leave metallic

eating or cooking utensils inside the oven during operation

11. Do not rinse the tray and rack by placing it in water just after cooking. This may cause breakage or deformation.

➤ Improper use could result in damage to your oven.

12. Be certain to place the oven so the front of the door is 8 cm or more behind the edge of the surface on which it is placed, to avoid accidental tipping of the appliance.

➤ Improper use could result in bodily injury and oven damage.

Please keep for future reference. Read and follow all instructions before using your oven to prevent the risk of fire, electric shock, personal injury, or damage when using the oven. This guide does not cover all possible conditions that may occur. Always contact your service agent or manufacturer about problems that you do not understand.

Important Safety **Instructions**

⚠ CAUTION

13. Before cooking, pierce the skin of potatoes, apples or any such fruit or vegetable.

➡ If left unpierced, they could burst.

14. Do not cook eggs in their shell. Eggs in their shell and whole hard-boiled eggs should not be heated in microwave ovens since they may explode, even after microwave heating has ended.

➡ Pressure will build up inside the egg which will burst.

15. Do not attempt deep fat frying in your oven.

➡ This could result in a sudden boil over of the hot liquid and cause serious damage or fire.

16. If smoke is observed (or emitted), switch off or disconnect the oven from the power supply and keep the oven door closed in order to stifle any flames.

➡ Failing to do so can result in serious damage and safety risks such as fire and electric shock.

Important Safety

Instructions

Please keep for future reference. Read and follow all instructions before using your oven to prevent the risk of fire, electric shock, personal injury, or damage when using the oven. This guide does not cover all possible conditions that may occur. Always contact your service agent or manufacturer about problems that you do not understand.

CAUTION

17. When food is heated or cooked in disposable containers of plastic, paper or other combustible materials, keep an eye on the oven due to the possibility of ignition and check it frequently.

➔ Disposable containers may weaken and crack due to deterioration which may cause liquids to leak and cause damage or fire.

18. The temperature of accessible surfaces may be high when the appliance is operating. Do not touch the oven door, outer cabinet, rear cabinet, oven cavity, accessories and dishes during grill mode, convection mode and auto cook

operations, before clearing make sure they are not hot.

➔ As they will become hot, there is the danger of a burn unless wearing thick oven gloves.

This oven is not suitable for a built in application. It is intended for bench top application. Installation in a closed cabinet will compromise airflow and may cause fire or damage to the oven and cabinetry.

Please keep for future reference. Read and follow all instructions before using your oven to prevent the risk of fire, electric shock, personal injury, or damage when using the oven. This guide does not cover all possible conditions that may occur. Always contact your service agent or manufacturer about problems that you do not understand.

Important Safety **Instructions**

⚠ CAUTION

19. The oven should be cleaned regularly and any food deposits removed.

➡ Failure to maintain the oven in a clean condition could lead to deterioration of the surface that could adversely affect the life of the appliance and possibly result in a hazardous situation.

20. Only use the temperature probe recommended for this oven (for appliances having a facility to use a temperature-sensing probe).

➡ You can not ascertain that the temperature is accurate with an unsuitable temperature probe.

21. During use of heating element cooking functions, the appliance becomes hot. Care should be taken to avoid touching heating elements inside the oven.

➡ Failing to do so will cause serious burns.

22. Follow exact directions given by each manufacturer for their popcorn product. Do not leave the oven unattended while the corn is being popped. If corn fails to pop after the suggested times, discontinue cooking. Never use a brown paper bag for popping corn. Never attempt to pop leftover kernels.

➡ Overcooking could result in the corn catching fire.

Important Safety

Instructions

Please keep for future reference. Read and follow all instructions before using your oven to prevent the risk of fire, electric shock, personal injury, or damage when using the oven. This guide does not cover all possible conditions that may occur. Always contact your service agent or manufacturer about problems that you do not understand.

CAUTION

23. This appliance must be earthed.

The wires in this mains lead are colored in accordance with the following codes

BLUE ~ Neutral

BROWN ~ Live

GREEN & YELLOW ~ Earth

This unit must only be connected to a 240v 50Hz mains supply via the connected 10amp plug .

If the supply cord is damaged, it must be replaced by the manufacturer or its service agent or a similarly qualified person in order to avoid a hazard.

➤ Improper use may cause serious damage and electric shock.

24. Do not use harsh abrasive cleaners or sharp metal scrapers to clean the oven door glass.

➤ They can scratch the surface, which may result in shattering of the glass.

25. This oven should not be used for commercial catering purposes.

➤ Improper use could result in damage to your oven.

26. The mains plug and its connection to the power outlet should be easily accessible in the event that the power needs to be switched off immediately.

Please keep for future reference. Read and follow all instructions before using your oven to prevent the risk of fire, electric shock, personal injury, or damage when using the oven. This guide does not cover all possible conditions that may occur. Always contact your service agent or manufacturer about problems that you do not understand.

Important Safety **Instructions**

CAUTION

- 27. This appliance is not intended for use by persons (including children) with reduced physical, sensory or mental capabilities, or lack of experience and knowledge, unless they have been given supervision or instruction concerning use of the appliance by a person responsible for their safety.**
- 28. (Young)Children should be supervised to ensure that they do not play with the appliance.**

- 29. The appliance is not intended to be operated by means of an external timer or separate remote-control system.**
- 30. This appliance can be used by children aged from 8 years and above and persons with reduced physical, sensory or mental capabilities or lack of experience and knowledge if they have been given supervision or instruction concerning use of the appliance in a safe way and understand the hazards involved. Children shall not play with the appliance.
Cleaning and user maintenance shall not be undertaken by children without supervision.**

Important Safety

Instructions

Please keep for future reference. Read and follow all instructions before using your oven to prevent the risk of fire, electric shock, personal injury, or damage when using the oven. This guide does not cover all possible conditions that may occur. Always contact your service agent or manufacturer about problems that you do not understand.

CAUTION

- 31. Where shelves are fitted, please follow removal and refitting instructions when cleaning the interior of the oven.**
- 32. Never heat up feeding bottles or food jars with the lids on. Stir all fluids as they heat and always check the temperature of the fluids before consuming to avoid burns.**
- 33. Do not use steam cleaners or chemical oven cleaners to clean the internal cavity. Always clean the oven along with any spill overs after each use with warm water and a soft cloth.**

Precautions to avoid possible exposure to excessive microwave energy.

You cannot operate your oven with the door open due to the safety interlocks built into the door mechanism. These safety interlocks automatically switch off any cooking activity when the door is opened; which in the operation of microwave function could result in harmful exposure to microwave energy.

It is important not to tamper with the safety interlocks.

Do not place any object between the oven front face and the door or allow food or cleaner residue to accumulate on sealing surfaces.

Do not operate your oven if it is damaged. It is particularly important that the oven door closes properly and that there is no damage to the: (1) door(bent), (2) hinges and latches (broken or loosened), (3) door seals and sealing surfaces.

Your oven should not be adjusted or repaired by anyone except qualified service personnel.

Note:

Excessive cooking times and temperatures can cause a build up of condensation behind the door glass.

The settings should readjusted to reduce either the cooking time or power.

The condensation will disappear shortly after the cooking has stopped.

WARNING

Please ensure cooking times are correctly set as over cooking may result in the FOOD catching fire and subsequent damage to your oven.

When heating liquids, e.g. soups, sauces and beverages in your oven with microwave function, delayed eruptive boiling can occur without evidence of bubbling. This could result in a sudden boil over of the hot liquid. To prevent this possibility the following steps should be taken:

- 1 Avoid using straight sided containers with narrow necks.
- 2 Do not overheat.
- 3 Stir the liquid before placing the container in the oven and again halfway through the heating time.
- 4 After heating, allow to stand in the oven for a short time, stir or shake them(especially the contents of feeding bottles and baby food jars) again carefully and check the temperature of them before consumption to avoid burns (especially, contents of feeding bottles and baby food jars).
Be careful when handling the container.

WARNING

Always allow food to stand after being cooked by microwaves and check the temperature of them before consumption. Especially contents of feeding bottles and baby food jars.

Unpacking & Installing

By following the basic steps on these two pages you will be able to quickly check that your oven is operating correctly. Please pay particular attention to the guidance on where to install your oven. When unpacking your oven make sure you remove all accessories and packing. Check to make sure that your oven has not been damaged during delivery. Do not use the oven if it is damaged.

- 1** Unpack your oven and place it on a flat level surface.

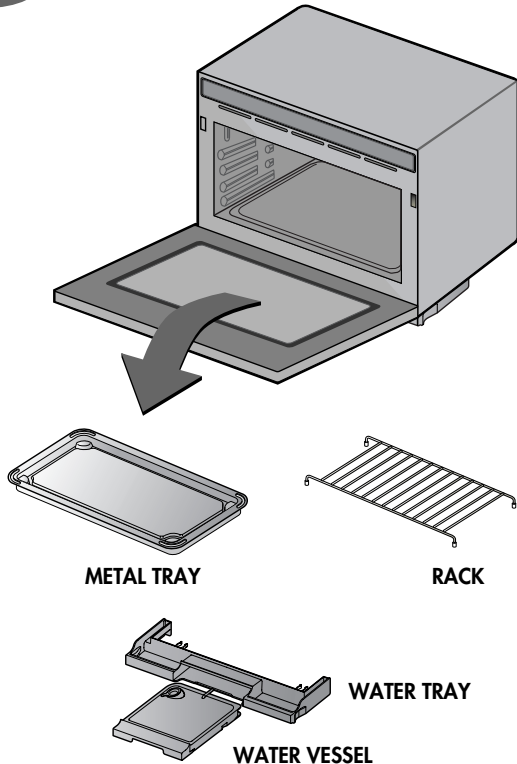

- 2** Place the oven on a level bench top surface of your choice with more than 85cm height but make sure there is at least 20cm of space on the top and 10cm at the rear for proper ventilation. The front of the oven should be at least min. 8cm/max. 22cm from the edge of the surface to prevent tipping. An exhaust outlet is located on the underside of the oven and can emit very hot air temperatures. If the bench top is made of timber or has a veneered finish, a shield must be placed between the oven and the bench top to avoid it from being damaged or discoloured. Blocking the outlet can damage the oven.

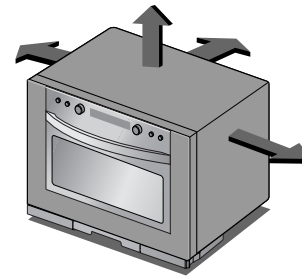

- * THIS OVEN SHOULD NOT BE USED FOR COMMERCIAL CATERING PURPOSES.**
- * THIS OVEN CAN NOT BE USED AS BUILT-IN TYPE.**
- * THIS OVEN IS INTENDED FOR DOMESTIC INDOOR HOME USE. IT SHOULD NOT BE USED FOR MOBILE APPLICATIONS.**

3 Plug your oven into a standard household socket. Make sure your oven is the only appliance connected to the socket. **If your oven does not operate properly, unplug it from the electrical socket and then plug it back in.**

4 Open your oven door by pulling the **DOOR HANDLE**. Place the **RACK** inside the oven.

5 Fill a **microwave safe container** with 300 ml (1/2 pint) of water. Place on the rack on the oven bottom surface and close the oven door. If you have any doubts about what type of container to use please refer to page 60.

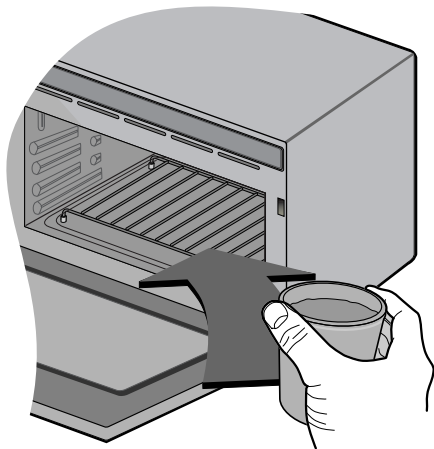

6 Press the **STOP/CLEAR** (⏹) button, and press the **ENTER/START/Q-START** (✓/⏻) button one time to set 30 seconds of cooking time.



7 The **DISPLAY** will count down from 30 seconds. When it reaches 0 it will emit an audible beep until the door is opened or the STOP/CLEAR button is pressed. Open the oven door and test the temperature of the water. If your oven is operating the water should be warm. **Be careful when removing the container it may be hot.**



YOUR OVEN IS NOW INSTALLED

Control Panel

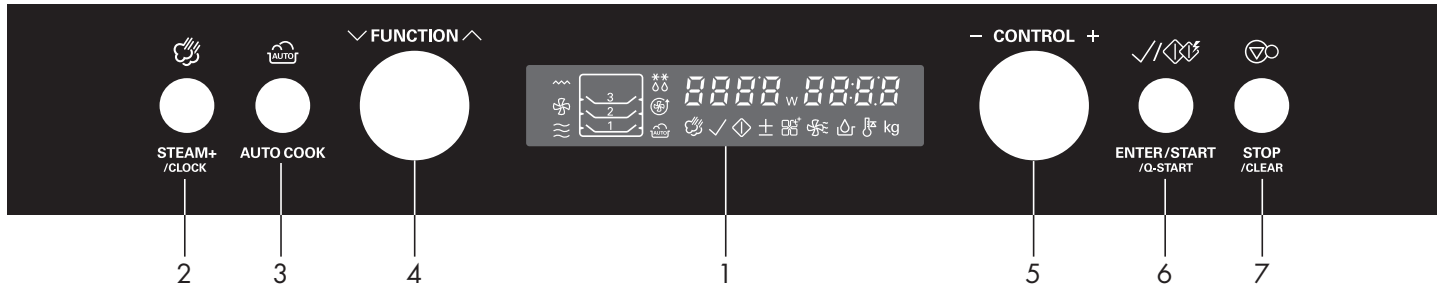

1. DISPLAY WINDOW: This will show the time of day, cooking time, power level and cooking categories.

2. STEAM+ /CLOCK (🌀)

- **STEAM+:** You can add steam.
- **CLOCK:** You can set the time of day.

3. AUTO COOK (🍲)

- **AUTO COOK:** Auto Cook allows you to cook popular foods quickly by selecting the food type and the weight of the food.

4. FUNCTION SELECT: You can select cooking categories.

5. CONTROL:

- You can set cooking times, temperature, weight and cooking categories.
- While cooking with auto and manual function, you can lengthen or shorten the cooking time at any point by turning the dial (except defrost mode).

6. ENTER/START /Q-START (✓/⚡):

- In order to start cooking in microwave mode, press button one time.
- The quick start feature allows you to set 30 seconds intervals of HIGH power cooking with a touch of the quick start button.

7. STOP /CLEAR (⏹): Stops and clears all entries except time of day.

Setting the Clock

You can set either 12 hour clock or 24 hour clock.

In the following example I will show you how to set the time for 10:30 when using the 24 clock.

Make sure that you have removed all packaging from your oven.



When your oven is plugged in for the first time or when power resumes after a power cut, a '0' will be shown in the display; you will have to reset the clock.

If the clock (or display) shows any strange looking symbols, unplug your oven from the electrical socket and plug it back in and reset the clock.

Make sure that you have correctly installed your oven as described earlier in this book.

Press **STOP/CLEAR** ().

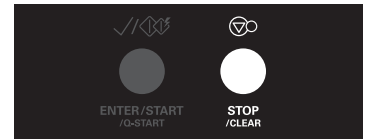

Press **STEAM+/CLOCK** () for 2sec.

(If you want to use a 12 hour clock, Turn **CONTROL dial**.
If you want to change the 12/24Hr option after setting the clock, you will need to unplug the oven and plug it back in.)

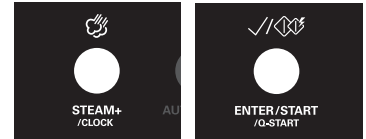

Press **ENTER/START/Q-START** ().

Turn the **CONTROL dial** until display shows "10:00".

Press **ENTER/START/Q-START** () for hour confirmation

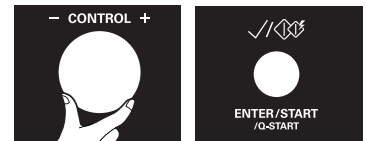

Turn the **CONTROL dial** until display shows "10:30".

Press **ENTER/START/Q-START** ().

The clock starts counting.

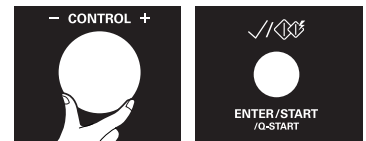

Child Lock



Your oven has a safety feature that prevents accidental running of the oven. Once the child lock is set, you will be unable to use any functions and no cooking can take place. However your child can still open the oven door.

Press **STOP/CLEAR** (🛑).

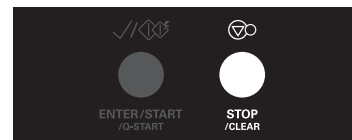

Press and hold **STOP/CLEAR** (🛑) until "L" appears on the display and BEEP sounds.

The **CHILD LOCK** is now set.

The time will disappear on the display but will reappear on the display a few seconds later.



If any button is pressed, "L" will appear on the display



To cancel **CHILD LOCK** press and hold **STOP/CLEAR** (🛑) until "L" disappears.

You will hear BEEP when it's released.

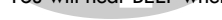

Microwave (Micro) Power Cooking

In the following example I will show you how to cook food on 450W power for 5 minutes.



Your oven has five microwave Power settings. High power is automatically selected and turning the Control dial will select a different power level.

POWER	
HIGH	700 W
MEDIUM HIGH	450 W
MEDIUM	300 W
DEFROST	
MEDIUM LOW	180 W
LOW	90 W

1 Make sure that you have correctly installed your oven as described earlier in this book.

Press **STOP/CLEAR** ().

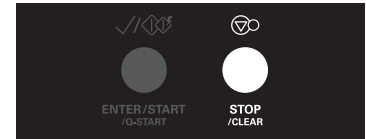

2 Turn the **FUNCTION** selection dial to select **Microwave**.

The following indication is displayed: " ≈ "



3 Turn the **CONTROL** dial until display shows "450W".

Press **ENTER/START/Q-START** () for power confirmation.

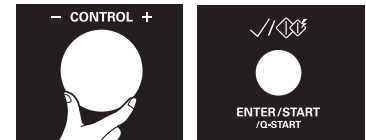

4 Turn the **CONTROL** dial until display shows "5:00".

Press **ENTER/START/Q-START** ().

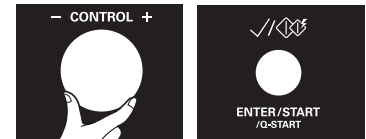

Micro Power Level

This oven is equipped with 5 power levels to give you maximum flexibility and control over cooking. The table below shows the examples of food and their recommended cooking power levels for use with this oven.

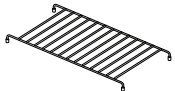
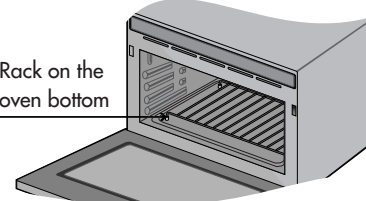
POWER LEVEL	OUTPUT	USE	ACCESSORY
HIGH	700W	<ul style="list-style-type: none"> * Boil Water * Brown minced beef * Cook poultry pieces, fish, vegetables * Cook tender cuts of meat 	Rack  * Rack Location 
MEDIUM HIGH	450W	<ul style="list-style-type: none"> * All reheating * Roast meat and poultry * Cook mushrooms and shellfish * Cook foods containing cheese and eggs 	
MEDIUM	300W	<ul style="list-style-type: none"> * Bake cakes and scones * Prepare eggs * Cook custard * Prepare rice, soup 	
DEFROST/ MEDIUM LOW	180W	<ul style="list-style-type: none"> * All thawing * Melt butter and chocolate * Cook less tender cuts of meat 	
LOW	90W	<ul style="list-style-type: none"> * Soften butter & cheese * Soften ice cream * Raise yeast dough 	



Note:

Always place opened feeding bottles directly on the tray on Level 1 when heating. Do not use the metal rack when heating bottles. Doing so can deform the base of the bottles.

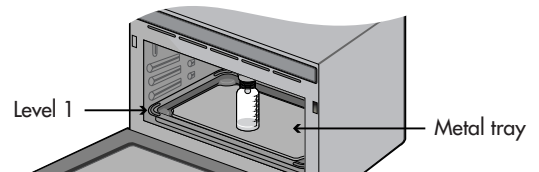

Grill Cooking

In the following example I will show you how to use the Grill to cook some food for 12 minutes.



This feature will allow you to brown and crisp food quickly.

The rack and Metal tray must be used during grill cooking.

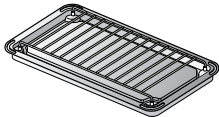

* Tray Location

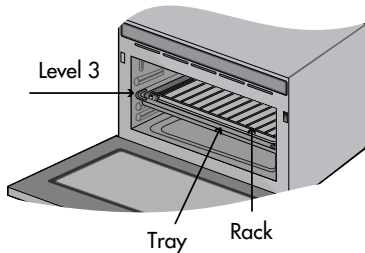

Press **STOP/CLEAR** (🔄).

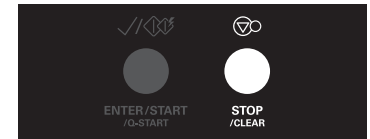

Turn the **FUNCTION selection dial** to select **Grill**.

The following indication is displayed: " ~ ~ ~ "



Turn the **CONTROL dial** until display shows "12:00".



Press **ENTER/START/Q-START** (✓/🔥).

After cooking you must wear heat proof oven gloves to take metal tray out of the oven as the tray and its contents will be very hot.



Grill combi Cooking

In the following example I will show you how to programme your oven with micro power 300W and grill for a cooking time of 25 minutes.

Your oven has a combination cooking feature which allows you to cook food with the heater and microwave function. This generally means it takes less time to cook your food.

You can set four levels of microwave power (90W, 180W, 300W and 450W) in grill combi mode.

The rack and Metal tray must be used during grill combi. cooking.

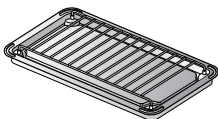

* Tray Location

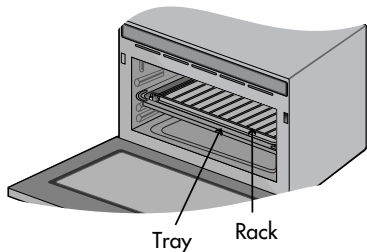

Press **STOP/CLEAR** (🛑).



Turn the **FUNCTION** selection dial to select **Grill Combi**.

The following indications are displayed: " ≈ ", " ≈ ≈ ".

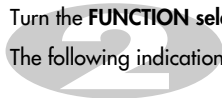

Turn the **CONTROL** dial until display shows "300W".

Press **ENTER/START/Q-START** (✓/🌀) for power confirmation.

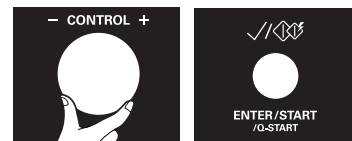

Turn the **CONTROL** dial until display shows "25:00".



Press **ENTER/START/Q-START** (✓/🌀).

After cooking you must wear heat proof oven gloves to take metal tray out of the oven as the tray and its contents will be very hot.

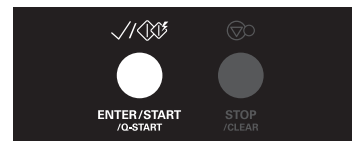

Convection Preheat

In the following example I will show you how to preheat the oven to a temperature of 200°C.



The convection oven has a temperature range from 40deg C to 230deg C. Smaller increments start from 100deg to 230deg C (180°C is automatically set when convection mode is selected).

The oven has a ferment function of 40°C. You may need to wait until the oven is cool because you cannot use the ferment function if the oven temperature is over 40°C.

Your oven will take a few minutes to reach the selected temperature.

Once it has reached correct temperature, your oven will BEEP to let you know that it has reached the correct temperature.

Then place your food in your oven: then press the START button to start cooking.

Press **STOP/CLEAR** ().



Turn the **FUNCTION** selection dial to select **Conv.**

The following indication is displayed: "  "



Turn the **CONTROL** dial until display shows "200°C".

Press **ENTER/START/Q-START** () for temperature confirmation.



Press **ENTER/START/Q-START** ().

Preheating will be started and will show " Pr-H".

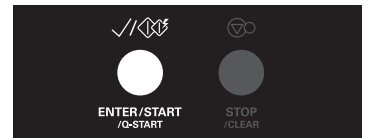
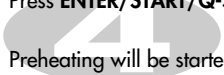

Convection Cooking

In the following example I will show you how to preheat the oven first, then cook food at a temperature of 230°C for 50 minutes.



If you do not set a temperature your oven will automatically select 180°C, the cooking temperature can be changed by turning the **Control dial**.

The Metal tray must be used during convection cooking.

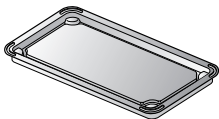

* Tray Location

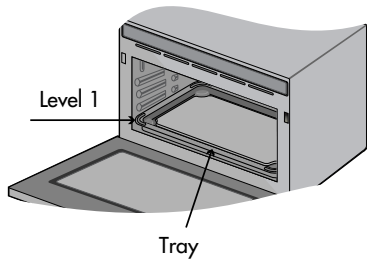

Press **STOP/CLEAR** ().



Turn the **FUNCTION** selection dial to select **Conv.**

The following indication is displayed: "  "



Turn the **CONTROL** dial until display shows "230°C".

Press **ENTER/START/Q-START** () for temperature confirmation.

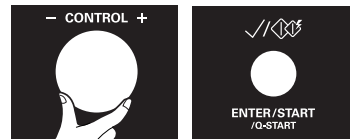

Turn the **CONTROL** dial until display shows "50:00".



Press **ENTER/START/Q-START** ().

When cooking you can increase or decrease cooking times by turning the **CONTROL** dial.



Convection combi

Cooking

In the following example I will show you how to programme your oven with micro power 300W and at a temperature of 200°C for a cooking time of 25 minutes.



You can set four kinds of micro power level (90W, 180W, 300W and 450W) in convection combi mode.

The rack and Metal tray must be used during Convection combi. cooking.

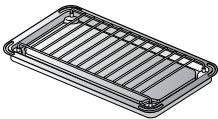

* Tray Location

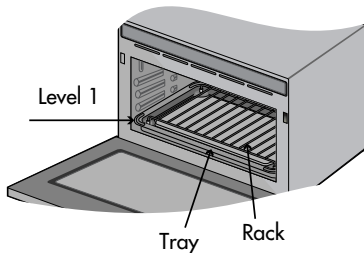

Press **STOP/CLEAR** (🛑).

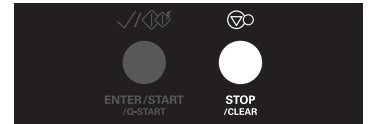

Turn the **FUNCTION** selection dial to select **Conv. Combi**.

The following indications are displayed: "≈", "☼".



Turn the **CONTROL** dial until display shows "200°C".

Press **ENTER/START/Q-START** (✓/☼) for temperature confirmation.



Turn the **CONTROL** dial until display shows "300W".

Press **ENTER/START/Q-START** (✓/☼) for power confirmation.



Turn the **CONTROL** dial until display shows "25:00".



Press **ENTER/START/Q-START** (✓/☼).

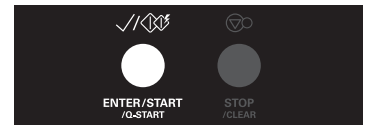

After cooking you must wear heat proof oven gloves to take metal tray out of the oven as the tray and its contents will be very hot.

For Steam+

Cooking

- ◆ When Steam cooking, Set the time to a minimum of 3 min.



- ◆ Before Steam cooking, clean out the water vessel and fill it with clean water to the MAX fill line.



- ◆ If Display shows "☹" and emits a chime, check the water level in the vessel and ensure that it is installed securely.

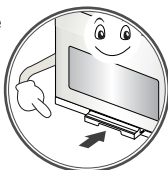

- ◆ After finishing steam cooking, please use the Steam Multi Clean Function to remove the residual water from the steam generator.
(Refer to page 56 for more information about the **Steam Multi Clean Function**)

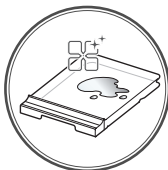

- ◆ When cooking with steam often, a scale build up of Calcium and magnesium will result on the cavity walls of the oven. Even though it is quite safe to the human body, it is best cleaned up regularly with a soft towel and a water and white **Vinegar** solution.



- ◆ Never fill the steam water vessel with **hot water**.

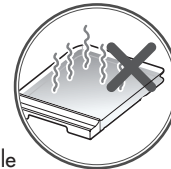

- ◆ It is strongly recommended that filtered (purified) water be used in the steam water vessel to reduce scale build up.

** Please read carefully, before using steam function.*

CAUTION WHEN USING WATER VESSEL.

- Do not use it with any fluid or mixture other than water.
- Use only potable water (purified).
- Do not fill it with hot water.
- Fill the water vessel up to the line indicated on the side.
- Do not tilt the water vessel filled with water.
- Make sure to empty the water out and clean the water vessel after cooking.
- Do not use the water vessel in any other way except for providing water for steam cooking.
- If you use it for over 30 minutes, re-fill the water vessel with water within 30 minutes from the start of cooking.

Micro Power Steam+ Cooking

In the following example I will show you how to use the Micro Power Steam+ Cooking mode to cook food on 450W power for 5 minutes.



Your oven has five microwave Power settings. High power is automatically selected. The power level can be changed if desired.

This feature allows you to cook food with microwave and steam at the same time. This generally means food keep its moisture by adding steam. This feature is suitable for food such as vegetables, rice and other non fatty foods. It is not necessary to cover food in this mode of cooking. Before cooking, fill the water vessel with purified water up to the MAX fill line.

POWER

HIGH	700 W
MEDIUM HIGH	450 W
MEDIUM	300 W
DEFROST MEDIUM LOW	180 W
LOW	90 W

* Refer to next page for Accessory instructions.

Make sure that you have correctly installed your oven as described earlier in this book.

Press **STOP/CLEAR** ().

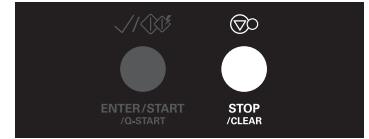

Turn the **FUNCTION** selection dial to select **Microwave**.

The following indication is displayed: "  "

Press **STEAM+/CLOCK** ().

The following indication is displayed: "  "



Turn the **CONTROL** dial until display shows "450W".

Press **ENTER/START/Q-START** () for power confirmation.



Turn the **CONTROL** dial until display shows "5:00".

Press **ENTER/START/Q-START** ().

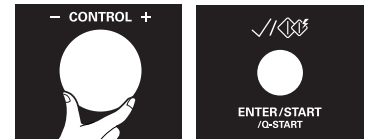

Cooking Guide

This table shows recommended settings and times for Micro Power Steam+ Cooking. The times are only a guide.

Allow for difference in individual tastes and preferences. The times may also vary due to the shape, cut, and composition of the food.

<i>Food</i>	<i>Amount</i>	<i>Utensil</i>	<i>Level</i>	<i>Cook mode</i>	<i>Cook time (minutes)</i>
Chicken Pieces	4 pieces	Rack on the oven bottom	Bottom	Steam+ 300W	12~16
Reheat Lasagna	2-4 servings	Heatproof glass dish on the Rack on the oven bottom	Bottom	Steam+ 300W	8~12
Reheat Plated Meal	1 serving	Heatproof glass dish on the Rack on the oven bottom	Bottom	Steam+ 300W	5~8
Rice / Risotto	1 cup	Heatproof glass dish on the Rack on the oven bottom	Bottom	Steam+ 300W	18~22
Frozen Vegetables	0.5 kg	Heatproof glass dish on the Rack on the oven bottom	Bottom	Steam+ 700W	10~13
Jacket Potatoes	4ea. med	Rack on the oven bottom	Bottom	Steam+ 700W	13~15
Pudding	0.3 kg	Heatproof glass dish on the Rack on the oven bottom	Bottom	Steam+ 180W	20~30

Rack

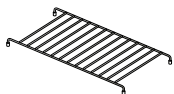

* Rack Location

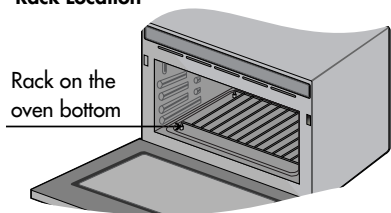

Convection Steam+ Cooking

In the following example I will show you how to use the Convection Steam+ Cooking mode to cook food for 50 minutes at 230°C temperature.

If you do not set a temperature your oven will automatically select 180°C, the cooking temperature can be changed by turning the **Control dial**.

This feature allows you to cook food with convection and steam at the same time. Use this feature to cook food that needs to retain moisture and have a crisp brown exterior. This feature is suitable for baking cake/bread and roasting meat/poultry. Before cooking, fill the water vessel with purified water up to the Max fill line.

The Metal tray must be used during Convection Steam+ cooking.

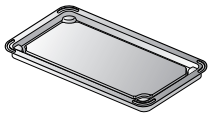

* Tray Location

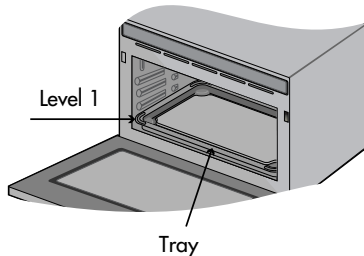

Press **STOP/CLEAR** (🛑).

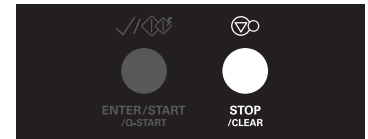

Turn the **FUNCTION selection dial** to select **Conv.**

The following indication is displayed: "🌀"

Press **STEAM+/CLOCK** (👉).

The following indication is displayed: "👉"



Turn the **CONTROL dial** until display shows "230°C".

Press **ENTER/START/Q-START** (✓/🌀) for temperature confirmation.

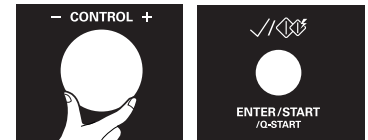

Turn the **CONTROL dial** until display shows "50:00".



Press **ENTER/START/Q-START** (✓/🌀).

When cooking you can increase or decrease cooking time by turning **CONTROL dial**.

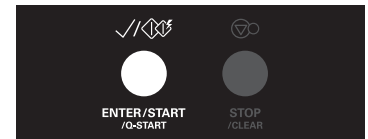

Cooking Guide

This table shows recommended settings and times for Convection Steam+ Cooking. The times are only a guide.

Allow for difference in individual tastes and preferences. The times may also vary due to the shape, cut, and composition of the food.

<i>Food</i>	<i>Utensil</i>	<i>Level</i>	<i>Cook mode</i>	<i>Cook time (minutes)</i>
Homemade Pizza	Metal tray	2	Steam+ Convection 180°C	15~20
Cookies	Metal tray	2	Steam+ Convection 170°C	15~20
Chocolate Cake	20 cm Cake pan on the Rack on the Metal tray	1	Steam+ Convection 170°C	30~40
Gratin Dauphinois	Gratin dish on the Rack on the Metal tray	1	Steam+ Convection 180°C	30~40
Lasagna	26 x 17 cm baking dish on the Rack on the Metal tray	2	Steam+ Convection 180°C	30~40
Roast Chicken 1.5 kg	Rack on the Metal tray	1	Steam+ Convection 200°C	60~80
Roast Pork 1 kg	Rack on the Metal tray	1	Steam+ Convection 180°C	100~140

In the following example I will show you how to use the Steam+ mode to cook food for 25 minutes.



This feature allows you to steam food such as vegetables, seafood, fish and eggs. Before cooking, fill the water vessel with purified water up to the Max fill line.

The Metal tray must be used during Steam+ cooking.

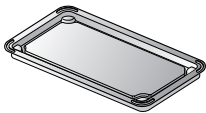

* Tray Location

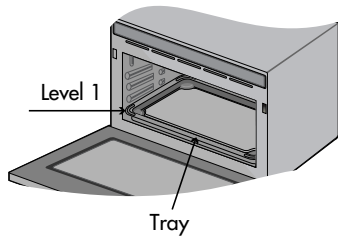

Press **STOP/CLEAR** (🚫).

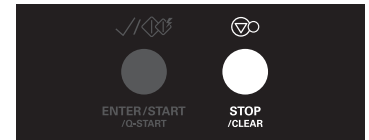

Press **STEAM+/CLOCK** (👏).

The following indication is displayed: "👏"

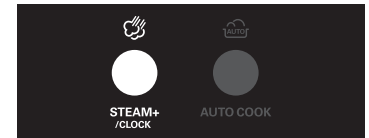

Turn the **CONTROL dial** until display shows "25:00".

Press **ENTER/START/Q-START** (✓/↔).

After cooking you must wear heat proof oven gloves to take metal tray out of the oven as the tray and its contents will be very hot.

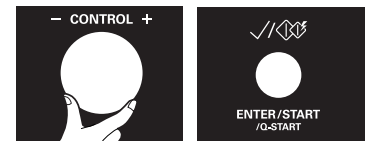
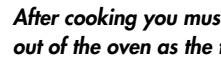

Cooking Guide

This table shows recommended times for Steam+. The times are only a guide. Allow for difference in individual tastes and preferences. The times may also vary due to the shape, cut, and composition of the food.

Food	Amount	Utensil	Level	Cook time (minutes)	Instructions
Mussels	1 kg	Metal tray	1	10~12	Clean the mussels, discarding any broken shell or dead mussels. Add 1 cup of dry white wine. After steaming, drain and reserve mussel liquor and reduce it to 3/4 cup. Remove top shell of mussels. Add butter and pepper to broth and pour over mussels.
Prawn	0.5 kg	Rack on the Metal tray	1	9~11	Clean the prawn with shell in salted water.
Whole Fish	0.5 kg	Rack on the Metal tray	1	25~30	Prepare fresh fish
Fish Fillet	0.5 kg	Metal tray	1	10~15	Season as desired.
Sausage	0.5 kg	Rack on the Metal tray	1	22~25	Slit the sausage skin.
Ham	0.5 kg	Metal tray	1	13~16	Slice ham.
Chicken Breast	4 pieces	Rack on the Metal tray	1	16~18	Season as desired.
Eggs	8ea.	Rack on the Metal tray	1	17~19	Place on the rack on the Metal tray
Broccoli, Florets	0.3 kg	Metal tray	1	12~14	Clean and cut into floret.
Spinach	0.3 kg	Metal tray	1	7~9	Clean
Eggplant	3-4ea.	Metal tray	1	12~14	Clean and cut in half length ways.
Tomato	0.5 kg	Metal tray	1	12~15	Clean and cut into small pieces.
Apple	3-4ea.	Metal tray	1	12~15	Peel and core. Cut into slices or cubes.
Potato	3-4ea.	Metal tray	1	40~50	Peel and cut into small pieces.

Auto Cooking

In the following example I will show you how to cook 0.4kg of chicken skewers



Auto Cooking menus are preprogrammed. Auto Cooking allows you to cook popular foods by selecting the food type and the weight of the food.

Press **STOP/CLEAR** ().



Press **AUTO COOK** ().

The following indication is displayed: "Auto "

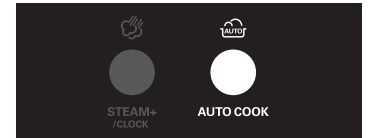

Turn the **CONTROL** dial until display shows "Ac 3".

Press **ENTER/START/Q-START** () for category confirmation.

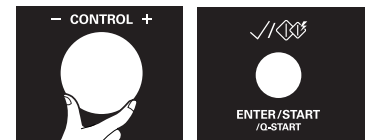

Turn the **CONTROL** dial until display shows "0.4kg".

Press **ENTER/START/Q-START** ().

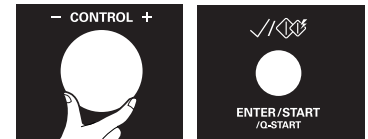

After cooking you must wear heat proof oven gloves to take metal tray out of the oven as the tray and its contents will be very hot.

Function	Category		Weight Limit	Utensil	Level	Food Temp.	Instructions	
Auto Cooking	Ac 1	Jacket Potatoes	0.2-1.0kg	Rack on the Metal tray	1	Room	Choose medium sized potatoes. (200-220g per each) Wash and dry potatoes. Pierce potatoes several times with a fork. Place food on the rack on the metal tray. Choose the menu and weight, press start. After cooking, remove food from the oven. Let stand covered with foil for 5 minutes.	
	Ac 2	Chicken Schnitzel	0.2-0.6kg	Metal tray	3	Refrigerated	<p>Ingredients Chicken breasts of 150-200g per each. 1 cup flour 2 eggs, lightly beaten 1 cup finely ground breadcrumbs Salt and pepper to taste</p> <ol style="list-style-type: none"> Season chicken breasts with salt and pepper or as desired, coat in flour and brush with beaten eggs. Coat with finely ground breadcrumbs and brush surface of schnitzel with oil. Place food on the metal tray. Choose the menu and weight, press start. When BEEP's are heard, turn food over and press start to continue cooking. 	
	Ac 3	Chicken Skewers	0.2-0.8kg	Rack on the Metal tray	3	Refrigerated	<table border="0"> <tr> <td>Ingredients Chicken wings Skewers (metal or wood)</td> <td>For Marinade : 1/2 cup soy sauce 1/2 cup honey 2 tablespoons lemon juice 2 garlic cloves, crushed</td> </tr> </table> <ol style="list-style-type: none"> Cut chicken wings into 2 pieces. Combine the ingredients of marinade and marinate chicken wings for 3-4 hours. Thread chicken onto skewers. Place food on the rack on the metal tray. Choose the menu and weight, press start. When BEEP's are heard, turn food over and press start to continue cooking. 	Ingredients Chicken wings Skewers (metal or wood)
Ingredients Chicken wings Skewers (metal or wood)	For Marinade : 1/2 cup soy sauce 1/2 cup honey 2 tablespoons lemon juice 2 garlic cloves, crushed							

Function	Category		Weight Limit	Utensil	Level	Food Temp.	Instructions
Auto Cooking	Ac 4	Fresh Pizza	0.3-0.6kg	Metal tray	3	Room	<p>For example of 0.4kg pizza</p> <div style="border: 1px solid black; padding: 5px;"> <p>Ingredients For Dough : 120g all-purpose or bread flour 1 teaspoon active dry yeast 1/3 teaspoon salt 1 teaspoon sugar 70ml warm water 1 teaspoon extra-virgin olive oil, Plus a little for coating</p> <p>For Toppings : 3 tablespoons tomato sauce 30g sausage, sliced 1/2 onion, sliced 2 fresh mushrooms, sliced 1/2 fresh pepper 100g grated mozzarella cheese</p> </div> <p>1. Combine the ingredients of dough in a large mixing bowl. 2. Knead with an electric mixer to make smooth and elastic dough. 3. Roll dough out and place dough on the greased metal tray. 4. Spread tomato sauce. Top with toppings and cheese. 5. Choose the menu and weight, press start.</p>
	Ac 5	Frozen Pizza	0.3-0.6kg	Rack on the Metal tray	1	Frozen	<p>Remove pizza from packaging and place food on the rack on the metal tray. Choose the menu and weight, press start.</p>
	Ac 6	Chicken Nuggets	0.2-0.4kg	Metal tray	3	Frozen	<p>Brush surface of chicken nuggets with oil. Place food on the metal tray. Choose the menu and weight, press start.</p>

Function	Category		Weight Limit	Utensil	Level	Food Temp.	Instructions
Auto Cooking	Ac 7	Pork Chops	0.2-0.8kg	Rack on the Metal tray	3	Refrigerated	Choose pork chops of 200g weight and 2.5cm thickness each. Season with salt and pepper or as desired. Place food on the rack on the metal tray. Choose the menu and weight, press start. When BEEP's are heard, turn food over and press start to continue cooking.
	Ac 8	Lamb Chops	0.3-0.6kg	Rack on the Metal tray	3	Refrigerated	Choose lamb chops of 100g weight and 1.5~2.0cm thickness each. Season with salt and pepper or as desired. Place food on the rack on the metal tray. Choose the menu and weight, press start. When BEEP's are heard, turn food over and press start to continue cooking.
	Ac 9	Beef Steak	0.3-0.6kg	Rack on the Metal tray	3	Refrigerated	Choose steak of 200g weight and 2.5cm thickness each. Season with salt and pepper or as desired. Place food on the rack on the metal tray. Choose the menu and weight, press start. When BEEP's are heard, turn food over and press start to continue cooking.
	Ac 10	Salmon Steak	0.2-0.8kg	Rack on the Metal tray	3	Refrigerated	Choose salmon fillet of 200g weight and 2.5cm thickness each. Brush surface of salmon with oil and season as desired. Place food on the rack on the metal tray. Choose the menu and weight, press start. When BEEP's are heard, turn food over and press start to continue cooking.

Function	Category		Weight Limit	Utensil	Level	Food Temp.	Instructions
Auto Cooking	Ac 11	Lasagna	1	26x17cm baking dish on the Rack on the Metal tray	2	Room	<p>Ingredients 9 lasagna sheets 500g spaghetti sauce 600g cheese sauce 300g grated mozzarella cheese 30g grated parmesan cheese</p> <p>For Cheese sauce : 60g butter 50g plain flour Pinch ground nutmeg 500ml milk 20g grated parmesan cheese</p> <p>Melt butter in a small saucepan. Add flour and nutmeg, stirring until smooth. Gradually add milk and stir until it boils and thickens. Reduce heat and add parmesan cheese. Stir until cheese melts well.</p> <ol style="list-style-type: none"> 1. Cook lasagna sheets according to package directions and drain. 2. Spread about 125g spaghetti sauce in a 26x17cm baking dish. 3. Layer 3 lasagna sheets, 300g cheese sauce, 125g spaghetti sauce, 100g mozzarella cheese. Repeat layering. 4. Finally layer remaining lasagna sheets, spread 125g spaghetti sauce, sprinkle with 100g mozzarella cheese and 30g parmesan cheese. 5. Place baking dish on the rack on the metal tray. Choose the menu and weight, press start.

<i>Function</i>	<i>Category</i>		<i>Weight Limit</i>	<i>Utensil</i>	<i>Level</i>	<i>Food Temp.</i>	<i>Instructions</i>
Auto Cooking	Ac 12	Roast Vegetables	0.2-0.4kg	Metal tray	3	Refrigerated	<p>Ingredients</p> <p>Eggplants, cut into 1-2cm thickness Zucchini, cut into 1-2cm thickness Onions, cut into wedges Sweet peppers, cut in half lengthwise and discard seeds Whole cherry tomatoes Mushrooms, cut in half</p> <p>Slice vegetables into large pieces. Brush vegetables with melted butter or oil and season as desired. Place food on the metal tray. Choose the menu and weight, press start. When BEEP's are heard, turn food over and press start to continue cooking.</p>
	Ac 13	Sausages	0.2-0.6kg	Rack on the Metal tray	3	Refrigerated	<p>Remove sausages from packaging and slit the sausage skin. Place food on the rack on the metal tray. Choose the menu and weight, press start. When BEEP's are heard, turn food over and press start to continue cooking.</p>

Function	Category		Weight Limit	Utensil	Level	Food Temp.	Instructions
Auto Cooking	Ac 14	Meat Pie	1	20cm pie tin on the Rack on the Metal tray	1	Room	<p>Ingredients 600-650g meat mixture 2 puff pastry sheets, thawed (180~200g/sheet) 1 egg, lightly beaten</p> <p>For Meat mixture : 1 onion, chopped 500g steak, finely chopped 2 tablespoons plain flour 250ml bouillon 1/2 teaspoon thyme Pinch ground nutmeg Salt and pepper to taste</p> <p>Saute chopped onion over a low heat in a saucepan until soften. Add chopped steak and stir until browned. Sprinkle flour over steak and continue cooking for further 2 minutes. Gradually add bouillon and stir constantly until it boils and thickens. Add all remaining ingredients. Cover and simmer for 30 minutes.</p> <ol style="list-style-type: none"> On a lightly floured surface, roll out 1 puff pastry sheet into a circle and line a 20cm pie tin. Trim edges, leaving a little overhang and prick with a fork. Fill with the cooled meat mixture and brush around edges with beaten egg to top will stick to it. Roll out the remaining pastry sheet and place on top of pie to form a lid and trim edges. Press edges together with a fork to seal. Cut a vent in top of pie to allow steam to escape. Brush top with remaining beaten egg. Place pie tin on the rack on the metal tray. Choose the menu and weight, press start.

Function	Category		Weight Limit	Utensil	Level	Food Temp.	Instructions										
Auto Cooking	Ac 15	Meat Loaf	1	23x13cm loaf pan on the Rack on the Metal tray	1	Refrigerated	<p>Ingredients</p> <table border="0"> <tr> <td>1 kg lean minced beef</td> <td>breadcrumbs</td> </tr> <tr> <td>2 eggs, lightly beaten</td> <td>1 tablespoon flour</td> </tr> <tr> <td>1 onion, chopped</td> <td>1 tablespoon curry powder</td> </tr> <tr> <td>300g tomato sauce</td> <td>1/4 cup water</td> </tr> <tr> <td>1/2 cup finely ground</td> <td>Salt and pepper to taste</td> </tr> </table> <p>In a large bowl, combine all ingredients. Shape into loaf and put into a greased 23x13cm loaf pan. Place loaf pan on the rack on the metal tray. Choose the menu and weight, press start.</p>	1 kg lean minced beef	breadcrumbs	2 eggs, lightly beaten	1 tablespoon flour	1 onion, chopped	1 tablespoon curry powder	300g tomato sauce	1/4 cup water	1/2 cup finely ground	Salt and pepper to taste
	1 kg lean minced beef	breadcrumbs															
2 eggs, lightly beaten	1 tablespoon flour																
1 onion, chopped	1 tablespoon curry powder																
300g tomato sauce	1/4 cup water																
1/2 cup finely ground	Salt and pepper to taste																
Ac 16	Potato Gratin	0.5-1.2kg	microwave-safe baking dish on the rack on the metal tray	1	Room	<p>For example of 1.0 kg potato gratin</p> <p>Ingredients</p> <p>Potato mixture 300ml heavy cream 350g grated Gruyere cheese</p> <p>For Potato mixture :</p> <p>1kg potatoes 400ml milk 1 1/2 teaspoons salt Pinch ground nutmeg</p> <p>Slice potatoes into 3mm thickness. Combine all ingredients in a saucepan and simmer over medium heat until milk boils and thickens. Keep Stirring potatoes and scraping bottom of pan regularly to prevent sticking.</p> <p>Place half of the potato mixture into a greased 25x25cm baking dish, pour half of heavy cream and sprinkle 100g Gruyere cheese. Add the rest of potato mixture, pour remaining cream and finally sprinkle top with remaining Gruyere cheese. Place baking dish on the low rack on the metal tray. Choose the menu and weight, press start.</p>											

Function	Category		Weight Limit	Utensil	Level	Food Temp.	Instructions																
Auto Cooking	Ac 17	Rice/ Pasta	0.1-0.3kg	microwave-safe bowl (deep glass pot) on the Rack on the Metal tray	1	Room	Place rice/pasta and boiling water with 1/4 to 1 teaspoon salt in a deep and large bowl(3L). Place bowl on the rack on the metal tray. Choose the menu and weight, press start. <table border="1"> <tr> <td>Weight</td> <td>100g</td> <td>200g</td> <td>300g</td> <td>Cover</td> </tr> <tr> <td rowspan="2">Water</td> <td>Rice</td> <td>250ml</td> <td>500ml</td> <td>750ml</td> <td>Cover and vent with wrap</td> </tr> <tr> <td>Pasta</td> <td>400ml</td> <td>800ml</td> <td>1200ml</td> <td>Uncover</td> </tr> </table> <p>** Rice - After cooking, stand covered for 5 minutes or until water is absorbed. ** Pasta - During the cooking, stir several times if required. After cooking, let stand 1-2 minutes. Rinse pasta with cold water.</p>	Weight	100g	200g	300g	Cover	Water	Rice	250ml	500ml	750ml	Cover and vent with wrap	Pasta	400ml	800ml	1200ml	Uncover
		Weight	100g	200g	300g	Cover																	
		Water	Rice	250ml	500ml	750ml	Cover and vent with wrap																
			Pasta	400ml	800ml	1200ml	Uncover																
Ac 18	French Fries	0.2-0.5kg	Metal tray	3	Frozen	Spread frozen potato products out on the greased metal tray. For the best results, cook in a single layer. Choose the menu and weight, press start.																	
Ac 19	Reheat Dinner Plate	1 serving (0.5-0.6kg)	microwave-safe plate on the Rack on the Metal tray	1	Refrigerated	Place leftover food (meat, chicken, mashed potato, vegetable etc.) on a plate. Cover with 2cm vented plastic wrap. Place plate on the rack on the metal tray. Choose the menu and weight, press start. After cooking, allow to stand for 3 minutes.																	
Ac 20	Reheat Soup	0.2-0.8kg	microwave-safe plate on the Rack on the Metal tray	1	Refrigerated	Pour soup into a microwave-safe bowl. Cover with 2cm vented plastic wrap. Place bowl on the rack on the metal tray. Choose the menu, press start. After cooking, stir for 3-4 seconds and stand covered for 3 minutes.																	

< Metal Tray >

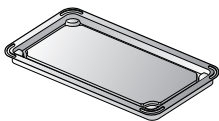

< Rack >

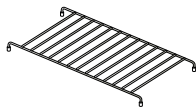

< Rack + Metal Tray >

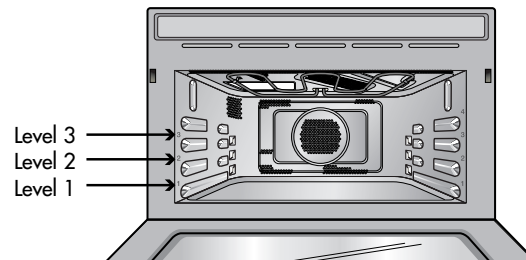
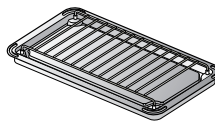

Steam+

Auto Cooking

In the following example I will show you how to cook 0.5kg of potatoes.



Steam+ Auto Cooking menus are programmed. Steam+ Auto Cooking allows you to cook popular foods by selecting the food type and the weight of the food.

CAUTION

After finishing steam cooking, please use the Steam Multi Clean function to remove the residual water from the steam generator. (Refer to page 56 for more information about the **Steam Multi Clean Function**)

Press **STOP/CLEAR** ().

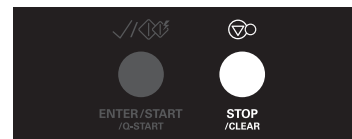

Press **AUTO COOK** ().

The following indication is displayed: "  "

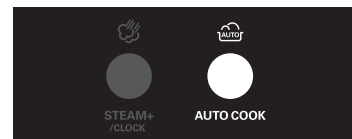

Press **STEAM+/CLOCK** ().

The following indication is displayed: "  "

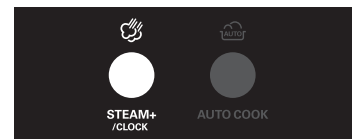

Turn the **CONTROL dial** until display shows "St 3".

Press **ENTER/START/Q-START** () for category confirmation.

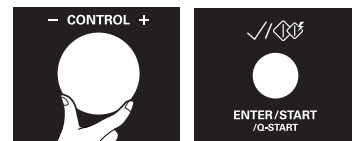

Turn the **CONTROL dial** until display shows "0.5kg".

Press **ENTER/START/Q-START** ().

After cooking you must wear heat proof oven gloves to take metal tray out of the oven as the tray and its contents will be very hot.

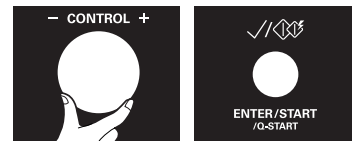

Function	Category		Weight Limit	Utensil	Level	Food Temp.	Instructions
Steam+ Auto Cooking	St 1	Broccoli	0.2-0.4kg	microwave-safe dish on the Rack on the Metal tray	1	Room	Fill water vessel with purified water up to the Max fill line. Cut broccoli into small florets. (12-15g/piece) Place food in a microwave-safe dish on the rack on the metal tray. Choose the menu and weight, press start.
	St 2	Carrot	0.2-0.6kg	microwave-safe bowl on the Rack on the Metal tray	1	Room	Fill water vessel with purified water up to the Max fill line. Slice carrot into 5mm thickness Place food in a microwave-safe bowl on the rack on the metal tray. Choose the menu and weight, press start.
	St 3	Potatoes	0.2-1.0kg	microwave-safe dish on the Rack on the Metal tray	1	Frozen	Fill water vessel with purified water up to the Max fill line. Choose medium sized potatoes. (200-220g each) Wash and dry potatoes. Pierce potatoes several times with a fork. Place food in a microwave-safe dish on the rack on the metal tray. Choose the menu and weight, press start.
	St 4	Green Beans	0.1-0.3kg	microwave-safe dish on the Rack on the Metal tray	1	Room	Fill water vessel with purified water up to the Max fill line. Place food in a microwave-safe dish on the rack on the metal tray. Choose the menu and weight, press start.
	St 5	Frozen Vegetables	0.2-0.6kg	microwave-safe bowl on the Rack on the Metal tray	1	Frozen	Fill water vessel with purified water up to the Max fill line. Place food in a microwave-safe bowl on the Rack on the Metal tray. Choose the menu and weight, press start.
	St 6	Eggs	5-10 eggs	Rack on the Metal Tray	1	Refrigerated	Fill water vessel with purified water up to the Max fill line. Place food on the rack on the metal tray. Choose the menu and weight, press start.
	St 7	Chicken Breasts	0.2-0.6kg	microwave-safe dish on the Rack on the Metal tray	1	Refrigerated	Fill water vessel with purified water up to the Max fill line. Place food in a microwave-safe dish on the rack on the metal tray. Choose the menu and weight, press start.

<i>Function</i>	<i>Category</i>		<i>Weight Limit</i>	<i>Utensil</i>	<i>Level</i>	<i>Food Temp.</i>	<i>Instructions</i>
Steam+ Auto Cooking	St 8	Mussels	0.5-1.0kg	Metal tray	1	Refrigerated	<div style="border: 1px solid black; padding: 5px;"> <p>Ingredients Mussels 300ml dry white wine 1 teaspoon chopped parsley 2 garlic cloves, crushed</p> </div> <p>Fill water vessel with purified water up to the Max fill line. Clean mussels and discard any broken shell or dead mussels. Place mussels on the metal tray in a single layer and add remaining ingredients. Choose the menu and weight, press start.</p>
	St 9	Prawns	0.2-0.5kg	microwave-safe dish on the Rack on the Metal tray	1	Refrigerated	Fill water vessel with purified water up to the Max fill line. Place food in a microwave-safe dish on the rack on the metal tray. Choose the menu and weight, press start.
	St 10	Fish Fillet	0.2-0.6kg	microwave-safe dish on the Rack on the Metal tray	1	Refrigerated	Fill water vessel with purified water up to the Max fill line. Place food in a microwave-safe dish on the rack on the metal tray. Choose the menu and weight, press start.
	St 11	Roast Whole Chicken	0.8-1.5kg	Rack on the Metal tray	1	Refrigerated	Fill water vessel with purified water up to the Max fill line. Brush chicken with melted butter or oil and season as desired. Place food breast-side down on the rack on the metal tray. When BEEP's are heard, turn food over and press start to continue cooking. After cooking, stand covered with foil for 10 minutes.
	St 12	Roast Whole Fish	0.3-0.6kg	Rack on the Metal tray	3	Refrigerated	Fill water vessel with purified water up to the Max fill line. Brush fish with melted butter or oil and season as desired. Place food on the rack on the metal tray. Choose the menu and weight, press start. When BEEP's are heard, turn food over and press start to continue cooking.

Function	Category		Weight Limit	Utensil	Level	Food Temp.	Instructions
Steam+ Auto Cooking	St 13	Roast Beef	0.5-1.5kg	Rack on the Metal tray	1	Refrigerated	Fill water vessel with purified water up to the Max fill line. Brush beef with melted butter or oil and season as desired. Place food on the rack on the metal tray. Choose the menu and weight, press start. When BEEP's are heard, turn food over and press start to continue cooking. After cooking, stand covered with foil for 10 minutes.
	St 14	Roast Leg of Lamb	0.5-1.5kg	Rack on the Metal tray	1	Refrigerated	Fill water vessel with purified water up to the Max fill line. Brush leg of lamb with melted butter or oil and season as desired. Place food on the rack on the metal tray. Choose the menu and weight, press start. When BEEP's are heard, turn food over and press start to continue cooking. After cooking, stand covered with foil for 10 minutes.
	St 15	Chicken Pieces	0.2-0.8kg	Rack on the Metal tray	3	Refrigerated	Brush chicken pieces with melted butter or oil and season as desired. Place food on the rack on the metal tray. Choose the menu and weight, press start. When BEEP's are heard, turn food over and press start to continue cooking.
	St 16	Grilled Prawns	0.2-0.4kg	Rack on the Metal tray	3	Refrigerated	Brush prawns with melted butter or oil and season as desired. Place food on the rack on the metal tray. Choose the menu and weight, press start. When BEEP's are heard, turn food over and press start to continue cooking.

Function	Category		Weight Limit	Utensil	Level	Food Temp.	Instructions																										
Steam+ Auto Cooking	St 17	Risotto	0.1-0.3kg	microwavesafe bowl (deep glass pot) on the Rack on the Metal tray	1	Room	<table border="1"> <tr> <td>Rice, short-grain</td> <td>100g</td> <td>200g</td> <td>300g</td> </tr> <tr> <td>Onion, chopped</td> <td>1 ea</td> <td>1 1/2 ea</td> <td>2 ea</td> </tr> <tr> <td>Oil ,liquid</td> <td>2 tablespoons</td> <td>3 tablespoons</td> <td>4 tablespoons</td> </tr> <tr> <td>Boiling chicken broth</td> <td>500 ml</td> <td>750 ml</td> <td>1000 ml</td> </tr> <tr> <td>Salt</td> <td colspan="3">To taste</td> </tr> </table> <p>Fill water vessel with purified water up to the Max fill line. Add rice, chopped onion and liquid oil in a deep and large bowl (3L) and mix to coat with oil. Place bowl on the rack on the oven bottom and cook them on 700W power for 4-5 minutes. (Refer to the micro power cooking for details on page 24.) Add boiling chicken broth and salt into rice, stirring. Do not cover to vaporize whole water. Place bowl on the rack on the metal tray. Choose the menu and weight, press start. Stir at least twice during cooking. After cooking, stand covered for 5 minutes or until water is absorbed.</p>				Rice, short-grain	100g	200g	300g	Onion, chopped	1 ea	1 1/2 ea	2 ea	Oil ,liquid	2 tablespoons	3 tablespoons	4 tablespoons	Boiling chicken broth	500 ml	750 ml	1000 ml	Salt	To taste					
	Rice, short-grain	100g	200g	300g																													
Onion, chopped	1 ea	1 1/2 ea	2 ea																														
Oil ,liquid	2 tablespoons	3 tablespoons	4 tablespoons																														
Boiling chicken broth	500 ml	750 ml	1000 ml																														
Salt	To taste																																
St 18	Pudding	1	microwavesafe bowl (deep glass pot) on the Rack on the Metal tray	1	Room	<table border="1"> <tr> <td colspan="4">Ingredients</td> </tr> <tr> <td colspan="4">100g rice, short-grain</td> </tr> <tr> <td colspan="4">800ml milk</td> </tr> <tr> <td colspan="4">60g caster sugar</td> </tr> <tr> <td colspan="4">1 teaspoon vanilla extract</td> </tr> <tr> <td colspan="4">Lightly sweetened whipped cream</td> </tr> </table> <p>Fill water vessel with purified water up to the Max fill line. Combine rice, milk, sugar and vanilla extract in a deep and large bowl. Do not cover to vaporize whole water. Place bowl on the Rack on the Metal tray. Choose the menu and weight, press start. Stir at least twice during cooking. Serve warm or cold. If desired, garnish with lightly sweetened whipped cream.</p>				Ingredients				100g rice, short-grain				800ml milk				60g caster sugar				1 teaspoon vanilla extract				Lightly sweetened whipped cream			
Ingredients																																	
100g rice, short-grain																																	
800ml milk																																	
60g caster sugar																																	
1 teaspoon vanilla extract																																	
Lightly sweetened whipped cream																																	

Function	Category		Weight Limit	Utensil	Level	Food Temp.	Instructions
Steam+ Auto Cooking	St 19	Butter Cake	1	20cm cake pan on the rack on the Metal tray	1	Room	<p>Ingredients for marinade 250g plain flour, sifted 220g caster sugar 120g butter, softened 120ml milk 2 eggs, lightly beaten 2 teaspoons baking powder 1 teaspoon vanilla extract</p> <p>Fill water vessel with purified water up to the Max fill line. Add all ingredients in a large mixing bowl, stirring until smooth. Pour batter into a greased 20cm cake pan. Place cake pan on the rack on the metal tray. Choose the menu and weight, press start.</p>
	St 20	Fudge Brownies	1	20x20cm baking dish on the Rack on the Metal tray	1	Room	<p>Ingredients for marinade 120g butter, melted 110g caster sugar 2 eggs, lightly beaten 1 teaspoon salt 1 teaspoon baking powder 1 teaspoon vanilla extract 60g cocoa 125g plain flour, sifted 1 cup chocolate chips</p> <p>Fill water vessel with purified water up to the Max fill line. In a large mixing bowl, add sugar into melted butter and stir to combine. Add egg, salt, baking powder, vanilla extract and cocoa stirring until smooth. Add the flour and chips, again stirring until smooth. Pour batter into a greased 20x20cm baking dish. Place baking dish on the rack on the metal tray. Choose the menu and weight, press start.</p>

Defrost

*** When defrosting, use the rack only.**



Your oven has four microwave defrost settings:- **Meat, Poultry, Fish** and **Bread**; each defrost category has different power settings. Repeated presses of the **Defrost** button will select a different setting.

* Rack Location

Place rack on the oven base.

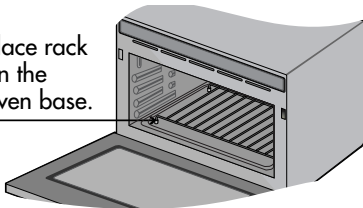

The temperature and density of food varies, I would recommend that the food be checked before cooking commences. Pay particular attention to large joints of meat and chicken, some foods should not be completely thawed before cooking. For example fish cooks so quickly that it is sometimes better to begin cooking while still slightly frozen. The bread programme is suitable for defrosting small items such as rolls or a small loaf. These will require a standing time to allow the centre to thaw. In the following example I will show you how to defrost 0.8Kg of frozen poultry.

Press **STOP/CLEAR** ().

Weigh the food that you are about to defrost. Be certain to remove any metallic ties or wraps; then place the food on microwave safe dish on the rack on the oven bottom and close the oven door.

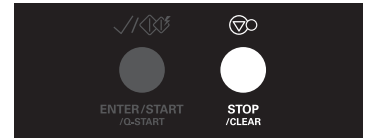

Turn the **FUNCTION** selection dial to select **Defrost**.

The following indication is displayed: " ** "



Turn the **CONTROL** dial until display shows "dEF2".

Press **ENTER/START/Q-START** () for category confirmation.

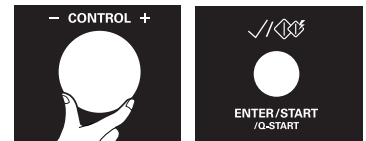

Enter the weight of the frozen food that you are about to defrost.

Turn the **CONTROL** dial until display shows "0.8kg" for the weight of frozen food.



Press **ENTER/START/Q-START** ().

During defrosting your oven will "BEEP", at which point open the oven door, turn food over, rotate dish a half turn and separate to ensure even thawing. Remove any portions that have thawed or shield them to help slow down thawing. After checking, close the oven door and press **ENTER/START/Q-START** () to resume defrosting. **Your oven will not stop defrosting (even when the beep is sounded) unless the door is opened.**

Defrosting Guide

- * Food to be defrosted should be in a suitable microwave proof container and place uncovered on the rack.
 - * If necessary, shield small areas of meat or poultry with flat pieces of aluminum foil. This will prevent thin areas becoming warm during defrosting. Ensure the foil does not touch the oven walls.
 - * Separate items like minced meat, chops, sausages and bacon as soon as possible.
- When BEEP is heard, turn food over and rotate dish a half turn.** Remove defrosted portions. Continue to defrost remaining pieces.
After defrosting, allow to stand until completely thawed.

Category	Weight Limit	Utensil	Level	Food
Meat (dEF1)	0.1 ~ 2.0 kg	Microwave-safe dish on the rack	Bottom	Meat Minced beef, Fillet steak, Cubes for stew, Sirloin steak, Pot roast, Rump roast, Beef burger Pork chops, Lamb chops, Rolled roast, Sausage, Cutlets(2cm) Turn food over, rotate dish a half turn and remove defrosted portions at beep. After defrosting, let stand for 5-15 minutes.
Poultry (dEF2)	0.1 ~ 2.0 kg			Poultry Whole chicken, Legs, Breasts, Turkey breasts. Turn food over, rotate dish a half turn and remove defrosted portions at beep. After defrosting, let stand for 30-40 minutes.
Fish (dEF3)	0.1 ~ 2.0 kg			Fish Fillets, Steaks, Whole fish, Sea foods Turn food over, rotate dish a half turn and remove defrosted portions at beep. After defrosting, let stand for 10-20 minutes.
Bread (dEF4)	0.1 ~ 0.5 kg	Paper towel on the rack		Bread Sliced bread, Buns, Baguette, etc. After defrosting, let stand for 5 minutes.

Defrost Steam+

*** When defrosting, use the rack only.**



Your oven has four microwave defrost settings:- **Meat, Poultry, Fish and Bread**; each defrost category has different power settings.

Repeated presses of the **Defrost** button will select a different setting.

After using steam defrost, Make sure to operate **multi clean (Drain Water)** function.

* Rack Location

Place rack on the oven base.

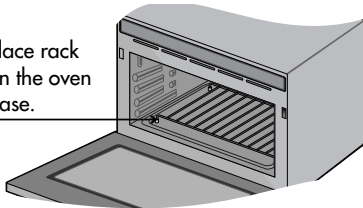

The temperature and density of food varies, I would recommend that the food be checked before cooking commences. Pay particular attention to large joints of meat and chicken, some foods should not be completely thawed before cooking. For example fish cooks so quickly that it is sometimes better to begin cooking while still slightly frozen. The bread programme is suitable for defrosting small items such as rolls or a small loaf. These will require a standing time to allow the centre to thaw. In the following example I will show you how to defrost 0.8Kg of frozen poultry.

Press **STOP/CLEAR** ().

Weigh the food that you are about to defrost. Be certain to remove any metallic ties or wraps; then place the food on microwave safe dish on the rack on the oven bottom and close the oven door.



Turn the **FUNCTION** selection dial to select **Defrost**.

The following indication is displayed: " ** "

Press **STEAM+/CLOCK** ().

The following indication is displayed: "  "



Turn the **CONTROL** dial until display shows "dEF2".

Press **ENTER/START/Q-START** () for category confirmation.

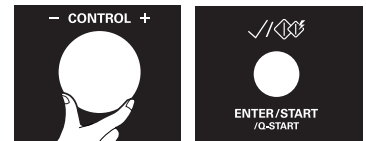

Enter the weight of the frozen food that you are about to defrost.

Turn the **CONTROL** dial until display shows "0.8kg" for the weight of frozen food.

Press **ENTER/START/Q-START** ().

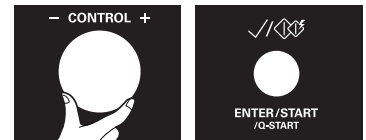

During defrosting your oven will "BEEP", at which point open the oven door, turn food over, rotate dish a half turn and separate to ensure even thawing. Remove any portions that have thawed or shield them to help slow down thawing. After checking, close the oven door and press **ENTER/START/Q-START** () to resume defrosting. **Your oven will not stop defrosting (even when the beep is sounded) unless the door is opened.**

Defrost Steam+ Guide

- * Food to be defrosted should be in a suitable microwave proof container and place uncovered on the rack.
- * If necessary, shield small areas of meat or poultry with flat pieces of aluminum foil. This will prevent thin areas becoming warm during defrosting. Ensure the foil does not touch the oven walls.
- * Separate items like minced meat, chops, sausages and bacon as soon as possible.
When BEEP is heard, turn food over and rotate dish a half turn. Remove defrosted portions. Continue to defrost remaining pieces.
 After defrosting, allow to stand until completely thawed.
- * Before Steam defrost, Clean out the water vessel and fill it with water to the MAX. fill line.
- * After Steam defrost, Use the steam multi-clean No."2" (Removal of residual water.)

Category	Weight Limit	Utensil	Level	Food
Meat (DEF1)	0.1 ~ 2.0 kg	Microwave-safe dish on the rack	Bottom	Meat Minced beef, Fillet steak, Cubes for stew, Sirloin steak, Pot roast, Rump roast, Beef burger Pork chops, Lamb chops, Rolled roast, Sausage, Cutlets(2cm) Turn food over, rotate dish a half turn and remove defrosted portions at beep. After defrosting, let stand for 5-15 minutes.
Poultry (DEF2)	0.1 ~ 2.0 kg			Poultry Whole chicken, Legs, Breasts, Turkey breasts. Turn food over, rotate dish a half turn and remove defrosted portions at beep. After defrosting, let stand for 30-40 minutes.
Fish (DEF3)	0.1 ~ 2.0 kg			Fish Fillets, Steaks, Whole fish, Sea foods Turn food over, rotate dish a half turn and remove defrosted portions at beep. After defrosting, let stand for 10-20 minutes.
Bread (DEF4)	0.1 ~ 0.5 kg	Paper towel on the rack		Bread Sliced bread, Buns, Baguette, etc. After defrosting, let stand for 5 minutes.

Steam multi clean

In the following example I will show you how to use multi-clean function.



To help clean a soiled cavity, remove scale build up within the steam generator or removal of residual water within the steam generator.

Press **STOP/CLEAR** ().

Press **STEAM+/CLOCK** ().



Turn **FUNCTION selection dial** to select **Multi clean**.

The following indication is displayed: "  ".



Turn **CONTROL dial** until display shows "1".



Press **ENTER/START/Q-START** ().



※ Multi clean

"1" (Steam Clean) : To assist cleaning an oil and grime soiled cavity.

"2" (Drain Water) : For the removal of residual water in the Steam generator.

"3" (Cleaning the Steam generator) : For removing sediment within the steam generator.

Quick Start

In the following example I will show you how to set 2 minutes of cooking on high power (700W).



The **Quick Start** feature allows you to set 30 seconds intervals of HIGH power (700W) cooking by pressing the **ENTER/START/Q-START** (✓/⏻) button.

Press **STOP/CLEAR** (⏻).

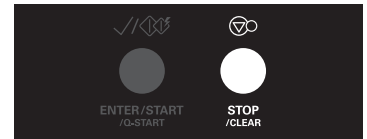

Press **ENTER/START/Q-START** (✓/⏻) four times to select 2 minutes on HIGH power (700W).
Your oven will start before you have finished the fourth press.

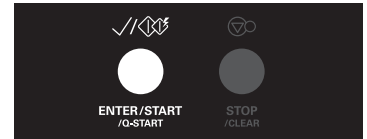

More or Less Cooking

In the following example I will show you how to change the preset **AUTO COOK** programmes for a longer or shorter cooking time.



If you find that your food is over or undercooked when using the Auto Cook programme, you can increase or decrease the cooking time by turning the **Control dial**.

You can lengthen or shorten the cooking time(except defrost mode) at any point by turning the **Control dial**.

Press **STOP/CLEAR** ().



Set the required **AUTO COOK** programme.

*See **AUTO COOK** (page. 37).

Select weight of food.

Press **ENTER/START/Q-START** ().



Turn the **CONTROL** dial.

The cooking time will increase or decrease.



To Clean Your Oven

1. Keep the inside of the oven clean

Food spatters or spilled liquids stick to oven walls and between seal and door surface. It is best to wipe up spillovers with a damp cloth immediately after cooking. This includes any spillage under the tray. Crumbs and spillovers will absorb microwave energy and lengthen cooking times. Use a damp cloth to wipe out crumbs that fall between the door and the frame. It is important to keep this area clean to assure a tight seal. Remove greasy spatters with a soapy cloth then rinse and dry. Do not use harsh detergent or abrasive cleaners. The Metal tray can be washed by hand or in the dishwasher.

2. Keep the outside of the oven clean

Clean the outside of your oven with soap and water then with clean water and dry with a soft cloth or paper towel. To prevent damage to the operating parts inside the oven, the water should not be allowed to seep into the ventilation openings. To clean control panel, open the door to prevent oven from accidentally starting, and wipe a damp cloth followed immediately by a dry cloth. Press STOP/CLEAR after cleaning.

3. If steam accumulates inside or around the outside of the oven door, wipe the panels with a soft cloth. This may occur when the oven is operated under high humidity conditions and in no way indicates a malfunction of the unit.
4. The door and door seals should be kept clean. Use only warm, soapy water, rinse then dry thoroughly.
DO NOT USE ABRASIVE MATERIALS, SUCH AS CLEANING POWDERS OR STEEL AND PLASTIC PADS.
Metal parts will be easier to maintain if wiped frequently with a damp cloth.
5. Unplug your oven from the electrical socket when you clean the control panel and glass with a soft damp cloth to prevent the unit from accidentally turning on if the Quick Start button is accidently pressed during cleaning.

To Clean the Cavity

Cavity front side

After cooking greasy food like baked chicken, wipe the front side of the cavity with a soft sponge and neutral detergent in the same direction of the textured surface, and finish off with a soft dry towel. (Inside of the door, remove any grease with a sponge or a soft towel.)



Cavity inside

- Regularly wipe the inside with a damp towel or sponge with a neutral detergent, and finish off with a soft dry towel.
- If you do not clean the inside of the cavity for a long time, oil stains may become difficult to remove and cause unpleasant odours.
- If it is hard to remove water marks around the steam outlet on the wall of the cavity, you can remove it more effectively with a sponge and white vinegar solution.
- After cooking with steam, wipe the inside of the cavity with a dry towel.
- It is recommended that the steam cleaning function be used after cooking greasy foods such as baked or roast chicken and fish.



Microwave-safe Utensils

Never use metal or metal trimmed utensils during microwave function

Microwaves cannot penetrate metal. They will bounce off any metal object in the oven and cause arcing, an alarming phenomenon that resembles lightning. Most heat resistant non metallic cooking utensils are safe for use in your oven. However, some may contain materials that render them unsuitable as microwave cookware. If you have any doubts about a particular utensil, there's a simple way to find out if it can be used in using microwave function. Place the utensil in question next to a glass bowl filled with water in using microwave function. Microwave at power HIGH for 1 minute. If the water heats up but the utensil remains cool to the touch, the utensil is microwave-safe. However, if the water does not change temperature but the utensil becomes warm, microwaves are being absorbed by the utensil and it is not safe for use in using microwave function. You probably have many items on hand in your kitchen right now that can be used as cooking equipment in using microwave function. Just read through the following checklist.

Dinner plates

Many kinds of dinner-ware are microwave-safe. If in doubt consult the manufacturer's literature or perform the microwave test.

Glassware

Glassware that is heat-resistant is microwave-safe. This would include all brands of oven tempered glass cookware. However, do not use delicate glassware, such as tumblers or wine glasses, as these might shatter as the food warms.

Plastic storage containers

These can be used to hold foods that are to be quickly reheated. However, they should not be used to hold foods that will need considerable time in the oven as hot foods will eventually warp or melt plastic containers.

Paper

Paper plates and containers are convenient and safe to use when using

microwave function, provided that the cooking time is short and foods to be cooked are low in fat and moisture. Paper towels are also very useful for wrapping foods and for lining baking trays in which greasy foods such as bacon are cooked. In general, avoid coloured paper products as the colour may run. Some recycled paper products may contain impurities which could cause arcing or fires when used in using microwave function.

Plastic cooking bags

Provided they are made specially for cooking, cooking bags are microwave safe. However, be sure to make a slit in the bag so that steam can escape. Never use ordinary plastic bags for cooking in using microwave function, as they will melt and rupture.

Plastic microwave cookware

A variety of shapes and sizes of microwave cookware are available. For the most part, you can probably use items you already have on hand rather than investing in new kitchen equipment.

Pottery, stoneware and ceramic

Containers made of these materials are usually fine for use in using microwave function, but they should be tested to be sure.

CAUTION

Some items with high lead or iron content are not suitable for cooking utensils.

Utensils should be checked to ensure that they are suitable for use when using microwave function.

Note:

Excessive cooking times and temperatures can cause a build up of condensation behind the door glass. The settings should readjusted to reduce either the cooking time or power. The condensation will disappear shortly after the cooking has stopped.

Food characteristics & Microwave cooking

Keeping an eye on things

The recipes in the book have been formulated with great care, but your success in preparing them depends on how much attention you pay to the food as it cooks. Always watch your food while it cooks. Your microwave function is equipped with a light that turns on automatically when the oven is in operation so that you can see inside and check the progress of your food. Directions given in recipes to elevate, stir, and the like should be thought of as the minimum steps recommended. If the food seems to be cooking unevenly, simply make the necessary adjustments you think appropriate to correct the problem.

Factors affecting microwave cooking times

Many factors affect cooking times. The temperature of ingredients used in a recipe makes a big difference in cooking times. For example, a cake made with ice-cold butter, milk, and eggs will take considerably longer to bake than one made with ingredients that are at room temperature. All of the recipes in this book give a range of cooking times. In general, you will find that the food remains under-cooked at the lower end of the time range, and you may sometimes want to cook your food beyond the maximum time given, according to personal preference. The governing philosophy of this book is that it is best for a recipe to be conservative in giving cooking times. While overcooked food is ruined for good. Some of the recipes, particularly those for bread, cake, and custards, recommend that food be removed from the oven when they are slightly undercooked. This is not a mistake. When allowed to stand, usually covered, these foods will continue to cook outside of the oven as the heat trapped within the outer portions of the food gradually travels inward. If the food is left in the oven until it is cooked all the way through, the outer portions will become overcooked or even burnt. You will become increasingly skilful in estimating both cooking and standing times for various foods.

Density of food

Light, porous food such as cakes and breads cook more quickly than heavy, dense foods such as roasts and casseroles. You must take care when microwaving porous food that the outer edges do not become dry and brittle.

Height of food

The upper portion of tall food, particularly roasts, will cook more quickly than the lower portion. Therefore, it is wise to turn tall food during cooking, sometimes several times.

Moisture content of food

Since the heat generated from microwaves tends to evaporate moisture, relatively dry food such as roasts and some vegetables should either be sprinkled with water prior to cooking or covered with non metallic material to retain moisture.

Bone and fat content of food

Bones conduct heat and fat cooks more quickly than meat. Care must be taken when cooking bony or fatty cuts of meat that they do not cook unevenly and do not become overcooked.

Quantity of food

The number of microwaves in your oven remains constant regardless of how much food is being cooked. Therefore, the more food you place in the oven, the longer the cooking time. Remember to decrease cooking times by at least one third when halving a recipe.

Shape of food

Microwaves penetrate only about 2.cm into food, the interior portion of thick foods are cooked as the heat generated on the outside travels inward. Only the outer edge of food is cooked by microwave energy; the rest is cooked by conduction. The worst possible shape for a food that is to be microwaved is a thick square. The corners will burn long before the centre is even warm . Round thin foods and ring shaped foods cook successfully in the microwave.

Food characteristics & Microwave cooking

Covering

A cover traps heat and steam which causes food to cook more quickly. Use a suitable lid or microwave cling film with a corner folded back to prevent splitting.

Browning

Meats and poultry that are cooked fifteen minutes or longer will brown lightly in their own fat. Food that are cooked for a shorter period of time may be brushed with a browning sauce such as worcestershire sauce, soy sauce or barbecue sauce to achieve an appetizing colour. Since relatively small amounts of browning sauces are added to food the original flavour of the recipe is not altered.

Covering with greaseproof paper

Greaseproofing effectively prevents spattering and helps food retain some heat. But because it makes a looser cover than a lid or clingfilm, it allows the food to dry out slightly.

Arranging and spacing

Individual foods such as baked potatoes, small cakes and hors d'oeuvres will heat more evenly if placed in the oven an equal distance apart, preferably in a circular pattern. Never stack foods on top of one another.

Stirring

Stirring is one of the most important of all microwaving techniques. In conventional cooking, food is stirred for the purpose of blending. Microwaved food, however, is stirred in order to spread and redistribute heat. Always stir from the outside towards the centre as the outside of the food heats first.

Turning over

Large, tall foods such as roasts and whole chickens should be turned so that the top and bottom will cook evenly. It is also a good idea to turn over cut up chicken and chops.

Placing thicker portions facing outwards

Since microwaves are attracted to the outside portion of food, it makes sense to place thicker portions of meat, poultry and fish to the outer edge of the baking dish. This way, thicker portions will receive the most microwave energy and the food will cook evenly.

Shielding

Strips of aluminium foil (which block microwaves) can be placed over the corners or edges of square and rectangular foods to prevent those portions from overcooking. Never use too much foil and make sure the foil is secured to the dish or it may cause 'arcing' in the oven and subsequent damage.

Elevating

Thick or dense foods can be elevated so that microwaves can be absorbed by the underside and centre of the foods.

Piercing

Foods enclosed in a shell, skin or membrane are likely to burst in the oven unless they are pierced prior to cooking. Such foods include jacket potatoes, yolks and whites of eggs, clams and oysters and whole vegetables and fruits.

Testing if cooked

Food cooks so quickly in a oven, it is necessary to test it frequently. Some foods are left in the microwave until completely cooked, but most foods, including meats and poultry, are removed from the oven while still slightly undercooked and allowed to finish cooking during standing time. The internal temperature of foods will rise between 3°C and 8°C during standing time.

Standing time

Foods are often allowed to stand for 3 to 10 minutes after being removed from the oven. Usually the foods are covered during standing time to retain heat unless they are supposed to be dry in texture (some cakes and biscuits, for example). Standing allows foods to finish cooking and also helps flavour blend and develop.

Questions & Answers

Q What's wrong when the oven light will not glow?

- A There may be several reasons why the oven light will not glow.
Light bulb has blown
Relay has failed

Q Does microwave energy pass through the viewing screen in the door?

- A No. The holes, or ports, are made to allow light to pass; they do not let microwave energy through.

Q Why does the beep tone sound when a button on the Control Panel is touched?

- A The beep tone sounds to assure that the setting is being properly entered.

Q Will the microwave function be damaged if it operates empty?

- A Yes Never run it empty.

Q Why do eggs sometimes pop?

- A When baking, frying, or poaching eggs, the yolk may pop due to steam build up inside the yolk membrane. To prevent this, simply pierce the yolk before cooking. Never microwave eggs in the shell.

Q Why is standing time recommended after microwave cooking is over?

- A After microwave cooking is finished, food keeps on cooking during standing time. This standing time finishes cooking evenly throughout the food. The amount of standing time depends on the density of the food.

Q Why doesn't my oven always cook as fast as the cooking guide says?

- A Check your cooking guide again to make sure you've followed directions correctly, and to see what might cause variations in cooking time. Cooking guide times and heat settings are suggestions, chosen to help prevent overcooking, the most common problem in getting used to a this oven. Variations in the size, shape, weight and dimensions of the food require longer cooking time. Use your own judgement along with the cooking guide suggestions to test food condition, just as you would do with a conventional cooker.

Technical Specifications

Technical Specification

		MA3281T
Power Input		240 V~ 50 Hz
Output		700 W (IEC60705 rating standard)
Microwave Frequency		2450 MHz
Outside Dimension		527 mm(W) X 390 mm(H) X 472 mm(D)
Power	Microwave	1200 watt
	Grill	2000 watt
Consumption	Convection	2300 watt
	Combination	max. 2350 watt

If the supplied flexible mains cord of this appliance is damaged, it must be replaced using the special mains cord part number 6411W1A025D

Memo

Memo

Memo



FOR CUSTOMER SERVICE PLEASE CONTACT LG Service on
1300 LG CARE (1300 54 2273) AUSTRALIA or
0800 LG CARE (0800 54 2273) NEW ZEALAND

www.lg.com

LG Electronics Australia 2 Wonderland Drive Eastern Creek NSW 2766 (ABN : 98 064 531 264)

Printed in Korea