



**LG**

Life's Good

User's Guide

# ***V-NET™ ACS***

After reading, store this User's Guide in an easily accessible place for all users.

Model Name: AC Manager Plus

Model No.: PQCSSA21E0



# Explanatory Notes

## Copyrights

The contents of this User's Guide for the software AC Manager Plus are protected by international copyright and computer program protection laws. The contents of the User's Guide and the programs mentioned herein are limited to uses allowed by LG Electronics. The content can only be used and copied under adherence to the user agreement. You may not reproduce (by any means) or distribute (by any means) copies of this User's Guide or any part of it without prior approval of LG Electronics.

Copyright © 2013 LG Electronics. All rights reserved. Twin Towers 20, Yeouido, Yeongdeungpo-gu, Seoul

## Registered Trademarks

AC Manager is a registered trademark of LG Electronics. All other products and company names are trademarks of their respective owners and are used for illustrative purposes only.

# Product Features



## AC Manager Plus Configuration Integrates Easily.

- The integrated device management offers driver management, peak power control, demand control, and accumulated power divider.
- Status monitoring and control as shown in the plan.
- Operates indoor or outdoor groups on a schedule.
- Provides records of indoor use daily, weekly, or monthly.
- Report feature can be used to generate internal reports.



## Other External Equipment Controls

- Works in conjunction with external equipment such as fire alarms, key tags, and lighting.
- Ability to link with ACP



## Efficient Power Control

- Displays and manages the power usage of each room.
- Distributed power data can be saved or printed.
- Ability to control the outdoor unit capacity



## Convenient Automation

- Switches between cooling and heating to reach the desired temperature of users.

## How to Use This Guide

Please read from the beginning to the end of this User's Guide before using AC Manager Plus. Also store this guide somewhere easily accessible.

## Notations Used In This Guide

### Keyboard Notation

- Keyboard strokes used by the system are marked by boldface text in angle brackets (< >).  
Example: <**Esc**> Key
- Key combinations use the same format with the addition of a plus sign (+).  
Example: <**Ctrl+C**> Key

### Program UI Notation

- Control buttons displayed within the system are marked by boldface text in square brackets ([ ]).  
Example: [**OK**], [**Save**]
- Option titles displayed in the program are marked by boldface text.  
Example: **Start**, **Programs**

---

 MEMO

# Table of Contents

## 1 Important Safety Precautions

---

## 3 Preparation

---

### 3 Installation

- 3 – Components
- 3 – Recommended Specifications
- 4 – Installing AC Manager Plus
- 12 – Deleting AC Manager Plus (Windows 7)

### 13 Starting and Closing the Program

- 13 – Starting the Program
- 15 – Closing the Program

## 17 Using the Program

---

### 17 Control/Monitoring

- 17 – Screen Configuration and Features
- 28 – Device Control
- 29 – Monitoring Devices
- 30 – Editing the Floor Plan
- 32 – Deleting the Floor Plan

### 34 Schedule

- 34 – Creating Schedules
- 38 – Checking Schedules
- 40 – Editing Schedules
- 42 – Deleting Schedules
- 43 – View history

### 44 Auto Control

- 44 – Peak Control
- 51 – Demand Control
- 53 – Temperature limit
- 58 – Auto change over
- 63 – Time Limit
- 68 – Device interlock

### 73 Energy Monitor

- 73 – Wattage
- 75 – Running time

### 77 Report

- 77 – Working history
- 79 – Installation Status

### 80 Cycle

- 80 – Outdoor Unit
- 81 – Chiller

### 82 Set

- 82 – Device Setting
- 96 – System Setting
- 102 – User Settings

## 107 Hint

---

### 107 AC Manager Plus Complete System Diagram

- 107 – Connecting AC Manager Plus to an ACP
- 109 – Connecting AC Manager Plus to multiple ACPs

### 110 Error Codes

- 110 – Indoor Device, Ventilator or Direct Expansion Ventilator, AWHP / Hydro kit, AHU error
- 112 – Outdoor Unit Errors
- 114 – MultiV 20Hp, 30Hp, 40Hp, error
- 116 – Super Errors
- 117 – Central Controller Errors
- 117 – Chiller Errors

### 120 Pre-Tech Support Checklist

---

 **MEMO**



# Important Safety Precautions

The Important Safety Precautions shown in the following are to avoid potential injury or damage due to unexpected accidents, and to increase the lifetime of the product.



## Warning

**If you don't follow the instructions, you could be injured or even killed.**

- Keep the Lock Key out of reach of children. If a child happens to swallow it, see the doctor immediately.
- To prevent electric shock or fire, do not expose the Lock Key to water or humidity.
- Do not disassemble the Lock Key arbitrarily as it could cause electric shock.
- The Lock Key does not guarantee any use, which could result in injury or death due to impairment.



## Caution

**If you do not follow the instructions, you could have injury or property loss.**

- The Lock Key could hurt your hands. Please use extreme care when using it.
- Never remove the Lock Key when you are using AC Manager.

---

 MEMO

# Preparation

The section provides the basic information required before using AC Manager Plus.

## Installation

This section explains the pre-installation preparations for AC Manager Plus and how to install it.

### Components

AC Manager Plus packaging includes the following components as shown in the diagram. Please open the AC Manager Plus package and verify that all components are included.



AC Manager Plus  
Installation DVD (User's Guide)

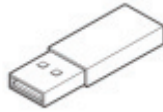

USB Authentication Key  
(Hard Lock Key)



Quick Guide



### CAUTION

If any product is used other than our standard product and a problem occurs, we don't take any responsibility regarding the problem. Please keep away from using other products.

### Recommended Specifications

The recommended specifications for AC Manager Plus are shown here.

Hardware	
CPU	Dual Core 2.4GHz or faster
System Memory	4 GB or more
Hard Disk Space	100 GB or more
OS	Windows XP, Windows 7
Resolution	1280 x 1024 or higher
Recommended Graphics	VGA: For NVidia, Geforce or later. For ATI, Radeon or later

## Installing AC Manager Plus

Install AC Manager Plus using the procedures outlined in this document.

### Hardware Installation



### AC Manager Plus Software Installation (Client/Server)

#### Hardware Installation

This section explains how to connect the computer to ACP to use AC Manager Plus.

#### Connecting AC Manager Plus to an ACP

Use these steps when installing AC Manager Plus and connecting the ACP to the same computer.

1. Connect an Ethernet cross cable to the Ethernet port of the ACP.

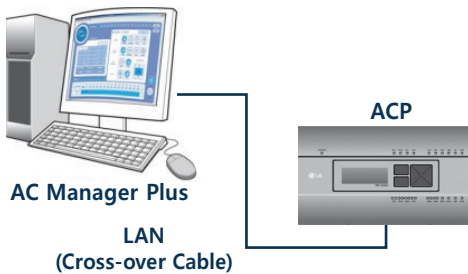

2. Connect the other end of the Ethernet cross cable to the Ethernet port of the computer.
  - You should only use an Ethernet cross cable if you are connecting the computer (AC Manager Plus) and the ACP without a hub. The ACP Ethernet terminal is located on the device as shown in the figure.

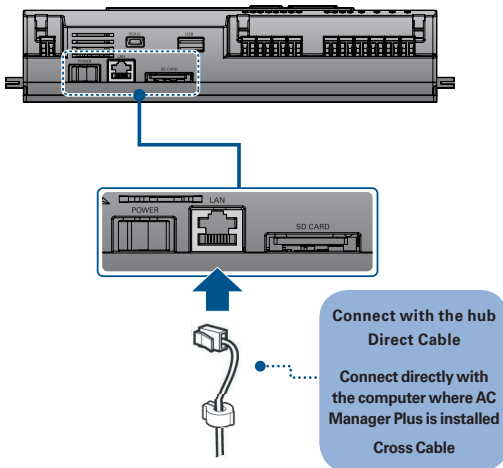

**NOTES**

Do not use the Ethernet cable before checking if it is a direct cable or cross cable. Use the LAN tester to examine the cable before connecting the cable.

**Connecting AC Manager Plus to multiple ACPs**

Use these steps when connecting AC Manager Plus to multiple ACPs by using a hub.

1. Connect each ACP to the hub with a standard Ethernet cable.

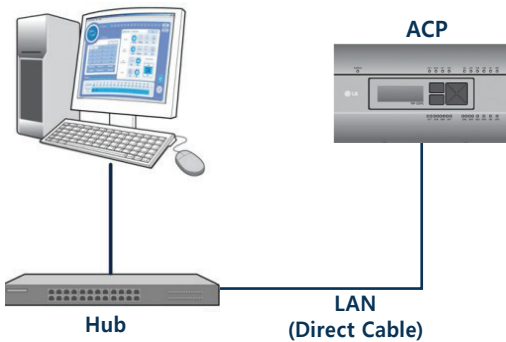
**AC Manager Plus**

## Installing AC Manager Plus ( Client )

**CAUTION**

After the software installation is complete, Lock Key must be inserted.

This section explains how to install AC Manager Plus (Client).

1. Double-click the installation icon to begin the install.
2. When the Required Components Installation window appears, click **[Install]**.
  - This will begin the installation of the required components.

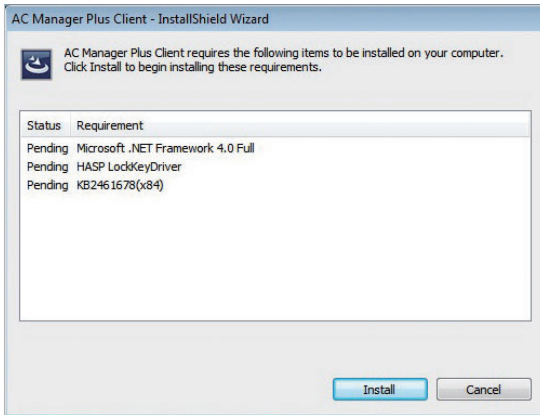

3. When the SafeNet Installation window appears, click **[Next >]**.

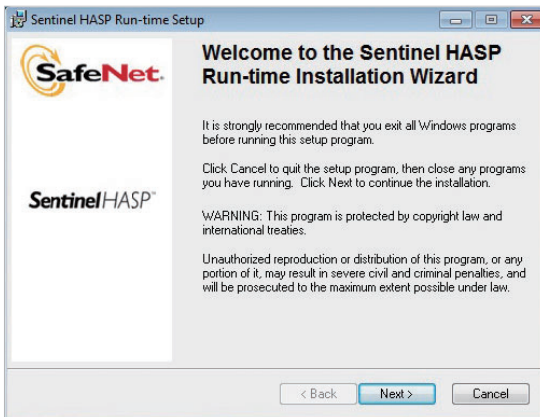

4. When the SAFENET LICENSE AGREEMENT appears, select **I accept the license agreement** and click **[Next >]**.

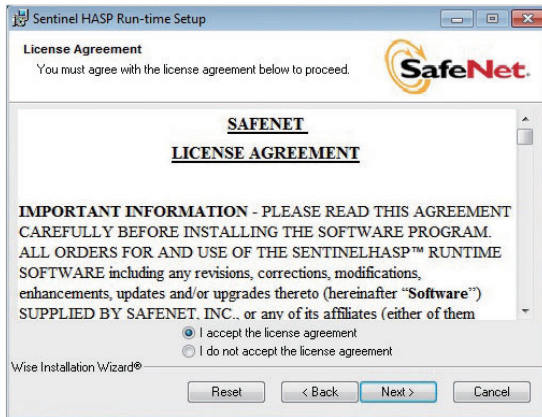

5. To proceed with the installation, click **[Next >]**.

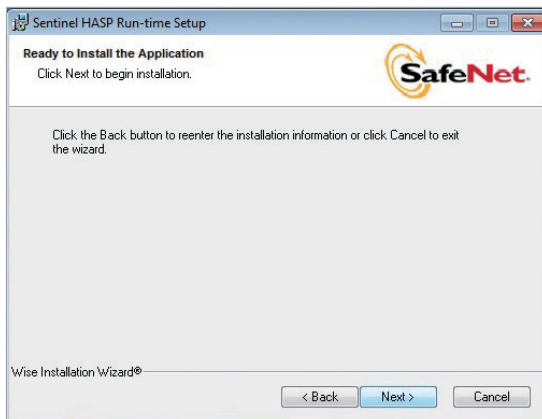

6. After the installation is complete, click **[Finish]**.
  - After installing any required components, the AC Manager Plus Client will launch the InstallShield Wizard. Please wait a moment.

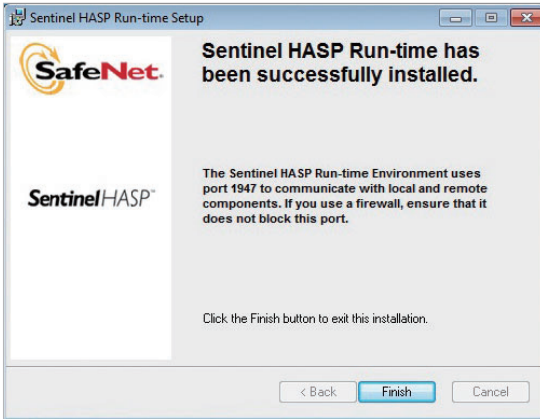

7. Once the AC Manager Plus Client InstallShield Wizard appears, click **[Next >]**.

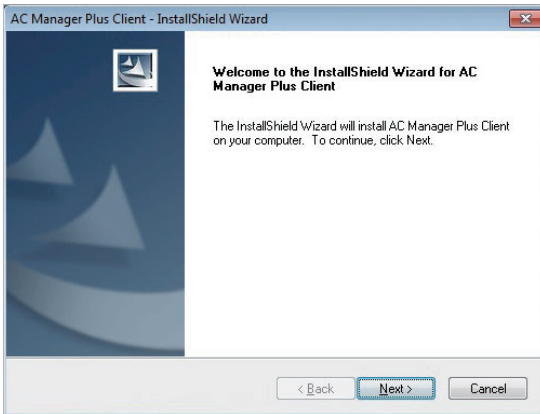



8. Enter the user information and click the **[Next >]** button.

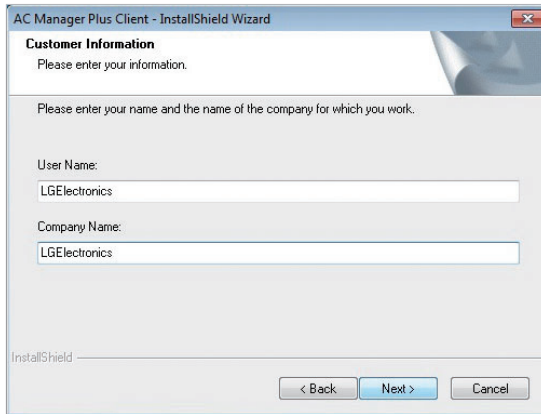

The screenshot shows the 'Customer Information' step of the 'AC Manager Plus Client - InstallShield Wizard'. The window title is 'AC Manager Plus Client - InstallShield Wizard'. The main heading is 'Customer Information' with the instruction 'Please enter your information.' Below this, a sub-instruction reads 'Please enter your name and the name of the company for which you work.' There are two text input fields: 'User Name:' containing 'LGElectronics' and 'Company Name:' also containing 'LGElectronics'. At the bottom, there are three buttons: '< Back', 'Next >', and 'Cancel'. The 'Next >' button is highlighted in blue. The 'InstallShield' logo is visible in the bottom left corner.

9. Confirm the install location of the AC Manager Plus Client and click **[Next >]**.
- If you wish to change the install location, click **[Change...]** and set the desired location.

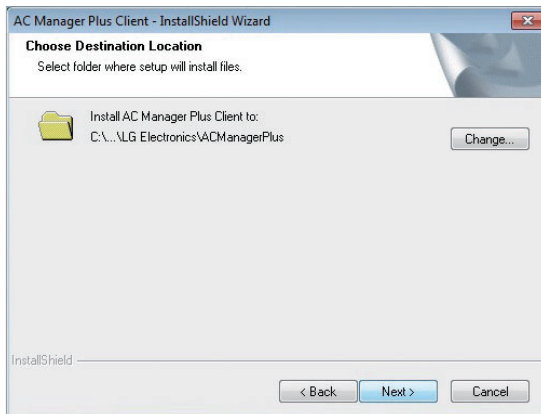

The screenshot shows the 'Choose Destination Location' step of the 'AC Manager Plus Client - InstallShield Wizard'. The window title is 'AC Manager Plus Client - InstallShield Wizard'. The main heading is 'Choose Destination Location' with the instruction 'Select folder where setup will install files.' Below this, there is a folder icon and the text 'Install AC Manager Plus Client to: C:\...LGElectronics\ACManagerPlus'. A 'Change...' button is located to the right of the path. At the bottom, there are three buttons: '< Back', 'Next >', and 'Cancel'. The 'Next >' button is highlighted in blue. The 'InstallShield' logo is visible in the bottom left corner.

**10.** To start the installation, click **[Install]**.

- The AC Manager Plus Client will now be installed.

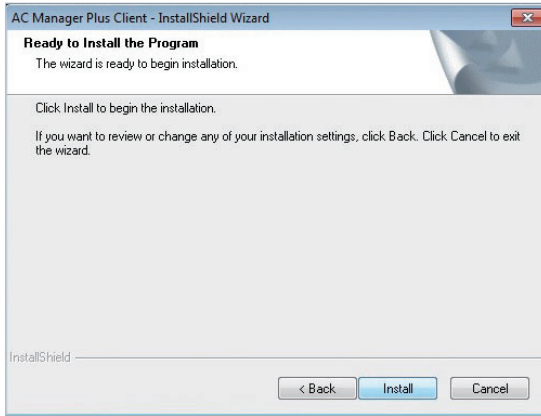
**11.** After the installation is complete, click **[Finish]**.

- Before running the program, please make sure that Windows is fully updated.

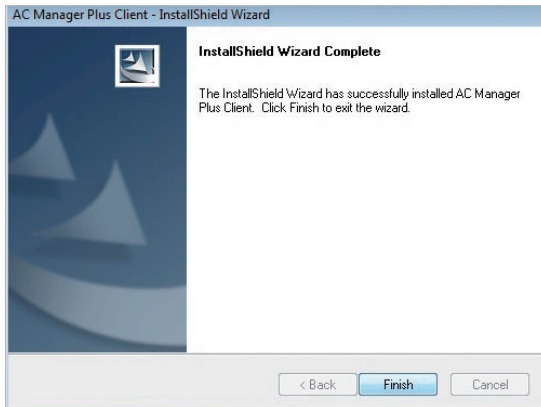

12. To restart the program, click **[Yes, I want to restart my computer now.]** and click the **[Finish]** button.

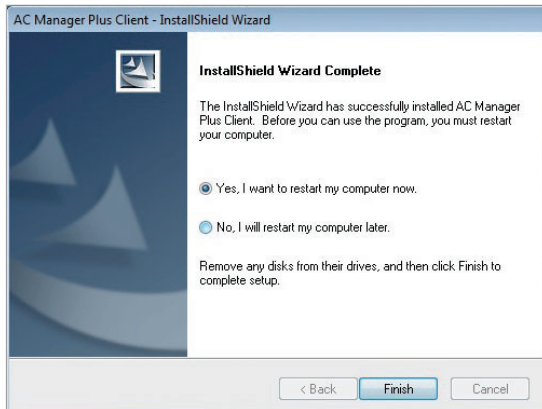

## Deleting AC Manager Plus (Windows 7)

This section explains how to delete AC Manager Plus.

1.  > **Control Panel** > **Programs** > **Programs and Features**.
2. In the Uninstall or change a program window, highlight **AC Manager Plus Client** and click **[Uninstall]**.

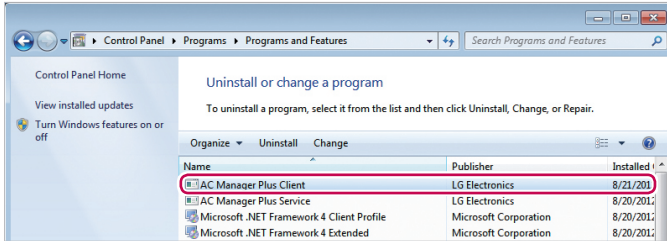

3. When you are prompted to confirm the removal, click **[Yes]**.

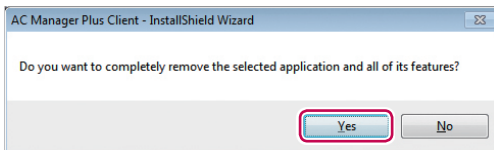

4. When the completion window appears, click **[Finish]**.

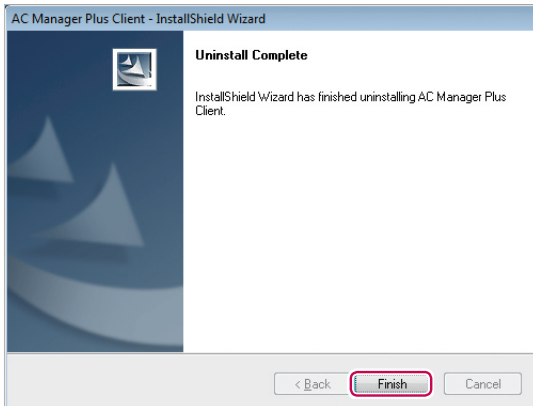

5. You may be required to restart your system.



### NOTES

If you delete AC Manager Plus, all data will also be deleted.

# Starting and Closing the Program

This section explains how to start and close AC Manager Plus.

## Starting the Program

This section explains how to start AC Manager Plus.

1. Connect the authentication key to a USB port on the computer with AC Manager Plus.
  - If you attempt to start the program without the authentication key attached, a warning appears. Insert the authentication key and start the program again.



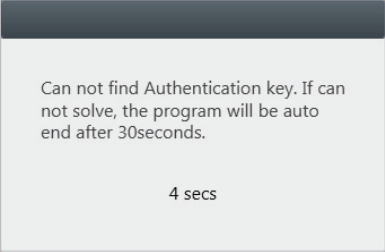

### NOTES

- All functions of AC Manager Plus are determined by the approval of the authentication key. Do not remove the authentication key from the computer while operating AC Manager Plus.
- If the authentication key is removed while operating the program, the following warning message pop ups. If you insert the authentication within 30 seconds, the warning window is turned off and the program begins to operate normally.



Can not find Authentication key. If can not solve, the program will be auto end after 30seconds.

4 secs

2.  > **All Programs > LG Electronics > AC Manager Plus Client > Executing AC Manager Plus.**
  - Alternatively, double-click the shortcut icon  on your desktop.
  - AC Manager Plus Program will start.
3. In the login window, click **[Enter server information]**.

4. After entering the server's IP address, click **[Save]**.
  - This IP address may vary depending on which computer you are logging in from. If this is the server PC, enter the loopback address (127.0.0.1). If this is a client PC, enter the IP address of the server PC.

Enter server information

Need to set server 1 time IP initially.  
If server IP changed, re-enter the IP and press the Save button.  
Enter the blank space.

IP  .  .  .

Save Cancel

5. After entering your ID and password in the login window, click **[Login]**.

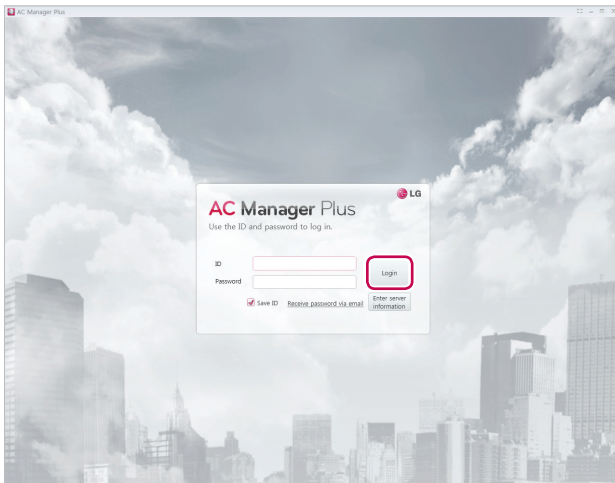

## NOTES

The administration login information of AC Manager Plus is as follows.

ID: admin, password: digital21

Use the above information for the first time login and, once logged in, change the password.

## Closing the Program

You can exit and close AC Manager Plus as follows.

1. From the AC Manager Plus program, click the **[X]** in the right top corner.

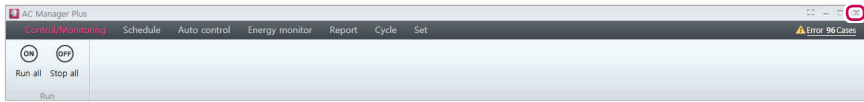

---

 MEMO



# Using the Program

This section explains how to use AC Manager Plus.

## Control/Monitoring

This section explains how to control the device and monitor the control status of the device.

### Screen Configuration and Features

The screen configuration and features of the Control/Monitoring menu screen are as follows.

No.	Item
①	Toolbars
②	Device List Tab
③	Content Display
④	Summary Display

**Toolbars**

This section explains the toolbars of the Control/Monitoring menu.

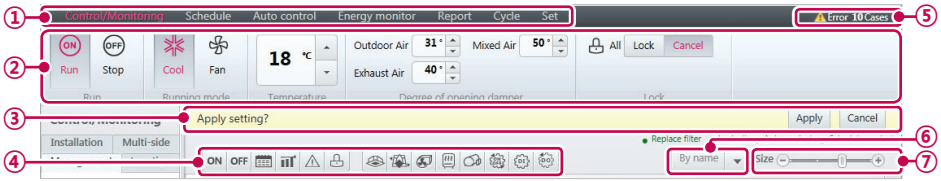

No.	Item	Description
①	AC Manager Plus Menu Tab	Service Menu for AC Manager Plus.
②	Toolbox Controls	Changes according to devices attached and other variables. (For more information, refer to the <b>Toolbox Controls per Device</b> on page 20.)
③	Apply/Cancel	Changes in the control status triggers this.
④	Content Filter Button	<p>Allows you to filter content in the Content Display area by device type or status. Click the boxes of each filter to see or hide the corresponding content.</p> <ul style="list-style-type: none"> <li> : Show active devices.</li> <li> : Show inactive devices.</li> <li> : Show devices with a schedule.</li> <li> : Show devices controlled by peak and demand.</li> <li> : Show devices with errors.</li> <li> : Show devices in need of a filter replacement.</li> <li> : Show devices with lock settings.</li> <li> : Show indoor devices.</li> <li> : Show devices with ventilators or direct expansions.</li> <li> : Show AHU devices.</li> <li> : Show AWHP / Hydro kit devices.</li> <li> : Show Chiller devices.</li> <li> : Show On/Off devices.</li> <li> : Show DI devices.</li> <li> : Show DO devices.</li> </ul>
⑤	Error Alarm	<ul style="list-style-type: none"> <li>Shows the number of devices with errors.</li> <li>When selected, it changes to <b>Report &gt; Working history</b>.</li> </ul>

No.	Item	Description
⑥	Sort Selection	<ul style="list-style-type: none"><li>• <b>By name:</b> Sorts the devices by their names.</li><li>• <b>By address:</b> Sorts the devices by their addresses.</li><li>• <b>By device:</b> Sorts by equipment type.</li><li>• <b>Whether running:</b> Sorts by status; "On", "Error", or "Off".</li></ul>
⑦	Minimize/Enlarge Device Icon slider	[-] or [+] keys or use the slider to change the size

### Toolbox Controls per Device

registered device, the menu of the toolbox controls may differ. The following explains the toolbox controls per device.



#### NOTES

The exact control limit for a device may differ from the actual device. Please be sure to refer to the manual for the device.

### Indoor Device

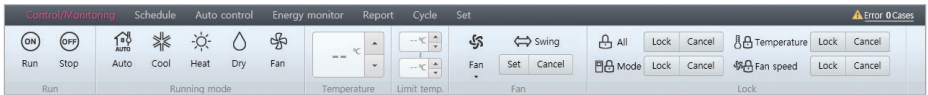

Item	Description
Run	<ul style="list-style-type: none"> <li>• <b>[Run]</b> Button: Starts the operation of the device.</li> <li>• <b>[Stop]</b> Button: Stops the operation of the device.</li> </ul>
Running mode	<ul style="list-style-type: none"> <li>• <b>[Auto]</b> Button: Changes to Auto Mode.</li> <li>• <b>[Cool]</b> Button: Changes to Cooling Mode.</li> <li>• <b>[Heat]</b> Button: Changes to Heating Mode.</li> <li>• <b>[Dry]</b> Button: Dehumidifies during rainy seasons or whenever humidity is high. You cannot set the temperature in this mode.</li> <li>• <b>[Fan]</b> Button: Purifies the air. You cannot set the temperature in this mode.</li> </ul>
Temperature	Click <b>[▲]/[▼]</b> to set the temperature.
Limit temp.	Click <b>[▲]/[▼]</b> to set the temperature limit. This prevents a user from setting the indoor temperature outside the defined range.
Fan	<ul style="list-style-type: none"> <li>• <b>Fan</b>: Selects the fan speed. <ul style="list-style-type: none"> <li>- <b>[Auto]</b> Button: Loops from Low to Medium to High</li> <li>- <b>[High]</b> Button: Fast fan speed.</li> <li>- <b>[Mid]</b>: Medium fan speed.</li> <li>- <b>[Low]</b> Button: Slow fan speed.</li> </ul> </li> <li>• <b>Swing [Set/Cancel]</b> Button: Turn on or off automatic oscillation of the fan.</li> </ul>
Lock	<ul style="list-style-type: none"> <li>• <b>All [Lock/Cancel]</b> Button: Enables/disables remote control for all features.</li> <li>• <b>Mode [Lock/Cancel]</b> Button: Enables/disables remote control for mode selection.</li> <li>• <b>Temperature [Lock/Cancel]</b> Button: Enables/disables remote control for temperature setting.</li> <li>• <b>Fan speed [Lock/Cancel]</b> Button: Enables/disables remote control for fans.</li> </ul>

## Ventilator or Direct Expansion Ventilator



Item	Description
Run	<ul style="list-style-type: none"> <li>• <b>[Run]</b> Button: Starts the operation of the device.</li> <li>• <b>[Stop]</b> Button: Stops the operation of the device.</li> </ul>
Running mode	<ul style="list-style-type: none"> <li>• <b>[Auto]</b> Button: Changes to Auto Mode.</li> <li>• <b>[Heat exchange]</b> Button: Air supply and emissions are all ventilated through the heat exchanger.</li> <li>• <b>[Normal]</b> Button: Ventilate emissions without passing through the heat exchanger.</li> </ul>
Temperature	(Only applicable to the Direct Expansion Ventilator.) Click <b>[▲]/[▼]</b> to set the temperature.
Fan speed	<ul style="list-style-type: none"> <li>• <b>Auto</b> : Loops from Low to High to Very High <ul style="list-style-type: none"> <li>- Users cannot select this mode.</li> <li>- When set to sleep/rapid mode, fans are automatically set to <b>Auto</b> mode.</li> <li>- When sleep/rapid mode is disabled, fans are automatically set to <b>High</b>.</li> <li>- Sleep/rapid mode is disabled if <b>Very High, High, or Low</b> is selected while Auto operation mode is active.</li> </ul> </li> <li>• <b>Super High</b>: Maximum fan speed.</li> <li>• <b>High</b>: Fast fan speed.</li> <li>• <b>Low</b>: Slow fan speed.</li> </ul>
Air Conditioner	(Only applicable to the Direct Expansion Ventilator.) <ul style="list-style-type: none"> <li>• <b>[Off]</b> Button: Disables air conditioning for the Direct Expansion Ventilator.</li> <li>• <b>[Cool]</b> Button: Changes to cooling mode.</li> <li>• <b>[Auto]</b> Button: Automatically changes the mode based on indoor conditions.</li> <li>• <b>[Heat]</b> Button: Changes to heating mode.</li> </ul>
Additional function	<ul style="list-style-type: none"> <li>• <b>Quick [Set/Cancel]</b> Button: Turns Rapid feature on/off. (If Rapid is enabled, Sleep is disabled.)</li> <li>• <b>Humidifier [Set/Cancel]</b> Button: Turns the Humidify feature on/off. (Only when Air Conditioning is in Heating mode.)</li> <li>• <b>Power save [Set/Cancel]</b> Button: Turns Sleep mode on/off. (If Sleep is enabled, Rapid is disabled.)</li> <li>• <b>Heater [Set/Cancel]</b> Button: Turns the Heater feature on/off.</li> </ul>
Lock	<b>All [Lock/Cancel]</b> Button: Enables/disables remote control for all features.

**AHU**

ENGLISH

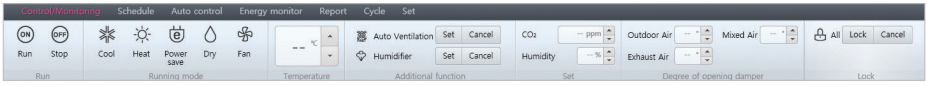

Item	Description
Run	<ul style="list-style-type: none"> <li>• <b>[Run]</b> Button: Starts the operation of the device.</li> <li>• <b>[Stop]</b> Button: Stops the operation of the device.</li> </ul>
Running mode	<ul style="list-style-type: none"> <li>• <b>[Cool]</b> Button: Changes to Cooling Mode.</li> <li>• <b>[Heat]</b> Button: Changes to Heating Mode.</li> <li>• <b>[Fan]</b> Button: Purifies the air. You cannot set the temperature in this mode.</li> <li>• Additional options will appear under Operating Modes after registering an AHU.                             <ul style="list-style-type: none"> <li>- <b>[Power save]</b> Button: Reduces energy consumption by operating in the most efficient way. Emission air is greater than air supply to emit remove air from indoors more effectively.</li> <li>- <b>[Dry]</b> Button: Dehumidifies during rainy seasons or whenever humidity is high. You cannot set the temperature in this mode.</li> </ul> </li> </ul>
Temperature	<p>Click <b>[▲]/[▼]</b> to set the temperature.</p>
Additional function	<ul style="list-style-type: none"> <li>• These options only show when add-ons for the AHU are installed.</li> <li>• <b>Auto Ventilation [Set/Cancel]</b> Button: Turns Automatic Ventilation on/off.</li> <li>• <b>Humidifier [Set/Cancel]</b> Button: Turns Humidification on/off.</li> </ul>
Settings	<ul style="list-style-type: none"> <li>• <b>CO<sub>2</sub></b>: Use <b>[▲]/[▼]</b> to set the desired carbon dioxide emissions from 500 ppm to 1,500 ppm in intervals of 100 ppm.(CO<sub>2</sub> is only settable in Auto Vent)</li> <li>• <b>Humidity</b>: Use <b>[▲]/[▼]</b> to set the desired humidity from 40% to 60% in intervals of 5% (the humidify is only settable in the humidity setting).</li> </ul>
Degree of opening damper	<ul style="list-style-type: none"> <li>• <b>Outdoor Air</b>: Use <b>[▲]/[▼]</b> to set the air intake damper opening value from 0 to 90 SDgr in intervals of 1SDgr.</li> <li>• <b>Exhaust Air</b>: Use <b>[▲]/[▼]</b> to set the emission damper opening value from 0 to 90 SDgr in intervals of 1SDgr.</li> <li>• <b>Mixed Air</b>: Use <b>[▲]/[▼]</b> to set the mixer damper opening value from 0 to 90SDgr in intervals of 1SDgr (the damper opening value is only settable in the Cooling/Heating Fan modes).</li> </ul>
Lock	<p><b>All [Lock/Cancel]</b> Button: Enables/disables remote control for all features.</p>

## AWHP / Hydro kit

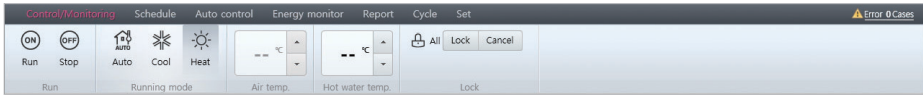

Item	Description
Run	<ul style="list-style-type: none"> <li>• <b>[Run]</b> Button: Starts the operation of the device.</li> <li>• <b>[Stop]</b> Button: Stops the operation of the device.</li> </ul>
Running mode	<ul style="list-style-type: none"> <li>• <b>[Auto]</b> Button: Changes to Auto Mode.</li> <li>• <b>[Cool]</b> Button: Changes to Cooling Mode.</li> <li>• <b>[Heat]</b> Button: Changes to Heating Mode.</li> </ul>
Outlet water temperature*	(Only operates on Cooling/Heating modes.) <ul style="list-style-type: none"> <li>• Water temperature setting for underfloor cooling and heating.</li> <li>• Click <b>[▲]/[▼]</b> to set the temperature for Cooling and Heating modes.</li> </ul>
Air Temp.*	(Only operates on Cooling/Heating modes.) Click <b>[▲]/[▼]</b> to set the indoor air temperature.
Hot water	<ul style="list-style-type: none"> <li>• <b>[Run]</b> Button: Starts the operation of the water heater.</li> <li>• <b>[Stop]</b> Button: Stops the operation of the water heater.</li> </ul>
Hot water temp.	Click <b>[▲]/[▼]</b> to set the water heater temperature.
Lock	<b>All [Lock/Cancel]</b> : Enables/disables remote control for all features.

\* When setting the AWHP device, the selected temperature is shown. (Refer to **AWHP on page 88**)

## Chiller

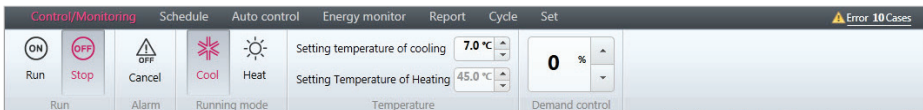

Item	Description
Run	<ul style="list-style-type: none"> <li>• <b>[Run]</b> Button: Starts the operation of the device.</li> <li>• <b>[Stop]</b> Button: Stops the operation of the device.</li> </ul>
Alarm	<b>[Cancel]</b> button: turns off the alarm issued by the unit.
Running mode	<ul style="list-style-type: none"> <li>• <b>[Cool]</b> Button: Changes to Cooling Mode.</li> <li>• <b>[Heat]</b> Button: Changes to Heating Mode.</li> </ul>
Temperature	<ul style="list-style-type: none"> <li>• Sets the Load Out temperature for indoor cooling/heating.</li> <li>• Click the <b>[▲]/[▼]</b> buttons to set the temperatures for the cooling and heating modes.</li> </ul>
Demand control	Click the <b>[▲]/[▼]</b> buttons to set the Demand Limit.

## ■ On/Off device

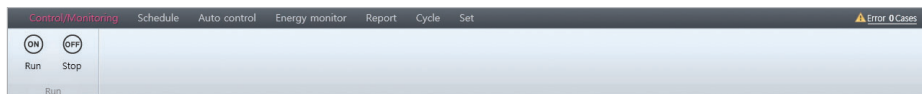

Item	Description
Run	<ul style="list-style-type: none"> <li>• <b>[Run]</b> Button: Starts the operation of the device.</li> <li>• <b>[Stop]</b> Button: Stops the operation of the device.</li> </ul>

## ■ DO

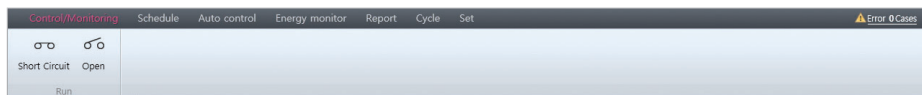

Item	Description
Run	<ul style="list-style-type: none"> <li>• <b>[Short Circuit]</b> Button: Short signal output.</li> <li>• <b>[Open]</b> Button: Open signal output.</li> </ul>



## Device List Tab

Explains the Tab of Device List.

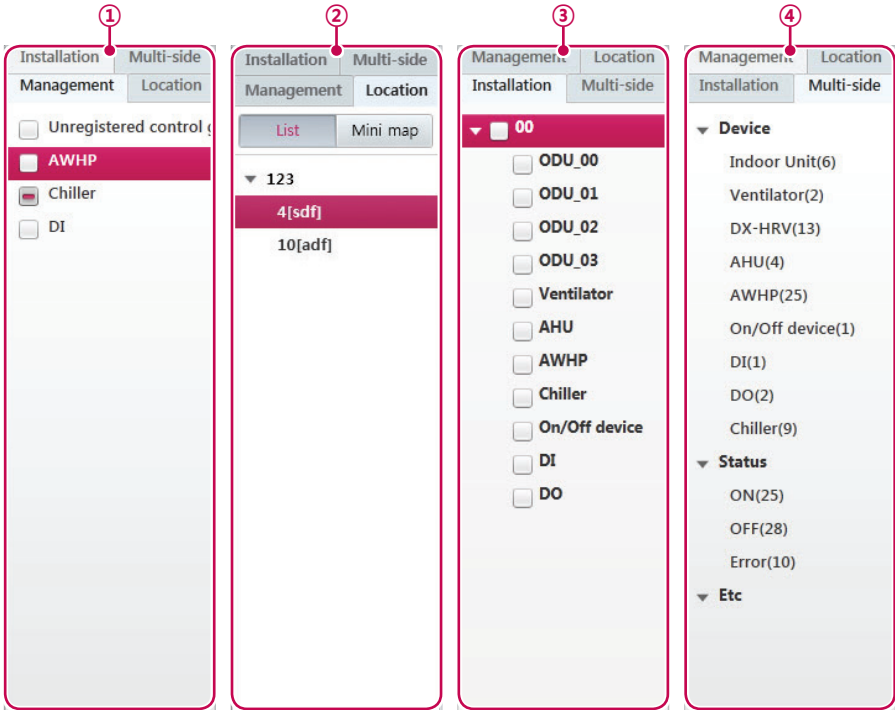



No.	Item	Description
①	Management	List of management devices for user convenience.
②	Location	<ul style="list-style-type: none"> <li>A floor plan showing control and management for each device.</li> <li>Includes a mini-map.</li> </ul>
③	Installation	Provides information on all connected devices.
④	Multi-side	<ul style="list-style-type: none"> <li>A list sorted into three groups: Devices, Status, and Other.</li> <li>Displays histories based on the selected items.</li> </ul>

**Content Display**









The setting status of a device is displayed as follows.



No.	Item	Description
①	Group Display	Displays the management group name, number of active devices, number of installed devices and number of errored devices
②	Installed Device Count	Displays the number of installed devices in each group. (Set or Cancel this under <b>Set</b> .)
③	Content Details	<ul style="list-style-type: none"> <li>• <b>Large icon</b>  <ul style="list-style-type: none"> <li>① Device status icon</li> <li>② Device icon / operation status</li> <li>③ Current temp / current temp / operation mode</li> <li>④ Device address</li> </ul> </li> <li>• <b>Medium icon</b>  <ul style="list-style-type: none"> <li>① Device status icon</li> <li>② Device icon / operation status</li> <li>③ Current temp / current temp / operation mode</li> </ul> </li> <li>• <b>Small icon</b>  <p>Device icon / operation status / operation mode</p> </li> <li>• <b>List:</b> Displays all attributes of the devices in the group.</li> </ul>

## Content Display Icons

### Device Status Icons

Icon			Status
Enlarge	Normal	Small	
	 (Green)	-	Replace filter
	 (Orange)	-	Lock all
	 (Purple)	-	Peak control
	 (Blue)	-	Schedule control

## Summary Display

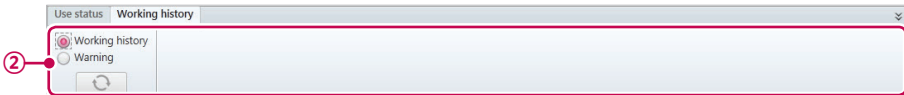
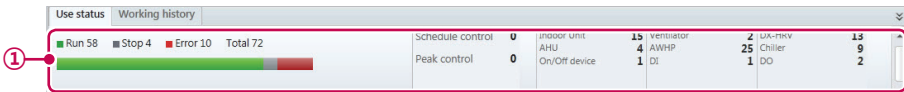

No.	Item	Description
①	Use status	Shows the current status of the selected device.
②	Working history	Shows the operation history of the device.

## Device Control

You can control the registered device by setting it to the desired state.

1. In the menu bar at the top, click **Control/Monitoring**.
2. Click the desired tab in the Device List.















Item	Description
Management	List of management devices for user convenience.
Location	<ul style="list-style-type: none"> <li>• A floor plan showing control and management for each device.</li> <li>• Includes a mini-map.</li> </ul>
Installation	Provides information on all connected devices.
Multi-side	<ul style="list-style-type: none"> <li>• A list sorted into three groups: Devices, Status, and Other.</li> <li>• Displays histories based on the selected items.</li> </ul>

3. Select the device you wish to manage in the list.
  - You can control multiple devices at the same time. Drag selected devices to the Content Display. Hold **<Ctrl>** to individually select multiple devices. If you want to choose all devices in a group, check the check box for the selected group. Depending on the types of devices chosen, the control box is limited.
4. Use the Toolbox to set the control state of the selected device.
5. When you have completed making changes, click **[Apply]**.

## Monitoring Devices

You can check the control state of registered devices.

1. In the menu bar at the top, click **Control/Monitoring**.
2. Click the desired tab in the Device List.
3. Click the filter button of the device type or status in the Content Display.
  - Multiple filters can be selected, excluding **ON** or **OFF**.
  - Select the content information of the corresponding part.

Item	Description
	Show active devices ( <b>OFF</b> cannot select with)
	Show inactive devices ( <b>ON</b> cannot select with)
	Show devices with a schedule.
	Show devices controlled by peak and demand.
	Show devices with errors.
	Show devices in need of a filter replacement.
	Show devices with lock settings.
	Show indoor devices.
	Show devices with ventilators or direct expansions.
	Show AHU devices.
	Show AWHP / Hydro kit devices.
	Show Chiller devices.
	Show On/Off devices.
	Show DI devices.
	Show DO devices.

4. Please see the device information in the Content Display.
  - You can reduce/enlarge the size of the device icons with the slider.
5. To set the control status details of a device, double-click its icon.
  - This moves you to the detailed information display of the selected device.
6. If you want to return to the monitoring screen, click the device list or click **[Go to Main menu]**.

## Editing the Floor Plan

You may edit the floor plan by selecting the **Location** tab in the Control/Monitoring menu.

1. In the menu bar at the top, click **Control/Monitoring**.
2. Click the **Location** tab in the Device List.
  - The floor plan opens.

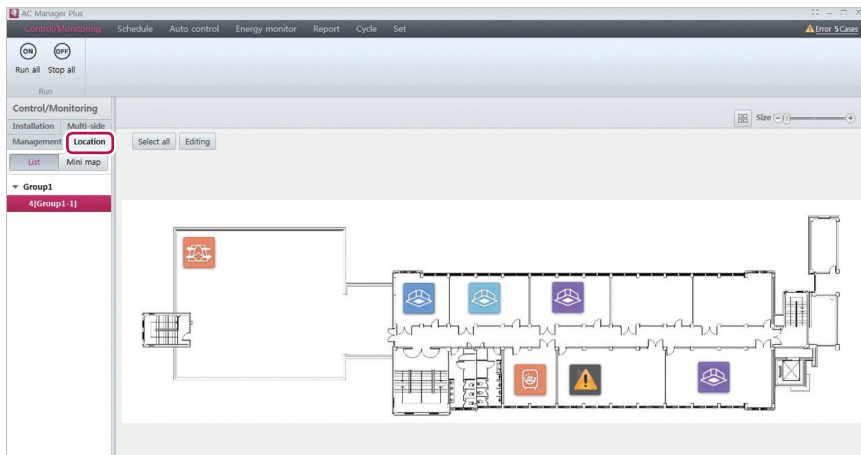

3. Click **[Editing]** button.
4. The floor plan editor opens.

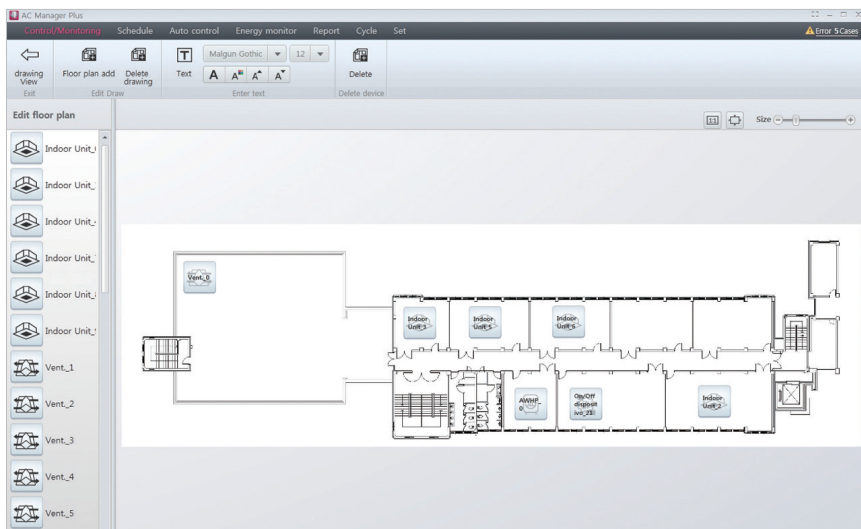

5. To add a floor plan, click **[Floor plan add]**.
6. If the file import window appears, select the floor plan file you wish to use and click **[Open]**.
  - The selected image will appear in the floor plan editor.
7. To add a device to the floor plan, select the device in the device list and drag it onto the floor plan.
8. To add or edit text on the floor plan, use the Enter Text control in the Toolbox.

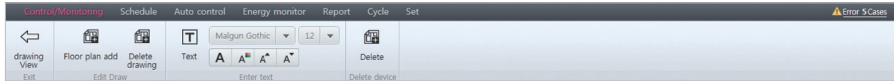

Item	Description
Enter Text	<ul style="list-style-type: none"> <li>• <b>Text:</b> Inserts a text box into the floor plan.</li> <li>• <b>Font:</b> Click [<b>▼</b>] to select the desired font from a list.</li> <li>• <b>Font size:</b> Click [<b>▼</b>] to select the desired font from a list.</li> <li>• <b>Bold:</b> Change the text to boldface.</li> <li>• <b>Color:</b> Select the desired font color from a palette.</li> <li>• <b>Larger:</b> Increases the font size by 1 pt.</li> <li>• <b>Smaller:</b> Decreases the font size by 1 pt.</li> </ul>

9. When you have completed making changes, click **[Apply]**.
10. To move to the main floor plan screen, click **[drawing View]**.



## NOTES

- To add a floor plan, you can only use jpg, bmp or png format.
- To add a floor plan, 2MB or less image size is recommended. If the size is exceeded, the alarm popup appears.

## Deleting the Floor Plan

You can delete the added floor plan.

1. In the menu bar at the top, click **Control/Monitoring**
2. Click the **Location** tab in the Device List.
  - The floor plan opens.

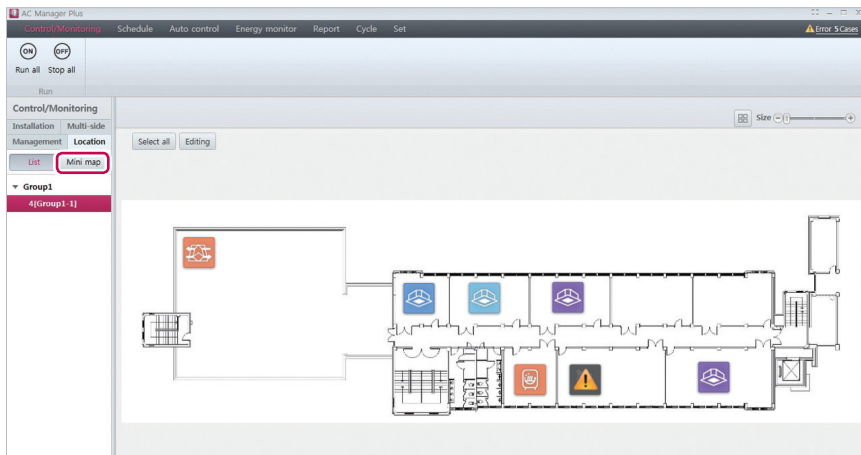

3. Click **[Editing]** button.
  - The floor plan editor opens.

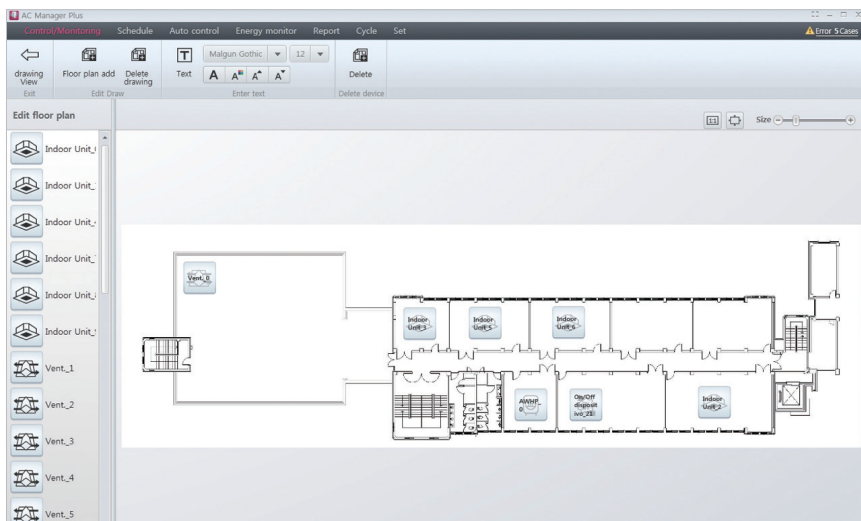



4. To delete a floor plan, click **[Delete drawing]**.
  - The floor plan is deleted.

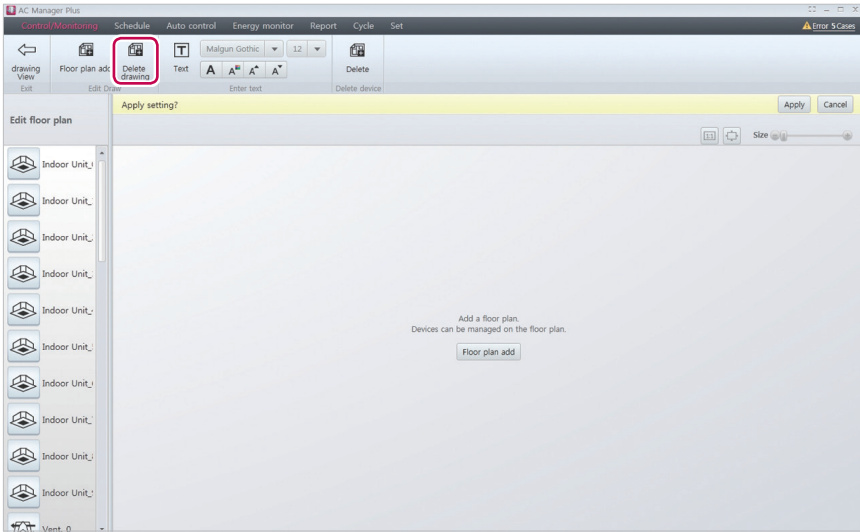

## Schedule

The Schedule feature allows you to program the behavior of the devices. If a device must adhere to a certain schedule, you can program the device to operate only at scheduled times. Scheduled devices do not activate unless programmed to do so and are managed centrally. This can significantly reduce energy consumption.

### Creating Schedules



Follow these steps to add a schedule.

1. In the menu bar at the top, click **Schedule**.
2. From the Toolbox, click **[New schedule]**.
  - The new schedule screen opens.

The screenshot shows the 'AC Manager Plus' software interface. The 'Schedule' window is open, displaying configuration options for a device named 'LGE2'. The interface is divided into several sections:

- Repeat:** Options for 'Start date' (2013-03-16), 'Repeat' (Everyday, Every, Once, End date is not designated, Designate end date), and 'Repeated date' (Mon, Tue, Wed, Thu, Fri, Sat, Sun).
- Exception date:** A table with columns for 'Exception date' and 'Load saved data'. It contains two entries: 2012-12-22 (dayoff) and 2012-12-24 (dayoff2).
- Registered device:** A table listing devices with columns for Type, Device name, Address, ACP, Control group, and Location. The table contains five entries for AWHP devices.
- Event:** Configuration for two events. Each event includes a timer, a device name ('AWHP & Hydro kit'), and various control buttons (Run, Stop, Auto, Cool, Heat, Air temp., Hot water, Hot water temp., Lock).

Red annotations highlight key elements: 1 points to the 'Save schedule?' button, 2 points to the 'Exception date' table, 3 points to the 'Registered device' table, and 4 points to the 'Event' configuration area.

No.	Item	Description
①	Name & Schedule	Set the schedule name, start date, end date, and days of operation.
②	Exception date	Manage exception days.
③	Device List	<ul style="list-style-type: none"> <li>• Displays information on registered devices.</li> <li>• <b>[Edit device]</b> Button: Add or delete a device.</li> </ul>
④	Events	<ul style="list-style-type: none"> <li>• Create events for the selected device.</li> <li>• <b>Entering Times</b> <ul style="list-style-type: none"> <li>- Click <b>[▲]/[▼]</b> to set the time.</li> <li>- Valid entries are in the 00:00 - 23:50 range in 10 minute intervals.</li> </ul> </li> <li>• <b>Device Settings</b> <ul style="list-style-type: none"> <li>- The available device tabs depend on the device selected in the Device List. Use these controls to set behavior.</li> </ul> </li> <li>• <b>[Add event]</b> Button: Create an additional event.</li> <li>•  Button: Copies the current event.</li> <li>•  Button: Deletes the current event.</li> </ul>

3. Enter a name for the schedule in the window.
4. Click the start date to select a day from a calendar.
5. Select the desired end date.

Item	Description
Once	<ul style="list-style-type: none"> <li>• Apply the schedule on the start date and no other days.</li> <li>• You cannot specify repeat days with this setting.</li> </ul>
End date is not designated	This schedule repeats until ended manually.
End dates	Select the last day of operation. Click the date to open a calendar.

6. Select repeat dates to repeat the schedule.

Item	Description
Everyday	Repeat every day from the start date to the end date.
Every	Select the desired days of the week. The schedule activates on these days every week from the start date to the end date.

7. To set exception dates, click **[Load saved data]**.
  - The exception dates are imported from the system settings and displayed.
8. To manually add new exception dates, click  and select the exception dates to add.
9. Add an exception name in the name box.
10. In the Device List, click **[Edit device]**.
  - The edit device window opens.

11. In the unregistered devices list, click the group that the device you want to register belongs to and click **[◀]** button.
  - To register multiple groups at a time, tick the checkbox for the groups you want to register and click **[◀]** button.
  - The selected devices are added to the device list.

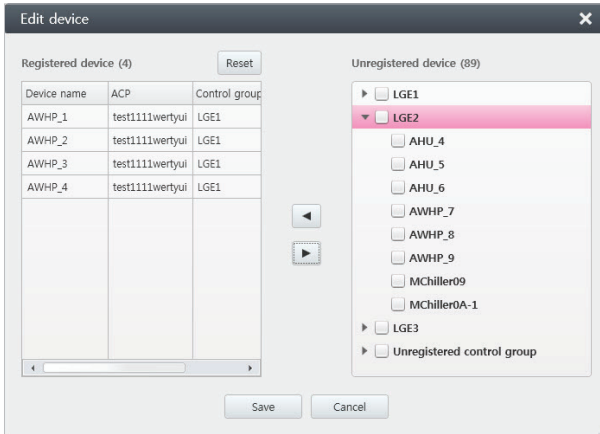

12. After registering a device, click **[Save]**.
13. To add a new event, click **[Add event]**.
14. In the Events list, use **[▲]/[▼]** to set the desired time, then select the control status.



## NOTES

Click  button to copy the previously set schedule event except time. The setup time interval for an event should be 10 minutes or longer.

15. When you have completed making changes, click **[Apply]**.

## Setting Exceptions

You can import and edit the exception dates that are already set in the system. You can also add additional exception dates.

### Importing Exceptions

You can import the exception dates that are already set in the system, as follows.

1. In the Schedule screen, click **[Load saved data]**.
  - The exception dates are imported from the system settings and displayed.
2. To save these settings, click **[Apply]**.

### Adding or Deleting Exceptions

You can add or delete exception dates as desired, as follows.

1. Add or delete exceptions dates from the Schedule screen.

No.	Item	Description
①	Delete All	Delete all listed exception dates.
②	Delete Selected	Delete the selected exception date.
③	Add Exception	<ul style="list-style-type: none"> <li>• Add an additional exception date.</li> <li>•  Select exception dates to add by clicking → Enter a name for the exception in the input box.</li> </ul>

2. To save these settings, click **[Apply]**.

## Checking Schedules

Follow these steps to check a schedule.

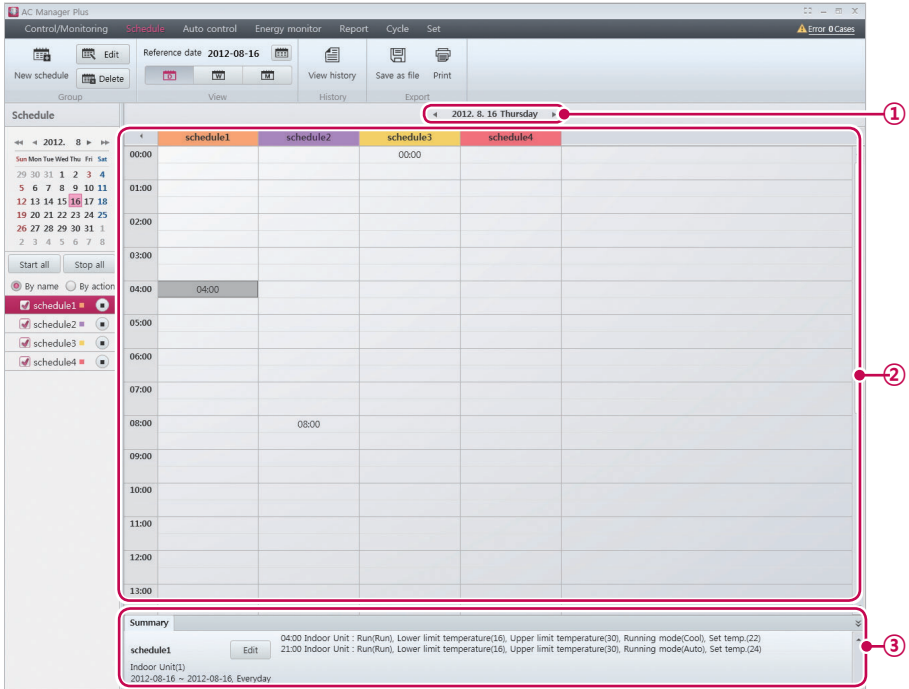

1. In the menu bar at the top, click **Schedule**.
  - The schedule screen opens.



No.	Item	Description
①	Dates	<ul style="list-style-type: none"> <li>• Shows the date currently displayed below.</li> <li>• Click [◀]/[▶] to change the currently displayed date.</li> </ul>
②	Event Display	<ul style="list-style-type: none"> <li>• Check the box to show the selected schedule.</li> <li>• Schedules are shown by color, date, and name (You cannot manually set the schedule color).</li> </ul>
③	Summary	<ul style="list-style-type: none"> <li>• A summary of the selected schedule.</li> <li>• Provides information about the schedule name, duration, repeats, and devices.</li> <li>• Displays settings according to time.</li> </ul>

2. Select the date to display on the calendar or in the Toolbox.

3. Select a viewing mode to see the schedule.

Item	Description
	Day View
	Week View
	Month View

4. Select the schedule item you wish to see from the schedule list.
- To select multiple schedules, check the box at the beginning of the list.
  - The settings screen for the selected schedules appears.
5. If you want to batch start the selected schedules, click **[Start All]**. To batch stop the selected schedules, click **[Stop All]**.
- To start a single schedule, click **[▶]** by the schedule name. To stop a running schedule, click **[■]**.
  - To save the schedule settings as a file, click **[Save as file]**. When the file save screen appears, enter a file name and click **[Save]**.
  - To print the schedule, click **[Print]**.

## Editing Schedules

You can change the settings for schedules that are currently listed.

1. In the menu bar at the top, click **Schedule**.



The screenshot shows the 'AC Manager Plus' software interface. The top menu bar includes 'Control/Monitoring', 'Schedule', 'Auto control', 'Energy monitor', 'Report', 'Cycle', and 'Set'. Below the menu bar are icons for 'New schedule', 'Edit', 'Delete', 'View history', 'Save as file', and 'Print'. The main area displays a calendar for August 2012 and a grid for editing schedules. The grid has columns for 'schedule1', 'schedule2', 'schedule3', and 'schedule4', and rows for time slots from 00:00 to 13:00. A summary section at the bottom shows details for 'schedule1', including indoor unit settings and temperature limits.

2. Select the schedule you wish to modify from the list.
3. Click **[Edit]**.
  - The schedule screen opens.



The screenshot displays the 'Schedule' configuration window for 'LGE2'. It features a sidebar with a calendar and a main content area. The 'Repeat' section allows setting a start date (2013-03-16) and selecting a repeat pattern (Once, Everyday, Every). An 'Exception date' table lists specific dates and their corresponding actions (e.g., 2012-12-22: dayoff). Below this is a 'Registered device' table with columns for Type, Device name, Address, ACP, Control group, and Location. The 'Event' section at the bottom provides real-time control for 'AWHP & Hydro kit', including buttons for Run, Stop, Auto, Cool, Heat, and temperature/pressure monitoring.

No.	Item	Description
①	Name & Schedule	Modify the schedule name, start date, end date, and days of operation.
②	Exceptions	<ul style="list-style-type: none"> <li>Manage exception days.</li> <li>• <b>[Load saved data]</b> Button: Import a list of exception dates from system settings.</li> </ul>
③	Device List	<ul style="list-style-type: none"> <li>Displays information on registered devices.</li> <li>• <b>[Edit device]</b> Button: Add or delete a device.</li> </ul>

No.	Item	Description
④	Events	<ul style="list-style-type: none"> <li>• Create events for the selected device.</li> <li>• <b>Entering Times</b> <ul style="list-style-type: none"> <li>- Click <b>[▲]/[▼]</b> to set the time.</li> <li>- Valid entries are in the 00:00 - 23:50 range in 10 minute intervals.</li> </ul> </li> <li>• <b>Device Settings</b> <ul style="list-style-type: none"> <li>- The available device tabs depend on the device selected in the Device List. Use these controls to set behavior.</li> </ul> </li> <li>• <b>[Add event]</b> Button: Create an additional event.</li> <li>•  Button: Copies the current event.</li> <li>•  Button: Deletes the current event.</li> </ul>

4. Modify the desired schedule.
5. When you have completed making changes, click **[Apply]** .

## Deleting Schedules

Follow these steps to delete a schedule.

1. In the menu bar at the top, click **Schedule**.
2. Select the schedule to delete in the schedule list.
3. From the Toolbox, click **[Delete]**.
4. When you are prompted to confirm the deletion, click **[OK]**.
  - The selected schedule is then deleted and removed from the list.

## View history

View a history of scheduled activity in this log.

1. In the menu bar at the top, click **Schedule**.
2. From the Toolbox, click **[View history]**.
  - The log report appears.

AC Manager Plus

Control/Monitoring Schedule Auto control Energy monitor **Report** Cycle Set Error 63 Cases

Working history Installation status Report

Current Period setting 2013-02-10 2013-03-11

ACP Indoor Unit AHU All items Error  
 DO Ventilator AWH-P Temperature limit Schedu  
 DI On/Off device Chiller Group setting Device

**Working history** Number of events : 10 Date range : 2013-02-10 ~ 2013-03-11

Date time	Category	Device name	Address	Device type	Main agent	Reference Code	Detail	Location
2013-03-08 AM 10:16	Control	00	00	ACP	ACM	Schedule	Change other setting information	-
2013-03-08 AM 10:23	Control	00	00	ACP	ACM	Schedule	Change other setting information	-
2013-03-08 PM 04:22	Control	00	00	ACP	ACM	Schedule	Change other setting information	-
2013-03-08 PM 04:27	Control	00	00	ACP	ACM	Schedule	Change other setting information	-
2013-03-08 PM 04:29	Control	00	00	ACP	ACM	Schedule	Change other setting information	-
2013-03-08 PM 04:35	Control	00	00	ACP	ACM	Schedule	Change other setting information	-
2013-03-08 PM 04:35	Control	00	00	ACP	ACM	Schedule	Change other setting information	-
2013-03-08 PM 04:36	Control	00	00	ACP	ACM	Schedule	Change other setting information	-
2013-03-08 PM 04:36	Control	00	00	ACP	ACM	Schedule	Change other setting information	-
2013-03-10 PM 03:36	Control	00	00	ACP	ACM	Schedule	Change other setting information	-

3. To save the log as a file, click **[Save as file]**. When the file save screen appears, enter a file name and click **[Save]**.
4. To print the log, click **[Print]**.

## Auto Control

Auto control allows you to change power consumption or control external devices by linking to them. You can also set the indoor temperature to automatically change according to outdoor conditions or activate devices for certain periods of time.



### NOTES

If you change the control value of the device in the Auto Control mode, the existing Auto Control values are cancelled.

## Peak Control

Peak control limits the peak power consumption. You can set the target operating rate so that the total power consumption does not exceed this limit. To prevent power consumption from exceeding the limit, the system will automatically change cooling mode to fan mode and cancel heating mode.

1. In the menu bar at the top, click **Auto control**.
2. From the Toolbox, click **[Peak control]**.
  - The peak control screen opens.

The screenshot shows the 'Peak control' screen in the AC Manager Plus software. The interface includes a menu bar at the top with 'Auto control' selected, a toolbar with various icons, and a main display area. The main display area is divided into a control panel on the left and a data table on the right. The control panel includes a 'Control method' section with a progress bar and a 'Target operation rate (%)' set to 49. The data table lists various indoor units (IDU) and outdoor units (ODU) with their current status, room temperature, set temperature, and mode. Red callout boxes with numbers 1 and 2 point to the control panel and the data table respectively.

Device name	Run	Room temp.	Set temp.	Mode
All				
ODU				
IDU_11	Run	23.0°C	18.0°C	Cool
IDU_12	Stop	23.0°C	18.0°C	Cool
IDU_13	Stop	23.0°C	18.0°C	Cool
IDU_14	Stop	23.0°C	18.0°C	Cool
IDU_15	Stop	23.0°C	18.0°C	Cool
IDU_16	Run	23.0°C	18.0°C	Cool
IDU_17	Run	23.0°C	18.0°C	Cool
IDU_18	Run	23.0°C	18.0°C	Cool
IDU_19	Run	23.0°C	18.0°C	Cool
IDU_1A	Run	23.0°C	18.0°C	Cool
IDU_1B	Run	23.0°C	18.0°C	Cool
IDU_1C	Run	23.0°C	18.0°C	Cool
IDU_1D	Run	23.0°C	18.0°C	Cool
IDU_1E	Run	23.0°C	18.0°C	Cool
IDU_1F	Run	23.0°C	18.0°C	Cool
IDU_20	Run	23.0°C	18.0°C	Cool
IDU_21	Run	23.0°C	18.0°C	Cool
IDU_22	Run	23.0°C	18.0°C	Cool
IDU_23	Run	23.0°C	18.0°C	Cool
IDU_24	Run	23.0°C	18.0°C	Cool
IDU_25	Run	23.0°C	18.0°C	Cool
IDU_26	Run	23.0°C	18.0°C	Cool
IDU_27	Run	23.0°C	18.0°C	Cool
IDU_28	Run	23.0°C	18.0°C	Cool

No.	Item	Description
①	Control Info Display	<ul style="list-style-type: none"> <li>• <b>Run</b> <ul style="list-style-type: none"> <li>- <b>[Apply peak control]</b> Button: Activates peak control for the selected ACP.</li> <li>- <b>[Cancel peak control]</b> Button: Deactivates peak control for the selected ACP.</li> </ul> </li> <li>• <b>Control Methods</b> <ul style="list-style-type: none"> <li>- <b>Outdoor unit capacity control function:</b> Applies limits to outdoor units to control outdoor limits.</li> <li>- <b>Priority Control:</b> Applies limits according to the priority of each ACP.</li> </ul> </li> <li>• <b>Operation rate Bar</b> <ul style="list-style-type: none"> <li>- This graphical bar shows the current operation rate and the target operation rate of indoor units.</li> <li>- You can drag the triangle slider() to change the target operation rate.</li> </ul> </li> <li>• <b>Current operation rate (%)</b> <ul style="list-style-type: none"> <li>- Shows the percentage of currently operating units from all entire indoor ACP units (blue bar).</li> </ul> </li> <li>• <b>Target operation rate (%)</b> <ul style="list-style-type: none"> <li>- Click <b>[▲]/[▼]</b> to set the desired operation rate (green bar).</li> </ul> </li> <li>• <b>SOperation Change over time (Minutes)</b> <ul style="list-style-type: none"> <li>- Click <b>[▲]/[▼]</b> to set the time in minutes to force operation to stop.</li> <li>- You can set this from 5 to 15 minutes.</li> </ul> </li> </ul>
②	Operation Status	Shows device name, activity, current temperature, set temperature, and operation mode.

3. Select the ACP you wish to control from this list.
  - The ACP settings are then shown to the right of the list.
4. Select the control status in the control status display.
5. To apply control settings, click **[Apply]**.
  - The control settings are then saved.
6. To activate the selected group, click **[Apply peak control]** or **[▶]** next to the group name.
  - To deactivate the group, click **[Cancel peak control]** or **[■]** next to the group name.
7. To apply all peak controls to registered ACPs, click **[Apply to all]**. To disable all peak controls, click **[Cancel all]**.

**NOTES**

- Depending on the installation site specifications, either of the peak control and demand control can be selected. Go to **Set > System setting > Basic setting**. In **Select peak/demand control** select a desired control method.
- The peak control is only limited to the indoor device and you can not register other devices such as ventilator or AHU, except a indoor device.

## Editing Groups

Follow these steps to change group settings at the bottom of the ACP.

1. In the menu bar at the top, click **Auto control**.
2. From the Toolbox, click **[Peak control]** and select an ACP.
3. Click **[Edit]**.
  - The peak control group edit screen opens.

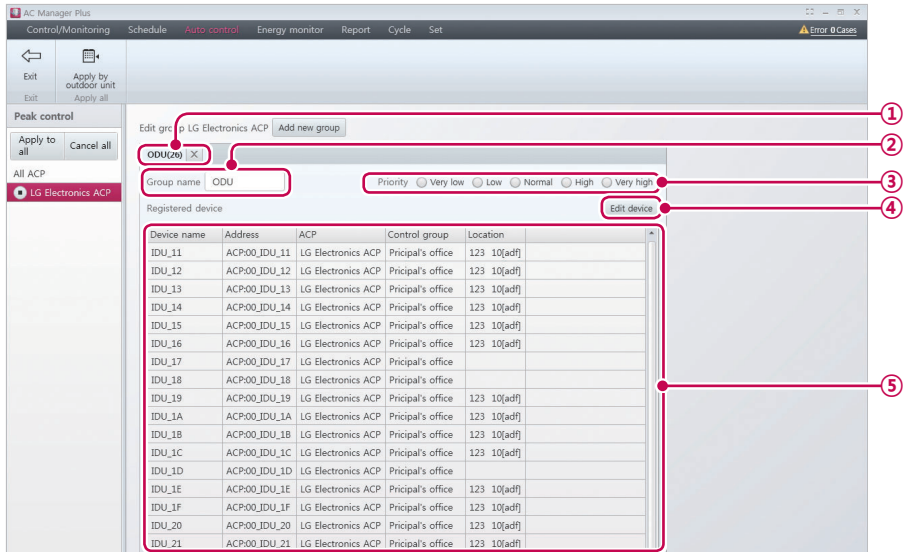

No.	Item	Description
①	Group Tabs	All registered groups are shown as tabs.
②	Group Name	Enter or modify the group name in this textbox.
③	Group Priority	Choose the priority of the group: <b>Very low</b> , <b>Low</b> , <b>Normal</b> , <b>High</b> , <b>Very high</b>
④	<b>[Edit device]</b> Button	Opens a window to edit the device list (add or remove).
⑤	Device List	Displays a list of devices registered in the selected group.

4. You can group multiple outdoor units together, or add or delete specific units from a group. Edit the selected group to your desired preferences
  - For details about grouping outdoor units, refer to **Applying to Outdoor Units** on page 48.
  - For details about adding groups, refer to **Adding Groups** on page 48.
  - For details about deleting groups, refer to **Deleting Groups** on page 49.
5. To apply control settings, click **[Apply]**.
  - The control settings are then saved.

## Applying to Outdoor Units

You can group multiple outdoor units (registered in ACP) together.

1. To apply settings to outdoor units registered to the ACP, click **[Apply by outdoor unit]**.
  - Peak control is applied to that group.
2. To save these settings, click **[Apply]**.

## Adding Groups

Follow these steps to add a new group.

1. To add a group, click **[Add group]**.
  - The add group screen opens.
2. Enter a name for the group in the group name textbox.
3. Set the priority of the group.
4. To add a device, click **[Edit device]**.
  - The edit device screen opens.
5. Check the box of unregistered devices you wish to add and click **[◀]**.
  - You can only add indoor units for peak control.
  - To add multiple devices at one time, check multiple boxes before clicking **[◀]**.
  - The selected devices are added to the device list.

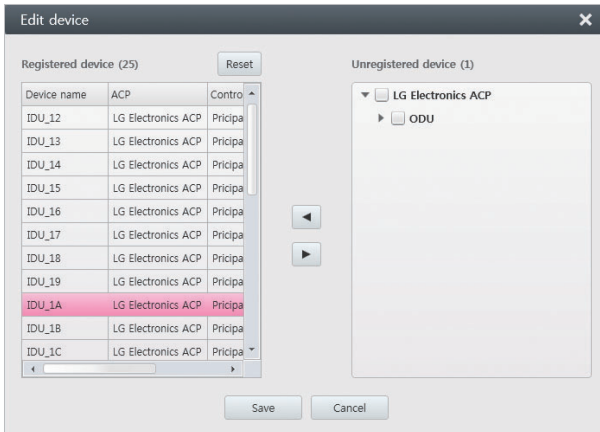

6. To accept changes to the list, click **[Save]**.
7. To save these settings, click **[Apply]**.



## Deleting Groups

Follow these steps to delete a group from the group list.

1. Click the **[X]** on the tab of the group you wish to delete.
  - The selected group is deleted and the tab removed.

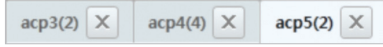

2. To save these settings, click **[Apply]**.

## Viewing the Status of Peak Controls

Follow these steps to view the status of current peak controls.

1. In the menu bar at the top, click **Auto control**
2. From the Toolbox, click **[Peak control]**, then click **[View peak control status]**.
  - The peak control status screen opens.

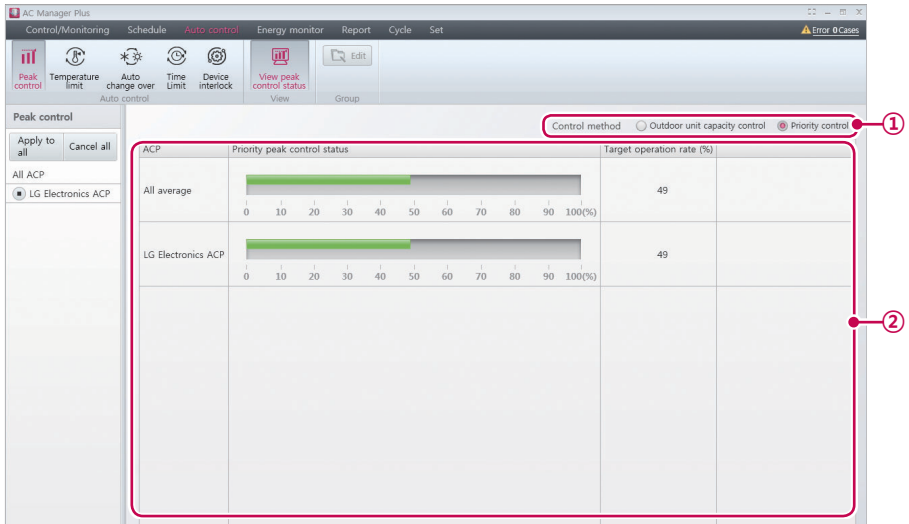

No.	Item	Description
①	Control Info Display	<ul style="list-style-type: none"> <li>• <b>Control Method</b> <ul style="list-style-type: none"> <li>- <b>Priority Control:</b> Switch to control by priority.</li> <li>- <b>Outdoor unit capacity control function:</b> Switch to control by outdoor units.</li> </ul> </li> </ul>

No.	Item	Description
②	Peak Control List	<p>(Control method when priority control is selected)</p> <ul style="list-style-type: none"> <li>• Shows a status list of peak controls for each ACP. <ul style="list-style-type: none"> <li>- <b>Priority peak control status:</b> Graphical display of current operation rates and target operation rates for each ACP.</li> <li>- <b>Current operation rate (%):</b> Displays the current operation rate of each ACP (blue bar).</li> <li>- <b>Target operation rate (%):</b> Displays the target operation rate of each ACP (green bar).</li> </ul> </li> </ul> <p>(Control method when outdoor unit control is selected)</p> <ul style="list-style-type: none"> <li>• Displays a capacity control list for outdoor units on each ACP. <ul style="list-style-type: none"> <li>- <b>Outdoor unit capacity peak control status:</b> Displays the target operation rate (%).</li> <li>- <b>Target Operation rate (%):</b> Displays target operation rate for outdoor units on each ACP.</li> </ul> </li> </ul>

## Demand Control

After observing changes in power consumption, this feature can prevent power consumption from exceeding a set limit. If you set the demand control and the program predicts that power consumption will exceed the limit, it will begin deactivating less important devices to save energy.

1. In the menu bar at the top, click **Auto control**.
2. From the Toolbox, click [**Demand control**].
  - The demand control screen opens.

The screenshot shows the 'Demand control' screen in AC Manager Plus. The 'Control method' section has 'Priority control' selected. The 'Current operating rate (%)' is 0 and the 'Target operation rate (%)' is 49. The table below lists the following devices:

Device name	Run	Room temp.	Set temp.	Mode
All				
ODU				
IDU_11	Run	23.0°C	18.0°C	Cool
IDU_12	Stop	23.0°C	18.0°C	Cool
IDU_13	Stop	23.0°C	18.0°C	Cool
IDU_14	Stop	23.0°C	18.0°C	Cool
IDU_15	Stop	23.0°C	18.0°C	Cool
IDU_16	Run	23.0°C	18.0°C	Cool
IDU_17	Run	23.0°C	18.0°C	Cool
IDU_18	Run	23.0°C	18.0°C	Cool
IDU_19	Run	23.0°C	18.0°C	Cool
IDU_1A	Run	23.0°C	18.0°C	Cool
IDU_1B	Run	23.0°C	18.0°C	Cool
IDU_1C	Run	23.0°C	18.0°C	Cool
IDU_1D	Run	23.0°C	18.0°C	Cool
IDU_1E	Run	23.0°C	18.0°C	Cool

No.	Item	Description
①	Control Info Display	<ul style="list-style-type: none"> <li>• <b>Control Method</b> <ul style="list-style-type: none"> <li>- <b>Outdoor unit capacity control:</b> Switches to a screen that offers controls based on the outdoor unit capacity limit</li> <li>- <b>Priority control:</b> Switches to a screen that offers controls based on ACP Group Priority</li> </ul> </li> <li>• <b>Operation rate bar:</b> This graphical bar shows the current operation rate and the target operation rate of indoor units.</li> <li>• <b>Current operation rate (%)</b> <ul style="list-style-type: none"> <li>- Shows the percentage of currently operating units from all entire indoor ACP units (blue bar).</li> </ul> </li> <li>• <b>Target operation rate (%)</b> <ul style="list-style-type: none"> <li>- Displays the target operation rate (green bar).</li> </ul> </li> </ul>
②	Operation Status	Shows device name, activity, current temperature, set temperature, and operation mode.

3. Select an ACP group to see its control status.
  - You can check the demand control status in the control information display and the operation status list.



## NOTES

- Depending on the installation site specifications, either of the peak control and demand control can be selected. Go to **Set > System setting > Basic setting**. In **Select peak/demand control** select a desired control method.
- You can check the demand control status and edit groups in the demand control menu. But you can not set the target operation rate, switchover, Activity Controls, and Apply All/Disable All.

## Temperature limit

The temperature limit feature allows you to maintain a certain temperature range.

- In the menu bar at the top, click **Auto control**.
- From the Toolbox, click [**Temperature limit**].
  - The temperature limit screen opens.

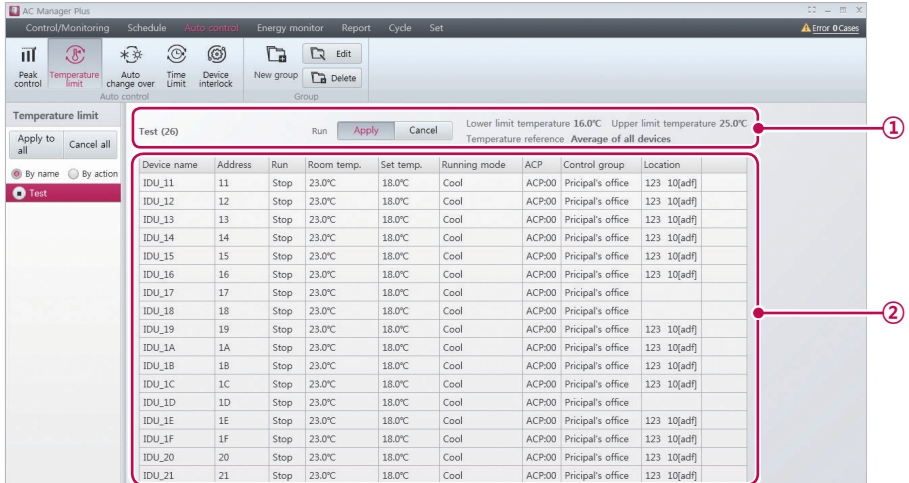

No.	Item	Description
①	Control Info Display	<ul style="list-style-type: none"> <li><b>Run</b> <ul style="list-style-type: none"> <li><b>Apply:</b> Activate the selected group.</li> <li><b>Cancel:</b> Deactivate the selected group.</li> </ul> </li> <li><b>Set temp.</b> <ul style="list-style-type: none"> <li><b>Low limit temperature:</b> The lowest temperature that is allowed indoors.</li> <li><b>Upper limit temperature:</b> The highest temperature that is allowed indoors.</li> </ul> </li> <li><b>Temperature referenc:</b> Displays the method of measuring the indoor temperature.               <ul style="list-style-type: none"> <li><b>Average of all devices:</b> The average temperature of readings from all indoor devices.</li> </ul> </li> </ul>
②	Control List	Displays a list of each registered devices and its current status.

- Select the group to apply temperature limits to in the group list.
  - The control settings status of the selected group opens.
- To activate the selected group, click [**Apply**] or the [**▶**] next to the group name.
  - To deactivate the selected group, click [**Cancel**] or [**■**] next to the group name.
- To batch start all groups, click [**Apply to all**]. To batch stop all groups, click [**Cancel All**].

## Adding Groups

Follow these steps to add a new group.

1. In the menu bar at the top, click **Auto control**
2. From the Toolbox, click **[Temperature limit]**, then click **[New group]**.
  - The add group screen opens.

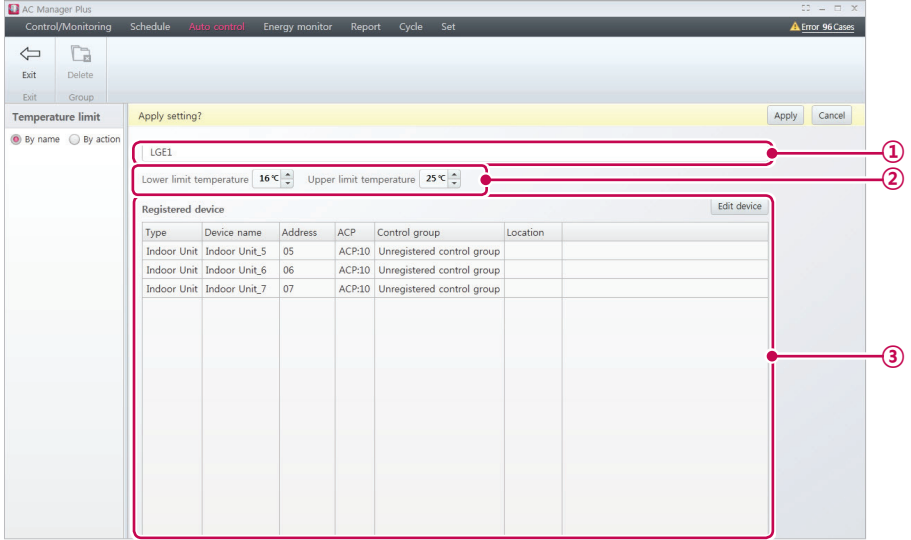

No.	Item	Description
①	Group Name	Enter or modify the group name in this textbox.
②	Set temp.	<ul style="list-style-type: none"> <li>• <b>Low limit temperature:</b> Use <b>[▲]/[▼]</b> to set the possible lowest indoor temperature.</li> <li>• <b>Upper limit temperature:</b> Use <b>[▲]/[▼]</b> to set the possible highest indoor temperature.</li> </ul>
③	Device List	<ul style="list-style-type: none"> <li>• Displays information on registered devices.</li> <li>• <b>[Edit device]</b> Button: Add or delete a device.</li> </ul>

3. Enter a name for the group in the group name textbox.
4. Click **[▲]/[▼]** to set the low and high temperature limits.
5. To add a device, click **[Edit device]**.
  - The edit device window opens.

6. Check the box of unregistered devices you wish to add and click [◀].
- You can only apply temperature limits to indoor units.
  - To add multiple devices at one time, check multiple boxes before clicking [◀].
  - The selected devices are added to the device list.

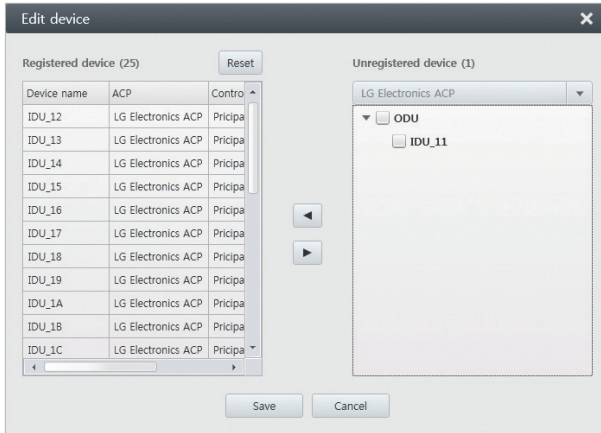

7. After registering a device, click [Save].
8. To save these settings, click [Apply].

## Editing Groups

Follow these steps to change group settings.

1. In the menu bar at the top, click **Auto control**.
2. From the Toolbox, click **[Temperature limit]**.
  - The temperature limit screen opens.
3. Select the group to modify in the group list, then click **[Edit]** in the Toolbox.
  - The edit group screen opens.

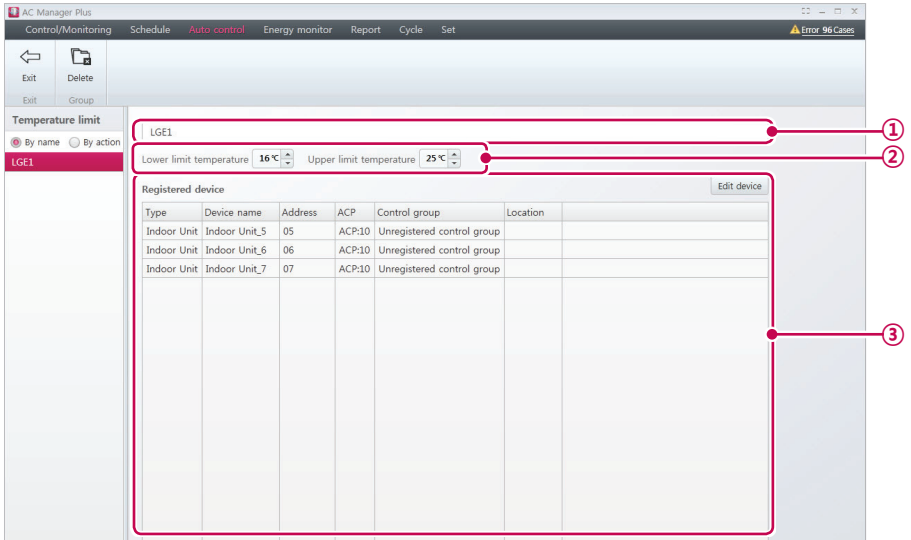

No.	Item	Description
①	Group Name	Enter or modify the group name in this textbox.
②	Set temp.	<ul style="list-style-type: none"> <li>• <b>Low limit temperature:</b> Use <b>[▲]/[▼]</b> to set the possible lowest indoor temperature.</li> <li>• <b>Upper limit temperature:</b> Use <b>[▲]/[▼]</b> to set the possible highest indoor temperature.</li> </ul>
③	Device List	<ul style="list-style-type: none"> <li>• Displays information on registered devices.</li> <li>• <b>[Edit device]</b> Button: Add or delete a device.</li> </ul>

4. Edit the selected controls to your desired preferences.
5. To save these settings, click **[Apply]**.



## Deleting Groups

Follow these steps to delete a group from the group list.

1. In the menu bar at the top, click **Auto control**.
2. From the Toolbox, click [**Temperature limit**].
  - The temperature limit screen opens.
3. Select the group to delete from the list and click [**Delete**] in the Toolbox.
4. When you are prompted to confirm the deletion, click [**OK**].
  - The selected group is deleted and removed from the list.

## Auto change over

If the temperature exceeds the high limit, the cooling system activates. If it falls below the low limit, the heating system activates.

1. In the menu bar at the top, click **Auto control**.
2. From the Toolbox, click **[Auto change over]**.
  - The auto switchover screen opens.

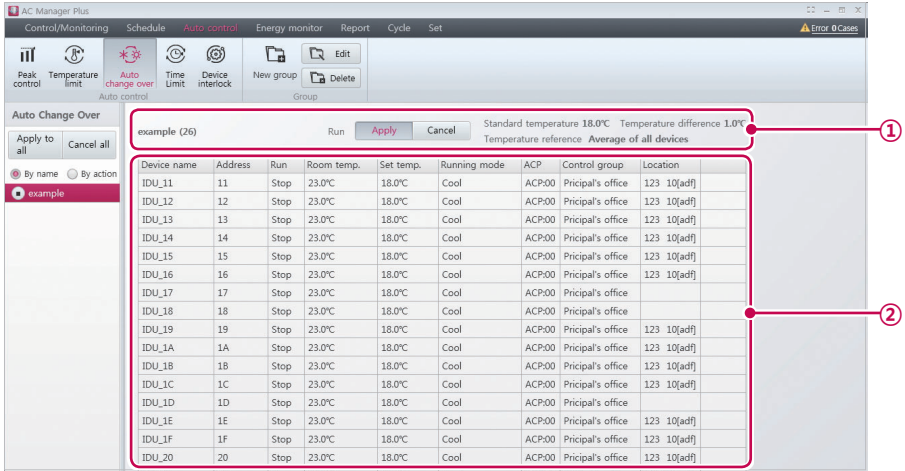

No.	Item	Description
①	Control Info Display	<ul style="list-style-type: none"> <li>• <b>Run</b> <ul style="list-style-type: none"> <li>- <b>Apply</b>: Activate the selected group.</li> <li>- <b>Cancel</b>: Deactivate the selected group.</li> </ul> </li> <li>• <b>Set temp.</b> <ul style="list-style-type: none"> <li>- <b>Standard temperature</b>: Shows the currently set indoor temperature.</li> <li>- <b>Temperature difference</b>: Shows the current temperature difference from the set temperature.</li> </ul> </li> <li>• <b>Temperature reference</b>: Displays the method of measuring the indoor temperature.               <ul style="list-style-type: none"> <li>- <b>All of all devices</b>: The average temperature of readings from all indoor devices.</li> </ul> </li> </ul>
②	Control List	Displays a list of each registered devices and its current status.

3. Select the group to apply auto switchover to in the group list.
  - The control settings status of the selected group opens.

4. To activate the selected group, click **[Apply]** or the **[▶]** next to the group name.
  - To deactivate the selected group, click **[Cancel]** or **[■]** next to the group name.
5. To batch start all groups, click **[Apply to all]**. To batch stop all groups, click **[Cancel all]**.

### Adding Groups

Follow these steps to add a new group.

1. In the menu bar at the top, click **Auto control**.
2. From the Toolbox, click **[Auto change over]**, then click **[New group]**.
  - The add group screen opens.

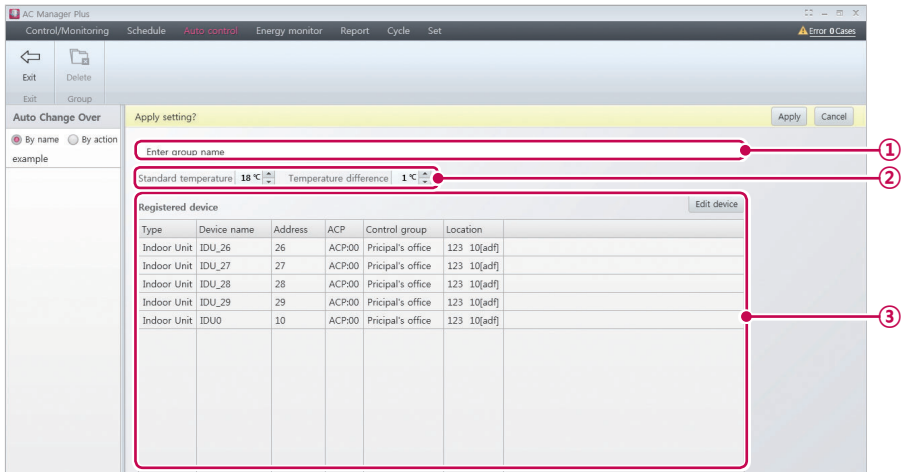

No.	Item	Description
①	Group Name	Enter or modify the group name in this textbox.
②	Set temp.	<ul style="list-style-type: none"> <li>• <b>Standard temperature:</b> Use <b>[▲]/[▼]</b> to set an allowable indoor temperature.</li> <li>• <b>Temperature difference:</b> Use <b>[▲]/[▼]</b> to set the temperature change range.</li> </ul>
③	Device List	<ul style="list-style-type: none"> <li>• Displays information on registered devices.</li> <li>• <b>[Edit device]</b> Button: Add or delete a device.</li> </ul>

3. Enter a name for the group in the group name textbox.
4. Click **[▲]/[▼]** to set the difference from the reference temperature.
5. To add a device, click **[Edit device]**.
  - The edit device window opens.

6. Check the box of unregistered devices you wish to add and click [**◀**].
  - You can only apply auto switchover to indoor units.
  - To add multiple devices at one time, check multiple boxes before clicking [**◀**].
  - The selected devices are added to the device list.

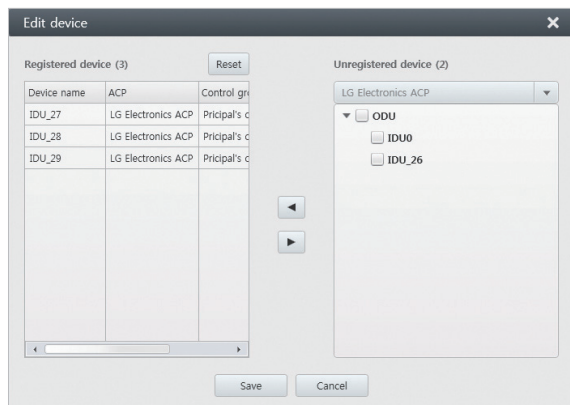

7. After registering a device, click [**Save**].
8. To save these settings, click [**Apply**].

## Editing Groups

Follow these steps to change group settings.

1. In the menu bar at the top, click **Auto control**.
2. From the Toolbox, click **[Auto change over]**.
  - The auto switchover screen opens.
3. Select the group to modify in the group list, then click **[Edit]** in the Toolbox.
  - The edit group screen opens.

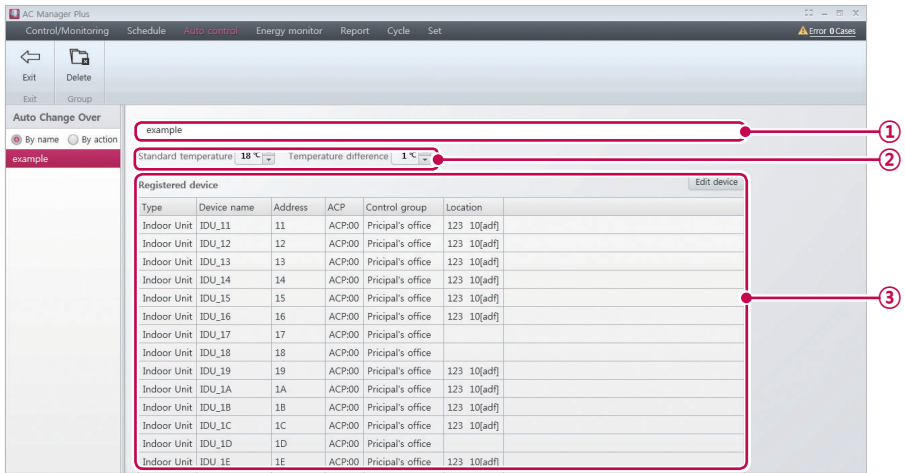

No.	Item	Description
①	Group Name	Enter or modify the group name in this textbox.
②	Set temp.	<ul style="list-style-type: none"> <li>• <b>Standard temperature:</b> Use <b>[▲]/[▼]</b> to set an allowable indoor temperature.</li> <li>• <b>Temperature difference:</b> Use <b>[▲]/[▼]</b> to set the temperature change range.</li> </ul>
③	Device List	<ul style="list-style-type: none"> <li>• Displays information on registered devices.</li> <li>• <b>[Edit device]</b> Button: Add or delete a device.</li> </ul>

4. Edit the selected controls to your desired preferences.
5. To save these settings, click **[Apply]**.

### Deleting Groups

Follow these steps to delete a group from the group list.

1. In the menu bar at the top, click **Auto control**.
2. From the Toolbox, click **[Auto change over]**.
  - The auto switchover screen opens.
3. Select the group to delete from the list and click **[Delete]** in the Toolbox.
4. When you are prompted to confirm the deletion, click **[OK]**.
  - The selected group is deleted and removed from the list.

## Time Limit

You can set limits on when devices will function.

- In the menu bar at the top, click **Auto control**.
- In the Toolbox, click **[Time Limit]**.
  - The time limit screen opens.

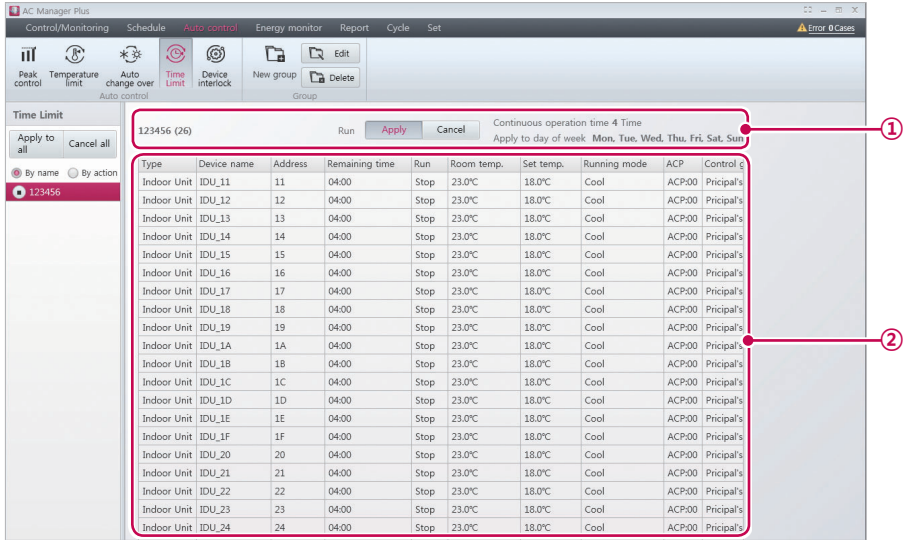

No.	Item	Description
①	Control Info Display	<ul style="list-style-type: none"> <li><b>Run</b> <ul style="list-style-type: none"> <li>- <b>Apply</b>: Activate the selected group.</li> <li>- <b>Cancel</b>: Deactivate the selected group.</li> </ul> </li> <li><b>Continuous operation time</b>: Displays continuous operation time.</li> <li><b>Apply to day of week</b>: Displays the days when the time limit is enforced.</li> </ul>
②	Control List	Displays a list of each registered devices and its current status.

- Select a group from the list.
  - The control settings status of the selected group opens.
- To activate the selected group, click **[Apply]** or the **[▶]** next to the group name.
  - To deactivate the selected group, click **[Cancel]** or the **[■]** next to the group name.
- To batch start all groups, click **[Apply to all]**. To batch stop all groups, click **[Cancel all]**.

## Adding Groups

Follow these steps to add a new group.

1. In the menu bar at the top, click **Auto control**.
2. From the Toolbox, click **[Time Limit]**, then click **[New group]**.
  - The add group screen opens.

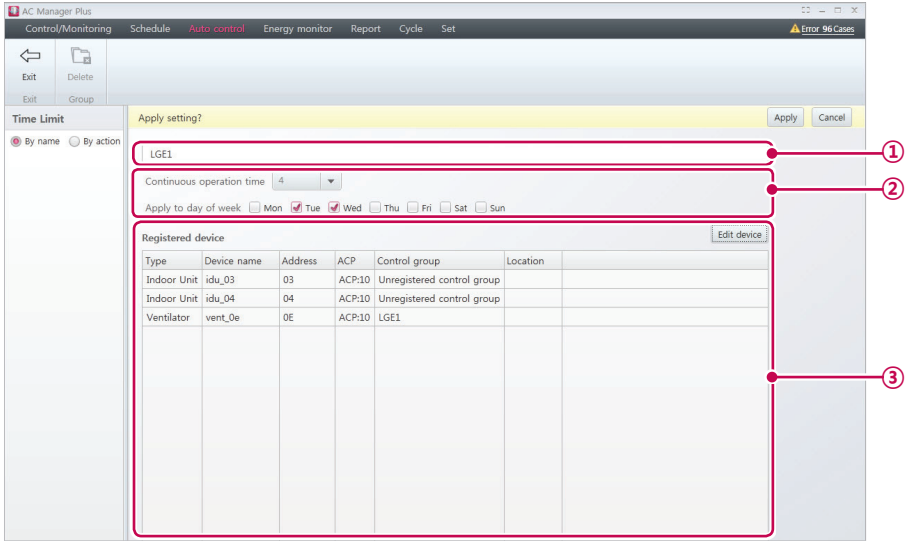

No.	Item	Description
①	Group Name	Enter a name for the group.
②	Set Time	<ul style="list-style-type: none"> <li>• <b>Continuous operation time:</b> Click <b>[▼]</b> to select the allowed uptime (1 - 4 hours).</li> <li>• <b>Apply to day of week:</b> Click the boxes to select which days have the time limit enforced. (You can select overlapping days.)</li> </ul>
③	Device List	<ul style="list-style-type: none"> <li>• Displays information on registered devices.</li> <li>• <b>[Edit device]</b> Button: Add or delete a device.</li> </ul>

3. Enter a name for the group in the group name textbox.
4. Click **[▼]** to select the allowed uptime.
5. Click on the boxes to select which days the limit is enforced.



6. To add a device, click **[Edit device]**.
  - The edit device window opens.
7. Check the box of unregistered devices you wish to add and click **[◀]**.
  - You can use time limit control on all devices except AHU, AWHP, Hydro kit, DI, DO and ON/OFF.
  - To add multiple devices at one time, check multiple boxes before clicking **[◀]**.
  - The selected devices are added to the device list.

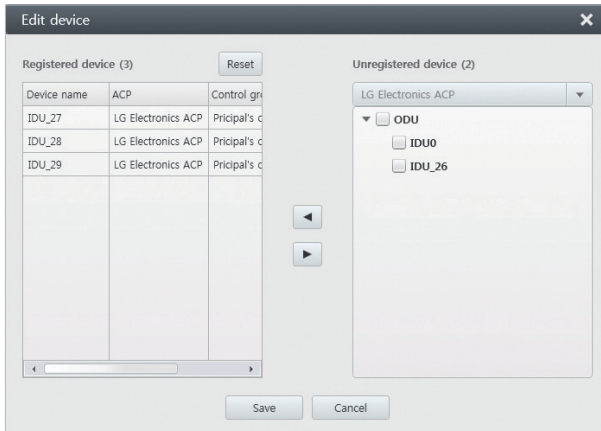

8. After registering a device, click **[Save]**.
9. To save these settings, click **[Apply]**.

## Editing Groups

Follow these steps to change group settings.

1. In the menu bar at the top, click **Auto control**.
2. In the Toolbox, click **[Time Limit]**.
  - The time limit screen opens.
3. Select the group to modify in the group list, then click **[Edit]** in the Toolbox.
  - The edit group screen opens.

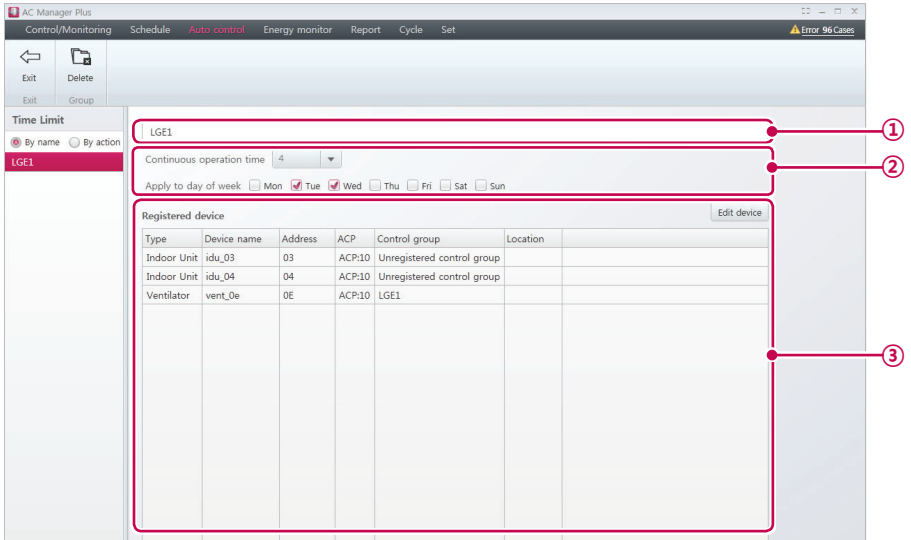

No.	Item	Description
①	Group Name	Enter or modify the group name in this textbox.
②	Set Time	<ul style="list-style-type: none"> <li>• <b>Continuous operation time:</b> Click <b>[▼]</b> to select the allowed uptime (1 - 4 hours).</li> <li>• <b>Apply to day of week:</b> Click the boxes to select which days have the time limit enforced. (You can select overlapping days.)</li> </ul>
③	Device List	<ul style="list-style-type: none"> <li>• Displays information on registered devices.</li> <li>• <b>[Edit device]</b> Button: Add or delete a device.</li> </ul>

4. Edit the selected controls to your desired preferences.
5. To save these settings, click **[Apply]**.

## Deleting Groups

Follow these steps to delete a group from the group list.

1. In the menu bar at the top, click **Auto control**.
2. In the Toolbox, click **[Time Limit]**.
  - The time limit screen opens.
3. Select the group to delete from the list and click **[Delete]** in the Toolbox.
4. When you are prompted to confirm the deletion, click **[OK]**.
  - The selected group is deleted and removed from the list.

## Device interlock

You can integrate the system with external devices, such as firealarms, to halt operation of all indoor units and ventilators.

1. In the menu bar at the top, click **Auto control**.
2. From the Toolbox, click **[Device interlock]**.
  - The device integration screen opens.

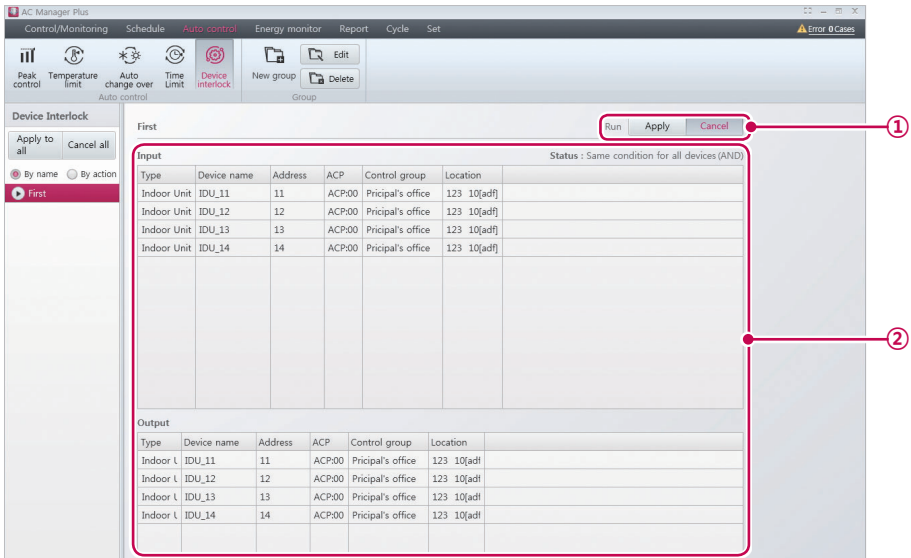

No.	Item	Description
①	Control Info Display	<ul style="list-style-type: none"> <li>• <b>Run</b></li> <li>- <b>Apply</b>: Activate the selected group.</li> <li>- <b>Cancel</b>: Deactivate the selected group.</li> </ul>
②	Control List	<ul style="list-style-type: none"> <li>• Shows input and output conditions for each action.</li> <li>• Displays the list of registered devices in the group.</li> </ul>

3. Select a group from the group list to integrate with an external device.
  - The control settings status of the selected group opens.
4. To activate the selected group, click **[Apply]** or the **[▶]** next to the group name.
  - To deactivate the selected group, click **[Cancel]** or the **[■]** next to the group name.
5. To batch start all groups, click **[Apply to all]**. To batch stop all groups, click **[Cancel all]**.

## Adding Groups

Follow these steps to add a new group.

1. In the menu bar at the top, click **Auto control**
2. From the Toolbox, click **[Device interlock]**, then click **[New group]**.
  - The add group screen opens.

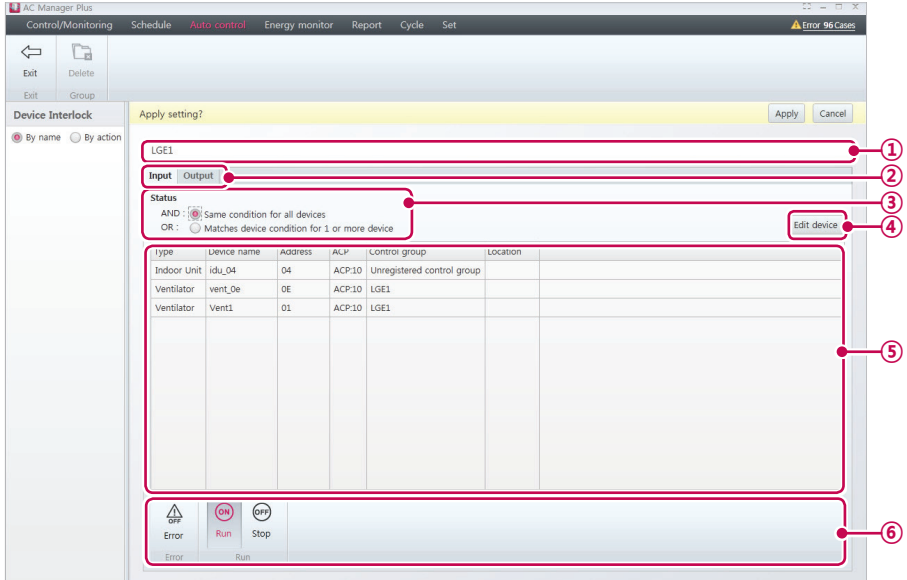

No.	Item	Description
①	Group Name	Enter a name for the group.
②	Input/Output Tabs	Inputs and outputs are separated into individual tabs.
③	Integration Conditions	Allows you to select a logical operator for the listed conditions. <ul style="list-style-type: none"> <li>• <b>AND : Same condition for all devices</b></li> <li>• <b>OR: Matches device condition for 1 or more device.</b></li> </ul>
④	<b>[Edit device]</b> Button	Add or delete a device.
⑤	Device List	Displays a list of input or output devices.
⑥	Control Toolbox	Shows settings for input/output activity on each device. <ul style="list-style-type: none"> <li>• Changes according to devices attached and other variables. (for more details, refer to <b>Toolbox Controls per Device</b> on page 20 )</li> </ul>

3. Enter a name for the group in the group name textbox.
4. Select the Input Settings tab and define the conditions for device integration.

5. To add a device, click **[Edit device]**.
  - The edit device window opens.
6. Check the box of unregistered devices you wish to add and click **[◀]**.
  - You can use Device Integration on all devices except AHU.
  - To add multiple devices at one time, check multiple boxes before clicking **[◀]**.
  - The selected devices are added to the device list.

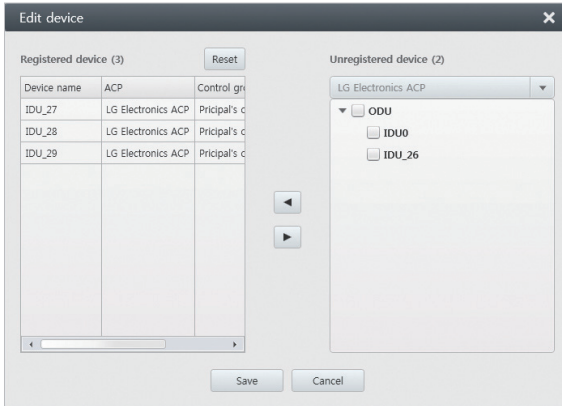

7. After registering a device, click **[Save]**.
8. Select the control status that you want in the Toolbox.
9. Select the Output Settings tab and repeat steps 5 through 8.
10. To save these settings, click **[Apply]**.

## Editing Groups

Follow these steps to change group settings.

- In the menu bar at the top, click **Auto control**.
- From the Toolbox, click **[Device interlock]**.
  - The device integration screen opens.
- Select the group to modify in the group list, then click **[Edit]** in the Toolbox.
  - The edit group screen opens.

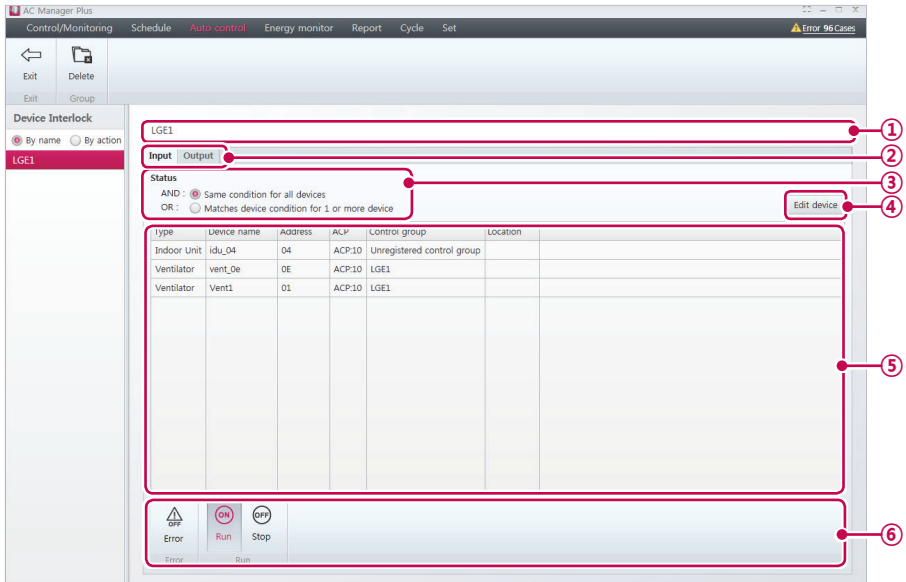

No.	Item	Description
①	Group Name	Enter or modify the group name in this textbox.
②	Input/Output Tabs	Inputs and outputs are separated into individual tabs.
③	Integration Conditions	Allows you to select a logical operator for the listed conditions. <ul style="list-style-type: none"> <li>• <b>AND : Same condition for all devices</b></li> <li>• <b>OR: Matches device condition for 1 or more device.</b></li> </ul>
④	<b>[Edit device]</b> Button	Add or delete a device.
⑤	Device List	Displays a list of input or output devices.
⑥	Control Toolbox	Shows settings for input/output activity on each device. <ul style="list-style-type: none"> <li>• Changes according to devices attached and other variables. (for more details, refer to <b>Toolbox Controls per Device</b> on page 20)</li> </ul>

- Edit the selected controls to your desired preferences.

5. To save these settings, click **[Apply]**.

### Deleting Groups

Follow these steps to delete a group from the group list.

1. In the menu bar at the top, click **Auto control**.
2. From the Toolbox, click **[Device interlock]**.
  - The device integration screen opens.
3. Select the group to delete from the list and click **[Delete]** in the Toolbox.
4. When you are prompted to confirm the deletion, click **[OK]**.
  - The selected group is deleted and removed from the list.



# Energy Monitor

## Wattage

You can check the power consumption of each group, the power consumption of an indoor unit, and total power consumption.

1. In the menu bar at the top, click **Energy monitor**.
2. From the Toolbox, click **[Wattage]**.

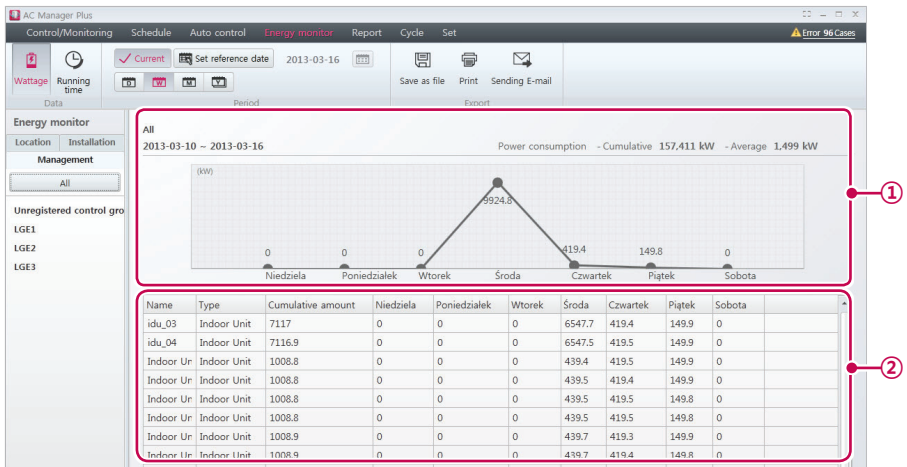

No.	Item	Description
①	Power Consumption History Graph	<ul style="list-style-type: none"> <li>• Displays the selected time period.</li> <li>• Displays cumulative and average consumption.</li> <li>• Displays history vs current for cumulative and average.</li> </ul>
②	Energy Monitor Details	Provides detailed power consumption for the registered indoor units.

3. Set the time period in the Toolbox.

Item	Description
Reference Dates	<ul style="list-style-type: none"> <li>• <b>[Current]</b> Button: Sets the current date as the reference date.</li> <li>• <b>[Set reference date]</b> Button: Allows you to select desired reference dates from a calendar.</li> </ul>
Time Scale	<ul style="list-style-type: none"> <li>• : Expands the graph across a 24 hour period.</li> <li>• : Expands the graph across a 7 day period.</li> <li>• : Expands the graph across a 30 day period.</li> <li>• : Expands the graph across a 12 month period.</li> </ul>

4. To view these settings, click **[Apply]**.
  - The power consumption for the selected period appears.
  - To save the inquiry as a file, click **[Save as file]** . When the file save screen appears, enter a file name and click **[Save]**.
  - To export the queried content to an email, press **[Export to Email]** button.
    - If the administrator accesses, **[Export to Email]** button is activated.  
In **Settings > User Settings > Mail Server Settings**, complete the **Connection Test** to send the email.
  - To print the inquiry, click **[Print]**.



## NOTES

- **[Wattage]** is only active when Power Consumption History Graph is enabled in the system settings.
- The power consumption displayed in the program may differ from the power consumption stated in the bill.
- The Energy Monitor keeps recent one-year data only.

## Running time

You can check the operating time of each group and the total operating time for indoor units.

1. In the menu bar at the top, click **Energy monitor**.
2. In the Toolbox, click **[Running time]**.

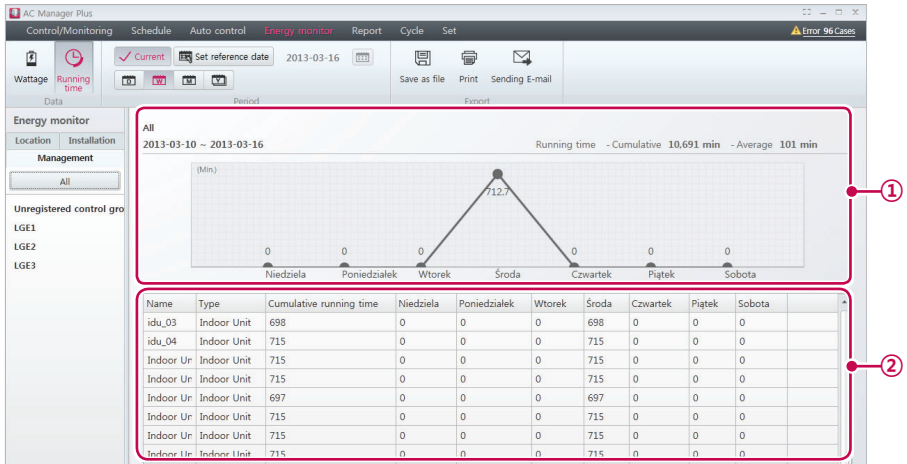

No.	Item	Description
①	Displays the selected period and operating times.	<ul style="list-style-type: none"> <li>• Displays the selected time period.</li> <li>• Displays total operating time and average operating time.</li> <li>• Displays history vs current for cumulative and average.</li> </ul>
②	Energy Monitor Details	Provides detailed operating time for the registered indoor units.

3. Set the time period in the Toolbox.

Item	Description
Reference Dates	<ul style="list-style-type: none"> <li>• <b>[Current]</b> Button: Sets the current date as the reference date.</li> <li>• <b>[Set reference date]</b> Button: Allows you to select desired reference dates from a calendar.</li> </ul>
Time Scale	<ul style="list-style-type: none"> <li>• : Expands the graph across a 24 hour period.</li> <li>• : Expands the graph across a 7 day period.</li> <li>• : Expands the graph across a 30 day period.</li> <li>• : Expands the graph across a 12 month period.</li> </ul>

**4.** To view these settings, click **[Apply]**.

- The operating time for the selected period appears.
- To save the inquiry as a file, click **[Save as file]** . When the file save screen appears, enter a file name and click **[Save]**.
- To export the queried content to an email, press **[Export to Email]** button.
  - If the administrator accesses, **[Export to Email]** button is activated.  
In **Settings > User Settings > Mail Server Settings**, complete the **Connection Test** to send the email.
- To print the inquiry, click **[Print]**.

# Report

Explains how to inquire the device operation log or installation status.

## Working history

You can generate reports on the status and activity of devices.

1. In the menu bar at the top, click **Report**.
2. From the Toolbox, click **[Working history]**.
  - The operation log screen opens.





**Working history** Number of events : 20000 Date range : 2013-03-16 ~ 2013-03-16

Date time	Category	Device name	Address	Device type	Main agent	Reference Code	Detail
2013-03-16 AM 12:00	Error	ODU_00	00	Outdoor Unit	-	Error	[CH_246] Data receipt time out error from central controller (When rec
2013-03-16 AM 12:00	Error	ODU_01	01	Outdoor Unit	-	Error	[CH_246] Data receipt time out error from central controller (When rec
2013-03-16 AM 12:00	Error	ODU_02	02	Outdoor Unit	-	Error	[CH_246] Data receipt time out error from central controller (When rec
2013-03-16 AM 12:00	Error	ODU_03	03	Outdoor Unit	-	Error	[CH_246] Data receipt time out error from central controller (When rec
2013-03-16 AM 12:00	Error	idu_03	03	Indoor Unit	-	Error	[CH_246] Data receipt time out error from central controller (When rec
2013-03-16 AM 12:00	Error	idu_04	04	Indoor Unit	-	Error	[CH_246] Data receipt time out error from central controller (When rec
2013-03-16 AM 12:00	Error	Indoor Unit_5	05	Indoor Unit	-	Error	[CH_246] Data receipt time out error from central controller (When rec
2013-03-16 AM 12:00	Error	Indoor Unit_6	06	Indoor Unit	-	Error	[CH_246] Data receipt time out error from central controller (When rec
2013-03-16 AM 12:00	Error	Indoor Unit_7	07	Indoor Unit	-	Error	[CH_246] Data receipt time out error from central controller (When rec
2013-03-16 AM 12:00	Error	Indoor Unit_8	08	Indoor Unit	-	Error	[CH_246] Data receipt time out error from central controller (When rec
2013-03-16 AM 12:00	Error	Indoor Unit_9	09	Indoor Unit	-	Error	[CH_246] Data receipt time out error from central controller (When rec
2013-03-16 AM 12:00	Error	Indoor Unit_A	0A	Indoor Unit	-	Error	[CH_246] Data receipt time out error from central controller (When rec
2013-03-16 AM 12:00	Error	Indoor Unit_B	0B	Indoor Unit	-	Error	[CH_246] Data receipt time out error from central controller (When rec
2013-03-16 AM 12:00	Error	Indoor Unit_C	0C	Indoor Unit	-	Error	[CH_246] Data receipt time out error from central controller (When rec
2013-03-16 AM 12:00	Error	Indoor Unit_D	0D	Indoor Unit	-	Error	[CH_246] Data receipt time out error from central controller (When rec
2013-03-16 AM 12:00	Error	Indoor Unit_E	0E	Indoor Unit	-	Error	[CH_246] Data receipt time out error from central controller (When rec
2013-03-16 AM 12:00	Error	실내기_0	00	Indoor Unit	-	Error	[CH_246] Data receipt time out error from central controller (When rec
2013-03-16 AM 12:00	Error	실내기_10	10	Indoor Unit	-	Error	[CH_246] Data receipt time out error from central controller (When rec
2013-03-16 AM 12:00	Error	실내기_11	11	Indoor Unit	-	Error	[CH_246] Data receipt time out error from central controller (When rec

No.	Item	Description
①	Event Count/Date Range	<ul style="list-style-type: none"> <li>• Event Count: Displays the number of events in the report.</li> <li>• Date Range: Displays the selected date range.</li> </ul>
②	Operation Log	Displays a history of operations for each device.

3. Set the time period in the Toolbox.

Item	Description
Reference Dates	<ul style="list-style-type: none"> <li>• <b>[Current]</b> Button: Sets the current date as the reference date.</li> <li>• <b>[Period setting]</b> Button: Allows you to select desired dates from a calendar to be reference dates (maximum of 1 year).</li> </ul>

Item	Description
Time Scale	<ul style="list-style-type: none"> <li>•  : Expands the graph across a 24 hour period.</li> <li>•  : Expands the graph across a 7 day period.</li> <li>•  : Expands the graph across a 30 day period.</li> <li>•  : Expands the graph across a 3 month period.</li> </ul>

4. Select the desired device and event filters in the Toolbar.
  - You can check multiple filters.
5. To view these settings, click **[Apply]**.
  - The operation log for the selected period appears.
  - To save the inquiry as a file, click **[Save as file]** . When the file save screen appears, enter a file name and click **[Save]**.
  - To print the inquiry, click **[Print]**.



## NOTES

The Reports keeps recent one-year data only.

## Installation Status

You can generate a report on device settings of the installed devices.

- In the menu bar at the top, click **Report**.
- From the Toolbox, click **[Installation status]**.
  - The installation status screen opens.

AC Manager Plus

Control/Monitoring Schedule Auto control Energy monitor **Report** Cycle Set

Working history **Installation status**

Report Device Export

Installation status Number of devices : 68

Address	Type	Device name	ACP	Control group	Location group
ACP:00	ACP	00	00	-	-
ACP:00_AHU_00	AHU	00	00	Unregistered control group	-
ACP:00_AHU_23	AHU	1111	00	Unregistered control group	-
ACP:00_AHU_11	AHU	23	00	Unregistered control group	-
ACP:00_AHU_01	AHU	ahu_01	00	Unregistered control group	-
ACP:00_AWHP_00	AWHP	AWHP_0	00	AWHP	-
ACP:00_AWHP_01	AWHP	AWHP_1	00	AWHP	-
ACP:00_AWHP_10	AWHP	AWHP_10	00	AWHP	-
ACP:00_AWHP_11	AWHP	AWHP_11	00	AWHP	-
ACP:00_AWHP_12	AWHP	AWHP_12	00	AWHP	-
ACP:00_AWHP_13	AWHP	AWHP_13	00	AWHP	-
ACP:00_AWHP_14	AWHP	AWHP_14	00	AWHP	-
ACP:00_AWHP_15	AWHP	AWHP_15	00	AWHP	-
ACP:00_AWHP_16	AWHP	AWHP_16	00	AWHP	-
ACP:00_AWHP_17	AWHP	AWHP_17	00	AWHP	-

No.	Item	Description
①	Device Count	Displays the number of devices in the report.
②	Installation Status	Displays a installation status list for all devices.

- Select the desired device filters in the Toolbar.
  - You can check multiple filters.
- To view these settings, click **[Apply]**.
  - Installation Status appears.
  - To save the inquiry as a file, click **[Save as file]**. When the file save screen appears, enter a file name and click **[Save]**.
  - To print the inquiry, click **[Print]**.

# Cycle

This tab displays the cycle information for the IDU/ODU and the Chiller.

## Outdoor Unit

1. In the menu bar at the top, click **Cycle**
2. From the Toolbox, click **[Outdoor Unit]**.
  - The outdoor unit cycle screen opens.

The screenshot shows the 'AC Manager Plus' software interface. The top menu bar includes 'Control/Monitoring', 'Schedule', 'Auto control', 'Energy monitor', 'Report', 'Cycle', and 'Set'. The 'Cycle' menu is active. On the left, the 'Outdoor Unit' and 'Chiller' options are visible. The main display area is titled 'ODU Cycle information' and shows a table of parameters for a 'Master' unit. Below this is a table titled 'Indoor unit cycle information' listing various indoor units (IDU0 to IDU19) with their running states and modes. Red callout boxes with numbers 1 and 2 point to the ODU and IDU tables respectively.

Master			
Address	09	Heat recovery temp.	49.5°C
Device type	SYNC_SUPER2	Supercooler inlet temp.	10.3°C
Mode	STOP	Overcooler outlet temp.	27.8°C
MICCOM version	0.0	Outdoor unit EEV	1344
Error code	0	Supercooler EEV	288
Inverter compressor frequency	80	Hot gas valve	Closed
Inverter FAN1 frequency	23	Inverter liquid pipe	Closed
Inverter FAN2 frequency	23	Inverter discharge temp.	83.0°C
Air temp.	29.4°C	Constant speed compressor discharge temp.	31.0°C
Target high pressure	2729	Constant speed compressor liquid valve	Closed
Target low pressure	830	Constant speed compressor	OFF
Compressor suction temp.	10.0°C	Refrigerant type	R410A
Liquid pipe temp.	42.5°C		

Device name	Running State	Running mode	Set temp.	Fan speed	Lock all	Swing	Room temp.	LEV	Inlet
IDU0	Run	Fan	25.0°C	Mid	Set	Cancel	23.0°C	0	220
IDU_11	Run	Fan	25.0°C	High	Set	Cancel	23.0°C	0	220
IDU_12	Run	Fan	25.0°C	High	Set	Cancel	23.0°C	0	220
IDU_13	Run	Fan	25.0°C	High	Set	Cancel	23.0°C	0	220
IDU_14	Run	Fan	25.0°C	High	Set	Cancel	23.0°C	0	220
IDU_15	Run	Fan	25.0°C	High	Set	Cancel	23.0°C	0	220
IDU_16	Run	Fan	25.0°C	Low	Set	Cancel	23.0°C	0	220
IDU_17	Run	Fan	25.0°C	Low	Set	Cancel	23.0°C	0	220
IDU_18	Run	Fan	25.0°C	High	Set	Cancel	23.0°C	0	220
IDU_19	Run	Fan	25.0°C	High	Set	Cancel	23.0°C	0	220

No.	Item	Description
①	Outdoor Unit Cycle Info	Displays master/slave information on outdoor units.
②	Indoor Unit Cycle Info	Displays information on all indoor units that are connected to outdoor units.

3. Select an outdoor unit in the ACP list to display cycle information.
  - The cycle information for the selected outdoor unit is displayed to the right.



## NOTES

You can only query when the installed outdoor unit provides cycle information.



## Chiller

1. In the menu bar at the top, click **Cycle**
2. From the Toolbox, click **[Chiller]**.
  - The Chiller Cycle screen opens.

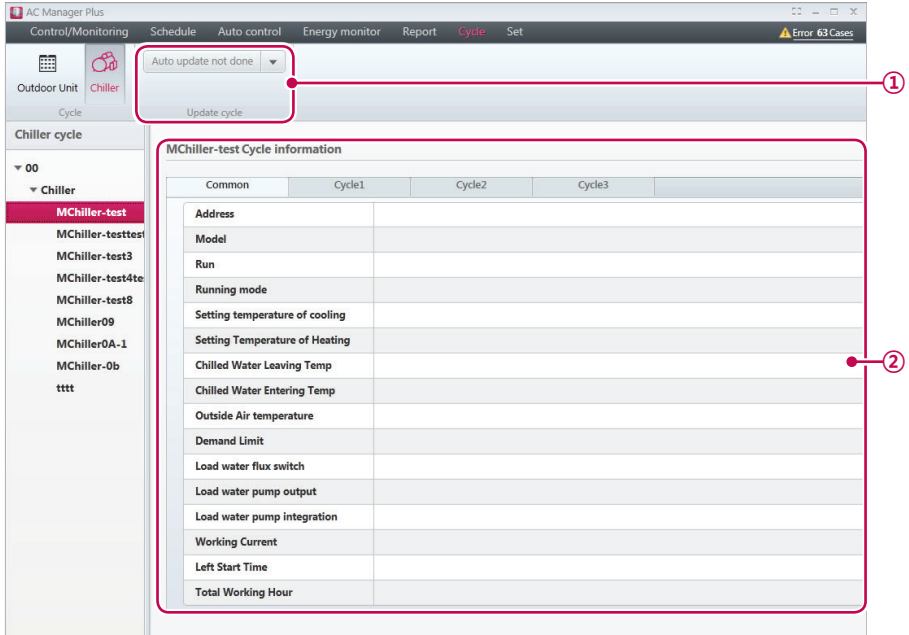

No.	Item	Description
①	Update cycle	Set Chiller Cycle's information update cycle (30 Seconds / 1 Minute / 2 Minute / 5 Minute / 10 Minute / 1 Hour / 2 Hours / Auto update not done)
②	Chiller Cycle Information	Displays the Common/Cycle information for the Chiller.

3. Select an Chiller in the ACP list to display cycle information.
  - The cycle information for the selected Chiller is displayed to the right.

## Set

This section explains how to set the device and system after installing AC Manager Plus.

### Device Setting

You can add an ACP or other device and change the settings of registered devices.



#### NOTES

Changing the settings of the device/ACP will delete the settings of the schedule and automatic control.

#### Add Device

Follow these steps to add a new device to the device list.

1. In the menu bar at the top, click **Set**.
2. From the Toolbox, click **[Device setting]**.
  - The device edit screen opens by default.

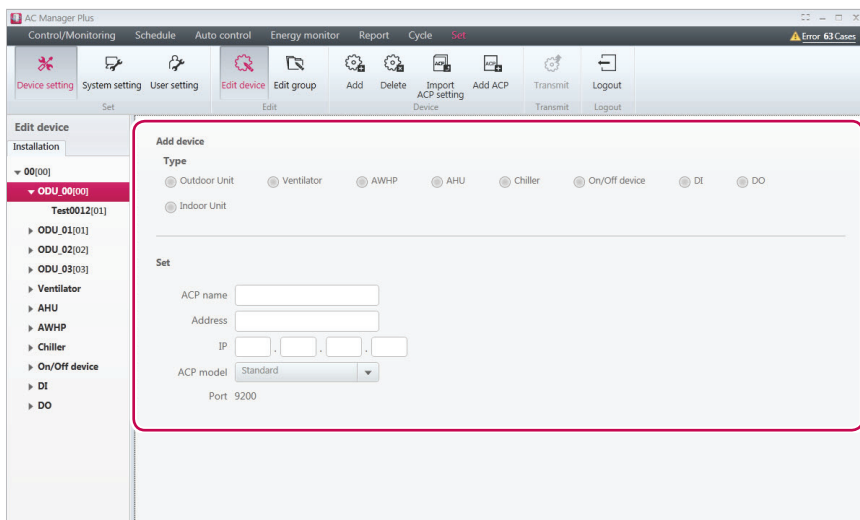

Item	Description
Type	The device type appears differently depending on the hierarchical group of that device.
Settings	Different setting items are displayed depending on the selected device (for the details on the individual device settings, refer to <b>Individual Device Settings</b> on page 85).

3. Select a hierarchical group for the added device.
  - If you select ACP in the device list, you can specify outdoor unit, ventilator, AHU, AWHP, ON/OFF, DI, or DO.
  - If you select outdoor unit in the device list, you can only add indoor units.
4. From the Toolbox, click **[Add]**.
5. Select the type of device to add.
  - The device types shown differ depending on the hierarchical group of the device.
6. Enter the device settings.
  - You may see different settings available depending on the device. For details, refer to **Individual Device Settings** on page 85.
7. To save these settings, click **[Apply]**.
8. To complete Add Device, click **[Transmit]**.

### Edit Device

You can change the settings of registered devices.

1. In the menu bar at the top, click **Set**.
2. From the Toolbox, click **[Device setting]**.
  - The device edit screen opens by default.
3. Select the device to edit from the list.
  - The edit device screen opens to show the device information.
4. Change the device settings in the edit device screen.
  - You may see different settings available depending on the device. For details, refer to **Individual Device Settings** on page 85.
5. To save these settings, click **[Apply]**.
6. To complete Edit Device, click **[Transmit]**.

### Delete Device

Follow these steps to delete a device from the list.

1. In the menu bar at the top, click **Set**.
2. From the Toolbox, click **[Device setting]**.
  - The device edit screen opens by default.
3. Select the device to delete from the list.
4. From the Toolbox, click **[Delete]**.
5. When you are prompted to confirm the deletion, click **[OK]**.
  - The selected device is deleted and removed from the list.
6. To complete Delete Device, click **[Transmit]**.

## Import ACP Settings

You can import ACP settings from previously registered device.

1. In the menu bar at the top, click **Set**.
2. From the Toolbox, click **[Device setting]**.
  - The device edit screen opens by default.
3. Select an ACP from the installation list, then click **[Import ACP setting]**.
  - The import settings window opens.
4. To overwrite the current settings with the imported settings, click **[OK]**.
  - The imported ACP settings are immediately applied.

## Adding ACP

Follow these steps to add an additional ACP.

1. In the menu bar at the top, click **Set**.
2. From the Toolbox, click **[Device setting]**, then click **[Add ACP]**.
3. Enter the settings of the new ACP in the edit device screen.

**Add device**

**Type**

Outdoor Unit   
  Ventilator   
  AWHP   
  AHU   
  Chiller   
  On/Off device   
  DI   
  DO

Indoor Unit

---

**Set**

ACP name

Address

IP  .  .  .

ACP model  ▼

Port 9200

Item	Description
ACP name	Give a name to the ACP for easy recognition.
Address	The software address of the ACP.
IP	The IP address of the ACP. (Use a static IP when using AC Manager Plus.)
ACP model	Click <b>[▼]</b> to select a ACP type (Standard / Premier / ACSmart Primium)
Port	The port number assigned to the ACP.

4. To save these settings, click **[Apply]**.

## Individual Device Settings

Individual Device Settings are as follows.

### ■ Outdoor Units

**Add device**

**Type**

Outdoor Unit  
  Ventilator  
  AWP  
  AHU  
  Chiller  
  On/Off device  
  DI  
  DO

Indoor Unit

---

**Set**

ACP name 00

Address

Name

Model

Capacity

Outdoor unit capacity control function  Support  Not applied

Add in batch

Item	Description
ACP name	The hierarchical ACP for the selected device.
Address	The software address of the device.
Name	<ul style="list-style-type: none"> <li>The name of the device shown in the system.</li> <li>When adding a batch of devices, use the <b>"Device type_Device address"</b> format for names.</li> </ul>
Model	The product model of the device.
Capacity	The product capacity of the device.
Whether PDI is installed	Indicate if PDI is installed.
Outdoor unit capacity control function	Indicate if the unit supports capacity control.
Add in batch	When this box is checked, the device will be added in a batch. (When adding in batch, address conflicts generate warnings)

## Indoor Units

**Add device**

**Type**

Outdoor Unit  
  Ventilator  
  AWHP  
  AHU  
  Chiller  
  On/Off device  
  DI  
  DO

Indoor Unit

---

**Set**

ACP name 00

Outdoor unit name ODU\_00

Address

Name

Model

Type  ▼

Capacity

Function to cancel filter alarm  Support  Not applied

Add in batch

Item	Description
ACP name	The hierarchical ACP for the selected device.
Outdoor unit name	The name of the connected outdoor unit.
Address	The software address of the device.
Name	<ul style="list-style-type: none"> <li>The name of the device shown in the system.</li> <li>When adding a batch of devices, use the "<b>Device type_Device address</b>" format for names.</li> </ul>
Model	The product model of the device.
Type	Select the type of indoor unit.
Capacity	The product capacity of the device.
Function to cancel filter alarm	Indicate if the filter alarm on the device can be disabled.
Add in batch	When this box is checked, the device will be added in a batch. (When adding in batch, address conflicts generate warnings)

## ■ Ventilator

**Add device**

**Type**

Outdoor Unit  
  **Ventilator**  
  AWHP  
  AHU  
  Chiller  
  On/Off device  
  DI  
  DO

Indoor Unit

---

**Set**

ACP name 00

Address

Name

Model

Type  ▼

Capacity

Add in batch

Item	Description
ACP name	The hierarchical ACP for the selected device.
Address	The software address of the device.
Name	<ul style="list-style-type: none"> <li>The name of the device shown in the system.</li> <li>When adding a batch of devices, use the "<b>Device type_Device address</b>" format for names.</li> </ul>
Model	The product model of the device.
Type	Select a ventilator type.
Capacity	The product capacity of the device.
Add in batch	When this box is checked, the device will be added in a batch. (When adding in batch, address conflicts generate warnings)

## ■ AWHP

**Add device**

**Type**

Outdoor Unit  
  Ventilator  
  AWHP  
  AHU  
  Chiller  
  On/Off device  
  DI  
  DO

Indoor Unit

---

**Set**

ACP name: 00

Address:

Name:

Model:

Type:

Capacity:

Temperature display:  Outlet water    Indoor

Add in batch

Item	Description
ACP name	The hierarchical ACP for the selected device.
Address	The software address of the device.
Name	<ul style="list-style-type: none"> <li>The name of the device shown in the system.</li> <li>When adding a batch of devices, use the "<b>Device type_Device address</b>" format for names.</li> </ul>
Model	The product model of the device.
Type	Select the AWHP type.
Capacity	The product capacity of the device.
Temperature display	Select which temperature measurement to display.
Add in batch	When this box is checked, the device will be added in a batch. (When adding in batch, address conflicts generate warnings)



## ■ AHU

**Add device**

**Type**

Outdoor Unit  
  Ventilator  
  AWHP  
  AHU  
  Chiller  
  On/Off device  
  DI  
  DO

Indoor Unit

---

**Set**

ACP name 00

Address

Name

Model

Basic mode  Cool  For Cooling/Heating

AHU type  General  Out-air unit (General)  EmptySystemSpecialDays  Compact (Single Fan)

Additional mode  None  Dry  Power save  Dry, power save

Additional function  None  Auto Ventilation  Humidifier  Auto ventilation, humidify

Add in batch

Item	Description
ACP name	The hierarchical ACP for the selected device.
Address	The software address of the device.
Name	<ul style="list-style-type: none"> <li>The name of the device shown in the system.</li> <li>When adding a batch of devices, use the "<b>Device type_Device address</b>" format for names.</li> </ul>
Model	The product model of the device.
Basic mode	Select between cooling or cooling/heating mode.
AHU type	Select the AHU type.
Additional modes	Select any additional operating modes the device supports.
Additional function	Select any additional features the device supports.
Add in batch	When this box is checked, the device will be added in a batch. (When adding in batch, address conflicts generate warnings)

## ■ Chiller

**Add device**

**Type**

Outdoor Unit  
  Ventilator  
  AWHP  
  AHU  
  Chiller  
  On/Off device  
  DI  
  DO

Indoor Unit

---

**Set**

ACP name 00

Address

Name

Type

Number of cycles

Running mode  Exclusively for cooling  For Cooling/Heating

Cooling type  Water-Cooled  Air-Cooled

Add in batch

Item	Description
ACP name	The hierarchical ACP for the selected device.
Address	The software address of the device.
Name	<ul style="list-style-type: none"> <li>The name of the device shown in the system.</li> <li>When adding a batch of devices, use the <b>"Device type_Device address"</b> format for names.</li> </ul>
Type	Select a chiller type.
Number of Cycles	Set the number of chiller cycle.
Running mode	Select either cooling or heating.
Cooling Type	Select either water-cooling or air-cooling.
Add in batch	When this box is checked, the device will be added in a batch. (When adding in batch, address conflicts generate warnings)

## ■ On/Off device

**Add device**

**Type**

Outdoor Unit   
  Ventilator   
  AWHP   
  AHU   
  Chiller   
  On/Off device   
  DI   
  DO

Indoor Unit

---

**Set**

ACP name 00

Address

Name

Add in batch

Item	Description
ACP name	The hierarchical ACP for the selected device.
Address	The software address of the device.
Name	<ul style="list-style-type: none"> <li>The name of the device shown in the system.</li> <li>When adding a batch of devices, use the "<b>Device type_Device address</b>" format for names.</li> </ul>
Add in batch	When this box is checked, the device will be added in a batch. (When adding in batch, address conflicts generate warnings)

## ■ DI/DO

**Add device**

**Type**

Outdoor Unit   
 Ventilator   
 AWHP   
 AHU   
 Chiller   
 On/Off device   
 DI   
 DO

Indoor Unit

---

**Set**

ACP name: 00

Name:

Port:

Add in batch

Item	Description
ACP name	The hierarchical ACP for the selected device.
Name	<ul style="list-style-type: none"> <li>The name of the device shown in the system.</li> <li>When adding a batch of devices, use the "<b>Device type_Device address</b>" format for names.</li> </ul>
Port	The port number assigned to the device.
Add in batch	When this box is checked, the device will be added in a batch. (When adding in batch, address conflicts generate warnings)

## Adding Groups

Follow these steps to add a new group.

1. In the menu bar at the top, click **Set**.
2. From the Toolbox, click **[Device setting]**, then click **[Edit group]**.
  - The edit group screen opens.

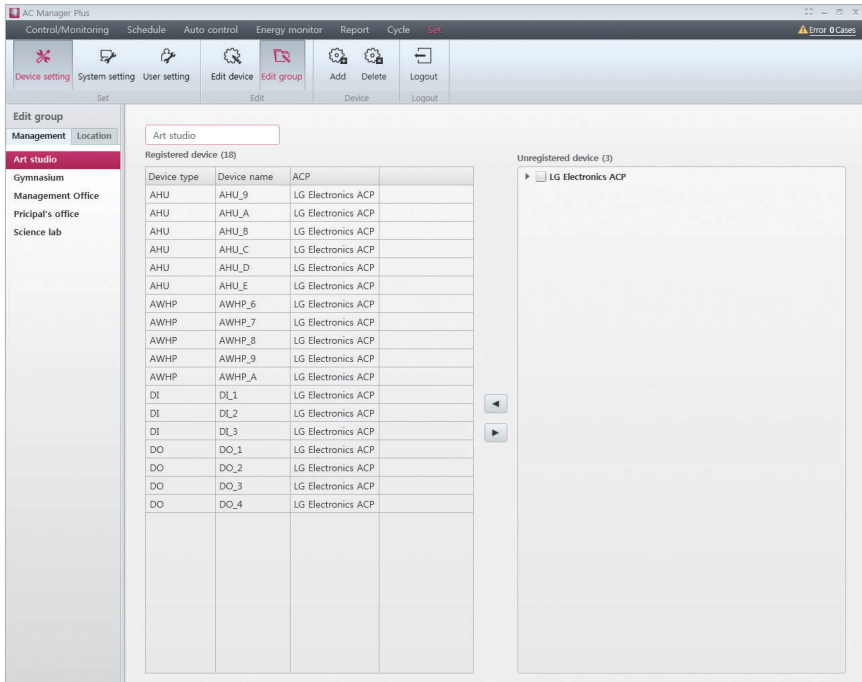

3. In the group list, click the appropriate tab (**Management, Location**).
4. Click **[Add]** button.
  - The add group screen opens.
5. If you selected the **Management** tab in step 3, you can add the group name.
6. If you selected the **Location** tab in step 3, you can type the building name, number of floors, and description.
7. To register a new device in the device list, check the box of the device you wish to add in the unregistered device list and click **[<]** button.
8. To save these settings, click **[Apply]**.

## Editing Groups

Follow these steps to change group settings.

1. In the menu bar at the top, click **Set**.
2. From the Toolbox, click **[Device setting]**, then click **[Edit group]**.
  - The edit group screen opens.

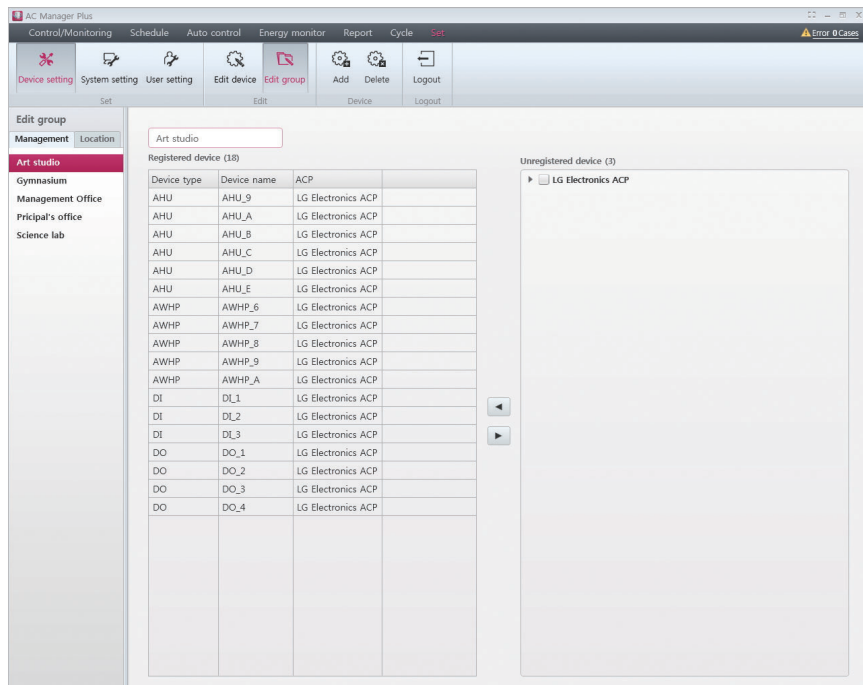

3. In the group list, click the appropriate tab (**Management**, **Location**).
4. Select a group.
5. If you selected the **Management** tab in step 3, you can modify the group name.
6. If you selected the **Location** tab in step 3, you can modify the building name, number of floors, and description.
7. To remove a device from the registered device list, select the device in the list and **[▶]**.
8. To register a new device in the device list, check the box of the device you wish to add in the unregistered device list and click **[◀]** button.
9. To save these settings, click **[Apply]**.

## Deleting Groups

Follow these steps to delete a group from the group list.

1. In the menu bar at the top, click **Set**.
2. From the Toolbox, click **[Device setting]**, then click **[Edit group]**.
  - The edit group screen opens.
3. Select the group to delete from the list and click **[Delete]** in the Toolbox.
4. When you are prompted to confirm the deletion, click **[OK]**.
  - The selected group is deleted and removed.

## System Setting

This section explains how to set the system environment of AC Manager Plus.

### Basic setting

Follow these steps to set or change the default system environment.

1. In the menu bar at the top, click **Set**.
2. From the Toolbox, click **[System setting]**.
3. In the system settings list, press **[Basic Setting]** button.
  - The default setting screen opens.
4. Set the control environment for AC Manager Plus as desired.

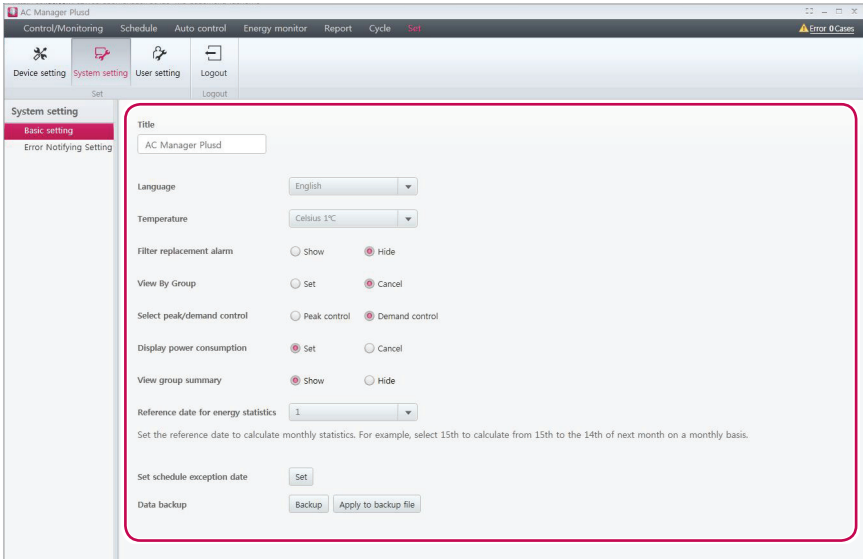

Item	Description
Title	Name the setting configuration for easy reference.
Language	Click <b>[▼]</b> to select a language (한국어/ English/ Español/ Português/ Italiano/ Turkish/ Deutsch/ Polski/ Русский/ Français).
Temperature	Click <b>[▼]</b> to select a control temperature unit type you want (Celsius 1°C / Celsius 0.5°C / Fahrenheit 1°F).
Filter replacement alarm	Choose to show or hide the filter replace alarm in the system.
View By Group	<p><b>Set / Cancel</b> the devices of the selected groups in Control/Monitoring</p> <ul style="list-style-type: none"> <li>• If you select to <b>Cancel</b>, the program may slow depending on the performance of the PC.</li> </ul>



Item	Description
Select peak / demand control	<ul style="list-style-type: none"> <li>• <b>Peak Control:</b> You can use peak control feature in the auto control menu.</li> <li>• <b>Demand Control:</b> You can use the demand control feature in the auto control menu.</li> </ul>
Display power consumption	Set or Cancel power consumption in the AC Manager Plus screen.
View group summary	You can show or hide the status of devices in groups in Control/Monitoring.
Reference date for energy statistics	<p>Click [▼] to select a date</p> <p>Select a reference date for monthly power consumption computations.</p> <p>Calculations are made across one calendar month starting from the selected date.</p>
Set schedule exception date	Manage schedule exception dates.
Data backup	<ul style="list-style-type: none"> <li>• <b>Backup:</b> Immediately backup data as a .csv file.</li> <li>• <b>Apply to backup file:</b> Set a file to regularly backup data. The file is overwritten with each backup.</li> </ul>

5. To save these settings, click **[Apply]**.



### CAUTION

- If ACP is connected to link with AC Manager Plus, do not use ACP to use Peak Control directly. ACP operates based on the peak operation rate settings of AC Manager Plus.
- If the target operation rate is controlled by AC Manager Plus, it should be that AC Manager Plus = Peak Control and ACP = Demand Control. If the target operation rate is controlled by Demand Controller, it should be that AC Manager Plus = Demand Control and ACP = Demand Control. If the target operation rate is controlled by ACP, it should be that AC Manager Plus = Demand Control and ACP = Peak Control.

## Setting Exceptions

Follow these steps to add or delete exception dates.

1. Navigate to **System setting > Basic setting [Setting]** to schedule exception dates.
  - The exception setting screen opens.
2. Delete or add exception dates as desired.

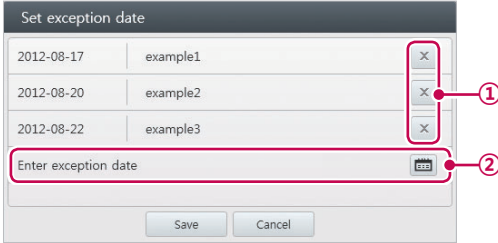

No.	Item	Description
①	Delete Selected	Delete the selected exception date.
②	Add Exception	<ul style="list-style-type: none"> <li>• Add an additional exception date.</li> <li>•  Select exception dates to add by clicking → Enter a name for the exception in the input box.</li> </ul>

3. To save these settings, click **[Save]**.

## Error Notifying Setting

You can set or change the error notification.

1. In the menu bar at the top, click **Set**.
2. From the Toolbox, click **[System setting]**.
3. In the system settings list, click **[Error Notifying Setting]** button.
  - Error Notification Settings screen is displayed.
4. Set the control environment for AC Manager Plus as desired.

The screenshot shows the 'Error Notifying Setting' dialog box within the AC Manager Plus interface. The dialog has a title bar with 'AC Manager Plus' and a status bar indicating 'Error 96 Cases'. The main content area includes the following settings:

- Error Popup:** Radio buttons for 'Set' and 'Cancel', with 'Cancel' selected.
- Error Notifying Mail Setting:** Radio buttons for 'Set' and 'Cancel', with 'Set' selected.
- Email Title:** Text input field containing 'test'.
- To (Email Address):** Text input field containing 'tst@lae.com'.
- Time interval sending error email (Minutes):** Dropdown menu set to '10 Minutes'.

Item	Description
Error Popup	Select to turn on (or off) a popup that shows a list of errored devices.
Error Notifying Mail Setting	Selects to send (or send not) the address and error code of an errored device by email.
Email Title	Select the email address.
To (Email Address)	Type the email address of the receiver.
Time interval sending error email (Minutes)	Select a send cycle for error occurrence (10 Minute / 20 Minute / 30 Minute / 40 Minute / 50 Minute / 60 Minute)

5. To save these settings, click **[Apply]**.

### Error Message Popop

An error occurs during using the program, the error popup message is displayed.

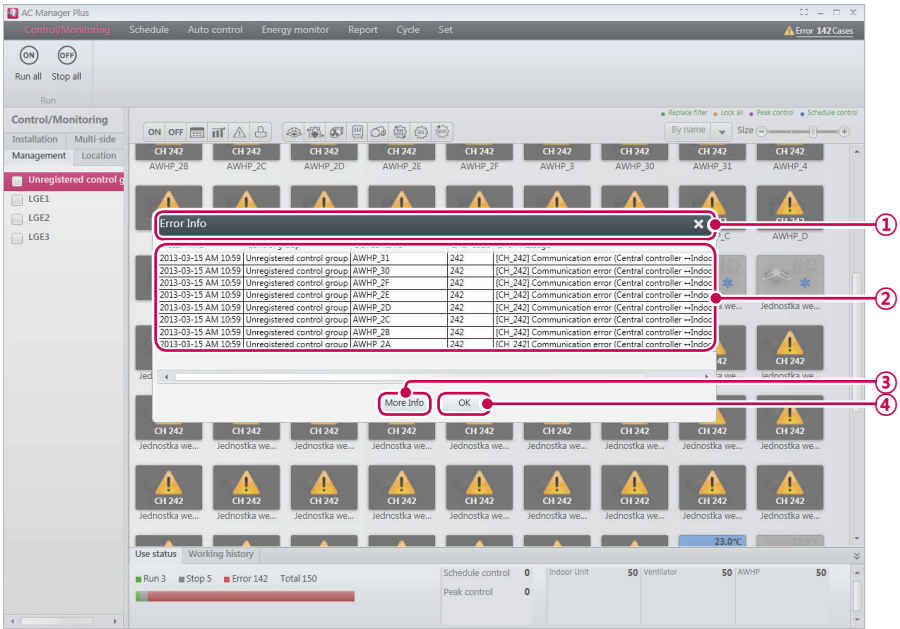

No.	Item	Description
①	Title display	Displays the error popup message
②	Information display	Provides information on the error - Displays up to 8 errors in the order of occurrence
③	[More Info]	<b>Report &gt; Working history &gt; Error</b> page to provide detailed information
④	[OK]	Closes the popup message

### NOTES

If you don't want to display error popup messages, go to **Setting > System Setting** and, in **Error Notifying Setting**, turn off Error Popop.

**Class B device****NOTES**

This equipment has been tested and found to comply with the limits for a Class B digital device, pursuant to part 15 of the FCC Rules.

These limits are designed to provide reasonable protection against harmful interference in a residential installation.

This equipment generates, uses and can radiate radio frequency energy and, if not installed and used in accordance with the instructions, may cause harmful interference to radio communications. However, there is no guarantee that interference will not occur in a particular installation. If this equipment does cause harmful interference to radio or television reception, which can be determined by turning the equipment off and on, the user is encouraged to try to correct the interference by one or more of the following measures:

- Reorient or relocate the receiving antenna.
- Increase the separation between the equipment and receiver.
- Connect the equipment into an outlet on a circuit different from that to which the receiver is connected.
- Consult the dealer or an experienced radio/TV technician for help.

**Caution**

Changes or modifications not expressly approved by the manufacturer responsible for compliance could void the user's authority to operate the equipment.

**Disposal of your old appliance**

1. When this crossed-out wheeled bin symbol is attached to a product it means the product is covered by the European Directive 2002/96/EC.
2. All electrical and electronic products should be disposed of separately from the municipal waste stream via designated collection facilities appointed by the government or the local authorities.
3. The correct disposal of your old appliance will help prevent potential negative consequences for the environment and human health.
4. For more detailed information about disposal of your old appliance, please contact your city office, waste disposal service or the shop where you purchased the product.

## User Settings

This section explains how to set AC Manager Plus users

### Administrator

Only the administrator account can change user environments.

1. In the menu bar at the top, click **Set**.
2. From the Toolbox, click **[User setting]**.
3. Click the **Administrator** user in the user list.
  - The setting screen for the administrator opens. Modify the user settings and system environment as desired.

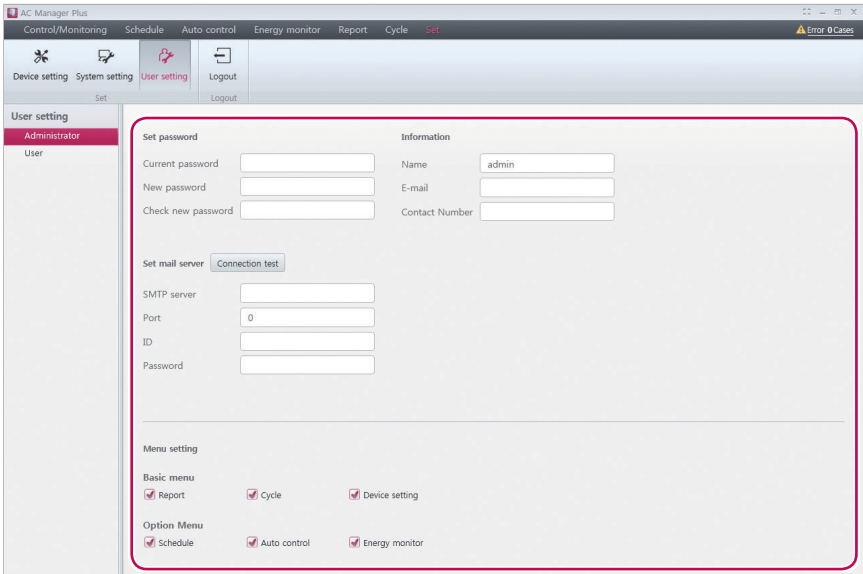

Item	Description
Set Password	<ul style="list-style-type: none"> <li>• Change the user's password if desired.                             <ul style="list-style-type: none"> <li>- <b>Current password</b>: Enter user's current password.</li> <li>- <b>New password</b>: Enter a new password.</li> <li>- <b>Check new password</b>: Enter the new password one more time.</li> </ul> </li> </ul>
Information	<ul style="list-style-type: none"> <li>• Modify the user's personal information.</li> <li>• <b>Name</b>: Enter the user's name.</li> <li>• <b>E-mail</b>: Enter the user's e-mail address.</li> <li>• <b>Contact Number</b>: Enter a phone number or a mobile number to contact this user.</li> </ul>

Item	Description
Set mail server	<ul style="list-style-type: none"><li>• Administrator E-mail Server Settings<ul style="list-style-type: none"><li>- <b>SMTP server:</b> Enter the address of the SMTP server.</li><li>- <b>Port:</b> Enter the port number of the server.</li><li>- <b>ID:</b> Enter the user's ID for the e-mail server.</li><li>- <b>Password:</b> Enter the user's password for the e-mail server.</li><li>- <b>Connection test:</b> Performs a test to connect to the user's e-mail account (you must be connected to internet).</li></ul></li></ul>
Menu setting	<ul style="list-style-type: none"><li>• Check the boxes to customize the administrator's menu (you may select multiple items).<ul style="list-style-type: none"><li>- <b>Basic menu:</b> Report, Cycle, Device Settings</li><li>- <b>Option Menu:</b> Schedule, Auto Control, Energy Monitor</li></ul></li></ul>

4. To save these settings, click **[Apply]**.

**User**

Only an account with administrator privileges can modify a general user's environment.

1. In the menu bar at the top, click **Set**.
2. From the Toolbox, click **[User setting]**.
3. Click the **User** in the user list.
  - The setting screen for the general user opens. You can add, modify, and delete users from this screen.

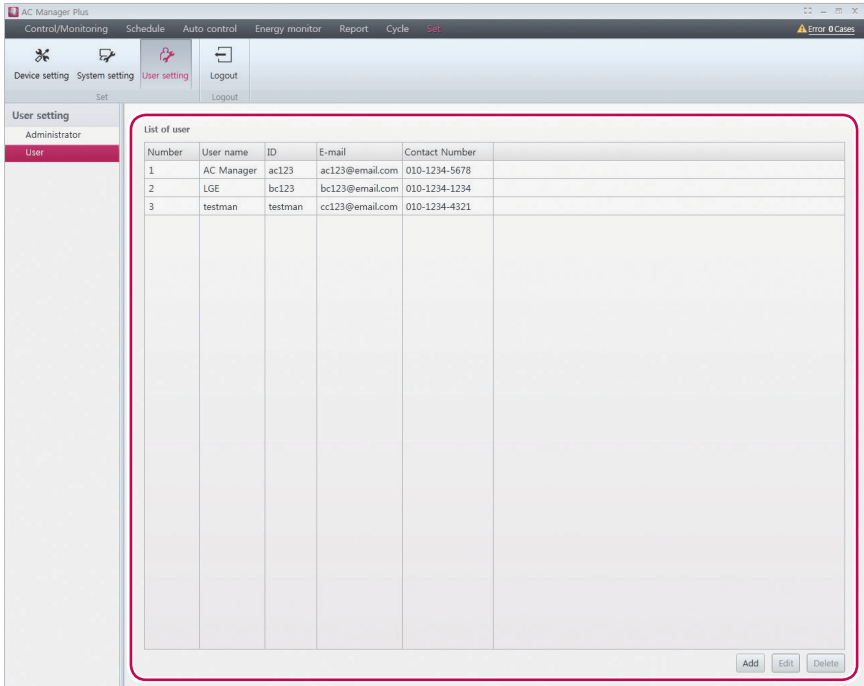

Item	Description
List of user	A brief summary of all general users. <ul style="list-style-type: none"> <li>• Number, User Name, ID, E-mail, Contact</li> <li>• <b>[Add]</b> Button: Add a new user.</li> <li>• <b>[Edit]</b> Button: Edit the selected user.</li> <li>• <b>[Delete]</b> Button: Delete the selected user.</li> </ul>



Item	Description
Add & Edit	<p>Adding or editing a general user.</p> <ul style="list-style-type: none"><li>• <b>Name:</b> Enter the user's name.</li><li>• <b>ID:</b> User IDs are case sensitive. Use both upper and lower case letters.</li><li>• <b>Password:</b> Use numbers and upper and lower case letters for maximum security.</li><li>• <b>E-mail:</b> Enter an e-mail address for the user.</li><li>• <b>Contact:</b> Enter a phone number or a mobile number to contact this user.</li></ul> <p>Menu Settings for General Users</p> <ul style="list-style-type: none"><li>• <b>Basic menu:</b> Report</li><li>• <b>Option Menu:</b> Schedule, Auto Control, Energy Monitor</li></ul>

4. To save these settings, click **[Apply]**.

## Information Management

A general user can view and modify his or her user information after logging in.

1. In the menu bar at the top, click **Set**.
2. From the Toolbox, click **[User setting]**.
3. Click **Information management** in the System Settings menu.
  - The info management screen opens. You can view and change user information in this screen.

The screenshot shows the AC Manager Plus application window. The top menu bar includes 'Control/Monitoring', 'Schedule', 'Peak control', 'Energy monitor', 'Report', and 'Set'. The 'Set' button is highlighted. Below the menu bar is a toolbox with 'System setting' and 'User setting' buttons. The 'User setting' button is selected. The main area displays the 'User setting' dialog box, which is titled 'Apply setting?'. Inside this dialog, there is a sub-dialog titled 'Manage personal information' with the following fields:

- Name: AC Manager Plus user1
- ID: ACManager
- Password: [masked with dots]
- Check password: [masked with dots]
- E-mail: AC123@email.com
- Contact Number: 01012345678

The 'Apply' and 'Cancel' buttons are visible at the bottom right of the dialog box.

Item	Description
Name	The user's name.
ID	The user's ID.
Password	To change the user's password, enter a new one here.
Check password	Enter the same password again to confirm.
E-mail	Enter an e-mail address for the user.
Contact Number	Enter a phone number or a mobile number to contact this user.

4. To save these settings, click **[Apply]**.

# Hint

Provide additional information required to use AC Manager Plus.

## AC Manager Plus Complete System Diagram

### Connecting AC Manager Plus to an ACP

Connecting an ACP to AC Manager Plus without a hub

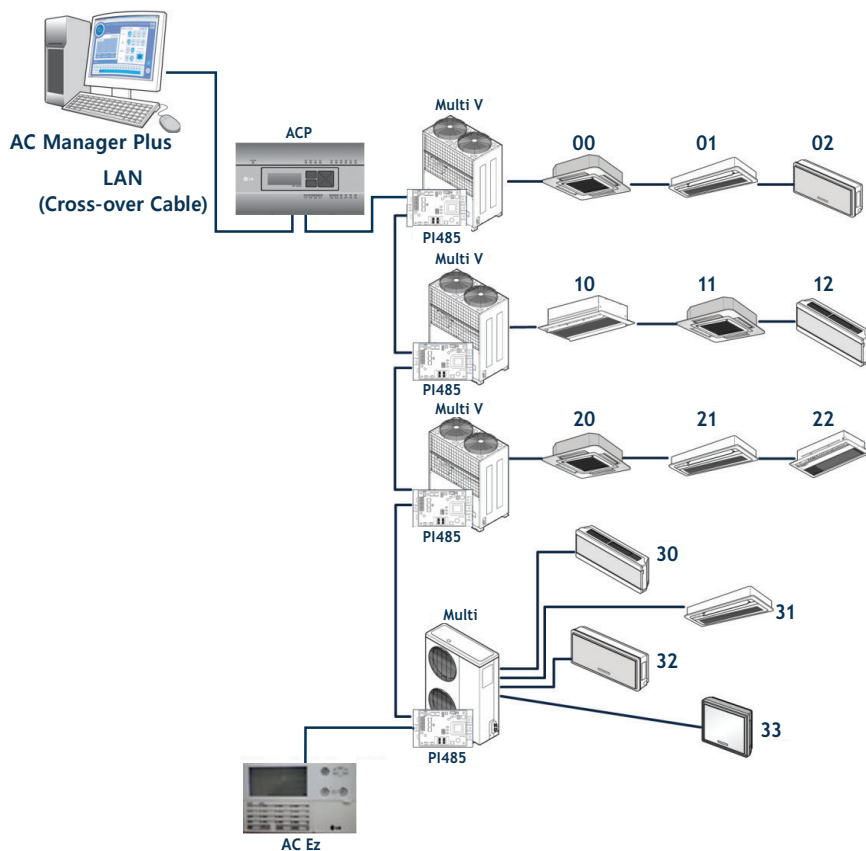

### NOTES

The allocated number to the indoor device is a sample address for central control, which is set to the indoor device.

Using a hub to connect AC Manager Plus to ACP

ENGLISH

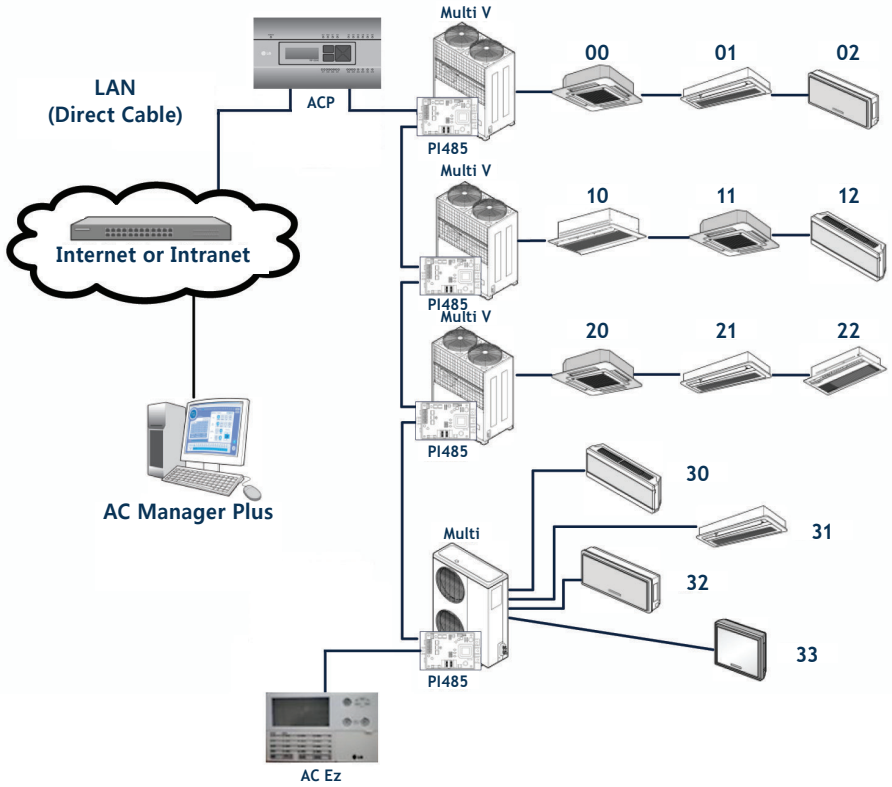

NOTES

AC Ez can be connected separately if required.

### Connecting AC Manager Plusto multiple ACPs

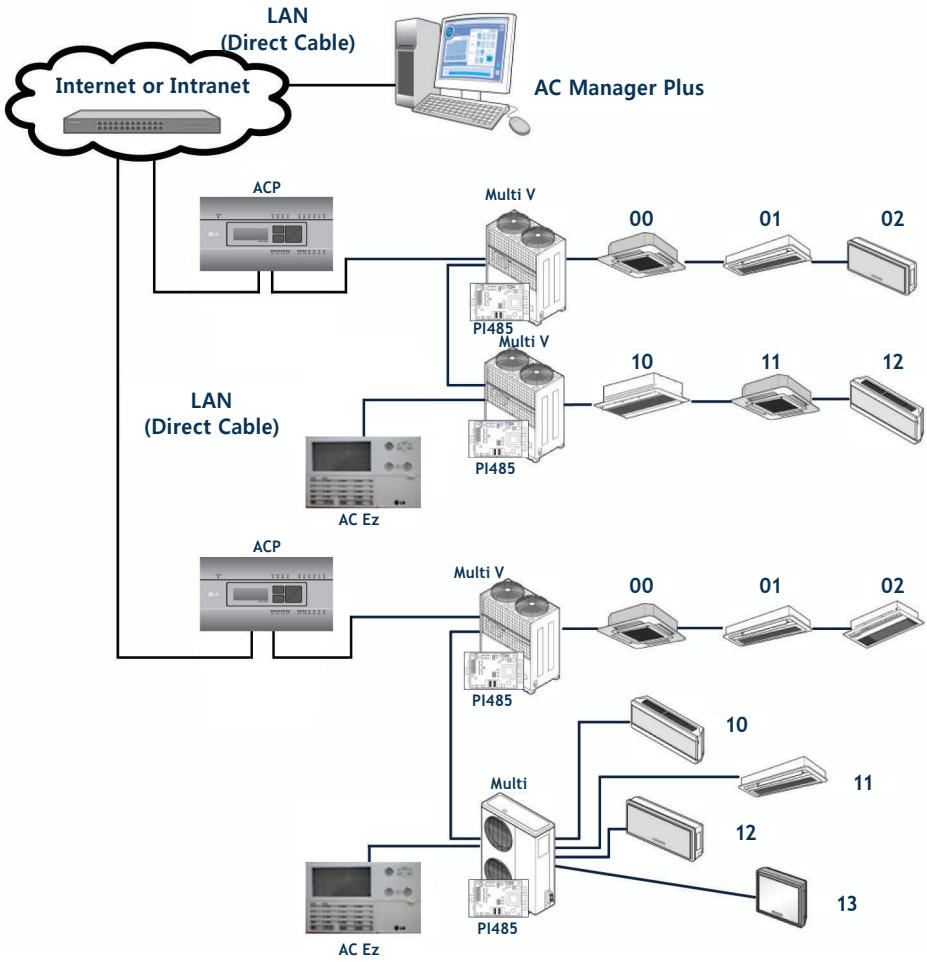

## Error Codes

The followings are the error codes that occur while using AC Manager Plus.

### Indoor Device, Ventilator or Direct Expansion Ventilator, AWHP / Hydro kit, AHU error

Error Code	Indoor Device	Ventilator or Direct Expansion Ventilator	AWHP / Hydro kit	AHU
0	No error	No error	No error	
1	Indoor sensor air) open/short	Air intake sensor malfunction	Indoor air thermometer malfunction	
2	Indoor sensor (intake pipe) open/short	Refrigerant intake thermometer malfunction	Refrigerant intake thermometer malfunction	Communication PCB indoor sensor (intake pipe) error
3	Remote control malfunction	Remote control malfunction	Remote control malfunction	The remote control is not functioning for 3 minutes or longer.
4	Drain pump malfunction	Drain pump malfunction		Communication PCB is not functioning for 3 minutes or longer.
5	Communication error (indoor ↔ outdoor)	Communication error (indoor ↔ outdoor)	Communication error (indoor ↔ outdoor)	Communication error (communication PCB ↔ outdoor)
6	Indoor sensor (outtake pipe) open/short	Refrigerant outtake thermometer malfunction	Refrigerant outtake thermometer malfunction	Communication PCB indoor sensor (outtake pipe) error
7	Atypical operation	Atypical operation	Atypical operation	
8			Hot water thermometer malfunction	Operate smoke control through smoke detection.
9	EEPROM ERROR (indoor unit)	EEPROM ERROR (indoor unit)	EEPROM ERROR (indoor unit)	
10	Indoor fan LOCK (operation error)	Indoor fan Lock (operation error)		
11			HHU/boiler communication error (HHU)	

<b>Error Code</b>	<b>Indoor Device</b>	<b>Ventilator or Direct Expansion Ventilator</b>	<b>AWHP / Hydro kit</b>	<b>AHU</b>
12	Indoor mid-pipe sensor error		Boiler error (HHU)	
13	Heater terminal block sensor (A-PAC)		Solar heat temperature sensor error	Temperature (ventilator, air supply, external air, Mix) is outside acceptable range.
14			Indoor unit flow switch operation error	Humidity (ventilator, air supply, external air) is outside acceptable range
15	O-ROTOR (BLDC FAN driver) communication error		Water pipe overheating	CO <sub>2</sub> value is within acceptable range
16			Simultaneous AWHP temperature sensor error	Pressure (pressure change, static pressure) is outside acceptable range
17		Direct expansion ventilator air out sensor	Inlet water temperature sensor error	Speed (ventilator and air supply flow) is outside acceptable range.
18		Direct expansion ventilator air return sensor	Outlet water temperature sensor error	
19		Direct Expansion Ventilator Main PCB ← Sub PCB communication error	Elec/Heater outlet water temperature sensor error	
20		Direct Expansion Ventilator Main PCB → Sub PCB communication error	Elec/heater error	

## Outdoor Unit Errors

Error Code	Description
21	DC peak
22	Max ct (CT 2): Maximum current error
23	DC link voltage (low)
24	High voltage/heat plate SW
25	Under-voltage/over-voltage
26	DC comp position error
27	PSC fault error
28	DC link voltage (high)
29	Comp over-current
30	Surge in static speed #2 compressor discharge temperature
31	CT err (low current)
32	Inverter discharge temperature error (high)
33	Surge in static speed #1 compressor discharge temperature
34	Surge in high voltage
35	Drop in low voltage
36	Low compression ratio error
37	Compression ratio limit exceeded
39	Communication error (inverter ↔ PFC)
40	Inverter CT sensor open/short
41	Inverter discharge temperature sensor open/short
42	Low voltage sensor open/short
43	Heat exchanger temperature sensor (top)
44	Outdoor air temperature sensor open/short
45	Outdoor pipe (top) sensor open/short
46	Compressor suction temperature sensor open/short
47	Static speed #1 compressor discharge temperature sensor error
48	Heat exchanger temperature sensor (bottom) (SUPER3: Static speed #2 compressor discharge temperature sensor error)
49	Outdoor voltage sensor error (SUPER3: IPM temperature sensor error)
50	Missing phase of outdoor 3-phase power
51	Over-capacity error (indoor unit capacity limit exceeded)
52	Communication error (inverter board → main board)
53	Communication error (indoor device → outdoor unit)
54	RST reverse phase detection



Error Code	Description
55	Communication error (central to main controller)
56	Communication error (main to central controller)
57	Communication error (main board to inverter board)
58	Incorrect connection of tax product (tax-exempt indoor unit to taxed outdoor unit)
59	Mixed installation of slave outdoor unit
60	PCB EEPROM error (MULTI V: inverter PCB EEPROM error)
61	Inverter discharge temperature error (high)
62	Heatsink error (high)
63	Outdoor pipe temperature error (low)
65	Heatsink Th error (open/short)
66	Bad connection/piping (incorrect connection of wire, pipe, LEV, etc.)
67	Outdoor fan lock error (with BLDC)
68	Static speed comp CT open (add MPS)
69	Static #1 CT sensor error
70	Static #2 CT sensor error
71	Input CT sensor error
72	Communication error (louver ↔ fan)
73	Input instant over-current (peak)
74	Inverter PCB phase unbalance
75	Fan CT sensor error
76	Fan DC link over-voltage error
77	Fan over-current error
78	Fan hall sensor error
79	Fan start failure error
80	Louver motor over-current
81	Louver limit SW error
82	A-cycle low pressure error
83	B-cycle low pressure error
84	A-cycle high pressure error
85	B-cycle high pressure error
86	Main PCB EEPROM error
87	Fan PCB EEPROM error
88	PFC PCB EEPROM error
89	Detachable type distributor communication error

## MultiV 20Hp, 30Hp, 40Hp, error

Error Code	Description
100	SLAVE1 static speed compressor 1 discharge temperature surge error
101	SLAVE1 static speed compressor 2 discharge temperature surge error
102	SLAVE2 static speed compressor 1 discharge temperature surge error
103	SLAVE2 static speed compressor 2 discharge temperature surge error
104	Communication error with outdoor unit (slave to master)
105	Fan board communication error (fan to outdoor unit)
106	Fan board (IPM fault)
107	Fan board (low voltage error)
108	Communication error (outdoor unit to fan)
109	SLAVE1 (high voltage SW error)
110	SLAVE1 (reverse phase error)
111	SLAVE1 (communication error: master to slave)
112	Master outdoor unit sensor (oil pipe temperature sensor error)
113	Master outdoor unit sensor (fluid pipe temperature sensor error)
114	Master outdoor unit sensor (overcooling inlet temperature sensor error)
115	Master outdoor unit sensor (overcooling outlet temperature sensor error)
116	SLAVE1 outdoor unit sensor (high voltage sensor error)
117	SLAVE1 outdoor unit sensor (low voltage sensor error)
118	SLAVE1 outdoor unit sensor (low voltage sensor error)
119	SLAVE1 outdoor unit sensor (oil pipe temperature sensor error)
120	SLAVE1 outdoor unit sensor (suction temperature sensor error)
121	SLAVE1 outdoor unit sensor (static speed compressor 1 discharge temperature error)
122	SLAVE1 outdoor unit sensor (static speed compressor 2 discharge temperature error)
123	SLAVE1 outdoor unit sensor (heat exchanger temperature sensor A error)
124	SLAVE1 outdoor unit sensor (heat exchanger temperature sensor B error)
125	SLAVE1 outdoor unit (fluid pipe temperature sensor error)
126	SLAVE1 outdoor unit (overcooling inlet temperature sensor error)
127	SLAVE1 outdoor unit (overcooling outlet temperature sensor error)
128	SLAVE2 outdoor unit sensor (high voltage sensor error)
129	SLAVE2 outdoor unit sensor (low voltage sensor error)
130	SLAVE2 outdoor unit sensor (air temperature sensor error)
131	SLAVE2 outdoor unit sensor (oil pipe temperature sensor error)
132	SLAVE2 outdoor unit sensor (suction temperature sensor error)

<b>Error Code</b>	<b>Description</b>
133	SLAVE2 outdoor unit sensor (static speed compressor 1 discharge temperature error)
134	SLAVE2 outdoor unit sensor (static speed compressor 2 discharge temperature error)
135	SLAVE2 outdoor unit sensor (heat exchanger temperature sensor A error)
136	SLAVE2 outdoor unit sensor (heat exchanger temperature sensor B error)
137	SLAVE2 outdoor unit (fluid pipe temperature sensor error)
138	SLAVE2 outdoor unit (overcooling inlet temperature sensor error)
139	SLAVE2 outdoor unit (overcooling outlet temperature sensor error)
140	Fluid pipe sensor error of heat recovery unit
141	Overcooling inlet sensor error of heat recovery unit
142	Overcooling outlet sensor error of heat recovery unit
143	Heat recovery unit communication error
144	Heat recovery unit reserve 1
145	Heat recovery unit reserve 2
146	Heat recovery unit reserve 3
147	Heat recovery unit reserve 4
148	Heat recovery unit reserve 5
176	SLAVE2 static speed 1 compressor over-current/under-current
177	SLAVE2 static speed 2 compressor over-current/under-current
178	SLAVE3 static speed 1 compressor over-current/under-current
179	SLAVE3 static speed 2 compressor over-current/under-current
180	Anti-Freeze (water-cooling)
181	Water temperature sensor error (water-cooling)
182	Sub Micom communication error
183	Oil supply failure
184	Inverter oil pipe temperature sensor error
185	Static #1 oil pipe temperature sensor error
186	Static #2 oil pipe temperature sensor error
193	Fan board heat plate temperature surge
194	Fan board heat plate temperature sensor error

## Super Errors

Error Code	Description
200	Fan board heat plate temperature sensor error
201	Fluid pipe sensor error (fluid pipe sensor of HR Unit1 open/short)
202	Overcooling inlet sensor error (overcooling inlet sensor of HR Unit1 open/short)
203	Overcooling outlet sensor error (overcooling outlet sensor of HR unit1 open/short)
204	Overcooling outlet sensor error (overcooling outlet sensor of HR unit1 open/short)
205	Fluid pipe sensor error (fluid pipe sensor of HR Unit2 open/short)
206	Overcooling inlet sensor error (overcooling inlet sensor of HR Unit2 open/short)
207	Overcooling outlet sensor error (overcooling outlet sensor of HR unit2 open/short)
208	Communication error (no outdoor unit signal for 3 min from HR unit2)
209	Fluid pipe sensor error (fluid pipe sensor of HR Unit3 open/short)
210	Overcooling inlet sensor error (overcooling inlet sensor of HR Unit3 open/short)
211	Overcooling outlet sensor error (overcooling outlet sensor of HR unit3 open/short)
212	Communication error (no outdoor unit signal for 3 min from HR unit3)
213	Fluid pipe sensor error (fluid pipe sensor of HR Unit4 open/short)
214	Overcooling inlet sensor error (overcooling inlet sensor of HR Unit4 open/short)
215	Overcooling outlet sensor error (overcooling outlet sensor of HR unit4 open/short)
216	Communication error (no outdoor unit signal for 3 min from HR unit4)
217	Fluid pipe sensor error (fluid pipe sensor of HR Unit5 open/short)
218	Overcooling inlet sensor error (overcooling inlet sensor of HR Unit5 open/short)
219	Overcooling outlet sensor error (overcooling outlet sensor of HR unit5 open/short)
220	Communication error (no outdoor unit signal for 3 min from HR unit5)
221	Fluid pipe sensor error (fluid pipe sensor of HR Unit6 open/short)
222	Overcooling inlet sensor error (overcooling inlet sensor of HR Unit6 open/short)
223	Overcooling outlet sensor error (overcooling outlet sensor of HR unit6 open/short)
224	Communication error (no outdoor unit signal for 3 min from HR unit6)
225	Fluid pipe sensor error (fluid pipe sensor of HR Unit7 open/short)
226	Overcooling inlet sensor error (overcooling inlet sensor of HR Unit7 open/short)
227	Overcooling outlet sensor error (overcooling outlet sensor of HR unit7 open/short)
228	Communication error (no outdoor unit signal for 3 min from HR unit7)
229	Fluid pipe sensor error (fluid pipe sensor of HR Unit8 open/short)
230	Overcooling inlet sensor error (overcooling inlet sensor of HR Unit 8 open/short)
231	Overcooling outlet sensor error (overcooling outlet sensor of HR unit8 open/short)
232	Communication error (no outdoor unit signal for 3 min from HR unit8)

Error Code	Description
233	Fluid pipe sensor error (fluid pipe sensor of HR Unit9 open/short)
234	Overcooling inlet sensor error (overcooling inlet sensor of HR Unit9 open/short)
235	Overcooling outlet sensor error (overcooling outlet sensor of HR unit9 open/short)
236	Communication error (no outdoor unit signal for 3 min from HR unit9)

## Central Controller Errors

Error Code	Description
240	Communication error (PC central controller ↔ I-GW)
242	Communication error (central controller ↔ indoor unit)
246	Data in time out error from central controller
247	Communication error (ACM Client ↔ ACM Server)
248	Communication error (ACP Client ↔ ACP Server)
250	Checksum error
251	Communication error (AC Smart to 128-room expansion kit)

## Chiller Errors

Error Code	Description
1	Common Air Sensor Error
2	Load Pipe In Sensor Error
3	HMI Communication Error
5	Outdoor Communication Error
6	Load Pipe Out Sensor Error
9	Remote Communication Error
11	Load Pump Interlock Error
13	Load Flow Switch Error
15	Remote Alarm Error
21	Inverter Compressor IPM Fault
22	Inverter Compressor Input Overcurrent (RMS)
23	Inverter Compressor DC Link Low Voltage
24	ODU High Pressure Switch Operation

<b>Error Code</b>	<b>Description</b>
25	High/Low Input Voltage
26	Inverter Compressor Start Failure Error
27	PSC/PFC Fault Error
28	Inverter DC Link High Voltage Error
29	Inverter Compressor Overcurrent
30	Constant-speed No.2 Compressor Discharge Temperature Increasing Excessively
32	Inverter Compressor Discharge Temperature Increasing Excessively
33	Constant-speed No.1 Compressor Discharge Temperature Increasing Excessively
34	High Pressure Increasing Excessively
35	Low Pressure Decreasing Excessively
36	Low Compression Ratio Error
39	Communication Error between the PFC Circuit and Inverter board
40	Inverter Compressor CT Sensor Failure
41	Inverter Compressor Discharge Temperature Sensor Failure
42	Low Pressure Sensor Failure
43	High Pressure Sensor Failure
44	ODU Air Temperature Sensor Failure
45	Heat Exchanger Temperature Sensor Failure
46	Inlet Temperature Sensor Failure
47	Constant-speed No.1 Compressor Discharge Temperature Sensor Failure
48	Constant-speed No.2 Compressor Discharge Temperature Sensor Failure
49	IPM Temperature Sensor Failure
50	Phase Loss of ODU 3-phase Power
52	Communication Failure with the Inverter Controls
53	Communication Failure between the IDU and ODU
54	Reverse Phase of the ODU 3-Phase Power
57	Communication Failure with the Inverter Controls
59	ODU Installation Failure
60	Inverter PCB EEPROM Error
67	Fan Lock
69	Constant-speed No.1 CT Sensor Error
70	Constant-speed No.2 CT Sensor Error
71	PFC CT Sensor Error
73	Inverter Compressor PCB Instantaneous Overcurrent (Peak)

Error Code	Description
74	Inverter Phase Unbalance
75	Fan CT Sensor Error
76	Fan DC Link High Voltage Error
77	Fan Overvoltage Error
78	Fan Hall Sensor Error
79	Fan Start Failure Error
86	Main PCB EEPROM Error
87	Fan PCB EEPROM Error
88	PFC PCB EEPROM Error
104	Communication Error between ODUs
105	Fan Board Communication Error
106	Fan PCB IPM Fault
107	Fan DC Link Low Voltage Error
113	Liquid Pipe Temperature Sensor Error
115	Super-cooling Exit Temperature Sensor Error
151	4-way Valve Switch Failure
153	Left Heat Exchanger Temperature Sensor Error
154	Right Heat Exchanger Temperature Sensor Error
173	Constant-speed No.1 Overcurrent/Undercurrent
174	Constant-speed No.2 Overcurrent/Undercurrent
180	Plate Type Heat Exchanger Freezing & Bursting Error
182	Sub Micom Communication Error
188	Load-side Water Temperature Sensor Failure
190	Inverter Board Heat Sink Temperature Increasing Excessively
191	Inverter Board Heat Sink Temperature Sensor Failure
193	Fan Board Heat Sink Temperature Increasing Excessively
194	Fan Board Heat Sink Temperature Sensor Failure

## Pre-Tech Support Checklist

If the product malfunctions, please check the following before calling the service center.

Symptom	Check	Actions
I can't connect with the server.	<ul style="list-style-type: none"> <li>Is your computer connected to the internet?</li> <li>Is the server information entered correctly?</li> </ul>	<ul style="list-style-type: none"> <li>Check your internet connection.</li> <li>Verify the IP address of the server.(If you are directly using the server, enter its IP address as 127.0.0.1.)</li> </ul>
I can't log in.	Did you type in the correct password?	Make sure Caps Lock is not on and try again.
The program can't find the authentication key.	<ul style="list-style-type: none"> <li>Is the authentication key correctly connected?</li> <li>Is the authentication key connected to a USB hub?</li> </ul>	<ul style="list-style-type: none"> <li>Remove and reconnect the authentication key.</li> <li>The authentication key may not function when connected to a USB hub due to a lack of power. Connect the authentication key directly to the PC.</li> </ul>
The device icon has the error mark.	Is your ACP operating normally?	Restart your ACP.



---

 **MEMO**

---

 MEMO

---

 MEMO

---

 MEMO

---

 **MEMO**

---

 MEMO



