



LG
Life's Good

OWNER'S MANUAL

MONITOR SIGNAGE

Please read this manual carefully before operating the your set and retain it for future reference.

MONITOR SIGNAGE MODELS
29WR30MR

CONTENTS

3 LICENSES

4 ASSEMBLING AND PREPARING

- 4 Accessories
- 5 Parts and buttons
- 6 STORAGE METHOD FOR PANEL PROTECTION
- 6 - Correct Method
- 6 - Incorrect Method
- 7 Using the IR Receiver
- 8 Mounting on a wall

9 REMOTE CONTROL

11 USING THE MONITOR

- 11 Connecting to a PC
- 12 - DVI connection
- 12 - Display Port connection
- 13 - HDMI connection
- 13 - IR Receiver connection
- 14 - LAN connection
- 15 Daisy Chain Monitors
- 15 - DP Cable
- 16 Using additional options
- 16 - Adjusting aspect ratio

17 ENTERTAINMENT

- 17 - Connecting to a wired network

19 CUSTOMIZING SETTINGS

- 19 Menu Settings
- 20 - Ratio Settings
- 21 - Func. Settings
- 22 - PIP settings
- 24 - Picture

- 25 - Color
- 26 - Settings
- 28 - Time
- 29 - Network

30 TROUBLESHOOTING

32 SPECIFICATIONS

35 CONTROLLING THE MULTIPLE PRODUCT

- 35 Connecting the cable
- 35 RS-232C Configurations
- 35 Communication Parameter
- 36 Command Reference List
- 37 Transmission / Receiving Protocol

LICENSES

Supported licenses may differ by model. For more information of the licenses, visit www.lg.com.



The terms HDMI and HDMI High-Definition Multimedia Interface, and the HDMI logo are trademarks or registered trademarks of HDMI Licensing LLC in the United States and other countries.

ASSEMBLING AND PREPARING

Accessories

Check your product box for the following items. If there are any missing accessories, contact the local dealer where you purchased your product. The illustrations in this manual may differ from the actual product and accessories.

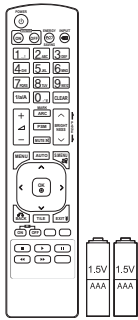

Remote control and Batteries

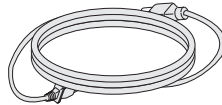

Power Cord

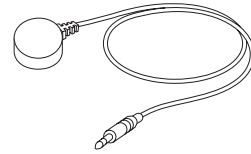

IR Receiver



**CD(Owner's Manual,
SuperSign Program/Owner's
Manual)/ Card**

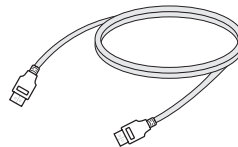

HDMI Cable



CAUTION

- Do not use any unapproved or counterfeit parts or accessories to ensure the safety and product life span.
- Any damages or injuries by using pirated items are not covered by the warranty.



NOTE

- The accessories supplied with your product may vary depending on the model.
- Product specifications or contents in this manual may be changed without prior notice due to upgrade of product functions.

Parts and buttons

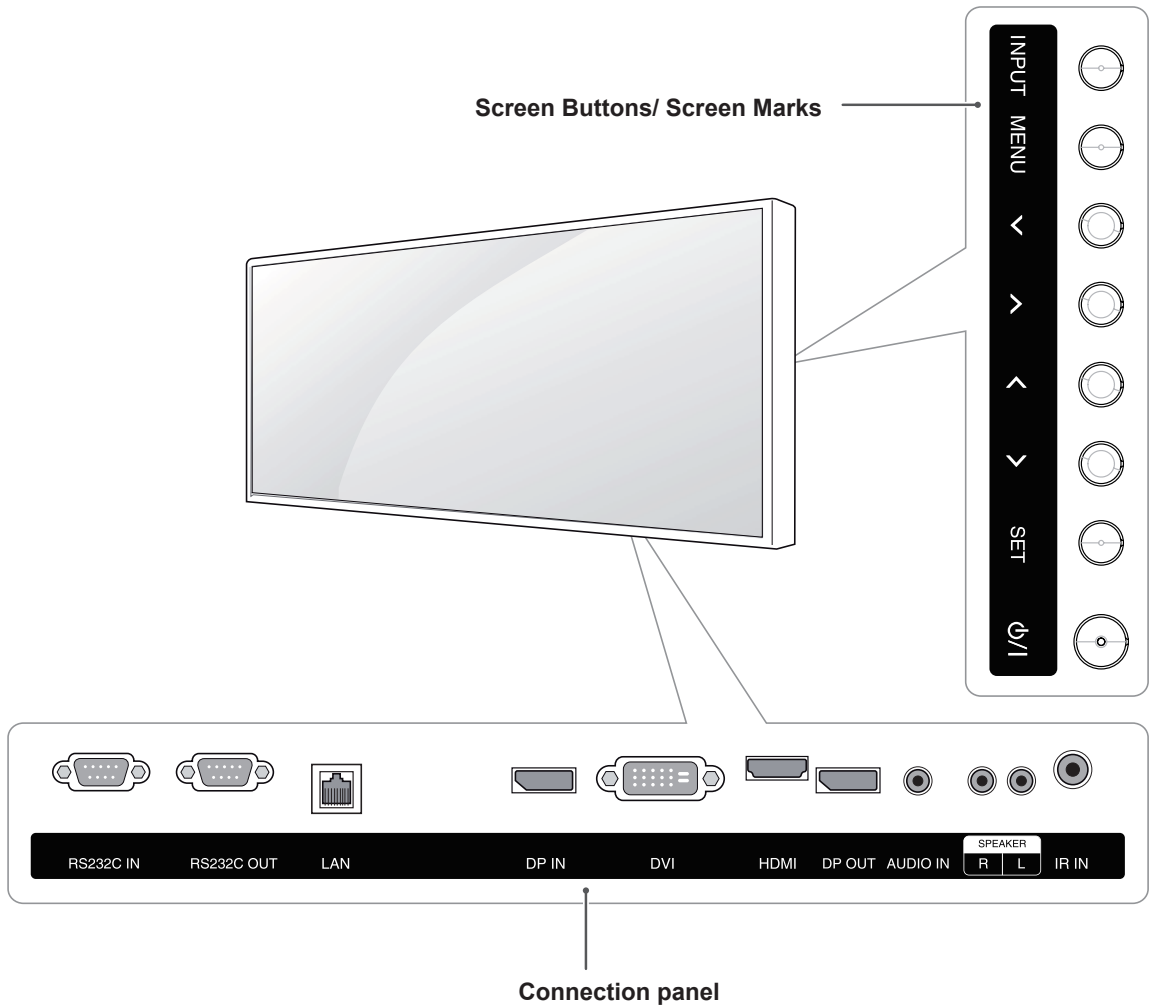

Screen Marks	Description
INPUT	Changes the input source.
MENU	Accesses the main menus, or saves your input and exits the menus.
^ V	Adjust the up and down.
< >	Adjusts the volume level.
AUTO/SET	Displays the current signal and mode.
⏻ / I	Turns the power on or off.

STORAGE METHOD FOR PANEL PROTECTION

Correct Method

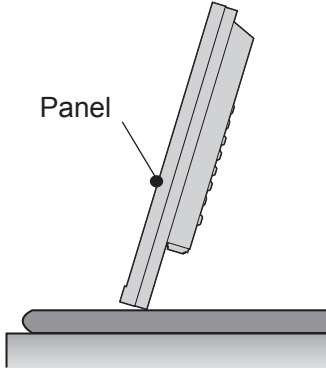

If the product needs to be set upright, hold both sides of the product, and tilt backward carefully for. Do not let the panel touch the floor.

Incorrect Method

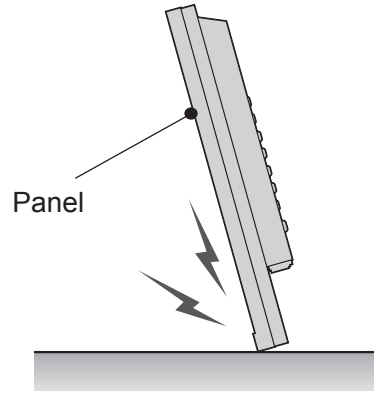

If the product is tilted onto the bezel, the bottom of the panel may be damaged.

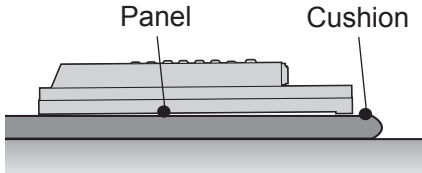

When laying down the product, lay a cushion on a flat floor. Put the product on it with the panel of the product facing down.

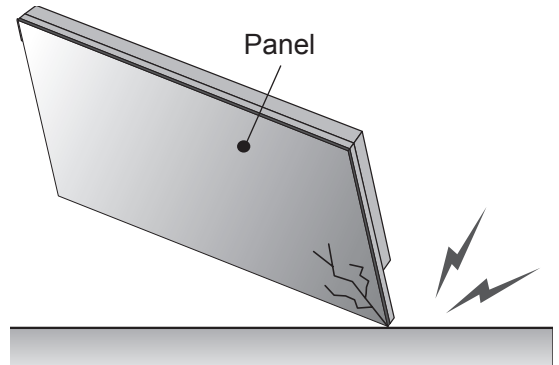

If the product is tilted onto the edge of the panel, the panel may be damaged.

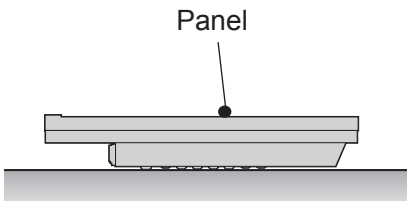

If there is not a cushion available, ensure the floor is clean and then lay the product down carefully with the panel facing either upward or downward. At this time, be careful for objects not to fall on the panel.

Using the IR Receiver

This allows a remote control sensor to be placed in a custom location.

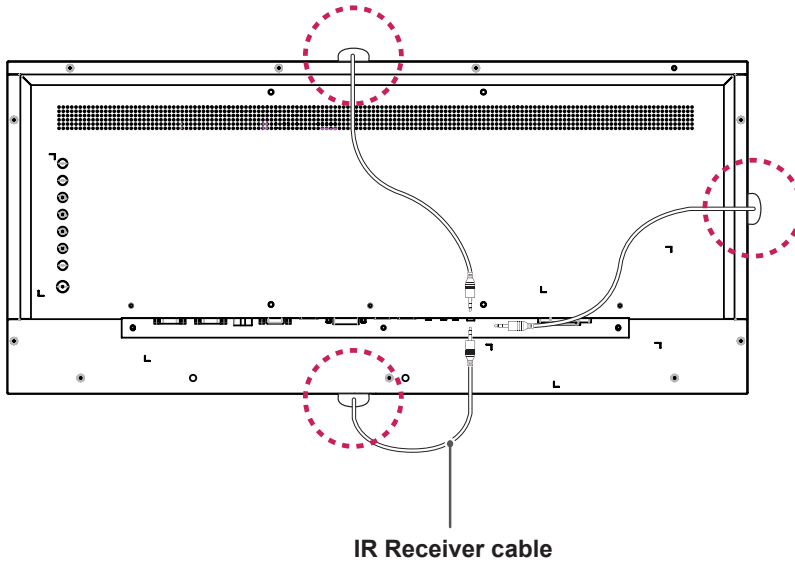

! NOTE

- The IR receiver is made with a magnet. You can attach the IR receiver on the side, top, or bottom of the product.
- It may fall down if exposed to external shock.

Mounting on a wall

For proper ventilation, allow a clearance of 10 cm on each side and from the wall. Detailed installation instructions are available from your dealer, see the optional Tilt Wall Mounting Bracket Installation and Setup Guide.

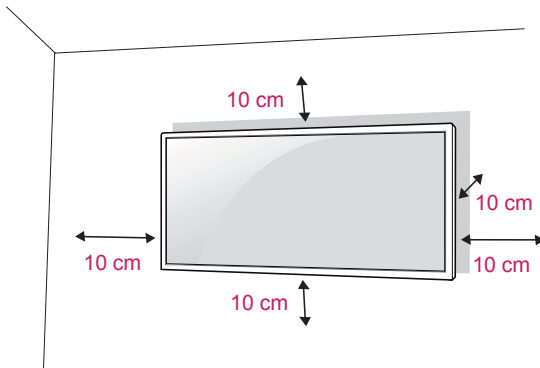

To install the monitor to a wall, attach a wall mounting bracket (optional) to the back of the monitor. Make sure that the wall mounting bracket is securely fixed to the monitor and to the wall.

- 1 Use the screws and wall mounting bracket that comply with the VESA standard.
- 2 Screws which are longer than the standard length may damage the inside of the monitor.
- 3 A non-VESA standard screw may damage the product and cause the monitor to fall. LG Electronics is not liable for any accidents relating to the use of non-standard screws.
- 4 VESA compatible only with respect to screw mounting interface dimensions and mounting screw specifications.
- 5 Please use VESA standard as below.
 - 784.8 mm (30.9 inch) and under
 - * Wall Mount Pad Thickness : 2.6 mm
 - *Screw : Φ 4.0 mm x Pitch 0.7 mm x Length 10 mm



CAUTION

- Unplug the power cord before moving or installing the monitor to avoid electric shocks.
- Installing the monitor on the ceiling or on a slanted wall may result in the monitor falling off, which could lead to injury. Please use the genuine LG wall mounting bracket. For more information, contact your local retail store or a qualified installer.
- Applying excessive force when fastening screws may cause damage to the monitor. Damage caused in this way will not be covered by the product warranty.
- Use the wall mounting bracket and screws that conform to the VESA standard. Damage caused by the use or misuse of inappropriate components will not be covered by the product warranty.
- Installing a monitor lengthwise may damage the pixels on the screen.
- To prevent injury, this apparatus must be securely attached to the wall in accordance with the installation instructions. (This only pertains to Australia and New Zealand.)



CAUTION

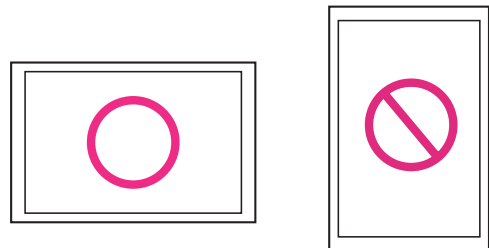

- Installing a monitor lengthwise may damage the pixels on the screen.



NOTE

- The wall mount kit includes the installation guide and all necessary parts.
- The wall mounting bracket is optional. The accessories can be purchased at your local retail store.
- The length of the screw may differ for each wall mounting bracket. Ensure the correct length screw is used.
- For more information, please refer to the user manual for the wall mounting bracket.

REMOTE CONTROL

The descriptions in this manual are based on the buttons of the remote control. Please read this manual carefully and use the Monitor correctly.

To replace batteries, open the battery cover, replace batteries (1.5 V AAA) matching ⊕ and ⊖ ends to the label inside the compartment, and close the battery cover.

To remove the batteries, perform the installation actions in reverse.



CAUTION

- Do not mix old and new batteries, as this may damage the remote control.
- Make sure to point the remote control at the remote control sensor on the Monitor.

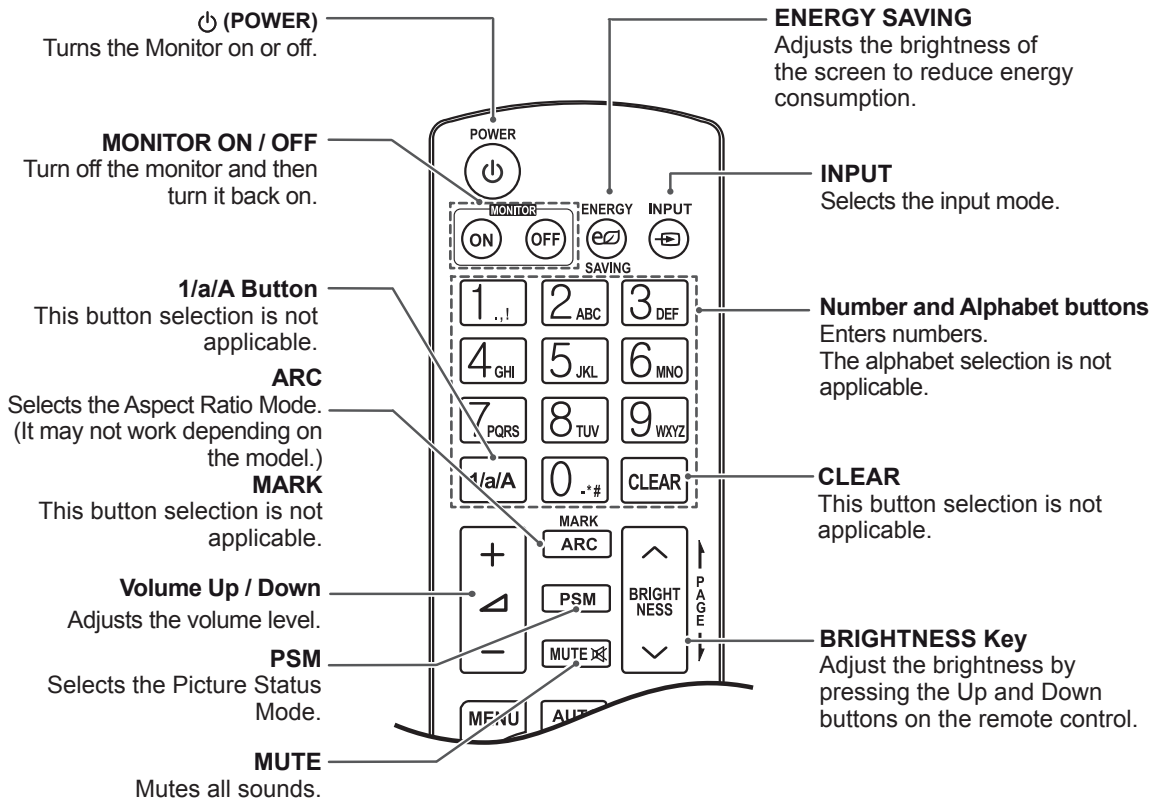
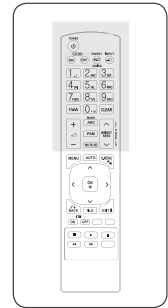
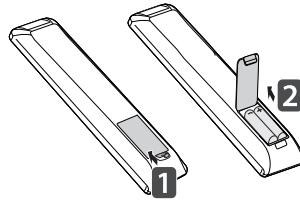

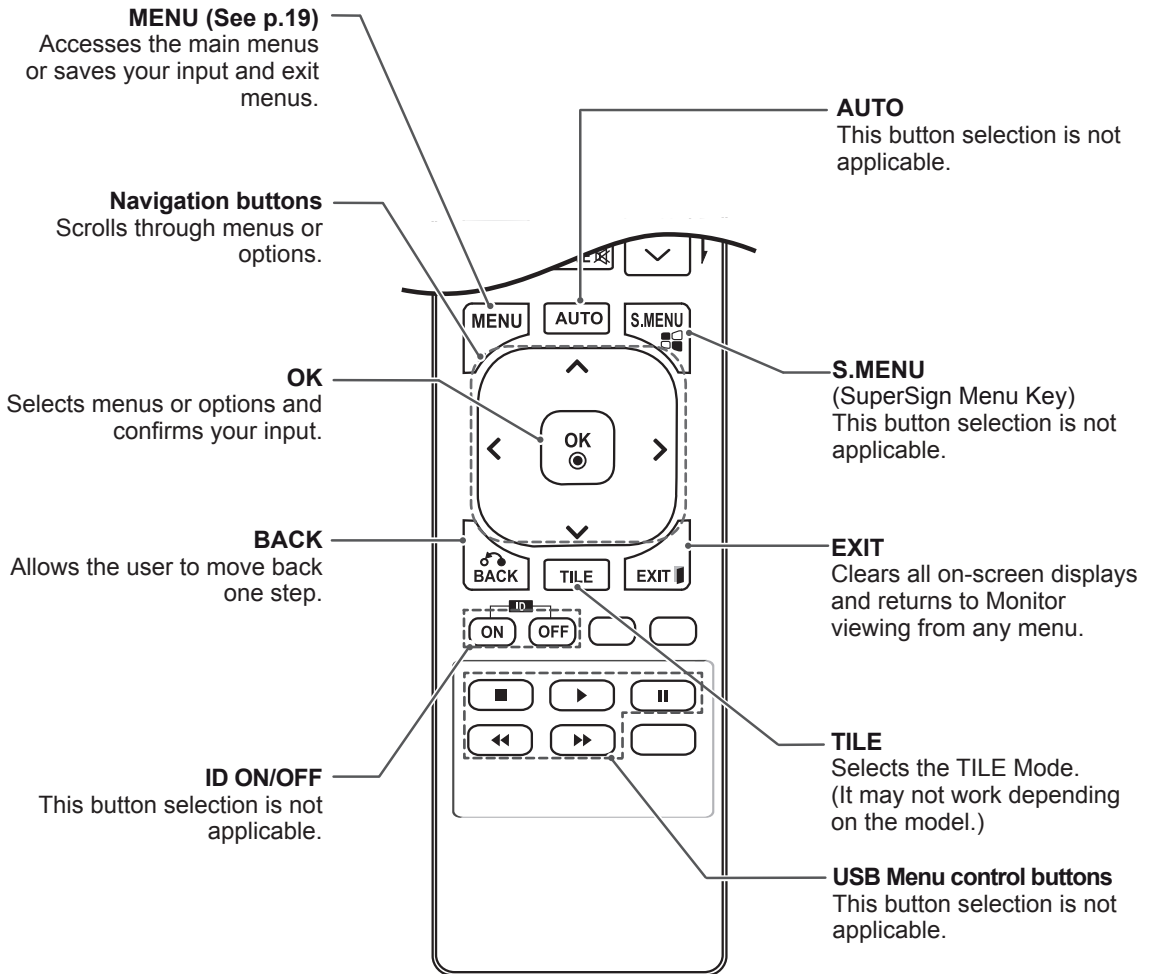
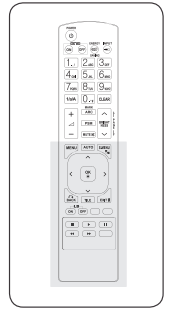

USING THE MONITOR

Connecting to a PC

Your Monitor supports the Plug & Play* feature.

* Plug & Play: This is the function that allows a PC to use the monitor without installing a driver.

NOTE

- It is recommended to use the Monitor with the HDMI connection for the best image quality.
- Use a shielded signal interface cable, such as DVI/HDMI cable, with a ferrite core to maintain standard compliance for the product.
- If you turn the Monitor on when the set becomes cold, the screen may flicker. This is normal.
- Some red, green, or blue spots may appear on the screen. This is normal.

CAUTION

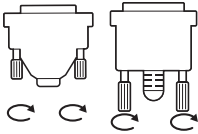

- Connect the signal input cable and tighten it by turning the screws clockwise.
- Do not press the screen with your finger for a long time as this may result in temporary distortion on the screen.
- Avoid displaying a fixed image on the screen for a long period of time to prevent image burn. Use a screensaver if possible.

DVI connection

Transmits digital video signals to the monitor. Connect the monitor using the DVI cable as illustrated below. Select the DVI input after connecting. To transmit an audio signal, connect additional audio cables.

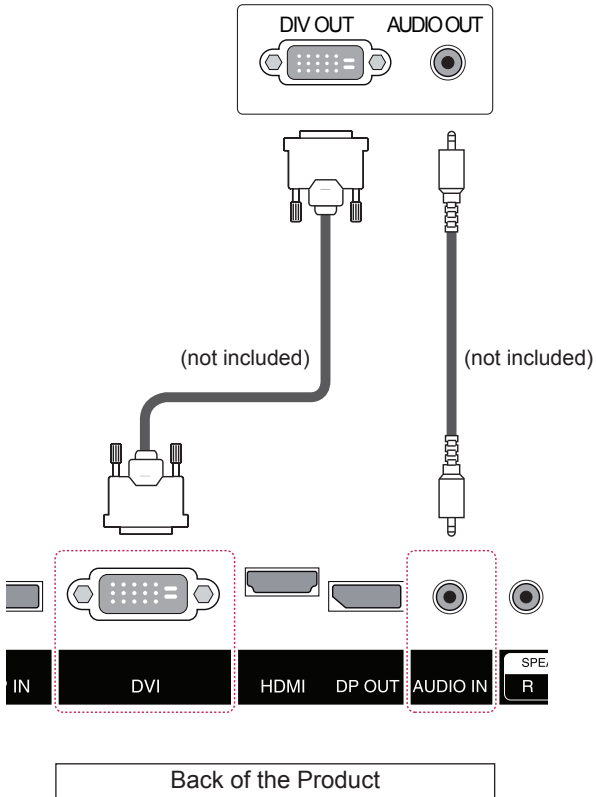

Display Port connection

Transmits the digital video and audio signals from your PC to the Monitor. Connect the PC and the Monitor with the Display Port cable as shown in the following illustrations.

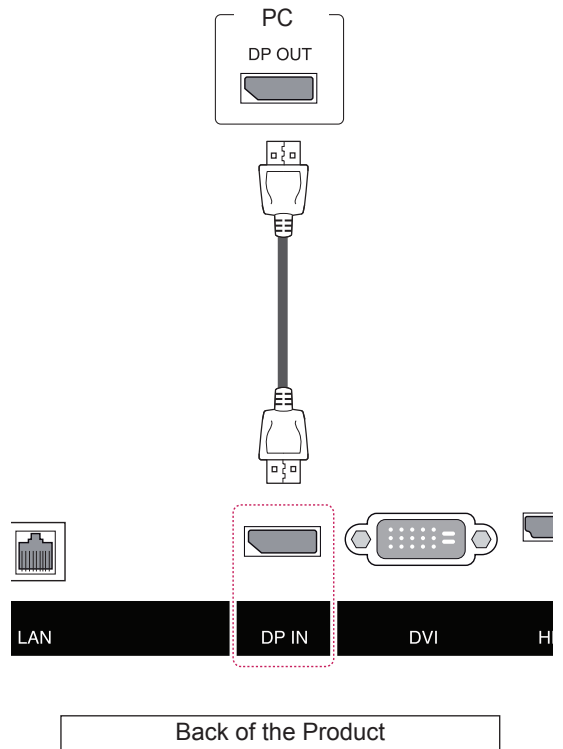

HDMI connection

Transmits the digital video and audio signals from your PC and A/V devices to the monitor. Connect your PC and AV device to the monitor with the HDMI cable as illustrated below.

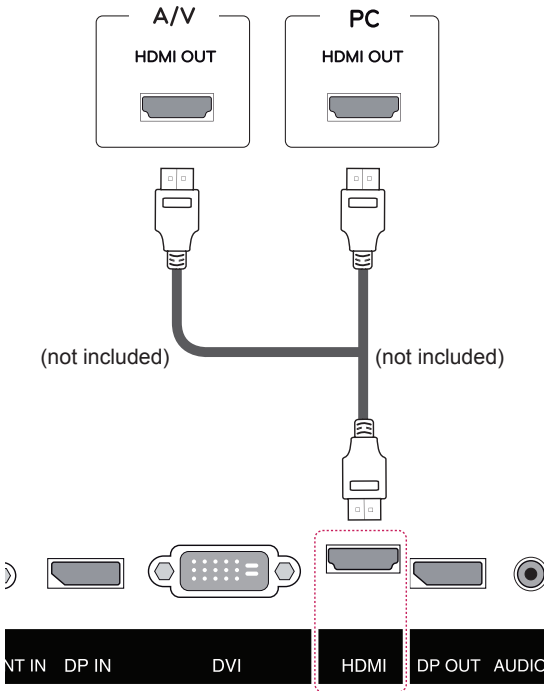

Back of the Product

IR Receiver connection

Allows the use of a wired remote or IR receiver extension.

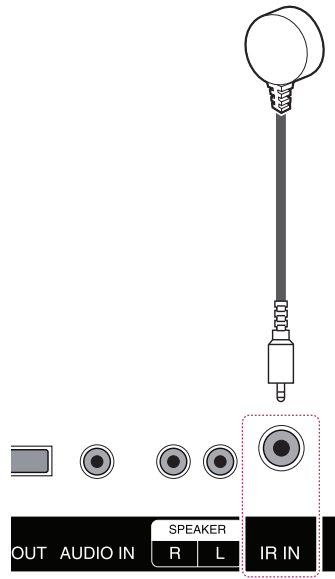

Back of the Product

NOTE

- Use a High Speed HDMI™ cable.
- High Speed HDMI™ cables transmit an HD signal up to 1080p and higher.
- Please check your PC settings if you cannot hear any sound in HDMI mode. Some PCs require you to manually change the default audio output to HDMI.

NOTE

- Make sure the power cable is disconnected.

LAN connection

A Using a router(Switch)

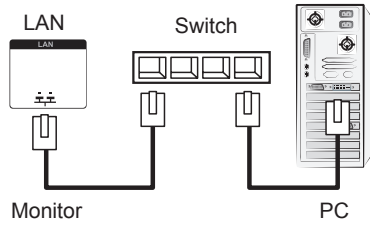

B Using the Internet.

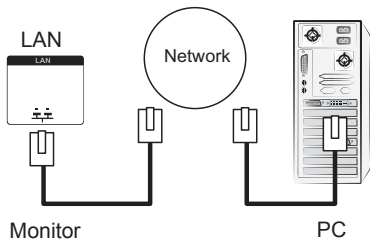

Daisy Chain Monitors

This function displays digital video signals from your PC on multiple monitors.

- 1 Connect a signal input cable (DVI cable) to the DVI IN port of Monitor 1.
- 2 Connect the other end of the signal input cable to your PC.
- 3 Connect one end of another signal input cable to the DIV OUT port of Monitor 1 and the other end to the DIV IN of Monitor 2.

DP Cable

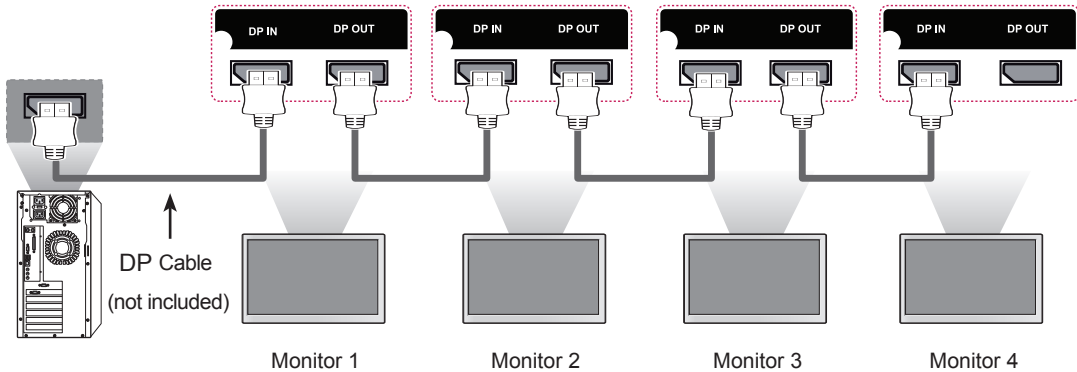

NOTE

- The number of monitors that can be connected to one output may vary depending on signal strength and signal loss. If you want to connect more than this number of monitors, it is recommended to use a distributor.
- It is also recommended to use lossless cables when linking multiple monitors through the in/out ports.
- The DP OUT port does not work for third party devices. Use DP version 1.1 (Menu→Settings→DP1.2→Off) when linking multiple monitors through the in/out ports.
- Up to 40 monitors can be connected in the DP mode. (When using the Display Port cable provided by LG Electronics.)

Using additional options

Adjusting aspect ratio

Resize the image to view the image at its optimal size by pressing **ARC** while you are watching content.



CAUTION

- If a fixed image displays on the screen for a long period of time, it will be imprinted and become a permanent disfigurement on the screen. This is “image burn” or “burn-in” and not covered by the warranty.
- To prevent image sticking, do not play a still image for more than two hours.
- If the aspect ratio is set to Original or 1:1 for a long period of time, image burn may occur on the letterboxed area of the screen.



NOTE

- You can also change the image size by accessing the main menus.

ENTERTAINMENT

Connecting to a wired network

(Depending on model)

Connect the display to a local area network (LAN) via the LAN port as shown on the following illustration and set up the network settings.

This monitor only supports a wired network connection.

After making a physical connection, a small number of home networks may require the display network settings to be adjusted. For most home networks, the display will connect to automatically without any adjustments.

For detail information, contact your internet provider or router manual.

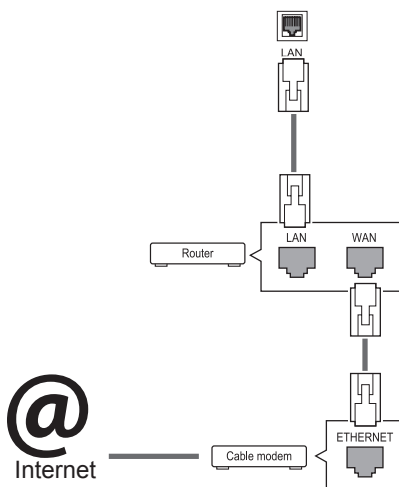

! CAUTION

- Do not connect a modular phone cable to the LAN port.
- Since there are various connection methods, please follow the specifications of your telecommunication carrier or internet service provider.

To set up the network settings: (Even if your display has already connected automatically, running setup again will not harm anything),

- 1 Press **MENU** to access the main menus.
- 2 Press the Navigation buttons to scroll to **NETWORK** and press **OK**.
- 3 Press the Navigation buttons to select **Network Setting** and press **OK**. If Interface Select is set to RS-232C, change the Interface Select setting to LAN.
- 4 Select **DHCP** or **Customer Setting**.
 - If selecting **Customer Setting**, press the Navigation and Number buttons. IP addresses will need to be input manually.
 - Press OK and use Up, Down, Number keys to change the values. Press OK again to finish changing values.
 - **DHCP**: Select this if there is a DHCP server (Router) on the local area network (LAN) via wired connection, the display will automatically be allocated an IP address. If you're using a broadband router or broadband modem that has a DHCP (Dynamic Host Configuration Protocol) server function. The IP address will automatically be determined.
- 5 When you are finished, press **EXIT**.

! CAUTION

- Network setting menu will not be available until the display is connected to physical network.
- Since there are various connection methods, please follow the specifications of your telecommunication carrier or internet service provider.

**NOTE**

- If you want to access the Internet directly on your display, the internet connection should always be on.
- If you cannot access the Internet, check the network conditions from a PC on your network.
- When you use **Network Setting**, check the LAN cable or check if DHCP in the router is turned on.

Tips for Network setting

- Use a standard LAN cable with this display. Cat5 or better with a RJ45 connector.
- Many network connection problems during set up can often be fixed by re-setting the router or modem. After connecting the display to the home network, quickly power off and/or disconnect the power cable of the home network router or cable modem. Then power on and/or connect the power cable again.
- Depending on the internet service provider (ISP), the number of devices that can receive internet service may be limited by the applicable terms of service. For details, contact your ISP.
- LG is not responsible for any malfunction of the display and/or the internet connection feature due to communication errors/malfunctions associated with your internet connection, or other connected equipment.
- LG is not responsible for problems within your internet connection.
- You may experience undesired results if the network connection speed does not meet the requirements of the content being accessed.
- Some internet connection operations may not be possible due to certain restrictions set by the Internet service provider (ISP) supplying your Internet connection.
- Any fees charged by an ISP including, without limitation, connection charges are your responsibility.
- A 10 Base-T or 100 Base-TX LAN port is required when using a wired connection to this display. If your internet service does not allow for such a connection, you will not be able to connect the display.
- A DSL modem is required to use DSL service and a cable modem is required to use cable modem service. Depending on the access method of and subscriber agreement with your ISP, you may not be able to use the internet connection feature contained in this display or you may be limited to the number of devices you can connect at the same time. (If your ISP limits sub-cription to one device, this display may not be allowed to connect when a PC is already connected.)
- The use of a “Router” may not be allowed or its usage may be limited depending on the policies and restrictions of your ISP. For details, contact your ISP directly.

CUSTOMIZING SETTINGS

Menu Settings

- 1 To view the **Menu** OSD, press the **Menu** button at the bottom of the monitor.
- 2 Use the < or > buttons to set the options.
- 3 Select  button to exit the OSD menu.



Brightness Contrast Volume Input Ratio Func. PIP



Picture Color Settings Time Network Reset Exit

Each option is described below.

Menu	Description
Brightness	Adjusts the brightness and contrast of the screen.
Contrast	
Volume	Adjusts the volume.
	<div style="border: 1px solid black; padding: 5px;"> <p> NOTE</p> <ul style="list-style-type: none"> • Selecting the Menu button in the Volume menu will enable/disable the Mute function. </div>
Input	Selects the current input mode.
Ratio	Adjusts the screen ratio.
Func.	Adjusts ECO, and picture mode.
PIP	Displays the screens of two input modes on one monitor.
Picture	Adjusts the sharpness, black level, and response time of the screen.
Color	Adjusts the gamma, color temperature, and color balance of the screen.
Settings	Sets the Language, PC/AV mode, Main Audio, Tile Mode, ISM Method, Key Lock, Set ID, DPM Select, Information, and OSD Lock. (Tile mode may not work depending on the model.)
Time	Sets the On/Off timer, Auto off, 4 Hours Off, and Sleep Timer.
Network	Sets the RS-232C and LAN.
Reset	Resets to the default settings as of the day of purchase. Press the <, > buttons to reset immediately.
Exit	Exits the OSD menu.

Ratio Settings

- 1 To view the **Menu** OSD, press the **Menu** button at the bottom of the monitor.
- 2 Press < or > to go to **Ratio**.
- 3 Press **OK** to select **Ratio**.
- 4 Use the < or > buttons to set the options.
- 5 Select  to exit the OSD menu.



Ratio

Sub Menu



Wide

Cinema1

Cinema2

Original

1:1

Back

Exit

Each option is described below.

Menu > Ratio	Description
Wide	Displays the video in wide-screen, regardless of the video signal input.
Cinema1	Enlarges the screen with an aspect ratio of 21:9. (at 1080p)
Cinema2	Enlarges the screen with an aspect ratio of 21:9 including the black box area at the bottom for subtitles. (at 1080p)
Original	Displays a video according to the input video signal aspect ratio.
1:1	The aspect ratio is not adjusted from the original.
Back	Moves to the previous OSD screen.
Exit	Exits the OSD menu.



NOTE

- The display may look the same for Wide, Original and 1:1 options at the recommended resolution (2560 x 1080).
- The ratio is disabled in the interlaced signal.

Func. Settings

- 1 To view the **Menu** OSD, press the **Menu** button at the bottom of the monitor.
- 2 Press < or > to go to **Func.**
- 3 Press **OK** to select **Func.**
- 4 Use the < or > buttons to set the options.
- 5 Select  to exit the OSD menu.



Func.

Sub Menu

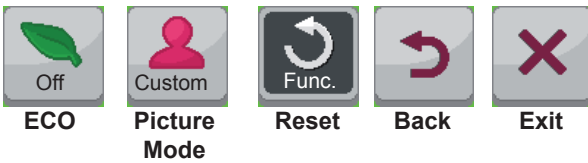

Each option is described below.

Menu > Func.	Description	
ECO	On	Enables the ECO function, which allows you to save energy according to the ECO efficiency level.
	Off	Disables the ECO function.
	Reset	Resets the ECO data.
Picture Mode	Changes depending on the value of PC/AV Mode in Menu > Settings.	
	PC Mode	
	Custom	Allows the user to adjust each element. The color mode of the main menu can be adjusted.
	Text	Optimizes the screen for document processing.
	Photo	Optimizes the screen to view photos.
	Cinema	Optimizes the screen to improve the visual effects of a video.
	Game	Optimizes the screen for gameplay.
	AV Mode	
	Custom	Allows the user to adjust each element. The color mode of the main menu can be adjusted.
	Standard	Optimizes the screen to display normal picture quality.
	VIVID 1	Optimizes the screen for vivid visual effects.
VIVID 2	Optimizes the screen for more vivid visual effects.	
Cinema	Optimizes the screen to improve the visual effects of a video.	
Reset	Func. Resets the monitor to its original factory settings.	
Back	Moves to the previous OSD screen.	
Exit	Exits the OSD menu.	

PIP settings

- 1 To view the **Menu** OSD, press the **Menu** button at the bottom of the monitor.
- 2 Press < or > to go to **PIP**.
- 3 Press **OK** to select **PIP**.
- 4 Use the < or > buttons to set the options.
- 5 Select  to exit the OSD menu.



PIP

Sub Menu



Each option is described below.

Menu > PIP	Description
PIP	Displays the screens of two input modes on one monitor. (DVI+DP, HDMI1+DP, HDMI2+DP, DP+DVI, DP+HDMI1, DP+HDMI2)
Size	Adjusts the size of the secondary screen.
	Balanced Uses a balanced size for the secondary screen.
	Small Shows the secondary screen in a small size display.
	Medium Shows the secondary screen in a normal size display.
	Large Shows the secondary screen in a large size display.
	16:9VS5:9 Shows 16:9 widescreen on the Main screen. Shows 5:9 widescreen on the Subscreen.
Position	Adjusts the position of the secondary screen. The default value is Bottom Right.
	Bottom Right Shows the secondary screen in the bottom right of the display.
	Bottom Left Shows the secondary screen in the bottom left of the display.
	Top Left Shows the secondary screen in the top left of the display.
	Top Right Shows the secondary screen in the top right of the display.
	Reset Resets the PIP function to the default settings.
Back Moves to the previous OSD screen.	
Exit Exits the OSD menu.	

 **NOTE**

- If the PIP mode is off, Position is disabled.
- If Size is set to Balance, Position is disabled.

PIP/PBP

Displays videos or photos stored in the USB device on a single monitor by dividing it into the main and sub screens.

Mode

***PIP (Picture In Picture)**: Displays the Sub screen in the main screen.

***PBP (Picture by Picture)**: Splits the display into the main screen and a sub screen.

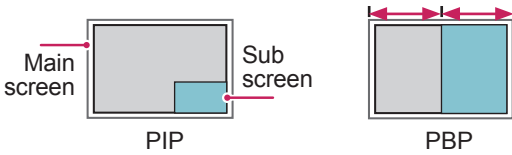

Position

Adjusts the position of the subscreen (top left, bottom left, top right, bottom right)

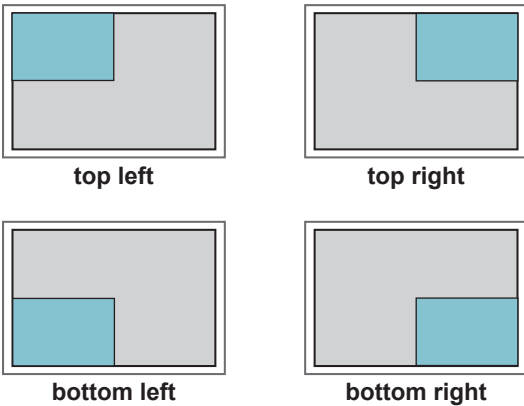

top left

top right

bottom left

bottom right

Size

Adjusts the size of the subscreen.

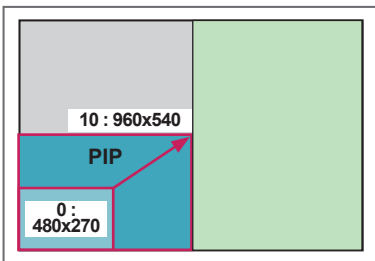

Picture

- 1 To view the **Menu** OSD, press the **Menu** button at the bottom of the monitor.
- 2 Press < or > to go to **Picture**.
- 3 Press **OK** to select **Picture**.
- 4 Use the < or > buttons to set the options.
- 5 Select  to exit the OSD menu.



Picture

Sub Menu

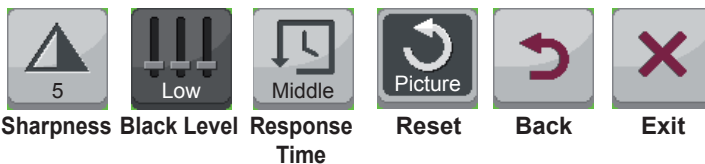

Sharpness Black Level Response Time

Reset

Back

Exit

Each option is described below.

Menu > Picture	Description
Sharpness	Adjusts the sharpness of the screen.
Black Level	Sets the offset level (for HDMI only). Offset: as a reference for a video signal, this is the darkest color the monitor can display.
	High The picture of the screen gets brighter.
	Low The picture of the screen gets darker.
Response Time	Sets a response time for displayed pictures based on the speed of the screen. For a normal environment, it is recommended that you use Normal. For a fast-moving picture, it is recommended that you use High. Setting to High may cause image sticking.
	High Sets the response time to High.
	Middle Sets the response time to Middle.
	Low Sets the response time to Low.
Reset	Resets the Picture function to the default settings.
Back	Moves to the previous OSD screen.
Exit	Exits the OSD menu.

Color

- 1 To view the **Menu** OSD, press the **Menu** button at the bottom of the monitor.
- 2 Press < or > to go to **Color**.
- 3 Press **OK** to select **Color**.
- 4 Use the < or > buttons to set the options.
- 5 Select  to exit the OSD menu.
To return to the upper menu or set other menu items, use the **Menu** button.



Color

Sub Menu



Each option is described below.

Menu > Color	Description
Gamma	Custom gamma setting: When using the gamma 0, gamma 1, and gamma 2 monitor settings, higher gamma settings mean a brighter image is displayed and vice versa.
Color Temp	<p>Custom</p> <p>Red Green Blue</p> <p>You can customize the picture color using Red, Green, and Blue colors.</p> <p>Selects the factory default picture color. Warm: Sets the screen color to a reddish tone. Medium: Sets the screen color between a red and blue tone. Cool: Sets the screen color to a bluish tone.</p>
Six Color	<p>Meets the user requirements for colors through adjusting the color and saturation of the six colors (red, green, blue, cyan, magenta, yellow) and saving the settings.</p> <p>Hue</p> <p>Adjusts tone of the screen.</p> <p>Satura-tion</p> <p>Adjusts the saturation of the screen colors. The lower the value, less saturated and bright the colors become. The higher the value, the more saturated and dark the colors become.</p>
Reset	Returns the color settings to the default settings.
Back	Moves to the previous OSD screen.
Exit	Exits the OSD menu.

Settings

- 1 To view the **Menu** OSD, press the **Menu** button at the bottom of the monitor.
- 2 Press < or > to go to **Settings**.
- 3 Press **OK** to select **Settings**.
- 4 Use the < or > buttons to set the options.
- 5 Select  to exit the OSD menu.



Settings

Sub Menu

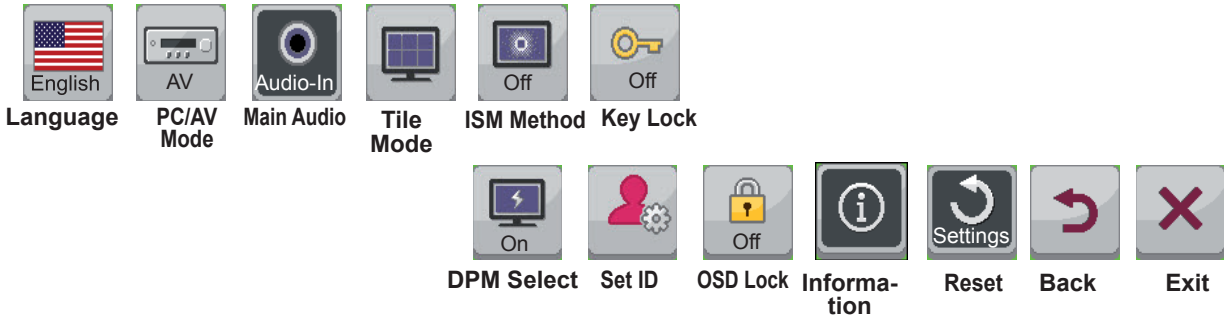

Each option is described below.

Menu > Settings	Description				
Language	Sets the menu screen to the desired language.				
PC/AV Mode	Enabled in HDMI mode only.				
Main Audio	The sound coming through the Audio In port of the digital input signal (HDMI, HDMI2/MHL, Display Port) can be heard through the monitor's speakers. Audio port is converted into the main audio port when the input is changed.				
Tile Mode	Sets the Tile Mode, Tile ID, and Natural Mode. (It may not work depending on the model.)				
ISM Method	Sets the functionality of preventing afterimage on the screen.				
Key Lock	Turns the local key function on or off. If this function is enabled, the local key does not work.				
DPM Select	A user can choose to turn the power saving mode on / off.				
Set ID	You can assign a unique Set ID NO (name assignment) to each product when several products are connected for display. Specify the number (1 to 255) using the button and exit. Use the assigned Set ID to individually control each product using the Product Control Program.				
OSD Lock	Prevents incorrect key input. <table border="1" style="width: 100%; margin-top: 5px;"> <tr> <td>On</td> <td>Key input is disabled.</td> </tr> <tr> <td>Off</td> <td>Key input is enabled.</td> </tr> </table> <div style="border: 1px solid black; padding: 5px; margin-top: 10px;"> <p> NOTE — All functions except for the OSD Lock mode and the Exit button for Brightness, Contrast, Volume, Input, and Settings are disabled.</p> </div>	On	Key input is disabled.	Off	Key input is enabled.
On	Key input is disabled.				
Off	Key input is enabled.				
Information	See the serial number, S/W version, LAN version, IP address, and MAC address.				
Reset	Resets the settings to default.				
Back	Moves to the previous OSD screen.				
Exit	Exits the OSD menu.				

Tile Mode

This monitor can be tiled with additional monitors to create a large tiled display.

Off

When the Tile Mode option is disabled

1X2

When using 2 monitors



2X2

When using 4 monitors



Tile Mode - Natural mode

When active, the part of the image that would normally be displayed in the gap between the monitors is omitted.

Before



After



Time

- 1 To view the **Menu** OSD, press the **Menu** button at the bottom of the monitor.
- 2 Press < or > to go to **Settings**.
- 3 Press **OK** to select **Settings**.
- 4 Use the < or > buttons to set the options.
- 5 Select  to exit the OSD menu.



Time

Sub Menu

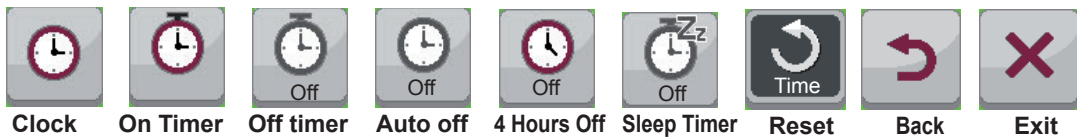

Each option is described below.

Menu > Time	Description
Clock	Sets the time feature.
Off/On Time	Sets the time to turn on or off the Monitor.
Auto off	If Auto off is active and there is no input signal, the set switches to off mode automatically after 15 minutes.
4 Hours Off	If you do not use the monitor for more than 4 hours, it will be in off mode automatically.
Sleep Timer	Sets the length of time until the Monitor to turns off. When you turn the Monitor off and turn it on again, the Sleep Timer will be set to off.

NOTE

- Off/On Time can be saved for up to seven schedules; the Monitor is turned on or off at the preset time in the schedule list. If multiple preset times are stored in the schedule list, this function works at the nearest time from the current time.
- The scheduled power-off function works properly only when the device time is set correctly.
- When the scheduled power-on and power-off times are the same, the power-off time has priority over the power-on time if the set is turned on, and vice versa if the set is turned off.
- "The ""Automatic Standby"" and ""Auto off"" functions may not be available in some countries."

Network

- 1 To view the **Menu** OSD, press the **Menu** button at the bottom of the monitor.
- 2 Press < or > to go to **Settings**.
- 3 Press **OK** to select **Settings**.
- 4 Use the < or > buttons to set the options.
- 5 Select  to exit the OSD menu.



Network

Sub Menu



**Interface
Select**



**Network
Setting**



Back



Exit

Each option is described below.

Menu > Network	Description	
Interface Select	Sets communication with Media Player and the connected PC.	
	RS-232C	Communicates with the connected PC in serial mode.
	LAN	Communicates with Media Player.
Network Setting	Configure the network settings.	
Back	Moves to the previous OSD screen.	
Exit	Exits the OSD menu.	

TROUBLESHOOTING

No image is displayed

Problem	Resolution
Is the product power cord connected?	<ul style="list-style-type: none"> • See if the power cord is properly connected to the outlet.
Does the 'Out of range' message appear?	<ul style="list-style-type: none"> • The signal from the PC (video card) is out of the vertical or horizontal frequency range of the product. Adjust the frequency range by referring to the Specifications in this manual. * Maximum resolution HDMI/DVI: 2560 x 1080(60Hz)
Does the 'Check signal cable' message appear?	<ul style="list-style-type: none"> • The signal cable between PC and product is not connected. Check the signal cable. • Press the 'INPUT' menu in the remote Control to check the input signal.

'Unknown Product' message appears when the product is connected.

Problem	Resolution
Did you install the driver?	<ul style="list-style-type: none"> • See if the plug&play function is supported by referring to the video card user manual.

'Key Lock On' message appears.

Problem	Resolution
The 'Key Lock On' message appears when pressing the Menu button.	The Lock function prevents the OSD settings from being changed inadvertently. To release the lock, go to Menu and Option and disable the Key Lock option.

The screen image looks abnormal.

Problem	Resolution
Is the screen position wrong?	<ul style="list-style-type: none"> • See if the video card resolution and frequency are supported by the product. If the frequency is out of range, set to the recommended resolution in the Control Panel "Display" Setting menu.
The screen is displayed abnormally.	<ul style="list-style-type: none"> • The proper input signal is not connected to the signal port. Connect the signal cable that matches with the source input signal.

After-image appears on the product.

Problem	Resolution
After-image appears when the product is turned off.	<ul style="list-style-type: none"> • If you use a fixed image for a long time, the pixels may be damaged quickly. Use the screen-saver function. • When a dark image is displayed on the screen after an image with high contrast (black and white or gray), this may cause image sticking. This is normal for LCD screen.

The audio function does not work.

Problem	Resolution
No sound?	<ul style="list-style-type: none"> • See if the audio cable is connected properly. • Adjust the volume. • See if the sound is set properly.
Sound is too low.	<ul style="list-style-type: none"> • Adjust the volume.

Screen color is abnormal.

Problem	Resolution
Screen has poor color resolution (16 colors).	<ul style="list-style-type: none"> • Set the number of colors to more than 24 bits (true color) Select Control Panel - Display - Settings - Color Table menu in Windows.
Screen color is unstable or mono-colored.	<ul style="list-style-type: none"> • Check the connection status of the signal cable. Or, re-insert the PC video card.
Do black spots appear on the screen?	<ul style="list-style-type: none"> • Several pixels (red, green, white or black color) may appear on the screen, which can be attributable to the unique characteristics of the LCD panel. It is not a malfunction of the LCD.

The operation does not work normally.

Problem	Resolution
The power suddenly turned off.	<ul style="list-style-type: none"> • Is the sleep timer set? • Check the power control settings. Power interrupted

SPECIFICATIONS

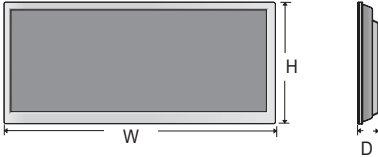
LCD Panel	Screen Type	1064.67 mm Wide (29 inch) TFT (Thin Film Transistor) LCD (Liquid Crystal Display) Panel. Visible diagonal size : 1064.67 mm
	Pixel Pitch	0.4833 mm (H) x 0.4833 mm (V)
Video Signa	Max. Resolution	2560 x 1080 @ 60 Hz - It may not be supported depending on the OS or video card type.
	Recommended Resolution	2560 x 1080 @ 60 Hz - It may not be supported depending on the OS or video card type.
	Horizontal Frequency	30 kHz to 90 kHz
	Vertical Frequency	56 Hz to 75 Hz
	Synchronization Type	Separate Sync, Composite Sync, Digital
Input Connector	HDMI(Digital), RS-232C, LAN, DVI, DP, Audio, Speaker, IR Receiver	
Power	Rated Voltage	AC 100-240 V~ 50/60 Hz 0.6 A
	Power Consumption	On Mode : 53 W Typ. Sleep Mode : ≤ 1.2 W Off Mode : ≤ 0.5 W
Environmental conditions	Operating Temperature	10 °C to 35 °C
	Operating Humidity	10 % to 80 %
	Storage Temperature	-20 °C to 60 °C
	Storage Humidity	5 % to 90 %
Dimensions (Width x Height x Depth) / Weight		
	697.2 mm x 313.2 mm x 50.9 mm / 7.2 kg	

*** Applicable only for models that support the speakers**

Audio	RMS Audio Output	10 W + 10 W (R + L)
	Input Sensitivity	0.7 Vrms
	Speaker Impedance	8 Ω

Product specifications shown above may be changed without prior notice due to upgrade of product functions.

Dimensions

The illustrations in this manual may differ from the actual product and accessories. Please see the "Mounting on a wall" section for sizes of screws. (See p.8)

(Unit : mm)

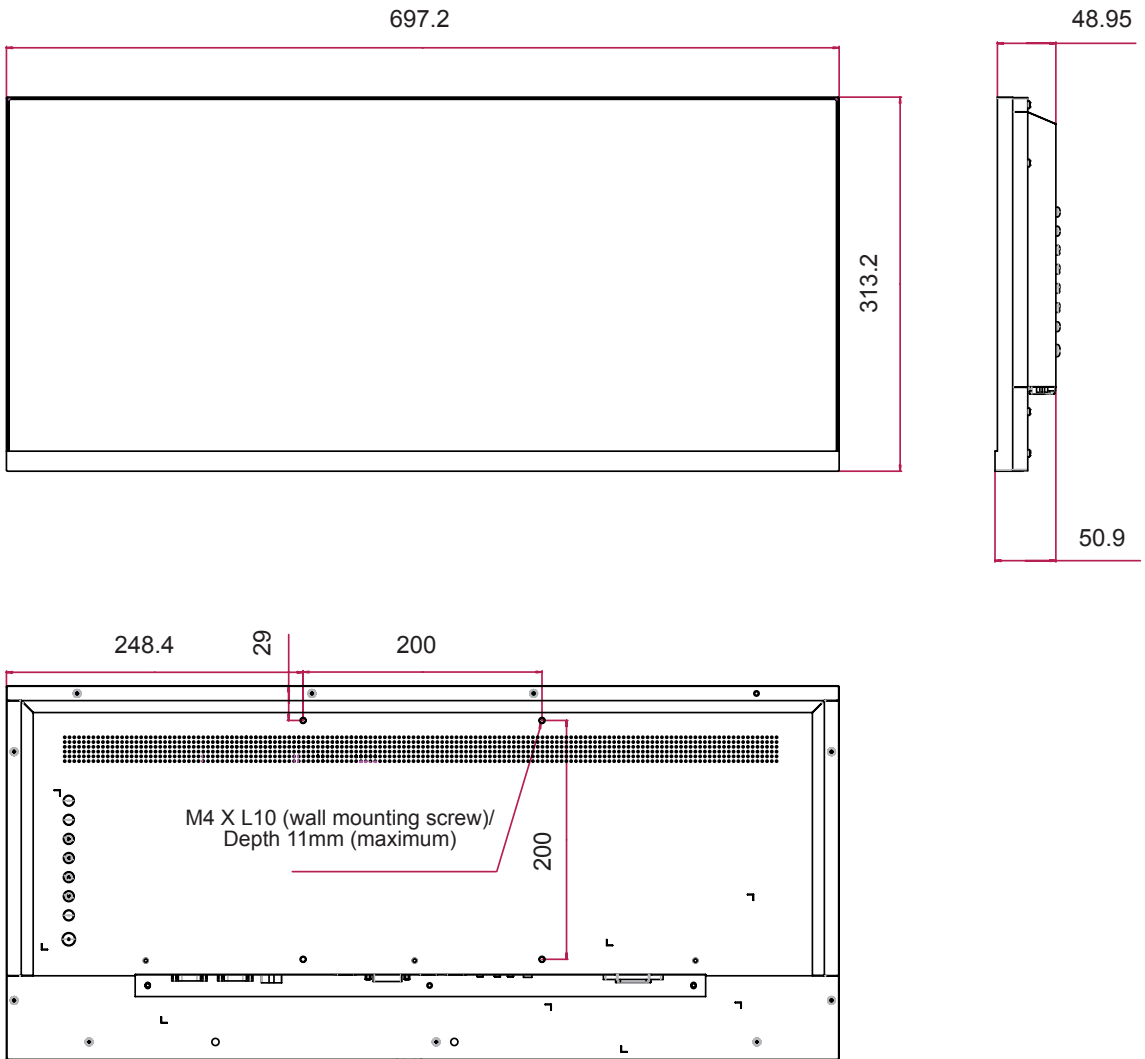

Product specifications shown above may be changed without prior notice due to upgrade of product functions.

DVI/Display Port/HDMI(PC) supported mode.

Resolution	Horizontal Frequency(kHz)	Vertical Frequency(Hz)
720 x 400	31.468	70.08
640 x 480	31.469	59.94
640 x 480	37.5	75
800 x 600	37.879	60.317
800 x 600	46.875	75.0
1024 x 768	48.363	60.0
1024 x 768	60.123	75.029
1152 x 864	67.5	75
1280 x 720	45	60
1280 x 1024	63.981	60.02
1280 x 1024	79.976	75.025
1680 x 1050	65.29	59.954
1920 x 1080	67.5	60
2560 x 1080	66.7	60

AV Mode

Resolution	HDMI
480i	x
576i	x
480p	o
576p	o
720p	o
1080i	o
1080p	o

! NOTE

- PC resolutions available for HDMI (PC)/DVI input mode: 640 x 480/60 Hz, 1280 x 720/60 Hz, 1920 x 1080/60 Hz; 480p, 720p and 1080p DTV resolutions.

! NOTE

- Vertical frequency: To enable the user to watch the product display, screen image should be changed tens of times every second like a fluorescent lamp. The vertical frequency or refresh rate is the times of image display per second. The unit is Hz.
- Horizontal frequency: The horizontal interval is the time to display one vertical line. When 1 is divided by the horizontal interval, the number of horizontal lines displayed every second can be tabulated as the horizontal frequency. The unit is kHz.

CONTROLLING THE MULTIPLE PRODUCT

- Use this method to connect several products to a single PC. You can control several products at a time by connecting them to a single PC.
- In the Option menu, Set ID must be between 1 and 99 without being duplicated.

Connecting the cable

Connect the RS-232C cable as shown in the picture.

- The RS-232C protocol is used for communication between the PC and product. You can turn the product on/off, select an input source or adjust the OSD menu from your PC.

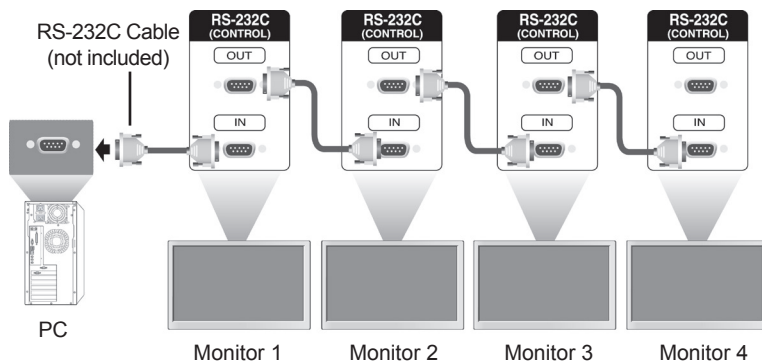

RS-232C Configurations

7-Wire Configurations (Standard RS-232C cable)

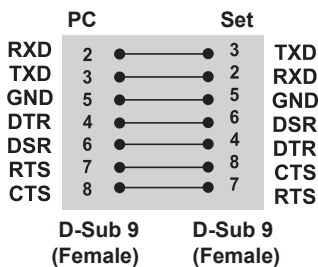

3-Wire Configurations (Not Standard)

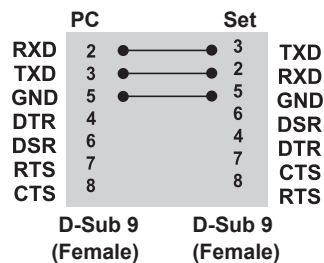

Communication Parameter

- Baud Rate : 9600 BPS
- Data Length : 8 bit
- Parity Bit : None
- Stop Bit : 1bit
- Flow Control : None
- Communication Code : ASCII code
- Use a crossed (reverse) cable

Command Reference List

- Some commands are not supported depending on the model.

		COMMAND		DATA (Hexadecimal)
		1	2	
01	Power	k	a	00H to 01H
02	Input Select	x	b	See '02. Input Select'
03	Ratio	k	c	See '03. Ratio'
04	Picture Mode	d	x	See '04. Picture Mode'
05	Contrast	k	g	00H to 64H
06	Brightness	k	h	00H to 64H
07	Sharpness	k	k	00H to 0AH
08	Color Temp	x	u	00H to 03H
09	MUTE	k	e	00H to 01H
10	Volume	k	f	00H to 64H
11	Clock 1 (year/month/day)	f	a	See '11. Clock 1'
12	Clock 2 (hour/minute/second)	f	x	See '12. Clock 2'
13	Off Timer (repeat mode/time)	f	e	See '13. Off Timer'
14	On Timer (repeat mode/time)	f	d	See '14. On Timer'
15	On Timer Input	f	u	See '15. On Timer Input'
16	Sleep Timer	f	f	00H to 08H
17	Auto Off	f	g	00H to 01H
18	Language	f	i	02H to 14H
19	ISM Method	j	p	See '19. ISM Method'
20	DPM Select	f	j	00H to 01H
21	Reset	f	k	00H to 03H
22	Tile Mode	d	d	See '22. Tile Mode'
23	Tile ID	d	i	See '23. Tile ID'
24	Natural Mode (in Tile Mode)	d	j	00H to 01H
25	OSD Menu	k	L	00H to 01H
26	Time elapsed	d	L	FFH
27	Product serial number	f	Y	FFH
28	SW Version	f	Z	FFH
29	Automatic Standby	m	N	00H to 01H

Transmission / Receiving Protocol

Transmission

[Command1][Command2][][Set ID][][Data][Cr]

- * [Command1] : Identifies between the factory setting and the user setting modes.
- * [Command2] : Controls monitor sets.
- * [Set ID] : Used for selecting a set you want to control. A unique set ID can be assigned to each set ranging from 1 to 255 (01H to FFH) in Setting on the OSD menu.
Selecting '00H' for set ID allows the simultaneous control of all connected monitor sets.
- * [Data] : Transmits command data.
- * [Cr] : Carriage Return. Corresponds to '0x0D' in ASCII code.
- * [] : White Space. Corresponds to '0x20' in ASCII code.

Acknowledgement

[a][][Set ID][][OK/NG][Data][x]

- * When the product receives data normally, it sends an acknowledgement (ACK) in the format above. At this time, if the data is Data Read Mode, it indicates present status data to read. If the data is Data Write Mode, it returns the data sent from your computer.
- * Note: Acknowledgement may not be received or receiving may be delayed until monitor booting is complete.
- * If a command is sent with Set ID '00' (=0x00), the data is reflected to all monitor sets and they do not send any acknowledgement (ACK).

01. Power (Command: k a)

* Controls switching the set on/off.

Transmission**[k][a][][Set ID][][Data][Cr]**Data 00: Power off
01: Power on**Acknowledgement****[a][][Set ID][][OK/NG][Data][x]**

* Shows the status of power on/off.

Transmission**[k][a][][Set ID][][FF][Cr]****Acknowledgement****[a][][Set ID][][OK][Data][x]**Data 00: Power off
01: Power on**02. Input Select (Command: x b)**

* Selects an input signal.

Transmission**[x][b][][Set ID][][Data][Cr]**Data 70: DVI-D (PC)
90: HDMI (DTV)

A0: HDMI (PC)

D0: Display Port (PC)

Acknowledgement**[b][][Set ID][][OK/NG][Data][x]**

* This feature may not be available depending on your model.

03. Ratio (Command: k c)

* Adjusts the aspect ratio.

Transmission**[k][c][][Set ID][][Data][Cr]**Data 02: Wide Screen (16:9)
09: Original
10: Cinema Zoom 1
11: Cinema Zoom 2
0A: 1:1 screen**Acknowledgement****[c][][Set ID][][OK/NG][Data][x]****04. Picture Mode (Command: d x)**

* Selects a picture mode.

Transmission**[d][x][][Set ID][][Data][Cr]**

DVI, DP, HDMI input in PC MODE

Data 00: Picture
01: Document
02: Game
05: Custom
06: Cinema

HDMI input in AV MODE

00: Vivid 1
01: Standard
02: Cinema
05: Custom
06: Vivid 2**Acknowledgement****[x][][Set ID][][OK/NG][Data][x]****05. Contrast (Command: k g)**

* Adjusts the screen contrast.

Transmission**[k][g][][Set ID][][Data][Cr]**

Data 00-64: Contrast 0-100

Acknowledgement**[g][][Set ID][][OK/NG][Data][x]****06. Brightness (Command: k h)**

* Adjusts the screen brightness.

Transmission**[k][h][][Set ID][][Data][Cr]**

Data 00-64: Brightness 0-100

Acknowledgement**[h][][Set ID][][OK/NG][Data][x]**

07. Sharpness (Command: k k)

* Adjusts the screen sharpness.

Transmission**[k][k][][Set ID][][Data][Cr]**

Data 00-0A: Sharpness 0-10

Acknowledgement**[k][][Set ID][][OK/NG][Data][x]****10. Volume (Command: k f)**

* Adjusts the volume (sound).

Transmission**[k][f][][Set ID][][Data][Cr]**

Data 00-64: Volume 0-100

Acknowledgement**[f][][Set ID][][OK/NG][Data][x]****08. Color Temp (Command: x u)**

* Adjusts the screen color temperature.

Transmission**[x][u][][Set ID][][Data][Cr]**Data 00: Cool
01: Standard
02: Warm
03: Custom**Acknowledgement****[u][][Set ID][][OK/NG][Data][x]****11. Clock 1 (year/month/day) (Command: f a)**

* Sets the Clock 1 (year/month/day) value.

Transmission**[f][a][][Set ID][][Data1][][Data2][][Data3][Cr]**Data1 0D-63: Year 2013-2099
Data2 01-0C: January-December
Data3 01-1F: 1st-31st

* Enter "fa [Set ID] ff" to view the Clock 1 settings.

Acknowledgement**[a][][Set ID][][OK/NG][Data1][Data2][Data3][x]****09. MUTE (Command: k e)**

* Mutes/unmutes the volume (sound).

Transmission**[k][e][][Set ID][][Data][Cr]**Data 00: Mute
01: Unmute**Acknowledgement****[e][][Set ID][][OK/NG][Data][x]****12. Clock 2 (hour/minute/second) (Command: f x)**

* Sets the Clock 2 (hour/minute/second) value.

Transmission**[f][x][][Set ID][][Data1][][Data2][][Data3][Cr]**Data1 00-17: 00-23 hours
Data2 00-3B: 00-59 minutes
Data3 00-3B: 00-59 seconds

* Enter "fx [Set ID] ff" to view the Clock 2 settings.

** This function is available only when Clock 1 is set.

Acknowledgement**[x][][Set ID][][OK/NG][Data1][Data2][Data3][x]**

13. Off Timer (repeat mode/time) (Command: f e)

* Sets Off Timer (repeat mode/time).

Transmission

[f][d][][Set ID][][Data1][][Data2][][Data3][Cr]

1. f1h to f4h (Read data)

Data1

F1: Reads the 1st Off Timer data

F2: Reads the 2nd Off Timer data

F3: Reads the 3rd Off Timer data

F4: Reads the 4th Off Timer data

Data2 FF

Data3 FF

* Checks Off Timer (repeat mode/hour/minute).

Transmission

[f][e][][Set ID][][Data][][f][f][][f][f][Cr]

Data f1-f4: First to fourth index number in the Off Timer list

Acknowledgement

[e][][Set ID][][OK/NG][Data1][Data2][Data3][Data4]

[X]

Data1 f1-f4: First to fourth index number in the Off Timer list

Data2 00: Repeat off

02. Daily

03: Mon. - Fri.

04: Mon. - Sat.

05: Sat. - Sun.

06. Every Sunday

07. Every Monday

08. Every Tuesday

09. Every Wednesday

0A. Every Thursday

0B. Every Friday

0C. Every Saturday

Data3 00-17: 00-23 hours

Data4 00-3B: 00-59 minutes

2. e1h-e4h (delete one index), e0h (delete all indexes)

Data1

E0: Erase all Off Timer settings

E1: Erase the first Off Timer setting

E2: Erase the second Off Timer setting

E3: Erase the third Off Timer setting

E4: Erase the fourth Off Timer setting

Data2 FF

Data3 FF

* To read or delete the Off Timer list you set, [Data2] [Data3] must be set to FFH.

3. 02h to 0Ch (Sets weekday for Off Timer)

Data1 00: Repeat off

02. Daily

03: Mon. - Fri.

04: Mon. - Sat.

05: Sat. - Sun.

06. Every Sunday

07. Every Monday

08. Every Tuesday

09. Every Wednesday

0A. Every Thursday

0B. Every Friday

0C. Every Saturday

Data2 00-17: 00-23 hours

Data3 00-3B: 00-59 minutes

** This function is available only when Clock 1 and Clock 2 are set.

Example 1: fe 01 f1 ff ff – Reads the 1st index data in Off Timer.

Example 2: fe 01 e1 ff ff – Erases the 1st index data in Off Timer.

Example3: fe 01 04 02 03 - Sets Off Timer to 02:03 for Monday-Saturday.

* This function is available only when Clock 1 (year/month/day) and Clock 2 (hour/minute/second) are set.

Acknowledgement

[e][][Set ID][][OK/NG][Data1][Data2][Data3][x]

14. On Timer (repeat mode/time) (Command: f d)

* Sets the On Timer (repeat mode/time).

Transmission

[f][d][][Set ID][][Data1][][Data2][][Data3][Cr]

Data1

1. f1h to f4h (Read data)

F1: Reads the first On Timer data

F2: Reads the second On Timer data

F3: Reads the third On Timer data

F4: Reads the fourth On Timer data

Data2 FF

Data3 FF

* Checks On Timer (repeat mode/hour/minute).

Transmission

[f][d][][Set ID][][Data][][f][f][][f][f][Cr]

Data f1-f4: First to fourth index number in the On Timer list

Acknowledgement

[d][][Set ID][][OK/NG][Data1][Data2][Data3][Data4]

[x]

Data1 f1-f4: First to fourth index number in the On Timer list

Data2 00: Repeat off

02. Daily

03: Mon. - Fri.

04: Mon. - Sat.

05: Sat. - Sun.

06. Every Sunday

07. Every Monday

08. Every Tuesday

09. Every Wednesday

0A. Every Thursday

0B. Every Friday

0C. Every Saturday

Data3 00-17: 00-23 hours

Data4 00-3B: 00-59 minutes

2. e1h-e4h (delete one index), e0h (delete all indexes)

Data1

E0: Erase all On Timer settings

E1: Erase the first On Timer setting

E2: Erase the second On Timer setting

E3: Erase the third On Timer setting

E4: Erase the fourth On Timer setting

Data2 FF

Data3 FF

3. 01h to 0Ch (sets weekday for On Timer)

Data1 00: Repeat off

02. Daily

03: Mon. - Fri.

04: Mon. - Sat.

05: Sat. - Sun.

06. Every Sunday

07. Every Monday

08. Every Tuesday

09. Every Wednesday

0A. Every Thursday

0B. Every Friday

0C. Every Saturday

Data2 00-17: 00-23 hours

Data3 00-3B: 00-59 minutes

* To read or delete an On Timer list you have set,

[Data2][Data3] must be set to FFH.

Example 1: fd 01 f1 ff ff - Reads the first index data in On Timer.

Example 2: fd 01 e1 ff ff - Erases the second index data in On Timer.

Example 3: fd 01 04 02 03 - Sets On Timer to 02:03 for Monday-Saturday.

* This function is available only when Clock 1 (year/month/day) and Clock 2 (hour/minute/second) are set.

* To ensure the On Timer schedule is set correctly, you must execute the On Timer Input command after executing this command.

Acknowledgement

[d][][Set ID][][OK/NG][Data1][Data2][Data3][x]

15. On Timer Input (Command: f u)

* Selects the video input for using On Timer.

Transmission

[f][u][][Set ID][][Data][Cr]

Data 70: DVI-D (PC)
90: HDMI (DTV)
A0: HDMI (PC)
D0: Display Port (PC)

* This function is only available when Clock 1, Clock 2 and On Timer (repeat mode/time) are set.

* To set the On Timer schedule correctly, the On Timer (repeat mode/time) command must be executed prior to this command.

Acknowledgement

[u][][Set ID][][OK/NG][Data][x]

* Checks the On Timer Input settings.

Transmission

[f][u][][Set ID][][Data][][f][f][Cr]

Data f1-f4: First to fourth index number in the On Timer Input list

Acknowledgement

[u][][Set ID][][OK/NG][Data1][Data2][x]

Data1 f1-f4: First to fourth index number in the On Timer Input list

Data2 70: DVI (PC)
90: HDMI (DTV)
A0: HDMI (PC)
D0: Display Port (PC)

16. Sleep Timer (Command: f f)

* Sets the sleep timer.

Transmission

[f][f][][Set ID][][Data][Cr]

Data 00: Off
01: 10 minutes
02: 20 minutes
03: 30 minutes
04: 60 minutes
05: 90 minutes
06: 120 minutes
07: 180 minutes
08: 240 minutes

Acknowledgement

[f][][Set ID][][OK/NG][Data][x]

17. Auto Off (Command: f g)

* Sets Auto Off.

Transmission

[f][g][][Set ID][][Data][Cr]

Data 00: Off (Auto Off disabled)
01: 15 minutes
(The set turns off if there is no signal for 15 minutes.)

Acknowledgement

[g][][Set ID][][OK/NG][Data][x]

18. Language (Command: f i)

* Sets the language for OSD.

Transmission

[f][i][][Set ID][][Data][Cr]

Data 02: German
03: English
04: Spanish (Europe)
05: Greek
06: French
07: Italian
0A: Portuguese
0B: Portuguese (Brazil)
0C: Russian
0D: Finnish
0E: Swedish
0F: Korean
10: Chinese
11: Japanese
13: Polish
14: Ukrainian

Acknowledgement

[i][][Set ID][][OK/NG][Data][x]

19. ISM Method (Command: j p)

* Selects an ISM Method option.

Transmission

[j][p][][Set ID][][Data][Cr]

Data 02: On

08: Off

Acknowledgement

[p][][Set ID][][OK/NG][Data][x]

20. DPM Select (Command: f j)

* Sets the DPM mode.

Transmission

[f][j][][Set ID][][Data][Cr]

Data 00: Off

01: On

Acknowledgement

[j][][Set ID][][OK/NG][Data][x]

21. Reset (Command: f k)

* Returns to the factory settings.

Transmission

[f][k][][Set ID][][Data][Cr]

Data 02: Factory Reset

Acknowledgement

[k][][Set ID][][OK/NG][Data][x]

22. Tile Mode (Command: d d)

* Sets the Tile Mode.

Transmission

[d][d][][Set ID][][Data][Cr]

Data The first byte - Tile column

The second byte - Tile row

Data	Description
00	Tile Mode disabled
12	1 x 2 mode (columns x lows)
21	2 X 1 mode
22	2 X 2 mode
31	3 X 1 mode
32	3 X 2 mode
41	4 X 1 mode
42	4 X 2 mode
51	5 X 1 mode
52	5 X 2 mode

Acknowledgement

[d][][Set ID][][OK/NG][Data][x]

23. Tile ID (Command: d i)

* Sets the Tile ID value of the product.

Transmission

[d][i][][Set ID][][Data][Cr]

Data 01-a: Tile ID 1-10

FF: Check Tile ID

** The Data value must not exceed the column x row value.

Acknowledgement

[i][][Set ID][][OK/NG][Data][x]

24. Natural Mode (in Tile mode) (Command: d j)

* Areas corresponding to the gap between each tile are removed to give the screen image a more natural look.

This function is only available when Tile Mode is enabled.

Transmission

```
[d][j][ ][Set ID][ ][Data][Cr]
```

Data 00: Natural Mode off

01: Natural Mode on

Acknowledgement

```
[j][ ][Set ID][ ][OK/NG][Data][x]
```

25. OSD Menu (Command: k l)

* Turns the OSD menu on/off.

Transmission

```
[k][l][ ][Set ID][ ][Data][Cr]
```

Data 00: OSD off

01: OSD on

Acknowledgement

```
[l][ ][Set ID][ ][OK/NG][Data][x]
```

26. Time elapsed (Command: d l)

* Checks the use time of the product.

Transmission

```
[d][l][ ][Set ID][ ][Data][Cr]
```

Data FF: Read status

Acknowledgement

```
[l][ ][Set ID][ ][OK/NG][Data][x]
```

* The data value received is shown in hexadecimal.

27. Serial No. Check (Command: f y)

* Checks the serial number of the product.

Transmission

```
[f][y][ ][Set ID][ ][Data][Cr]
```

Data FF: Check product serial number

Acknowledgement

```
[y][ ][Set ID][ ][OK/NG][Data][x]
```

* Data is ASCII code.

28. SW Version (Command: f z)

* Checks the software version of the product.

Transmission

```
[f][z][ ][Set ID][ ][Data][Cr]
```

Data FF: Check software version

Acknowledgement

```
[z][ ][Set ID][ ][OK/NG][Data][x]
```

* The data value received is shown in hexadecimal.

29. Automatic Standby (Command: m n)

Enables the Automatic Standby function (the set turns off after 4 hours).

Transmission

```
[m][n][ ][Set ID][ ][Data][Cr]
```

Data

00: Off

01: On

Acknowledgement

```
[n][ ][Set ID][ ][OK/NG][Data][x]
```



Make sure to read the Safety Precautions before using the product.
Keep the Owner's Manual(CD) in an accessible place for future reference.
The model and serial number of the SET is located on the back and one side of the SET.
Record it below should you ever need service.

MODEL _____

SERIAL _____

To obtain the source code under GPL, LGPL, MPL and other open source licenses, that is contained in this product, please visit <http://opensource.lge.com>.

In addition to the source code, all referred license terms, warranty disclaimers and copyright notices are available for download. LG Electronics will also provide open source code to you on CD-ROM for a charge covering the cost of performing such distribution (such as the cost of media, shipping and handling) upon email request to opensource@lge.com. This offer is valid for three (3) years from the date on which you purchased the product.

Temporary noise is normal when powering ON or OFF this device.