



**LG**

Life's Good

OWNER'S MANUAL

# MONITOR SIGNAGE

Please read this manual carefully before operating the your set and retain it for future reference.

MONITOR SIGNAGE MODELS

84WT70PS

# TABLE OF CONTENTS

## 4 LICENSES

---

## 5 ASSEMBLING AND PREPARING

---

- 5 Accessories
- 6 Optional Accessories
- 7 Parts and Buttons
- 9 Using the Mounting Cable Tie
- 9 Connecting the Eye-Bolt Bracket
- 10 Connecting the Pentray Assy
- 11 Connecting the Media Player
- 12 Mounting on a Wall

## 14 REMOTE CONTROL

---

- 16 Change Device Name
- 16 SimpLink Setting

## 17 USING THE MONITOR

---

- 17 Connecting to a PC
- 18 - RGB Connection
- 18 - DVI-D Connection
- 19 - HDMI Connection
- 19 - Display Port Connection
- 20 - TOUCH USB Cable Connection
- 21 - Using the Input List

## 22 ENTERTAINMENT

---

- 22 - Connecting to a Wired Network
- 23 - Network Status
- 24 - Connecting USB Storage Devices
- 26 - Using My Media
- 28 - Playing Video
- 31 - Viewing Photos
- 32 - Listening to Music

## 33 CUSTOMIZING SETTINGS

---

- 33 - PICTURE Settings
- 37 Using the Additional Options
- 37 - Adjusting Aspect Ratio
- 39 - SOUND Settings
- 40 - TIME Settings
- 41 - OPTION Settings
- 43 - NETWORK Settings
- 43 - SUPPORT Settings

## 44 MAKING CONNECTIONS

---

- 45 External Device Connection
- 45 - HDMI Connection
- 46 - AV (CVBS) Connection
- 47 Connecting to a USB
- 47 Connecting to the LAN
- 48 Daisy Chain Monitors

## 49 USING THE TOUCH SCREEN

---

- 49 To Use the Touch Screen on Windows 7
- 49 Gestures and Settings on Windows 7
- 50 Precaution When Using the Touch Screen
- 51 LG Touch Screen Software
- 51 - Specifications
- 51 - Precaution When Using LG Touch Screen Software

## **52 TROUBLESHOOTING**

---

## **57 SPECIFICATIONS**

---

## **62 IR CODES**

---

## **63 CONTROLLING THE MULTIPLE PRODUCT**

---

- 63 Connecting the Cable
- 63 RS-232C Configurations
- 63 Communication Parameter
- 64 Command Reference List
- 66 Transmission/ Receiving protocol

# LICENSES

Supported licenses may differ by model. For more information of the licenses, visit [www.lg.com](http://www.lg.com).



The terms HDMI and HDMI High-Definition Multimedia Interface, and the HDMI logo are trademarks or registered trademarks of HDMI Licensing LLC in the United States and other countries.



**ABOUT DIVX VIDEO:** DivX® is a digital video format created by DivX, LLC, a subsidiary of Rovi Corporation. This is an official DivX Certified® device that plays DivX video. Visit [divx.com](http://divx.com) for more information and software tools to convert your files into DivX videos.

**ABOUT DIVX VIDEO-ON-DEMAND:** This DivX Certified® device must be registered in order to play purchased DivX Video-on-Demand (VOD) movies. To obtain your registration code, locate the DivX VOD section in your device setup menu. Go to [vod.divx.com](http://vod.divx.com) for more information on how to complete your registration.

DivX Certified® to play DivX® video up to HD 1080p, including premium content.

DivX®, DivX Certified® and associated logos are trademarks of Rovi Corporation or its subsidiaries and are used under license.

Covered by one or more of the following U.S. patents: 7,295,673; 7,460,668; 7,515,710; 7,519,274



Manufactured under license from Dolby Laboratories. Dolby and the double-D symbol are trademarks of Dolby Laboratories.

## NOTE

- The warranty will not cover any damages caused by using the product in an excessively dusty environment.
- Avoid using the product in a high temperature and high humidity area. Moving the monitor from a environment like this to an air conditioned area may cause moisture formation inside the glass. This moisture will be dissipate over time, which may vary depending on the operating environment.

# ASSEMBLING AND PREPARING

## Accessories

Check your product box for the following items. If there are any missing accessories, contact the local dealer where you purchased your product. The illustrations in this manual may differ from the actual product and accessories.

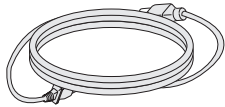

**Power Cord**

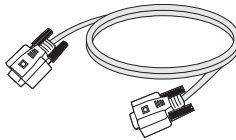

**D-sub 15 pin signal cable**

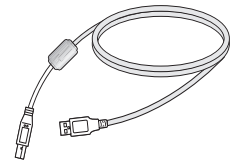

**USB Cable**

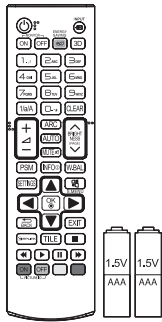

**Remote control and  
Batteries**

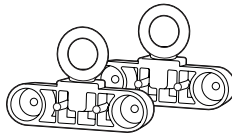

**Eye-Bolt Bracket (2 EA)**



**M4 x L12 Screw (6 EA)**



**CD (Owner's Manual/ LG  
Touch Screen SW) / Cards**



**Pen Tray**

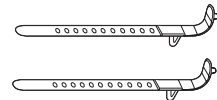

**Mounting Cable Tie (2 EA)**



### CAUTION

- Do not use any pirated items to ensure the safety and product life span.
- Any damages or injuries by using pirated items are not covered by the warranty.



### NOTE

- The accessories supplied with your product may vary depending on the model.
- Product specifications or contents in this manual may be changed without prior notice due to upgrade of product functions.

## Optional Accessories

Without prior notice, optional accessories are subject to change to improve the performance of the product, and new accessories may be added. The illustrations in this manual may differ from the actual product and accessories.

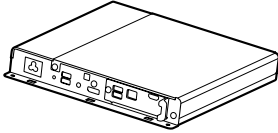

**Media Player**



**Screws**



**CD (Owner's Manual) / Card**

**Media Player Kit**



**NOTE**

- Optional accessories are not included for all models.

## Parts and Buttons

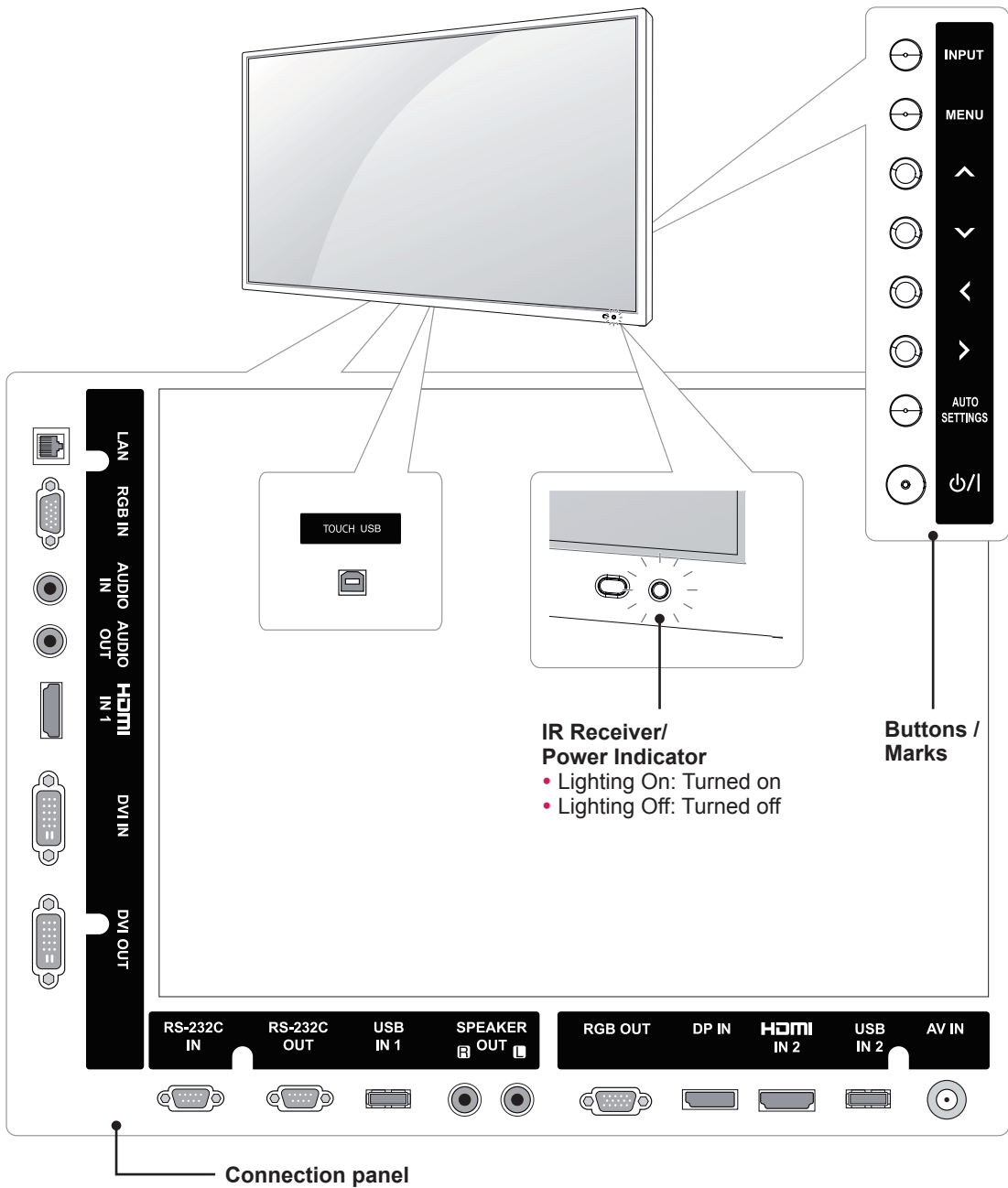

### NOTE

- You can set the Power indicator to on or off by selecting **OPTION** in the main menu.

Screen Marks	Description
INPUT	Changes the input source.
MENU	Accesses the main menus, or saves your input and exits the menus.
^v	Moves the selection up and down.
<>	Adjusts the volume level.
AUTO/SET	Displays the current signal and mode. Press this button to adjust the screen automatically (available only in RGB mode)
⏻ / I	Turns the power on or off.
IR Receiver	This is where the unit receives signals from the remote control.
Power Indicator	This Indicator lights up red when the display operates normally (on mode). If the display In sleep mode (In Power Saving mode), this indicator color changes to amber.



## Using the Mounting Cable Tie

Insert the two cable ties into the bottom hole on the back of the set as shown in the figure to organize cables.

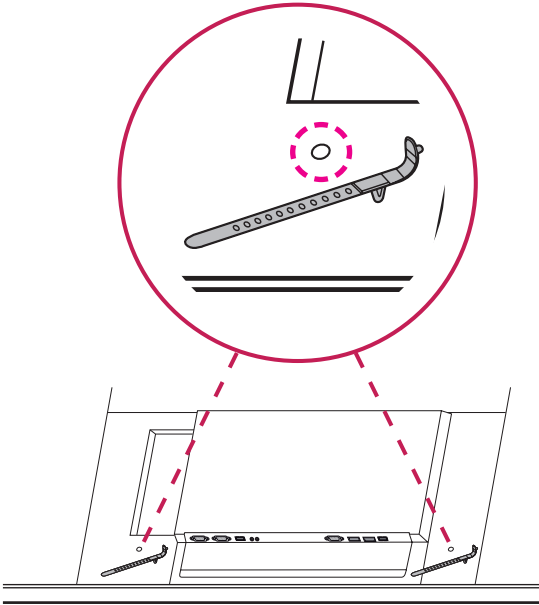

## Connecting the Eye-Bolt Bracket

The eye-bolt bracket is designed to be used to lift the set up.

Attach the bracket to the product using the two screws provided.

### Installing in Landscape Position

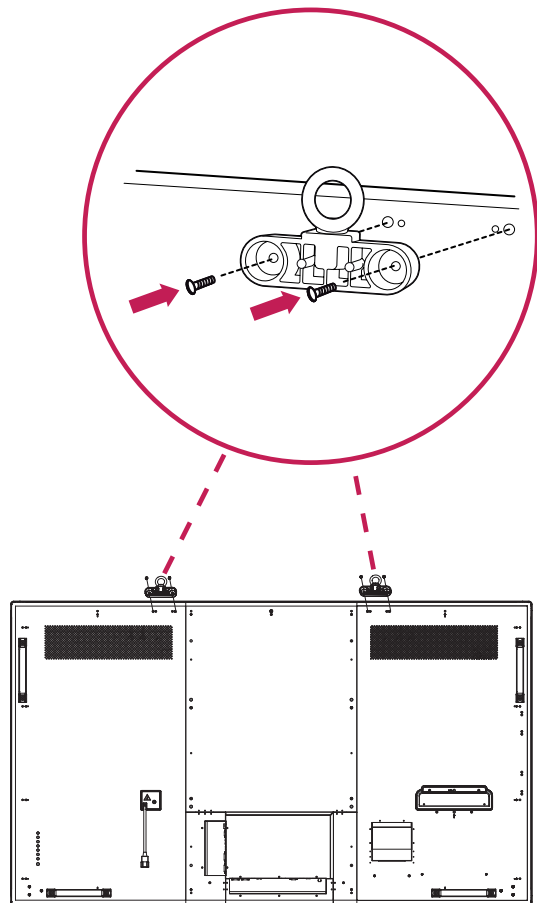

## Connecting the Pentray Assy

Use the screws provided to attach the Pentray Assy.

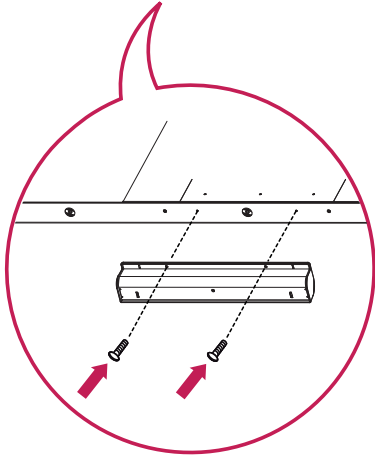
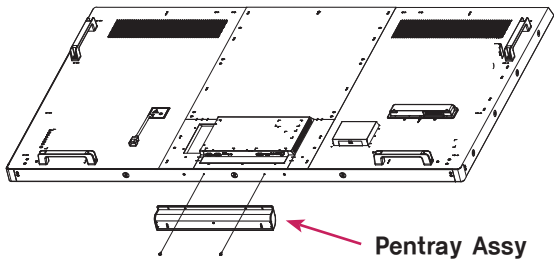

## Connecting the Media Player

- 1 Place a soft cloth on the table and put the set with the screen facing downward. Remove the handle at the bottom of the section where the Media Player is mounted on the set.

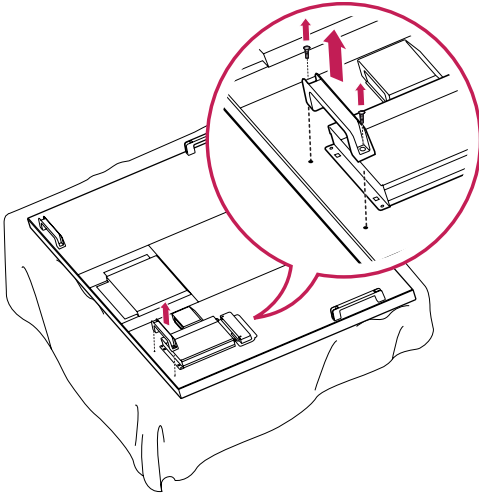

- 2 To mount the Media Player, push it into the special compartment located on the back of the monitor.

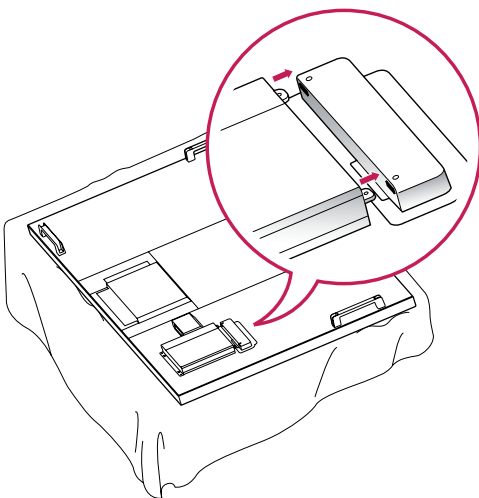

- 3 Attach the Media Player using the four provided screws.

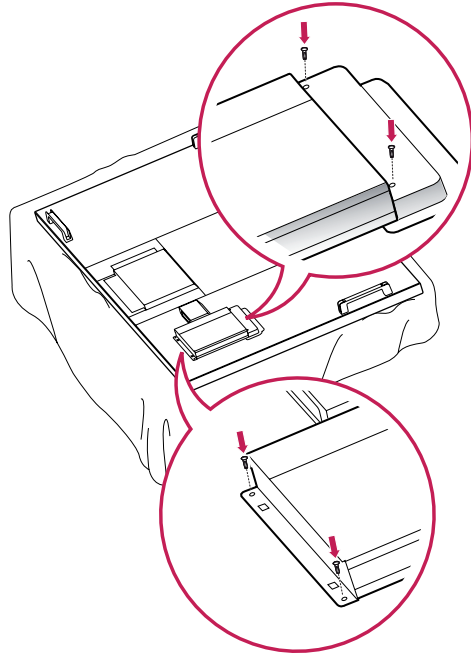

### ! NOTE

- Use the screws provided with the product (diameter 3.0 mm x pitch 0.5 mm x length 6.0 mm).

## Mounting on a Wall

For proper ventilation, allow a clearance of 10 cm on each side and from the wall. Detailed installation instructions are available from your dealer, see the optional Tilt Wall Mounting Bracket Installation and Setup Guide.

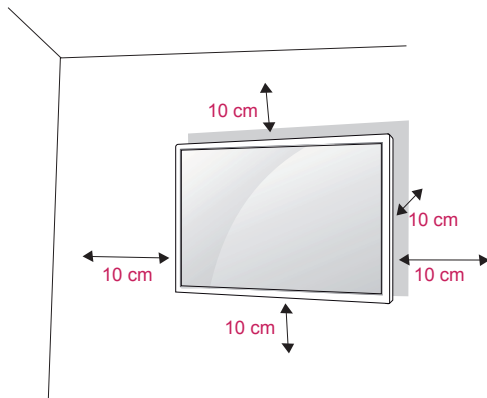

If you intend to mount the monitor to a wall, attach a Wall mounting interface (optional parts) to the back of the set.

When you install the monitor using a wall mounting interface (optional parts), attach it carefully so it will not fall.

- 1 Please, use a wall mount and screws in accordance with VESA Standards.
- 2 If you use screws longer than standard, the monitor might be damaged internally.
- 3 If you use improper screws, the product might be damaged and drop from mounted position. In this case, LG Electronics is not responsible for damage.
- 4 Please use VESA standard as below.
  - 785mm or greater
  - \* Fastening screw: Diameter 8.0 mm x Pitch 1.25 mm x Length 16 mm



### CAUTION

- Disconnect the power before installing or moving the monitor. Otherwise electric shock may occur.
- If you install the monitor on a ceiling or slanted wall, it may fall and result in severe injury.
- Use an authorized LG wall mount and contact the local dealer or qualified personnel.
- Do not over tighten the screws as this may cause damage to the Monitor and void your warranty.
- Use screws and wall mounts that meet the VESA standard. Any damages or injuries by misuse or using an improper accessory are not covered by the warranty.
- To prevent injury, this apparatus must be securely attached to the wall in accordance with the installation instructions. (This only pertains to Australia and New Zealand.)



### NOTE

- The wall mount kit includes an installation manual and necessary parts.
- The wall mount bracket is optional. You can obtain additional accessories from your local dealer.
- The length of screws may differ depending on the wall mount. Be sure to use the proper length.
- For more information, refer to the instructions supplied with the wall mount.

**Securing the product to a wall (optional)**

(Depending on model)

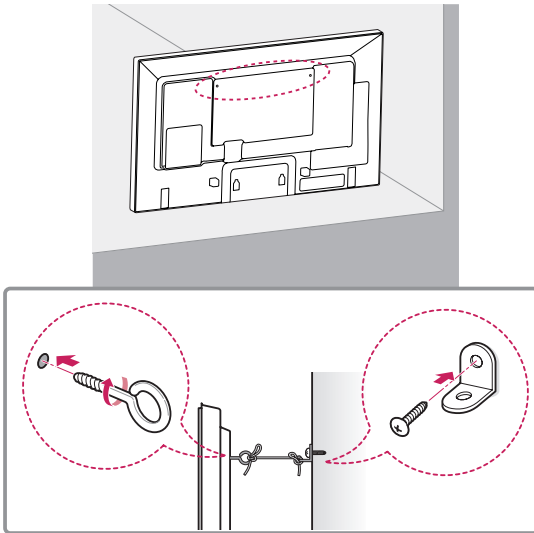

- 1 Insert and tighten the eye-bolts, or product brackets and bolts on the back of the product.  
- If there are bolts inserted at the eye-bolts position, remove the bolts first.
- 2 Mount the wall brackets with the bolts to the wall.  
Match the location of the wall bracket and the eye-bolts on the rear of the product.
- 3 Connect the eye-bolts and wall brackets tightly with a sturdy rope.  
Make sure to keep the rope horizontal with the flat surface.

**CAUTION**

- Make sure that children do not climb on or hang on the product.

**NOTE**

- Use a platform or cabinet that is strong and large enough to support the product securely.
- Brackets, bolts and ropes are optional. You can obtain additional accessories from your local dealer.

**WARNING**

- If a product is not positioned in a sufficiently stable location, it can be potentially hazardous due to falling. Many injuries, particularly to children, can be avoided by taking simple precautions such as:
  - » Using cabinets or stands recommended by the manufacturer of the product.
  - » Only using furniture that can safely support the product.
  - » Ensuring the product is not overhanging the edge of the supporting furniture.
  - » Not placing the product on tall furniture (for example, cupboards or bookcases) without anchoring both the furniture and the product to a suitable support.
  - » Not standing the product on cloth or other materials placed between the product and supporting furniture.
  - » Educating children about the dangers of climbing on furniture to reach the product or its controls.

# REMOTE CONTROL

The descriptions in this manual are based on the buttons of the remote control. Please read this manual carefully and use the Monitor correctly.

To replace batteries, open the battery cover, replace batteries (1.5 V AAA) matching ⊕ and ⊖ ends to the label inside the compartment, and close the battery cover.

To remove the batteries, perform the installation actions in reverse.

**CAUTION**

- Do not mix old and new batteries, as this may damage the remote control.
- Make sure to point the remote control at the remote control sensor on the Monitor.

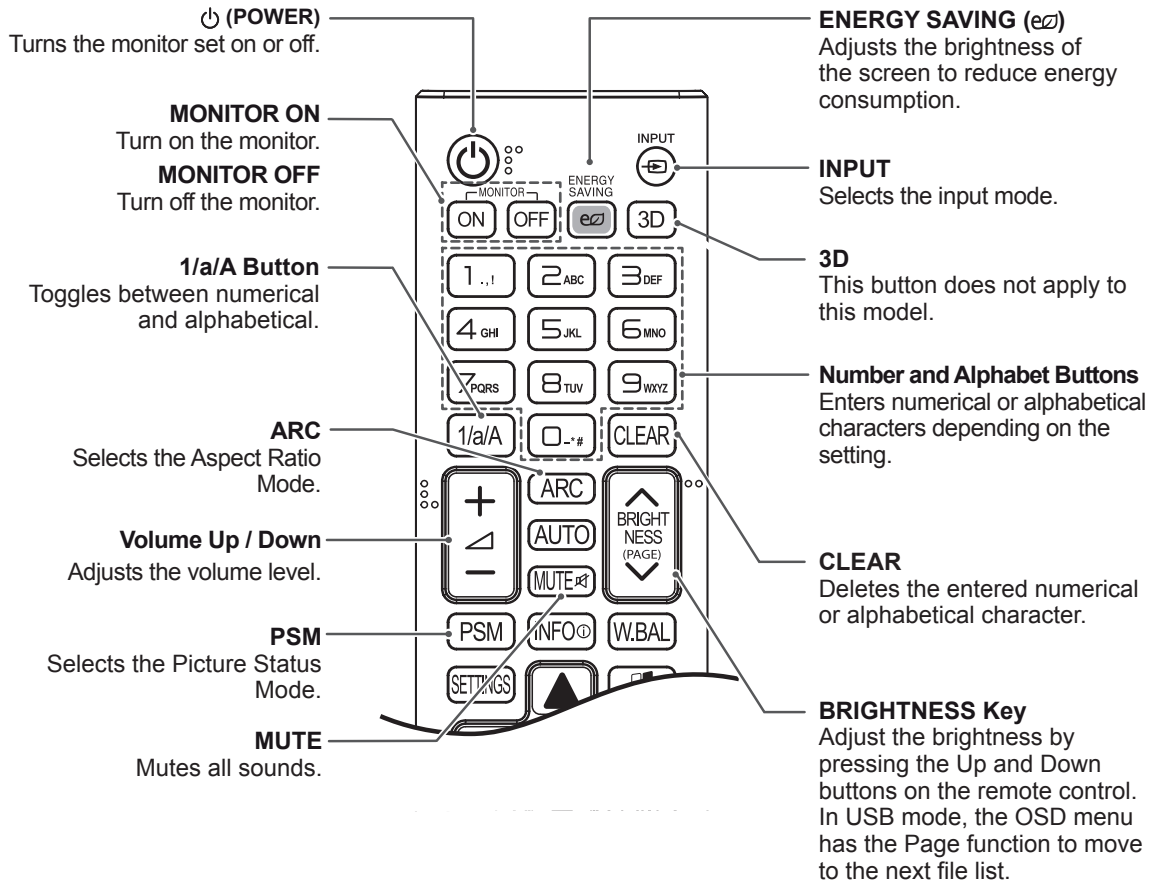
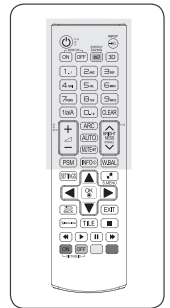
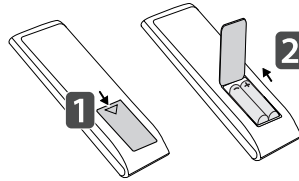

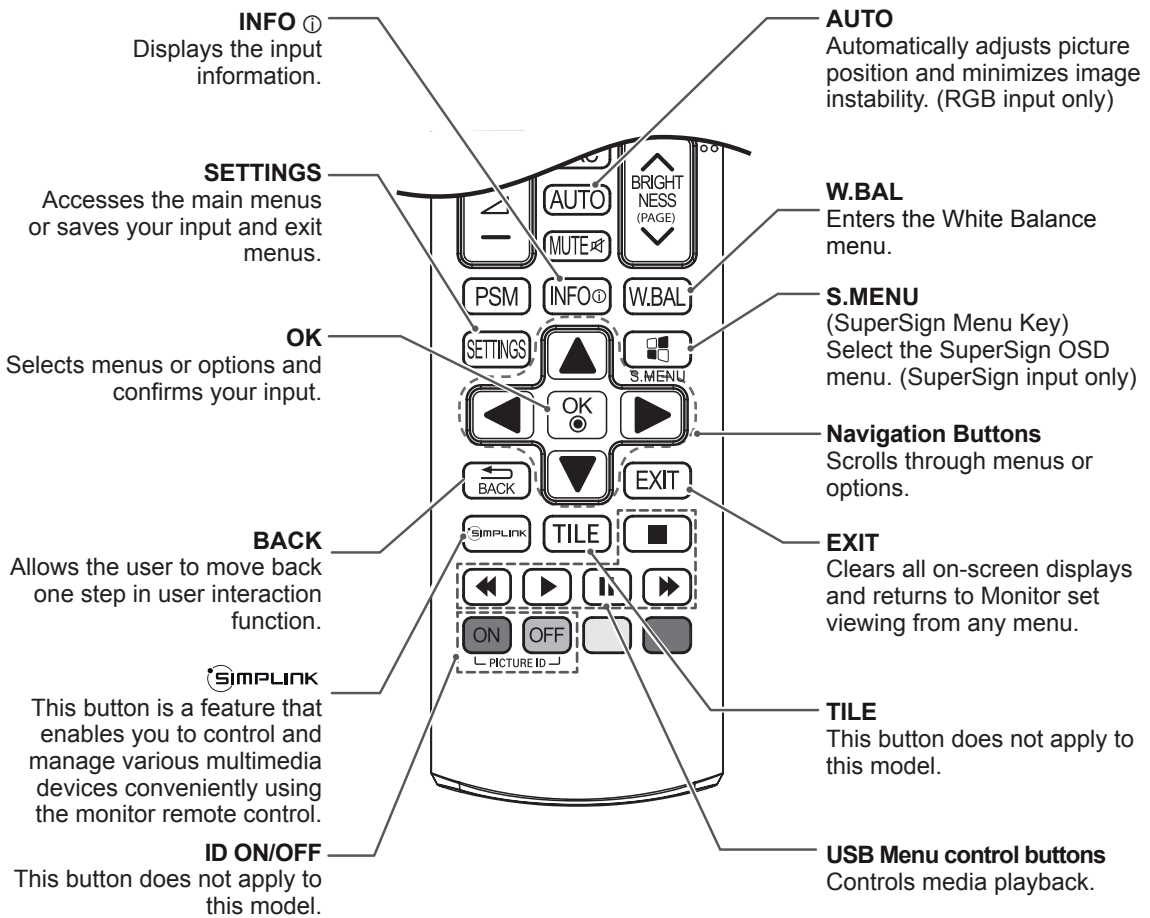
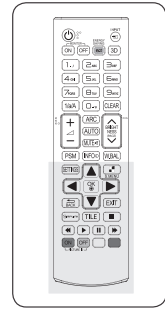

## Change Device Name

You can edit the name of the external device connected to the input port to display which device is connected to the port.

- 1 Press **INPUT** to access **Input List**.

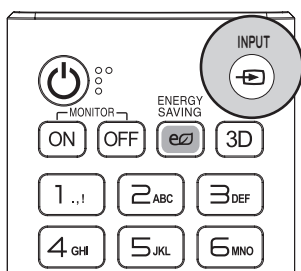

- 2 In the **Input List** screen, press the **ID ON** (red) on the remote control.

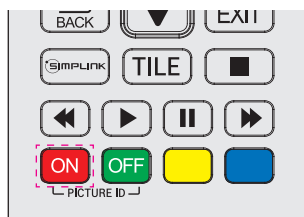

- 3 You can select any option for **Input Label** except USB.

## SimpLink Setting

SimpLink allows you to control various multimedia devices to enjoy the multimedia simply by using the remote control through the SimpLink menu.

- 1 Press **INPUT** to access **Input List**.

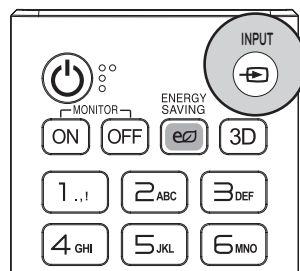

- 2 In the **Input List** screen, press the **ID OFF** (green) on the remote control.

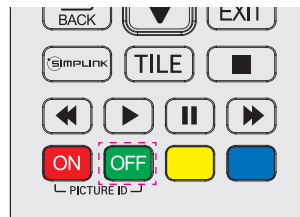

### NOTE

- External inputs supported: **AV, RGB-PC, HDMI1, HDMI2, DVI-D, Display Port** and **SuperSign**
- Input labels available: **Blu-ray, DVD, VCR, Home theater, AV Receiver, Set-top Box, Cable Box, Satellite, IPTV, TV, Smart Box, Game, PC, Laptop Computer, Smart phone, Camera, and Camcorder.**
- The set **Input Label** is displayed on the **Input List**, or when switching the input.
- If DTV/PC compatible signals are output, the screen settings change according to the **Input Label** setting. If Input Label is set to PC, the screen's aspect ratio is automatically set to Just Scan.



# USING THE MONITOR

## Connecting to a PC

Your Monitor supports the Plug & Play\* feature.

\* Plug & Play: This is the function that allows a PC to use the monitor without installing a driver.

### ! NOTE

- It is recommended you use an HDMI connection for the best image quality.
- Use a shielded signal interface cable, such as D-sub 15-pin signal cable and DVI cable, with a ferrite core to maintain standard compliance for the product.
- If you turn the Monitor on when the set is cold, the screen may flicker. This is normal.
- Some red, green, or blue spots may appear on the screen. This is normal.
- For some graphic cards, the screen may not display properly when you use dual monitors.



### CAUTION

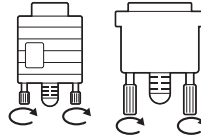

- Connect the signal input cable and tighten it by turning the screws clockwise.
- Do not press the screen with your finger for a long time as this may result in temporary distortion on the screen.
- Avoid displaying a fixed image on the screen for a long period of time to prevent image burn. Use a screensaver if possible.

## RGB Connection

Transmits an analog video signal from your PC to the Monitor. Connect the PC and the Monitor set with the 15 pin signal cable as shown in the following illustrations.

Select RGB input source on the monitor.

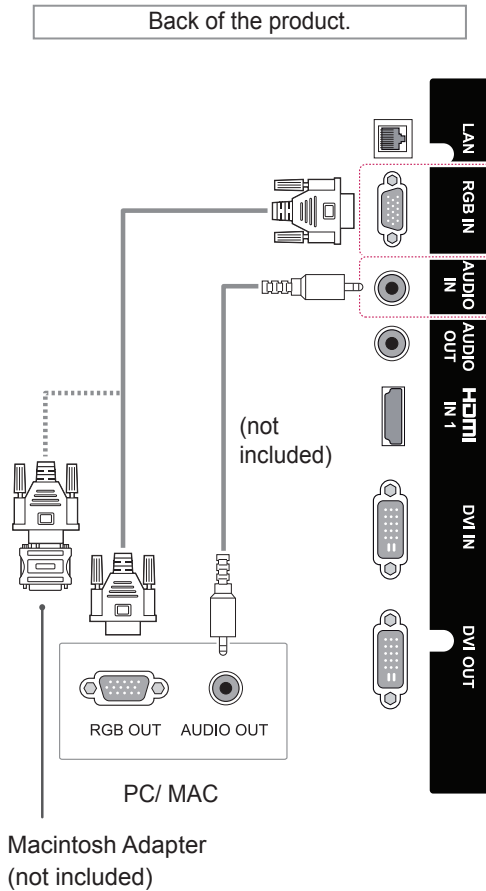

## DVI-D Connection

Transmits a digital video signal from your PC to the Monitor. Connect the PC and the Monitor with a DVI cable as shown in the following illustrations.

Select DVI-D input source on the monitor.

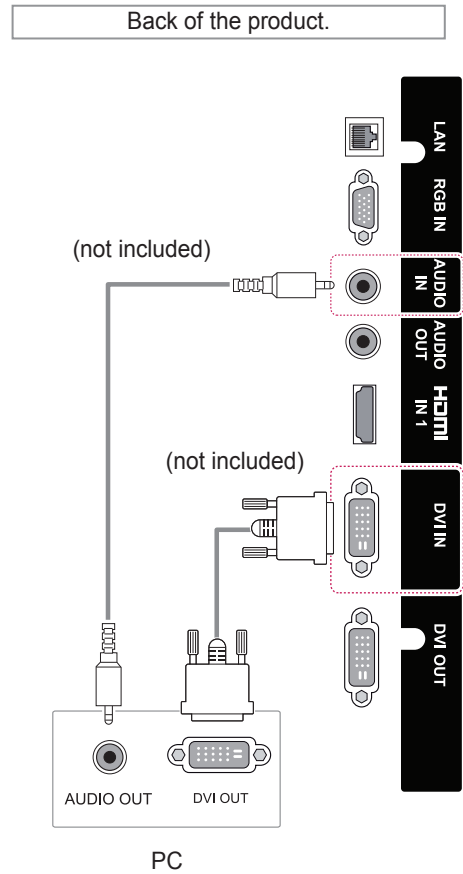

### NOTE



- Use the standard Macintosh adapter since an incompatible adapter is available in the market. (Different signaling system)
- Apple computers may require an adapter to connect to this monitor. Call or visit their web site for more information.

## HDMI Connection

Transmits the digital video and audio signals from your PC to the Monitor. Connect the PC and the Monitor with an HDMI cable as shown in the following illustration.

Select HDMI input source.

## Display Port Connection

Transmits the digital video and audio signals from your PC to the Monitor. Connect the PC and the Monitor with a Display Port cable as shown in the following illustrations.

Select Display Port input source.

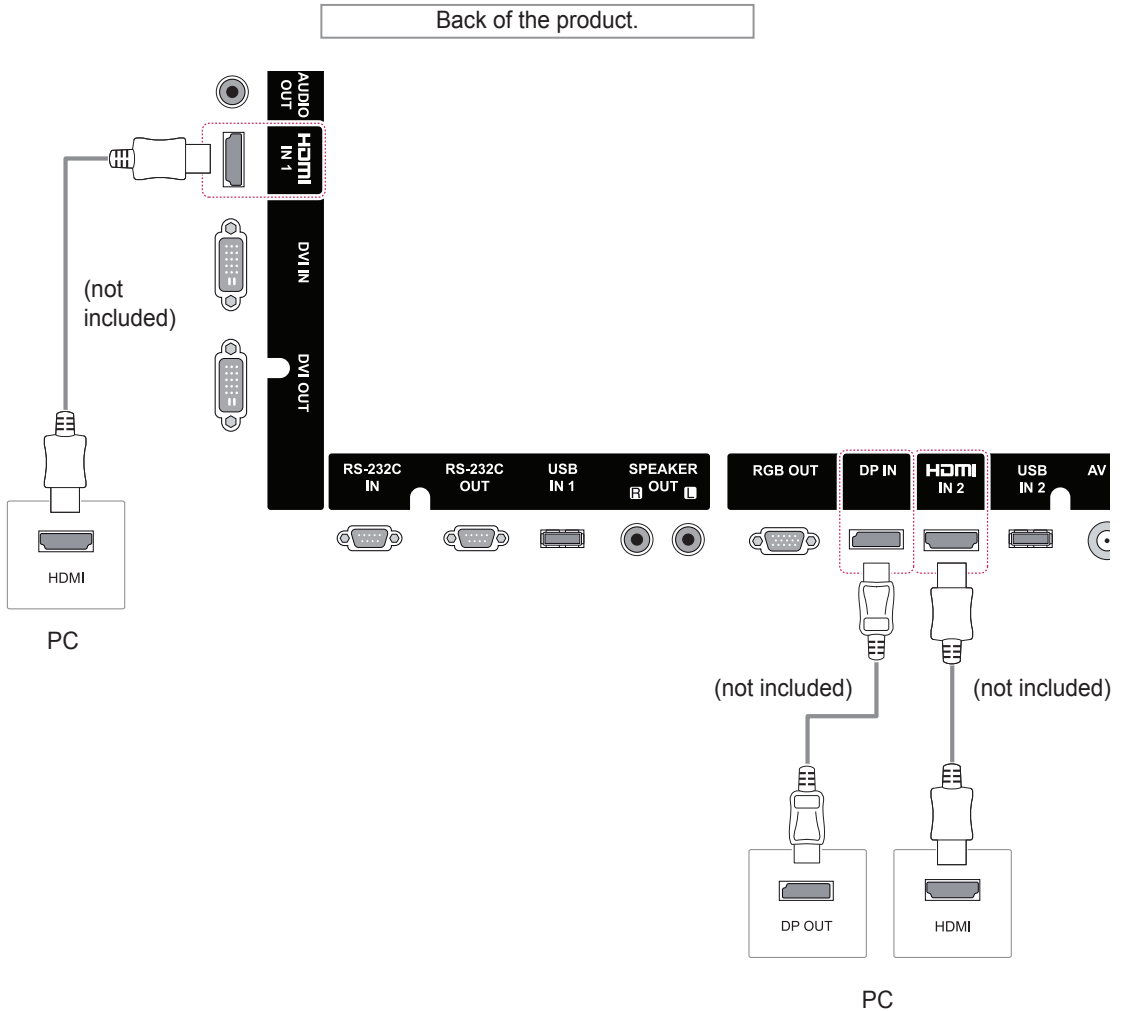

### NOTE

- Use a High Speed HDMI™ Cable.
- Please check the PC environment if you cannot hear audio in HDMI mode. Some PCs require you to manually change the default audio output to HDMI.
- If you want to use HDMI PC mode, you must set PC/DTV to PC mode.
- When HDMI PC is used, a compatibility problem might occur.

### NOTE

- It is recommended to use the following specifications to play 3840 x 2160 video seamlessly in HDMI or DP modes.
  - » Recommended PC specifications - CPU: Intel core i7 or higher, graphic card: NVIDIA GTX TITAN or higher, AMD HD7000 series or higher.
  - » Recommended video - For H.264, 140 Mbps or lower data transmission rate.

## TOUCH USB Cable Connection

Plug a USB cable into a TOUCH USB port on the back of the monitor.

Back of the product.

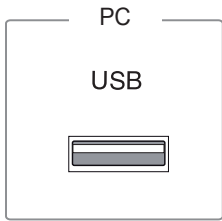

TOUCH USB



## Using the Input List

- 1 Press **INPUT** to access the **INPUT LIST**.

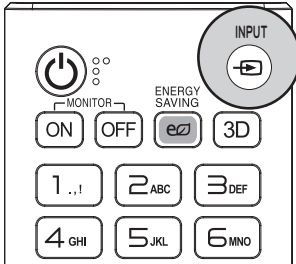

- 2 Press the Navigation buttons to scroll to one of the input sources and press **OK**.

Input source	Description
<b>AV</b>	Watch video from a VCR or other external devices.
<b>RGB-PC</b>	View a PC display on the screen.
<b>HDMI1</b>	Watch contents in a PC, DVD of Digital set-top box other high definition devices.
<b>HDMI2</b>	Watch contents in a PC, DVD of Digital set-top box other high definition devices.
<b>Display Port</b>	Watch contents in a PC, DVD of Digital set-top box other high definition devices.
<b>DVI-D</b>	View a PC display on the screen.
<b>SuperSign</b>	Views the Media Player display on the screen.

# ENTERTAINMENT

## Connecting to a Wired Network

(Depending on model)

Connect the display to a local area network (LAN) via the LAN port as shown in the following illustration and set up the network settings.

This monitor only supports a wired network connection.

After making a physical connection, a small number of home networks may require the display network settings to be adjusted. For most home networks, the display will connect to automatically without any adjustments.

For detail information, contact your internet provider or router manual.

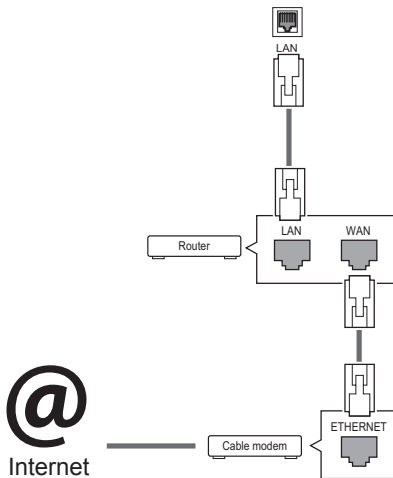

Follow the steps below to set up the network settings. (Even if your display is already connected automatically, running setup again will not harm anything.)

- 1 Press **SETTINGS** to access the main menus.
- 2 Press the Navigation buttons to scroll to **NETWORK** and press **OK**.
- 3 Press the Navigation buttons to scroll to **Network Connection** and press **OK**.
- 4 Select **Set Expert**.
- 5 Select **Manual Mode** or **Auto Input**.

If you select **Manual Mode**, press the Navigation and Number buttons. IP addresses will need to be input manually.

- **Auto Input**: Select this if there is a DHCP server (router) on the Local Area Network (LAN) via wired connection, the display will be automatically allocated an IP address. If you're using a broadband router or broadband modem that has a Dynamic Host Configuration Protocol (DHCP) server function, the IP address will be automatically determined.

- 6 When you are finished, press **EXIT**.

### ! CAUTION

- Do not connect a modular phone cable to the LAN port.
- Since there are various connection methods, please follow the specifications of your telecommunication carrier or internet service provider.

### ! CAUTION

- Network setting menu will not be available until the display is connected to physical network.
- Since there are various connection methods, please follow the specifications of your telecommunication carrier or internet service provider.

 **NOTE**

- If you want to access the Internet directly on your display, the internet connection should always be on.
- If you cannot access the Internet, check the network conditions from a PC on your network.
- When you use **Network Setting**, check the LAN cable or check if DHCP in the router is turned on.
- If you do not complete the network settings, the network may not work properly.

**Tips for Network setting**

- Use a standard LAN cable with this display. Cat5 or better with a RJ45 connector.
- Many network connection problems during set up can often be fixed by re-setting the router or modem. After connecting the display to the home network, quickly power off and/or disconnect the power cable of the home network router or cable modem. Then power on and/or connect the power cable again.
- Depending on the internet service provider (ISP), the number of devices that can receive internet service may be limited by the applicable terms of service. For details, contact your ISP.
- LG is not responsible for any malfunction of the display and/or the internet connection feature due to communication errors/malfunctions associated with your internet connection, or other connected equipment.
- LG is not responsible for problems within your internet connection.
- You may experience undesired results if the network connection speed does not meet the requirements of the content being accessed.
- Some internet connection operations may not be possible due to certain restrictions set by the Internet service provider (ISP) supplying your Internet connection.
- Any fees charged by an ISP including, without limitation, connection charges are your responsibility.

- A 10 Base-T or 100 Base-TX LAN port is required when using a wired connection to this display. If your internet service does not allow for such a connection, you will not be able to connect the display.
- A DSL modem is required to use DSL service and a cable modem is required to use cable modem service. Depending on the access method of and subscriber agreement with your ISP, you may not be able to use the internet connection feature contained in this display or you may be limited to the number of devices you can connect at the same time. (If your ISP limits sub-scription to one device, this display may not be allowed to connect when a PC is already connected.)
- The use of a Router may not be allowed or its usage may be limited depending on the policies and restrictions of your ISP. For details, contact your ISP directly.

**Network Status**

- 1 Press **SETTINGS** to access the main menus.
- 2 Press the Navigation buttons to scroll to **NETWORK** and press **OK**.
- 3 Press the Navigation buttons to select **Network Status**.
- 4 Press **OK** to check the network status.
- 5 When you are finished, press **EXIT**.

## Connecting USB Storage Devices

Connect a USB storage device (external HDD, USB memory) to the USB port of Monitor to enjoy the content files stored in the USB device on your Monitor.

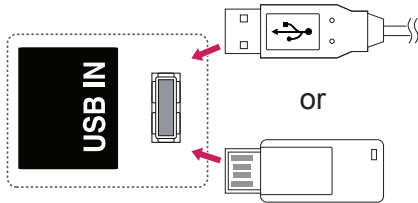

### CAUTION

- Back up your files saved on a USB storage device frequently, as you may lose or damage the files and this may be not covered by the warranty.

### Tips for using USB storage devices

- Only a USB storage device is recognizable.
- If the USB storage device is connected through a USB hub, the device is not recognizable.
- A USB storage device using an automatic recognition program may not be recognized.
- A USB storage device which uses its own driver will not be recognized.
- The recognition speed of a USB storage device may depend on each device.
- Please do not turn off the display or unplug the USB device when the connected USB storage device is working. When such a device is suddenly separated or unplugged, the stored files or the USB storage device may be damaged.
- Please do not connect the USB storage device which was artificially maneuvered on the PC. The device may cause the product to malfunction. Only use a USB storage device which has normal music files, image files or movie files.
- Please use only a USB storage device which was formatted as a FAT32 file system or NTFS file system by the Windows operating system. In case of a storage device formatted with a different utility program which is not supported by Windows, it may not be recognized.
- Please connect power to a USB storage device (over 0.5 A) which requires an external power supply. If not, the device may not be recognized.
- Please connect a USB storage device with the cable included by the device maker.
- Some USB storage devices may not be supported or operate smoothly.
- File alignment method of USB storage devices is similar to Window XP and the Monitor can recognize up to 100 English characters.
- Be sure to back up important files since data stored on a USB memory device may be damaged. We will not be responsible for any data loss.



- If the USB HDD does not have an external power source, the USB device may not be detected. So be sure to connect the external power source.
  - Please use a power adaptor for an external power source.
- If your USB memory device has multiple partitions, or if you use a USB multi-card reader, you can use up to 4 partitions or USB memory devices.
- If a USB memory device is connected to a USB multi-card reader, its volume data may not be detected.
- If the USB memory device does not work properly, disconnect and reconnect it.
- How fast a USB memory device is detected differs from device to device.
- If the USB is connected in Standby Mode, that drive will automatically be loaded when the display is turned on.
- The recommended capacity is 1 TB or less for a USB external hard disk and 32 GB or less for USB memory.
- Any device with more than the recommended capacity may not work properly.
- If a USB external hard disk with a Energy Saving function does not work, turn the hard disk off and on again to make it work properly.
- USB storage devices below USB 2.0 are supported as well. But they may not work properly with videos.
- A maximum of 999 folders or files can be recognized under one folder.
- It is recommended you use a certified USB storage device and cable. Otherwise, a USB storage device may not be detected or a playback error may occur.
- Only a USB memory stick can be used to play back the files distributed and stored by SuperSign Manager. A USB hard disk or multi-card reader will not work.
- Only an FAT 32 file formatted storage device can play back the files distributed and stored by SuperSign manager.
- A USB 3.0 storage device may not work.

## Using My Media

Provides video/ photo/ music files on your Monitor by connecting to a USB device

- 1 Connecting a USB device.
- 2 Press **INPUT** to access the **INPUT LIST**.
- 3 Press the Navigation buttons to scroll to USB device and press **OK**.
- 4 Press the Navigation buttons to scroll to the **VIDEO/ PHOTO/ MUSIC** you want and press **OK**.

Displays video/ photo/ music files on all devices connected to the Monitor.

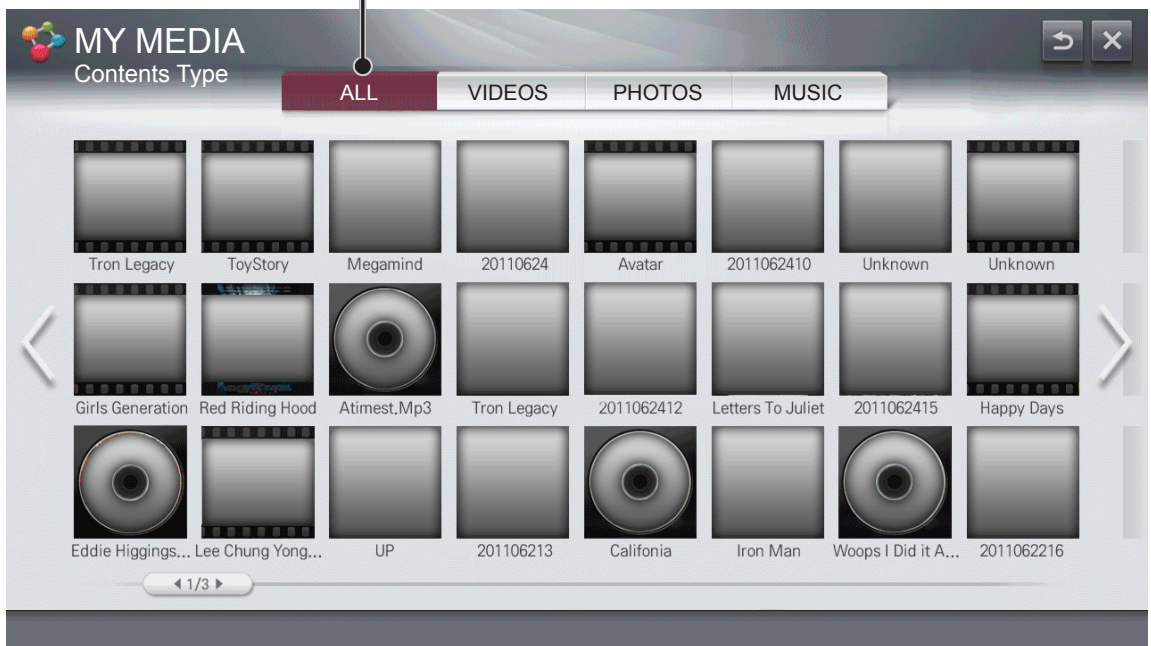

### Supported File Formats

<b>Supporting file</b>	<p>Maximum data transfer rate : 20 Mbps (megabits per second)</p> <p>External subtitle formats supported : *.smi, *.srt, *.sub (MicroDVD, SubViewer 1.0/2.0), *.ass, *.ssa, *.txt (TMPlayer), *.psb (PowerDivX)</p> <p>Internal subtitle formats supported : XSUB (supports internal subtitles generated from DivX6)</p>
------------------------	--

Type	Supporting file																																								
Video	• Maximum: 1920 x 1080 @30p																																								
	<table border="1"> <thead> <tr> <th>Extension</th> <th colspan="2">Codec</th> </tr> </thead> <tbody> <tr> <td rowspan="2">.asf .wmv</td> <td>Video</td> <td>VC-1 Advanced Profile, VC-1 Simple and Main Profile</td> </tr> <tr> <td>Audio</td> <td>WMA Standard, WMA 9 Professional</td> </tr> <tr> <td rowspan="2">.divx .avi</td> <td>Video</td> <td>DivX3.11, DivX4, DivX5, DivX6, XViD, H.264/AVC, Motion Jpeg</td> </tr> <tr> <td>Audio</td> <td>MPEG-1 Layer I, II, MPEG-1 Layer III (MP3), Dolby Digital, Dolby Digital Plus, LPCM, ADPCM, DTS</td> </tr> <tr> <td rowspan="2">.mp4 .m4v .mov</td> <td>Video</td> <td>H.264/AVC, MPEG-4 Part 2</td> </tr> <tr> <td>Audio</td> <td>AAC</td> </tr> <tr> <td rowspan="2">.mkv</td> <td>Video</td> <td>H.264/AVC</td> </tr> <tr> <td>Audio</td> <td>HE-AAC, Dolby Digital</td> </tr> <tr> <td rowspan="2">.ts .trp .tp</td> <td>Video</td> <td>H.264/AVC, MPEG-2, VC-1</td> </tr> <tr> <td>Audio</td> <td>MPEG-1 Layer I, II, MPEG-1 Layer III (MP3) Dolby Digital, Dolby Digital Plus, AAC</td> </tr> <tr> <td rowspan="2">.vob</td> <td>Video</td> <td>MPEG-1, MPEG-2</td> </tr> <tr> <td>Audio</td> <td>Dolby Digital, MPEG-1 Layer I, II, DVD-LPCM</td> </tr> <tr> <td rowspan="2">.mpg .mpeg</td> <td>Video</td> <td>MPEG-1</td> </tr> <tr> <td>Audio</td> <td>MPEG-1 Layer I, II</td> </tr> </tbody> </table>			Extension	Codec		.asf .wmv	Video	VC-1 Advanced Profile, VC-1 Simple and Main Profile	Audio	WMA Standard, WMA 9 Professional	.divx .avi	Video	DivX3.11, DivX4, DivX5, DivX6, XViD, H.264/AVC, Motion Jpeg	Audio	MPEG-1 Layer I, II, MPEG-1 Layer III (MP3), Dolby Digital, Dolby Digital Plus, LPCM, ADPCM, DTS	.mp4 .m4v .mov	Video	H.264/AVC, MPEG-4 Part 2	Audio	AAC	.mkv	Video	H.264/AVC	Audio	HE-AAC, Dolby Digital	.ts .trp .tp	Video	H.264/AVC, MPEG-2, VC-1	Audio	MPEG-1 Layer I, II, MPEG-1 Layer III (MP3) Dolby Digital, Dolby Digital Plus, AAC	.vob	Video	MPEG-1, MPEG-2	Audio	Dolby Digital, MPEG-1 Layer I, II, DVD-LPCM	.mpg .mpeg	Video	MPEG-1	Audio	MPEG-1 Layer I, II
	Extension	Codec																																							
	.asf .wmv	Video	VC-1 Advanced Profile, VC-1 Simple and Main Profile																																						
		Audio	WMA Standard, WMA 9 Professional																																						
	.divx .avi	Video	DivX3.11, DivX4, DivX5, DivX6, XViD, H.264/AVC, Motion Jpeg																																						
		Audio	MPEG-1 Layer I, II, MPEG-1 Layer III (MP3), Dolby Digital, Dolby Digital Plus, LPCM, ADPCM, DTS																																						
	.mp4 .m4v .mov	Video	H.264/AVC, MPEG-4 Part 2																																						
		Audio	AAC																																						
	.mkv	Video	H.264/AVC																																						
		Audio	HE-AAC, Dolby Digital																																						
	.ts .trp .tp	Video	H.264/AVC, MPEG-2, VC-1																																						
		Audio	MPEG-1 Layer I, II, MPEG-1 Layer III (MP3) Dolby Digital, Dolby Digital Plus, AAC																																						
	.vob	Video	MPEG-1, MPEG-2																																						
Audio		Dolby Digital, MPEG-1 Layer I, II, DVD-LPCM																																							
.mpg .mpeg	Video	MPEG-1																																							
	Audio	MPEG-1 Layer I, II																																							
Music	<table border="1"> <thead> <tr> <th>File type</th> <th>Item</th> <th>Info</th> </tr> </thead> <tbody> <tr> <td rowspan="3">mp3</td> <td>Bit rate</td> <td>32 Kbps - 320 Kbps</td> </tr> <tr> <td>Sample freq.</td> <td>16 kHz - 48 kHz</td> </tr> <tr> <td>Support</td> <td>MPEG1, MPEG2, Layer2, Layer3</td> </tr> </tbody> </table>			File type	Item	Info	mp3	Bit rate	32 Kbps - 320 Kbps	Sample freq.	16 kHz - 48 kHz	Support	MPEG1, MPEG2, Layer2, Layer3																												
	File type	Item	Info																																						
	mp3	Bit rate	32 Kbps - 320 Kbps																																						
		Sample freq.	16 kHz - 48 kHz																																						
Support		MPEG1, MPEG2, Layer2, Layer3																																							
Photo	<table border="1"> <thead> <tr> <th>File type</th> <th>Item</th> <th>Profile</th> </tr> </thead> <tbody> <tr> <td rowspan="2">jpeg, jpg, jpe</td> <td>Available file type</td> <td>SOF0: baseline SOF1: Extend Sequential SOF2: Progressive</td> </tr> <tr> <td>Photo size</td> <td>Minimum: 64 x 64 Maximum: Normal Type: 15360 (W) x 8640 (H) Progressive Type: 1920 (W) x 1440 (H)</td> </tr> </tbody> </table>			File type	Item	Profile	jpeg, jpg, jpe	Available file type	SOF0: baseline SOF1: Extend Sequential SOF2: Progressive	Photo size	Minimum: 64 x 64 Maximum: Normal Type: 15360 (W) x 8640 (H) Progressive Type: 1920 (W) x 1440 (H)																														
	File type	Item	Profile																																						
	jpeg, jpg, jpe	Available file type	SOF0: baseline SOF1: Extend Sequential SOF2: Progressive																																						
		Photo size	Minimum: 64 x 64 Maximum: Normal Type: 15360 (W) x 8640 (H) Progressive Type: 1920 (W) x 1440 (H)																																						



**Set Video Play.**

Menu	Description
<b>Repeat</b>	Turn on/off repeat function of movie playback. When turned on, the file within the folder will be played back repeatedly. Even when the repeated playback is turned off, it can run the playback if the file name is similar to the previous file.
<b>Audio Language</b>	Changes the Language Group of the audio during movie play. Files with a single audio track cannot be selected.
<b>Subtitle Language</b>	Turn on or off the subtitles.
<b>Language</b>	Activated for SMI subtitles and can select the language within the subtitles.
<b>Code Page</b>	Can select the font for subtitles. When set to default, same font as general menu will be used. - Sync: Adjusts the time synchronisation of the subtitles from -10 secs to +10 secs by steps of 0.5 secs during movie play. - Position: Changes the position of the subtitles either up or down during movie play. - Size: Selects your desired Subtitle size during movie play. - Color: Selects your desired Subtitle color during movie play.

 **NOTE**

- Only 10,000 of sync blocks are supported within a subtitle file.
- When playing a video, you can adjust the Picture Size by pressing the **ARC** button.
- Subtitles in your language are only supported when the OSD menu is also in this language.
- The code page options may be disabled depending on the language of the subtitle files.
- Select the appropriate code page for the subtitle files.

 **CAUTION**

- Some subtitles created by users may not work properly.
- The video and subtitle files should be placed in the same folder. For subtitles to display correctly, the video and subtitle files must have the same name.
- We do not support any stream that contains GMC (Global Motion Compensation) or Qpel (Quarterpel Motion Estimation).
- Only H.264 / AVC profile level 4.1 and lower is supported.
- The file size limit is dependent on the encoding environment.
- Video files created by some encoders may not be played back.
- Video files in formats other than the ones specified here may not be played back.
- Playback of video files stored on the USB device that do not support High Speed, may not work properly.
- DTS audio codec is support only with USB video file playback.

**Tips for using playing video files**

- Some special characters are not supported in subtitles.
- HTML tags are not supported in subtitles.
- Subtitles in languages other than the supported languages are not available.
- The screen may suffer temporary interruptions (image stoppage, faster playback, etc.) when the audio language is changed.
- A damaged movie file may not be played correctly, or some player functions may not be usable.
- If the video and audio structure of recorded file is not interleaved, either video or audio is outputted.
- HD videos with a maximum of 1920 X 1080 @ 25/30 P or 1280 X 720 @ 50/60 P are supported, depending on the frame.
- Videos with resolutions higher than 1920 X 1080 @ 25/30 P or 1280 X 720 @ 50/60 P may not work properly depending on the frame.
- Max bitrate of playable movie file is 20 Mbps. (only, Motion JPEG 10 Mbps)
- A movie file more than 30 GB in file size is not supported for playback.

## Viewing Photos

Controls playback and sets options while viewing pictures in full screen.

- 1 In the **MY MEDIA** screen, press the navigation button to scroll to **PHOTO** and press **OK**.
- 2 Press the navigation buttons to scroll to the file you want and press **OK**.

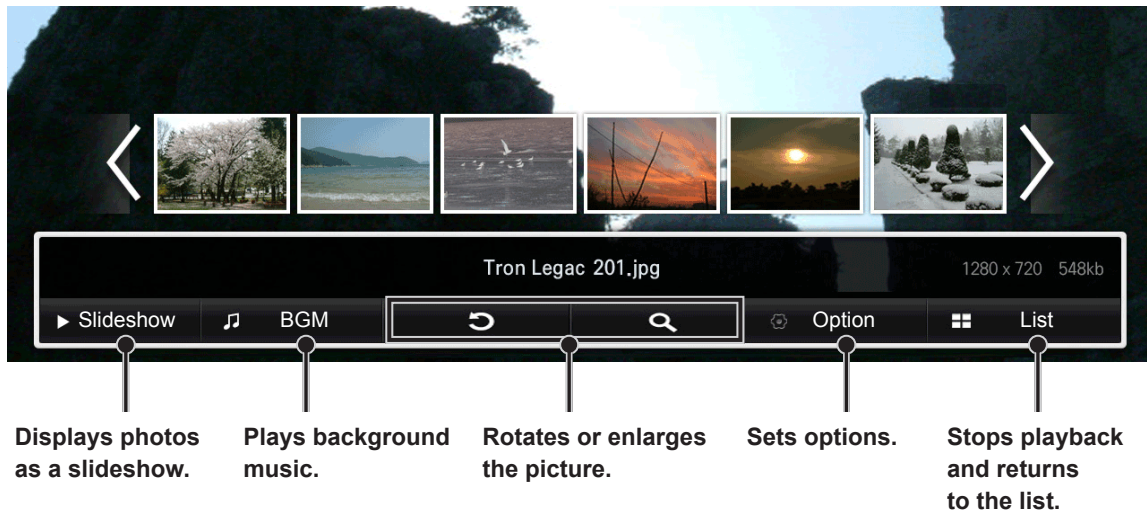

Displays photos as a slideshow.

Plays background music.

Rotates or enlarges the picture.

Sets options.

Stops playback and returns to the list.

Menu	Description
<b>Slideshow</b>	Starts or stops a slideshow with selected photos. If there are no selected photos, all photos saved in the current folder display during a slideshow. To set a slideshow speed, select <b>Option</b> .
<b>BGM</b>	Turns the background music on or off. To set the background music folder, select <b>Option</b> . You can adjust option by <b>SETTINGS</b> button on the remote control.
	Rotates photos clockwise or counter-clockwise. (90 °, 180 °, 270 °, 360 °)
	Zooms the photos in to 100 %, 120 %, 140 %, 160 %, 180 %, or 200 %. You can reposition a photo that is 120 % zoomed in or more.
<b>Option</b>	<p><b>Set Photo View.</b></p> <ul style="list-style-type: none"> <li>- Slide Show Speed: Sets the Slide Show speed. (Options: Fast, Medium, or Slow.)</li> <li>- Slide Show Effect: Sets how photos transition. (Options: Fade in/out, Slide, or Off.)</li> <li>- BGM: Sets the folder path for background music.</li> <li>- Repeat: Select to repeat all songs, one song, or to turn this feature off.</li> <li>- Random: Sets files to play randomly or sequentially.</li> <li>• <b>Speaker:</b> Directs sound through the external speakers connected to the Speaker Out port.</li> <li>• <b>Sleep Timer:</b> Sets the specific time to turn the monitor off automatically.</li> </ul> <div style="border: 1px solid black; padding: 5px; margin-top: 10px;"> <p><b>NOTE</b></p> <ul style="list-style-type: none"> <li>• For a description of each menu option, refer to Set Video in User Settings.</li> <li>• For a description of each menu option, refer to Set Audio in User Settings.</li> </ul> </div>
<b>List</b>	Stops the playback and returns to the list.

## Listening to Music

Controls playback and sets options while playing music.

- 1 In the **MY MEDIA** screen, press the navigation button to scroll to **MUSIC** and press **OK**.
- 2 Press the navigation buttons to scroll to the file you want and press **OK**.

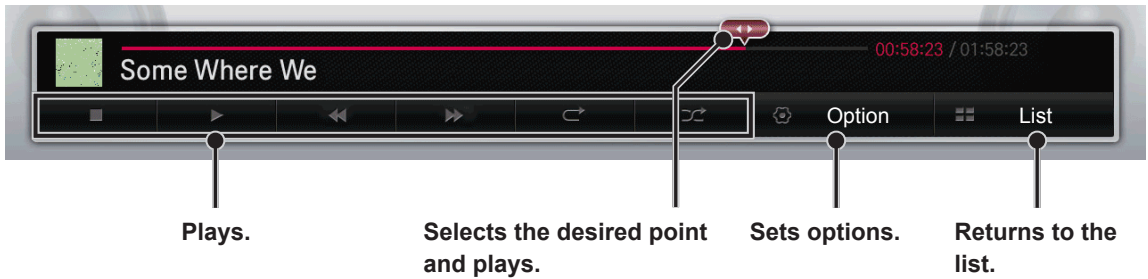

Remote Button	Description
	Stops playback.
	Plays a music file.
	Pauses or resumes playback.
	Skips to the next file.
	Skips to the previous file.
	When playing, When you press the  button, the previous music file will be played. When you press the  button, the next music file will be played.
<b>ENERGY SAVING</b> 	Press the <b>ENERGY SAVING</b> button repeatedly to increase the brightness of your screen.
<b>SETTINGS</b>	<ul style="list-style-type: none"> <li>• <b>Speaker:</b> Directs sound through the external speakers connected to the Speaker Out port.</li> <li>• <b>Sleep Timer:</b> Sets the specific time to turn the monitor off automatically.</li> </ul> <p><b>NOTE</b></p> <ul style="list-style-type: none"> <li>• For a description of each menu option, refer to Set Audio in User Settings.</li> </ul>
< or >	When using the < or > button during playback a cursor indicating the position can be played.



# CUSTOMIZING SETTINGS

## PICTURE Settings

- 1 Press the navigation buttons to scroll to **PICTURE**.
- 2 Press the navigation buttons to scroll to the setting or option you want and press **OK**.
  - To return to the previous level, press **BACK**.
- 3 When you are finished, press **EXIT**.  
When you return to the previous menu, press **BACK**.

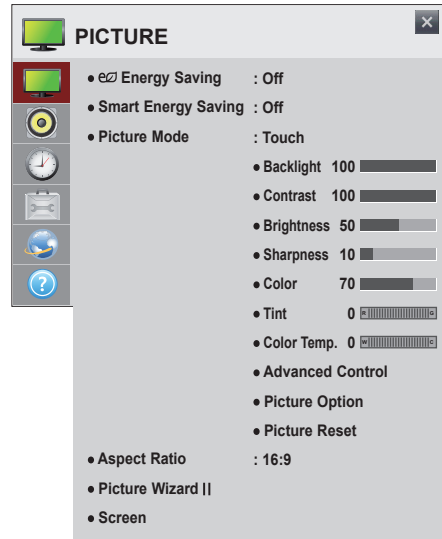

The available **PICTURE** settings are described in the following:

Setting	Description	
 <b>Energy Saving</b>	Reduces power consumption by adjusting screen brightness.	
	Level	
	<b>Off</b>	Turns off Energy Saving mode.
	<b>Minimum/Medium/Maximum</b>	Applies the pre-set Energy Saving mode.
	<b>Screen off</b> Screen is turned off after 3 seconds and only sound is played. Press any button on the remote control to turn the screen back on.	
<b>Smart Energy Saving</b>	Adjusts the backlight and contrast depending on the screen brightness.	
	Level	
	<b>Off</b>	Disables the Smart Energy Saving function.
	<b>On</b> Enables the Smart Energy Saving function to save power consumption as much as the value set in the smart energy saving rate.	

Setting	Description	
<b>Picture Mode</b>	Selects the picture mode optimized for the viewing environment or the programme.	
	Mode	
	<b>Vivid</b>	Heightens contrast, brightness and sharpness to display vivid images.
	<b>Standard</b>	Displays images in standard levels of contrast, brightness and sharpness.
	<b>Cinema/ Game</b>	Displays images that have been optimized for movies or games.
	 <b>Expert1, 2</b>	Menu for adjusting picture quality that allows experts and amateurs to enjoy the best Monitor viewing. This menu is ISF-certified and provided for picture tuning experts. (ISF logo can only be used on ISF-certified Monitor units.) ISFccc: Imaging Science Foundation Certified Calibration Control
	<b>Touch</b>	Optimizes the video image for touch features.
<b>Aspect Ratio</b>	Changes the image size to view images at its optimal size.	
<b>Picture Wizard II</b>	Use the remote control and follow the instructions of the Picture Wizard to calibrate and adjust for optimum picture quality without expensive pattern devices or help from a specialist. Follow the instructions to obtain the optimum picture quality.	
<b>Screen (In RGB Mode Only)</b>	Adjusts picture in RGB-PC mode.	
	Option	
	<b>Resolution</b>	Selects a proper resolution. See "Customizing PC display options".
	<b>Auto Config.</b>	Adjusts the screen position, clock, and phase automatically. The displayed image may be unstable for a few seconds while the configuration is in progress.
	<b>Position/ Size/ Phase</b>	Adjusts the options when the picture is not clear, especially when characters are shaky. Run Auto Config. before adjusting these.
	<b>Reset</b>	Restores all options to the default setting.

**NOTE**

- When using the **Smart Energy Saving** function, the screen may look saturated in the white area of a still image.
- If **Energy Saving** is set to **Minimum/ Medium/ Maximum** the **Smart Energy Saving** function is disabled.
- If **Energy Saving** is set to **Maximum/ Screen off** the **Backlight** function is disabled.
- Depending on the input signal, the available range of picture modes may differ.
-  Expert mode is for picture tuning professionals to control and fine-tune using a specific image. For normal images, the effects may not be dramatic.
- If the Picture Mode setting in the Picture menu is set to **Vivid, Standard, Cinema, or Game**, the subsequent menus will be automatically set.

### Picture Mode options

Setting	Description
<b>Backlight</b>	Adjusts the display brightness by varying the brightness of the LCD panel.
<b>Contrast</b>	Adjusts the difference between bright and dark regions of the screen.
<b>Brightness</b>	Adjusts the overall screen brightness.
<b>Sharpness</b>	Adjusts the sharpness of the borders between bright and dark.
<b>Color</b>	Adjusts the color on the screen darker or lighter.
<b>Tint</b>	Adjusts the red/green color balance.
<b>Color Temp.</b>	Adjusts the overall tone of color to warm or cool.
<b>Advanced Control</b>	Adjusts the advanced options. Refer to the Advanced image options.
<b>Picture Option</b>	Adjusts detailed setting for images.
<b>Picture Reset</b>	Restores the options to the default setting. Each picture mode is reset. Select the picture mode you wish to reset.

### Advanced image options

Setting	Description
<b>Dynamic Contrast</b>	Adjusts the contrast to the optimal level according to the brightness of the image.
<b>Dynamic Color</b>	Adjusts color for more natural-looking colors.
<b>Clear White</b>	Enhances whites on screen to make the image brighter and sharper.
<b>Preferred Color</b>	<ul style="list-style-type: none"> <li>● Skin Color: Skin Color spectrum can be separately set to implement the skin Color as defined by the user.</li> <li>● Grass Color: Natural color spectrum (meadows, hills, etc.) can be separately set.</li> <li>● Sky Color: Sky color is set separately.</li> </ul>
<b>Super Resolution</b>	Provides a crystal-clear picture by improving the details in areas where the picture is blurry or unclear.
<b>Gamma</b>	Sets the gradation curve according to the output of the picture signal in relation to the input signal.
<b>Color Gamut</b>	Selects the range of colors that can be expressed.

## Picture Option

Setting	Description
<b>Noise Reduction</b>	Reduces screen noise in the video.
<b>MPEG Noise Reduction</b>	Reduces noise caused by compressing digital video.
<b>Black Level</b>	Adjusts the brightness or darkness of the screen to suit the black level of the picture input using the degree of darkness (black level) of the screen.
<b>Real Cinema</b>	Optimizes the screen for movie viewing.
<b>Eye Care</b>	Adjusts screen brightness to prevent eye glare. (Depending on model)
<b>LED Local Dimming</b>	<p>Brightens bright areas and darkens dark areas of the image for maximum contrast and minimum blur while reducing power consumption.</p> <ul style="list-style-type: none"> <li>● <b>Off</b>: Turns off <b>LED Local Dimming</b>.</li> <li>● <b>Low</b>: Expresses natural black tones. Uses this setting for viewing movies.</li> <li>● <b>Medium</b>: Deepens black tones compared to <b>Low</b>.</li> <li>● <b>High</b>: Deepens black tones and delivers clearer image than <b>Medium</b>. Perfect for viewing in brightly lit areas.</li> </ul>
<b>TruMotion</b>	<p>Corrects images to display smoother motion sequences.</p> <ul style="list-style-type: none"> <li>● <b>Off</b>: Turns off LED Local Dimming.</li> <li>● <b>Smooth: De-Judder / De-Blur</b> value is set to 3.</li> <li>● <b>Clear: De-Judder / De-Blur</b> value is set to 7.</li> <li>● <b>Clear Plus</b>: The screen appears clearer when <b>Clear</b> is selected.</li> <li>● <b>User: De-Judder / De-Blur</b> can be set manually.</li> </ul> <p>- <b>De-Judder</b>: This function adjusts juddering of the screen.  - <b>De-Blur</b>: This function adjusts and eliminates blurring of the screen.</p>

**NOTE**

- Setting **LED Local Dimming** to **Medium / High** reduces power consumption.
- If the video signal is 60 Hz, **TruMotion** may not work.

## Using the Additional Options

### Adjusting Aspect Ratio

Resize the image to view the image at its optimal size by pressing **ARC** while you are watching content.



#### CAUTION

- If a fixed image displays on the screen for a long period of time, it will be imprinted and become a permanent disfigurement on the screen. This is image retention or burn-in and not covered by the warranty.
- If the aspect ratio is set to 4:3 for a long period of time, image burn may occur on the letterboxed area of the screen.
- When using the touch screen monitor, it is recommended to set the screen aspect ratio to Just Scan.

MODE \ ARC	AV	RGB	Display Port		DVI-D		HDMI	
		PC	DTV	PC	DTV	PC	DTV	PC
16:9	o	o	o	o	o	o	o	o
Just Scan	x	x	o	x	o	x	o	x
Original	o	x	o	x	o	x	o	x
4:3	o	o	o	o	o	o	o	o
Zoom	o	x	o	x	o	x	o	x
Cinema Zoom 1 - 16	o	x	o	x	o	x	o	x



#### NOTE

- DTV: Blu-ray, DVD, VCR, Home theater, AV Receiver, Set-top Box, Cable Box, Satellite, IPTV, TV, Smart Box, Game, Smart phone, Camera, and Camcorder.
- PC: PC, Laptop Computer

- **16:9** : This selection will allow you to adjust the picture horizontally, in linear proportion, to fill the entire screen (useful for viewing 4:3 formatted DVDs).

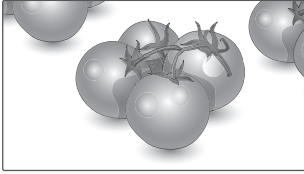

- **4:3** : This selection will allow you to view a picture with an original 4:3 aspect ratio, black bars will appear on both the left and right of the screen. This may cause image retention around the border of the black bars.

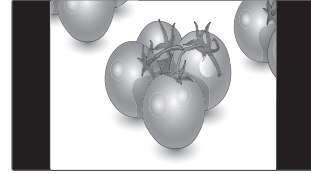

- **Just Scan** : This Selection will allow you view the picture of best quality without loss of original picture in high resolution image. Note: If there is noise in original Picture, You can see the noise at the edge.



- **Zoom** : This selection will allow you to view the picture without any alteration, while filling the entire screen. However, the top and bottom of the picture will be cropped.

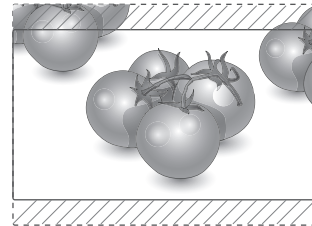

- **Original** : The aspect ratio is not adjusted from the original. It is set by the program being watched.

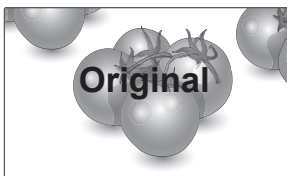

- **Cinema Zoom 1 - 16** : Choose Cinema Zoom when you want to enlarge the picture in correct proportion.

Note: When enlarging or reducing the picture, the image may become distorted.

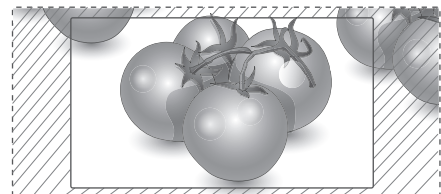

## SOUND Settings

- 1 Press the navigation buttons to scroll to **SOUND**.
- 2 Press the navigation buttons to scroll to the setting or option you want and press **OK**.  
- To return to the previous level, press **BACK**.
- 3 When you are finished, press **EXIT**.  
When you return to the previous menu, press **BACK**.

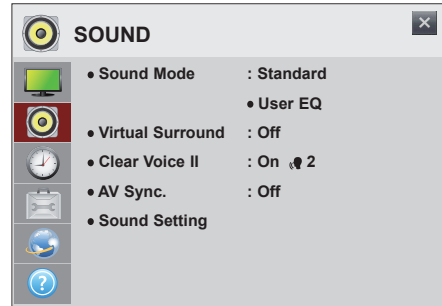

The available **SOUND** options are described in the following:

Setting	Description	
<b>Sound Mode</b>	Allows optimized sound for custom monitor installation.	
	Mode	
	<b>Standard</b>	Suitable for all types of video.
	<b>Music/ Cinema/ Sport/ Game</b>	Sets audio optimized for a specific genre.
	<b>Vivid</b>	Delivers distinct voices with rich bass and clear, high-pitched sounds.
<b>User Setting</b>	Adjusts the volume to a level of your choice using the User EQ. <ul style="list-style-type: none"> <li>● <b>User EQ:</b></li> <li>- <b>100 Hz/ 300 Hz/ 1 kHz/ 3 kHz/ 10 kHz</b> : Sets EQ by manual adjustment of sound bands.</li> <li>- <b>Reset</b> : Resets the equalizer value changed by the user.</li> </ul>	
<b>Virtual Surround</b>	LG's proprietary audio processing technology allows 5.1 channel-like surround sound from two speakers. * If <b>Clear Voice II</b> is set to <b>On</b> , <b>Virtual Surround</b> will not be chosen.	
<b>Clear Voice II</b>	Boosts voice clarity.	
<b>AV Sync.</b>	Synchronizes video and audio directly when they do not match. If you set AV Sync. to ON, you can adjust the sound output to the screen image. <ul style="list-style-type: none"> <li>● <b>Speaker:</b> Adjusts the synchronization of the sound from the speakers. The - button makes the sound output faster and the + button slower than the default value.</li> <li>● <b>Bypass</b> : The audio of an external device without audio delay. Audio may be output before video as it takes time to process video input into the Monitor.</li> </ul>	
<b>Sound Setting</b>	<ul style="list-style-type: none"> <li>● <b>Digital Audio Input</b></li> <li>- <b>HDMI/Display Port:</b> Outputs the sound of digital signal from HDMI and display ports through the monitor speaker.</li> <li>- <b>Audio In:</b> Outputs the sound through the monitor speaker by connecting HDMI and display ports to the Audio In port.</li> <li>● <b>Balance</b> : Adjusts balance between the left and right speakers according to your room environment.</li> <li>● <b>Speaker</b> : *The external speaker is sold separately.</li> <li>- <b>On:</b> Outputs the sound through the external speaker connected to the speaker out port of the monitor.</li> <li>- <b>Off:</b> Does not output the sound through the external speaker connected to the speaker out port of the monitor. Use this option when using an external sound device.</li> </ul>	

**NOTE**

- The remote control does not have hotkey to **Sound Mode**.

## TIME Settings

- 1 Press the navigation buttons to scroll to **TIME**.
- 2 Press the navigation buttons to scroll to the setting or option you want and press **OK**.  
- To return to the previous level, press **BACK**.
- 3 When you are finished, press **EXIT**.  
When you return to the previous menu, press **BACK**.

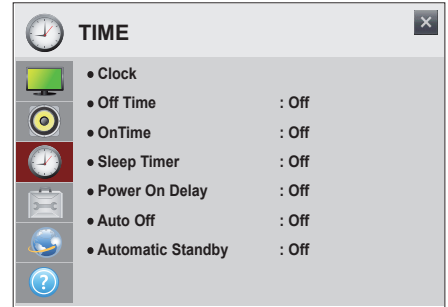

The available **TIME** settings are described in the following:

Setting	Description
<b>Clock</b>	Checks or changes the time.
<b>Off Time/ On Time</b>	Sets the Off/On time.
<b>Sleep Timer</b>	Turns off the Monitor after a preset number of minutes.
<b>Power On Delay</b>	When connecting multiple monitors and turning the power on, the monitors are turned on individually to prevent overload.
<b>Auto Off</b>	If Auto off is active and there is no input signal, the set switches to off mode automatically after 15 minutes.
<b>Automatic Standby</b>	If you do not use the monitor for more than 4 hours, it will be in off mode automatically.

### ! NOTE

- To use **Off Time/ On Time**, set the current time correctly.
- **Off Time/ On Time** can be saved for up to seven schedules; the Monitor is turned on or off at the preset time in the schedule list. If multiple preset times are stored in the schedule list, this function works at the nearest time from the current time.
- The scheduled power-off function works properly only when the device time is set correctly.
- When the scheduled power-on and power-off times are the same, the power-off time has priority over the power-on time if the set is turned on, and vice versa if the set is turned off.
- The **Automatic Standby** and **Auto off** functions may not be available in some countries.
- The remote control does not have hotkey to **Sleep Timer**.



## OPTION Settings

- 1 Press the navigation buttons to scroll to **OPTION**.
- 2 Press the navigation buttons to scroll to the setting or option you want and press **OK**.  
- To return to the previous level, press **BACK**.
- 3 When you are finished, press **EXIT**.  
When you return to the previous menu, press **BACK**.

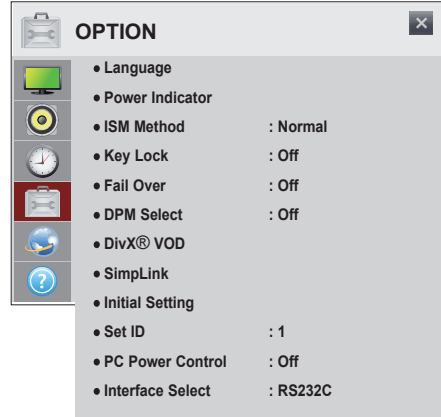

The available **OPTION** settings are described in the following:

Setting	Description						
<b>Language</b>	Selects a language for the display text.						
<b>Power Indicator</b>	Turns the standby light in the front panel of the monitor on/off.						
<b>ISM Method</b>	This function removes image sticking which is caused by prolonged display of static images.						
	Setting						
	<table border="1"> <tr> <td><b>Normal</b></td> <td>Minimizes image sticking by gradually lowering the brightness when displaying static images and by increasing the brightness when displaying moving images.</td> </tr> <tr> <td><b>Color Wash</b></td> <td>Removes image sticking by moving every pixel in a certain pattern on the screen for a specific period of time. Please use this function to remove temporary image sticking.</td> </tr> </table>	<b>Normal</b>	Minimizes image sticking by gradually lowering the brightness when displaying static images and by increasing the brightness when displaying moving images.	<b>Color Wash</b>	Removes image sticking by moving every pixel in a certain pattern on the screen for a specific period of time. Please use this function to remove temporary image sticking.		
<b>Normal</b>	Minimizes image sticking by gradually lowering the brightness when displaying static images and by increasing the brightness when displaying moving images.						
<b>Color Wash</b>	Removes image sticking by moving every pixel in a certain pattern on the screen for a specific period of time. Please use this function to remove temporary image sticking.						
<b>Key Lock</b>	Key input does not work. This prevents invalid key input.						
<b>Fail Over</b>	If there is no input signal, it automatically switches to another input with signal.						
	Setting						
	<table border="1"> <tr> <td><b>Off</b></td> <td>Turns off Fail Over.</td> </tr> <tr> <td><b>Auto</b></td> <td>Attempts to find another input source having video signal according to the defined input order if no video signal comes from the current input source.</td> </tr> <tr> <td><b>Manual</b></td> <td>The input source changes according to the specified order. If there is no video signal from the specified input source, then the current input source remains.</td> </tr> </table>	<b>Off</b>	Turns off Fail Over.	<b>Auto</b>	Attempts to find another input source having video signal according to the defined input order if no video signal comes from the current input source.	<b>Manual</b>	The input source changes according to the specified order. If there is no video signal from the specified input source, then the current input source remains.
	<b>Off</b>	Turns off Fail Over.					
<b>Auto</b>	Attempts to find another input source having video signal according to the defined input order if no video signal comes from the current input source.						
<b>Manual</b>	The input source changes according to the specified order. If there is no video signal from the specified input source, then the current input source remains.						
<b>DPM Select</b>	Turns the energy saving mode on/off.						
<b>DivX® VOD</b>	Registers or releases DivX. Checks DivX Registration Code for playing DivX-protected videos. Register at <a href="http://vod.divx.com">http://vod.divx.com</a> . Uses Registration Code to rent or purchase movies at <a href="http://www.divx.com/vod">www.divx.com/vod</a> . * Rented/purchased DivX files cannot be played if the DivX Registration Code of a different device is used. Use only the DivX Registration Code granted to this device. * Converted files not conforming to the DivX Codec Standard may not play or may produce abnormal images and sound.						
<b>SimpLink</b>	SimpLink is a feature that enables you to control and manage various multimedia devices conveniently using the Monitor remote control.						
<b>Initial Setting</b>	Deletes all optional settings and returns to initial default mode.						

Setting	Description	
<b>Set ID</b>	You can assign a unique Set ID NO (name assignment) to each product when several products are connected for display. Specify the number (1 to 255) using the button and exit. Use the assigned Set ID to individually control each product using the Product Control Program.	
<b>PC Power Control</b>	Controls the power of the monitor with Media Player turned on. <b>On:</b> Turns on or off the monitor with Media Player on. <b>Off:</b> Turns on or off the whole system.	
<b>Interface Select</b>	Sets communication with Media Player and the connected PC.	
	Option	
	<b>RS232C</b>	Communicates with the connected PC in serial mode.
	<b>SuperSign</b>	Communicates with Media Player.

## NETWORK Settings

- 1 Press the navigation buttons to scroll to **NETWORK**.
- 2 Press the navigation buttons to scroll to the setting or option you want and press **OK**.  
- To return to the previous level, press **BACK**.
- 3 When you are finished, press **EXIT**.  
When you return to the previous menu, press **BACK**.

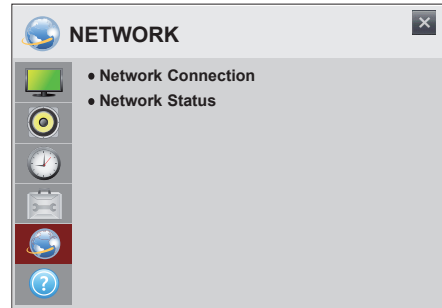

The available **NETWORK** settings are described in the following:

Setting	Description
<b>Network Connection</b>	Configure the network settings.
<b>Network Status</b>	Display the network status.

## SUPPORT Settings

- 1 Press the navigation buttons to scroll to **SUPPORT**.
- 2 Press the navigation buttons to scroll to the setting or option you want and press **OK**.  
- To return to the previous level, press **BACK**.
- 3 When you are finished, press **EXIT**.  
When you return to the previous menu, press **BACK**.



The available **SUPPORT** settings are described in the following:

Setting	Description
<b>Product/Service Info.</b>	Displays the model name, software version, serial number, used time, MAC address and homepage information.

# MAKING CONNECTIONS

Connect various external devices to the ports on the monitor's back panel.

- 1 Find an external device you want to connect to your monitor shown on the following illustration.
- 2 Check the connection type of the external device.
- 3 Go to the appropriate illustration and check the connection details.

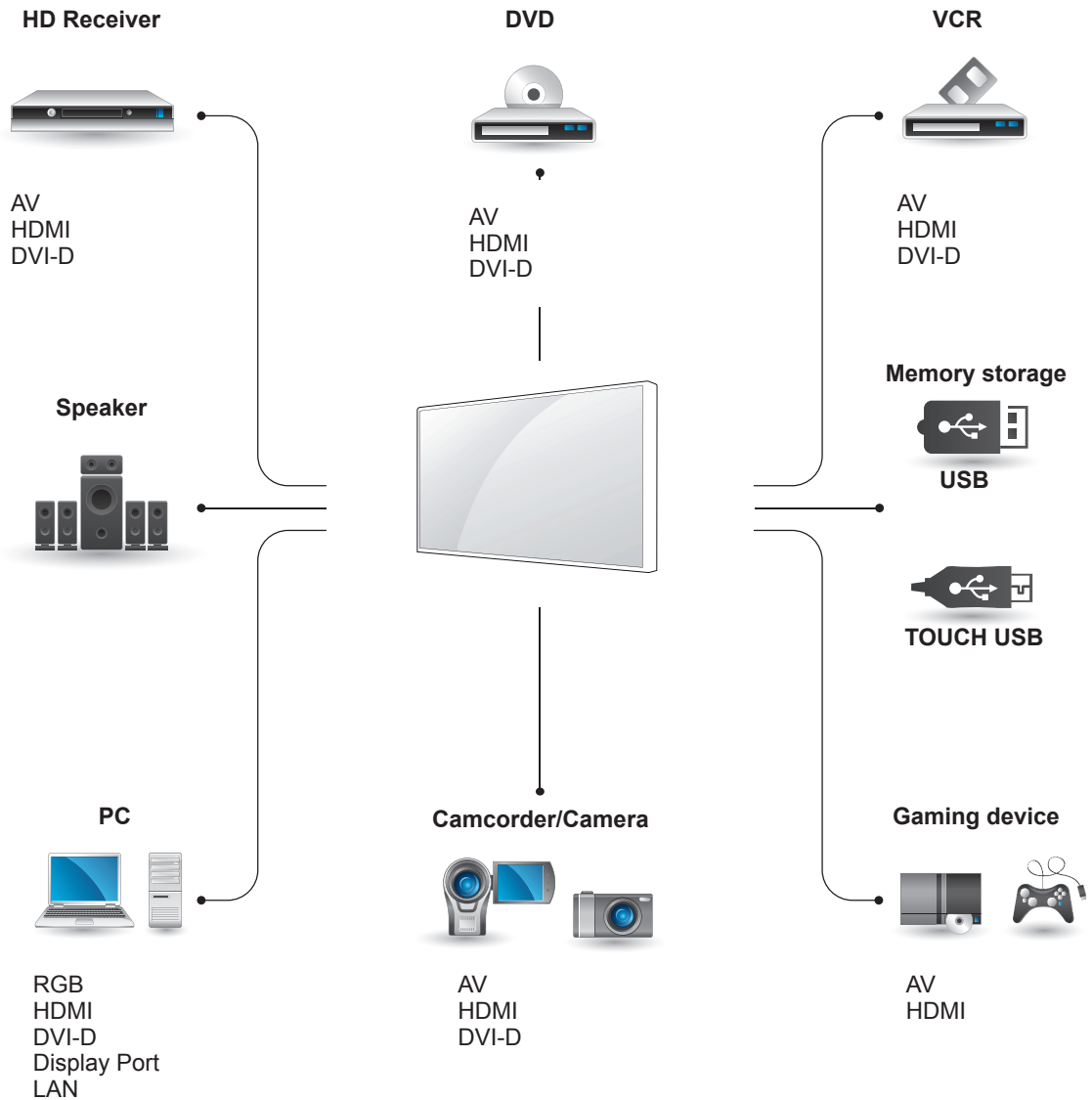

## NOTE

- If you connect a gaming device to the monitor, use the cable supplied with the gaming device.

## External Device Connection

Connect a HD receiver, DVD, or VCR player to the monitor and select an appropriate input mode.

### HDMI Connection

Transmits the digital video and audio signals from an external device to the monitor.  
Connect the external device and the monitor with the HDMI cable as shown on the following illustration.

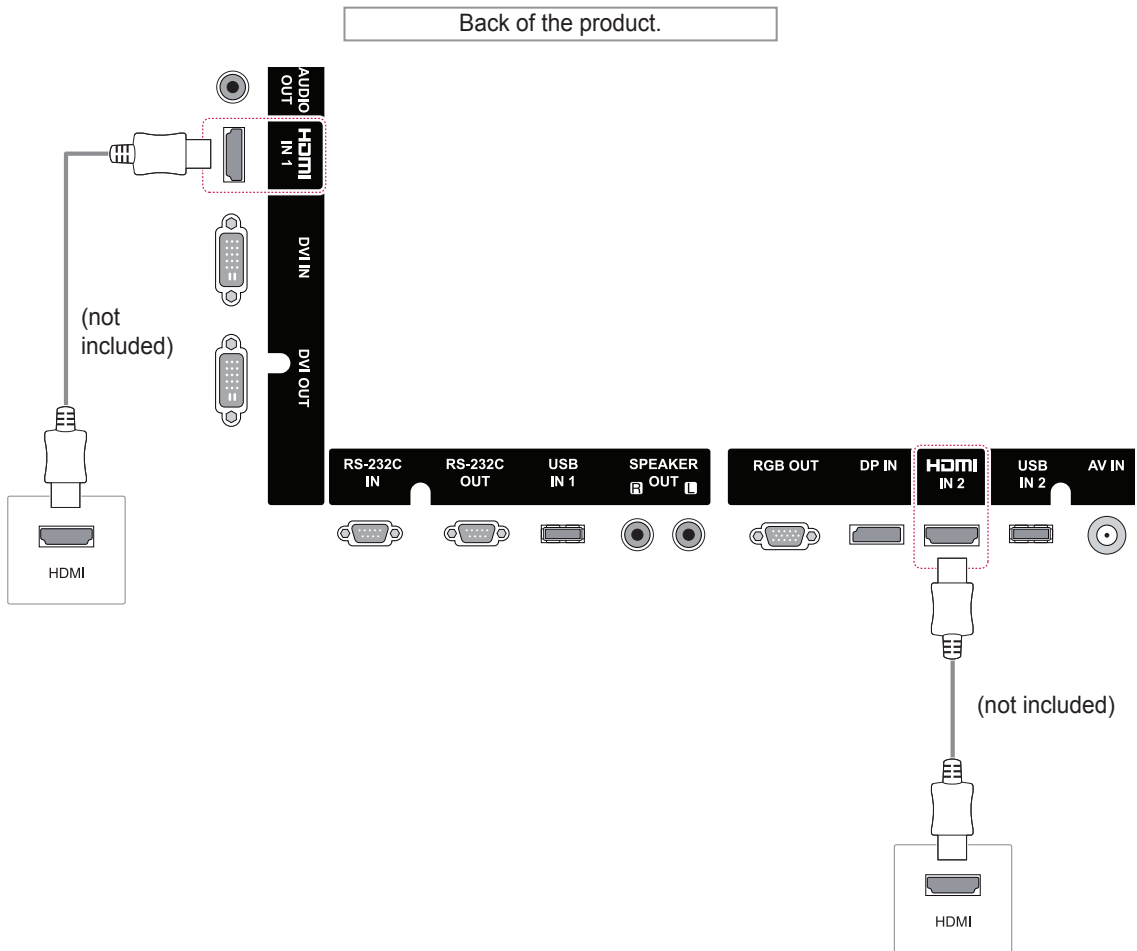

**NOTE**

- Use a High Speed HDMI™ Cable.
- High Speed HDMI™ Cables are tested to carry an HD signal up to 1080p and higher.

## AV (CVBS) Connection

Transmits the analog video and audio signals from an external device to the monitor. Connect the external device and the Monitor with the 15-pin signal to RCA cable as shown on the following illustration.

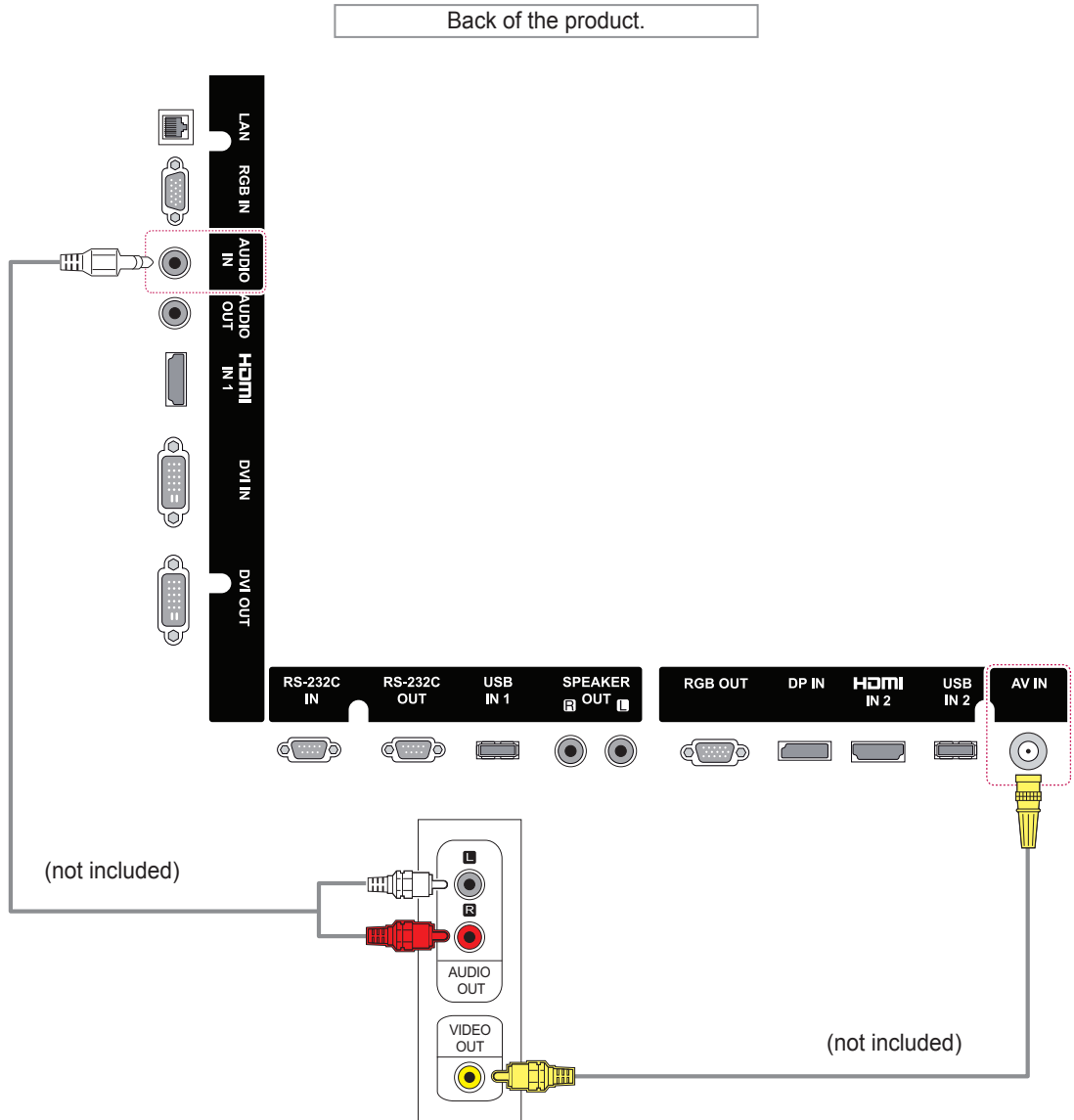

## Connecting to a USB

Connect a USB storage device such as a USB flash memory, external hard drive, MP3 player or a USB memory card reader to the Monitor and access the USB menu to use various multimedia files.

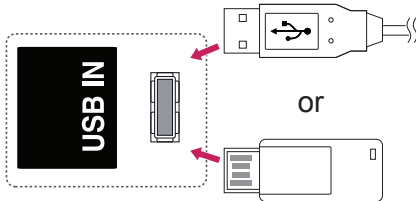

## Connecting to the LAN

**A** Connect PC to monitor directly.

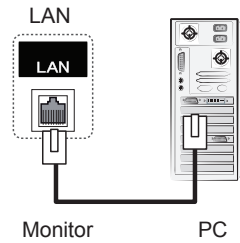

**B** Using a router (Switch)

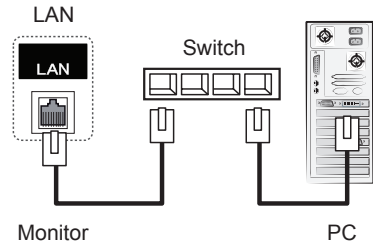

**C** Using the Internet.

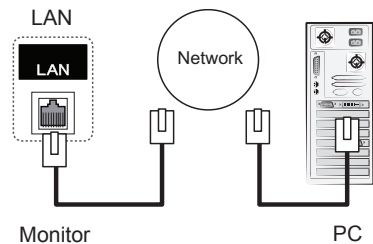

### ! NOTE

- Using LAN establishes communication between your PC and the monitor and enables you to use the OSD menus on the PC as well as on the monitor.

## Daisy Chain Monitors

Use this function to share the RGB video signal with other monitors without having to use a separate signal splitter box.

To use different products connected to each other connect one end of the signal input cable (15-pin D-Sub Signal Cable) to the RGB OUT connector of product 1 and connect the other end to the RGB IN connector of other products

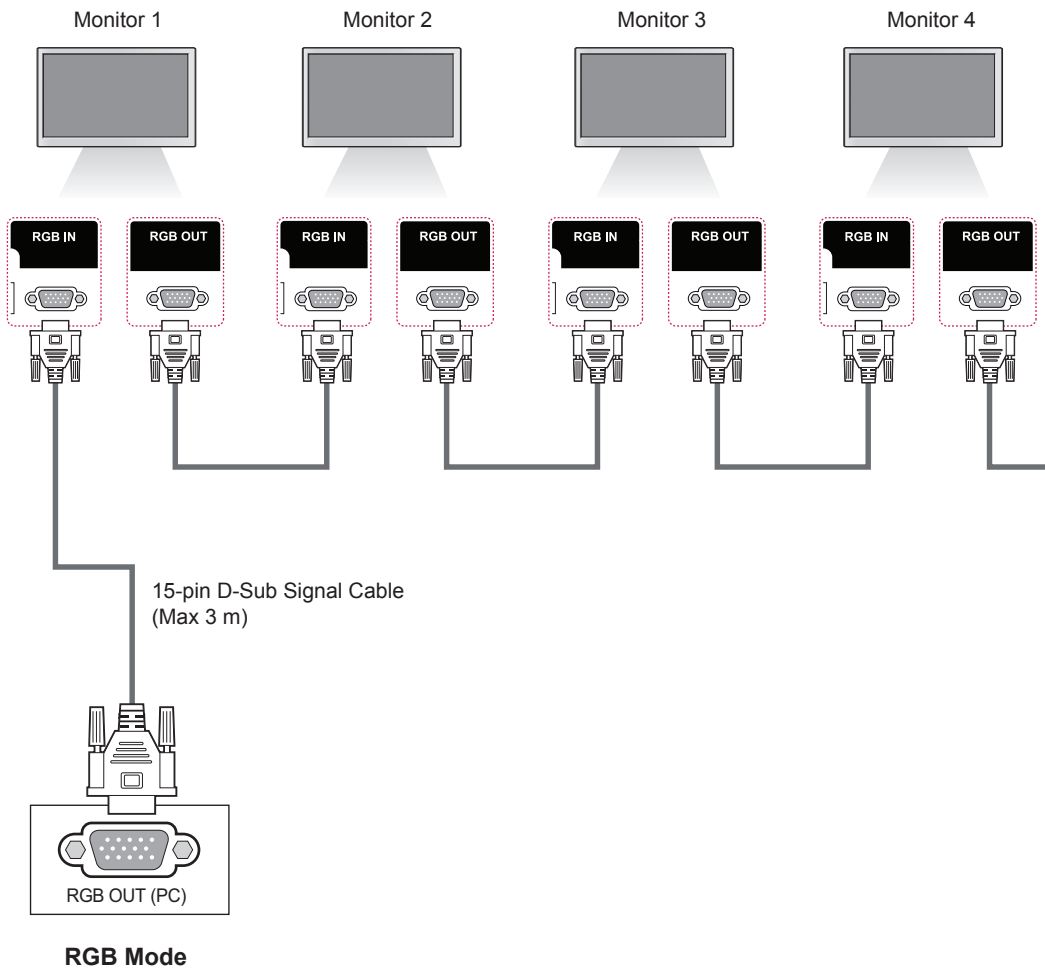

### NOTE

- The number of monitors that can be connected to one output may vary depending on signal status and cable loss. If the signal status is good, and there is no cable loss, it is possible to connect up to 9 monitors. If you want to connect more than this number of monitors, it is recommended to use a distributor.
- When multi-connecting in/out cascade format, no loss cables are recommended.
- When using an HDMI - DVI conversion cable or a gender, it may not be compatible with the product due to the characteristics of the signal.



# USING THE TOUCH SCREEN

## To Use the Touch Screen on Windows 7

Plug a USB cable into a TOUCH USB port on the back of the monitor.

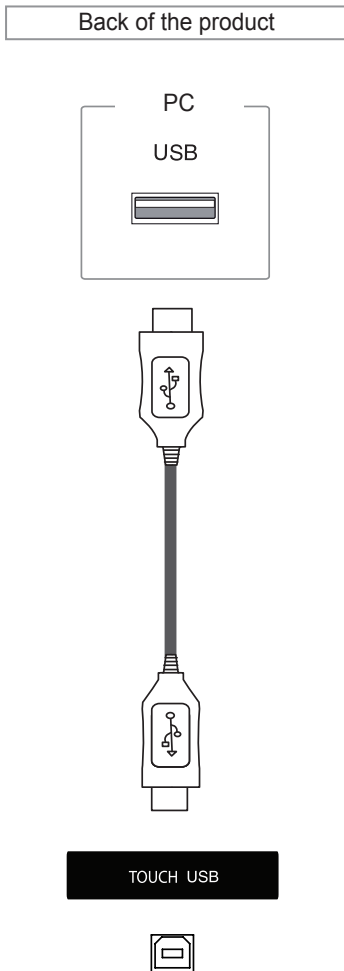

Then, connect the USB cable to your PC so that it automatically recognizes the touch screen monitor.

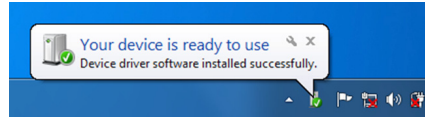

Go to Control Panel > System and Security > System. You will see the number of touch-points supported under Pen and Touch.

### ! CAUTION

- Once your PC recognizes the monitor, you will be able to use the touch screen.

### ! NOTE

- The monitor can respond to 10 Touch Points when connected to a Windows 7 computer.
- When using the touch screen monitor, it is recommended to set the screen aspect ratio to Just Scan.
- For more information about gestures and settings on Windows 7, refer to Windows Help.

## Gestures and Settings on Windows 7

For information about gestures and settings on Windows 7, refer to the Windows Help.

## Precaution When Using the Touch Screen



### CAUTION

- The monitor is optimized for indoor use.
- The touch screen monitor is optimized for Windows 7.
- Do not remove the USB cable when using the touch screen monitor.
- If touch does not respond, remove the USB cable and connect it back in ten seconds.
- Touch responds when the monitor is powered on.
- Touch accuracy is optimized by using full screen mode.
- Your action may not work properly on the edge area of the touch screen.
- If the 10 touch-points are not detected, restart your PC. (Windows 7)
- The touch operation (e.g. touches count, gesture, etc.) may vary depending on the content.
- The spot that you try to touch and the one which is actually touched on the screen may differ depending on the angle you view the monitor screen.

## LG Touch Screen Software

### Specifications

Minimum System Requirements for Windows PC	CPU	Intel Core 2 Duo or higher
	RAM	1 GB or more
Recommended System Requirements for Windows PC	CPU	Intel Core i3 or higher
	RAM	2 GB or more
Supported OS	Windows 7 professional, Ultimate (32/64 bit)	

### Precaution When Using LG Touch Screen Software



#### CAUTION

- When running a separate application on LG Touch Screen software, the application screen may flicker.
- When using multi-touch feature while running PowerPoint on LG Touch Screen software, the Touch Screen software may be closed abnormally.
- To play or record video on the LG Touch Screen software, Windows Media Player 10 or higher and Microsoft Expression Encoder 4 SP2 are required.
- LG Touch Screen software supports Microsoft Office 2007 or a later version.
- If the print area is not aligned to the paper size, select the "Fit to Page" option.
- When you print to the XPS document writer, the "Save the file as" pop-up window may appear behind the LG Touch Screen software.
- To underline the text in the textbox, apply the underline after entering the text.

# TROUBLESHOOTING

## No image is displayed

Problem	Resolution
Is the product power cord connected?	<ul style="list-style-type: none"> <li>• See if the power cord is properly connected to the outlet.</li> </ul>
Is the power indicator light on?	<ul style="list-style-type: none"> <li>• See if the power switch is turned on.</li> <li>• May need service.</li> </ul>
Power is on, power indicator is red but the screen appears extremely dark.	<ul style="list-style-type: none"> <li>• Adjust brightness and contrast again.</li> <li>• Backlight may need repair.</li> </ul>
The power indicator amber?	<ul style="list-style-type: none"> <li>• If the product is in power saving mode, move the mouse or press any key.</li> <li>• Turn both devices off and then back on.</li> </ul>
Does the 'Out of range' message appear?	<ul style="list-style-type: none"> <li>• The signal from the PC (video card) is out of the vertical or horizontal frequency range of the product. Adjust the frequency range by referring to the Specifications in this manual.</li> </ul>
Does the 'Check signal cable' message appear?	<ul style="list-style-type: none"> <li>• The signal cable between PC and product is not connected. Check the signal cable.</li> <li>• Press the INPUT menu in the remote Control to check the input signal.</li> </ul>

## 'Unknown Product' message appears when the product is connected.

Problem	Resolution
Did you install the driver?	<ul style="list-style-type: none"> <li>• See if the plug&amp;play function is supported by referring to the video card user manual.</li> </ul>

## 'Key Lock On' message appears.

Problem	Resolution
The Key Lock On message appears when pressing the SETTINGS button.	<ul style="list-style-type: none"> <li>• The Lock function prevents the OSD settings from being changed inadvertently. To release the lock, go to Menu and Option and disable the Key Lock option.</li> </ul>

**The screen image looks abnormal.**

Problem	Resolution
Is the screen position wrong?	<ul style="list-style-type: none"> <li>• D-Sub analog signal - Press the "AUTO" button in the remote control to automatically select the optimal screen status that fits into the current mode. If adjustment is not satisfactory, select [PICTURE] - [Screen] - [Position] in OSD menu.</li> <li>• See if the video card resolution and frequency are supported by the product. If the frequency is out of range, set to the recommended resolution in the Control Panel "Display" Setting menu.</li> </ul>
Do thin lines appear on the background screen?	<ul style="list-style-type: none"> <li>• D-Sub analog signal - Press the "AUTO" button in the remote control to automatically select an optimal screen status that fits into the current mode. If adjustment is not satisfactory, select [PICTURE] - [Screen] - [Size] in OSD menu.</li> </ul>
Horizontal noise appears or the characters look blurred.	<ul style="list-style-type: none"> <li>• D-Sub analog signal - Press the "AUTO" button in the remote control to automatically select an optimal screen status that fits into the current mode. If adjustment is not satisfactory, select [PICTURE] - [Screen] - [Phase] in OSD menu.</li> </ul>
The screen is displayed abnormally.	<ul style="list-style-type: none"> <li>• The proper input signal is not connected to the signal port. Connect the signal cable that matches with the source input signal.</li> </ul>

**After-image appears on the product.**

Problem	Resolution
After-image appears when the product is turned off.	<ul style="list-style-type: none"> <li>• If you use a fixed image for a long time, the pixels may be damaged quickly. Use the screen-saver function.</li> </ul>

**PRECAUTIONS TO TAKE TO PREVENT IMAGE RETENTION**

- If a static image is displayed for an extended period of time, the screen may be damaged and the image retention can last for a long time or could be permanent. Damage resulting from long-term static images is not covered by the product warranty.
- Do not display a static image on the screen for more than two hour. Displaying images in a 4:3 aspect ratio for an extended period of time may cause image retention around the border of the screen. Most third-party products have the same issue and this will not be accepted as a cause for refund or exchange.

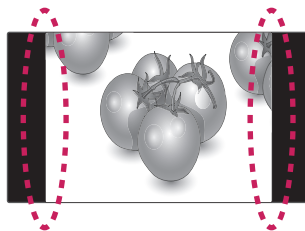

**The audio function does not work.**

Problem	Resolution
No sound?	<ul style="list-style-type: none"> <li>• See if the audio cable is connected properly.</li> <li>• Adjust the volume.</li> <li>• See if the sound is set properly.</li> </ul>
Sound is too dull.	<ul style="list-style-type: none"> <li>• Adjust the Clear Voice II, Treble and Bass appropriately.</li> </ul>
Sound is too low.	<ul style="list-style-type: none"> <li>• Adjust the volume.</li> </ul>

**Screen color is abnormal.**

Problem	Resolution
Screen has poor color resolution (16 colors).	<ul style="list-style-type: none"> <li>• Set the number of colors to more than 24 bits (true color) Select Control Panel - Display - Settings - Color Table menu in Windows.</li> </ul>
Screen color is unstable or mono-colored.	<ul style="list-style-type: none"> <li>• Check the connection status of the signal cable. Or, re-insert the PC video card.</li> </ul>
Do black spots appear on the screen?	<ul style="list-style-type: none"> <li>• Several pixels (red, green, white or black color) may appear on the screen, which can be attributable to the unique characteristics of the LCD panel. It is not a malfunction of the LCD.</li> </ul>
When I set Input Label to PC in the Input List, some letters are displayed with a different color than the original color.	<ul style="list-style-type: none"> <li>• For Windows 7, go to Start -&gt; Control Panel -&gt; Appearance and Personalization -&gt; Font and select Adjust ClearType text.</li> <li>* If you are using a specific graphic card that supports the UHD resolution, the problem may not be solved due to compatibility issues.</li> </ul>

**The operation does not work normally.**

Problem	Resolution
The power suddenly turned off.	<ul style="list-style-type: none"> <li>• Is the sleep timer set?</li> <li>• Check the power control settings. Power interrupted</li> </ul>

**I have a problem with touch response.**

Problem	Resolution
Touch does not respond.	<ul style="list-style-type: none"> <li>• Check the USB cable connection.               <ul style="list-style-type: none"> <li>- This may occur when the USB cable between PC and monitor is not connected. Check the USB cable and make it firmly connected.</li> </ul> </li> <li>* Check the connection on Windows 7               <ul style="list-style-type: none"> <li>Control Panel &gt; System and Security &gt; System</li> </ul> </li> <li>- Check the number of touch-points supported under Pen and Touch.</li> <li>• Check the PC power.               <ul style="list-style-type: none"> <li>- This may occur when the PC is powered off. Make sure that your PC's power cord is firmly plugged into a power outlet.</li> </ul> </li> <li>• Restart your PC.               <ul style="list-style-type: none"> <li>- Touch may not respond when the system is down due to the unstable network. Reconnect the LAN cable or restart your PC.</li> </ul> </li> <li>• Check the signal cable connection.               <ul style="list-style-type: none"> <li>- If your PC and monitor are not connected using a signal cable, touch does not respond. Check the signal cable connection.</li> </ul> </li> <li>• Check the monitor power.               <ul style="list-style-type: none"> <li>- Touch may not respond when the monitor is powered off. Check if the power indicator turns red and the screen is displayed.</li> </ul> </li> <li>• Check if the screen is currently on.</li> </ul>
The location of a touch does not correspond to the touch coordinates.	<ul style="list-style-type: none"> <li>• Change your tablet PC settings (Windows 7).               <ul style="list-style-type: none"> <li>- This may occur when the touch screen is not calibrated properly. Control Panel &gt; Hardware and Sound &gt; Tablet PC Settings &gt; Display &gt; Display options &gt; Calibrate or Reset</li> </ul> </li> <li>* For information about gestures and settings on Windows 7, refer to the Windows Help.</li> </ul>
A touch is applied to a monitor other than the one I intended.	<ul style="list-style-type: none"> <li>• Set the monitor as the default monitor.               <ul style="list-style-type: none"> <li>- This may occur if the monitor is not set as the default monitor when you are using multiple monitors. Go to Control Panel &gt; Display &gt; Settings tab &gt; Select the monitor &gt; Use this device as the primary monitor (U) &gt; Apply (A)</li> </ul> </li> <li>• Change your tablet PC settings (Windows 7).               <ul style="list-style-type: none"> <li>- This may occur when the touch screen is not calibrated properly. Go to Control Panel &gt; Hardware and Sound &gt; Tablet PC Settings &gt; Display &gt; Display options &gt; Calibrate or Reset</li> </ul> </li> </ul>

Problem	Resolution
I cannot use 10 touch points in Windows 7.	<ul style="list-style-type: none"><li>• Make sure that you use a content that supports up to 10 touch points.<ul style="list-style-type: none"><li>- The content played (e.g. Flash Player, Paint, etc.) may not support 10 touch points.</li></ul></li><li>• Remove the USB cable and connect it again in 10 seconds.</li><li>• Run the content (e.g. Flash Player, Paint, etc.) again.</li><li>• Restart your PC.</li><li>• If the gap between two touch points is 20 mm or less, the touch error may occur.</li><li>• On the edge of the touch screen, 10 touch points may work unstably.</li></ul>



# SPECIFICATIONS

LCD Panel	Screen Type	2134.62 mm Wide TFT (Thin Film Transistor) LCD (Liquid Crystal Display) Panel. Visible diagonal size : 2134.62 mm
	Pixel Pitch	0.4845 mm (H) x 0.4845 mm (V)
Video Signal	Max. Resolution	RGB, DVI-D: 1920 X 1080 @60 Hz HDMI, Display Port: 3840 X 2160 @30 Hz - It may not be supported depending on the OS or video card type.
	Recommended Resolution	RGB, DVI-D: 1920 X 1080 @60 Hz HDMI, Display Port: 3840 X 2160 @30 Hz - It may not be supported depending on the OS or video card type.
	Horizontal Frequency	RGB: 30 kHz to 83 kHz HDMI,DVI-D, Display Port: 30 kHz to 83 kHz
	Vertical Frequency	RGB: 56 Hz to 75 Hz HDMI,DVI-D, Display Port: 56 Hz to 60 Hz
	Synchronization Type	Separate Sync, Composite Sync, Digital
Input Connector	15-pin D-Sub, HDMI, DVI-D, Composite (AV), Display Port, RS-232C, LAN, USB, Audio, TOUCH USB	
Power	Power Rating	AC 100-240 V~ 50/60 Hz 5.7 A
	Power Consumption	On Mode: 350 W Typ. Sleep Mode (RGB): ≤ 1.5 W Sleep Mode (HDMI, DVI-D, Display Port) : ≤ 1.5 W (Set Only) / ≤ 2 W (With External Device) Off Mode : ≤ 0.5 W
Environmental conditions	Operating Temperature	0 °C to 40 °C
	Operating Humidity	10 % to 80 %
	Storage Temperature	-20 °C to 60 °C
	Storage Humidity	5 % to 95 %
Dimensions (Width x Height x Depth) / Weight		
	1923.4 mm x 1109.4 mm x 101 mm / 102.6 kg	

**\* Touch Screen**

OS (Operating System)	Windows 7	10 Points
	Space between touches : at least 20 mm or more	

**\* Applicable only for models that support the speakers**

Audio	RMS Audio Output	10 W + 10 W (R + L)
	Input Sensitivity	0.7 Vrms
	Speaker Impedance	8 $\Omega$

Product specifications shown above may be changed without prior notice due to upgrade of product functions.

**RGB (PC) supported mode**

Resolution	Horizontal Frequency(kHz)	Vertical Frequency(Hz)
640 x 350	31.469	70.8
720 x 400	31.468	70.8
640 x 480	31.469	59.94
640 x 480	37.5	75
800 x 600	37.879	60.317
800 x 600	46.875	75
832 x 624	49.725	74.55
1024 x 768	48.363	60
1024 x 768	60.123	75.029
1280 x 768	47.7	60
1280 x 960	74.479	75
1360 x 768	47.72	59.799
1280 x 1024	63.981	60.02
1280 x 1024	79.98	75.02
1920 x 1080	67.5	60

**HDMI/Display Port/SuperSign (DTV) supported mode**

Resolution	Horizontal Frequency(kHz)	Vertical Frequency(Hz)
640 x 480	31.469	59.94
800 x 600	37.879	60.317
1024 x 768	48.363	60
1280 x 720	44.772	59.855
1366 x 768	47.7	60
1152 x 864	53.783	59.959
1280 x 960	60	60
1280 x 1024	63.981	60.02
1920 x 1080	67.5	60
3840 x 2160	67.5	30

**DVI-D (PC) supported mode**

Resolution	Horizontal Frequency(kHz)	Vertical Frequency(Hz)
640 x 480	31.469	59.94
800 x 600	37.879	60.317
1024 x 768	48.363	60
1366 x 768	47.7	60
1152 x 864	53.783	59.959
1280 x 960	60	60
1280 x 1024	63.981	60.02
1920 x 1080	67.5	60

**! NOTE**

- Vertical frequency: To enable the user to watch the product display, screen image should be changed tens of times every second like a fluorescent lamp. The vertical frequency or refresh rate is the times of image display per second. The unit is Hz.
- Horizontal frequency: The horizontal interval is the time to display one vertical line. When 1 is divided by the horizontal interval, the number of horizontal lines displayed every second can be tabulated as the horizontal frequency. The unit is kHz.

**DTV Mode**

Resolution	HDMI/Display Port/ SuperSign (DTV)
480i	x
480p	o
576i	x
576p	o
720p	o
1080i	o
1080p	o
2160p	o

**Power Indicator**

Mode	Product
On Mode	Red
Sleep Mode	Amber
Off Mode	-

**NOTE**

- When the cable is connected to the HDMI or the display port, you can select the PC/DTV mode optionally. It is recommended you to set to the PC mode when connecting to PC; the DTV mode when connecting to DTV.

**Dimensions**

The illustrations in this manual may differ from the actual product and accessories. Please see the Mounting on a wall section for sizes of screws.

(Unit: mm)

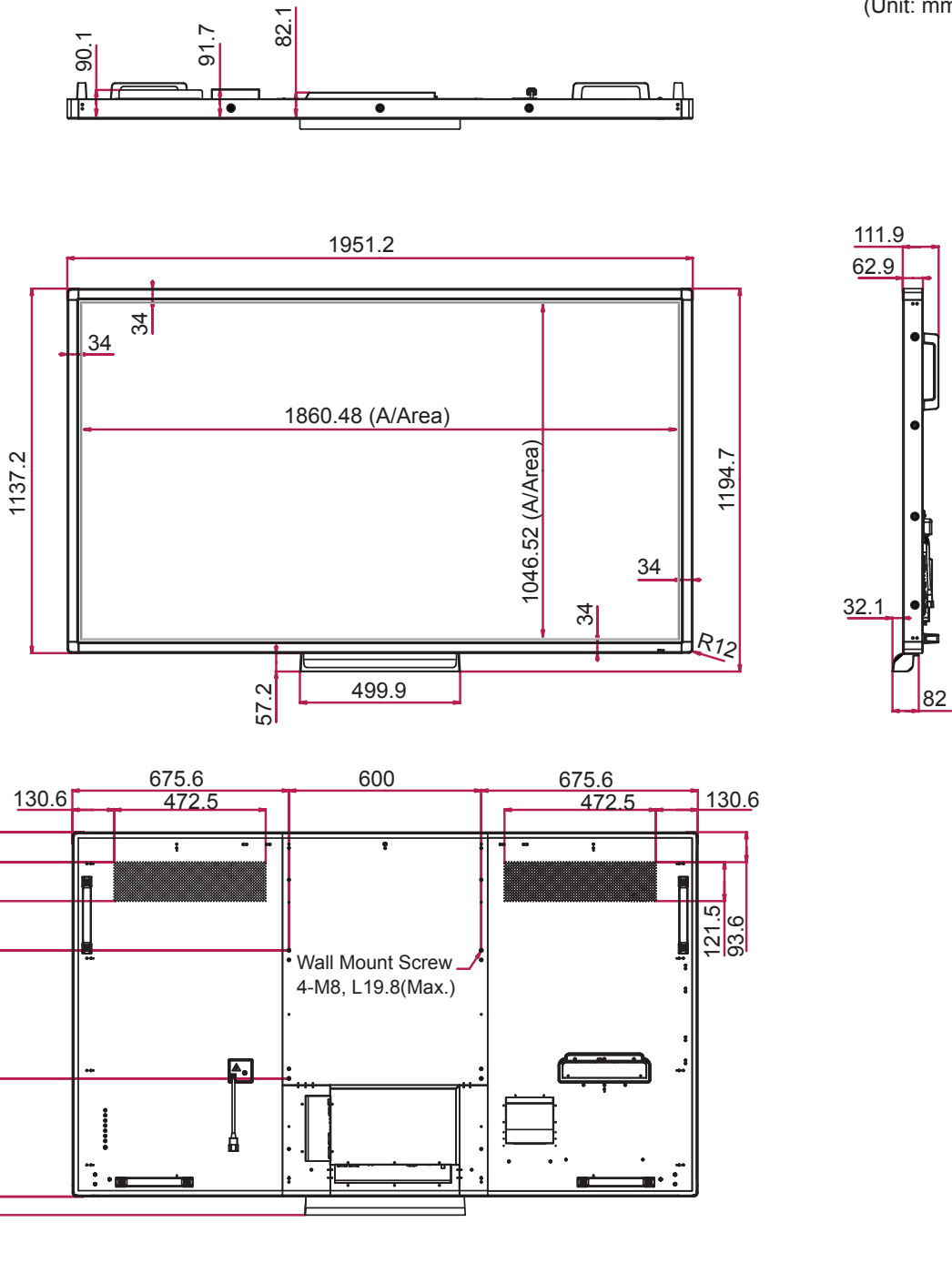

ENGLISH

Product specifications shown above may be changed without prior notice due to upgrade of product functions.

# IR CODES

- All models do not support the HDMI/USB function.
- Some key codes are not supported, depending on the model.

Code (Hexa)	Function	Note
08	⏻ Power	R/C BUTTON
0B	INPUT	R/C BUTTON
C4	MONITOR ON	R/C BUTTON
C5	MONITOR OFF	R/C BUTTON
95	ENERGY SAVING	R/C BUTTON
DC	3D	R/C BUTTON
10 to 19	Number Key 0 to 9	R/C BUTTON
32	1/a/A	R/C BUTTON
2F	CLEAR	R/C BUTTON
02	Volume  (+)	R/C BUTTON
03	Volume  (-)	R/C BUTTON
79	ARC	R/C BUTTON
99	AUTO	R/C BUTTON
09	MUTE	R/C BUTTON
E0	BRIGHTNESS  (Page UP)	R/C BUTTON
E1	BRIGHTNESS  (Page Down)	R/C BUTTON
4D	PSM	R/C BUTTON
AA	INFO ⓘ	R/C BUTTON
5F	W.BAL	R/C BUTTON
43	SETTINGS	R/C BUTTON
40	Up ▲	R/C BUTTON
41	Down ▼	R/C BUTTON
07	Left ◀	R/C BUTTON
06	Right ▶	R/C BUTTON
3F	S.MENU	R/C BUTTON
44	OK	R/C BUTTON
28	BACK	R/C BUTTON
5B	EXIT	R/C BUTTON
7E	 Simplink	R/C BUTTON
7B	TILE (Tile Mode)	R/C BUTTON
B1	■	R/C BUTTON
B0	▶	R/C BUTTON
BA		R/C BUTTON
8F	◀◀	R/C BUTTON
8E	▶▶	R/C BUTTON
72	Red Key (PICTURE ID ON)	R/C BUTTON
71	Green Key (PICTURE ID OFF)	R/C BUTTON
63	Yellow Key	R/C BUTTON
61	Blue Key	R/C BUTTON

# CONTROLLING THE MULTIPLE PRODUCT

- Use this method to connect several products to a single PC. You can control several products at a time by connecting them to a single PC.
- In the Option menu, Set ID must be between 1 and 255 without being duplicated.

## Connecting the Cable

Connect the RS-232C cable as shown in the picture.

- The RS-232C protocol is used for communication between the PC and product. You can turn the product on/off, select an input source or adjust the OSD menu from your PC.

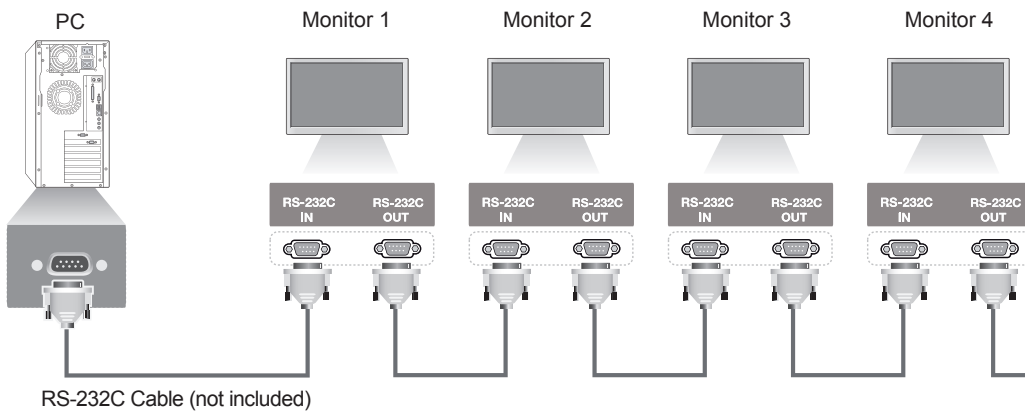

## RS-232C Configurations

### 7-Wire Configurations (Standard RS-232C cable)

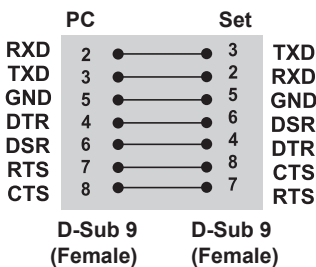

### 3-Wire Configurations (Not Standard)

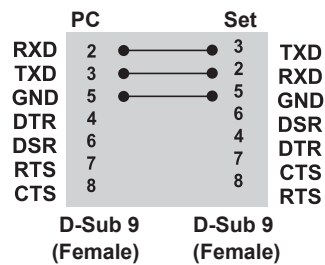

## Communication Parameter

- Baud Rate : 9600 buad Rate (UART)
- Data Length : 8 bit
- Parity Bit : None
- Stop Bit : 1bit
- Flow Control : None
- Communication Code : ASCII code
- Use a crossed (reverse) cable

## Command Reference List

		COMMAND		DATA
		1	2	
01	Power	k	a	00H to 01H
02	Aspect Ratio	k	c	01H to 1FH
03	Screen Mute	k	d	00H to 01H
04	Volume Mute	k	e	00H to 01H
05	Volume Control	k	f	00H to 64H
06	Contrast	k	g	00H to 64H
07	Brightness	k	h	00H to 64H
08	Color	k	i	00H to 64H
09	Tint	k	j	00H to 64H
10	Sharpness	k	k	00H to 32H
11	OSD Select	k	l	00H to 01H
12	Remote Lock/ key Lock	k	m	00H to 01H
13	Audio Balance	k	t	00H to 64H
14	Abnormal state	k	z	FFH
15	White Balance Red Gain	j	m	00H to FEH
16	White Balance Green Gain	j	n	00H to FEH
17	White Balance Blue Gain	j	o	00H to FEH
18	ISM Method	j	p	20H, 08H
19	Energy Saving	j	q	00H to 05H
20	Auto configuration	j	u	01H
21	Remote Key	m	c	Refer to Remote Key code
22	Backlight	m	g	00H to 64H
23	Fail Over Select	m	i	00H to 02H
24	Fail Over Input Select	m	j	Refer 'Fail Over Input Select'
25	Automatic Standby	m	n	00H to 01H
26	PC Power Control	d	t	00H to 01H
27	PC Power	d	s	00H to 01H
28	Picture mode (PSM)	d	x	00H to 07H, 10H
29	Sound mode	d	y	01H to 07H
30	Elapsed time return	d	l	FFH
31	Temperature value	d	n	FFH
32	Speaker	d	v	00H to 01H
33	Sleep Time	f	f	00H to 08H
34	Auto Sleep	f	g	00H to 01H
35	Power On Delay	f	h	00H to 64H
36	Language	f	i	00H to 12H
37	DPM Select	f	j	00H to 01H
38	Reset	f	k	00H to 02H
39	Power Indicator(Standby Light)	f	o	00H to 01H
40	Power Indicator(Power Light)	f	p	00H to 01H
41	Serial no.	f	y	FFH



		COMMAND		DATA
		1	2	
42	S / W Version	f	z	FFH
43	Time 1(Years/ Months/ Days)	f	a	Refer to 'Time 1'
44	Time 2(Hours/ Minutes/Seconds)	f	x	Refer to 'Time 2'
45	Off Time Schedule	f	c	00H to 01H
46	On Time Schedule	f	b	00H to 01H
47	Off Timer(Repeat mode/ Time)	f	e	Refer to 'Off Timer'
48	On Timer(Repeat Mode/ Time)	f	d	Refer to 'On Timer'
49	On Timer Input	f	u	Refer to 'On Timer Input'
50	H Position	f	q	00H to 64H
51	V Position	f	r	00H to 64H
52	H Size	f	s	00H to 64H
53	Input Select	x	b	20H to D0H
54	Color Temperature	x	u	00H to 64H

- Note: When using the product with a USB DivX player, all commands except for Power (k a), Key (m c), Abnormal state (k z), Elapsed time return (d l), Temperature value (d n), Serial no.Check (f y) and S/W Version (f z) are not executed and handled as errors.

## Transmission/ Receiving protocol

### Transmission

[Command1][Command2][ ][Set ID][ ][Data][Cr]

- \* [Command 1]: First command. (k, j, m, d, f, x)
- \* [Command 2]: Second command.(a to z)
- \* [Set ID]: Set up the Set ID number of product.  
range : 01H to 63H. by setting '0', server can control all products.
- \* In case of operating with more than 2 sets using set ID as '0' at the same time, it should not be checked the ack message. Because all sets will send the ack message, so it's impossible the check the whole ack messages.
- \* [DATA]: To transmit command data.  
Transmit 'FF' data to read status of command.
- \* [Cr]: Carriage Return (ASCII code '0 x 0 D')
- \* [ ]: ASCII code Space (0 x 20)

### OK Acknowledgement

[Command2][ ][Set ID][ ][OK][Data][x]

- \* The Product transmits ACK (acknowledgement) based on this format when receiving normal data. At this time, if the data is data read mode, it indicates present status data. If the data is data write mode, it returns the data of the PC computer.
- \* Note : In this mode, display will send the acknowledgement after power on processing completion. There might be a time delay between command and acknowledgement.
- \* No acknowledgement signal will be sent from display, if Set ID in transmission signal is set to '00'(=0x00).

### Error Acknowledgement

[Command2][ ][Set ID][ ][NG][Data][x]

- \* If there is error, it returns NG

**\* Real data mapping**

Hexadecimal Num. (Setting Value)	Decimal Num. (Real Value)
0	0
A	10
F	15
10	16
20	32
64	100
FE	254
FF	255

**01. Power(Command: k, a)**

To control Power On/Off of the set.

Transmission  
[k][a][ ][Set ID][ ][Data][Cr]

Data

00: Power Off

01: Power On

Acknowledgement  
[a][ ][Set ID][ ][OK/NG][Data][x]

- \* The normal acknowledgement signal returns after the power of the set is turned on completely.
- \* There might be a time delay between the transmission and acknowledgement signals.

**02. Aspect Ratio(Command: k, c)**

To adjust the screen format.

You can also adjust the screen format using the ARC(Aspect Ratio Control) button on remote control or in the Screen menu.

Transmission  
[k][c][ ][Set ID][ ][Data][Cr]

Data

01: Normal Screen(4:3)

02: Wide Scran(16:9)

04: Zoom(AV, Component, HDMI/ Display Port DTV)

06: Original

09: Just Scan(HDMI1/ HDMI2/ DVI/ Display Port -DTV)

\* Available only with 720p or higher.

10 to 1F: Cinema Zoom 1 to 16(AV, HDMI1/HDMI2/ DVI/Display Port -DTV)

Acknowledgement  
[c][ ][Set ID][ ][OK/NG][Data][x]

**03. Screen Mute(Command: k, d)**

To select screen mute on / off.

Transmission  
[k][d][ ][Set ID][ ][Data][Cr]

Data

00: Screen on

01: Screen off

Acknowledgement  
[d][ ][Set ID][ ][OK/NG][Data][x]

**04. Volume Mute(Command: k, e)**

To control On/Off of the Volume Mute.

Transmission  
[k][e][ ][Set ID][ ][Data][Cr]

Data

00: Volume Mute On (Volume Off)

01: Volume Mute Off (Volume On)

Acknowledgement  
[e][ ][Set ID][ ][OK/NG][Data][x]

**05. Volume Control(Command: k, f)**

To adjust Volume.

Transmission  
[k][f][ ][Set ID][ ][Data][Cr]

Data

Min. 00H to Max. 64H : 0~100

\* Refer to 'Real data mapping'.

Acknowledgement  
[f][ ][Set ID][ ][OK/NG][Data][x]

**06. Contrast(Command: k, g)**

To adjust screen contrast.

You can also adjust the contrast in the Picture menu.

Transmission

[k][g][ ][Set ID][ ][Data][Cr]

Data

Min. 00H to Max. 64H : 0~100

\* Refer to 'Real data mapping'.

Acknowledgement

[g][ ][Set ID][ ][OK/NG][Data][x]

**07. Brightness(Command: k, h)**

To adjust screen brightness.

You can also adjust the brightness in the Picture menu.

Transmission

[k][h][ ][Set ID][ ][Data][Cr]

Data

Min. 00H to Max. 64H : 0~100

\* Refer to 'Real data mapping'.

Acknowledgement

[h][ ][Set ID][ ][OK/NG][Data][x]

**08. Color(Command: k, i)**

To adjust the screen color.

You can also adjust the color in the Picture menu.

Transmission

[k][i][ ][Set ID][ ][Data][Cr]

Data

Min. 00H to Max. 64H : 0~100

\* Refer to 'Real data mapping'.

Acknowledgement

[i][ ][Set ID][ ][OK/NG][Data][x]

**09. Tint(Command: k, j)**

To adjust the screen tint.

You can also adjust the tint in the Picture menu.

Transmission

[k][j][ ][Set ID][ ][Data][Cr]

Data

Min. 00H to Max. 64H

00H: Step R50

64H: Step G50

\* Refer to 'Real data mapping'.

Acknowledgement

[j][ ][Set ID][ ][OK/NG][Data][x]

**10. Sharpness(Command: k, k)**

To adjust the screen Sharpness.

You can also adjust the sharpness in the Picture menu.

Transmission

[k][k][ ][Set ID][ ][Data][Cr]

Data

Min. 00H to Max. 32H : 0~50

\* Refer to 'Real data mapping'.

Acknowledgement

[k][ ][Set ID][ ][OK/NG][Data][x]

**11. OSD Select(Command: k, l)**

To control OSD on/off to the set.

Transmission

[k][l][ ][Set ID][ ][Data][Cr]

Data

00: OSD Off

01: OSD On

Acknowledgement

[l][ ][Set ID][ ][OK/NG][Data][x]

**12. Remote Lock /Key Lock(Command: k, m)**

To control Remote Lock on/off to the set.

This function, when controlling RS-232C, locks the remote control and the local keys.

**Transmission**

[k][m][ ][Set ID][ ][Data][Cr]

Data

00: Off

01: On

**Acknowledgement**

[m][ ][Set ID][ ][OK/NG][Data][x]

**13. Balance(Command: k, t)**

To adjust the sound balance.

**Transmission**

[k][t][ ][Set ID][ ][Data][Cr]

Data

Min. 00H to Max. 64H

00H: Step L50

64H: Step R50

\* Refer to 'Real data mapping'.

**Acknowledgement**

[t][ ][Set ID][ ][OK/NG][Data][x]

**14. Abnormal state(Command: k, z)**

Used to Read the power off status when Stand-by mode.

**Transmission**

[k][z][ ][Set ID][ ][Data][Cr]

Data

FF: Check the status

**Acknowledgement**

[z][ ][Set ID][ ][OK/NG][Data][x]

Data

00: Normal (Power on and signal exist)

01: No signal (Power on)

02: Turn the monitor off by Remote Control

03: Turn the monitor off by **Sleep Timer** function

04: Turn the monitor off by **RS-232C** function

08: Turn the monitor off by **Off Time** function

09: Turn the monitor off by **Auto Off** function

**15. White Balance Red Gain(Command: j, m)**

To adjust white balance red gain.

**Transmission**

[j][m][ ][Set ID][ ][Data][Cr]

Data

00~FE: Red gain 0~254

**Acknowledgement**

[m][ ][Set ID][ ][OK/NG][Data][x]

**16. White Balance Green Gain(Command: j, n)**

To adjust white balance green gain.

**Transmission**

[j][n][ ][Set ID][ ][Data][Cr]

Data

00~FE: Green gain 0~254

**Acknowledgement**

[n][ ][Set ID][ ][OK/NG][Data][x]

**17. White Balance Blue Gain(Command: j, o)**

To adjust white balance blue gain.

**Transmission**

[j][o][ ][Set ID][ ][Data][Cr]

Data

00~FE: Blue gain 0~254

**Acknowledgement**

[o][ ][Set ID][ ][OK/NG][Data][x]

**18. ISM Method(Command: j, p)**

Used to select the afterimage preventing function.

Transmission

[j][p][ ][Set ID][ ][Data][Cr]

Data

20: Color Wash

08: Normal

Acknowledgement

[p][ ][Set ID][ ][OK/NG][Data][x]

**19. Energy Saving(Command: j, q)**

To reduce the power consumption of the Monitor.

Transmission

[j][q][ ][Set ID][ ][Data][Cr]

Data

00: Off

01: Minimum

02: Medium

03: Maximum

05: Screen Off

Acknowledgement

[q][ ][Set ID][ ][OK/NG][Data][x]

**20. Auto Config.(Command: j, u)**

To adjust picture position and minimize image shaking. Automatically.

\* Only applies to RGB(PC) mode.

Transmission

[j][u][ ][Set ID][ ][Data][Cr]

Data

01: To set

Acknowledgement

[u][ ][Set ID][ ][OK/NG][Data][x]

**21. Remote Key(Command: m, c)**

To send IR remote key code.

Transmission

[m][c][ ][Set ID][ ][Data][Cr]

Data: Refer to 'IR CODES'.

Acknowledgement

[c][ ][Set ID][ ][OK/NG][Data][x]

**22. Backlight(Command: m, g)**

To adjust light of the Backlight.

Transmission

[m][g][ ][Set ID][ ][Data][Cr]

Data

Min. 00H to Max. 64H : 0~100

\* Refer to 'Real data mapping'.

Acknowledgement

[g][ ][Set ID][ ][OK/NG][Data][x]

\* If Energy Saving is set to Auto/ Maximum/ Screen off the Backlight function is disabled.

**23. Fail Over Select(Command: m, i)**

To select Fail Over mode.

Transmission

[m][i][ ][Set ID][ ][Data][Cr]

Data

00: Off

01: Auto

02: Manual

Acknowledgement

[i][ ][Set ID][ ][OK/NG][Data][x]

**24. Fail Over Input Select(Command: m, j)**

To select fail over mode.

\* Only available in Fail Over is Manual mode.

**Transmission**

[m][j][ ][Set ID][ ][Data1][ ][Data2][ ][Data3][ ][Data4][ ][Data5][Cr]

Data1~5(Priority 1~5)

60: RGB

70: DVI-D

90: HDMI1

91: HDMI2

C0: Display Port

\* Use 0x70 as data for DVI-D input, 0x90 as data for HDMI1 input, 0x91 as data for HDMI2 input, 0xC0 as data for DisplayPort input, regardless their input labels.

**Acknowledgement**

[j][ ][Set ID][ ][OK/NG][Data1][Data2][Data3][Data4][Data5][x]

**25. Automatic Standby(Command: m, n)**

To set the Automatic Standby function.

**Transmission**

[m][n][ ][Set ID][ ][Data][Cr]

Data

00: Off (The Automatic Standby function is not used)

01: 4 hours (The set is turned off after four hours)

**Acknowledgement**

[n][ ][Set ID][ ][OK/NG][Data][x]

**26. PC Power Control(Command: d, t)**

To control the PC power if the PC and the monitor are synchronized.

**Transmission**

[d][t][ ][Set ID][ ][Data][Cr]

Data

00: Synchronized (When the monitor is off, the PC is also turned off.)

01: Not synchronized (The monitor is off but the PC is on.)

**Acknowledgement**

[t][ ][Set ID][ ][OK/NG][Data][x]

**27. PC Power(Command: d, s)**

To control the PC power when the PC and the monitor are not synchronized.

**Transmission**

[d][s][ ][Set ID][ ][Data][Cr]

Data

00: PC is turned off.

01: PC is turned on.

**Acknowledgement**

[s][ ][Set ID][ ][OK/NG][Data][x]

**28. Picture Mode(Command: d, x)**

To adjust the picture mode.

**Transmission**

[d][x][ ][Set ID][ ][Data][Cr]

Data Structure

Data (Hex)	Mode
00	Vivid
01	Standard
02	Cinema
04	Game
05	Expert1
06	Expert2
10	Touch

\* If you select Cinema, Expert1, or Expert2, you cannot adjust Color Temp.

\* The touch features only work with the 84WT70 model.

**Acknowledgement**

[x][ ][Set ID][ ][OK/NG][Data][x]

**29. Sound Mode(Command: d, y)**

To adjust the Sound mode.

Transmission  
[d][y][ ][Set ID][ ][Data][Cr]

Data Structure

Data(Hex)	Mode
01	Standard
02	Music
03	Cinema
04	Sport
05	Game
06	Vivid
07	User Setting

Acknowledgement  
[y][ ][Set ID][ ][OK/NG][Data][x]

**30. Elapsed time return(Command: d, l)**

To read the elapsed time.

Transmission  
[d][l][ ][Set ID][ ][Data][Cr]

Data

FF: Read the elapsed time

Acknowledgement  
[l][ ][Set ID][ ][OK/NG][Data][x]

**31. Temperature value(Command: d, n)**

To read the inside temperature value.

Transmission  
[d][n][ ][Set ID][ ][Data][Cr]

Data

FF: Check the temperature

Acknowledgement  
[n][ ][Set ID][ ][OK/NG][Data][x]

**32. Speaker(Command: d, v)**

Turn the speaker on or off.

Transmission  
[d][v][ ][Set ID][ ][Data][Cr]

Data

00: Off

01: On

Acknowledgement  
[v][ ][Set ID][ ][OK/NG][Data][x]

**33. Sleep Timer(Command: f, f)**

Set Sleep Timer.

Transmission  
[f][f][ ][Set ID][ ][Data][Cr]

Data

00: Off

01: 10 minutes

02: 20 minutes

03: 30 minutes

04: 60 minutes

05: 90 minutes

06: 120 minutes

07: 180 minutes

08: 240 minutes

Acknowledgement  
[f][ ][Set ID][ ][OK/NG][Data][x]

**34. Auto Sleep(Command: f, g)**

To set Auto Sleep.

Transmission  
[f][g][ ][Set ID][ ][Data][Cr]

Data

00: Off (The Auto Off function is not used)

01: 15 min. (If there is no signal for 15 minutes, the set is turned off)

Acknowledgement  
[g][ ][Set ID][ ][OK/NG][Data][x]



**35. Power On Delay(Command: f, h)**

Set the schedule delay when the power is turned on (Unit: second).

Transmission  
[f][h][ ][Set ID][ ][Data][Cr]

Data

Min. 00H to Max. 64H : 0~100 seconds

\* Refer to 'Real data mapping'.

Acknowledgement  
[h][ ][Set ID][ ][OK/NG][Data][x]

**36. Language(Command: f, i)**

Set the OSD language.

Transmission  
[f][i][ ][Set ID][ ][Data][Cr]

Data

00: Czech

01: Danish

02: German

03: English

04: Spanish(EU)

05: Greek

06: French

07: Italian

08: Dutch

09: Norwegian

0a: Portuguese(EU)

0b: Portuguese(Brazil)

0c: Russian

0d: Finnish

0e: Swedish

0f: Korean

10: Simplified Chinese

11: Japanese

12: Traditional Chinese

Acknowledgement  
[i][ ][Set ID][ ][OK/NG][Data][x]

**37. DPM Select(Command: f, j)**

Set the DPM (Display Power Management) function.

Transmission  
[f][j][ ][Set ID][ ][Data][Cr]

Data

00: Off

01: On

Acknowledgement  
[j][ ][Set ID][ ][OK/NG][Data][x]

**38. Reset(Command: f, k)**

Execute the Picture, Screen and Factory Reset functions.

Transmission  
[f][k][ ][Set ID][ ][Data][Cr]

Data

00 : Picture Reset

(Reset the values set in the PICTURE menu.)

01 : Screen Reset

(Reset the values set in under the Screen option.)

02 : Factory Reset

(Reset the values set in the OPTION menu.)

03 : Audio Reset

(Reset the values set in the AUDIO menu.)

Acknowledgement  
[k][ ][Set ID][ ][OK/NG][Data][x]

**39. Power Indicator(Standby Light)(Command: f, o)**

To set the Standby Light.

Transmission  
[f][o][ ][Set ID][ ][Data][Cr]

Data

00: Off

01: On

Acknowledgement  
[o][ ][Set ID][ ][OK/NG][Data][x]

**40. Power Indicator(Power Light)(Command: f, p)**

To set the Power Light.

Transmission  
[f][p][ ][Set ID][ ][Data][Cr]

Data

00: Off

01: On

Acknowledgement  
[p][ ][Set ID][ ][OK/NG][Data][x]

**41. Serial no.Check(Command: f, y)**

Check the Serial no.

Transmission  
[f][y][ ][Set ID][ ][Data][Cr]

Data

FF: Check the Serial no.

Acknowledgement  
[y][ ][Set ID][ ][OK/NG][Data1] to [Data13][x]

**42. S/W Version(Command: f, z)**

Check the software version.

Transmission  
[f][z][ ][Set ID][ ][Data][Cr]

Data

FF: Check the software version.

Acknowledgement  
[z][ ][Set ID][ ][OK/NG][Data][x]

**43. Time 1(Year/ Month/ Day)(Command: f, a)**

To set the Time 1(Year/ Month/ Day) values.

Transmission  
[f][a][ ][Set ID][ ][Data1][ ][Data2][ ][Data3][Cr]

Data1

00 to 1E: 2010 to 2040

Data2

01 to 0C: January to December

Data3

01 to 1F: 1st to 31st

\* Enter "fa [Set ID] ff" for checking Time 1 values.

Acknowledgement  
[a][ ][Set ID][ ][OK/NG][Data1][Data2][Data3][x]

**44. Time 2(Hours/Minutes/Seconds)(Command: f, x)**

To set Time 2 (Hours/ Minutes/ Seconds).

Transmission  
[f][x][ ][Set ID][ ][Data1][ ][Data2][ ][Data3][Cr]

Data1

00 - 17: 00 - 23 hours

Data2

00 - 3B: 00 - 59 minutes

Data3

00 - 3B: 00 - 59 seconds

\* To check the settings of the Time 2, enter "fx [Set ID] ff".

\*\* If the Time 1 is not set, this command does not work.

Acknowledgement  
[x][ ][Set ID][ ][OK/NG][Data1][Data2][Data3][x]

**45. Off Time Schedule(Command: f, c)**

To set whether to activate the Off Time schedule.

Transmission  
[f][c][ ][Set ID][ ][Data][Cr]

Data

00: Off

01: On

Acknowledgement  
[c][ ][Set ID][ ][OK/NG][Data][x]

**46. On Time schedule(Command: f, b)**

To set whether to activate the On Time schedule.

Transmission  
[f][b][ ][Set ID][ ][Data][Cr]

Data

00: Off

01: On

Acknowledgement  
[b][ ][Set ID][ ][OK/NG][Data][x]

**47. Off Timer(Repeat mode/Time)(Command: f, e)**

To set Off Time (Repeat mode/Time).

**Transmission**

[f][e][ ][Set ID][ ][Data1][ ][Data2][ ][Data3][Cr]

**Data1**

01: Once  
 02: Daily  
 03: Mon. - Fri.  
 04: Mon. - Sat.  
 05: Sat. - Sun.  
 06: Every Sunday  
 07: Every Monday  
 08: Every Tuesday  
 09: Every Wednesday  
 0A: Every Thursday  
 0B: Every Friday  
 0C: Every Saturday

**Data2**

00 - 17: 00 - 23 hours

**Data3**

00 - 3B: 00 - 59 minutes

\* If Time 1, 2 are not set, this command does not work.

\* Data 1 (07, 08, 09, 0A, 0B, 0C) is displayed as "Select day" on the OSD.

**Acknowledgement**

[e][ ][Set ID][ ][OK/NG][Data1][Data2][Data3][x]

To check Off Time (Repeat mode/Hours/Minutes).

**Transmission**

[f][e][ ][Set ID][ ][Data][ ][f][f][ ][f][f][Cr]

**Data1**

f1-f7: The first to the seventh index number of the Off Time list

**Acknowledgement**

[e][ ][Set ID][ ][OK/NG][Data1][Data2][Data3][Data4][x]

**Data1**

f1-f7: The first to the seventh index number of the Off Time list

**Data2**

01: Once  
 02: Daily  
 03: Mon. - Fri.  
 04: Mon. - Sat.  
 05: Sat. - Sun.  
 06: Every Sunday  
 07: Every Monday  
 08: Every Tuesday  
 09: Every Wednesday  
 0A: Every Thursday  
 0B: Every Friday  
 0C: Every Saturday

**Data3**

00 - 17: 00 - 23 hours

**Data4**

00 - 3B: 00 - 59 minutes

To delete Off Time (Repeat mode/Hours/Minutes).

**Transmission**

[f][e][ ][Set ID][ ][Data][ ][f][f][ ][f][f][Cr]

**Data**

e0: Delete all  
 e1 - e7: Delete from the first to the seventh index of the Off Time list

**Acknowledgement**

[e][ ][Set ID][ ][OK/NG][Data][ff][ff][x]

**Data**

e0: Delete all  
 e1 - e7: Delete from the first to the seventh index of the Off Time list

**48. On Timer(Repeat mode/Time)(Command: f, d)**

To set On Time (Repeat mode/Time).

**Transmission**

[f][d][ ][Set ID][ ][Data1][ ][Data2][ ][Data3][Cr]

**Data1**

01: Once  
 02: Daily  
 03: Mon. - Fri.  
 04: Mon. - Sat.  
 05: Sat. - Sun.  
 06: Every Sunday  
 07: Every Monday  
 08: Every Tuesday  
 09: Every Wednesday  
 0A: Every Thursday  
 0B: Every Friday  
 0C: Every Saturday

**Data2**

00 - 17: 00 - 23 hours

**Data3**

00 - 3B: 00 - 59 minutes

\* If Time 1, 2 are not set, this command does not work.

\* Data 1 (07, 08, 09, 0A, 0B, 0C) is displayed as "Select day" on the OSD.

**Acknowledgement**

[d][ ][Set ID][ ][OK/NG][Data1][Data2][Data3][x]

To check On Time (Repeat mode/Hours/Minutes).

**Transmission**

[f][d][ ][Set ID][ ][Data][ ][f][f][ ][f][f][Cr]

**Data1**

f1-f7: The first to the seventh index number of the On Time list

**Acknowledgement**

[d][ ][Set ID][ ][OK/NG][Data1][Data2][Data3][Data4][x]

**Data1**

f1-f7: The first to the seventh index number of the On Time list

**Data2**

01: Once  
 02: Daily  
 03: Mon. - Fri.  
 04: Mon. - Sat.  
 05: Sat. - Sun.  
 06: Every Sunday  
 07: Every Monday  
 08: Every Tuesday  
 09: Every Wednesday  
 0A: Every Thursday  
 0B: Every Friday  
 0C: Every Saturday

**Data3**

00 - 17: 00 - 23 hours

**Data4**

00 - 3B: 00 - 59 minutes

To delete On Time (Repeat mode/Hours/Minutes).

**Transmission**

[f][d][ ][Set ID][ ][Data][ ][f][f][ ][f][f][Cr]

**Data**

e0: Delete all  
 e1 - e7: Delete from the first to the seventh index of the Off Time list

**Acknowledgement**

[d][ ][Set ID][ ][OK/NG][Data][ff][ff][x]

**Data**

e0: Delete all  
 e1 - e7: Delete from the first to the seventh index of the On Time list

**49. On Timer Input(Command: f, u)**

Select the video input when using On Timer.

**Transmission**  
[f][u][ ][Set ID][ ][Data][Cr]

**Data**  
20: AV  
60: RGB  
70: DVI-D  
90: HDMI1  
91: HDMI2  
C0: Display Port  
B0: SuperSign

\* If the Time 1, 2, and On Time (Repeat mode/Time) are not set, this command does not work.

\* To set the On Time schedule correctly, the On Timer (Repeat mode/Time) command must be executed prior to this command.

**Acknowledgement**  
[u][ ][Set ID][ ][OK/NG][Data][x]

To check the On Timer Input settings.

**Transmission**  
[f][u][ ][Set ID][ ][Data][ ][f][f][Cr]

**Data1**  
f1-f7: The first to the seventh index number of the On Time Input list

**Acknowledgement**  
[u][ ][Set ID][ ][OK/NG][Data1][Data2]

**Data1**  
The first to the seventh index number of the On Time Input list  
**Data2**  
20: AV  
60: RGB  
70: DVI  
90: HDMI1  
91: HDMI2  
C0: Display Port  
B0: SuperSign

**50. H Position(Command: f, q)**

To set the horizontal position.

\* Only available when Tile Mode is off.

**Transmission**  
[f][q][ ][Set ID][ ][Data][Cr]

**Data**  
Min. 00H to Max. 64H: Min. -50 (Left) - Max. 50 (Right)  
\* Data input range may vary depending on the resolution.

**Acknowledgement**  
[q][ ][Set ID][ ][OK/NG][Data][x]

**51. V Position(Command: f, r)**

To set the vertical position of the screen.

\* This function is only available when there is RGB input signal.

**Transmission**  
[f][r][ ][Set ID][ ][Data][Cr]

**Data**  
Min. 00H to Max. 64H: Min. -50 (down) - Max. 50 (up)  
\* Data input range may vary depending on the resolution.

**Acknowledgement**  
[r][ ][Set ID][ ][OK/NG][Data][x]

**52. H Size(Command: f, s)**

To set the horizontal size of the screen.

\* This function is only available when there is RGB input signal.

**Transmission**  
[f][s][ ][Set ID][ ][Data][Cr]

**Data**  
Min. 00H to Max. 64H: Min. -50 (Zoom out) - Max. 50 (Zoom in)  
\* Data input range may vary depending on the resolution.

**Acknowledgement**  
[s][ ][Set ID][ ][OK/NG][Data][x]

**53. Input Select(Command: x, b)**

To select input source for the Set.

**Transmission**  
[x][b][ ][Set ID][ ][Data][Cr]

**Data**  
20: AV  
60: RGB-PC  
70: DVI-D(PC)  
80: DVI-D  
90: HDMI1  
91: HDMI2  
A0: HDMI1(PC)  
A1: HDMI2(PC)  
B0: SuperSign(PC)  
C0: Display Port  
D0: Display Port(PC)

**Acknowledgement**  
[b][ ][Set ID][ ][OK/NG][Data][x]

**54. Color Temperature(Command: x, u)**

To adjust the screen color temperature.

Transmission

[x][u][ ][Set ID][ ][Data][Cr]

Data

00H to 64H: W50 - C50

\*W: Warm

\*C: Cool

Acknowledgement

[u][ ][Set ID][ ][OK/NG][Data][x]



Make sure to read the Safety Precautions before using the product.  
Keep the Owner's Manual(CD) in an accessible place for future reference.  
The model and serial number of the SET is located on the back and one side of the SET.  
Record it below should you ever need service.

MODEL \_\_\_\_\_

SERIAL \_\_\_\_\_

To obtain the source code under GPL, LGPL, MPL and other open source licenses, that is contained in this product, please visit <http://opensource.lge.com>.

In addition to the source code, all referred license terms, warranty disclaimers and copyright notices are available for download. LG Electronics will also provide open source code to you on CD-ROM for a charge covering the cost of performing such distribution (such as the cost of media, shipping and handling) upon email request to [opensource@lge.com](mailto:opensource@lge.com). This offer is valid for three (3) years from the date on which you purchased the product.

**WARNING** -This is a class A product. In a domestic environment this product may cause radio interference in which case the user may be required to take adequate measures.

Temporary noise is normal when powering ON or OFF this device.