



OWNER'S MANUAL

LIGHT OVEN “**SolarCUBE**™”

Please read this owner's manual thoroughly before operating. The manufacturers are not liable for any problems caused by the user's failure to observe these instructions.

MP9287NL



MFL30207328_02

www.lg.com

Contents

How the Microwave Function Works

Microwaves are a form of energy similar to radio and television waves and ordinary daylight. Normally, microwaves spread outwards as they travel through the atmosphere and disappear without effect. This ovens, however, have a magnetron which is designed to make use of the energy in microwaves. Electricity, supplied to the magnetron tube, is used to create microwave energy.

These microwaves enter the cooking area through openings inside the oven. A tray is located inside the oven. Microwaves cannot pass through metal walls of the oven, but they can penetrate such materials as glass, porcelain and paper, the materials out of which microwave-safe cooking dishes are constructed.

Microwaves do not heat cookware, though cooking vessels will eventually get hot from the heat generated by the food.

A very safe appliance

Your oven, SolarCUBE, is one of the safest of all home appliances. When the door is opened, the oven automatically stops producing microwaves. Microwave energy is converted completely to heat when it enters food, leaving no "left over" energy to harm you when you eat your food.

Contents	2
Important safety instructions	3 ~ 15
Precautions	16
Unpacking & Installing	17 ~ 18
Control Panel	19
Setting the Clock	20
Child Lock	21
Convection Preheat	22
Convection Cooking	23
Grill Cooking	24
Grill Combi Cooking	25
Convection Combi Cooking	26
Auto Cook	27 ~ 34
Defrost	35
Defrosting Guide	36
Ez Clean	37
Micro Power Cooking	38
Micro Power Level	39
Quick Start	40
More or Less Cooking	41
Microwave - safe Utensils	42
Food characteristics & Microwave cooking	43 ~ 44
Questions & Answers	45
Technical Specifications	46

Please keep for future reference. Read and follow all instructions before using your oven to prevent the risk of fire, electric shock, personal injury, or damage when using the oven. This guide do not cover all possible conditions that may occur. Always contact your service agent or manufacturer about problems that you do not understand.

Important Safety **Instructions**



This is the safety alert symbol. This symbol alerts you to potential hazards that can kill or hurt you and others.

All safety messages will follow the safety alert symbol and either the word "WARNING" or "CAUTION". These word means :

⚠ WARNING: This symbol will alert you to hazards or unsafe practices which could cause serious bodily harm or death.

⚠ CAUTION: This symbol will alert you to hazards or unsafe practices which could cause bodily injury or property damage.

Important Safety

Instructions

Please keep for future reference. Read and follow all instructions before using your oven to prevent the risk of fire, electric shock, personal injury, or damage when using the oven. This guide do not cover all possible conditions that may occur. Always contact your service agent or manufacturer about problems that you do not understand.

⚠ WARNING

- 1. Do not attempt to tamper with, or make any adjustments or repairs to the door, door seals, control panel, safety interlock switches or any other part of the oven. which involves the removal of any cover which gives protection against exposure to microwave energy. Do not operate the oven, if the door seals and adjacent parts of the microwave oven are faulty. Repairs should only be undertaken by a qualified service technician.**
- ⇒ Unlike other appliances, the microwave oven is high-voltage and high-current

- equipment. Improper use or repair could result in harmful exposure to excessive microwave energy or an electric shock.
- 2. Do not use the oven for the purpose of dehumidification. (ex. Operating the microwave oven with the wet newspapers, clothes, toys, electric devices, pet or child etc.)**
- ⇒ It can be the cause of serious damage of safety such as a fire, a burn or a sudden death due to an electric shock.

Please keep for future reference. Read and follow all instructions before using your oven to prevent the risk of fire, electric shock, personal injury, or damage when using the oven. This guide do not cover all possible conditions that may occur. Always contact your service agent or manufacturer about problems that you do not understand.

Important Safety **Instructions**

⚠ WARNING

3. The appliance and its accessible parts become hot during use. Care should be taken to avoid touching heating elements. Children less than 8 years of age shall be kept away unless continuously supervised.

4. The appliance is not intended for use by young children or infirm persons. Only allow children to use the oven without supervision when adequate instructions have been given so that the child is able to use the oven in a safe way and understands the hazards of improper use.

⤷ **Improper use may cause the damage of safety concerns such as a fire, an electric shock and a burn.**

5. Accessible parts may become hot during use. Young children should be kept away.

⤷ **They may get a burn.**

6. Liquids or other foods must not be heated in sealed containers since they are liable to explode. Remove the plastic wrapping from food before cooking or defrosting. Note though that in some cases food should be covered with plastic film, for heating or cooking.

⤷ **They could burst.**

Important Safety **Instructions**

Please keep for future reference. Read and follow all instructions before using your oven to prevent the risk of fire, electric shock, personal injury, or damage when using the oven. This guide do not cover all possible conditions that may occur. Always contact your service agent or manufacturer about problems that you do not understand.

WARNING

- 7. This appliance is not intended for use by persons (including children) with reduced physical, sensory or mental capabilities, or lack of experience and knowledge, unless they have been given supervision or instruction concerning use of the appliance by a person responsible for their safety.**
- 8. When the appliance is operated in the combination mode, children should only use the oven under adult supervision due to the temperatures generated.**

Please keep for future reference. Read and follow all instructions before using your oven to prevent the risk of fire, electric shock, personal injury, or damage when using the oven. This guide do not cover all possible conditions that may occur. Always contact your service agent or manufacturer about problems that you do not understand.

Important Safety **Instructions**

CAUTION

1. You cannot operate your oven with the door open due to the safety interlocks built into the door mechanism. It is important not to tamper with the safety interlock.

☞ It could result in harmful exposure to excessive microwave energy.
(Safety interlocks automatically switch off any cooking activity when the door is opened.)

2. Do not place any object (such as kitchen towel, napkin, etc.) between the oven front face and the door or allow food or cleaner residue to accumulate on sealing surfaces.

☞ It could result in harmful exposure to excessive microwave energy.

3. Do not operate your oven if it is damaged. It is particularly important that the oven door closes properly and that there is no damage to the: (1) door(bent), (2) hinges and latches (broken or loosened), (3) door seals and sealing surfaces.

☞ It could result in harmful exposure to excessive microwave energy.

Important Safety

Instructions

Please keep for future reference. Read and follow all instructions before using your oven to prevent the risk of fire, electric shock, personal injury, or damage when using the oven. This guide do not cover all possible conditions that may occur. Always contact your service agent or manufacturer about problems that you do not understand.

⚠ CAUTION

- 4. Please ensure cooking times are correctly set small amounts of food require shorter cooking or heating time.**
 - ☞ The over cooking may result in the food catching a fire and subsequent damage to your oven.
- 5. When heating liquids, e.g. soups, sauces and beverages in your microwave oven,**
 - * Avoid using straight sided containers with narrow necks.**
 - * Do not overheat.**
 - * Stir the liquid before placing the container in the oven and again halfway through the heating time.**

- * After heating, allow to stand in the oven for a short time, stir or shake them again carefully and check the temperature of them before consumption to avoid burns (especially, contents of feeding bottles and baby food jars).**
- ☞ Be careful when handling the container. Microwave heating of beverages can result in delayed eruptive boiling without evidence of bubbling. This could result in a sudden boil over of the hot liquid.

Please keep for future reference. Read and follow all instructions before using your oven to prevent the risk of fire, electric shock, personal injury, or damage when using the oven. This guide do not cover all possible conditions that may occur. Always contact your service agent or manufacturer about problems that you do not understand.

Important Safety **Instructions**

⚠ CAUTION

6. An exhaust outlet is located on top or bottom or side of the oven. Don't block the outlet.

➤ It could result in damage to your oven and poor cooking results.

7. Do not operate the oven when empty. It is best to leave a glass of water in the oven when not in use. The water will safely absorb all microwave energy, if the oven is accidentally started.

➤ Improper use could result in damage to your oven.

8. Do not cook food wrapped in paper towels, unless your cook book contains instructions for the food you are cooking. And do not use newspaper in place of paper towels for cooking.

➤ Improper use can be the cause of an explosion or a fire.

9. Do not use wooden containers and ceramic containers which have metallic (e.g. gold or silver) inlays. Always remove metal twist ties. Check the utensils are suitable for use in microwave ovens before use.

➤ They may heat-up and char. Especially metal objects in the oven may arc, which can cause serious damage.

Important Safety

Instructions

Please keep for future reference. Read and follow all instructions before using your oven to prevent the risk of fire, electric shock, personal injury, or damage when using the oven. This guide do not cover all possible conditions that may occur. Always contact your service agent or manufacturer about problems that you do not understand.

⚠ CAUTION

10. Do not use recycled paper products.

- ⤵ They may contain impurities which may cause sparks and/or fires when used in cooking.

11. Do not rinse the tray and rack by placing it in water just after cooking. This may cause breakage or damage.

- ⤵ Improper use could result in damage to your oven.

12. Be certain to place the oven so the front of the door is 8 cm or more behind the edge of the surface on which it is placed, to avoid accidental tipping of the appliance.

- ⤵ Improper use could result in bodily injury and oven damage.

13. Before cooking, pierce the skin of potatoes, apples or any such fruit or vegetable.

- ⤵ They could burst.

14. Do not cook eggs in their shell. Eggs in their shell and whole hardboiled eggs should not be heated in microwave ovens since they may explode, even after microwave heating has ended.

- ⤵ Pressure will build up inside the egg which will burst.

Please keep for future reference. Read and follow all instructions before using your oven to prevent the risk of fire, electric shock, personal injury, or damage when using the oven. This guide do not cover all possible conditions that may occur. Always contact your service agent or manufacturer about problems that you do not understand.

Important Safety **Instructions**

⚠ CAUTION

15. Do not attempt deep fat frying in your oven.

- This could result in a sudden boil over of the hot liquid.

16. If smoke is observed (or emitted), switch off or disconnect the oven from the power supply and keep the oven door closed in order to stifle any flames.

- It can be the cause of serious damage of safety such as a fire, an electric shock.

17. When food is heated or cooked in disposable containers of plastic, paper or other combustible materials, keep an eye on the oven and check it frequently.

- Your food may be poured due to the possibility of container deterioration, which also can cause a fire.

18. The temperature of accessible surfaces may be high when the appliance is operating. Do not touch the oven door, outer cabinet, rear cabinet, oven cavity, accessories and dishes during grill mode, convection mode and auto cook operations, before clearing make sure they are not hot.

- As they will become hot, unless wearing thick oven gloves there is the danger of a burn.

Important Safety **Instructions**

Please keep for future reference. Read and follow all instructions before using your oven to prevent the risk of fire, electric shock, personal injury, or damage when using the oven. This guide do not cover all possible conditions that may occur. Always contact your service agent or manufacturer about problems that you do not understand.

⚠ CAUTION

19. The oven should be cleaned regularly and any food deposits removed.

- ☞ Failure to maintain the oven in a clean condition could lead to deterioration of the surface that could adversely affect the life of the appliance and possibly result in a hazardous situation.

20. Only use the temperature probe recommended for this oven (for appliances having a facility to use a temperature-sensing probe).

- ☞ You can not ascertain that the temperature is accurate with unsuitable temperature probe.

21. If heating elements are provided, during use the appliance becomes hot. Care should be taken to avoid touching heating elements inside the oven.

- ☞ There is the danger of a burn.

22. Follow exact directions given by each manufacturer for their popcorn product. Do not leave the oven unattended while the corn is being popped. If corn fails to pop after the suggested times, discontinue cooking. Never use a brown paper bag for popping corn. Never attempt to pop leftover kernels.

- ☞ Overcooking could result in the corn catching a fire.

Please keep for future reference. Read and follow all instructions before using your oven to prevent the risk of fire, electric shock, personal injury, or damage when using the oven. This guide do not cover all possible conditions that may occur. Always contact your service agent or manufacturer about problems that you do not understand.

Important Safety **Instructions**

⚠ CAUTION

23. This appliance must be earthed.

The wires in this mains lead are colored in accordance with the following codes

BLUE ~ Neutral

BROWN ~ Live

GREEN & YELLOW ~ Earth

As the colours of the wires in the mains lead of this appliance may not correspond with the coloured markings identifying the terminals in your plug proceed as follows:

The wire which is colored **BLUE** must be connected to the terminal which is

marked with the letter **N** or Colored **BLACK**.

The wire which is colored **BROWN** must be connected to the terminal which is marked with the letter **L** or colored **RED**.

The wire which is colored **GREEN & YELLOW** or **GREEN** must be connected to the terminal which is marked with the letter **E** or \perp .

If the supply cord is damaged, it must be replaced by the manufacturer or its service agent or a similarly qualified person in order to avoid a hazard.

- ⓘ Improper use may cause serious electric damage.

Important Safety

Instructions

Please keep for future reference. Read and follow all instructions before using your oven to prevent the risk of fire, electric shock, personal injury, or damage when using the oven. This guide do not cover all possible conditions that may occur. Always contact your service agent or manufacturer about problems that you do not understand.

⚠ CAUTION

24. Do not use harsh abrasive cleaners or sharp metal scrapers to clean the oven door glass.

⇒ They can scratch the surface, which may result in shattering of the glass.

25. This oven should not be used for commercial catering purposes.

⇒ Improper use could result in damage to your oven.

26. The microwave oven must be operated with the door of built-in cabinet open.

⇒ If the door of cabinet is closed while operating, the airflow get worse and it could result in a fire or damage to your oven and the cabinet.

27. The connection may be achieved by having the plug accessible or by incorporation a switch in the fixed wiring in accordance with the wiring rules.

⇒ Using improper plug or switch can cause an electric shock or a fire.

28. This appliance is not intended for use by persons (including children) with reduced physical, sensory or mental capabilities, or lack of experience and knowledge, unless they have been given supervision or instruction concerning use of the appliance by a person responsible for their safety.

Please keep for future reference. Read and follow all instructions before using your oven to prevent the risk of fire, electric shock, personal injury, or damage when using the oven. This guide do not cover all possible conditions that may occur. Always contact your service agent or manufacturer about problems that you do not understand.

Important Safety **Instructions**

⚠ CAUTION

- 29. (Young)Children should be supervised to ensure that they do not play with the appliance.**
- 30. This appliance can be used by children aged from 8 years and above and persons with reduced physical, sensory or mental capabilities or lack of experience and knowledge if they have been given supervision or instruction concerning use of the appliance in a safe way and understand the hazards involved. Children shall not play with the appliance. Cleaning and user**

- maintenance shall not be undertaken by children without supervision.**
- 31. The appliance is not intended to be operated by means of an external timer or separate remote-control system.**
- 32. The contents of feeding bottles and baby food jars shall be stirred or shaken and the temperature checked before consumption, in order to avoid burns.**
- 33. Steam cleaner is not to be used.**

Precautions

Precautions to avoid possible exposure to excessive microwave energy.

You cannot operate your oven with the door open due to the safety interlocks built into the door mechanism. These safety interlocks automatically switch off any cooking activity when the door is opened; which in the operation of microwave function could result in harmful exposure to microwave energy.

It is important not to tamper with the safety interlocks.

Do not place any object between the oven front face and the door or allow food or cleaner residue to accumulate on sealing surfaces.

Do not operate your oven if it is damaged. It is particularly important that the oven door closes properly and that there is no damage to the: (1) door(bent), (2) hinges and latches (broken or loosened), (3) door seals and sealing surfaces.

Your oven should not be adjusted or repaired by anyone except qualified service personnel.

WARNING

Please ensure cooking times are correctly set as over cooking may result in the FOOD catching fire and subsequent damage to your oven.

When heating liquids, e.g. soups, sauces and beverages in your oven with microwave function, delayed eruptive boiling can occur without evidence of bubbling. This could result in a sudden boil over of the hot liquid. To prevent this possibility the following steps should be taken:

- 1 Avoid using straight sided containers with narrow necks.
- 2 Do not overheat.
- 3 Stir the liquid before placing the container in the oven and again halfway through the heating time.
- 4 After heating, allow to stand in the oven for a short time, stir or shake them(especially the contents of feeding bottles and baby food jars) again carefully and check the temperature of them before consumption to avoid burns (especially, contents of feeding bottles and baby food jars). Be careful when handling the container.

WARNING

Always allow food to stand after being cooked by microwaves and check the temperature of them before consumption. Especially contents of feeding bottles and baby food jars.

Unpacking & Installing

By following the basic steps on these two pages you will be able to quickly check that your oven is operating correctly. Please pay particular attention to the guidance on where to install your oven. When unpacking your oven make sure you remove all accessories and packing. Check to make sure that your oven has not been damaged during delivery.

1 Unpack your oven and place it on a flat level surface.

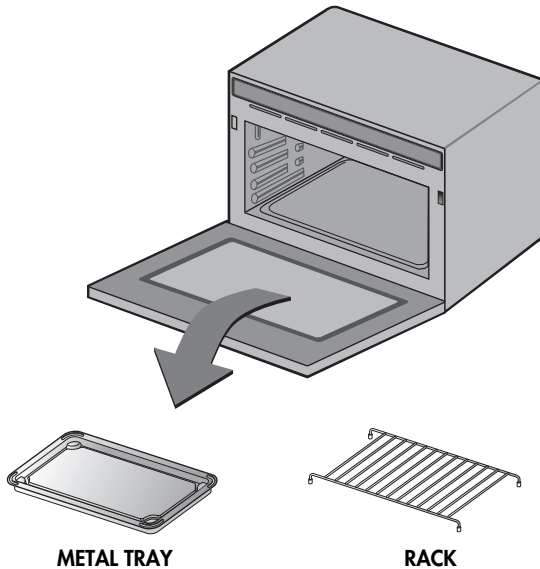

2 Place the oven in the level location of your choice with more than 85cm height but make sure there is at least 20cm of space on the top and 10cm at the rear for proper ventilation. The front of the oven should be at least min. 8cm/max. 22cm from the edge of the surface to prevent tipping. An exhaust outlet is located on bottom or side of the oven. Blocking the outlet can damage the oven.

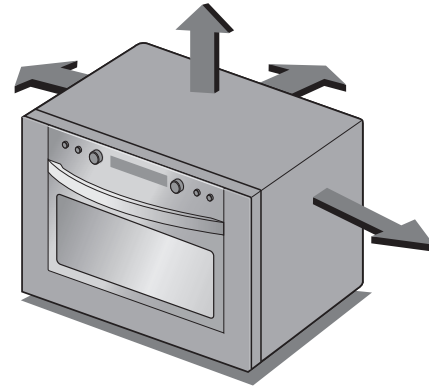

- * THIS OVEN SHOULD NOT BE USED FOR COMMERCIAL CATERING PURPOSES.
- * THIS OVEN CAN BE USED AS BUILT-IN TYPE .
- * MUST USE THE BUILT-IN KIT THAT IS MADE BY LG ELECTRONICS.

3 Plug your oven into a standard household socket. Make sure your oven is the only appliance connected to the socket. **If your oven does not operate properly, unplug it from the electrical socket and then plug it back in.**

4 Open your oven door by pulling the **DOOR HANDLE**. Place the **RACK** inside the oven.

5 Fill a **microwave safe container** with 300 ml (1/2 pint) of water. Place on the rack on the oven bottom surface and close the oven door. If you have any doubts about what type of container to use please refer to page 42.

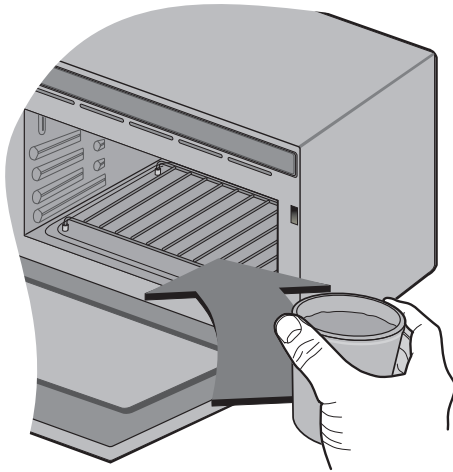

6 Press the **STOP/CLEAR** button, and press the **ENTER/START/Q-START** button one time to set 30 seconds of cooking time.



7 The **DISPLAY** will count down from 30 seconds. When it reaches 0 it will sound BEEPS. Open the oven door and test the temperature of the water. If your oven is operating the water should be warm. **Be careful when removing the container it may be hot.**



YOUR OVEN IS NOW INSTALLED

8 The contents of feeding bottles and baby food jars shall be stirred or shaken and the temperature checked before consumption, in order to avoid burns.

Control Panel

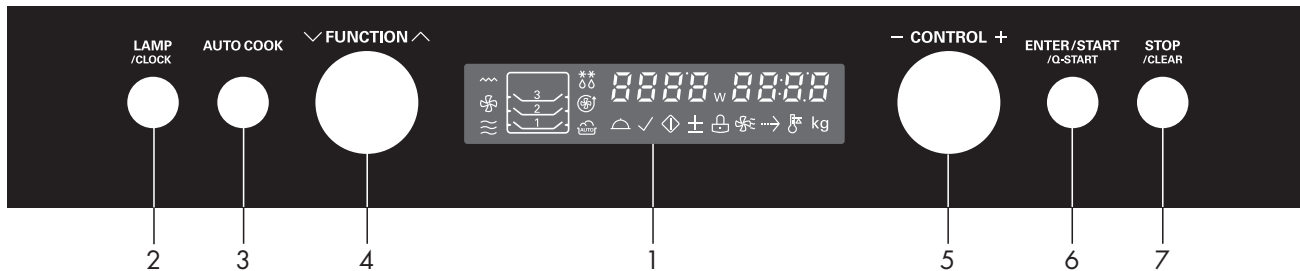

1. DISPLAY WINDOW: You can show time of day, cooking time, power level and cooking categories.

2. LAMP/CLOCK:

- **LAMP:** You can see the foods while cooking by pressing this button.
- **CLOCK:** You can set the time of day.

3. AUTO COOK : Auto cook allows you to cook most of your favorite food quickly by selecting the food type and the weight of the food.

4. FUNCTION SELECT: You can select cooking categories.

5. CONTROL:

- You can set cooking times, temperature, weight and cooking categories.
- While cooking with auto and manual function, you can lengthen or shorten the cooking time at any point by turning the dial (except defrost mode).

6. ENTER/START/Q-START:

- In order to start cooking which is selected, press button one time.
- The quick start feature allows you to set 30 seconds intervals of HIGH power cooking with a touch of the quick start button.

7. STOP/CLEAR: You can stop over and clear all entries except time of day.

Setting the Clock

You can set either 12 hour clock or 24 hour clock.
In the following example I will show you how to set the time for 10:30 when using the 24 clock.
Make sure that you have removed all packaging from your oven.



When your oven is plugged in for the first time or when power resumes after a power cut, a '0' will be shown in the display; you will have to reset the clock.

If the clock (or display) shows any strange looking symbols, unplug your oven from the electrical socket and plug it back in and reset the clock.

1 Make sure that you have correctly installed your oven as described earlier in this book.

Press **STOP/CLEAR**.

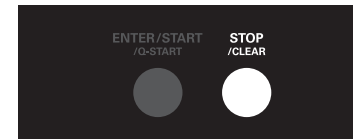

2 Press **LAMP/CLOCK** once.

(If you want to use a 12 hour clock, Press **LAMP/CLOCK** once more.
If you want to change different option after setting clock, you have to unplug and plug it back in.)

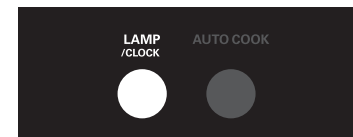

3 Turn **CONTROL dial** until display shows "10:00".

Press **ENTER/START/Q-START** for hour confirmation

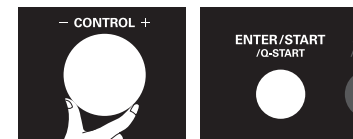

4 Turn **CONTROL dial** until display shows "10:30".

Press **ENTER/START/Q-START**.
The clock starts counting.

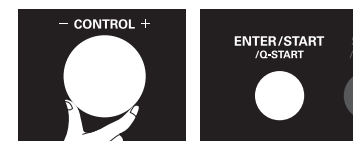



Child Lock

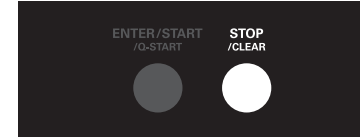

Your oven has a safety feature that prevents accidental running of the oven. Once the child lock is set, you will be unable to use any functions and no cooking can take place. However your child can still open the oven door.

Press **STOP/CLEAR**.





Press and hold **STOP/CLEAR** until "L" and  appears on the display and BEEP sounds. The **CHILD LOCK** is now set.

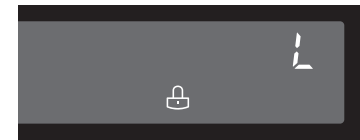

The time will disappear on the display but will reappear on the display a few seconds later.

If any button is pressed, "L" and  will appear on the display



To cancel **CHILD LOCK** press and hold **STOP/CLEAR** until "L" and  disappears. You will hear BEEP when it's released.

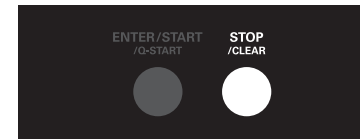
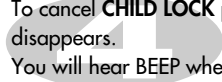

Convection Preheat

In the following example I will show you how to preheat the oven at a temperature of 200°C.



The convection oven has a temperature range of 40 °C and 100 °C~230 °C (180 °C is automatically available when convection mode is selected).

The oven has a ferment function at the oven temperature of 40 °C. You may wait until the oven is cool because you cannot use a ferment function if the oven temperature is over 40 °C.

Your oven will take a few minutes to reach the selected temperature.

Once it has reached correct temperature, your oven will BEEP to let you know that it has reached the correct temperature.

Then place your food in your oven: then tell your oven to start cooking.

Press **STOP/CLEAR**.

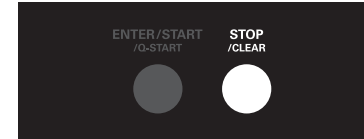

Turn **FUNCTION selection dial** to select **Conv.**

The following indication is displayed: "🌀"

Press **ENTER/START/Q-START** for mode confirmation.



Turn **CONTROL dial** until display shows "200°C".

Press **ENTER/START/Q-START** for temperature confirmation.

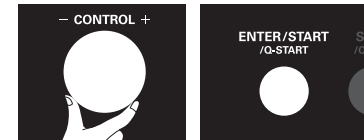

Press **ENTER/START/Q-START**.

Preheating will be started with displaying "Pr-H".

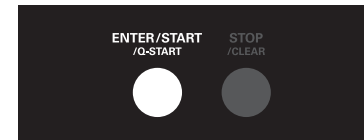

Convection Cooking

In the following example I will show you how to preheat the oven first, then cook some food at a temperature of 230°C for 50 minutes.



If you do not set a temperature your oven will automatically select 180 °C, the cooking temperature can be changed by turning **CONTROL dial**.

The metal tray must be used during convection cooking.

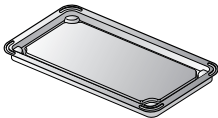

* Tray Location

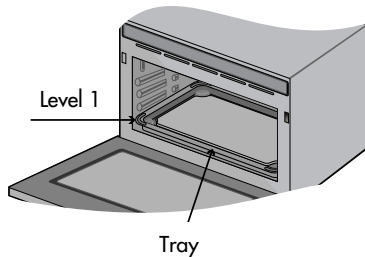

Press **STOP/CLEAR**.



Turn **FUNCTION selection dial** to select **Conv.**
The following indication is displayed: "🌀"

Press **ENTER/START/Q-START** for mode confirmation.



Turn **CONTROL dial** until display shows "230°C".

Press **ENTER/START/Q-START** for temperature confirmation.

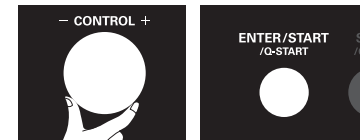

Turn **CONTROL dial** until display shows "50:00".



Press **ENTER/START/Q-START**.

When cooking you can increase or decrease cooking time by turning **CONTROL dial**.



Grill Cooking

In the following example I will show you how to use the Grill to cook some food for 12 minutes.



This feature will allow you to brown and crisp food quickly.

The rack in metal tray must be used during grill cooking.

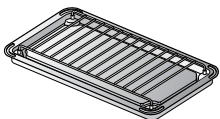

* Tray Location

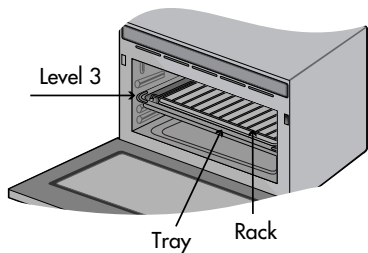

Press **STOP/CLEAR**.

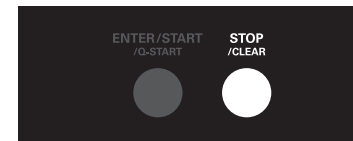

Turn **FUNCTION** selection dial to select **Grill**.
The following indication is displayed: " ~ ~ "

Press **ENTER/START/Q-START** for mode confirmation.



Turn **CONTROL** dial until display shows "12:00".



Press **ENTER/START/Q-START**.

After cooking you must wear gloves and container to take metal tray out oven, because metal tray is very hot.

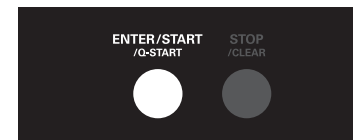

Grill combi Cooking

In the following example I will show you how to programme your oven with micro power 300W and grill for a cooking time of 25 minutes.

Your oven has a combination cooking feature which allows you to cook food with **heater** and **microwave**. This generally means it takes less time to cook your food.

You can set four kinds of micro power level (90W, 180W, 300W and 450W) in grill combi mode.

The rack in metal tray must be used during grill combi. cooking.

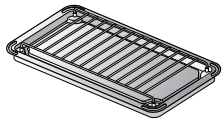

* Tray Location

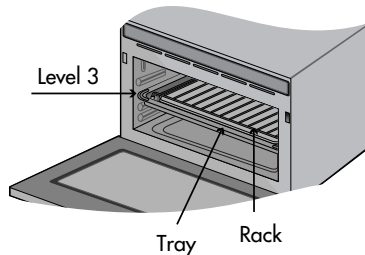

Press **STOP/CLEAR**.



Turn **FUNCTION** selection dial to select **Grill Combi**. The following indications are displayed: "≈", "≈≈".



Press **ENTER/START/Q-START** for mode confirmation.



Turn **CONTROL** dial until display shows "300W".



Press **ENTER/START/Q-START** for power confirmation.

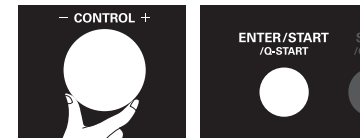

Turn **CONTROL** dial until display shows "25:00".



Press **ENTER/START/Q-START**.



After cooking you must wear gloves and container to take metal tray out oven, because metal tray is very hot.

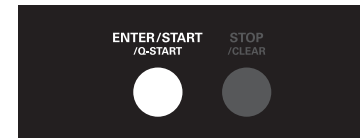

Convection combi Cooking

In the following example I will show you how to programme your oven with micro power 300W and at a temperature 200°C for a cooking time of 25 minutes.



You can set four kinds of micro power level (90W, 180W, 300W and 450W) in convection combi mode.

The rack in metal tray must be used during Convection combi. cooking.

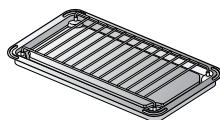

* Tray Location

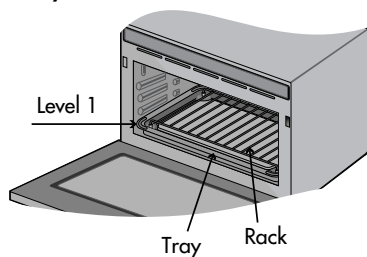

Press **STOP/CLEAR**.

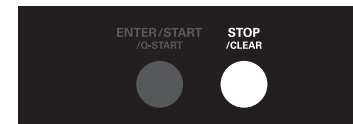

Turn **FUNCTION** selection dial to select **Conv. Combi**.
The following indications are displayed: "≈", "☼".

Press **ENTER/START/Q-START** for mode confirmation.



Turn **CONTROL** dial until display shows "200°C".

Press **ENTER/START/Q-START** for temperature confirmation.

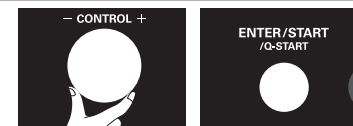

Turn **CONTROL** dial until display shows "300W".

Press **ENTER/START/Q-START** for power confirmation.

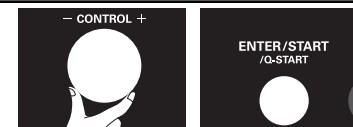

Turn **CONTROL** dial until display shows "25:00".

Press **ENTER/START/Q-START**.

After cooking you must wear gloves and container to take metal tray out oven, because metal tray is very hot.

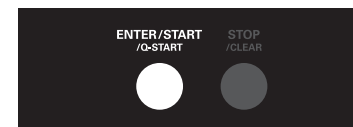

Auto Cook

In the following example I will show you how to cook 0.4kg of Sausages.



Auto Cook menus are programmed. Auto Cook allows you to cook most of your favorite food by selecting the food type and the weight of the food.

Press **STOP/CLEAR**.

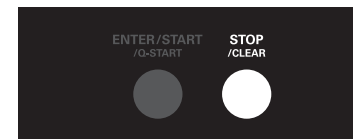

Press **AUTO COOK** once "  ".

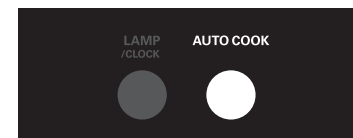

Turn **CONTROL dial** until display shows "SC 2".

Press **ENTER/START/Q-START** for category confirmation.

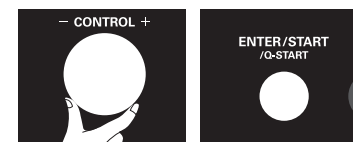

Turn **CONTROL dial** until display shows "0.4kg".

Press **ENTER/START/Q-START**.

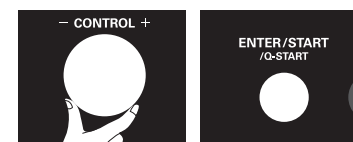

After cooking you must wear gloves and container to take metal tray out oven, because metal tray is very hot.

<i>Function</i>	<i>Category</i>		<i>Weight Limit</i>	<i>Utensil</i>	<i>Level</i>	<i>Food Temp.</i>	<i>Instructions</i>
Auto Cook	SC 1	Steak	0.3–0.6 kg	Rack on the Metal tray	3	Refrigerated	Choose steak of 200g weight and 2.5cm thickness each. Season with salt and pepper or as desired. Place food on the rack on the metal tray. Choose the menu and weight, press start. When BEEP, turn food over. And then press start to continue cooking. After cooking, serve immediately.
	SC 2	Sausages	0.2–0.6 kg	Rack on the Metal tray	3	Refrigerated	Remove all packages and slit on the surface. Place sausages on the rack on the metal tray. Choose the menu and weight, press start. When BEEP, turn food over. And then press start to continue cooking. After cooking, serve immediately.

<i>Function</i>	<i>Category</i>		<i>Weight Limit</i>	<i>Utensil</i>	<i>Level</i>	<i>Food Temp.</i>	<i>Instructions</i>
Auto Cook	SC 3	Lasagna	1	26X17cm baking dish on the Rack on the Metal tray	2	Refrigerated	<p>Ingredients 9 lasagna sheets 500g spaghetti sauce 600g cheese sauce 300g grated mozzarella cheese 30g grated parmesan cheese</p> <p>* Cheese sauce 60g butter 50g all-purpose flour Pinch ground nutmeg 500ml milk 20g grated parmesan cheese</p> <p>Melt butter in a small saucepan. Add flour and nutmeg, stirring until smooth. Gradually add milk and stir until sauce boils and thickens. Reduce heat and add parmesan cheese. Stir until cheese melts well.</p> <ol style="list-style-type: none"> 1. Cook lasagna sheets according to package directions and drain. 2. Spread about 125g spaghetti sauce in the 26 X 17cm baking dish. 3. Layer the 3 lasagna sheets, 300g cheese sauce, 125g spaghetti sauce and 100g mozzarella cheese. Repeat layering. 4. Finally layer the remained lasagna sheets, spread 125g spaghetti sauce, sprinkle with 100g mozzarella cheese and 30g parmesan cheese. 5. Place food on the rack on the metal tray. Choose the menu, press start. After cooking, remove from the oven and stand for 10 minutes.

<i>Function</i>	<i>Category</i>		<i>Weight Limit</i>	<i>Utensil</i>	<i>Level</i>	<i>Food Temp.</i>	<i>Instructions</i>											
Auto Cook	SC 4	Potato Bake	1	25X25cm baking dish on the Rack on the Metal tray	1	Room	<table border="1"> <tr> <td colspan="2">Ingredients</td> </tr> <tr> <td>4 potatoes</td> <td>2 teaspoons all-purpose flour</td> </tr> <tr> <td>125g cheddar cheese</td> <td>Pepper</td> </tr> <tr> <td>1 shallots or onion</td> <td>250ml cream</td> </tr> <tr> <td colspan="2">6 slices ham or bacon</td> </tr> </table> <ol style="list-style-type: none"> 1. Peel and slice potatoes and onion thinly. 2. Slice ham or bacon and grate the cheese. 3. Put a layer of potato slices in the 25X25cm baking dish. 4. Sprinkle ham or bacon, onions, cheese, flour and pepper. 5. Repeat the layering with above method. 6. The final layer should be potatoes, covered with only cheese and pepper. 7. Pour cream over. 8. Place the baking dish on the rack on the metal tray. 9. Choose the menu, press start. After cooking, remove from the oven and stand for 10 minutes. 	Ingredients		4 potatoes	2 teaspoons all-purpose flour	125g cheddar cheese	Pepper	1 shallots or onion	250ml cream	6 slices ham or bacon		
	Ingredients																	
4 potatoes	2 teaspoons all-purpose flour																	
125g cheddar cheese	Pepper																	
1 shallots or onion	250ml cream																	
6 slices ham or bacon																		
SC 5	Baked Fish	1	26X17cm baking dish on the Rack on the Metal tray	1	Refrigerated	<table border="1"> <tr> <td colspan="2">Ingredients</td> </tr> <tr> <td>2-3 sliced tomatoes</td> <td>1 chopped pickled gherkin</td> </tr> <tr> <td>350-400g hake or any other firm fish</td> <td>1 chopped onion</td> </tr> <tr> <td>50g bacon</td> <td>1 teaspoon chopped capers</td> </tr> <tr> <td>1 apple (granny smith) / sliced</td> <td>1 teaspoon chopped parsley</td> </tr> <tr> <td></td> <td>100g cheddar cheese</td> </tr> </table> <ol style="list-style-type: none"> 1. Line the baking dish with the sliced tomatoes. 2. Place the fish on top of the tomatoes. 3. Mix the bacon, apple, gherkin and onion with the capers and spoon over the fish. 4. Mix the parsley and cheese together and sprinkle on top of the fish. 5. Place the baking dish on the rack on the metal tray. 6. Choose the menu, press start. After cooking, remove from the oven and stand for 10 minutes. 	Ingredients		2-3 sliced tomatoes	1 chopped pickled gherkin	350-400g hake or any other firm fish	1 chopped onion	50g bacon	1 teaspoon chopped capers	1 apple (granny smith) / sliced	1 teaspoon chopped parsley		100g cheddar cheese
Ingredients																		
2-3 sliced tomatoes	1 chopped pickled gherkin																	
350-400g hake or any other firm fish	1 chopped onion																	
50g bacon	1 teaspoon chopped capers																	
1 apple (granny smith) / sliced	1 teaspoon chopped parsley																	
	100g cheddar cheese																	

<i>Function</i>	<i>Category</i>		<i>Weight Limit</i>	<i>Utensil</i>	<i>Level</i>	<i>Food Temp.</i>	<i>Instructions</i>
Auto Cook	SC 6	Oven Chips	0.2–0.5 kg	Metal tray	1	Frozen	Spread frozen potato products out on the metal tray. For the best results, cook in a single layer. Choose the menu and weight, press start. After cooking, serve immediately.
	SC 7	Quiche	1	25cm tart pan on the Rack on the Metal tray	1	Refrigerated	<div style="border: 1px solid black; padding: 5px;"> <p>Ingredients</p> <ul style="list-style-type: none"> 1 baked pie shell 1 medium onion(150g), chopped finely and cooked 3 bacon rashers, chopped and cooked 3 eggs 300ml cream 150g grated cheddar cheese </div> <ol style="list-style-type: none"> 1. Place baked pie shell into the 25cm tart pan. 2. Put the cooked onion, bacon and cheddar cheese on the pie shell. 3. Mix eggs and cream and then stir well. 4. Pour the egg mixture into the pie shell. 5. Place tart pan on the rack on the metal tray. 6. Choose the menu, press start. After cooking, remove from the oven and stand for 10 minutes.

<i>Function</i>	<i>Category</i>		<i>Weight Limit</i>	<i>Utensil</i>	<i>Level</i>	<i>Food Temp.</i>	<i>Instructions</i>
Auto Cook	SC 8	Bobotie	1	1.5 ℓ casserole on the Rack on the Metal tray	1	Room	<p>Ingredients</p> <p>200ml milk 2 slices of bread 750g minced beef 1 chopped onion (medium size) 2 tablespoons grated fresh ginger 3 garlic cloves grated 1 tablespoon apricot jam 30ml lemon juice 1/4 cup of blanched almonds 2 teaspoons medium (or hot) curry powder 1 teaspoon turmeric 2 teaspoons salt 4 bay or lemon leaves 3 eggs</p> <ol style="list-style-type: none"> 1. Soak the bread in 100ml milk. 2. Mix it with the minced beef. 3. Mix all the other ingredients except the remaining milk, oil, eggs and bay leaves. 4. Heat oil in a pan and cook the mixture until turn lightly brown. 5. Put them into a 1.5 ℓ casserole and reserve. 6. Beat eggs with remaining milk and pour over meat. 7. Place casserole on the rack on the metal tray. 8. Choose the menu, press start. After cooking, remove from the oven. 9. Serve with plain or yellow rice.

<i>Function</i>	<i>Category</i>		<i>Weight Limit</i>	<i>Utensil</i>	<i>Level</i>	<i>Food Temp.</i>	<i>Instructions</i>
Auto Cook	SC 9	Chicken Pieces	0.2–0.8 kg	Rack on the Metal tray	3	Refrigerated	Brush chicken pieces with oil or seasonings, if desired. Place food on the rack on the metal tray. Choose the menu and weight, press start. When BEEP, turn food over. And then press start to continue cooking. After cooking, remove from the oven and stand for 10 minutes.
	SC 10	Leg of Lamb	0.5–1.5 kg	Rack on the Metal tray	1	Refrigerated	Season with salt, pepper and oil or as desired. Place food on the rack on the metal tray. Choose the menu and weight, press start. When BEEP, turn food over. And then press start to continue cooking. After cooking, stand covered with foil for 10 minutes.
	SC 11	Roast Chicken	0.8–1.5 kg	Rack on the Metal tray	1	Refrigerated	Brush the chicken with oil. Sprinkle with salt and black pepper on the chicken. Place food on the rack on the metal tray. Choose the menu and weight, press start. When BEEP, turn food over. And then press start to continue cooking. After cooking, stand covered with foil for 10 minutes.

Function	Category		Weight Limit	Utensil	Level	Food Temp.	Instructions
Auto Cook	SC 12	Apple Tart	1	25cm tart pan on the Rack on the Metal tray	2	Room	<p>Ingredients</p> <ul style="list-style-type: none"> 1 apple / sliced 125g butter 1 egg ³/₄ cup sugar 375g all-purpose flour 1 ¹/₂ teaspoon baking powder ¹/₂ teaspoon salt <p>1. Beat the sugar and butter until light and creamy. 2. Add egg and beat again. 3. Mix the egg mixture with flour, baking powder and salt. 4. Roll out the dough on greased tart pan. 5. Place sliced apples on the top of the dough. 6. Place the tart pan on the rack on the metal tray. 7. Choose the menu, press start. After cooking, remove from the oven. 8. Serve with thick cream.</p>

< Metal Tray >

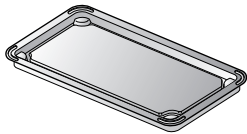

< Rack >

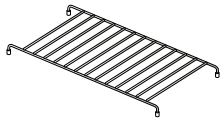

< Rack + Metal Tray >

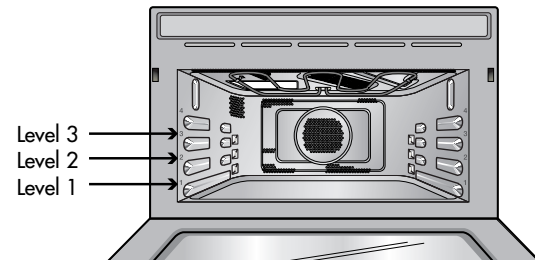
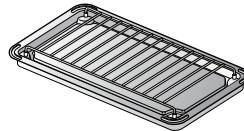

Defrost

The temperature and density of food varies, I would recommend that the food be checked before cooking commences. Pay particular attention to large joints of meat and chicken, some foods should not be completely thawed before cooking. For example fish cooks so quickly that it is sometimes better to begin cooking while still slightly frozen. The bread programme is suitable for defrosting small items such as rolls or a small loaf. These will require a standing time to allow the centre to thaw. In the following example I will show you how to defrost 0.8Kg of frozen poultry.

*** When defrosting, use only rack.**



Your oven has four microwave defrost settings:- **Meat, Poultry, Fish and Bread**; each defrost category has different power settings. Repeated presses of the **Defrost** button will select a different setting.

* Rack Location

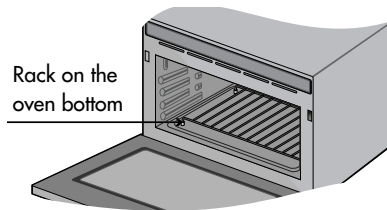

Press **STOP/CLEAR**.

Weigh the food that you are about to defrost. Be certain to remove any metallic ties or wraps; then place the food on microwave safe dish on the rack on the oven bottom and close the oven door.



Turn **FUNCTION** selection dial to select **Defrost**.

The following indication is displayed: "0.0"

Press **ENTER/START/Q-START** for mode confirmation.

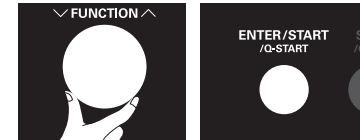

Turn **CONTROL** dial until display shows "dEF2".

Press **ENTER/START/Q-START** for category confirmation.

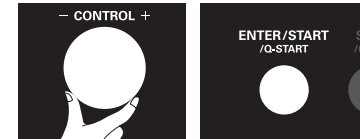

Enter the weight of the frozen food that you are about to defrost.

Turn **CONTROL** dial until display shows "0.8kg" for the weight of frozen food.

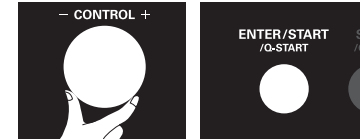

Press **ENTER/START/Q-START**.

During defrosting your oven will "BEEP", at which point open the oven door, turn food over and separate to ensure even thawing. Remove any portions that have thawed or shield them to help slow down thawing. After checking, close the oven door and press **ENTER/START/Q-START** to resume defrosting.

Your oven will not stop defrosting (even when the beep sounded) unless the door is opened.

Defrosting Guide

- * Food to be defrosted should be in a suitable microwave proof container and place uncovered on the rack.
 - * If necessary, shield small areas of meat or poultry with flat pieces of aluminum foil. This will prevent thin areas becoming warm during defrosting. Ensure the foil does not touch the oven walls.
 - * Separate items like minced meat, chops, sausages and bacon as soon as possible.
- When BEEP, turn food over.** Remove defrosted portions. Continue to defrost remaining pieces.
After defrosting, allow to stand until completely thawed.

Category	Weight Limit	Utensil	Level	Food
Meat (dEF1)	0.1 – 2.0 kg	Microwave-safe dish on the rack	Bottom	Meat Minced beef, Fillet steak, Cubes for stew, Sirloin steak, Pot roast, Rump roast, Beef burger Pork chops, Lamb chops, Rolled roast, Sausage, Cutlets(2cm) Turn food over at beep. After defrosting, let stand for 5-15 minutes.
Poultry (dEF2)	0.1 – 2.0 kg			Poultry Whole chicken, Legs, Breasts, Turkey breasts. Turn food over at beep. After defrosting, let stand for 20-30 minutes.
Fish (dEF3)	0.1 – 2.0 kg			Fish Fillets, Steaks, Whole fish, Sea foods Turn food over at beep. After defrosting, let stand for 10-20 minutes.
Bread (dEF4)	0.1 – 0.5 kg			Bread Sliced bread, Buns, Baguette, etc. After defrosting, let stand for 5 minutes.

EZ Clean

In the following example I will show you how to remove smell in the oven.



The oven has a special function to remove the smell in the oven.

You can use the EZ Clean function without food in the oven.

Press **STOP/CLEAR**.

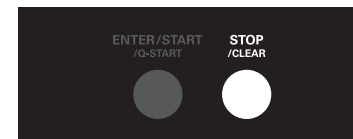

Turn **FUNCTION** selection dial to select **EZ Clean**.
The following indication is displayed: "⌂"



Press **ENTER/START/Q-START**.

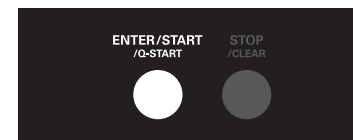

Micro Power Cooking

In the following example I will show you how to cook some food on 450W power for 5 minutes.



Your oven has five microwave Power settings. High power is automatically selected and turning of dial will select a different power level.

POWER	
HIGH	700 W
MEDIUM HIGH	450 W
MEDIUM	300 W
DEFROST MEDIUM LOW	180 W
LOW	90 W

Make sure that you have correctly installed your oven as described earlier in this book.

Press **STOP/CLEAR**.

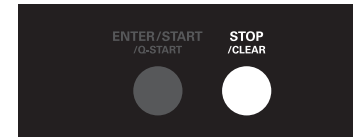

Turn **FUNCTION selection dial** to select **Microwave**.
The following indication is displayed: "≐"

Press **ENTER/START/Q-START** for mode confirmation.



Turn **CONTROL dial** until display shows "450W".

Press **ENTER/START/Q-START** for power confirmation.

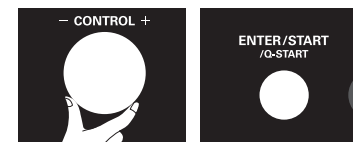

Turn **CONTROL dial** until display shows "5:00".

Press **ENTER/START/Q-START**.

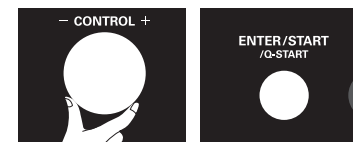

Micro Power Level

This oven is equipped with 5 power levels to give you maximum flexibility and control over cooking. The table below shows the examples of food and their recommended cooking power levels for use with this oven.

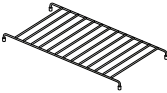
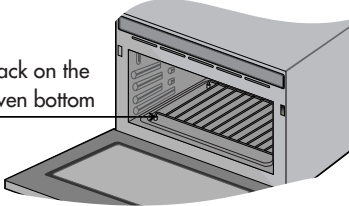
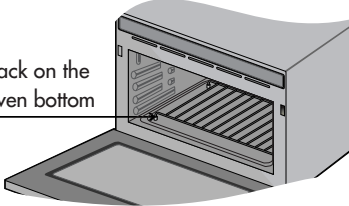
POWER LEVEL	OUTPUT	USE	ACCESSORY
HIGH	700W	<ul style="list-style-type: none"> * Boil Water * Brown minced beef * Cook poultry pieces, fish, vegetables * Cook tender cuts of meat 	Rack 
MEDIUM HIGH	450W	<ul style="list-style-type: none"> * All reheating * Roast meat and poultry * Cook mushrooms and shellfish * Cook foods containing cheese and eggs 	* Rack Location 
MEDIUM	300W	<ul style="list-style-type: none"> * Bake cakes and scones * Prepare eggs * Cook custard * Prepare rice, soup 	Rack on the oven bottom 
DEFROST/ MEDIUM LOW	180W	<ul style="list-style-type: none"> * All thawing * Melt butter and chocolate * Cook less tender cuts of meat 	
LOW	90W	<ul style="list-style-type: none"> * Soften butter & cheese * Soften ice cream * Raise yeast dough 	



Note:

The feeding bottles should not be on rack during operating. This situation can make a damage of feeding bottles' bottom. The feeding bottles should be operated on metal tray located at level 1 inside cavity.

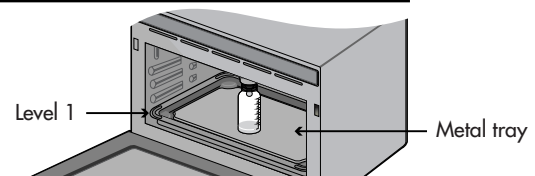

Quick Start

In the following example I will show you how to set 2 minutes of cooking on high power (700W).



The **Quick Start** feature allows you to set 30 seconds intervals of HIGH power (700W) cooking with pressing of the **ENTER/START/Q-START** button.

Press **STOP/CLEAR**.

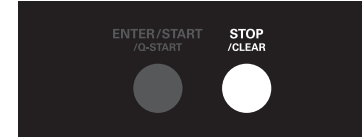

Press **ENTER/START/Q-START** four times to select 2 minutes on HIGH power (700W).
Your oven will start before you have finished the fourth press.

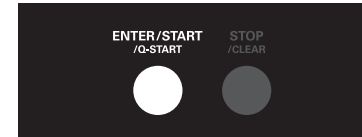

More or Less Cooking

In the following example I will show you how to change the preset AUTO COOK programmes for a longer or shorter cooking time.



If you find that your food is over or undercooked when using the Auto Cook programme, you can increase or decrease cooking time by turning the **CONTROL dial**.

You can lengthen or shorten the cooking time(except defrost mode) at any point by turning the **CONTROL dial**.

Press **STOP/CLEAR**.

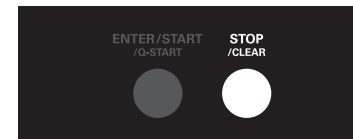

Set the required **AUTO COOK** programme.

*See **AUTO COOK** (page. 27).
Select weight of food.

Press **ENTER/START/Q-START**.



Turn **CONTROL dial**.

The cooking time will increase or decrease.



Microwave-safe Utensils

Never use metal or metal trimmed utensils in using microwave function

Microwaves cannot penetrate metal. They will bounce off any metal object in the oven and cause arcing, an alarming phenomenon that resembles lightning. Most heat resistant non metallic cooking utensils are safe for use in your oven. However, some may contain materials that render them unsuitable as microwave cookware. If you have any doubts about a particular utensil, there's a simple way to find out if it can be used in using microwave function. Place the utensil in question next to a glass bowl filled with water in using microwave function. Microwave at power HIGH for 1 minute. If the water heats up but the utensil remains cool to the touch, the utensil is microwave-safe. However, if the water does not change temperature but the utensil becomes warm, microwaves are being absorbed by the utensil and it is not safe for use in using microwave function. You probably have many items on hand in your kitchen right now that can be used as cooking equipment in using microwave function. Just read through the following checklist.

Dinner plates

Many kinds of dinner-ware are microwave-safe. If in doubt consult the manufacturer's literature or perform the microwave test.

Glassware

Glassware that is heat-resistant is microwave-safe. This would include all brands of oven tempered glass cookware. However, do not use delicate glassware, such as tumblers or wine glasses, as these might shatter as the food warms.

Plastic storage containers

These can be used to hold foods that are to be quickly reheated. However, they should not be used to hold foods that will need considerable time in the oven as hot foods will eventually warp or melt plastic containers.

Paper

Paper plates and containers are convenient and safe to use in using microwave function, provided that the cooking time is short and foods to be cooked are low in fat and moisture. Paper towels are also very useful for wrapping foods and for lining baking trays in which greasy foods such as bacon are cooked. In general, avoid coloured paper products as the colour may run. Some recycled paper products may contain impurities which could cause arcing or fires when used in using microwave function.

Plastic cooking bags

Provided they are made specially for cooking, cooking bags are microwave safe. However, be sure to make a slit in the bag so that steam can escape. Never use ordinary plastic bags for cooking in using microwave function, as they will melt and rupture.

Plastic microwave cookware

A variety of shapes and sizes of microwave cookware are available. For the most part, you can probably use items you already have on hand rather than investing in new kitchen equipment.

Pottery, stoneware and ceramic

Containers made of these materials are usually fine for use in using microwave function, but they should be tested to be sure.

CAUTION

Some items with high lead or iron content are not suitable for cooking utensils.

Utensils should be checked to ensure that they are suitable for use in using microwave function.

Food characteristics & Microwave cooking

Keeping an eye on things

The recipes in the book have been formulated with great care, but your success in preparing them depends on how much attention you pay to the food as it cooks. Always watch your food while it cooks. Your microwave function is equipped with a light that turns on automatically when the oven is in operation so that you can see inside and check the progress of your food. Directions given in recipes to elevate, stir, and the like should be thought of as the minimum steps recommended. If the food seems to be cooking unevenly, simply make the necessary adjustments you think appropriate to correct the problem.

Factors affecting microwave cooking times

Many factors affect cooking times. The temperature of ingredients used in a recipe makes a big difference in cooking times. For example, a cake made with ice-cold butter, milk, and eggs will take considerably longer to bake than one made with ingredients that are at room temperature. All of the recipes in this book give a range of cooking times. In general, you will find that the food remains undercooked at the lower end of the time range, and you may sometimes want to cook your food beyond the maximum time given, according to personal preference. The governing philosophy of this book is that it is best for a recipe to be conservative in giving cooking times. While overcooked food is ruined for good. Some of the recipes, particularly those for bread, cake, and custards, recommend that food be removed from the oven when they are slightly undercooked. This is not a mistake. When allowed to stand, usually covered, these foods will continue to cook outside of the oven as the heat trapped within the outer portions of the food gradually travels inward. If the food is left in the oven until it is cooked all the way through, the outer portions will become overcooked or even burnt. You will become increasingly skilful in estimating both cooking and standing times for various foods.

Density of food

Light, porous food such as cakes and breads cook more quickly than heavy, dense foods such as roasts and casseroles. You must take care when microwaving porous food that the outer edges do not become dry and brittle.

Height of food

The upper portion of tall food, particularly roasts, will cook more quickly than the lower portion. Therefore, it is wise to turn tall food during cooking, sometimes several times.

Moisture content of food

Since the heat generated from microwaves tends to evaporate moisture, relatively dry food such as roasts and some vegetables should either be sprinkled with water prior to cooking or covered to retain moisture.

Bone and fat content of food

Bones conduct heat and fat cooks more quickly than meat. Care must be taken when cooking bony or fatty cuts of meat that they do not cook unevenly and do not become overcooked.

Quantity of food

The number of microwaves in your oven remains constant regardless of how much food is being cooked. Therefore, the more food you place in the oven, the longer the cooking time. Remember to decrease cooking times by at least one third when halving a recipe.

Shape of food

Microwaves penetrate only about 2.cm into food, the interior portion of thick foods are cooked as the heat generated on the outside travels inward. Only the outer edge of food is cooked by microwave energy; the rest is cooked by conduction. The worst possible shape for a food that is to be microwaved is a thick square. The corners will burn long before the centre is even warm. Round thin foods and ring shaped foods cook successfully in the microwave.

Covering

A cover traps heat and steam which causes food to cook more quickly. Use a lid or microwave cling film with a corner folded back to prevent splitting.

Browning

Meats and poultry that are cooked fifteen minutes or longer will brown lightly in their own fat. Food that are cooked for a shorter period of time may be brushed with a browning sauce such as worcestershire sauce, soy sauce or barbecue sauce to achieve an appetizing colour. Since relatively small amounts of browning sauces are added to food the original flavour of the recipe is not altered.

Covering with greaseproof paper

Greaseproofing effectively prevents spattering and helps food retain some heat. But because it makes a looser cover than a lid or clingfilm, it allows the food to dry out slightly.

Arranging and spacing

Individual foods such as baked potatoes, small cakes and hors d'oeuvres will heat more evenly if placed in the oven an equal distance apart, preferably in a circular pattern. Never stack foods on top of one another.

Food characteristics & Microwave cooking

Stirring

Stirring is one of the most important of all microwaving techniques. In conventional cooking, food is stirred for the purpose of blending. Microwaved food, however, is stirred in order to spread and redistribute heat. Always stir from the outside towards the centre as the outside of the food heats first.

Turning over

Large, tall foods such as roasts and whole chickens should be turned so that the top and bottom will cook evenly. It is also a good idea to turn cut up chicken and chops.

Placing thicker portions facing outwards

Since microwaves are attracted to the outside portion of food, it makes sense to place thicker portions of meat, poultry and fish to the outer edge of the baking dish. This way, thicker portions will receive the most microwave energy and the food will cook evenly.

Shielding

Strips of aluminium foil (which block microwaves) can be placed over the corners or edges of square and rectangular foods to prevent those portions from overcooking. Never use too much foil and make sure the foil is secured to the dish or it may cause 'arcing' in the oven.

Elevating

Thick or dense foods can be elevated so that microwaves can be absorbed by the underside and centre of the foods.

Piercing

Foods enclosed in a shell, skin or membrane are likely to burst in the oven unless they are pierced prior to cooking. Such foods include yolks and whites of eggs, clams and oysters and whole vegetables and fruits.

Testing if cooked

Food cooks so quickly in an oven, it is necessary to test it frequently. Some foods are left in the microwave until completely cooked, but most foods, including meats and poultry, are removed from the oven while still slightly undercooked and allowed to finish cooking during standing time. The internal temperature of foods will rise between 5°F (3°C) and 15°F (8°C) during standing time.

Standing time

Foods are often allowed to stand for 3 to 10 minutes after being removed from the oven. Usually the foods are covered during standing time to retain heat unless they are supposed to be dry in texture (some cakes and biscuits, for example). Standing allows foods to finish cooking and also helps flavour blend and develop.

To Clean Your Oven

1. Keep the inside of the oven clean

Food spatters or spilled liquids stick to oven walls and between seal and door surface. It is best to wipe up spillovers with a damp cloth right away. Crumbs and spillovers will absorb microwave energy and lengthen cooking times. Use a damp cloth to wipe out crumbs that fall between the door and the frame. It is important to keep this area clean to assure a tight seal. Remove greasy spatters with a soapy cloth then rinse and dry. Do not use harsh detergent or abrasive cleaners. The metal tray can be washed by hand or in the dishwasher.

2. Keep the outside of the oven clean

Clean the outside of your oven with soap and water then with clean water and dry with a soft cloth or paper towel. To prevent damage to the operating parts inside the oven, the water should not be allowed to seep into the ventilation openings. To clean control panel, open the door to prevent oven from accidentally starting, and wipe a damp cloth followed immediately by a dry cloth. Press Stop/Clear after cleaning.

3. If steam accumulates inside or around the outside of the oven door, wipe the panels with a soft cloth. This may occur when the oven is operated under high humidity conditions and in no way indicates a malfunction of the unit.

4. The door and door seals should be kept clean. Use only warm, soapy water, rinse then dry thoroughly.

DO NOT USE ABRASIVE MATERIALS, SUCH AS CLEANING POWDERS OR STEEL AND PLASTIC PADS.

Metal parts will be easier to maintain if wiped frequently with a damp cloth.

5. Do not use any steam cleaner.

6. Unplug your oven from the electrical socket when you clean control panel with wet cloth or spray water on control glass to clean. If it's not, this product can be operated by touching Quick Start button.

Questions & Answers

Q What's wrong when the oven light will not glow?

A There may be several reasons why the oven light will not glow.
Light bulb has blown
Relay is failed

Q Does microwave energy pass through the viewing screen in the door?

A No. The holes, or ports, are made to allow light to pass; they do not let microwave energy through.

Q Why does the beep tone sound when a button on the Control Panel is touched?

A The beep tone sounds to assure that the setting is being properly entered.

Q Will the microwave function be damaged if it operates empty?

A Yes Never run it empty.

Q Why do eggs sometimes pop?

A When baking, frying, or poaching eggs, the yolk may pop due to steam build up inside the yolk membrane. To prevent this, simply pierce the yolk before cooking. Never microwave eggs in the shell.

Q Why is standing time recommended after microwave cooking is over?

A After microwave cooking is finished, food keeps on cooking during standing time. This standing time finishes cooking evenly throughout the food. The amount of standing time depends on the density of the food.

Q Why doesn't my oven always cook as fast as the cooking guide says?

A Check your cooking guide again to make sure you've followed directions correctly, and to see what might cause variations in cooking time. Cooking guide times and heat settings are suggestions, chosen to help prevent overcooking, the most common problem in getting used to a this oven. Variations in the size, shape, weight and dimensions of the food require longer cooking time. Use your own judgement along with the cooking guide suggestions to test food condition, just as you would do with a conventional cooker.

Technical Specifications

Technical Specification

		MP9287NL
Power Input		230 V~ 50 Hz
Output		700 W (IEC60705 rating standard)
Microwave Frequency		2450 MHz
Outside Dimension		527 mm(W) X 366 mm(H) X 472 mm(D)
Power	Microwave	1300 watt
	Grill	1900 watt
Consumption	Convection	2200 watt
	Combination	max. 2700 watt

- Microwave Frequency : 2450 MHz +/- 50 MHz (Group 2 / Class B)
**** Group 2 equipment:** group 2 contains all ISM RF equipment in which radio-frequency energy in the frequency range 9 kHz to 400GHz is intentionally generated and used or only used, in the form of electromagnetic radiation, inductive and /or capacitive coupling, for the treatment of material or inspection/analysis purposes. Class B equipment is equipment suitable for use in domestic establishments and in establishments directly connected to a low voltage power supply network which supplies buildings used for domestic purposes.

- You can download a owner's manual at <http://www.lg.com>.

Memo



Printed in Korea