



# OWNER'S MANUAL LIGHT OVEN “Steam **SolarCUBE**™”

Please read this owner's manual thoroughly before operating. The manufacturers are not liable for any problems caused by The user's failure to observe these instructions.

MP9289VSD



MFL30207327

[www.lg.com](http://www.lg.com)

# Contents

## How the Microwave Function Works

Microwaves are a form of energy similar to radio and television waves and ordinary daylight. Normally, microwaves spread outwards as they travel through the atmosphere and disappear without effect. This oven, however, has a magnetron which is designed to make use of the energy in microwaves. Electricity, supplied to the magnetron tube, is used to create microwave energy.

These microwaves enter the cooking area through openings inside the oven. A tray is located inside the oven. Microwaves cannot pass through metal walls of the oven, but they can penetrate such materials as glass, porcelain and paper, the materials out of which microwave-safe cooking dishes are constructed.

Microwaves do not heat cookware, though cooking vessels will eventually get hot from the heat generated by the food.

## A very safe appliance

Your oven, SolarCUBE, is one of the safest of all home appliances. When the door is opened, the oven automatically stops producing microwaves. Microwave energy is converted completely to heat when it enters food, leaving no "left over" energy to harm you when you eat your food.

Contents	2
Important safety instructions	3 ~ 15
Precautions	16
Unpacking & Installing	17 ~ 18
Control Panel	19
Setting the Clock	20
Child Lock	21
Micro Power Cooking	22
Micro Power Level	23
Grill Cooking	24
Grill Combi Cooking	25
Convection Preheat	26
Convection Cooking	27
Convection Combi Cooking	28
For Steam+ cooking	29
Micro Power Steam+ Cooking	30 ~ 31
Convection Steam+ Cooking	32 ~ 33
Steam+	34 ~ 35
Auto Cooking	36 ~ 44
Steam+ Auto Cooking	45 ~ 49
Defrost	50
Defrost Guide	51
Defrost Steam+	52
Defrost Steam+ Guide	53
Steam Multi clean	54
Ez Clean	55
Quick Start	56
More or Less Cooking	57
How To Clean	58
Microwave - safe Utensils	59
Food characteristics & Microwave cooking	60 ~ 61
Questions & Answers	62
Technical Specifications	63

Please keep for future reference. Read and follow all instructions before using your oven to prevent the risk of fire, electric shock, personal injury, or damage when using the oven. This guide do not cover all possible conditions that may occur. Always contact your service agent or manufacturer about problems that you do not understand.

## ***Important Safety*** **Instructions**



This is the safety alert symbol. This symbol alerts you to potential hazards that can kill or hurt you and others.

All safety messages will follow the safety alert symbol and either the word “WARNING” or “CAUTION”. These word means :

**⚠ WARNING:** This symbol will alert you to hazards or unsafe practices which could cause serious bodily harm or death.

**⚠ CAUTION:** This symbol will alert you to hazards or unsafe practices which could cause bodily injury or property damage.

# Important Safety

## Instructions

Please keep for future reference. Read and follow all instructions before using your oven to prevent the risk of fire, electric shock, personal injury, or damage when using the oven. This guide do not cover all possible conditions that may occur. Always contact your service agent or manufacturer about problems that you do not understand.

### WARNING

- 1. Do not attempt to tamper with, or make any adjustments or repairs to the door, door seals, control panel, safety interlock switches or any other part of the oven. which involves the removal of any cover which gives protection against exposure to microwave energy. Do not operate the oven, if the door seals and adjacent parts of the microwave oven are faulty. Repairs should only be undertaken by a qualified service technician.**
- Unlike other appliances, the microwave oven is high-voltage and high-current

- equipment. Improper use or repair could result in harmful exposure to excessive microwave energy or an electric shock.
- 2. Do not use the oven for the purpose of dehumidification. (ex. Operating the microwave oven with the wet newspapers, clothes, toys, electric devices, pet or child etc.)**
- It can be the cause of serious damage of safety such as a fire, a burn or a sudden death due to an electric shock.

Please keep for future reference. Read and follow all instructions before using your oven to prevent the risk of fire, electric shock, personal injury, or damage when using the oven. This guide do not cover all possible conditions that may occur. Always contact your service agent or manufacturer about problems that you do not understand.

## ***Important Safety*** **Instructions**

### **⚠ WARNING**

- 3. The appliance and its accessible parts become hot during use. Care should be taken to avoid touching heating elements. Children less than 8 years of age shall be kept away unless continuously supervised.**
- 4. The appliance is not intended for use by young children or infirm persons. Only allow children to use the oven without supervision when adequate instructions have been given so that the child is able to use the oven in a safe way and understands the hazards of improper use.**

- ➡ Improper use may cause the damage of safety concerns such as a fire, an electric shock and a burn.**
- 5. Accessible parts may become hot during use. Young children should be kept away.**
  - ➡ They may get a burn.**
- 6. Liquids or other foods must not be heated in sealed containers since they are liable to explode. Remove the plastic wrapping from food before cooking or defrosting. Note though that in some cases food should be covered with plastic film, for heating or cooking.**
  - ➡ They could burst.**

# ***Important Safety***

## **Instructions**

Please keep for future reference. Read and follow all instructions before using your oven to prevent the risk of fire, electric shock, personal injury, or damage when using the oven. This guide do not cover all possible conditions that may occur. Always contact your service agent or manufacturer about problems that you do not understand.

### **WARNING**

- 7. This appliance is not intended for use by persons (including children) with reduced physical, sensory or mental capabilities, or lack of experience and knowledge, unless they have been given supervision or instruction concerning use of the appliance by a person responsible for their safety.**
- 8. When the appliance is operated in the combination mode, children should only use the oven under adult supervision due to the temperatures generated.**

Please keep for future reference. Read and follow all instructions before using your oven to prevent the risk of fire, electric shock, personal injury, or damage when using the oven. This guide do not cover all possible conditions that may occur. Always contact your service agent or manufacturer about problems that you do not understand.

# **Important Safety Instructions**

## **⚠ CAUTION**

- 1. You cannot operate your oven with the door open due to the safety interlocks built into the door mechanism. It is important not to tamper with the safety interlock.**
  - ➡ It could result in harmful exposure to excessive microwave energy. (Safety interlocks automatically switch off any cooking activity when the door is opened.)
- 2. Do not place any object (such as kitchen towel, napkin, etc.) between the oven front face and the door or allow food or cleaner residue to accumulate on sealing surfaces.**

- ➡ It could result in harmful exposure to excessive microwave energy.
- 3. Do not operate your oven if it is damaged. It is particularly important that the oven door closes properly and that there is no damage to the: (1) door(bent), (2) hinges and latches (broken or loosened), (3) door seals and sealing surfaces.**
    - ➡ It could result in harmful exposure to excessive microwave energy.

# Important Safety

## Instructions

Please keep for future reference. Read and follow all instructions before using your oven to prevent the risk of fire, electric shock, personal injury, or damage when using the oven. This guide do not cover all possible conditions that may occur. Always contact your service agent or manufacturer about problems that you do not understand.

### CAUTION

**4. Please ensure cooking times are correctly set small amounts of food require shorter cooking or heating time.**

➡ The over cooking may result in the food catching a fire and subsequent damage to your oven.

**5. When heating liquids, e.g. soups, sauces and beverages in your microwave oven,**

**\* Avoid using straight sided containers with narrow necks.**

**\* Do not overheat.**

**\* Stir the liquid before placing the container in the oven and again halfway through the heating time.**

**\* After heating, allow to stand in the oven for a short time, stir or shake them again carefully and check the temperature of them before consumption to avoid burns (especially, contents of feeding bottles and baby food jars).**

➡ Be careful when handling the container. Microwave heating of beverages can result in delayed eruptive boiling without evidence of bubbling. This could result in a sudden boil over of the hot liquid.



Please keep for future reference. Read and follow all instructions before using your oven to prevent the risk of fire, electric shock, personal injury, or damage when using the oven. This guide do not cover all possible conditions that may occur. Always contact your service agent or manufacturer about problems that you do not understand.

## ***Important Safety*** **Instructions**

### **⚠ CAUTION**

**6. An exhaust outlet is located on top or bottom or side of the oven. Don't block the outlet.**

➡ It could result in damage to your oven and poor cooking results.

**7. Do not operate the oven when empty. It is best to leave a glass of water in the oven when not in use. The water will safely absorb all microwave energy, if the oven is accidentally started.**

➡ Improper use could result in damage to your oven.

**8. Do not cook food wrapped in paper towels, unless your cook book contains instructions for the food you are cooking. And do not use newspaper in place of paper towels for cooking.**

➡ Improper use can be the cause of an explosion or a fire.

**9. Do not use wooden containers and ceramic containers which have metallic (e.g. gold or silver) inlays. Always remove metal twist ties. Check the utensils are suitable for use in microwave ovens before use.**

➡ They may heat-up and char. Especially metal objects in the oven may arc, which can cause serious damage.

# Important Safety

## Instructions

Please keep for future reference. Read and follow all instructions before using your oven to prevent the risk of fire, electric shock, personal injury, or damage when using the oven. This guide do not cover all possible conditions that may occur. Always contact your service agent or manufacturer about problems that you do not understand.

### CAUTION

#### **10. Do not use recycled paper products.**

- They may contain impurities which may cause sparks and/or fires when used in cooking.

#### **11. Do not rinse the tray and rack by placing it in water just after cooking. This may cause breakage or damage.**

- Improper use could result in damage to your oven.

#### **12. Be certain to place the oven so the front of the door is 8 cm or more behind the edge of the surface on which it is placed, to avoid accidental tipping of the appliance.**

- Improper use could result in bodily injury and oven damage.

#### **13. Before cooking, pierce the skin of potatoes, apples or any such fruit or vegetable.**

- They could burst.

#### **14. Do not cook eggs in their shell. Eggs in their shell and whole hardboiled eggs should not be heated in microwave ovens since they may explode, even after microwave heating has ended.**

- Pressure will build up inside the egg which will burst.

Please keep for future reference. Read and follow all instructions before using your oven to prevent the risk of fire, electric shock, personal injury, or damage when using the oven. This guide do not cover all possible conditions that may occur. Always contact your service agent or manufacturer about problems that you do not understand.

# ***Important Safety*** **Instructions**

## **⚠ CAUTION**

### **15. Do not attempt deep fat frying in your oven.**

- This could result in a sudden boil over of the hot liquid.

### **16. If smoke is observed (or emitted), switch off or disconnect the oven from the power supply and keep the oven door closed in order to stifle any flames.**

- It can be the cause of serious damage of safety such as a fire, an electric shock.

### **17. When food is heated or cooked in disposable containers of plastic, paper or other combustible materials, keep an eye on the oven and check it frequently.**

- Your food may be poured due to the possibility of container deterioration, which also can cause a fire.

### **18. The temperature of accessible surfaces may be high when the appliance is operating. Do not touch the oven door, outer cabinet, rear cabinet, oven cavity, accessories and dishes during grill mode, convection mode and auto cook operations, before clearing make sure they are not hot.**

- As they will become hot, unless wearing thick oven gloves there is the danger of a burn.

# Important Safety

## Instructions

Please keep for future reference. Read and follow all instructions before using your oven to prevent the risk of fire, electric shock, personal injury, or damage when using the oven. This guide do not cover all possible conditions that may occur. Always contact your service agent or manufacturer about problems that you do not understand.

### CAUTION

**19. The oven should be cleaned regularly and any food deposits removed.**

➤ Failure to maintain the oven in a clean condition could lead to deterioration of the surface that could adversely affect the life of the appliance and possibly result in a hazardous situation.

**20. Only use the temperature probe recommended for this oven (for appliances having a facility to use a temperature-sensing probe).**

➤ You can not ascertain that the temperature is accurate with unsuitable temperature probe.

**21. If heating elements are provided, during use the appliance becomes hot. Care should be taken to avoid touching heating elements inside the oven.**

➤ There is the danger of a burn.

**22. Follow exact directions given by each manufacturer for their popcorn product. Do not leave the oven unattended while the corn is being popped. If corn fails to pop after the suggested times, discontinue cooking. Never use a brown paper bag for popping corn. Never attempt to pop leftover kernels.**

➤ Overcooking could result in the corn catching a fire.

Please keep for future reference. Read and follow all instructions before using your oven to prevent the risk of fire, electric shock, personal injury, or damage when using the oven. This guide do not cover all possible conditions that may occur. Always contact your service agent or manufacturer about problems that you do not understand.

# Important Safety Instructions

## CAUTION

### 23. This appliance must be earthed.

The wires in this mains lead are colored in accordance with the following codes

**BLUE ~ Neutral**

**BROWN ~ Live**

**GREEN & YELLOW ~ Earth**

As the colours of the wires in the mains lead of this appliance may not correspond with the coloured markings identifying the terminals in your plug proceed as follows:

The wire which is colored **BLUE** must be connected to the terminal which is

marked with the letter **N** or Colored **BLACK**.

The wire which is colored **BROWN** must be connected to the terminal which is marked with the letter **L** or colored **RED**.

The wire which is colored **GREEN & YELLOW** or **GREEN** must be connected to the terminal which is marked with the letter **E** or  $\perp$ .

If the supply cord is damaged, it must be replaced by the manufacturer or its service agent or a similarly qualified person in order to avoid a hazard.

 Improper use may cause serious electric damage.

# ***Important Safety***

## **Instructions**

Please keep for future reference. Read and follow all instructions before using your oven to prevent the risk of fire, electric shock, personal injury, or damage when using the oven. This guide do not cover all possible conditions that may occur. Always contact your service agent or manufacturer about problems that you do not understand.

### **⚠ CAUTION**

**24. Do not use harsh abrasive cleaners or sharp metal scrapers to clean the oven door glass.**

➡ They can scratch the surface, which may result in shattering of the glass.

**25. This oven should not be used for commercial catering purposes.**

➡ Improper use could result in damage to your oven.

**26. The microwave oven must be operated with the door of built-in cabinet open.**

➡ If the door of cabinet is closed while operating, the airflow get worse and it could result in a fire or damage to your oven and the cabinet.

**27. The connection may be achieved by having the plug accessible or by incorporation a switch in the fixed wiring in accordance with the wiring rules.**

➡ Using improper plug or switch can cause an electric shock or a fire.

**28. This appliance is not intended for use by persons (including children) with reduced physical, sensory or mental capabilities, or lack of experience and knowledge, unless they have been given supervision or instruction concerning use of the appliance by a person responsible for their safety.**

Please keep for future reference. Read and follow all instructions before using your oven to prevent the risk of fire, electric shock, personal injury, or damage when using the oven. This guide do not cover all possible conditions that may occur. Always contact your service agent or manufacturer about problems that you do not understand.

## ***Important Safety*** **Instructions**

### **⚠ CAUTION**

- 29. (Young)Children should be supervised to ensure that they do not play with the appliance.**
- 30. This appliance can be used by children aged from 8 years and above and persons with reduced physical, sensory or mental capabilities or lack of experience and knowledge if they have been given supervision or instruction concerning use of the appliance in a safe way and understand the hazards involved. Children shall not play with the appliance. Cleaning and user maintenance shall not be undertaken by children without supervision.**
- 31. The appliance is not intended to be operated by means of an external timer or separate remote-control system.**
- 32. The contents of feeding bottles and baby food jars shall be stirred or shaken and the temperature checked before consumption, in order to avoid burns.**
- 33. Steam cleaner is not to be used.**

# Precautions

## Precautions to avoid possible exposure to excessive microwave energy.

You cannot operate your oven with the door open due to the safety interlocks built into the door mechanism. These safety interlocks automatically switch off any cooking activity when the door is opened; which in the operation of microwave function could result in harmful exposure to microwave energy.

**It is important not to tamper with the safety interlocks.**

Do not place any object between the oven front face and the door or allow food or cleaner residue to accumulate on sealing surfaces.

Do not operate your oven if it is damaged. It is particularly important that the oven door closes properly and that there is no damage to the: (1) door(bent), (2) hinges and latches (broken or loosened), (3) door seals and sealing surfaces.

Your oven should not be adjusted or repaired by anyone except qualified service personnel.

### **WARNING**

**Please ensure cooking times are correctly set as over cooking may result in the FOOD catching fire and subsequent damage to your oven.**

When heating liquids, e.g. soups, sauces and beverages in your oven with microwave function, delayed eruptive boiling can occur without evidence of bubbling. This could result in a sudden boil over of the hot liquid. To prevent this possibility the following steps should be taken:

- 1 Avoid using straight sided containers with narrow necks.
- 2 Do not overheat.
- 3 Stir the liquid before placing the container in the oven and again halfway through the heating time.
- 4 After heating, allow to stand in the oven for a short time, stir or shake them(especially the contents of feeding bottles and baby food jars) again carefully and check the temperature of them before consumption to avoid burns (especially, contents of feeding bottles and baby food jars).  
Be careful when handling the container.

### **WARNING**

**Always allow food to stand after being cooked by microwaves and check the temperature of them before consumption. Especially contents of feeding bottles and baby food jars.**



# Unpacking & Installing

By following the basic steps on these two pages you will be able to quickly check that your oven is operating correctly. Please pay particular attention to the guidance on where to install your oven. When unpacking your oven make sure you remove all accessories and packing. Check to make sure that your oven has not been damaged during delivery.

**1** Unpack your oven and place it on a flat level surface.

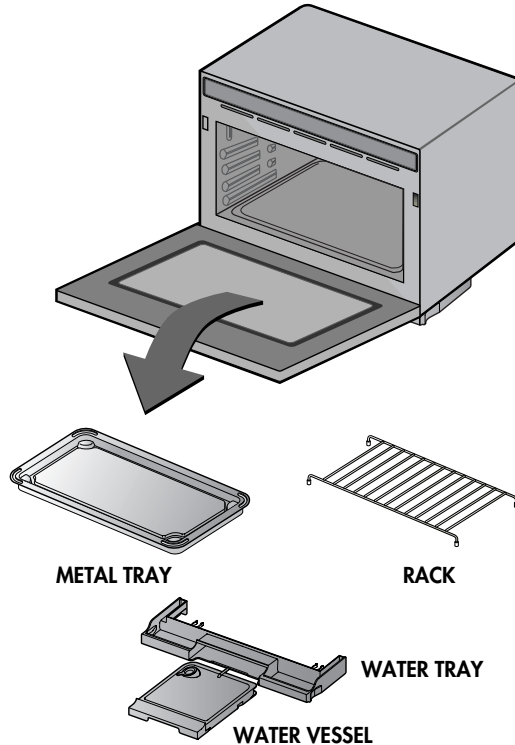

**2** Place the oven in the level location of your choice with more than 85cm height but make sure there is at least 20cm of space on the top and 10cm at the rear for proper ventilation. The front of the oven should be at least min. 8cm/max. 22cm from the edge of the surface to prevent tipping. An exhaust outlet is located on bottom or side of the oven. Blocking the outlet can damage the oven.

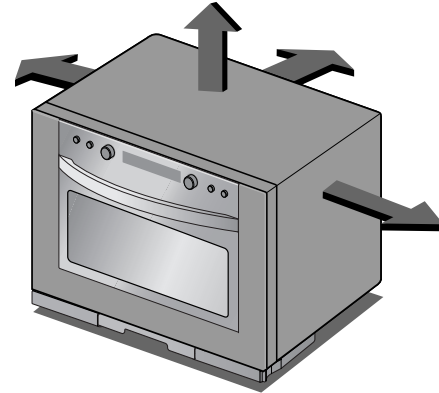

**\* THIS OVEN SHOULD NOT BE USED FOR COMMERCIAL CATERING PURPOSES.**

**3** Plug your oven into a standard household socket. Make sure your oven is the only appliance connected to the socket. **If your oven does not operate properly, unplug it from the electrical socket and then plug it back in.**

**4** Open your oven door by pulling the **DOOR HANDLE**. Place the **RACK** inside the oven.

**5** Fill a **microwave safe container** with 300 ml (1/2 pint) of water. Place on the rack on the oven bottom surface and close the oven door. If you have any doubts about what type of container to use please refer to page 59.

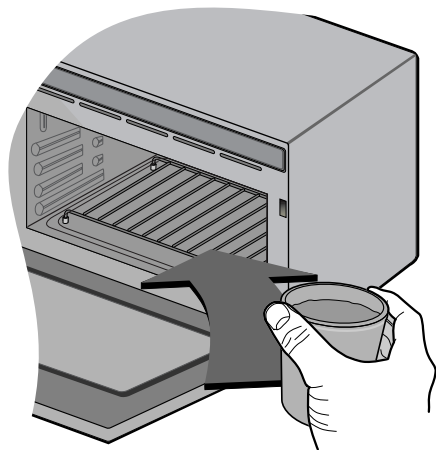

**6** Press the **STOP/CLEAR** button, and press the **ENTER/START/Q-START** button one time to set 30 seconds of cooking time.



**7** The **DISPLAY** will count down from 30 seconds. When it reaches 0 it will sound BEEPS. Open the oven door and test the temperature of the water. If your oven is operating the water should be warm. **Be careful when removing the container it may be hot.**



#### **YOUR OVEN IS NOW INSTALLED**

**8** The contents of feeding bottles and baby food jars shall be stirred or shaken and the temperature checked before consumption, in order to avoid burns.

# Control Panel

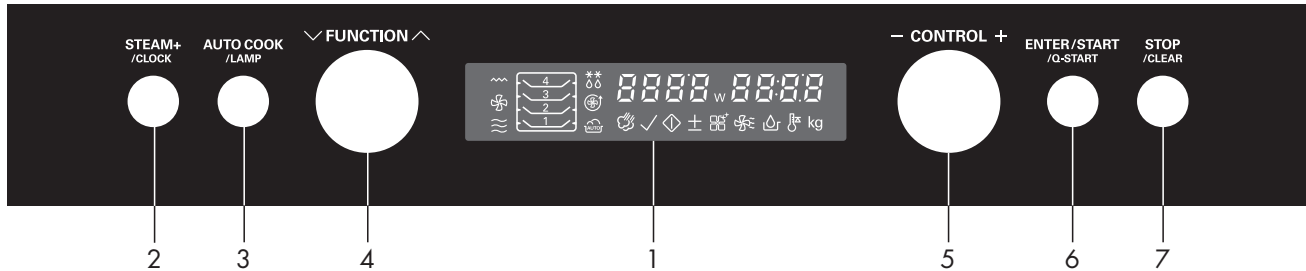

**1. DISPLAY WINDOW:** You can show time of day, cooking time, power level and cooking categories.

**2. STEAM+/CLOCK**

- **STEAM+:** You can add steam.
- **CLOCK:** You can set the time of day.

**3. AUTO COOK/LAMP**

- **AUTO COOK:** Auto Cook allows you to cook most of your favorite food quickly by selecting the food type and the weight of the food.
- **LAMP:** You can see the foods while cooking by pressing this button.

**4. FUNCTION SELECT:** You can select cooking categories.

**5. CONTROL:**

- You can set cooking times, temperature, weight and cooking categories.
- While cooking with auto and manual function, you can lengthen or shorten the cooking time at any point by turning the dial (except defrost mode).

**6. ENTER/START/Q-START:**

- In order to start cooking which is selected, press button one time.
- The quick start feature allows you to set 30 seconds intervals of HIGH power cooking with a touch of the quick start button.

**7. STOP/CLEAR:** You can stop over and clear all entries except time of day.

# Setting the Clock



When your oven is plugged in for the first time or when power resumes after a power cut, a '0' will be shown in the display; you will have to reset the clock.

If the clock (or display) shows any strange looking symbols, unplug your oven from the electrical socket and plug it back in and reset the clock.

You can set either 12 hour clock or 24 hour clock.  
In the following example I will show you how to set the time for 10:30 when using the 24 clock.  
Make sure that you have removed all packaging from your oven.

Make sure that you have correctly installed your oven as described earlier in this book.

Press **STOP/CLEAR**.

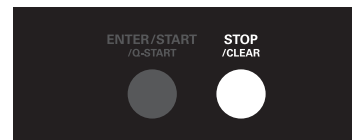

Press **STEAM+/CLOCK** for 2sec.

(If you want to use a 12 hour clock, Turn **CONTROL dial**.  
If you want to change different option after setting clock, you have to unplug and plug it back in.)

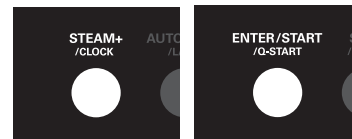

Press **ENTER/START/Q-START**.

Turn **CONTROL dial** until display shows "10:00".

Press **ENTER/START/Q-START** for hour confirmation

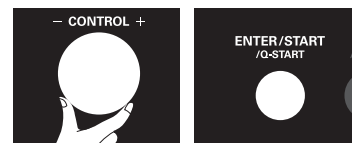

Turn **CONTROL dial** until display shows "10:30".

Press **ENTER/START/Q-START**.

The clock starts counting.

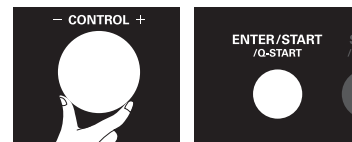

# Child Lock



Your oven has a safety feature that prevents accidental running of the oven. Once the child lock is set, you will be unable to use any functions and no cooking can take place. However your child can still open the oven door.

Press **STOP/CLEAR**.



Press and hold **STOP/CLEAR** until "L" appears on the display and BEEP sounds.

The **CHILD LOCK** is now set.



The time will disappear on the display but will reappear on the display a few seconds later.

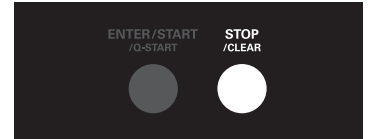

If any button is pressed, "L" will appear on the display



To cancel **CHILD LOCK** press and hold **STOP/CLEAR** until "L" disappears. You will hear BEEP when it's released.



# Micro Power Cooking

In the following example I will show you how to cook some food on 450W power for 5 minutes.



Your oven has five microwave Power settings. High power is automatically selected and pressing on control will select a different power level.

POWER	
<b>HIGH</b>	700 W
<b>MEDIUM HIGH</b>	450 W
<b>MEDIUM</b>	300 W
<b>DEFROST</b>	
<b>MEDIUM LOW</b>	180 W
<b>LOW</b>	90 W

Make sure that you have correctly installed your oven as described earlier in this book.

Press **STOP/CLEAR**.

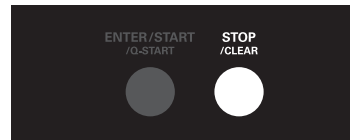

Turn **FUNCTION selection dial** to select **Microwave**.

The following indication is displayed: "≐"



Turn **CONTROL dial** until display shows "450W".

Press **ENTER/START/Q-START** for power confirmation.

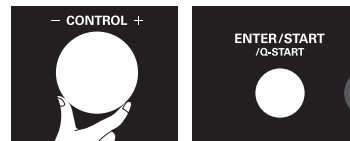

Turn **CONTROL dial** until display shows "5:00".

Press **ENTER/START/Q-START**.

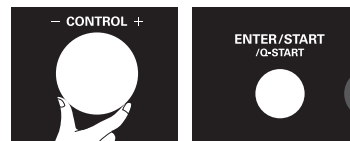

# Micro Power Level

This oven is equipped with 5 power levels to give you maximum flexibility and control over cooking.  
The table below shows the examples of food and their recommended cooking power levels for use with this oven.

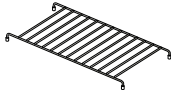
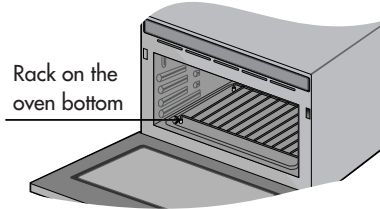
POWER LEVEL	OUTPUT	USE	ACCESSORY
HIGH	700W	<ul style="list-style-type: none"> <li>* Boil Water</li> <li>* Brown minced beef</li> <li>* Cook poultry pieces, fish, vegetables</li> <li>* Cook tender cuts of meat</li> </ul>	Rack   * Rack Location  
MEDIUM HIGH	450W	<ul style="list-style-type: none"> <li>* All reheating</li> <li>* Roast meat and poultry</li> <li>* Cook mushrooms and shellfish</li> <li>* Cook foods containing cheese and eggs</li> </ul>	
MEDIUM	300W	<ul style="list-style-type: none"> <li>* Bake cakes and scones</li> <li>* Prepare eggs</li> <li>* Cook custard</li> <li>* Prepare rice, soup</li> </ul>	
DEFROST/ MEDIUM LOW	180W	<ul style="list-style-type: none"> <li>* All thawing</li> <li>* Melt butter and chocolate</li> <li>* Cook less tender cuts of meat</li> </ul>	
LOW	90W	<ul style="list-style-type: none"> <li>* Soften butter &amp; cheese</li> <li>* Soften ice cream</li> <li>* Raise yeast dough</li> </ul>	



**Note:**

The feeding bottles should not be on rack during operating.  
This situation can make a damage of feeding bottles' bottom.  
The feeding bottles should be operated on Metal tray located at level 1 inside cavity.

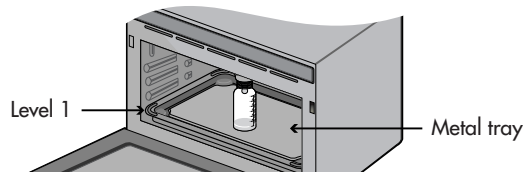

# Grill Cooking

In the following example I will show you how to use the Grill to cook some food for 12 minutes.



This feature will allow you to brown and crisp food quickly.

**The rack in Metal tray must be used during grill cooking.**

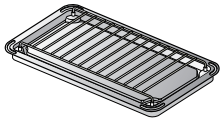

\* Tray Location

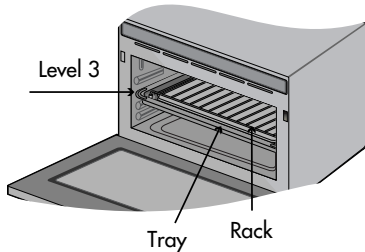

Press **STOP/CLEAR**.



Turn **FUNCTION selection dial** to select **Grill**.

The following indication is displayed: "∞∞∞"



Turn **CONTROL dial** until display shows "12:00".



Press **ENTER/START/Q-START**.

**After cooking you must wear heat proof oven gloves to take metal tray out of the oven as the tray and its contents will be very hot.**

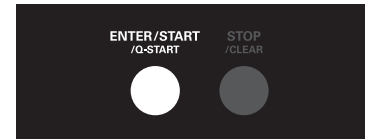
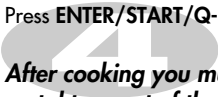



# Grill combi Cooking

In the following example I will show you how to programme your oven with micro power 300W and grill for a cooking time of 25 minutes.

Your oven has a combination cooking feature which allows you to cook food with **heater** and **microwave**. This generally means it takes less time to cook your food.

You can set four kinds of micro power level (90W, 180W, 300W and 450W) in grill combi mode.

**The rack in Metal tray must be used during grill combi. cooking.**

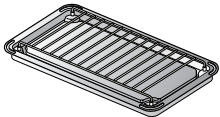

\* Tray Location

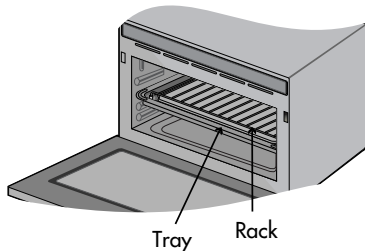

Press **STOP/CLEAR**.

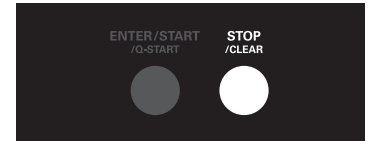

Turn **FUNCTION** selection dial to select **Grill Combi**.

The following indications are displayed: " ≈ ", " ≈ ≈ ".



Turn **CONTROL** dial until display shows "300W".

Press **ENTER/START/Q-START** for power confirmation.

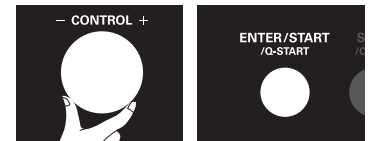

Turn **CONTROL** dial until display shows "25:00".



Press **ENTER/START/Q-START**.

**After cooking you must wear heat proof oven gloves to take metal tray out of the oven as the tray and its contents will be very hot.**

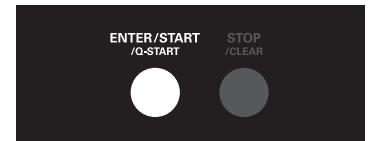

# Convection Preheat

In the following example I will show you how to preheat the oven at a temperature of 200°C.



The convection oven has a temperature range of 40 °C and 100 °C~230 °C (180 °C is automatically available when convection mode is selected).

The oven has a ferment function at the oven temperature of 40 °C. You may wait until the oven is cool because you cannot use a ferment function if the oven temperature is over 40 °C.

Your oven will take a few minutes to reach the selected temperature.

Once it has reached correct temperature, your oven will BEEP to let you know that it has reached the correct temperature.

Then place your food in your oven: then tell your oven to start cooking.

Press **STOP/CLEAR**.

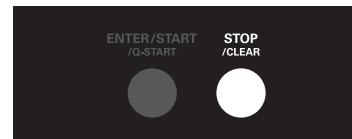

Turn **FUNCTION selection dial** to select **Conv.**

The following indication is displayed: "  "



Turn **CONTROL dial** until display shows "200°C".

Press **ENTER/START/Q-START** for temperature confirmation.

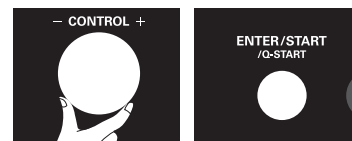

Press **ENTER/START/Q-START**.

Preheating will be started with displaying "Pr-H".

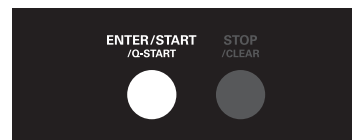

# Convection Cooking

In the following example I will show you how to preheat the oven first, then cook some food at a temperature of 230°C for 50 minutes.



If you do not set a temperature your oven will automatically select 180°C, the cooking temperature can be changed by turning **CONTROL dial**.

**The Metal tray must be used during convection cooking.**

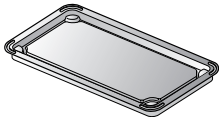

\* Tray Location

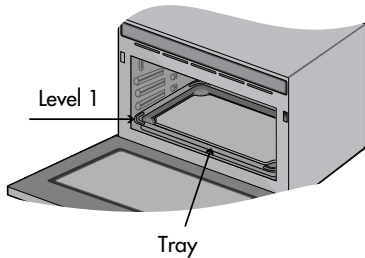

Press **STOP/CLEAR**.

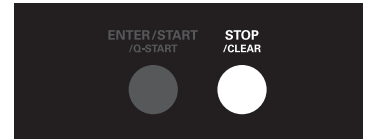

Turn **FUNCTION selection dial** to select **Conv.**

The following indication is displayed: "☼"



Turn **CONTROL dial** until display shows "230°C".

Press **ENTER/START/Q-START** for temperature confirmation.

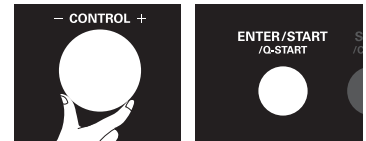

Turn **CONTROL dial** until display shows "50:00".



Press **ENTER/START/Q-START**.

When cooking you can increase or decrease cooking time by turning **CONTROL dial**.

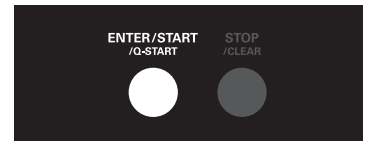

# Convection combi

## Cooking

In the following example I will show you how to programme your oven with micro power 300W and at a temperature 200°C for a cooking time of 25 minutes.



You can set four kinds of micro power level (90W, 180W, 300W and 450W) in convection combi mode.

The rack in Metal tray must be used during Convection combi. cooking.

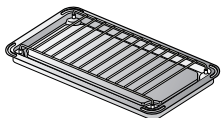

### \* Tray Location

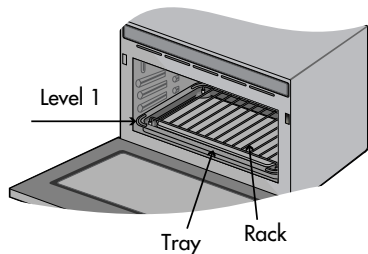

Press **STOP/CLEAR**.

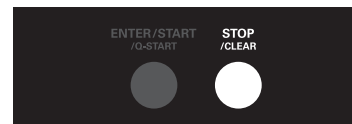

Turn **FUNCTION** selection dial to select **Conv. Combi**.

The following indications are displayed: " ≈ ", " ✻ ".



Turn **CONTROL** dial until display shows "200°C".

Press **ENTER/START/Q-START** for temperature confirmation.



Turn **CONTROL** dial until display shows "300W".

Press **ENTER/START/Q-START** for power confirmation.

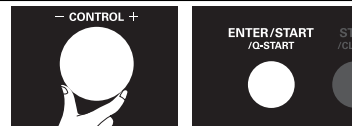

Turn **CONTROL** dial until display shows "25:00".



Press **ENTER/START/Q-START**.

**After cooking you must wear heat proof oven gloves to take metal tray out of the oven as the tray and its contents will be very hot.**

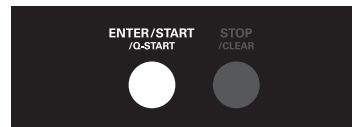

# For Steam+ Cooking

- ◆ In case of Steam cooking, Set the time **at least 2 min.**



- ◆ Before Steam cooking, clean up the water vessel and fill it with water by **MAX.**

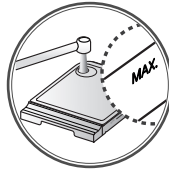

- ◆ If Display shows "☒" with the melody, check the water vessel whether it needs water or it's installed exactly.



- ◆ After finishing steam cooking, please use Drain water Function, because there is possibility some water remains in the steam generator. (Refer to 54p for more information about **Drain water Function**)

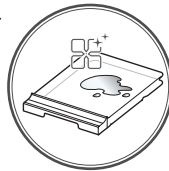

- ◆ When cooking with steam often, you might see scale in a cavity because of calcium, magnesium included in water, this does not harm human body. In this situation, you can remove it effectively, if you wipe it with wet towel with **vinegar**.



- ◆ Don't fill it with **hot water**.



*\* Please read carefully, before using steam function.*

## **CAUTION OF USING WATER VESSEL.**

- Do not use it with any fluid or mixture other than water.
- Use only potable water (purified).
- Do not fill it with hot water.
- Fill the water vessel up to the line indicated on the side.
- Do not tilt the water vessel filled with water.
- Make sure to pour water out and clean the water vessel after cooking.
- Do not use the water vessel in any other way except for providing water for steam cooking.
- If you use it for over 30 minutes, re-fill the water vessel with water within 30 minutes from the start of cooking.

# Micro Power Steam+ Cooking

In the following example I will show you how to use the Micro Power Steam+ Cooking mode to cook some foods on 450W power for 5 minutes.



Your oven has five microwave Power settings. High power is automatically selected and pressing on control will select a different power level.

This feature allows you to cook food with microwave and steam at the same time. This generally means food keep its moisture by help of added steam. This feature is suitable for food such as vegetable, rice and meals. Using this mode without covering food. Before cooking, fill the water vessel with purified water up to Max.

## POWER

<b>HIGH</b>	700 W
<b>MEDIUM HIGH</b>	450 W
<b>MEDIUM</b>	300 W
<b>DEFROST MEDIUM LOW</b>	180 W
<b>LOW</b>	90 W

\* Refer to next page for Accessory

Make sure that you have correctly installed your oven as described earlier in this book.

Press **STOP/CLEAR**.

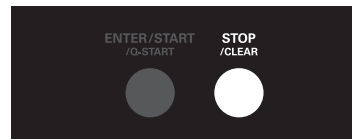

Turn **FUNCTION selection dial** to select **Microwave**.

The following indication is displayed: "≡"

Press **STEAM+/CLOCK**.

The following indication is displayed: "☁"



Turn **CONTROL dial** until display shows "450W".

Press **ENTER/START/Q-START** for power confirmation.

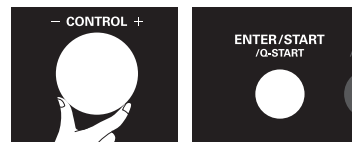

Turn **CONTROL dial** until display shows "5:00".

Press **ENTER/START/Q-START**.

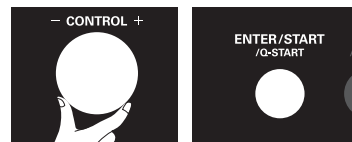

## Cooking Guide

This table shows recommended settings and time for Micro Power Steam+ Cooking. The times are only a guide.

Allow for difference in individual tastes and preferences. The times may also vary due to the shape, cut, and composition of the food.

<i>Food</i>	<i>Amount</i>	<i>Utensil</i>	<i>Level</i>	<i>Cook mode</i>	<i>Cook time (minutes)</i>
Chicken Pieces	4 pieces	Rack on the oven bottom	Bottom	Steam+ 300W	12~16
Reheat Lasagna	2-4 servings	Heatproof glass dish on the Rack on the oven bottom	Bottom	Steam+ 300W	8~12
Reheat Plated Meal	1 serving	Heatproof glass dish on the Rack on the oven bottom	Bottom	Steam+ 300W	5~8
Rice / Risotto	1 cup	Heatproof glass dish on the Rack on the oven bottom	Bottom	Steam+ 300W	18~22
Frozen Vegetables	0.5 kg	Heatproof glass dish on the Rack on the oven bottom	Bottom	Steam+ 700W	10~13
Jacket Potatoes	4ea. med	Rack on the oven bottom	Bottom	Steam+ 700W	13~15
Pudding	0.3 kg	Heatproof glass dish on the Rack on the oven bottom	Bottom	Steam+ 180W	20~30

**Rack**

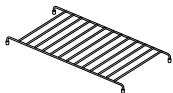

**\* Rack Location**

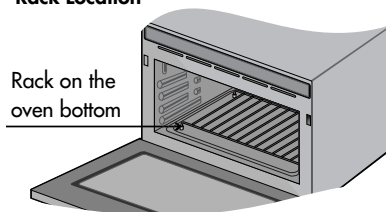

# Convection Steam+ Cooking

In the following example I will show you how to use the Convection Steam+ Cooking mode to cook some foods for 50 minutes at 230°C temperature.

If you do not set a temperature your oven will automatically select 180°C, the cooking temperature can be changed by turning **CONTROL dial**.

This feature allows you to cook food with convection and steam at the same time. Use this feature to cook food that need to retain moisture and have a crisp brown exterior. This feature is suitable for baking cake/bread and roasting meat/poultry. Before cooking, fill the water vessel with purified water up to Max.

**The Metal tray must be used during Convection Steam+ cooking.**

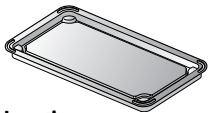

\* Tray Location

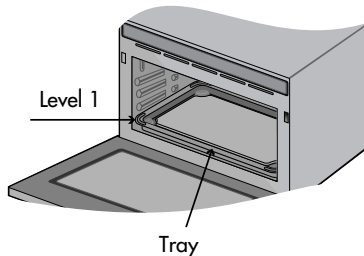

Press **STOP/CLEAR**.

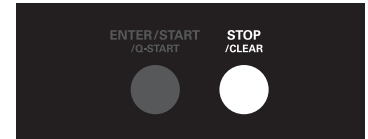

Turn **FUNCTION selection dial** to select **Conv.**

The following indication is displayed: "🌀"

Press **STEAM+/CLOCK**.

The following indication is displayed: "🌀"



Turn **CONTROL dial** until display shows "230°C".

Press **ENTER/START/Q-START** for temperature confirmation.

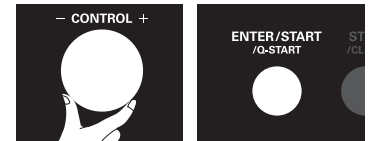

Turn **CONTROL dial** until display shows "50:00".



Press **ENTER/START/Q-START**.

When cooking you can increase or decrease cooking time by turning **CONTROL dial**.

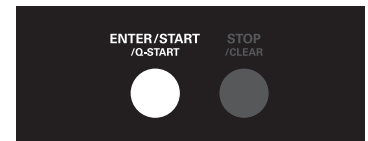



## ***Cooking Guide***

This table shows recommended settings and time for Convection Steam+ Cooking. The times are only a guide.

Allow for difference in individual tastes and preferences. The times may also vary due to the shape, cut, and composition of the food.

<b><i>Food</i></b>	<b><i>Utensil</i></b>	<b><i>Level</i></b>	<b><i>Cook mode</i></b>	<b><i>Cook time (minutes)</i></b>
Homemade Pizza	Metal tray	2	Steam+ Convection 180°C	15~20
Cookies	Metal tray	2	Steam+ Convection 170°C	15~20
Chocolate Cake	20 cm Cake pan on the Rack on the Metal tray	1	Steam+ Convection 170°C	30~40
Gratin Dauphinois	Gratin dish on the Rack on the Metal tray	1	Steam+ Convection 180°C	30~40
Lasagna	26 x 17 cm baking dish on the Rack on the Metal tray	2	Steam+ Convection 180°C	30~40
Roast Chicken 1.5 kg	Rack on the Metal tray	1	Steam+ Convection 200°C	60~80
Roast Pork 1 kg	Rack on the Metal tray	1	Steam+ Convection 180°C	100~140

# Steam+

In the following example I will show you how to use the Steam+ mode to cook some foods for 25 minutes.



This feature allows you to steam food such as vegetables, seafood, fish and eggs. Before cooking, fill the water vessel with purified water up to Max.

**The Metal tray must be used during Steam+ cooking.**

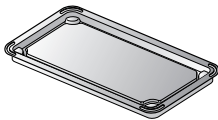

\* Tray Location

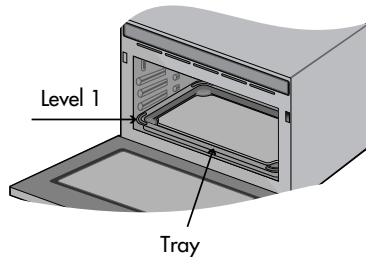

Press **STOP/CLEAR**.

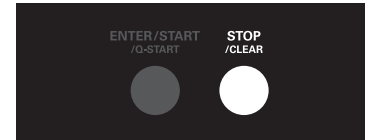

Press **STEAM+/CLOCK**.

The following indication is displayed: "👏"

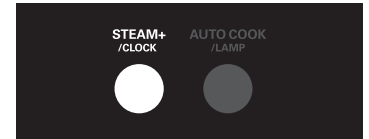

Turn **CONTROL dial** until display shows "25:00".

Press **ENTER/START/Q-START**.

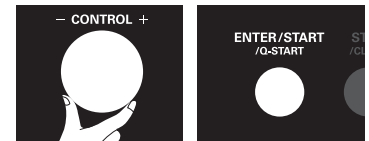

**After cooking you must wear heat proof oven gloves to take metal tray out of the oven as the tray and its contents will be very hot.**

## Cooking Guide

This table shows recommended time for Steam+. The times are only a guide. Allow for difference in individual tastes and preferences.

The times may also vary due to the shape, cut, and composition of the food.

<i>Food</i>	<i>Amount</i>	<i>Utensil</i>	<i>Level</i>	<i>Cook time (minutes)</i>	<i>Instructions</i>
Mussel	1 kg	Metal tray	1	10~12	Clean the mussels, discarding any broken shell or dead mussels. Add 1 cup of dry white wine. After steaming, drain and reserve mussel liquor and reduce it to 3/4 cup. Remove top shell of mussels. Add butter and pepper to broth and pour over mussels.
Prawn	0.5 kg	Rack on the Metal tray	1	9~11	Clean the prawn with shell in salted water.
Whole Fish	0.5 kg	Rack on the Metal tray	1	25~30	Prepare fresh fish
Fish Fillet	0.5 kg	Metal tray	1	10~15	Season as desired.
Sausage	0.5 kg	Rack on the Metal tray	1	22~25	Slit the skin of sausage.
Ham	0.5 kg	Metal tray	1	13~16	Slice ham.
Chicken Breast	4 pieces	Rack on the Metal tray	1	16~18	Season as desired.
Eggs	8ea.	Rack on the Metal tray	1	17~19	Place on the rack on the Metal tray
Broccoli, Florets	0.3 kg	Metal tray	1	12~14	Clean and cut into floret.
Spinach	0.3 kg	Metal tray	1	7~9	Clean
Eggplant	3-4ea.	Metal tray	1	12~14	Clean and cut in half length ways.
Tomato	0.5 kg	Metal tray	1	12~15	Clean and cut into small pieces.
Apple	3-4ea.	Metal tray	1	12~15	Peel and core. Cut into slice or cube.
Potato	3-4ea.	Metal tray	1	40~50	Peel and cut into small pieces.

# Auto Cooking

In the following example I will show you how to cook 0.4kg of Lamb filet mignon.



Auto Cooking menus are programmed. Auto Cooking allows you to cook most of your favorite food by selecting the food type and the weight of the food.

Press **STOP/CLEAR**.



Press **AUTO COOK/LAMP**.

The following indication is displayed: "Auto"

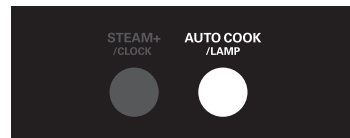

Turn **CONTROL dial** until display shows "Ac 3".

Press **ENTER/START/Q-START** for category confirmation.

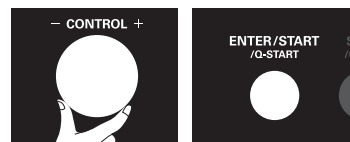

Turn **CONTROL dial** until display shows "0.4kg".

Press **ENTER/START/Q-START**.

**After cooking you must wear heat proof oven gloves to take metal tray out of the oven as the tray and its contents will be very hot.**

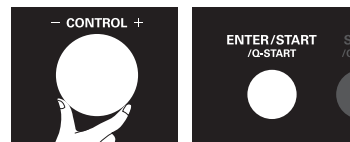

<i>Function</i>	<i>Category</i>		<i>Weight Limit</i>	<i>Utensil</i>	<i>Level</i>	<i>Food Temp.</i>	<i>Instructions</i>
<b>Auto Cook</b>	Ac 1	Frozen Pizza	0.3–0.6kg	Rack on the Metal tray	1	Frozen	Remove Pizza from package and place food on the Rack on the Metal tray. Choose the menu and weight, press start.
	Ac 2	French Fries	0.2–0.4kg	Metal tray	1	Frozen	Spread frozen potato products out on the greased Metal tray. For the best results, cook in a single layer. Choose the menu and weight, press start.
	Ac 3	Lamb Filet Mignon	0.3–0.6kg	Rack on the Metal tray	3	Refrigerated	Choose Lamb filet mignon of 2.5cm thickness each. Season with salt and pepper or as desired. Place food on the Rack on the Metal tray. Choose the menu and weight, press start. When BEEP, turn food over and press start to continue cooking.
	Ac 4	Jacket Potatoes	0.2–1.0kg	Rack on the Metal tray	1	Room	Choose medium sized potatoes. (200-220g per each) Wash and dry potatoes. Pierce potatoes several times with a fork. Place food on the Rack on the Metal tray. Choose the menu and weight, press start. After cooking, remove food from the oven. Let stand covered with foil for 5 minutes.
	Ac 5	Frozen Dinners	0.3–0.6kg	Rack on the Metal tray	1	Frozen	Remove tray from box packages and cut film cover to vent. Place food on the Rack on the Metal tray. Choose the menu and weight, press start.

Function	Category		Weight Limit	Utensil	Level	Food Temp.	Instructions																
Auto Cook	Ac 6	Rice/ Pasta	0.1–0.3kg	Microwave-safe bowl (deep glass pot) on the Rack on the Metal tray	1	Room	<p>Place rice/pasta and boiling water with <math>\frac{1}{4}</math> to 1 teaspoon salt in a deep and large bowl(3 ℓ ). Place bowl on the Rack on the Metal tray. Choose the menu and weight, press start. When BEEP, stir and press start to continue cooking.</p> <table border="1"> <tr> <td>Weight</td> <td>100g</td> <td>200g</td> <td>300g</td> <td>Cover</td> </tr> <tr> <td rowspan="2">Water</td> <td>Rice</td> <td>250ml</td> <td>500ml</td> <td>750ml</td> <td>Cover and vent with wrap</td> </tr> <tr> <td>Pasta</td> <td>400ml</td> <td>800ml</td> <td>1200ml</td> <td>Uncover</td> </tr> </table> <p>** Rice - After cooking, stand covered for 5 minutes or until water is absorbed.</p> <p>** Pasta – After cooking, stand for 1-2 minutes. Rinse pasta with cold water.</p>	Weight	100g	200g	300g	Cover	Water	Rice	250ml	500ml	750ml	Cover and vent with wrap	Pasta	400ml	800ml	1200ml	Uncover
	Weight	100g	200g	300g	Cover																		
Water	Rice	250ml	500ml	750ml	Cover and vent with wrap																		
	Pasta	400ml	800ml	1200ml	Uncover																		
	Ac 7	Quiche Lorraine	0.8kg	20cm Pie pan on the Metal tray	2	Room	<p><b>Ingredients</b></p> <table border="0"> <tr> <td><b>For Filling :</b></td> <td><b>For Pastry :</b></td> </tr> <tr> <td>1 medium onion(150g), chopped and cooked</td> <td>1 sheet of pastry</td> </tr> <tr> <td>3 bacon rashers, chopped and cooked</td> <td></td> </tr> <tr> <td>3 eggs</td> <td></td> </tr> <tr> <td>300ml cream</td> <td></td> </tr> <tr> <td><math>\frac{1}{2}</math> cup milk</td> <td></td> </tr> <tr> <td><math>\frac{3}{4}</math> cup grated mozzarella cheese</td> <td></td> </tr> </table> <ol style="list-style-type: none"> <li>Combine the ingredients of filling and set aside.</li> <li>On a lightly floured surface, roll out pastry into a circle and line a quiche pan. Trim edges, leaving a little overhang and prick with a fork.</li> <li>Line with baking paper and fill with dried beans or pie weights. Place pie pan on the Metal tray. Choose the menu and weight, press start.</li> <li>When BEEP, remove paper and beans carefully. And then press start to continue cooking.</li> <li>On the second BEEP, take food out from the oven and pour the filling into the baked pastry. Press start to continue cooking.</li> </ol>	<b>For Filling :</b>	<b>For Pastry :</b>	1 medium onion(150g), chopped and cooked	1 sheet of pastry	3 bacon rashers, chopped and cooked		3 eggs		300ml cream		$\frac{1}{2}$ cup milk		$\frac{3}{4}$ cup grated mozzarella cheese			
<b>For Filling :</b>	<b>For Pastry :</b>																						
1 medium onion(150g), chopped and cooked	1 sheet of pastry																						
3 bacon rashers, chopped and cooked																							
3 eggs																							
300ml cream																							
$\frac{1}{2}$ cup milk																							
$\frac{3}{4}$ cup grated mozzarella cheese																							

<i>Function</i>	<i>Category</i>		<i>Weight Limit</i>	<i>Utensil</i>	<i>Level</i>	<i>Food Temp.</i>	<i>Instructions</i>
Auto Cook	Ac 8	Sole Filet	0.2–0.8kg	Rack on the Metal tray	3	Refrigerated	Choose sole fillet of 200g weight and 2.5cm thickness each. Season with salt and pepper or as desired. Place food on the Rack on the Metal tray. Choose the menu and weight, press start. When BEEP, stir and press start to continue cooking.
	Ac 9	Egg Casserole	1–4 servings	Ramekin on the Metal tray	1	Refrigerated	<div style="border: 1px solid black; padding: 5px;"> <p><b>Ingredients for 1 serving</b></p> <p>2 eggs</p> <p>2 tablespoons cream</p> <p>40g grated mozzarella cheese</p> </div> <p>Add eggs in a small ramekin without breaking egg yolks. Spread cream and cheese on top. Place ramekin on the Metal tray. Choose the menu and weight, press start.</p>
	Ac 10	Gratin of Zucchini	1	26x17cm Baking dish on the Metal tray	1	Room	<div style="border: 1px solid black; padding: 5px;"> <p><b>Ingredients</b></p> <p>4 big zucchinis or 6 small ones</p> <p>100ml white wine</p> <p>120g grated parmesan cheese</p> <p>Salt and pepper to taste</p> </div> <p>Wash and cut zucchinis in thin slices. Line them up in a baking dish. Pour white wine and spread parmesan cheese on top. Place baking dish on the Metal tray. Choose the menu and weight, press start.</p>

Function	Category		Weight Limit	Utensil	Level	Food Temp.	Instructions																				
Auto Cook	Ac 11	Cinnamon Apple and Pear Ravioli	0.1–0.4kg	Microwave-safe bowl (deep glass pot) on the Rack on the Metal tray	1	Refrigerated	<table border="1"> <tr> <td>Weight of ravioli</td> <td>100g</td> <td>200g</td> <td>300g</td> <td>400g</td> </tr> <tr> <td>Boiling Water</td> <td>250ml</td> <td>500ml</td> <td>750ml</td> <td>1000ml</td> </tr> </table> <p>Place ravioli and boiling water with 1/4 to 1 teaspoon salt in a deep and large bowl. Place bowl on the Rack on the Metal tray. Choose the menu and weight, press start. After cooking, stand for 1-2 minutes. Drain remaining water and combine with the garnish. Finally sprinkle top with parmesan cheese and serve.</p> <table border="1"> <tr> <td colspan="2"><b>For garnish :</b></td> </tr> <tr> <td>2 tablespoons olive oil</td> <td>1/2 cup fresh flat-leaf parsley, chopped</td> </tr> <tr> <td>1/2 cup walnuts, roughly chopped, toasted</td> <td>1 teaspoon cinnamon</td> </tr> <tr> <td>1 apple, cut into matchsticks</td> <td>Salt and pepper to taste</td> </tr> <tr> <td>1 pear, cut into matchsticks</td> <td>20g grated parmesan cheese</td> </tr> </table>	Weight of ravioli	100g	200g	300g	400g	Boiling Water	250ml	500ml	750ml	1000ml	<b>For garnish :</b>		2 tablespoons olive oil	1/2 cup fresh flat-leaf parsley, chopped	1/2 cup walnuts, roughly chopped, toasted	1 teaspoon cinnamon	1 apple, cut into matchsticks	Salt and pepper to taste	1 pear, cut into matchsticks	20g grated parmesan cheese
	Weight of ravioli	100g	200g	300g	400g																						
Boiling Water	250ml	500ml	750ml	1000ml																							
<b>For garnish :</b>																											
2 tablespoons olive oil	1/2 cup fresh flat-leaf parsley, chopped																										
1/2 cup walnuts, roughly chopped, toasted	1 teaspoon cinnamon																										
1 apple, cut into matchsticks	Salt and pepper to taste																										
1 pear, cut into matchsticks	20g grated parmesan cheese																										
Ac 12	Potato Soufflé with Parmesan	1	22cm Soufflé dish on the Metal tray	1	Room	<table border="1"> <tr> <td colspan="2"><b>Ingredients</b></td> </tr> <tr> <td>8 servings instant mashed potatoes, made according to package directions</td> <td>1 cup grated parmesan cheese</td> </tr> <tr> <td>6 eggs, separated</td> <td>1 teaspoon salt</td> </tr> <tr> <td></td> <td>1 teaspoon cream</td> </tr> </table> <ol style="list-style-type: none"> <li>1. Prepare instant mashed potatoes according to package directions for 8 servings and cool.</li> <li>2. Combine egg yolks, parmesan cheese and mashed potatoes.</li> <li>3. In a separate bowl, beat egg whites to have firm peaks. Continue beating egg whites, while slowly adding salt and cream.</li> <li>4. Fold beaten whites into potato mixture. Spoon into a greased soufflé dish.</li> <li>5. Place soufflé dish on the Metal tray. Choose the menu and weight, press start.</li> </ol>	<b>Ingredients</b>		8 servings instant mashed potatoes, made according to package directions	1 cup grated parmesan cheese	6 eggs, separated	1 teaspoon salt		1 teaspoon cream													
<b>Ingredients</b>																											
8 servings instant mashed potatoes, made according to package directions	1 cup grated parmesan cheese																										
6 eggs, separated	1 teaspoon salt																										
	1 teaspoon cream																										



Function	Category		Weight Limit	Utensil	Level	Food Temp.	Instructions
Auto Cook	Ac 13	Rabbit	0.3–1.0kg	Rack on the Metal tray	3	Refrigerated	Brush rabbit with melted butter or oil and season as desired. Place food on the Rack on the Metal tray. Choose the menu and weight, press start. When BEEP, stir and press start to continue cooking.
	Ac 14	Chicken Pieces	0.2–0.8kg	Rack on the Metal tray	3	Refrigerated	Brush chicken pieces with melted butter or oil and season as desired. Place food on the Rack on the Metal tray. Choose the menu and weight, press start. When BEEP, stir and press start to continue cooking.
	Ac 15	Sausage	0.2–0.6kg	Rack on the Metal tray	3	Refrigerated	Remove Sausage from packaging and slit on surface. Place food on the Rack on the Metal tray. Choose the menu and weight, press start. When BEEP, turn food over and press start to cooking.
	Ac 16	Cake with Candied Fruits	0.9kg	23x13cm Loaf pan on the Metal tray	1	Room	<div style="border: 1px solid black; padding: 5px;"> <p><b>Ingredients</b></p> <ul style="list-style-type: none"> <li>120g raisins</li> <li>150g sugar</li> <li>3 eggs, lightly beaten</li> <li>250g flour</li> <li>150g butter, softened</li> <li>3g lemon peel</li> <li>5g baking powder</li> <li>20g lemon juice</li> <li>20g rum</li> <li>180g candied fruits</li> </ul> </div> <p>Place dry raisins in hot water to inflate and drain. Combine all ingredients and pour batter into a greased loaf pan. Place loaf pan on the Metal tray. Choose the menu and weight, press start.</p>

<i>Function</i>	<i>Category</i>		<i>Weight Limit</i>	<i>Utensil</i>	<i>Level</i>	<i>Food Temp.</i>	<i>Instructions</i>
Auto Cook	Ac 17	Apple Pie	1	22cm Tart pan on the Metal tray	2	Room	<div style="border: 1px solid black; padding: 5px;"> <p><b>Ingredients</b>  1 sheet of pastry  100g apple jam  2 apples, cut into 5mm thickness</p> </div> <p>On a lightly floured surface, roll out pastry into a circle and line a tart pan.  Prick with a fork.  Spread jam and sliced apples on the pastry.  Place tart pan on the Metal tray.  Choose the menu and weight, press start.</p>
	Ac 18	Chocolate cake	0.7kg	20cm Cake pan on the Metal tray	1	Room	<div style="border: 1px solid black; padding: 5px;"> <p><b>Ingredients</b>  120g butter, softened  200g sugar  3 eggs, lightly beaten  170g chocolate, chopped  80g flour  1 teaspoon coffee</p> </div> <p>Beat softened butter with sugar and add eggs.  Melt chopped chocolate, then combine all ingredients well.  Pour batter into a greased cake pan.  Place cake pan on the Metal tray.  Choose the menu and weight, press start.</p>

<i>Function</i>	<i>Category</i>		<i>Weight Limit</i>	<i>Utensil</i>	<i>Level</i>	<i>Food Temp.</i>	<i>Instructions</i>
Auto Cook	Ac 19	Floating Island	1	Microwave-safe dish on the Rack on the Metal tray	1	Room	<div style="border: 1px solid black; padding: 5px;"> <p><b>Ingredients</b></p> <p><b>For Meringues :</b>  3 egg whites  40g sugar</p> <p><b>For Custard :</b>  1/2 cup of hot milk  3 egg yolks  70g sugar</p> </div> <ol style="list-style-type: none"> <li>1. Beat egg whites to have firm peaks. Continue beating egg whites, while slowly adding sugar.</li> <li>2. Combine the ingredients of custard in a separate bowl and set aside.</li> <li>3. Put large spoonfuls of meringues in a microwave-safe dish on the Rack on the Metal tray. Choose the menu and weight, press start.</li> <li>4. When BEEP, remove from the oven and pour the custard mixture on the top of meringues. And then press start to continue cooking.</li> </ol>

Function	Category		Weight Limit	Utensil	Level	Food Temp.	Instructions
Auto Cook	Ac 20	Tomato-Mozzarella-Basil Cake	0.8kg	23x13cm Loaf pan on the Metal tray	1	Room	<p><b>Ingredients</b></p> <p>5 eggs, lightly beaten  1/2 cup milk  1 tablespoon olive oil  200g grated mozzarella cheese  50g grated parmesan cheese  2 tablespoons tomato paste  2 tablespoons basil  250g flour  5g baking powder  Salt and pepper to taste</p> <p>1. Combine eggs, milk, olive oil, mozzarella and parmesan cheese, tomato paste and basil.  2. In a separate bowl, mix remaining ingredients, then combine both mixtures together.  3. Pour batter into a greased loaf pan. Place loaf pan on the Metal tray. Choose the menu and weight, press start.</p>

< Metal Tray >

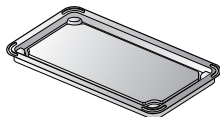

< Rack >

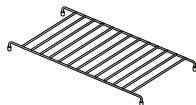

< Rack + Metal Tray >

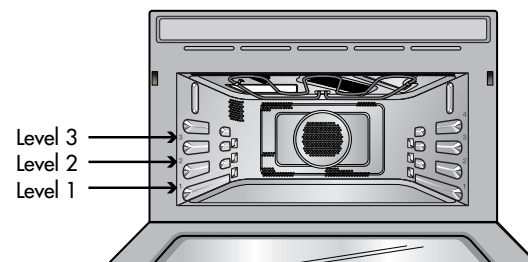
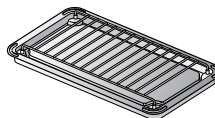

# Steam+ Auto Cooking

In the following example I will show you how to cook 0.3kg of Broccoli.



Steam+ Auto Cooking menus are programmed.  
Steam+ Auto Cooking allows you to cook most of your favorite food by selecting the food type and the weight of the food.

## CAUTION

After finishing steam cooking, please use Drain water Function, because there is possibility some water remains in the steam generator.  
(Refer to 54p for more information about **Drain water Function**)

Press **STOP/CLEAR**.

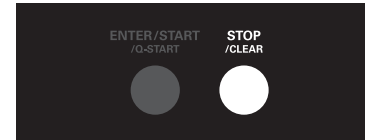

Press **AUTO COOK/LAMP**.

The following indication is displayed: "  "

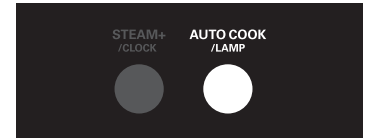

Press **STEAM+/CLOCK**.

The following indication is displayed: "  "

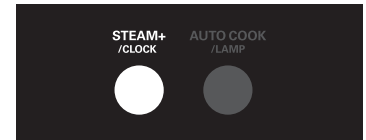

Turn **CONTROL dial** until display shows "St 5".



Press **ENTER/START/Q-START** for category confirmation.

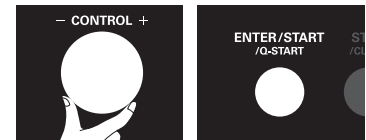

Turn **CONTROL dial** until display shows "0.3kg".

Press **ENTER/START/Q-START**.

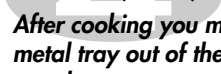

**After cooking you must wear heat proof oven gloves to take metal tray out of the oven as the tray and its contents will be very hot.**

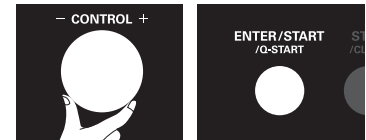

<b>Function</b>	<b>Category</b>		<b>Weight Limit</b>	<b>Utensil</b>	<b>Level</b>	<b>Food Temp.</b>	<b>Instructions</b>
<b>Steam+ Auto Cooking</b>	St 1	Fish fillet	0.2–0.6kg	Microwave-safe dish on the Rack on the Metal tray	1	Refrigerated	Fill water vessel with purified water up to Max. Place food in a microwave - safe dish on the Rack on the Metal tray. Choose the menu and weight, press start.
	St 2	Crustacea	0.2–0.5kg	Microwave-safe dish on the Rack on the Metal tray	1	Refrigerated	Fill water vessel with purified water up to Max. Choose food under 20cm length. Place food in a microwave - safe dish on the Rack on the Metal tray. Choose the menu and weight, press start.
	St 3	Shellfish	0.5–1.0kg	Metal tray	1	Refrigerated	Fill water vessel with purified water up to Max. Place food on the Metal tray. Choose the menu and weight, press start.
	St 4	Carrots	0.2–0.6kg	Microwave-safe bowl on the Rack on the Metal tray	1	Room	Fill water vessel with purified water up to Max. Slice carrots into 5mm thickness. Place food in a microwave - safe bowl on the Rack on the Metal tray. Choose the menu and weight, press start.
	St 5	Broccoli	0.2–0.4kg	Microwave-safe dish on the Rack on the Metal tray	1	Room	Fill water vessel with purified water up to Max. Cut broccoli into small florets. (12g-15g/piece) Place food in a microwave - safe dish on the Rack on the Metal tray. Choose the menu and weight, press start.
	St 6	Spinach	0.3–0.5kg	Metal tray	1	Refrigerated	Fill water vessel with purified water up to Max. Place food on the Metal tray. Choose the menu and weight, press start.
	St 7	Cauliflower	0.2–0.4kg	Microwave-safe dish on the Rack on the Metal tray	1	Room	Fill water vessel with purified water up to Max. Cut cauliflower into small florets. (12g-15g/piece) Place food in a microwave - safe dish on the Rack on the Metal tray. Choose the menu and weight, press start.

<i>Function</i>	<i>Category</i>		<i>Weight Limit</i>	<i>Utensil</i>	<i>Level</i>	<i>Food Temp.</i>	<i>Instructions</i>
<b>Steam+ Auto Cooking</b>	St 8	Potatoes	0.2–1.0kg	Microwave-safe dish on the Rack on the Metal tray	1	Room	Fill water vessel with purified water up to Max. Choose medium sized potatoes. (200-220g per each) Wash and dry potatoes. Pierce potatoes several times with a fork. Place food in a microwave - safe dish on the Rack on the Metal tray. Choose the menu and weight, press start.
	St 9	French beans	0.1–0.3kg	Microwave-safe dish on the Rack on the Metal tray	1	Room	Fill water vessel with purified water up to Max. Place food in a microwave - safe dish on the Rack on the Metal tray. Choose the menu and weight, press start.
	St 10	Artichoke	0.1–0.3kg	Microwave-safe dish on the Rack on the Metal tray	1	Room	Fill water vessel with purified water up to Max. Take leaves off and spread in a single layer on a microwave-safe dish. Place food on the Rack on the Metal tray. Choose the menu and weight, press start.
	St 11	Guinea fowl	0.8–1.5kg	Rack on the Metal tray	1	Refrigerated	Fill water vessel with purified water up to Max. Place food on the Rack on the Metal tray. Choose the menu and weight, press start.
	St 12	Aubergine	0.2–0.4kg	Microwave-safe dish on the Rack on the Metal tray	1	Room	Fill water vessel with purified water up to Max. Cut aubergine into 2.5cm thickness. Place food in a microwave - safe dish on the Rack on the Metal tray. Choose the menu and weight, press start.
	St 13	Asparagus	0.2–0.4kg	Microwave-safe dish on the Rack on the Metal tray	1	Room	Fill water vessel with purified water up to Max. Place food in a microwave - safe dish on the Rack on the Metal tray. Choose the menu and weight, press start.
	St 14	Frozen Vegetables	0.2–0.6kg	Microwave-safe bowl on the Rack on the Metal tray	1	Frozen	Fill water vessel with purified water up to Max. Place food in a microwave - safe bowl on the Rack on the Metal tray. Choose the menu and weight, press start.

<b>Function</b>	<b>Category</b>		<b>Weight Limit</b>	<b>Utensil</b>	<b>Level</b>	<b>Food Temp.</b>	<b>Instructions</b>
<b>Steam+ Auto Cooking</b>	St 15	Boiled Eggs	5–10 eggs	Rack on the Metal tray	1	Refrigerated	Fill water vessel with purified water up to Max. Place food on the Rack on the Metal tray. Choose the menu and weight, press start.
	St 16	Whole Chicken	1.3–1.6kg	Rack on the Metal tray	1	Refrigerated	Fill water vessel with purified water up to Max. Brush whole chicken with melted butter or oil and season as desired. Place whole chicken breast-side down on the Rack. Choose the menu and weight, press start. When BEEP, turn food over and press start to continue cooking. After cooking, let stand covered with foil for 10 minutes.
	St 17	Leg of lamb	0.5–1.5kg	Rack on the Metal tray	1	Refrigerated	Fill water vessel with purified water up to Max. Brush leg of lamb with melted butter or oil and season as desired. Place food on the Rack on the Metal tray. Choose the menu and weight, press start. When BEEP, turn food over and press start to continue cooking. After cooking, stand covered with foil for 10 minutes.
	St 18	Pork joint	0.5–1.5kg	Rack on the Metal tray	1	Refrigerated	Fill water vessel with purified water up to Max. Trim excess fat from pork. Brush pork with melted butter or oil and season as desired. Place food on the Rack on the Metal tray. Choose the menu and weight, press start. When BEEP, turn food over and press start to continue cooking. After cooking, stand covered with foil for 10 minutes.
	St 19	Beef joint	0.5–1.5kg	Rack on the Metal tray	1	Refrigerated	Fill water vessel with purified water up to Max. Brush beef with melted butter or oil and season as desired. Place food on the Rack on the Metal tray. Choose the menu and weight, press start. When BEEP, turn food over and press start to continue cooking. After cooking, stand covered with foil for 10 minutes.



<i>Function</i>	<i>Category</i>		<i>Weight Limit</i>	<i>Utensil</i>	<i>Level</i>	<i>Food Temp.</i>	<i>Instructions</i>
<b>Steam+ Auto Cooking</b>	St 20	Cream Caramel	1.2kg	22cm Baking dish on the Metal tray	2	Refrigerated	<div style="border: 1px solid black; padding: 5px;"> <p><b>Ingredients</b>  <b>For Caramel :</b>  200g sugar  50ml water</p> <p><b>For Custard :</b>  750ml milk  125g sugar  6 eggs</p> </div> <p>1. Fill water vessel with purified water up to Max.  2. Combine the ingredients of caramel in a skillet and cook until melted and golden brown over a low heat with a cook top.  3. Pour this caramel into a baking dish, turning around quickly to coat bottom and sides and cool.  4. Combine the ingredients of custard and pour into caramel.  5. Place baking dish on the Metal tray.  Choose the menu and weight, press start.  After cooking, stand for 4~5 hours in a refrigerator and turn food over onto serving dish.</p>

# Defrost

**\* When defrosting, use only rack.**



Your oven has four microwave defrost settings:- **Meat, Poultry, Fish** and **Bread**; each defrost category has different power settings. Repeated presses of the **Defrost** button will select a different setting.

## \* Rack Location

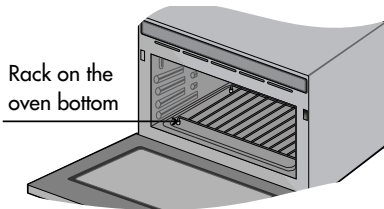

The temperature and density of food varies, I would recommend that the food be checked before cooking commences. Pay particular attention to large joints of meat and chicken, some foods should not be completely thawed before cooking. For example fish cooks so quickly that it is sometimes better to begin cooking while still slightly frozen. The bread programme is suitable for defrosting small items such as rolls or a small loaf. These will require a standing time to allow the centre to thaw. In the following example I will show you how to defrost 0.8Kg of frozen poultry.

Press **STOP/CLEAR**.

Weigh the food that you are about to defrost. Be certain to remove any metallic ties or wraps; then place the food on microwave safe dish on Metal tray in your oven and close the oven door.

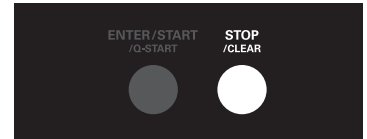

Turn **FUNCTION** selection dial to select **Defrost**.

The following indication is displayed: "δδ"



Turn **CONTROL** dial until display shows "dEF2".

Press **ENTER/START/Q-START** for category confirmation.

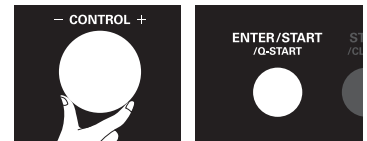

Enter the weight of the frozen food that you are about to defrost.

Turn **CONTROL** dial until display shows "0.8kg" for the weight of frozen food.

Press **ENTER/START/Q-START**.



During defrosting your oven will "BEEP", at which point open the oven door, turn food over and separate to ensure even thawing. Remove any portions that have thawed or shield them to help slow down thawing. After checking, close the oven door and press **ENTER/START/Q-START** to resume defrosting.

**Your oven will not stop defrosting (even when the beep sounded) unless the door is opened.**

## Defrosting Guide

- \* Food to be defrosted should be in a suitable microwave proof container and place uncovered on the rack.
  - \* If necessary, shield small areas of meat or poultry with flat pieces of aluminum foil. This will prevent thin areas becoming warm during defrosting. Ensure the foil does not touch the oven walls.
  - \* Separate items like minced meat, chops, sausages and bacon as soon as possible.
- When BEEP, turn food over.** Remove defrosted portions. Continue to defrost remaining pieces.  
After defrosting, allow to stand until completely thawed.

Category	Weight Limit	Utensil	Level	Food
<b>Meat (dEF1)</b>	0.1 – 2.0 kg	Rack	Bottom	<b>Meat</b> Minced beef, Fillet steak, Cubes for stew, Sirloin steak, Pot roast, Rump roast, Beef burger Pork chops, Lamb chops, Rolled roast, Sausage, Cutlets(2cm) Turn food over at beep. After defrosting, let stand for 5-15 minutes.
<b>Poultry (dEF2)</b>	0.1 – 2.0 kg			<b>Poultry</b> Whole chicken, Legs, Breasts, Turkey breasts. Turn food over at beep. After defrosting, let stand for 20-30 minutes.
<b>Fish (dEF3)</b>	0.1 – 2.0 kg			<b>Fish</b> Fillets, Steaks, Whole fish, Sea foods Turn food over at beep. After defrosting, let stand for 10-20 minutes.
<b>Bread (dEF4)</b>	0.1 – 0.5 kg			Rack + Paper towel

# Defrost Steam+

**\* When defrosting, use only rack.**



Your oven has four microwave defrost settings:- **Meat, Poultry, Fish** and **Bread**; each defrost category has different power settings.

Repeated presses of the **Defrost** button will select a different setting.

After using steam defrost, Make sure to operate **multi clean (Drain Water)** function.

## \* Rack Location

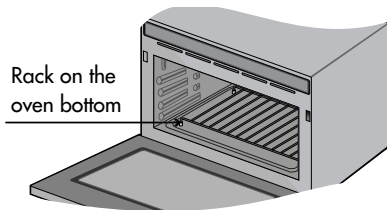

The temperature and density of food varies, I would recommend that the food be checked before cooking commences. Pay particular attention to large joints of meat and chicken, some foods should not be completely thawed before cooking. For example fish cooks so quickly that it is sometimes better to begin cooking while still slightly frozen. The bread programme is suitable for defrosting small items such as rolls or a small loaf. These will require a standing time to allow the centre to thaw. In the following example I will show you how to defrost 0.8Kg of frozen poultry.

Press **STOP/CLEAR**.

Weigh the food that you are about to defrost. Be certain to remove any metallic ties or wraps; then place the food on microwave safe dish on Metal tray in your oven and close the oven door.



Turn **FUNCTION** selection dial to select **Defrost**.

The following indication is displayed: " \*\* "

Press **STEAM+ /CLOCK**.

The following indication is displayed: " 🍗 "



Turn **CONTROL** dial until display shows "DEF2".

Press **ENTER/START/Q-START** for category confirmation.

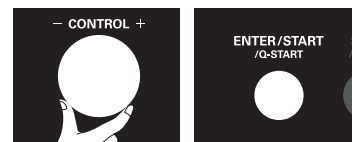

Enter the weight of the frozen food that you are about to defrost.

Turn **CONTROL** dial until display shows "0.8kg" for the weight of frozen food.

Press **ENTER/START/Q-START**.

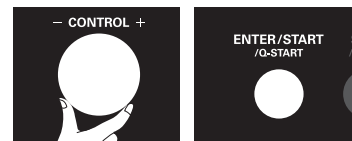

During defrosting your oven will "BEEP", at which point open the oven door, turn food over and separate to ensure even thawing. Remove any portions that have thawed or shield them to help slow down thawing. After checking, close the oven door and press **ENTER/START/Q-START** to resume defrosting.

**Your oven will not stop defrosting (even when the beep sounded) unless the door is opened.**

## Defrost Steam+ Guide

- \* Food to be defrosted should be in a suitable microwave proof container and place uncovered on the rack.
- \* If necessary, shield small areas of meat or poultry with flat pieces of aluminum foil. This will prevent thin areas becoming warm during defrosting. Ensure the foil does not touch the oven walls.
- \* Separate items like minced meat, chops, sausages and bacon as soon as possible.  
**When BEEP, turn food over.** Remove defrosted portions. Continue to defrost remaining pieces.  
 After defrosting, allow to stand until completely thawed.
- \* Before Steam defrost, Clean up the water vessel and fill it with water by MAX.
- \* After Steam defrost, Use steam multi-clean No."2" (Drain Water)

Category	Weight Limit	Utensil	Level	Food
<b>Meat</b> (DEF1)	0.1 – 2.0 kg	Rack	Bottom	<b>Meat</b> Minced beef, Fillet steak, Cubes for stew, Sirloin steak, Pot roast, Rump roast, Beef burger Pork chops, Lamb chops, Rolled roast, Sausage, Cutlets(2cm) Turn food over at beep. After defrosting, let stand for 5-15 minutes.
<b>Poultry</b> (DEF2)	0.1 – 2.0 kg			<b>Poultry</b> Whole chicken, Legs, Breasts, Turkey breasts. Turn food over at beep. After defrosting, let stand for 20-30 minutes.
<b>Fish</b> (DEF3)	0.1 – 2.0 kg			<b>Fish</b> Fillets, Steaks, Whole fish, Sea foods Turn food over at beep. After defrosting, let stand for 10-20 minutes.
<b>Bread</b> (DEF4)	0.1 – 0.5 kg			Rack + Paper towel

# Steam multi clean

In the following example I will show you how to use multi-clean function.



Cleaning inside the cavity stained with oil or something.

Press **STOP/CLEAR**.

Press **STEAM+ /CLOCK**.

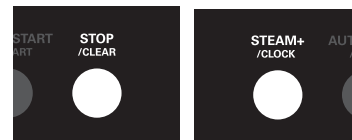

Turn **FUNCTION selection dial** to select **Multi clean**.

The following indication is displayed: "☒☒"



Turn **CONTROL dial** until display shows "1".



Press **ENTER/START/Q-START**.

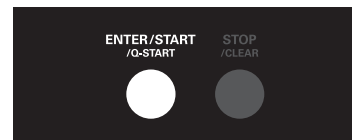

※ **Multi clean**

"1" (Steam Clean) : For cleaning cavity stained with oil or something.

"2" (Drain Water) : For removing residual water in Steam generator.

"3" (Cleaning the Steam generator) : For removing sediment in steam generator.

# EZ Clean

In the following example I will show you how to remove smell in the oven.



The oven has a special function to remove the smell in the oven.

You can use the EZ Clean function without food in the oven.

Press **STOP/CLEAR**.



Turn **FUNCTION selection dial** to select **EZ Clean**.

The following indication is displayed: "  "



Press **ENTER/START/Q-START**.

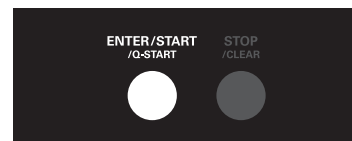

# Quick Start

In the following example I will show you how to set 2 minutes of cooking on high power (700W).



The **Quick Start** feature allows you to set 30 seconds intervals of HIGH power (700W) cooking with pressing of the **ENTER/START/Q-START** button.

Press **STOP/CLEAR**.

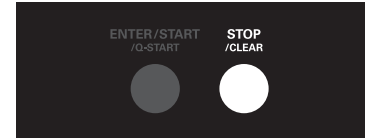

Press **ENTER/START/Q-START** four times to select 2 minutes on HIGH power (700W).  
Your oven will start before you have finished the fourth press.

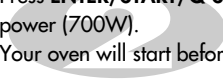



# More or Less Cooking

In the following example I will show you how to change the preset **AUTO COOK** programmes for a longer or shorter cooking time.



If you find that your food is over or undercooked when using the Auto Cook programme, you can increase or decrease cooking time by turning the **CONTROL dial**.

You can lengthen or shorten the cooking time(except defrost mode) at any point by turning the **CONTROL dial**.

Press **STOP/CLEAR**.



Set the required **AUTO COOK** programme.

\*See **AUTO COOK** (page. 36).

Select weight of food.

Press **ENTER/START/Q-START**.

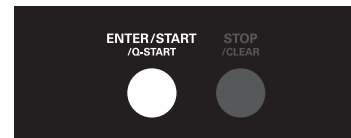

Turn **CONTROL dial**.

The cooking time will increase or decrease.



# How To Clean

## To Clean Your Oven

### 1. Keep the inside of the oven clean

Food spatters or spilled liquids stick to oven walls and between seal and door surface. It is best to wipe up spillovers with a damp cloth right away. Crumbs and spillovers will absorb microwave energy and lengthen cooking times. Use a damp cloth to wipe out crumbs that fall between the door and the frame. It is important to keep this area clean to assure a tight seal. Remove greasy spatters with a soapy cloth then rinse and dry. Do not use harsh detergent or abrasive cleaners. The Metal tray can be washed by hand or in the dishwasher.

### 2. Keep the outside of the oven clean

Clean the outside of your oven with soap and water then with clean water and dry with a soft cloth or paper towel. To prevent damage to the operating parts inside the oven, the water should not be allowed to seep into the ventilation openings. To clean control panel, open the door to prevent oven from accidentally starting, and wipe a damp cloth followed immediately by a dry cloth. Press Stop/Clear after cleaning.

3. If steam accumulates inside or around the outside of the oven door, wipe the panels with a soft cloth. This may occur when the oven is operated under high humidity conditions and in no way indicates a malfunction of the unit.
4. The door and door seals should be kept clean. Use only warm, soapy water, rinse then dry thoroughly.  
DO NOT USE ABRASIVE MATERIALS, SUCH AS CLEANING POWDERS OR STEEL AND PLASTIC PADS.  
Metal parts will be easier to maintain if wiped frequently with a damp cloth.
5. Do not use any steam cleaner.
6. Unplug your oven from the electrical socket when you clean control panel with wet cloth or spray water on control glass to clean. If it's not, this product can be operated by touching Quick Start button.

## To Clean the Cavity

### Cavity front side

After cooking greasy food like fried chicken, wipe the front side of cavity with soft sponge with neutral detergent in the direction of right and left following the texture. And finish it with dry towel. (Inside of the door, remove the grease with sponge or towel.)

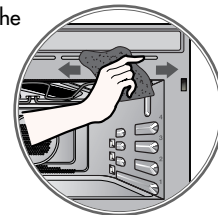

### Cavity inside

- Wipe inside with towel or sponge with neutral detergent, finish it with dry towel.
- If you do not clean inside of cavity for a long time, oil stain might stick to inside and it would be hard to remove and give out bad smell.
- If it is hard to remove water mark around steam outlet on the wall of cavity, you can remove it effectively with sponge with vinegar.
- After cooking with steam, wipe inside of kitchen with dry towel.
- It would be convenient to use steam cleaning function after cooking greasy food like fried chicken or fried fish.

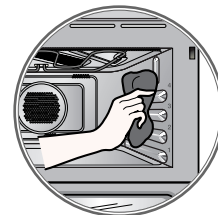

# Microwave-safe Utensils

## **Never use metal or metal trimmed utensils in using microwave function**

Microwaves cannot penetrate metal. They will bounce off any metal object in the oven and cause arcing, an alarming phenomenon that resembles lightning. Most heat resistant non metallic cooking utensils are safe for use in your oven. However, some may contain materials that render them unsuitable as microwave cookware. If you have any doubts about a particular utensil, there's a simple way to find out if it can be used in using microwave function. Place the utensil in question next to a glass bowl filled with water in using microwave function. Microwave at power HIGH for 1 minute. If the water heats up but the utensil remains cool to the touch, the utensil is microwave-safe. However, if the water does not change temperature but the utensil becomes warm, microwaves are being absorbed by the utensil and it is not safe for use in using microwave function. You probably have many items on hand in your kitchen right now that can be used as cooking equipment in using microwave function. Just read through the following checklist.

### **Dinner plates**

Many kinds of dinner-ware are microwave-safe. If in doubt consult the manufacturer's literature or perform the microwave test.

### **Glassware**

Glassware that is heat-resistant is microwave-safe. This would include all brands of oven tempered glass cookware. However, do not use delicate glassware, such as tumblers or wine glasses, as these might shatter as the food warms.

### **Plastic storage containers**

These can be used to hold foods that are to be quickly reheated. However, they should not be used to hold foods that will need considerable time in the oven as hot foods will eventually warp or melt plastic containers.

## **Paper**

Paper plates and containers are convenient and safe to use in using microwave function, provided that the cooking time is short and foods to be cooked are low in fat and moisture. Paper towels are also very useful for wrapping foods and for lining baking trays in which greasy foods such as bacon are cooked. In general, avoid coloured paper products as the colour may run. Some recycled paper products may contain impurities which could cause arcing or fires when used in using microwave function.

## **Plastic cooking bags**

Provided they are made specially for cooking, cooking bags are microwave safe. However, be sure to make a slit in the bag so that steam can escape. Never use ordinary plastic bags for cooking in using microwave function, as they will melt and rupture.

## **Plastic microwave cookware**

A variety of shapes and sizes of microwave cookware are available. For the most part, you can probably use items you already have on hand rather than investing in new kitchen equipment.

## **Pottery, stoneware and ceramic**

Containers made of these materials are usually fine for use in using microwave function, but they should be tested to be sure.

## **CAUTION**

**Some items with high lead or iron content are not suitable for cooking utensils.**

**Utensils should be checked to ensure that they are suitable for use in using microwave function.**

# Food characteristics & Microwave cooking

## Keeping an eye on things

The recipes in the book have been formulated with great care, but your success in preparing them depends on how much attention you pay to the food as it cooks. Always watch your food while it cooks. Your microwave function is equipped with a light that turns on automatically when the oven is in operation so that you can see inside and check the progress of your food. Directions given in recipes to elevate, stir, and the like should be thought of as the minimum steps recommended. If the food seems to be cooking unevenly, simply make the necessary adjustments you think appropriate to correct the problem.

## Factors affecting microwave cooking times

Many factors affect cooking times. The temperature of ingredients used in a recipe makes a big difference in cooking times. For example, a cake made with ice-cold butter, milk, and eggs will take considerably longer to bake than one made with ingredients that are at room temperature. All of the recipes in this book give a range of cooking times. In general, you will find that the food remains under-cooked at the lower end of the time range, and you may sometimes want to cook your food beyond the maximum time given, according to personal preference. The governing philosophy of this book is that it is best for a recipe to be conservative in giving cooking times. While overcooked food is ruined for good. Some of the recipes, particularly those for bread, cake, and custards, recommend that food be removed from the oven when they are slightly undercooked. This is not a mistake. When allowed to stand, usually covered, these foods will continue to cook outside of the oven as the heat trapped within the outer portions of the food gradually travels inward. If the food is left in the oven until it is cooked all the way through, the outer portions will become overcooked or even burnt. You will become increasingly skilful in estimating both cooking and standing times for various foods.

## Density of food

Light, porous food such as cakes and breads cook more quickly than heavy, dense foods such as roasts and casseroles. You must take care when microwaving porous food that the outer edges do not become dry and brittle.

## Height of food

The upper portion of tall food, particularly roasts, will cook more quickly than the lower portion. Therefore, it is wise to turn tall food during cooking, sometimes several times.

## Moisture content of food

Since the heat generated from microwaves tends to evaporate moisture, relatively dry food such as roasts and some vegetables should either be sprinkled with water prior to cooking or covered to retain moisture.

## Bone and fat content of food

Bones conduct heat and fat cooks more quickly than meat. Care must be taken when cooking bony or fatty cuts of meat that they do not cook unevenly and do not become overcooked.

## Quantity of food

The number of microwaves in your oven remains constant regardless of how much food is being cooked. Therefore, the more food you place in the oven, the longer the cooking time. Remember to decrease cooking times by at least one third when halving a recipe.

## Shape of food

Microwaves penetrate only about 2.cm into food, the interior portion of thick foods are cooked as the heat generated on the outside travels inward. Only the outer edge of food is cooked by microwave energy; the rest is cooked by conduction. The worst possible shape for a food that is to be microwaved is a thick square. The corners will burn long before the centre is even warm . Round thin foods and ring shaped foods cook successfully in the microwave.

# Food characteristics & Microwave cooking

## **Covering**

A cover traps heat and steam which causes food to cook more quickly. Use a lid or microwave cling film with a corner folded back to prevent splitting.

## **Browning**

Meats and poultry that are cooked fifteen minutes or longer will brown lightly in their own fat. Food that are cooked for a shorter period of time may be brushed with a browning sauce such as worcestershire sauce, soy sauce or barbecue sauce to achieve an appetizing colour. Since relatively small amounts of browning sauces are added to food the original flavour of the recipe is not altered.

## **Covering with greaseproof paper**

Greaseproofing effectively prevents spattering and helps food retain some heat. But because it makes a looser cover than a lid or clingfilm, it allows the food to dry out slightly.

## **Arranging and spacing**

Individual foods such as baked potatoes, small cakes and hors d'oeuvres will heat more evenly if placed in the oven an equal distance apart, preferably in a circular pattern. Never stack foods on top of one another.

## **Stirring**

Stirring is one of the most important of all microwaving techniques. In conventional cooking, food is stirred for the purpose of blending. Microwaved food, however, is stirred in order to spread and redistribute heat. Always stir from the outside towards the centre as the outside of the food heats first.

## **Turning over**

Large, tall foods such as roasts and whole chickens should be turned so that the top and bottom will cook evenly. It is also a good idea to turn cut up chicken and chops.

## **Placing thicker portions facing outwards**

Since microwaves are attracted to the outside portion of food, it makes sense to place thicker portions of meat, poultry and fish to the outer edge of the baking dish. This way, thicker portions will receive the most microwave energy and the food will cook evenly.

## **Shielding**

Strips of aluminium foil (which block microwaves) can be placed over the corners or edges of square and rectangular foods to prevent those portions from overcooking. Never use too much foil and make sure the foil is secured to the dish or it may cause 'arcing' in the oven.

## **Elevating**

Thick or dense foods can be elevated so that microwaves can be absorbed by the underside and centre of the foods.

## **Piercing**

Foods enclosed in a shell, skin or membrane are likely to burst in the oven unless they are pierced prior to cooking. Such foods include yolks and whites of eggs, clams and oysters and whole vegetables and fruits.

## **Testing if cooked**

Food cooks so quickly in a oven, it is necessary to test it frequently. Some foods are left in the microwave until completely cooked, but most foods, including meats and poultry, are removed from the oven while still slightly undercooked and allowed to finish cooking during standing time. The internal temperature of foods will rise between 5°F (3°C) and 15°F (8°C) during standing time.

## **Standing time**

Foods are often allowed to stand for 3 to 10 minutes after being removed from the oven. Usually the foods are covered during standing time to retain heat unless they are supposed to be dry in texture (some cakes and biscuits, for example). Standing allows foods to finish cooking and also helps flavour blend and develop.

# Questions & Answers

**Q What's wrong when the oven light will not glow?**

- A There may be several reasons why the oven light will not glow.  
Light bulb has blown  
Relay is failed

**Q Does microwave energy pass through the viewing screen in the door?**

- A No. The holes, or ports, are made to allow light to pass; they do not let microwave energy through.

**Q Why does the beep tone sound when a button on the Control Panel is touched?**

- A The beep tone sounds to assure that the setting is being properly entered.

**Q Will the microwave function be damaged if it operates empty?**

- A Yes Never run it empty.

**Q Why do eggs sometimes pop?**

- A When baking, frying, or poaching eggs, the yolk may pop due to steam build up inside the yolk membrane. To prevent this, simply pierce the yolk before cooking. Never microwave eggs in the shell.

**Q Why is standing time recommended after microwave cooking is over?**

- A After microwave cooking is finished, food keeps on cooking during standing time. This standing time finishes cooking evenly throughout the food. The amount of standing time depends on the density of the food.

**Q Why doesn't my oven always cook as fast as the cooking guide says?**

- A Check your cooking guide again to make sure you've followed directions correctly, and to see what might cause variations in cooking time. Cooking guide times and heat settings are suggestions, chosen to help prevent overcooking, the most common problem in getting used to a this oven. Variations in the size, shape, weight and dimensions of the food require longer cooking time. Use your own judgement along with the cooking guide suggestions to test food condition, just as you would do with a conventional cooker.

# Technical Specifications

## Technical Specification

		MP9289VSD
Power Input	230 V~ 50 Hz	
Output	700 W (IEC60705 rating standard)	
Microwave Frequency	2450 MHz	
Outside Dimension	527 mm(W) X 390 mm(H) X 472 mm(D)	
Power	Microwave	1200 watt
	Grill	1900 watt
Consumption	Convection	2200 watt
	Combination	max. 2800 watt

- Microwave Frequency : 2450 MHz +/- 50 MHz (Group 2 / Class B)  
 \*\* Group 2 equipment: group 2 contains all ISM RF equipment in which radio-frequency energy in the frequency range 9 kHz to 400GHz is intentionally generated and used or only used, in the form of electromagnetic radiation, inductive and /or capacitive coupling, for the treatment of material or inspection/analysis purposes. Class B equipment is equipment suitable for use in domestic establishments and in establishments directly connected to a low voltage power supply network which supplies buildings used for domestic purposes.
- You can download a owner's manual at <http://www.lg.com>.

