



OWNER'S MANUAL

Color Video Camera

Please read this manual carefully before operating your set and retain it for future reference.

MODEL

L2304 Series

L2304-DN

L2304-DP



MFL67259823



CAUTION

**RISK OF ELECTRIC SHOCK
DO NOT OPEN**



CAUTION: TO REDUCE THE RISK OF ELECTRIC SHOCK
DO NOT REMOVE COVER (OR BACK)
NO USER-SERVICEABLE PARTS INSIDE
REFER SERVICING TO QUALIFIED SERVICE PERSONNEL.



This lightning flash with arrowhead symbol within an equilateral triangle is intended to alert the user to the presence of uninsulated dangerous voltage within the product's enclosure that may be of sufficient magnitude to constitute a risk of electric shock to persons.



The exclamation point within an equilateral triangle is intended to alert the user to the presence of important operating and maintenance (servicing) instructions in the literature accompanying the product.

FCC WARNING: This equipment may generate or use radio frequency energy. Changes or modifications to this equipment may cause harmful interference unless the modifications are expressly approved in the instruction manual. The user could lose the authority to operate this equipment if an unauthorized change or modification is made.

REGULATORY INFORMATION: FCC Part 15

This equipment has been tested and found to comply with the limits for a Class A digital device, pursuant to Part 15 of the FCC Rules. These limits are designed to provide reasonable protection against harmful interference when the equipment is operated in a commercial environment.

This equipment generates, uses, and can radiate radio frequency energy and, if not installed and used in accordance with the instruction manual, may cause harmful interference to radio communications.

Operation of this equipment in a residential area is likely to cause harmful interference in which case the user will be required to correct the interference at his own expense.

- A suitable conduit entries, knock-outs or glands shall be provided in the cable entries of this product in the end user.

- **Caution:** Danger of explosion if battery is incorrectly replaced. Replaced only with the same or equivalent type recommended by the manufacturer. Dispose of used batteries according to the manufacturer's instructions.
- Holes in metal, through which insulated wires pass, shall have smooth well rounded surfaces or shall be provided with brushings.

This Class A digital apparatus complies with Canadian ICES-003.
Cet appareil numérique de la classe A est conforme à la norme NMB-003 du Canada.

Warning: Do not install this equipment in a confined space such as a bookcase or similar unit.

Warning: Wiring methods shall be in accordance with the National Electric Code, ANSI/NFPA 70.

Warning: This is a class A product. In a domestic environment this product may cause radio interference in which case the user may be required to take adequate measures.

Warning: To reduce a risk of fire or electric shock, do not expose this product to rain or moisture.

Caution: This installation should be made by a qualified service person and should conform to all local codes.

Caution: To avoid electrical shock, do not open the cabinet. Refer servicing to qualified personnel only.

Caution: The apparatus shall not be exposed to water (dripping or splashing) and no objects filled with liquids, such as vases, shall be placed on the apparatus.

To disconnect power from mains, pull out the mains cord plug. When installing the product, ensure that the plug is easily accessible.

Disposal of your old appliance



1. All electrical and electronic products should be disposed of separately from the municipal waste stream via designated collection facilities appointed by the government or the local authorities.
2. The correct disposal of your old appliance will help prevent potential negative consequences for the environment and human health.
3. For more detailed information about disposal of your old appliance, please contact your city office, waste disposal service or the shop where you purchased the product.
4. EEE Compliance with Directive.
(for Turkey only)



LG Electronics hereby declares that this/these product(s) is/are in compliance with the essential requirements and other relevant provisions of Directive 2004/108/EC and 2011/65/EU.

European Standards Centre:

Krijgsmann 1, 1186 DM Amstelveen The Netherlands

- Please note that this is NOT a Customer Service contact point. For Customer Service Information, see Warranty Card or contact the dealer that you purchased this product.

Important Safety Instructions

1. Read these instructions.
2. Keep these instructions.
3. Heed all warnings.
4. Follow all instructions.
5. Do not use this apparatus near water.
6. Clean only with dry cloth.
7. Do not block any ventilation openings. Install in accordance with the manufacturer's instructions.
8. Do not install near any heat sources such as radiators, heat registers, stoves, or other apparatus (including amplifiers) that produce heat.
9. Do not defeat the safety purpose of the polarized or grounding-type plug. A polarized plug has two blades with one wider than the other. A grounding type plug has two blades and a third grounding prong. The wide blade or the third prong are provided for your safety. If the provided plug does not fit into your outlet, consult an electrician for replacement of the obsolete outlet.
10. Protect the power cord from being walked on or pinched particularly at plugs, convenience receptacles, and the point where they exit from the apparatus.
11. Only use attachments/accessories specified by the manufacturer.
12. Use only with the cart, stand, tripod, bracket, or table specified by the manufacturer, or sold with the apparatus. When a cart is used, use caution when moving the cart/apparatus combination to avoid injury from tip-over.
13. Unplug this apparatus during lightning storms or when unused for long periods of time.
14. Refer all servicing to qualified service personnel. Servicing is required when the apparatus has been damaged in any way, such as power-supply cord or plug is damaged, liquid has been spilled or objects have fallen into the apparatus, the apparatus has been exposed to rain or moisture, does not operate normally, or has been dropped.



Cautions for Safe Operation

Power Supply

This camera must always be operated DC 12 V. Certified/ Listed Adaptor which comply with LPS.

Handling of the unit

Be careful not to spill water or other liquids on the unit. Be cautious not to get combustible or metallic material inside the body. If used with foreign matter inside, the camera is liable to fail or to get cause of fire or electric shock.

- Remove dust or dirt on the surface of the lens with a blower.
- Use a dry soft cloth to clean the body. If it is very dirty, use a cloth dampened with a small quantity of neutral detergent then wipe dry.
- Avoid the use of volatile solvents such as thinners, alcohol, benzene and insecticides. They may damage the surface finish and/or impair the operation of the camera.

Operating and storage location

Avoid viewing a very bright object (such as light fittings) during an extended period. Avoid operating or storing the unit in the following locations.

- Extremely hot or cold places (operating temperature -10°C to 50°C , however, we recommend that the unit be used within a temperature range of 0°C to 45°C)
- Damp or dust place
- Places exposed to rain
- Places subject to strong vibration
- Close to generators of powerful electromagnetic radiation such as radio or TV transmitters.

Contents

Introduction 8

Features 8

Unpacking 8

Part Names and Functions 9

Connections 10

Precautions 10

Connection Overview 10

Connecting Display device 11

Connecting Power Source 11

Installation 12

Menu Operation 15

OSD Menu control buttons 15

OSD Menu Overview 16

Specification 32

Introduction

Features

This Camera is designed for installation in an video surveillance system.

This manual contains instructions on how to install and manage the Color Video Camera in your video surveillance system. Should you require any technical assistance, please contact authorized service center.

- High resolution and high sensitivity with a 6 mm CCD.
- 650 TV lines of horizontal resolution.
- BLC covers various light conditions
- Excellent signal-to-noise ratio of 50 dB

Unpacking

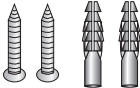
Camera Body	
M3 Tapping Screws (2 EA) (Pan Lock Screw)	

Part Names and Functions

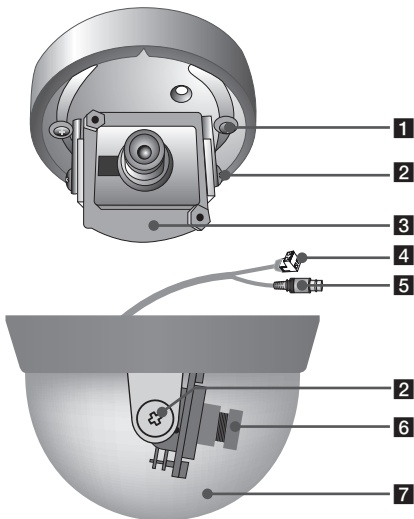

- 1 Pan lock screw**
Fixes the pan position after adjusting.
- 2 Tilting lock screw**
Fixes the tilting position after adjusting.
- 3 Tilt Base**
Adjust the tilting position.
- 4 Power input terminal**
Supplies DC 12 V only from an external power source.
- 5 Video output connector (BNC type)**
Supplies analog video signal (composite) to the connected device such as a DVR or monitor.
- 6 Lens**
- 7 Dome Cover**

Connections

Precautions

- Be sure to switch off the unit before installation and connection.
- A qualified service person, complying with all applicable codes, should perform all required hardware installation.
- Do not expose the power and connection cable to moisture, which may cause damage to the unit.

Connection Overview

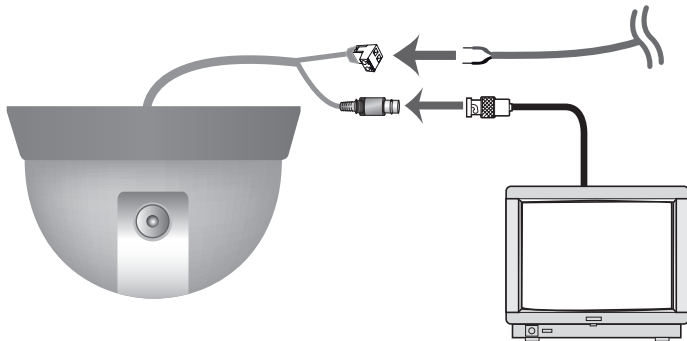

Connections

Connecting Display device

The video signal connection between the camera and the monitor.

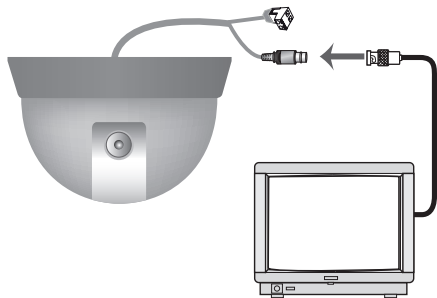

Connecting Power Source

Connect the Power Adapter (12 V, 300 mA; optional) to the Power Input Jack of the camera.

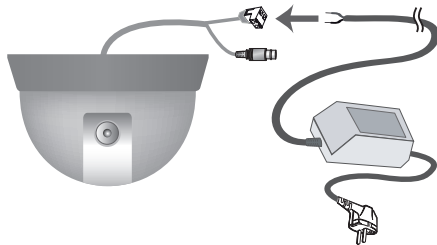

Installation

Follow the instructions below to install the camera.

1. Use the installation guide template to check the mounting location. Face the front of the label toward the area of interest. Using the template as a guide, make a hole through the ceiling.

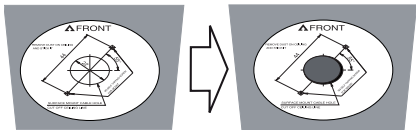

2. Pass the connection cable through the inner side of the ceiling.

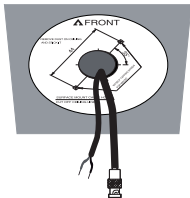

3. Disassemble the Dome Cover from the main body by turning it counterclockwise.

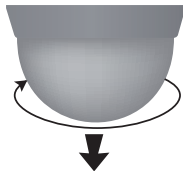

4. Detach the Lens cover.

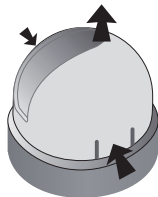

Connections

5. Connect the cables to the cable jacks of the camera body.

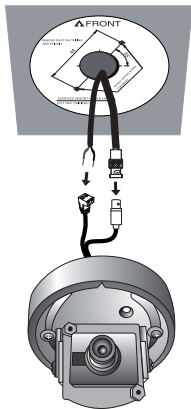

6. Aim the LG logo of the camera to face the same place of the Installation Guide Template. Install the camera by using the M3 Tapping screws to fix it on the ceiling.

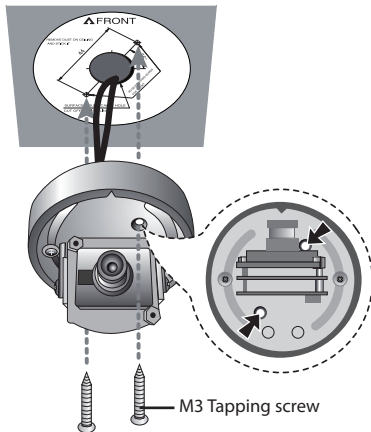

Connections

7. Loosen the Tilting Lock Screw. Adjust the Tilt (Up/Down) position and then tighten Tilting Lock Screw.

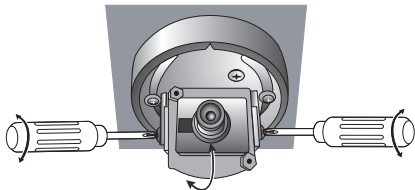

Note:

If you need to adjust the Pan, loose the Pan Lock Screw. Adjust the Pan (Left/Right) then tight the Pan Lock Screw.

8. Attach the Lens Cover and then assemble the Dome Cover to the main body by turning it clockwise.

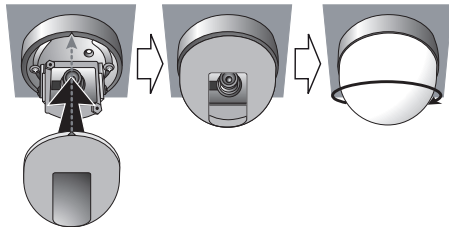

Notes

- When you install the camera, handle with care. The camera could be damaged by improper handling or storage.
- If this camera is mounted on the other places except ceiling, you need an extra bracket for mounting. (not supplied)

Menu Operation

OSD Menu control buttons

This camera utilizes an on-screen user MENU. To set items on the menu, use the following buttons.

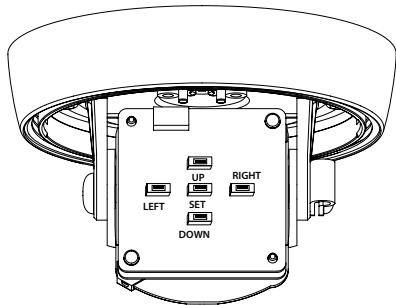

BUTTON	Description
UP	Used to move upper direction on the menu screen. Use this button to select an item or adjust the parameters.
DOWN	Used to move lower direction on the menu screen. Use this button to select an item or adjust the parameters.
RIGHT	Moves the cursor to the right. Used to increment the value selected in the menu. The parameter changes each time this button is pressed.
LEFT	Moves the cursor to the left. Used to decrement the value selected in the menu. The parameter changes each time this button is pressed.
SET	Executes selections and displays a submenu for an item with the  mark.

Menu Operation

OSD Menu Overview

The following table shows the list of menu items and options. You can adapt the camera to your requirements by setting up the respective items in these menus.

MAIN MENU	SUB MENU		CONTENTS	
SHUTTER/AGC	AUTO	HIGH LUMINANCE	MODE	SHUT
			BRIGHTNESS	0 to 255
		LOW LUMINANCE	MODE	AGC/OFF
			BRIGHTNESS	x0.25,x0.5,x.0.75,x1.0
	MANUAL	SHUTTER	MODE	SHUT+AGC
				NTSC: 1/60, 1/100, 1/250, 1/500, 1/1000, 1/2000, 1/4000, 1/10 000
				PAL: 1/50, 1/120, 1/250, 1/500, 1/1000, 1/2000, 1/4000, 1/10 000
		AGC	6.00,12.00,18.00,24.00,30.00,36.00,42.00,44.80	

Menu Operation

WHITE BAL	ATW	SPEED	0 to 255
		DELAY CNT	0 to 255
		ATW FRAME	x0.5,x1.0,x1.5,x2.0
		ENVIRONMENT	INDOOR,OUTDOOR
	PUSH	-	
	USER1	B-GAIN	0 to 255
		R-GAIN	0 to 255
	USER2	B-GAIN	0 to 255
		R-GAIN	0 to 255
	ANTI CR	-	
MANUAL	LEVEL 29 to 79		
PUSH LOCK	-		
BACKLIGHT	OFF	-	
	BLC	-	
	HLC	-	

Menu Operation

DAY/NIGHT	AUTO	BURST	ON/OFF
		DELAY CNT	0 to 255
		DAY→NIGHT	0 to 255
		NIGHT→DAY	0 to 255
	COLOR	-	
B/W	BURST	ON/OFF	
ATR	OFF		-
	ON	LUMINANCE	LOW/MID/HIGH
		CONTRAST	LOW/MIDDLELOW/MID/MIDDLEHIGH/HIGH
NR	NR MODE		Y/C,OFF,Y,C
	Y LEVEL		0 to 15
	C LEVEL		0 to 15

Menu Operation

MOTION DETECTION	OFF		-		
	ON	DETECT SENSE	0 to 127		
		BLOCK DISP	OFF/ON/ENABLE		
		MONITOR AREA	ON/OFF		
		AREA SEL (1 to 4)	TOP	0 to 244(NTSC), 0 to 288(PAL)	
			BOTTOM	0 to 244(NTSC), 0 to 288(PAL)	
			LEFT	0 to 474(NTSC), 0 to 468(PAL)	
RIGHT	0 to 474(NTSC), 0 to 468(PAL)				
PRIVACY	OFF		-		
	ON	AREA SEL (1 to 4)	TOP	0 to 244(NTSC), 0 to 288(PAL)	
			BOTTOM	0 to 244(NTSC), 0 to 288(PAL)	
			LEFT	0 to 474(NTSC), 0 to 468(PAL)	
			RIGHT	0 to 474(NTSC), 0 to 468(PAL)	
		COLOR	1 to 8		
		TRANSPARENT	0.00, 0.50, 0.75, 1.00		
		MOSAIC	ON/OFF		

Menu Operation

PICT ADJUST	MIRROR	OFF/ON	
	BRIGHTNESS	0 to 255	
	CONTRAST	0 to 255	
	SHARPNESS	0 to 255	
	HUE	0 to 255	
	GAIN	0 to 255	
CAMERA ID	OFF	-	
	ON	-	
SYNC	INT	-	
LANGUAGE	-	English (The option depends on the model.)	
CAMERA RESET	-	-	
SAVE ALL	-	-	
EXIT	-	-	

Menu Operation

General Operation

1. Press [SET] button. The setup menu screen appears.

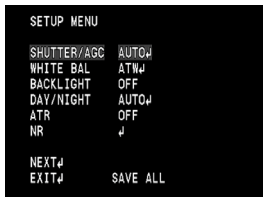

2. Use [UP] or [DOWN] button to select an option then press [SET] button. Submenu appears on the monitor.
3. Use [LEFT] or [RIGHT] button to select a value.
4. Click [NEXT] button to select next option. Use [BACK] button to return the previous setup menu.
5. Select [EXIT] option then press [SET] to exit the setup menu. In the submenu, use [UP] or [DOWN] button to select the [RETURN] then press [SET] to return to the previous setup menu. If you want to save settings, selects [SAVE ALL] option.

- RETURN: Return to the previous.

SHUTTER/AGC Setting

Select the desired shutter speed for camera exposure. And if the images are too dark, change the maximum AGC value to make the images brighter. You can change the shutter speed to higher speed to capture fast-moving subjects, though the image becomes darker.

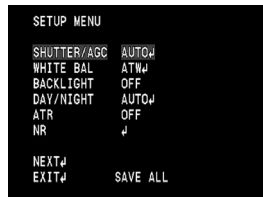

1. Select [SHUTTER/AGC] option.
2. Use [LEFT] or [RIGHT] button to select a mode.

Menu Operation

- **AUTO:** Use for masking brightness of the specific area to view the subject more clearly. You can select both high luminance and low luminance scene.

High Luminance	Low Luminance
<ul style="list-style-type: none">> MODE: This option is fixed to SHUT.> BRIGHTNESS: You can increase the brightness of the darkened video. If you set the brightness to lower value, the image gets darkened. If you set the brightness to higher value, the image gets bright.	<ul style="list-style-type: none">> MODE: You can select the mode between AGC and OFF.> BRIGHTNESS: You can increase the brightness of the darkened video. If you set the brightness to lower value, the image gets darkened. If you set the brightness to higher value, the image gets bright.

- **MANUAL:** You can set the Shutter and AGC options manually.
 - > **MODE:** This option is fixed to SHUT+AGC.
 - > **SHUTTER:** Select the desired shutter speed for camera exposure. You can change the shutter speed to higher speed to capture fast-moving subjects, though the image becomes darker.
 - > **AGC:** If the images are too dark, change the maximum [AGC] value to make the images bright.

Menu Operation

White Balance Setting

Select the method by which the camera shifts its output colors to compensate for the color of a light source.

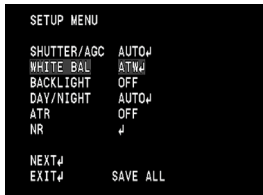

- ATW (Auto-Tracing White Balance): The color temperature range for the proper white balance is approximately 1 800 K to 10 500 K. Proper white balance may not be obtained under the following conditions:
 - > The color temperature is out of the 1 800 K to 10 500 K range.
 - > the scene contains mostly high color temperature objects, such as a blue sky or sunset.
 - > When the scene is dim.

- > SPEED: Use [LEFT] or [RIGHT] to set the ATW pull-in speed. If you select high value, ATW pull-in speed becomes higher.

Note:

The default value of “Speed” is enough and the best for user to use, when “Speed” is highest, “DELAY CNT” and “ATW Frame” will be neglectable.

- > DELAY CNT: You can adjust the time-based hysteresis of ATW.
- > ATW FRAME: You can set the AFW frame value. If you set frame value high, the tracking will be faster.
- > ENVIRONMENT: Use [LEFT] or [RIGHT] button to select a function. (OUTDOOR is set on the assumption that outdoor light sources (mainly sunlight) will be used for shooting; INDOOR is set on the assumption that indoor light sources (mainly sodium vapor lamps and indoor lights) will be used for shooting.)
- PUSH: If you select the PUSH mode, you will be able to set up the White Balance automatically using [SET] button.

Menu Operation

- USER: You can set the white balance options.
 - > B-GAIN: Obtains the optimum amount of blue gain.
 - > R-GAIN: Obtains the optimum amount of red gain.
- MANUAL: You can set the white balance options manually. The actual variable range is limited to the range from the low color temperature (approximately 1 800K) to the high color temperature (approximately 10 500K) stored when the pre-white balance was adjusted.
- ANTI CR: This function minimizes the color changes (color rolling) over long periods caused by very small differences between the flicker frequency of non-inverter fluorescent lights and the drive frequency of the image sensor devices.
- PUSH LOCK: If you select the PUSH LOCK mode, you prevent to set up the White Balance automatically by using [SET] button.

Backlight Setting

Use BACKLIGHT option to view the object clearly in backlight conditions.

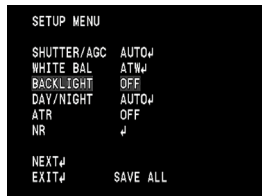

1. Select [BACKLIGHT] option.
2. Use [LEFT] or [RIGHT] button to select a mode then press [SET].
 - BLC: Camera's backlight compensation feature helps alleviate issues of visibility in high contrast areas.
 - HLC: Use for masking brightness of the specific area to view the subject more clearly. The HLC mode is automatically activated only in low luminance scene.

Menu Operation

Day/Night Setting

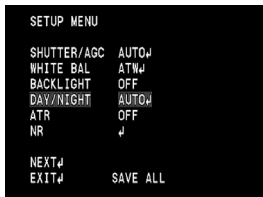

1. Select [DAY/NIGHT] option.
2. Use [LEFT] or [RIGHT] button to select mode for Day/Night function.
 - AUTO: You will be able to change the Day/Night mode automatically.
 - > BURST: Select [ON] or [OFF] to set the color burst in Night status.
 - > DELAY CNT: You can set the judgment time for the transition between the Day and Night.
 - > Night→Day: Transition point set to Night to Day.

- > Day→Night: Transition point set to Day to Night.
- Color: Color mode enabled.
- B/W: Black-and-white mode enabled.

Menu Operation

ATR (Adaptive Tone Reproduction) Setting

Adaptive Tone Reproduction is the mapping of scene luminance and color to print reflectance or display luminance. It is order to reproducing brightness properly and brightness differences.

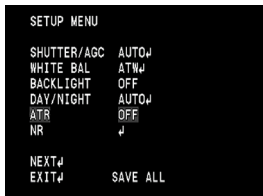

1. Select [ATR] option and use [LEFT] or [RIGHT] button to select ON or OFF.
2. Use [LEFT] or [RIGHT] button to select a mode then press [SET].
 - LUMINANCE: You can select the Luminance limit.
 - CONTRAST: You can select the Contrast limit.

NR Setting

If you select high value, you can reduce the more noise. When you use this function, the afterimage may occur.

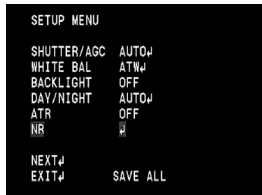

1. Select [NR] option. If pictures are not clear due to brightness, this option reduce the noise of picture.
2. Use [LEFT] or [RIGHT] button to select the option.
 - NR Mode: You can select the filter mode of 2D-DNR.
 - > Y LEVEL: If you select the Y Level, you can set the Y basic filter for 2D-NR.
 - > C LEVEL: If you select the C Level, you can set the C basic filter for 2D-NR.

Menu Operation

Motion Detection Setting

The motion detection detects the moving objects in the scene by monitoring changes in brightness level.



1. Select [MOTION DET] option.
2. Use [LEFT] or [RIGHT] button to select [ON] and press [SET]. The MOTION DETECTION menu appears.
3. Use [LEFT] or [RIGHT] button to select a Detect Sense from 0 to 127.
4. Use [LEFT] or [RIGHT] button to set up the ON or OFF on the Block Display.
5. Use [LEFT] or [RIGHT] button to set up the ON or OFF on the Monitor Area.

6. Use [UP] or [DOWN] to select an Area Select option from 1 to 4 then use [LEFT] or [RIGHT] button to adjust the option.
 - TOP: Moves top position on the screen.
 - BOTTOM: Moves bottom position on the screen.
 - LEFT: Moves left position on the screen.
 - RIGHT: Moves right position on the screen.

Note:

When the TOP and BOTTOM value is the same, the block wouldn't be shown. And increase the top value, the bottom value would increase too, you could set it after fixing the top value. While decrease the bottom value, the top value would decrease too. LEFT and RIGHT relation is similar too.

Menu Operation

Privacy Setting

This function is aiming at the protection of personal privacy, selecting a screen part black or other color not to be displayed in the screen. 4 areas can be registered.

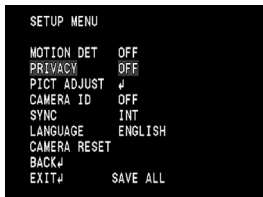

1. Select [PRIVACY] option.
2. Use [LEFT] or [RIGHT] button to select a [ON] and press [SET]. The PRIVACY SETUP menu appears.
3. Use [LEFT] or [RIGHT] button to select the Area Selection (1 to 4) on the [AREA SEL].
 - TOP: Moves top position on the screen.
 - BOTTOM: Moves bottom position on the screen.
 - LEFT: Moves left position on the screen.

- RIGHT: Moves right position on the screen.
4. Use [LEFT] or [RIGHT] button to set up 1 to 8 from COLOR option.
 5. Use [LEFT] or [RIGHT] button to set up TRANSP option.
 6. Use [LEFT] or [RIGHT] button to set up MOSAIC option.

Menu Operation

Picture Adjust Settings



- GAIN: Edit the video color gain of the camera from 0 to 255.
- MIRROR: Turn on the mirror effect.
- BRIGHTNESS: You can increase the brightness of the darkened video. If you set the brightness to lower value, the image is darkened. If you set the brightness to higher value, the image gets bright.
- CONTRAST: Edit the contrast value from 0 to 255. Selecting 255 provides the image with the highest contrast.
- SHARPNESS: You can select the sharpness effect.
- HUE: Edit the video Hue of the camera from 0 to 255.

Menu Operation

Camera ID Setting

You can use the camera identification to assign a number and character to the camera. The CAMERA ID is displayed on the upper left of the screen. To disappear from the CAMERA ID, select [OFF].



1. Select [CAMERA ID] menu.
2. Use [LEFT] or [RIGHT] button to select a [ON] then press [SET]. The CAMERA ID menu appears.
 - CLR: If you enter the wrong code, select CLR then press [SET].
 - POS: Use [UP], [DOWN], [LEFT] or [RIGHT] button to move position of CAMERA ID on the screen.
 - **1** (Blank): Inserts a space at the cursor position.

- / : Moves cursor to left or right.

SYNC Setting

The line lock function is available only with AC power source. When you use the DC 12 V power, the [SYNC] option is fixed to [INT] mode only.



Menu Operation

Language Setting

Select the viewer language for the camera setup menu.



1. Select [LANGUAGE] menu.
2. Press [LEFT] or [RIGHT] button to select a language.

Camera Reset Setting



- CAMERA RESET: To reset the camera setting to initial setup, select [CAMERA RESET] option.

Specification

ITEM	L2304-DP	L2304-DN
Signal System	PAL	NTSC
Total Pixels No./ Effective Pixels No.	610 000 Pixels / 570 000 Pixels	520 000 Pixels / 480 000 Pixels
Image Device	6 mm CCD	
Signal Process	Sony Effio-E	
Lens	Fixed Lens	
IRIS Control	ELC	
Sync. System	Internal	
Scanning Frequency (H/V)	15.625 kHz / 50 Hz	15.734 kHz / 59.94 Hz
Horizontal Resolution	650 TV Lines	
S/N Ratio	50 dB	

Specification

ITEM	L2304-DP	L2304-DN
Minimum Illumination	0.1 lx (F1.2, 30 IRE)	
Video Output Signal	1 Vp-p Composite (75 Ω)	
Day & Night	Digital (AUTO / DAY / NIGHT)	
Backlight	OFF/BLC/HLC	
DNR	2D-DNR	
Electronic Shutter Speed	1/50 to 1/10 000	1/60 to 1/10 000
White Balance	ATW/PUSH/USER1/USER2/ANTI CR/MANUAL/PUSH LOCK	
Power Source	DC 12 V	
Power Consumption	100 mA	
Operation Temp.	-10 °C to 50 °C	
Storage Temp.	-20 °C to 60 °C	

Specification

ITEM	L2304-DP	L2304-DN
Operation Humidity	0 % RH to 80 % RH	
Storage Humidity	0 % RH to 85 % RH	
Weight	165 g	
Dimension (Ø x H)	88 mm x 67.5 mm	

