



使用手冊 OWNER'S MANUAL

VS84** Series



MFL67983111

www.lg.com

LG 無線直立式吸塵器

本說明書包含真空吸塵器安全使用和維護的重要資訊和說明。為了您的安全，請閱讀第 4、5 和 6 頁上的所有資訊。請將本說明書置於容易觸及的位置，以作日後參考之用。

LG CORDLESS HANDY-STICK CLEANER

This manual contains important information and instructions for the safe use and maintenance of the vacuum cleaner. Please read all of the information on page 7, 8, 9 for your safety. Please keep this manual in an easily accessible place for future reference.

目錄

Table of contents

重要安全說明	4~6
Important safety instructions	7~9
元件與功能	10
Components and functions	
使用方法	11~19
How to use	
組裝真空吸塵器	11
Assembling vacuum cleaner	
組裝充電器	12
Assembling Charger	
使用本產品	13~15
Using the Product	
充電	16
Charging	
清潔集塵筒	17
Cleaning Dust bin	
組裝集塵筒	18
Assembling Dust bin	
清潔吸嘴	19
Cleaning Nozzle	
注意事項	20
Troubleshooting Guide	21

重要安全說明

在您使用真空吸塵器之前，請閱讀並遵守所有說明，以防止在使用真空吸塵器時出現火災、觸電、人身傷害或財產損失等風險。本指南不包含可能出現的所有可能情況。若存在無法理解的問題，請務必聯絡您的服務代理商或製造商。此電器符合下列 EC 指令：-2006/95/EC 低電壓指令，-2004/108/EC EMC 指令。



這是安全警示符號。

此符號提醒您注意可能傷害您和其他人或可能致命的潛在危險。

所有的安全訊息均將顯示在安全警示符號和「警告」或「注意事項」文字之後。

「警告」或「注意事項」的涵義：



警告

此符號將提醒您注意可能造成嚴重人身傷害或死亡的危險或不安全行為。



注意事項

此符號將提醒您注意可能造成人身傷害或財產損壞的危險或不安全行為。



警告

1. 身體、感知或心理能力較弱者或缺乏經驗及知識的人群 (包括兒童) 不宜使用該電器，除非有負責其安全的人員給予有關使用該電器的監督或指引。
2. 應監督兒童，避免其把玩該電器。
3. 如電源線損壞，請務必由 LG 電子產品服務代理商更換，以免造成危險。
4. 8 歲以下的兒童和身體、精神或感知能力有缺陷的人，以及沒有操作經驗者和對此設電器知識不足的人，需在監督或得到有關安全使用該產品並理解其危險的指導後方可使用。

重要安全說明

警告

- 本電器專為正常室內家用而設計。本電器非供用於任何辦公或商業應用之中。
- 僅維修技術人員才可拆卸或修改本產品。否則可能會造成火災或觸電。
- 請勿在吸塵器及其充電座附近噴灑汽油或溶劑等易燃材料、清潔劑或沐浴產品等表面活性劑或各種飲料。否則可能造成爆炸或火災。
- 請勿使電源線遭到重物擠壓、扭結或切割。使用損壞的電源線或插頭可能會造成火災或觸電。電源線損壞時十分危險，請由獲授權的服務中心進行更換。
- 請勿讓水等液體進入本產品，並請勿使用本裝置吸取液體、尖銳物品或熱灰燼。否則可能造成火災或觸電。若不慎使水進入本裝置，請立即關閉主機身電源開關並拔掉電源插頭，然後聯絡 LG 電子產品服務代理商以避免發生危險。
- 請勿在吸塵器及其充電座內部或附近插入別針或尖銳器具。否則有觸電的風險。
- 若可偵測到氣體氣味，則請勿使用該電器。拔下本裝置的電源插頭並進行通風，以避免可能的危險。否則有火災或爆炸的風險。
- 請確定本裝置插入電流超過 10amp 且未過載的牆壁插座之中。任何牆壁插座的過載均可導致火災和產品故障。
- 若電源線或插座出現任何鬆動或損壞，請勿使用本電器。否則可能造成火災或觸電。
- 請勿在吸入口或出口堵塞的情況下使用本電器。否則會導致主機身變形或由於過熱而導致火災。
- 在取出集塵筒時。請勿使用吸塵器否則有產品損壞或觸電受傷的風險。
- 請勿將電源線和本產品放在加熱裝置附近。否則可造成機身變形、故障或火災。
- 請注意，當您從電源插座上拔下插頭時，請勿用手指觸摸插針。否則可造成觸電。
- 請勿讓兒童或寵物把玩本產品或將本產品作為玩具使用。否則可造成人身傷害或本裝置損壞。
- 請勿用濕手觸摸電源插頭。否則可能會造成觸電。
- 請勿用水清洗入口並且在弄乾元件之後立即使用本產品。否則可能會造成觸電和故障。
- 當您清潔本產品外部時，請確保拔出電源插頭並且勿使用刺激性強的溶液或腐蝕性溶液進行清洗。否則可造成觸電與外部損壞。
- 在電器運作時，請勿將雙手置於電器的吸入口內。使本裝置停止運作並與牆壁插座中斷連接以避免任何人身傷害。
- 請勿用水或清潔劑清洗入口或底面的外部。僅可使用濕抹布。否則可能會損壞產品或造成觸電。
- 若電源線損壞，必須由製造商或其服務代理商或類似合格人員進行更換，以避免危險發生。
- 請勿在有大量工業油煙或金屬微粒的場所使用本產品。否則可能會造成火災或產品故障。
- 請勿在有易燃氣體洩漏或可能有易燃氣體洩漏的場所使用本產品。否則可能會造成火災或爆炸。
- 請勿拆卸電池。否則有火災或爆炸的風險。
- 請勿使本產品暴露於熱或火焰下。請勿使本產品暴露於直射的陽光。否則有火災和爆炸的風險。
- 請勿對電池給予物理衝擊。否則有火災和爆炸的風險。
- 僅可使用指定的充電器充電。**(產品包裝箱中包含原廠變壓器)**請勿將隨附的變壓器與其他產品搭配使用，或將變壓器用於預期使用目的以外的其他用途。請採用正確方式充電。電池可能受損並且可能造成火災。
- 若電池內洩漏出任何液體，請避免接觸皮膚或眼睛。若您碰觸到電池液，請用大量清水沖洗接觸部位並取得醫療照護。否則有燒傷和失明的風險。

重要安全說明

⚠ 注意事項

- 請勿在額定電壓之外使用本吸塵器。否則可能會造成火災和無法修復的產品損壞。
- 若產品長時間不使用，請拔下電源插頭。
- 在清潔過程中，機身上可能產生靜電。吸塵器可能會由於靜電能而出現故障，因此請拔出電源線然後再將其放回。
- 在清潔過程中，短襪、長襪、紙巾等較大物件可能阻塞入口，因此在開始清潔之前請先將其清除。
本電器僅可用於清除灰塵。
- 請勿將本裝置停在一個地方或長時間重複使用於同一個地方。
否則使用表面可能會由於摩擦和震動而受損。
- 在本電器運作時，請勿使手腳碰觸到電器底面。
- 請勿在未裝好集塵筒和外蓋時操作本電器。請務必確保在集塵筒容量達到其極限時或之前對其進行清理。
若在集塵筒已滿情況下繼續使用本電器，則將導致故障與過熱。
- 為避免火災或觸電的風險，在移除插頭時請務必抓住插頭。並且在從牆壁插座上拔下插頭時，切勿拉拽電源線。
- 若集塵筒底面附有異物，請在使用本產品之前將其清除。
否則可能會使抽吸馬達性能減弱並且造成故障和損壞。
- 切勿將本產品用於清除有毒氣體。
否則本產品可能故障並且無法去除有毒氣體。
- 請在平坦區域使用或放置本裝置，並且勿向本裝置施力。否則可能會造成火災或產品故障。
- 請以正確方式處置本產品。
否則有火災和爆炸的風險。

IMPORTANT SAFETY INSTRUCTIONS

Read and follow all instructions before using your vacuum cleaner to prevent the risk of fire, electrical shock, personal injury, or damage when using the vacuum cleaner. This guide does not cover all possible conditions that may occur. Always contact your service agent or manufacturer about problems that you do not understand. This appliance complies with the following EC Directives :-2006/95/EC Low Voltage Directive -2004/108/EC EMC Directive.



This is the safety alert symbol.

This symbol alerts you to potential hazards that can kill or hurt you and others.

All safety messages will follow the safety alert symbol and either the word "WARNING" or "CAUTION."

These words mean:



This symbol will alert you to hazards or unsafe practices which could cause serious bodily harm or death.



This symbol will alert you to hazards or unsafe practices which could cause bodily injury or property damage.

WARNING

1. This appliance is not intended for use by persons (including children) with reduced physical, sensory or mental capabilities, or lack of experience and knowledge, unless they have been given supervision or instruction concerning use of the appliance by a person responsible for their safety.
2. Children should be supervised to ensure that they do not play with the appliance.
3. If the supply cord is damaged, it must be replaced by LG Electronics Service Agent in order to avoid a hazard.
4. This appliance can be used by children aged from 8 years and above and persons with reduced physical, sensory or mental capabilities or lack of experience and knowledge if they have been given supervision or instruction concerning use of the appliance in a safe way and understand the hazards involved. Children shall not play with the appliance. Cleaning and user maintenance shall not be made by children without supervision.

IMPORTANT SAFETY INSTRUCTIONS

WARNING

- **This appliance is designed for normal indoor domestic use only. It is not to be used for any office or commercial application.**
- **No one other than a repair technician shall disassemble or modify the product.**
It may cause fire or electrical shock.
- **Do not spray combustible materials such as gasoline or solvents, or surfactants such as detergents or bathing goods, or drinks near the cleaner and its charging stand.**
It can cause an explosion or fire.
- **Do not allow the power cord to be crushed, kinked or cut by heavy objects.**
Using a damaged cord or plug could cause fire or electrical shock. When the power cord is damaged, it is dangerous, so please have the cord replaced by an authorised service center.
- **Do not let liquid such as water enter the product, and do not use the unit to pick up liquids, sharp pointy objects, or hot embers.**
It causes fire or electrical shock.
If water accidentally enters the unit, immediately turn off the power switch of the main body, pull out the power plug, and contact LG Electronics Service Agent to avoid hazard.
- **Do not insert pins or sharp pointy utensils into or around the cleaner or its charging stand.**
There is a risk of electrical shock.
- **Do not use the appliance if gas odors can be detected. Unplug the unit and provide ventilation to avoid possible dangers.**
There is a risk of fire or explosion.
- **Make sure that the unit is plugged into a wall socket over 10amp and not overloaded.**
Overloading of any wall socket can cause fires and product malfunction.
- **Do not use the appliance if the power cord or socket is in any way loose or damaged.**
It can cause fire or electrical shock.
- **Do not operate the appliance with the suction inlet or outlet which are blocked.**
It causes deformation of main body or fire by overheating.
- **Do not operate the cleaner while dust bin is taken out.**
There is a risk of product damage or electrical shock injury.
- **Do not place power cord and the product near heating devices.**
It can cause deformation of main body, malfunction, or fire.
- **Be careful that your fingers do not touch the pins when you pull out the plug from the mains outlet.**
It can cause electrical shock.
- **Do not allow children or pets to play with the product or use the product as a toy.**
It can cause personal injury and damage to the unit.
- **Do not handle the plug with wet hands.**
It may cause electrical shock.
- **Do not clean the inlet with water and then use immediately without sufficiently drying the components first.**
It may cause electrical shock and malfunction.
- **When you clean the exterior, make sure to pull out the power plug, and do not wash with harsh or abrasive solutions.**
It can cause electrical shock and exterior damage.
- **Do not place hands into the intake while the appliance is operating. Allow the unit to stop operating and disconnect from the wall socket to avoid any personal injury.**
- **Do not wash the exterior of inlet or bottom surface with water or detergent. Use only a damp cleaning cloth.**
It may damage product or cause electrical shock.
- **If the supply cord is damaged, it must be replaced by the manufacturer, its authorised service agent or similarly qualified persons in order to avoid a hazard.**
- **Do not use the product at a place subject to lots of industrial oil fumes or metal particulates.**
Doing so can cause fire or product failure.
- **Do not use the product at a place subject to leakage or probable leakage of combustible gases.**
It may result in fire or explosion.
- **Do not disassemble the battery.**
There is a risk of fire or electric shock.
- **Do not expose product to heat or fire. Do not expose product direct sunlight.**
There is a risk of fire and explosion.
- **Do not physically impact the battery.**
There is a risk of fire and explosion.
- **Charge only as specified charger. (Genuine adapter included in the product box) Do not use the provided adapter with any other products or for any other purpose than its intended use.**
Please charge the right way.
The battery may be damaged and may cause a fire.
- **If any liquid leaks from the batteries, avoid contact with the skin or eyes. If you touched the liquid, wash contact area with plenty of water and get medical attention.**
There is a risk of burns and blindness.

IMPORTANT SAFETY INSTRUCTIONS

CAUTION

- **Do not use this cleaner on anything other than rated voltage.**
It may cause fire and unreparable product damage.
- **If the product is not in use for a long period of time, pull out the power plug.**
- **Static Electricity may be generated at main body during the cleaning.**
Cleaner may malfunction due to electrostatic energy, so pull out the power cord and put it back in again.
- **Big objects such as socks, stocking, tissues, etc., may block the inlet during the cleaning, so please remove them before starting the cleaning.**
This appliance must be used to remove dust only.
- **Do not stop on one spot or use it on the same spot repeatedly for a long time.**
The surface may be damaged by the friction and vibration.
- **Do not touch the bottom surface with hand or foot while the appliance is in operation.**
- **Do not operate the appliance without the dust bin and its covers in place. Always ensure the dust bin is cleaned when it reaches its limit or beforehand.**
If it is used continuously while dust bin is full, it will cause malfunction and overheating.
- **To avoid the risk of fire or electric shock, always grip it from the plug when removing. And never pull on the power cord when removing it from the wall socket.**
- **If a foreign object is attached to the bottom surface of dust bin, remove it before using the product.**
It could compromise the suction motor and cause malfunction and damage.
- **Never use the product for removing toxic gases.**
The product may fail, and toxic gases will not be removed.
- **Use or place the unit on a level surface and area and do not apply undue force to the unit when using it.**
Doing so can cause fire or product failure.
- **If disposing the unit, it must be done correctly as it contains battery cells that can cause fire or explode if not disposed of correctly.**

元件與功能

Components and functions

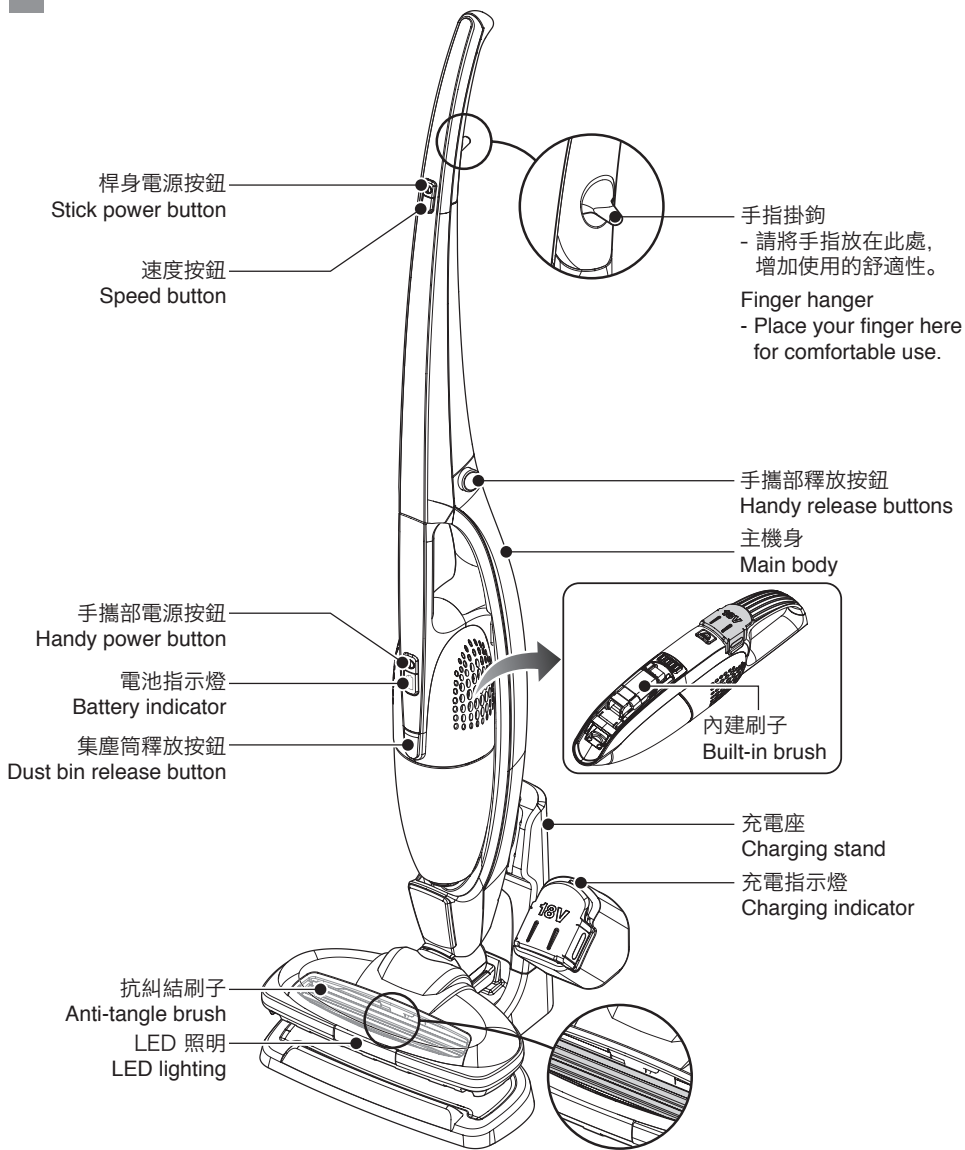

元件： 充電器、把手固定螺絲、
備用電池

Components: Charger, Handle
holding screw, Spare battery



使用方法 組裝真空吸塵器

How to use Assembling vacuum cleaner

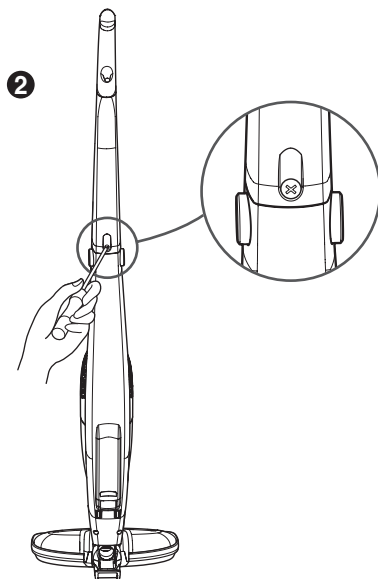
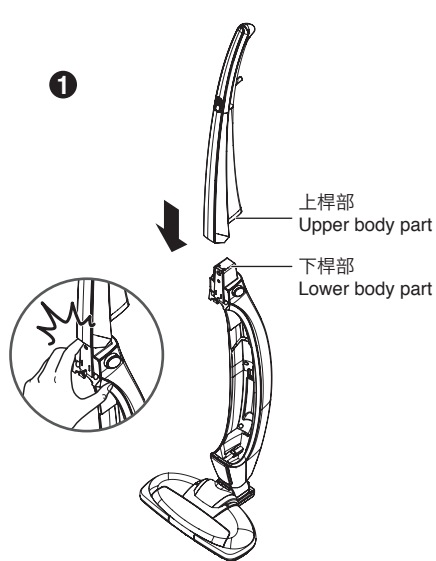

1 將手攜吸塵器裝到桿身 Assembling the Upper and Lower body parts

依照圖中所示的箭頭方向將上桿部連接到下桿部
(在組裝本產品時，請確定勿讓您的手指卡住)。

Attach upper body part to the lower body part in
arrow direction as shown in the figure.
(When assembling the product, make sure not to get
your finger stuck.)

2 鎖上固定螺絲 Fasten the fixing screw

本產品後側有一個固定孔。
使用本產品隨附的固定螺絲來組裝上與
下桿部。

There is a fixing hole on the rear side
the product.
Use the fixing screw provided with the
product to assemble and secure upper
and lower parts.

使用方法 組裝充電器

How to use Assembling Charger

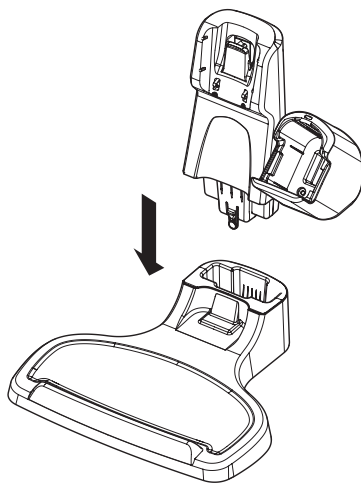

將充電座的上部插入底座直到聽見「咔嗒」聲。

Insert the upper part of the charging stand to the base until you hear a “click” sound.

使用方法 使用本產品

How to use Using the Product

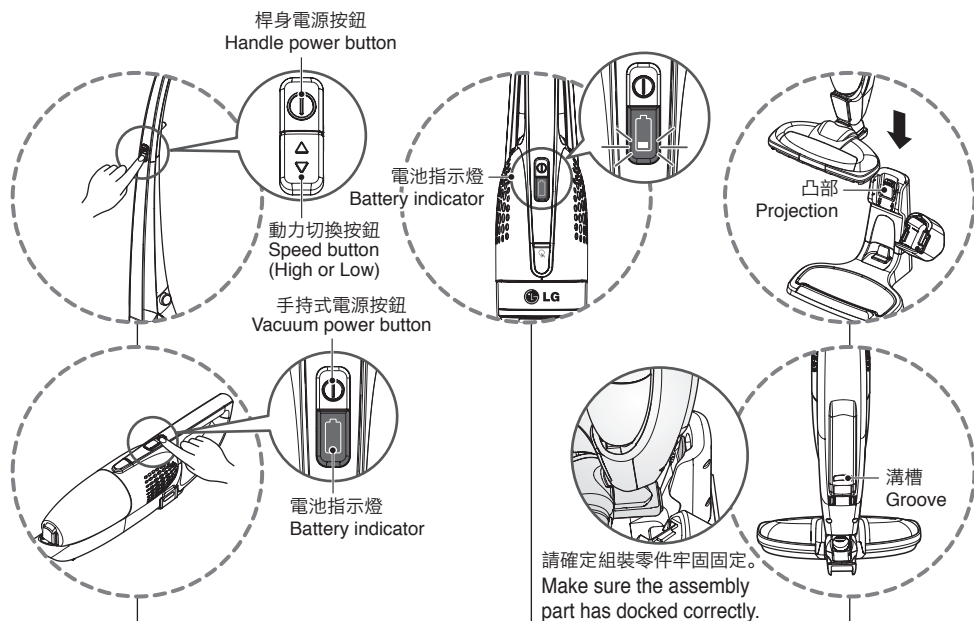

按電源按鈕以啟動本產品。

- 在使用桿式吸塵器時，請用速度按鈕來調整吸塵器速度。
- 在使用直立式吸塵器時，請用動力切換按鈕來調整吸塵器強弱。

Press the power button to turn on the product.

- When you use the vacuum cleaner, select the motor speed with the speed button.
- If the product doesn't work, check the battery indicator for a visual display.

將主機身後側底部如圖片上所示置於充電器上。
請確定主機身牢固固定。

Place the rear bottom of the main body on the charger as shown on the figure.
Make sure the assembly part has docked correctly.

電池指示燈會顯示剩餘電量。

- 完全充電的電池在高速時可持續 20 分鐘，而在中速時可持續 30 分鐘。
- 當電池電量低時，電池指示燈會顯示一個閃爍燈，接著電源很快就會關閉。

Battery indicator shows remaining charge.

- A fully charged battery lasts for 20 minutes at the high speed and for 30 minutes at the normal speed (depending on the floor type).
- When the battery power level is low, the battery indicator shows one blinking light, and then the power turns off soon after.

警告

不能進行液體吸取。
液體吸取可造成故障。

WARNING

Do not use this cleaner to vacuum liquids.
Vacuuming liquids will cause the unit to malfunction.

使用方法 使用本產品

How to use Using the Product



抗糾結刷子適合用於清潔短毛地毯或正常地板表面。

- ① 不建議將吸塵器使用於長毛地毯上。
- ② 若將吸塵器長時間使用於長毛毯上，則可能會造成抗糾結刷子停止運作。
 - 當抗糾結刷子因為馬達過載而停止運作時，請將真空吸塵器關閉然後開啟以讓其再度運作。
- ③ 當您在使用吸塵器期間必須離開現場時，請將真空吸塵器置於地板或充電座上。
 - 當本產品翻倒時，可能會傷及兒童或寵物。

The anti-tangle brush is ideal for cleaning short-furred carpet or a normal timber floor surface.

- ① It is not recommended to vacuum a carpet with long fur.
- ② If you vacuum a long piled carpet, it may cause the anti-tangle brush to stop rotating.
 - When the anti-tangle brush stops due to a motor overload, turn the vacuum cleaner off and on again to allow it to work again.
- ③ After you have finished using the vacuum, place the vacuum cleaner on the floor or on the charging stand.
 - If the product falls over due to improper placement when not in use, it may damage the unit or harm children or pets.

針對抗糾結刷子馬達過載保護的馬達過載保護是為了保護兒童或者在刷子跟紗線或布料糾結時自動停止馬達。

The Anti-hair brush motor is fitted with overload protection which stops the motor from rotating, to help prevent accidental injury or damage to tangled threads and fabrics.

使用方法 使用本產品

How to use Using the Product

為了使用者方便起見，內建刷子是內建在手持式吸塵器上。
在單獨使用手持式吸塵器時，請參閱下列指示。

For the convenience of the user, a built-in brush is attached to the hand held cleaner.
When using the hand held cleaner alone, refer to the following instructions.

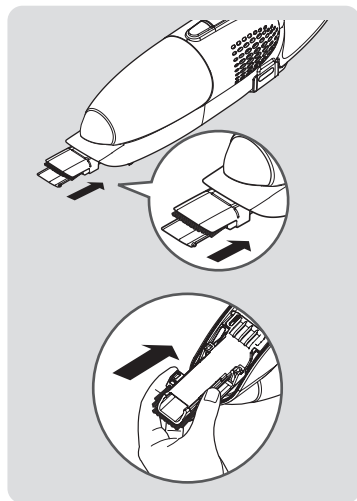
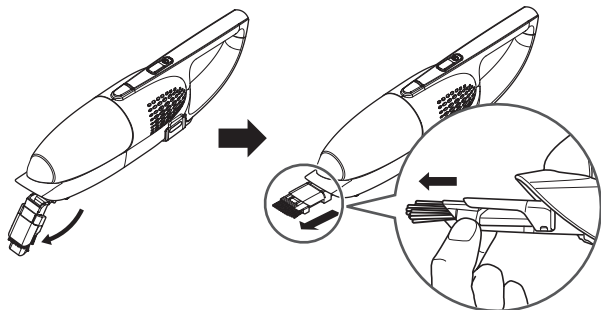

使用內建刷子 Using built-in brush

依箭頭方向拉出位於真空吸塵器底部的內建刷子。

依箭頭方向移動刷子直到其鉤住並固定。

Pull out the built-in brush until it secures into place at the bottom of the vacuum cleaner in the arrow direction.

Move the brush in the arrow direction until it is locked into place.

重新裝回內建刷子。 Retracting the built-in brush

依箭頭方向移動內建刷子的刷子。

依箭頭方向將內建刷子放回外殼內。

Firmly slide the built-in brush in the arrow direction.

Fold the built-in brush body back into the enclosure in the arrow direction.

使用方法 充電

How to use Charging

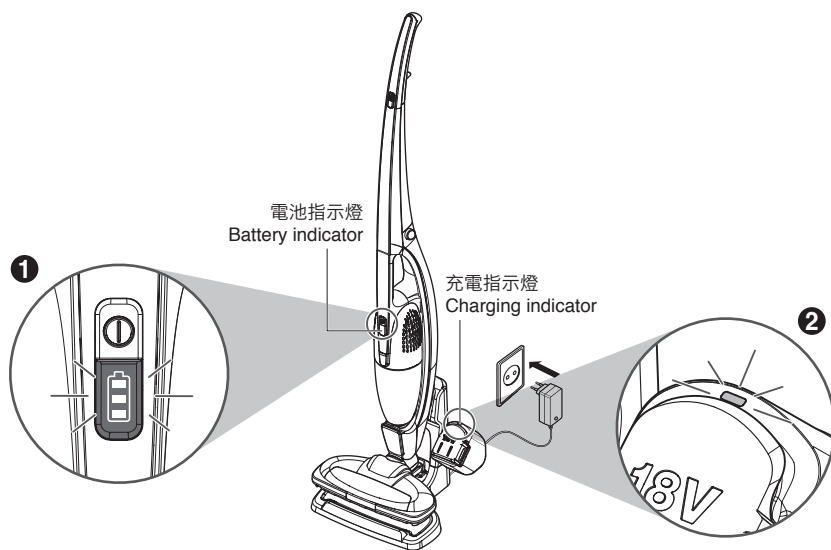

- 1 若使用時電壓過低，電源會自動關閉以保護電池。
接著您必須對電池再充電。在開始再充電之前，請檢查手攜吸塵器是否穩固固定到主機身上，接著將其置於充電座上。

1 If the voltage gets low during operation, the power is automatically turned off to protect the battery.
You must then recharge the battery.
Before beginning the recharge, check that the hand held cleaner is properly docked to the main body, and then place it on the charging stand.
- 2 充電時間可能會視電池狀況而有變化。
在剩下最少的電量時，需要約 4.5 小時以完全充飽電池。(充電一個電池)

 - 真空吸塵器的電池會先充電，接著再讓充電座的電池充電。
 - 在手持式吸塵器充電時，電池指示燈會閃爍以顯示充電量。
 - 在電池完全充飽時，指示燈會保持亮起。
 - 在充電座充電時，電池指示燈會閃爍，而在在電池完全充飽時，指示燈會保持亮起。
 - 在充電結束時，請將插頭從牆壁插座上拔下。
 - 若要使兩個電量耗盡的電池充飽電，可能需要多達 9 個小時。

2 The charging time may vary depending on the battery condition.
When the minimum amount of charge is left, it takes about 4.5 hours to fully charge the battery. (Charging one battery)

 - The battery fitted to the vacuum cleaner is charged first, and then the battery attached to the charging stand is charged.
 - While the hand held cleaner is charging, the battery indicator light blinks to show the charge amount.
 - When the battery is fully charged, the hand held battery status indicator stays on.
 - While the battery on the charging stand is charging, the single LED indicator on the charging stand will blink, and when the battery is fully charged, the LED will remain on.
 - If the vacuum is not used for a long period of time, it is recommended to remove the charging adaptor plug from the wall socket.
 - To get a full charge for the two discharged batteries at the same time, it may take up to 9 hours.

使用方法 清潔集塵筒

How to use Cleaning Dust bin

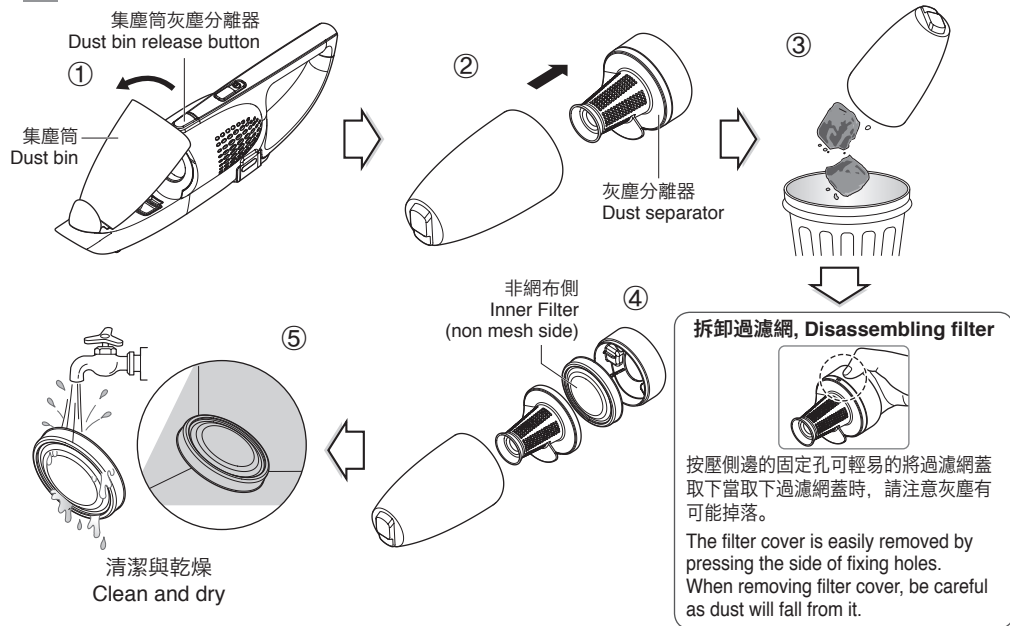

- ① 若要拆下集塵筒，請按住釋放按鈕然後依箭頭方向拉出它。
 - ② 依箭頭方向拆下集塵筒，清空集塵筒。
 - ③ 清空塵箱。
 - ④ 拆卸灰塵分離器以清潔過濾器
(請留意過程中灰塵可能會從過濾器上掉出)。
 - ⑤ 在水中沖洗拆下的過濾器直到流過的水變清澈然後完全陰乾(請勿使用熱水或清潔劑)。
- ① To detach the dust bin, push and hold the release button and pull it in arrow direction.
 - ② Detach the dust separator in arrow direction.
 - ③ Empty the dust bin.
 - ④ Disassemble the dust separator to clean the filter.
(Beware that the dust that may fall off the filter in the process.)
 - ⑤ Rinse the detached filter under water until the water runs clear and completely dry the filter in the shade.
(Do not use hot water or detergent. They may cause deformation to the filter.)

使用提示, Helpful tip

- 為了維護真空吸塵器，請每周用清潔刷或真空吸塵器清理過濾器一次，並且每個月用水清洗至少兩次（經常清理過濾器有助於維持其性能）。
- 若要維持真空吸塵器的最佳性能，請在每次使用後均清空集塵筒。
- 在清潔灰塵分離器後，請確定將其放回集塵筒。
- 請務必在灰塵分離器裝好時才使用真空吸塵器。若未裝好，灰塵將會被吸入主機身內，造成真空吸塵器損壞。
- To maintain the vacuum cleaner, clean the filter once a week with a cleaning brush or by using another vacuum cleaner, and at least twice a month with water. (Frequent cleaning of the filter can help maintain its performance.)
- To maintain the best performance of your vacuum cleaner, empty the dust bin after every use.
- After cleaning the dust separator, be sure to put it back into the dust bin.
- Always use the vacuum cleaner with the dust separator assembled. If not, dust will be sucked into the main body and motor, causing a malfunction and damage to the vacuum cleaner.

使用方法 組裝集塵筒

How to use Assembling Dust bin



- ① 將內部過濾器裝回過濾器外蓋上。
- ② 將灰塵分離器裝回過濾器外蓋上。
- ③ 將灰塵分離器放回集塵筒中。

- ① Attach the inner filter back onto the filter cover.
- ② Attach the dust separator back onto the filter cover.
- ③ Put the dust separator back into the dust bin.

使用提示, Helpful tip

- 參閱下列圖片藉由在右側方向對齊以組裝過濾器外蓋、過濾器支架與集塵筒。
- Refer to the following figure to assemble the filter cover, filter holder and dust bin by aligning in the right direction.

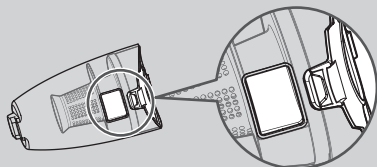

使用方法 清潔吸嘴

How to use Cleaning Nozzle

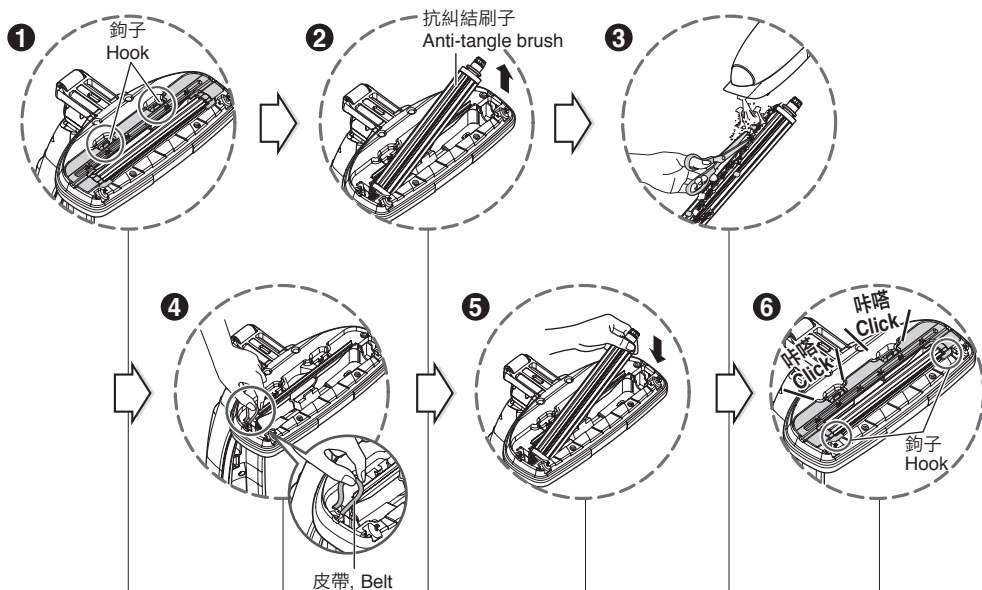

❶ 如圖中所示，按壓鉤子以釋放抗糾結刷子外蓋。

❶ As showing in the figure, press the hook to release the anti-tangle brush cover.

❷ 依箭頭方向拉起抗糾結刷子。

❷ Lift the anti-tangle brush in the arrow direction and detach it from the drive belt.

❸ 使用真空吸塵器來清除抗糾結刷子上的毛髮和紗線。
使用剪刀來剪斷刷子滾筒周圍收集到的毛髮、紗線等
(請勿用水清洗刷子)。

❸ Clean the brush when brush is tangled with hairs and threads.
- Use another vacuum cleaner to remove the hair and threads from the anti-tangle brush.
- Use a pair of scissors to cut the hairs, threads etc. that have collected around the brush.
(Do not use water to clean the brush.)

❹ 將抗糾結刷子放到真空吸塵器內的皮帶中。

❹ Put the anti-tangle brush back onto the belt inside the vacuum nozzle.

❺ 將刷子固定到真空吸塵器中。

❺ Secure the brush into the vacuum nozzle.

❻ 推動刷子外蓋直到聽見「咔嗒」聲。

❻ Refit the brush cover until you hear a "click" sound.

使用提示

- 在清潔或換新之後，請依拆除方式反向操作將抗糾結刷子正確裝回。
- 在開始清潔前，請檢查吸嘴滾輪與刷子滾筒以查看是否有異物卡在裡面。
- 清除異物以保護地板表面。

Helpful tip

- After cleaning or for replacement, assemble the anti-tangle brush properly in the opposite way of removal.
- Before beginning your cleaning, check the nozzle wheels and brush to see if other foreign objects are stuck in them.
- Remove the objects to protect the floor surface.

疑難排解指南

若本產品出現不正常情況，請在呼叫服務中心或商店之前先檢查下列項目。

若本電器沒有任何故障，則將收取服務費用。

按照使用說明書內的簡單操作可能會解決出現的問題。

檢查	請執行下列操作
無吸入與震動噪音或噪音較弱。	<ul style="list-style-type: none">• 檢查入口或集塵筒是否被異物或碎屑阻塞而減弱吸力。• 將集塵筒與機身分離，然後檢查過濾器是否髒汙。
吸塵器完全無法運作？	<ul style="list-style-type: none">• 檢查開關是否已開啟。• 檢查電池電量是否過低。• 依據本手冊內的指示檢查操作程序是否正確。
吸塵器散發出氣味？	<ul style="list-style-type: none">• 在購買本裝置 3 個月之後，吸塵器可能會散發出某些氣味。若該裝置已使用，則此為正常現象。• 氣味也可能由一段時間未經清理的集塵筒和過濾器內的積塵所造成。在重新使用本電器之前，請徹底清空、清潔並清洗集塵筒和過濾器。
排出熱空氣而且機身發熱？	<ul style="list-style-type: none">• 由出口孔排出的空氣會有點熱，因為其是在冷卻馬達之後排出。這是正常現象。
吸塵器只有震動卻沒有吸入。	<ul style="list-style-type: none">• 由於抽取馬達過熱防護裝置，在 1) 集塵筒已滿、2) 過濾器或入口堵塞、或 3) 長時間使用下，可能出現上述現象。在嘗試操作之前，請讓本裝置休息並冷卻至少 40 分鐘。<ul style="list-style-type: none">- 在再次使用之前，請清潔過濾器和集塵筒。- 若入口堵塞，請移除異物。
變壓器電線故障。	<ul style="list-style-type: none">• 故障的插頭應由合格電工更換。

Troubleshooting Guide

If there is an abnormality in the product, check the following items first before requesting for a service center or calling the store.

A service cost will be charged if the appliance has a user related malfunction, or no malfunction is found.

Following simple actions in the user manual may solve the problem.

CHECK	PLEASE PERFORM THE FOLLOWING ACTIONS
Weak or no suction and vibration noise.	<ul style="list-style-type: none">• Check if inlet or dust bin is blocked by any foreign objects or debris that weaken the suction.• Separate dust bin from the main body, and check if the filters are dirty.
Cleaner is not working at all?	<ul style="list-style-type: none">• Check that the switch is turned on.• Check if battery level is low.• Check if the operation procedure is correct according to the instructions within this manual.
Odor comes out of the cleaner?	<ul style="list-style-type: none">• Some odors are normal when the product is first operated and will diminish within 3 months of normal operation.• Odors can also be caused by old dust in the dust bin and filters that has not been cleaned for some time. Empty, clean and wash the dust bin and filters thoroughly before reusing the appliance.
Hot air comes out, and main body is hot?	<ul style="list-style-type: none">• The air coming out of the outlet holes may be warm because it is coming out after cooling the motor. This is normal.
It only vibrates, and there is no suction.	<ul style="list-style-type: none">• Because of the suction motor overheat prevention device, this may occur when 1) dust bin is full, 2) filter or inlet is blocked, or 3) it is used for a long time. Allow the unit to rest and cool for at least 40 minutes before attempting to operate again.<ul style="list-style-type: none">– Before using it again, clean the filter and dust bin.– If the inlet is blocked, please remove the foreign object.
Adaptor cord is defective	<ul style="list-style-type: none">• The defective plug should be replaced by a qualified electrician.



處置您的舊電器

1. 所有電氣和電子產品均應在政府或當地機構規定的指定收集廠從市政垃圾流中分開處理。
2. 正確處理您的舊電器有助防止對環境和人類健康造成潛在的負面影響。
3. 更多有關處理您的舊電器的資訊，請連絡您市政府辦公室、垃圾處理服務或您購買該產品的商店。



處置廢電池/蓄電池

1. 若您產品的電池/蓄電池上貼有交叉的滑輪垃圾桶標誌，這代表該產品符合歐盟指令 2006/66/CE。
2. 如果電池含 0.0005% 以上的汞、0.002% 以上的鎘和 0.004% 以上的鉛，此標誌可能會合併有汞 (Hg)、鎘 (Cd) 或鉛 (Pb) 的化學符號。
3. 所有電池/蓄電池均應經由政府或當地主管機關規定的指定收集設施處置而與市政垃圾流分開。
4. 正確處置您的舊電池/蓄電池將有助於防止對環境、動物和人類健康造成潛在的不良後果。
5. 若要瞭解更多有關處置您舊電池/蓄電池的詳細資訊，請聯絡您的市政府辦公室、垃圾處置服務或您購買該產品的商店。



Disposal of your old appliance

1. All electrical and electronic products should be disposed of separately from the municipal waste stream via designated collection facilities appointed by the government or the local authorities.
2. The correct disposal of your old appliance will help prevent potential negative consequences for the environment and human health.
3. For more detailed information about disposal of your old appliance, please contact your city office, waste disposal service or the shop where you purchased the product.



Disposal of waste batteries/accumulators

1. When this crossed-out wheeled bin symbol is attached to batteries/accumulators of Your product it means they are covered by European Directive 2006/66/CE.
2. This symbol may be combined with chemical symbols for mercury (Hg), cadmium (Cd) or lead (Pb) if the battery Contains more that 0.0005% of mercury, 0.002% of cadmium or 0.004% of lead.
3. All batteries/accumulators should be disposed separately from the municipal waste stream via designated collection facilities appointed by the government or the local authorities.
4. The correct disposal of Your old batteries/accumulators will help to prevent potential negative consequences for the environment, animal and human health.
5. For more detailed information about disposal of Your old batteries/accumulators, please contact Your city office, waste disposal service or the shop where You purchased the product.

注意

Note



