

REFRIGERATOR SERVICE MANUAL

CAUTION

BEFORE SERVICING THE UNIT, READ THE SAFETY PRECAUTIONS IN THIS MANUAL.

**MODEL: LHFS28XBS* /00 LHFS28XBS* /02
LHFS28XBS* /01**

Any reproduction, duplication, distribution (including by way of email, facsimile or other electronic means), publication, modification, copying or transmission of this Service Manual is STRICTLY PROHIBITED unless you have obtained the prior written consent of the LG Electronics entity from which you received this Service Manual.
The material covered by this prohibition includes, without limitation, any text, graphics or logos in this Service Manual.



Contents

Safety Warning and Cautions	3~5
Specifications	6
Parts Identification	7
Disassembly	8~18
Removing Refrigerator Door	8
Door	9
Sub PCB For Working Dispenser	10
Door Alignment	11
Fan and Fan Motor(Evaporator)	11
Defrost Control Assembly	12
Lamp	12
Main PWB	13
Cap Duct Motor Replacement.....	13
How to Remove and Reinstall the Pullout Drawer	14~15
Water Valve Disassembly Method	16
Fan Motor Assembly and Disassembly Method	16
Drawer Removal	17
How to Remove and Refit the Fridge Shelf.....	17
How to Remove the Vegetable Drawer.....	18
How to Remove the Door Basket.....	18
Adjustment	19
Compressor	19
Circuit Diagram	20
Troubleshooting	21~22
PCB Picture	23~24
Trouble Shooting	25~68
Reference	69~72
Component Testing Information	73~79
Compressor Troubleshooting	80~90
Icemaker Operating Method and Trouble Shooting	91~94
Ice Maker(Freezer Room) Operating Method and Trouble Shoot	95~97
Exploded view & Replacement Parts list	98~104



Safety Warning and Cautions

- ▶ 'Cautions for safety' should be observed since they are for previously prevent accidents and dangers when properly use or repair products in a safe manner.
- ▶ Cautions are classified into 'Warning 'and 'Caution ' and meaning of them are as follows

WARNING

Warning means symbol to inform any accidents that may result in large danger such as death or severe injury,etc when violating instructions.

- **Be cautions of air ventilation in case of repairing refrigerator cycle.**
Remove heat source or fire appliance for working since R600a refrigerant is inflammable. (Absolute no-smoking)
- **Be cautious of electric shock.**
Control board uses power supply of about 310V. During the replacement of PWB parts,make sure to pull out the power plug and wait for at least 3 min.,and first pull out the power plug before replacing or repairing other electric parts.
- **Check that power plugs are not pressed by the rear side of refrigerator.**
Damage of power plugs could result in fire or electric shock.
- **If grounding is required,be sure to perform grounding.**
Be sure to perform grounding if deemed there is danger of electric shock by water or moisture.
- **Firstly take power socket out for replacement of indoor lamp.**
Electric shock may occur.
- **Check that dusts are adhered to the power socket and securely insert plugs by the end of pin so that shaking may not occur.**
Dust or incomplete connection may result in fire.
- **When dusts etc are stained to the pin part of the power socket,cleanly wipe out them.**
Fire may occur.
- **Do not expand or modify length of power plugs to use.**
Electric shock or fire may occur due to electrical damage of power cables.
- **Do not touch a refrigerator or socket when gas leaks and open the door for ventilation.**
There is danger of burning due to explosion and sparking.
- **Do not spray water inside or outside of the refrigerator.**
Bad insulation of electrical part may result in electric shock or fire.



Safety Warning and Cautions

⚠ CAUTION

Caution means symbol to inform any accidents that may result in injury or physical damage of houses or furniture, etc when violating instructions.

- **Be sure to rated parts for replacement of electric parts.**
Check marking of model, rated voltage, rated current, operation temperature, etc of electrical parts.
- **Accurately arrange wiring of the housing part for failure repair.**
Check that the hanging part of the housing part is firmly suspended.
- **Do not damage, process or forcibly bend, take out or twist power cords.**
Damage of power cords may cause fire or electric shock.
- **Entirely remove dusts or foreign materials from housing part, wiring part and checking part, etc for failure repair.**
Danger of fire can be prevented from tracking, short, etc.
- **Check assembling status of parts after failure repair.**
Parts should show same status before repair.
- **Check that there is a track that moisture is penetrated into electric parts.**
If there is a track that moisture is penetrated, replace parts or take a necessary step such as insulation tapping.
- **Insert power plug into a socket after more than 3 minutes pass when taking out plugs and then inserting them again.**
Unreasonable operation of a compressor may cause failure.
- **While you pull out the power plugs, hold the end of the plug, not the cord.**
Fire may occur due to electric shock or short-circuit.
- **Do not use power cords or power plugs when they are damaged or holes of power plugs are loose.**
Fire may occur due to electric shock or short-circuit.
- **Install the product at the place where the floor is strong and horizontal.**
If installing the product at unstable place, the refrigerator may upset due to closing or opening of doors of refrigerator and user may be damaged.
- **Do not install product at a place with much moisture and where water spatters.**
Deterioration of insulation may cause electrical leakage.



Safety Warning and Cautions

- **Transport product catching with handles on the bottom side and the top side when transporting.**

If not catching with handles, you can be damaged since the hands are slipped.

- **Do not touch foods or vessels (made of metal) in the freezing room with the wet hands. You may be frostbitten.**

- **Be careful when opening or closing refrigerator door since a person near the refrigerator may be injured.**

Be cautious since the hands or feet are lay between door gaps and children beside the doors may be damaged by the corners of product.

- **Do not put the hands under the bottom of the refrigerator.**

The bottom side of the refrigerator is made of iron plate and so you may be damaged.



Specifications

LHFS28XBS* /00, LHFS28XBS* /01, LHFS28XBS* /02

■ 27.9 cu.ft.

ITEMS	SPECIFICATIONS	ITEMS	SPECIFICATIONS
Door design	Side Rounded	Insulation	Polyurethane Foam
Dimensions (inches)	35 ³ / ₄ × 36 ¹ / ₄ × 69 ³ / ₄ (W×D×H)	Vegetable tray	Clear Drawer Type
Net weight (pounds)	130 kg (287 lb)	Compressor	Linear Inverter
Cooling system	Fan Cooling	Evaporator	Fin Tube Type
Temperature control	Micom Control	Condenser	MC U Condenser
Defrosting system	Full Automatic Heater Defrost	Refrigerant	R600a (55 g)
Door finish	PCM, Stainless	Lubricating oil	ISO10 (280 ml)
Handle type	Bar	Defrosting device	Sheath Heater
Inner case	ABS Resin	Lamp	Refrigerator LED Module
			Freezer LED

■ Dimensions

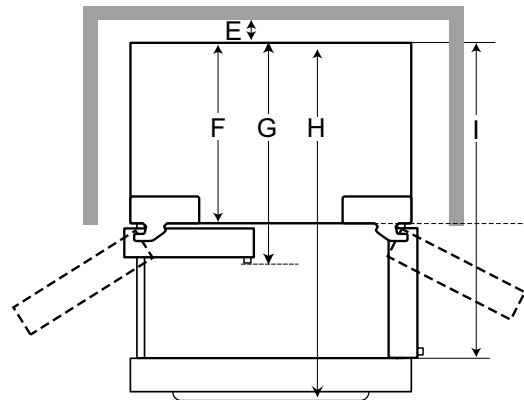
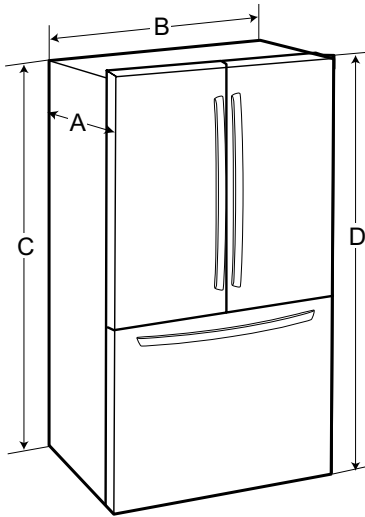

-	Dimension/Clearance	LHFS28XBS*	LFXS26973* LFXS26566*	LFXC22526* LRMXC2206* LMXC22626*
A	Depth without Handle	33 3/4" (857 mm)	32 3/8" (822 mm)	28 3/4" (728 mm)
B	Width	35 3/4" (908 mm)	35 3/4" (908 mm)	35 3/4" (908 mm)
C	Height to Top of Case	68 1/2" (1737 mm)	68 1/2" (1737 mm)	68 1/2" (1737 mm)
D	Height to Top of Hinge	69 3/4" (1772 mm)	69 3/4" (1772 mm)	69 3/4" (1772 mm)
E	Back Clearance	2" (50 mm)	2" (50 mm)	2" (50 mm)
F	Depth without Door	29 7/8" (759 mm)	28 1/2" (724 mm)	24 3/4" (628 mm)
G	Depth with Handle	36 1/4" (921 mm)	34 7/8" (886 mm)	31 1/4" (792 mm)
H	Depth (Total with Freezer Drawer Open)	57 5/8" (1461 mm)	56 1/4" (1426 mm)	48 1/2" (1232 mm)
I	Depth (Total with Door Open 90°)	48 5/8" (1234 mm)	47 1/4" (1199 mm)	43 1/2" (1103 mm)



Parts Identification

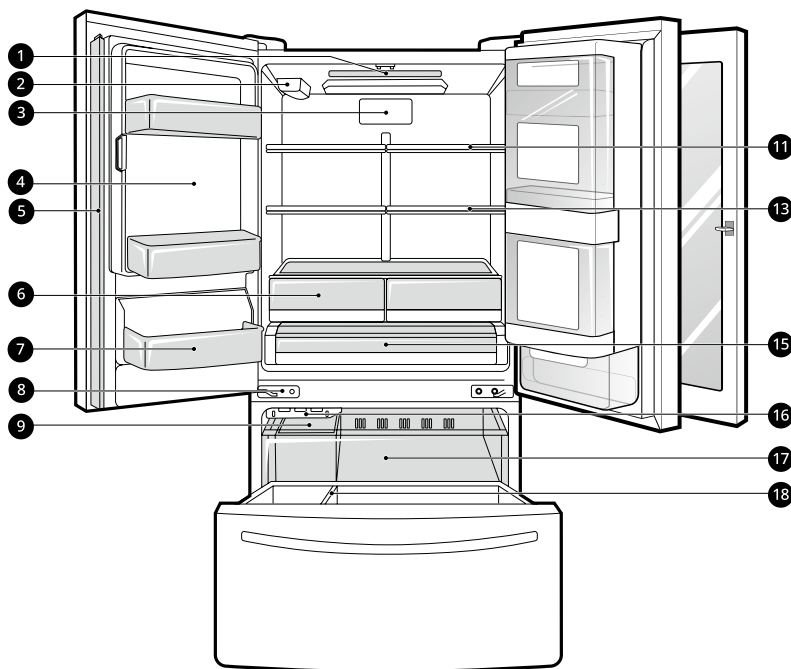

1 LED Interior Lighting

Lights up the inside of the refrigerator.

2 Water filter

Purifies water. The filter should be replaced every 6 months.

3 Air Filter

Reduces odors inside the refrigerator compartment.

4 In-Door Icemaker (Refrigerator)

This is where ice is automatically produced and stored.

5 Door Mullion

Prevents the cold air in the refrigerator from escaping when the doors are closed.

CAUTION

- To reduce the risk of scratching the door or breaking the center door mullion, make sure that the folding door mullion is folded in before closing the left-hand door.
- The door alarm will sound every 30 seconds if the door remains open longer than one minute.

6 Humidity Controlled Crisper

Helps vegetables and fruit to stay crisp and controls humidity.

7 Fixed Door Bin

Stores chilled food or drinks.

8 Auto-Closing Hinge†

The refrigerator doors and freezer drawers close automatically when pushed slightly. (The door only closes automatically when it is open at an angle of less than 30°.)

9 Ice Bin

Stores ice from the freezer icemaker.

10 Door-in-Door Case†

A convenient storage area for frequently-used items that require easy access.

11 Adjustable Refrigerator Shelf

The refrigerator shelves are adjustable to meet individual storage needs.

12 Cheese & Butter and Condiment Bins†

Cheese & Butter and Condiment bins are specially designed for these items, making spreading butter and slicing cheese easier.

13 Folding Shelf†

Store taller items, such as gallon containers or bottles, by pushing the front half of the shelf underneath the back half of the shelf.

14 Modular Door Bin†

Interchangeable bins can be arranged to suit storage needs.

15 Glide'N'Serve

Stores food items at a different temperature than the regular refrigerator area.

16 Automatic Icemaker (Freezer)†

Dispenses ice automatically.

17 Pullout Drawer†

Provides extra storage within the freezer compartment.

18 Durabase and Durabase Divider

Provides storage for large frozen food items.

† This feature is only available on some models.



Disassembly

Removing Refrigerator Door

⚠ CAUTION

Before you begin, unplug the refrigerator. Remove food and bins from doors.

▶ Left Door -FIG. 1&2

1. Open door. Loosen top hinge cover screw (1). Use flat tip screwdriver to pry back hooks on front underside of cover (2). Lift up cover.
2. Disconnect door switch wire harness and remove the cover.
3. Disconnect all wire harnesses (3). Remove the grounding screw (4).
4. Rotate hinge lever (5) counterclockwise. Lift top hinge (6) free of hinge lever latch (7).

⚠ CAUTION

When lifting hinge free from the latch, be careful that door does not fall forward.

5. Lift the left refrigerator door until it is free of the middle hinge assembly and remove door.
6. Place the door with the insides facing up, on a not scratch surface.

▶ Right Door -FIG. 3&4

1. Open the door, Loosen top hinge cover screw (1). Lift up cover (2).
2. Disconnect all wire harnesses (3).
3. Remove the grounding screw (4)
4. Rotate hinge lever (5) clockwise. Lift top hinge (6) free of hinge lever latch (7).

⚠ CAUTION

When lifting hinge free from the latch, be careful that the door does not fall forward.

5. Lift the right refrigerator door until it is free of the middle hinge assembly and remove door.
6. Place the door with the insides facing up, on a not scratch surface.

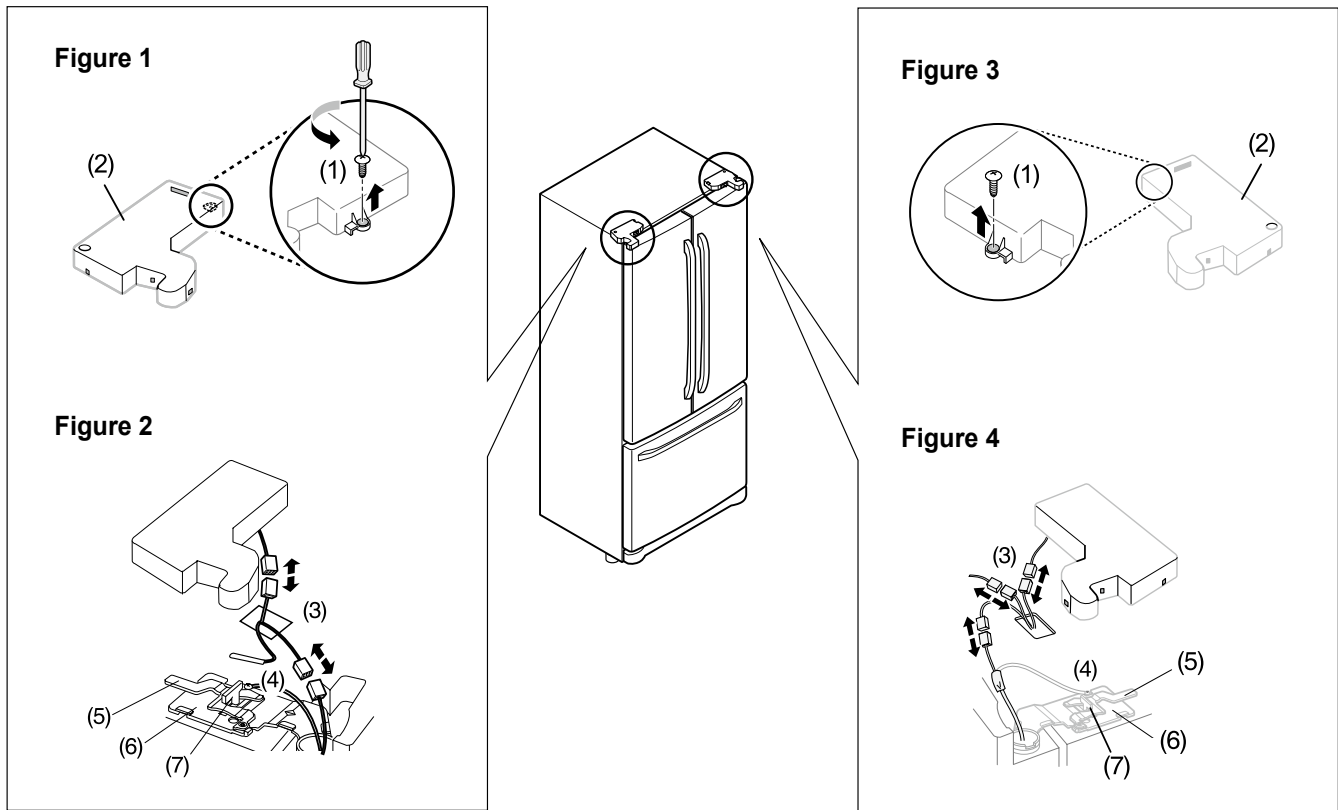



Disassembly

Door

■ Mullion Removal

1. Remove 2 screws.



2. Lift Mullion up carefully.



3. Disconnect wire harness.



■ Door Gasket Removal

1. Remove gasket

Pull gasket free from gasket channel on the four remaining sides of door.

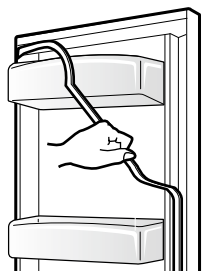

■ Door Gasket Replacement

1. Insert gasket into channel

Press gasket into channels on the four remaining sides of door.

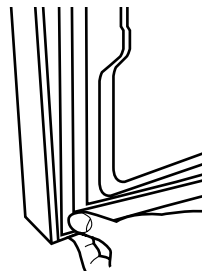

■ Mullion Replacement

1. Connect wire harness.



2. Insert mullion into the channel.

Insert the cover assembly into bracket, door



3. Assemble 2 screws.





Disassembly

Sub PCB For Working Dispenser

Sub, PCB Removal

1. Remove 1 screws.



2. Lift Sub PCB up carefully.

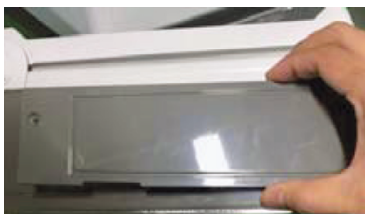

3. Reverse the Sub PCB cover.



4. Disconnect capacitor housing.

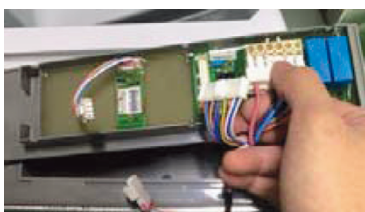

5. Disconnect wire harness.



Sub, PCB Replacement

1. Reverse the Sub PCB cover.

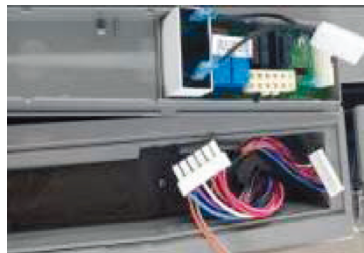

2. Connect wire harness.



3. Connect the capacitor housing.

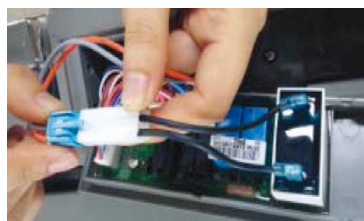

4. Insert the Sub PCB sliding.



5. Assemble 1 screw.





Disassembly

Door Alignment

Both the left and right refrigerator doors have an adjustable nut, located on the bottom hinge, to raise and lower them to align properly.

If the space between the doors is uneven, follow the instructions below to align the doors evenly:

Use the wrench (included with the owner's manual) to turn the nut in the door hinge to adjust the height.

Turn the nut to the right to raise the door or to the left to lower it.

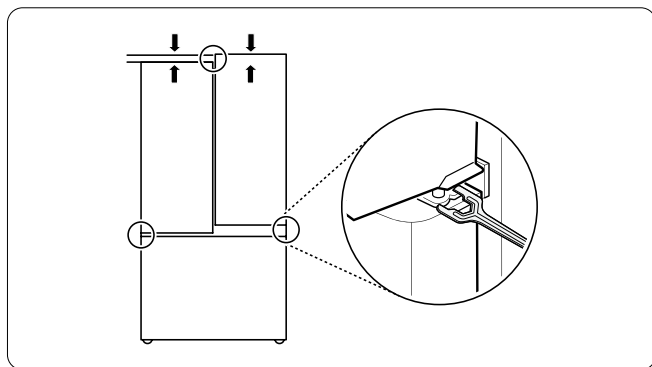

Fan and Fan Motor(Evaporator)

1. Remove the freezer drawer. (If your refrigerator has an icemaker, remove the icemaker first)
2. Remove the plastic guide for slides on left side by unscrewing phillips head screws.
3. Remove the grille by removing 4 screws and pulling the grille forward.
4. Remove the Fan Motor assembly by loosening 3 screws

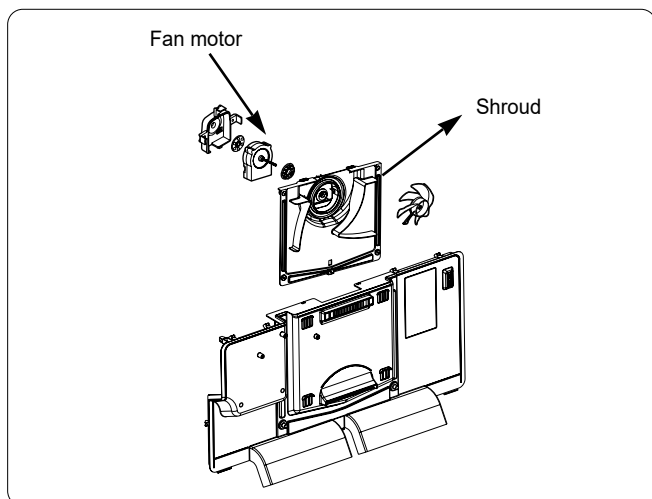

* Ice Fan Assembly Replacement

- 1) Remove the plastic guide on the left side, using a



- 2) Pull off the sensor cover.



- 3) Remove the grill cover.



- 4) Gently pull on the grill assembly to remove.



- 5) Disconnect the wiring harness.



- 6) Remove all screws on the scroll assembly.





Disassembly

Defrost Control Assembly

Defrost Control assembly consists of Defrost Sensor and FUSE-M.

The Defrost Sensor works to defrost automatically. It is attached to the metal side of the Evaporator and senses its temperature. At 46°F(8°C), it turns the Defrost Heater off.

FUSE-M is a safety device for preventing over-heating of the Heater when defrosting.

1. Pull out the grille assembly.
2. Separate the connector with the Defrost Control assembly and replace the Defrost Control assembly after cutting the Tie Wrap.

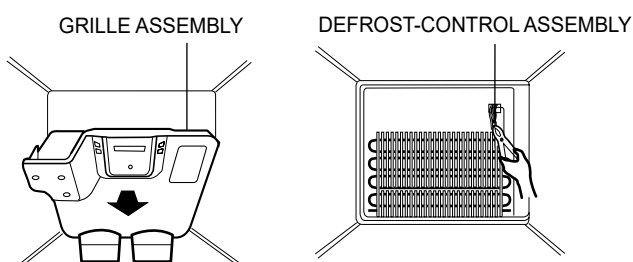

Lamp

Unplug, or disconnect power at the circuit breaker. If necessary, remove top shelf or shelves.

1. Refrigerator Compartment Lamp

- 1) Pull out cover lamp as using sharp-edged tool.



- 2) To remove the LED assembly.

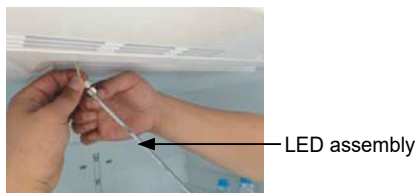

- 3) Decor Duct(Grille) SVC.

Remove the Decor Duct with tools like flat-head screwdriver.



2. Cap Decor LED LAMP(Bottom)

- 1) Unplug refrigerator power cord from electric outlet.
- 2) Open the refrigerator door to need disassembly.
- 3) Put flat screwdriver into service hole, remove the cover of cap decor LED LAMP.



- 4) Remove the LED assembly from connector.



- 5) Replace LED assembly.



- 6) Assembly the cover in reverse order.

3. Multi Duct

- 1) Remove the screw at the Center of Duct Multi.
- 2) Remove the screw and cover filter.
- 3) Disconnect the lead wire on the bottom position.

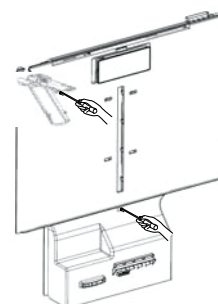



Disassembly

Main PWB

1. Loosen 3 screws on the PWB cover.



2. Remove the PWB cover.



3. Disconnect wire harness and replace the main PWB in the reverse order of removal.



Cap Duct Motor Replacement

1. Separate the Housing of the Cap Duct Motor.



2. Unscrew 3 screws to disassemble the motor.



3. When replacing the motor, check position of the door duct and the link for proper fit.



Duct Door
Link
Cap Duct Motor



NG Position

4. Insert 3 screws.



5. Push housing aside.





Disassembly

How to Remove and Reinstall the Pullout Drawer

1. Follow Steps to Remove

Step 1) Open the freezer door.



Step 2) Remove the lower basket.



Step 3) Remove the two screws from the guide rails.
(one from each side)

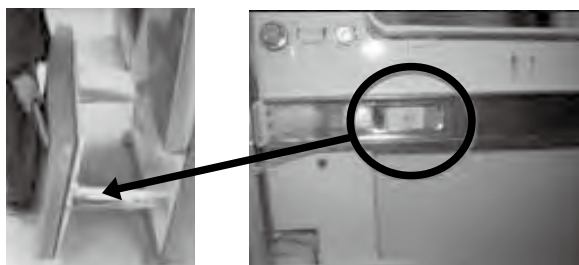

Step 4) Removal of the freezer door is done by lifting clear of the rail support. Fully extend both rails.



Step 5) Remove only 1 screw of gear ice, and disassemble the bar and gear ice.



Step 6) Remove 2 screws of both side of supporter cover TV and disassembly the supporter cover TV.





Disassembly

2. Follow Steps to Reinstall

Step 1) Insert both side of supporter cover TV into connector,rails, and then screw them.



Step 2) ① Assemble a bar and gear ice with screw.
② Push the otherside of the gear to inside of the bar.

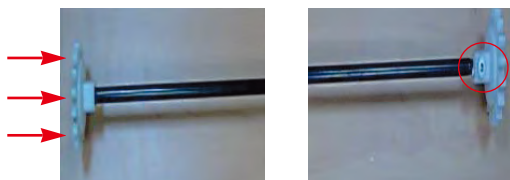

Step 3) Put gear ice assembled with the bar by screw into connector rail's hole.



Step 4) Insert opposite gear ice into connector rail and screw them.



Step 5) The rail system will align itself by pushing the rails all the way into the freezer section. Pull the rails back out to full extension.

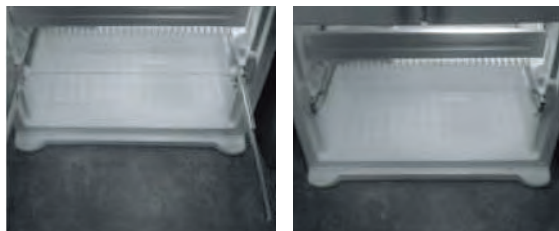

Step 6) Reinstall the freezer door by inserting the rails tabs into the guide rail.

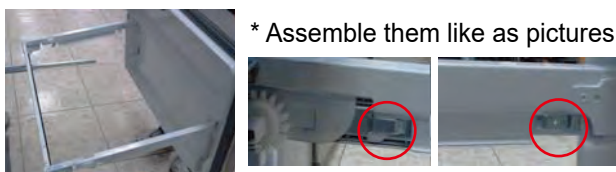

Step 7) Reinstall the two screws into the guide rails. (one from each side)

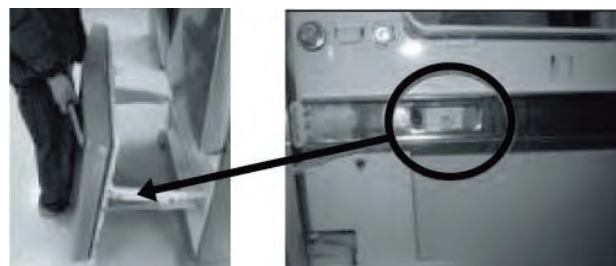

Step 8) Reinstall the lower basket, and close the freezer door.





Disassembly

Water Valve Disassembly Method

1. Turn off the water to unit. Remove the waterline from the valve.

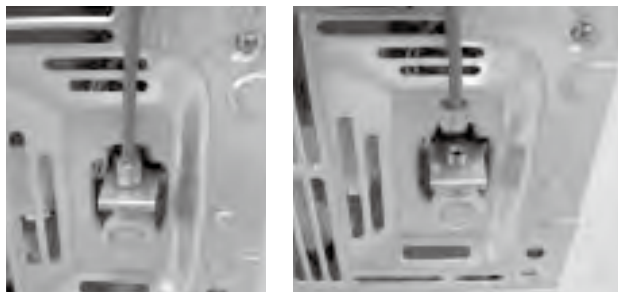

2. Remove cover and 1 screw from the valve.

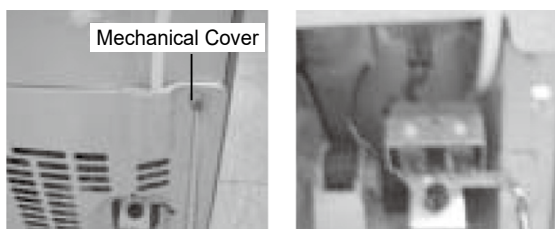

3. Separate the housing and remove the valve.

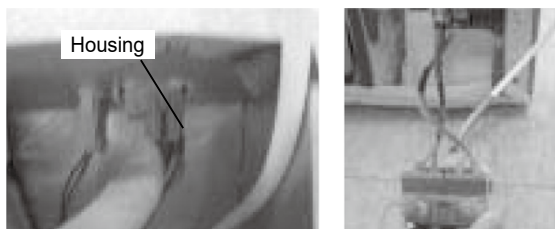

4. Remove the clip, and press the collet to separate the tube from the connector.

NOTE : there maybe some water in the line.

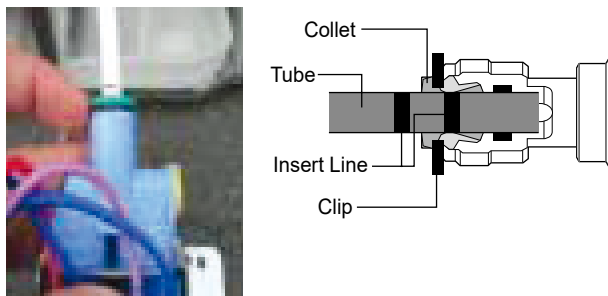

Fan Motor Assembly and Disassembly Method

1. Remove screws for the Drain Pipe Assembly and the 1 connected to the Motor Cover.

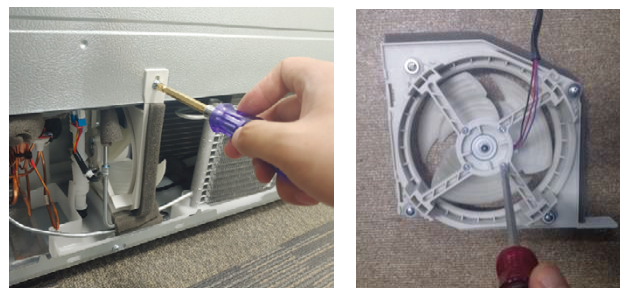

2. Remove the screw from shroud and Separate the Fan motor assembly and Shroud.



Assemble in reverse order. Taking care to avoid.

1. Do not to bend the tube during assembly.
2. Press the Water Dispenser button letting water pour out, this checks for any leaks in the tube connection, this may vary depending on the water pressure (about 2 minutes.).



Disassembly

Drawer Removal

1. Pull the drawer open to full extension.
2. Gently lift and pull out the ice bin.

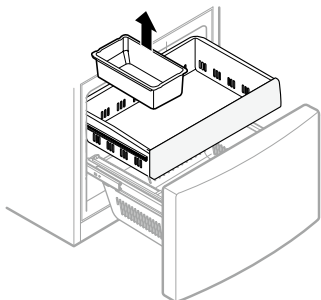

3. Lift the front of the drawer up, then pull it straight out.

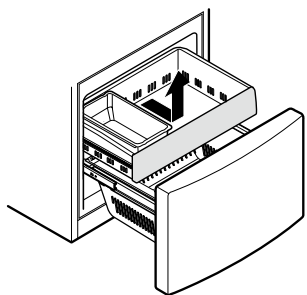

4. Remove the Durebase basket from the rails.
Remove the screws from the rails at both ends.

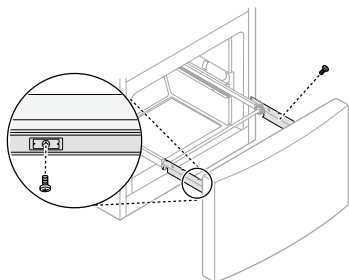

5. Grip both sides of the drawer and pull it up to remove it from the rails.

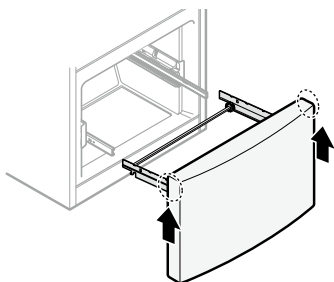

How to Remove and Refit the Fridge Shelf

1. Removing the Fridge Shelf

- 1) Tilt the front of the shelf up and then lift the shelf straight up.
- 2) Lower the front of the shelf so that the hooks into the holes.

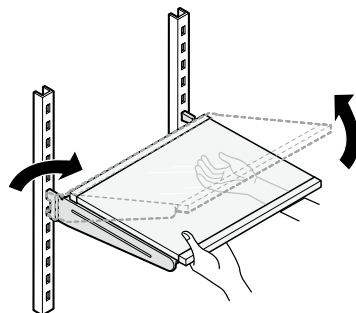

2. Refitting the Fridge Shelf

- 1) Tilt the front of the shelf up and guide the shelf hooks into the holes at the desired height.
- 2) Lower the front of the shelf so that the hooks into the holes.

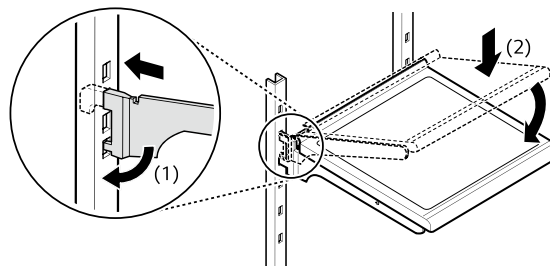



Disassembly

How to Remove the Vegetable Drawer

1. Remove the contents of the drawer.
Hold the handle of the drawer and gently pull it out completely until it stops.

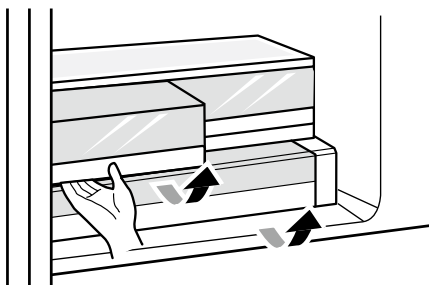

2. Lift the vegetable drawer up and remove it by pulling it out.

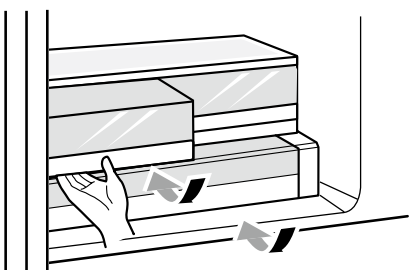

- 3) Repeat to remove the second drawer.
- 4) Tilt the cover slightly and support it with both hands while pulling it out.

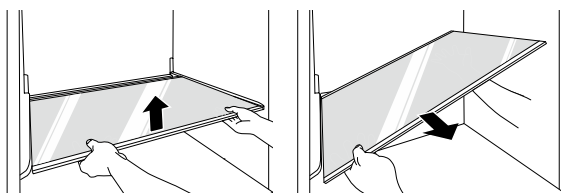

How to Remove the Door Basket

1. To remove the basket, simply lift the bin up and pull straight out.
2. To replace the basket, slide it in above the desired support and push down until it snaps into place.

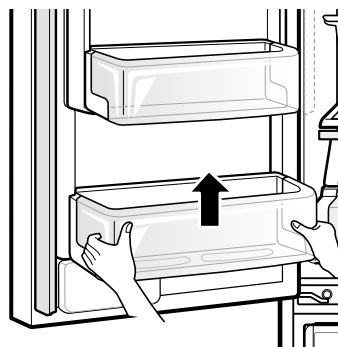



Adjustment

Compressor

1. Role

The compressor intakes low temperature and low pressure gas from the evaporator of the refrigerator and compresses this gas to high-temperature and high-pressure gas. It then delivers the gas to the condenser.

2. Note for Usage

- (1) Be careful not to allow over-voltage and over-current.
- (2) Do not drop or handle carelessly.
- (3) Keep away from any liquid.
If liquid such as oil or water enters the Cover PTC Compressor may fail due to breakdown of their insulating capabilities.
- (4) Always use the Parts designed for the compressor and make sure it is properly attached to the compressor. Parts may appear physically identical but could have different electrical ratings. Replace parts by part number and model number. Use only approved substitute parts.

3. Remove the cover PTC

- (1) Remove the Cover Back M/C



- (2) Loosen two screws on comp base



- (3) Use a L-shaped flap tool to pry off the cover



- (4) Assembly in reverse order of disassembly



Circuit Diagram

MEZ69199307 (Label,Circuit)



MEZ69199307_Rev.00

CIRCUIT DIAGRAM SCHEMA DU CIRCUIT

*EARTH PART, REACTOR PART, F-LAMP, F-ROOM LED MODULE, PLUG TYPE AND COMP EARTH PART, FUSE ON CIRCUIT DIAGRAM ARE SUBJECT TO CHANGE IN DIFFERENT LOCALITIES AND MODEL TYPE.
*PIÈCE DE MISE À LA TERRE, RÉACTEUR PARTIE, LAMPE-AVANT, MODULE LED PIÈCE F, LE TYPE DE PRISE ET DE MISE À LA TERRE DU COMPRESSEUR, ET LES FUSIBLES FIGURANT SUR LE SCHEMA DU CIRCUIT SONT SUJETS À MODIFICATION SELON LES RÉGIONS ET LE TYPE DE MODÈLE.

- I : OPTIONAL / OPTIONNEL

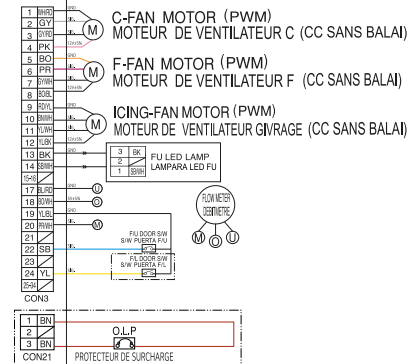
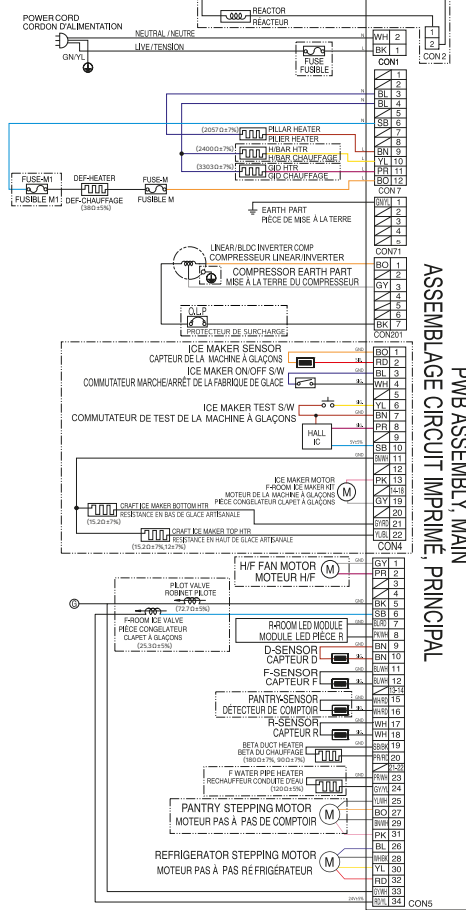

F-SENSOR / CAPTEUR F ICE MAKER SENSOR / CAPTEUR DE LA MACHINE À GLAçons	RESISTANCE / RESISTANCE [Ω]
-22.7 / 30°C	40k±5%
-19.7 / 25°C	30k±5%
-17 / 20°C	23k±5%
-5.7 / 15°C	17k±5%
14.7 / 10°C	13k±5%
23.7 / 5°C	10k±5%
32.7 / 0°C	8k±5%
77.7 / 25°C	2.48k±5%

B-SENSOR / CAPTEUR B D-SENSOR / CAPTEUR D PANTRY-SENSOR / DETECTEUR DE COMPOTIR	RESISTANCE / RESISTANCE [Ω]
23.7 / 5°C	38k±5%
32.7 / 0°C	30k±5%
47.7 / 5°C	24k±5%
50.7 / 10°C	19.5k±5%
59.7 / 15°C	16k±5%
77.7 / 25°C	10.67k±5%

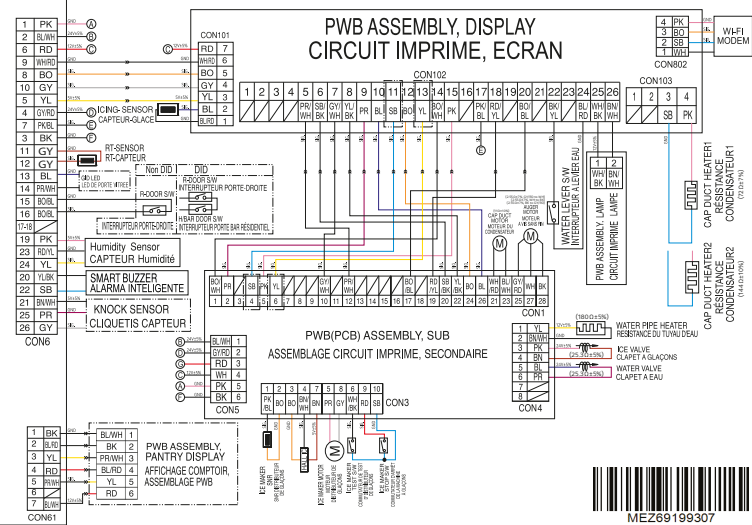

- BK(BLACK) : NOIR BL(BLUE)BLEU BN(BROWN) : MARRON BO(BRIGHT ORANGE) : ORANGE BRILLANT GY(GRAY) : GRIS RD(RED) : ROUGE WH(RD) : BLANC/ROUGE
- YL(YELLOW) : JAUNE GN(GREEN) : VERT PR(PURPLE) : PURPLE WH(WHITE) : BLANC YL(BK)(YELLOW/BLACK) : JAUNE/NOIR PR(WH)(PURPLE/WHITE) : VIOLET/BLANC RD(YL)(RED/YELLOW) : ROUGE/JAUNE
- SB(SKY BLUE) : BLEU/BLANC PK(PINK) : ROSE GNYL(GREEN/YELLOW) : VERT/JAUNE BL(WH)(BLUE/WHITE) : BLEU/BLANC RD(WH)(RED/WHITE) : ROUGE/BLANC GY(WH)(GRAY/WHITE) : GRIS/BLANC BO(BL)(BRIGHT ORANGE/BLUE) : ORANGE BRILLANT/BLEU BO(WH)(BRIGHT ORANGE/WHITE) : ORANGE BRILLANT/BLANC

Automatic Icemaker Water Line Hookup
 Conexión de la Fábrica de Hielo a la tubería de agua
 Raccordement d'une conduite d'eau à la machine à glaçons automatique

For USA
 Para los EE. UU.
 Pour les États-Unis



For Canada
 Para Canada
 Pour le Canada





Troubleshooting

Error Code Summary

Error Code ② Error Code ①



⚠ WARNING

When checking Resistance values, make sure to turn off the power, and wait for the voltage to discharge.

NOTE) Within 3 hours after the error : Press the Ice Plus button and Freezer button simultaneously
3 hours after the error : All errors, except for “rt E”, “HS E”, “IS E”(except for icing sensor), “gF E”, “It E” error, are displayed. “IS E” which is displayed without input of user is the error of Icing Sensor.

NO	Error Detection Category	Error Display		Error Generation Factors	Remark
		Freezer Temperature (Error code ②)	Refrigerator Temperature (Error code ①)		
1	Normal			None	Ration of display
2	Freezer Sensor Error	FS	E	Short or Disconnection of Freezer Sensor	Check each sensor at it's connector.
3	Refrigerator Sensor Error	rS	E	Short or Disconnection of Refrigerator Sensor	
4	Defrosting Sensor Error	dS	F	Short or Disconnection of Defrosting Sensor	
5	Icing Sensor Error	IS	E	Short or Disconnection of the sensor about Ice maker (Icing sensor, Ice maker sensor)	
6	Humidity Sensor Error	HS	E	Short or Disconnection of Freezer Humidity	
7	Room Temp Sensor Error	rt	E	Short or Disconnection of Room temp. sensor	
8	Ice maker kit defect	It	E	Other Electric system error such as Motor, Gear, Hall IC, operation circuit within I/M kit.	
9	Flow Meter(Sensor) Defect	gF	E	Error of flow meter or water input or low water pressure	Error of flow meter or water input or low water pressure or flow meter connection
10	Poor Defrosting	dH	F	During 2 consecutive cycles the defrosting sensor did reach over 46°F (8°C)	Temperature Fuse Disconnection, Heater disconnection, DRAIN Jam, Poor Relay for Heater
11	Abnormality of BLDC FAN Motor for Ice Making	IF	E	It is caused when feedback signal isn't over 65 seconds during BLDC FAN motor operating	Poor BLDC Motor connection, DRIVE IC, and TR
12	Abnormality of BLDC FAN Motor for Freezer	FF	E	It is caused when feedback signal isn't over 65 seconds during BLDC FAN motor operating	Poor BLDC Motor connection, DRIVE IC, and TR



Troubleshooting

NO	Error Detection Category	Error Display		Error Generation Factors	Remark
		Freezer Temperature (Error code ②)	Refrigerator Temperature (Error code ①)		
13	Abnormality of BLDC FAN Motor for Mechanic Room	CF	E	It is caused when feedback signal isn't over 65 seconds during BLDC FAN motor operating	Poor BLDC Motor connection, DRIVE IC, and TR
14	Communication Error (Main PCB ↔ Display PCB)	CO	E	Communication Error between Micom of Main PCB and Display Micom	Poor Communication connection, Poor TR of Transmitter and Receiver Tx/Rx between display and main board.
15	Communication Error (Display PCB ↔ I/Maker Sub PCB)	Sd	E	Communication Error between Micom of Display PCB and I/Maker Sub PCB Micom	Poor Communication connection, Poor TR of Transmitter and Receiver Tx/Rx between display and sub pcb board.
16	Abnormal Pantry Sensor	SS	E	Pantry Sensor Short or Open Circuit	Check sensor at it's connector
17	Abnormal Wi-Fi Modem	Od	E	Communication Error between Display and Wi-Fi Modem	Poor Communication connection (Short or Open Circuit) Poor TR of Transmitter and Receiver Tx/Rx
18	High side cycle leakage	CH	E	Detected by high side refrigerant leak, restriction, bad comp, bad valve, etc.	Refer to 8-21
19	Low side cycle leakage	CH	E	Detected by low side refrigerant leak, bad comp, long time door open, etc.	Refer to 8-21
20	Abnormal F Room Icemaker Tray Sensor	ld	E	Icemaker Tray Sensor Short or Open Circuit	Check sensor at it's connector
21	Abnormal F Room IceMaker Kit	IU	E	Other Electrics System Error Such As Motor, Gear, Hall IC, Operation circuit Within I/M Kit, Upper HTR or Lower HTR on the Icemaker is Open circuit	When the Ice Does not Drop even when the I/M Test S/W is pressed Or check connection or resistance **Diagnosis for Test S/W not working



PCB Picture

Main PCB

(P/No. : EBR860937**)

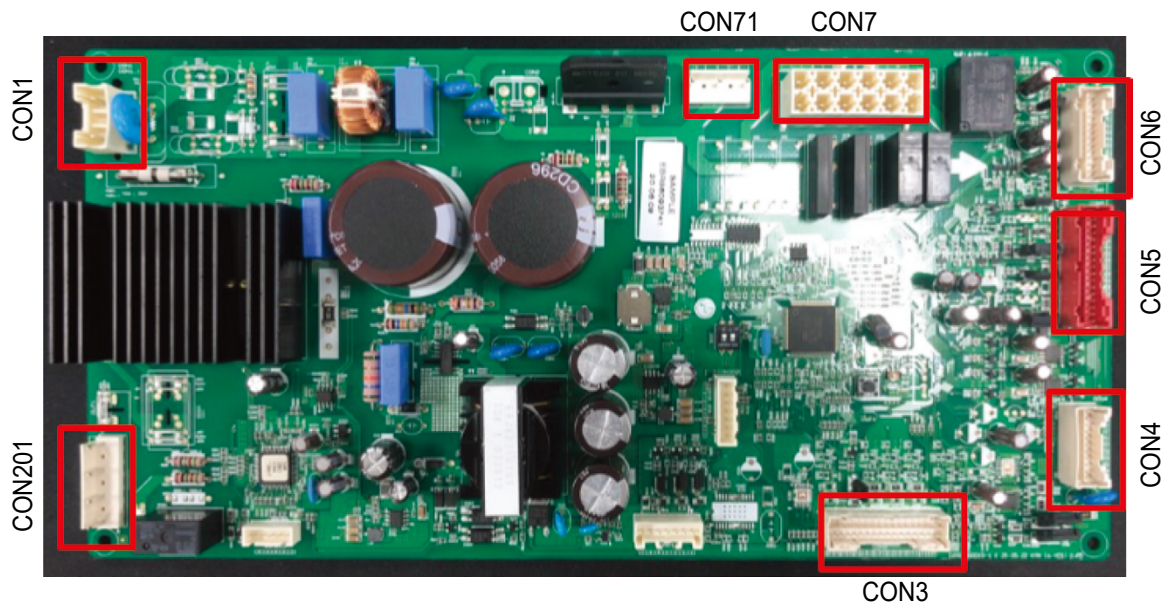

Display PCB

(P/No. : EBR841464**)

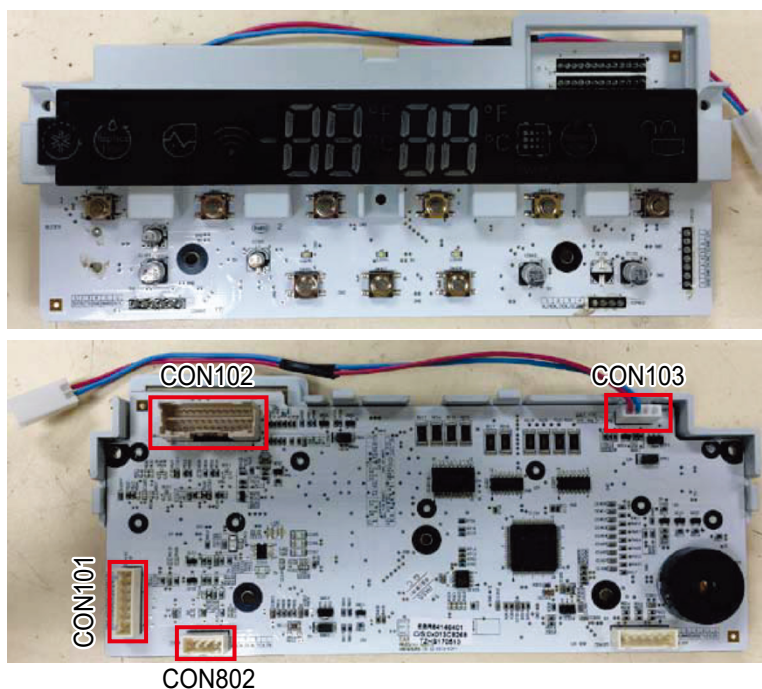



PCB Picture

Sub PCB

(P/No. : EBR881246**)

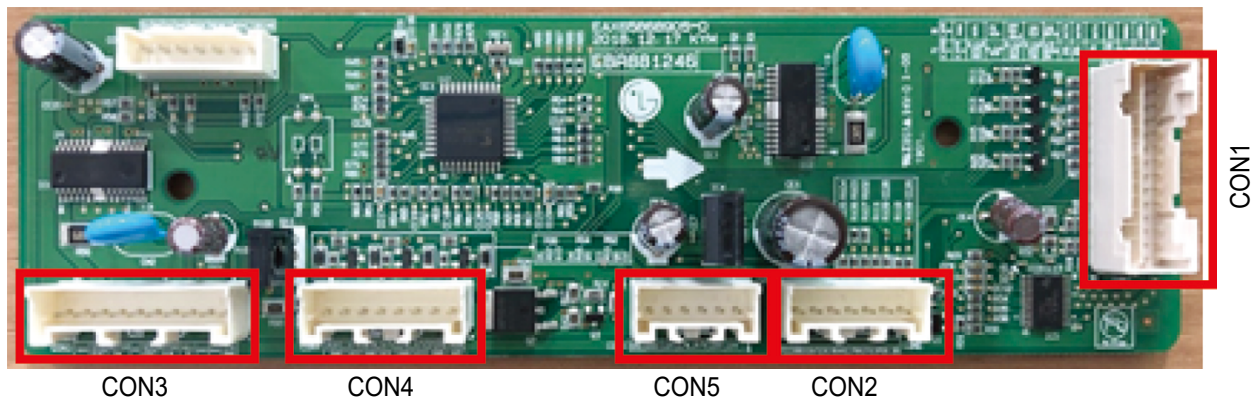



Trouble Shooting

Freezer Sensor Error (FS E)

Symptom	Check Point
1. FS E	1. Check for a loose connection 2. Check Sensor Resistance

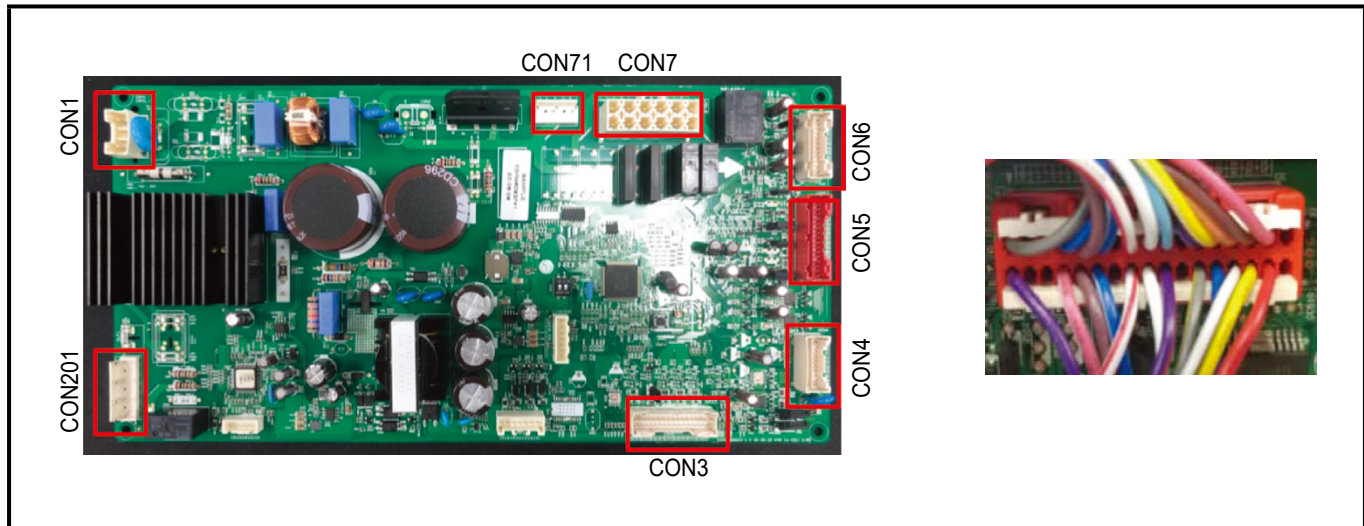

		Resistance [Ω]	
CON5 12 th Pin ~ 11 th Pin	Short	0	
	Open	OFF	
	Other	Normal	

CON5 12 th Pin ~ 11 th Pin	Resistance [Ω]
-22°F / -30°C	40k
-13°F / -25°C	30k
-4°F / -20°C	23k
5°F / -15°C	17k
14°F / -10°C	13k
23°F / -5°C	10k
32°F / 0°C	8k



Trouble Shooting

Freezer Sensor Error (FS E)

1

Is the Connector disconnected or loose between Main PCB and sensor?

Yes → Reconnect or repair the connector

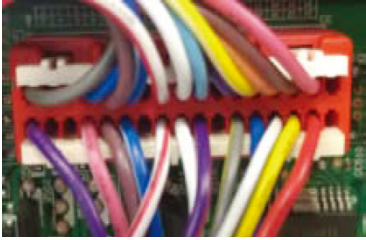

CON5

No →

2

Check the Sensor resistance. Is resistance 0Ω (Sensor short)?

Yes → Change the Sensor

No →

3

Check the Sensor resistance. Is resistance OFF (Sensor open)?

Yes → Replace the refrigerator

No →

4

Check the Sensor resistance. Is resistance normal?

Yes →

5

Check the Temperature and resistance refer to the table. No problem?

No → Change the Sensor

CON5 12 th Pin ~ 11 th Pin	Resistance [Ω]
-22°F / -30°C	40k
-13°F / -25°C	30k
-4°F / -20°C	23k
5°F / -15°C	17k
14°F / -10°C	13k
23°F / -5°C	10k
32°F / 0°C	8k

Yes →

6

Explain to customer



Trouble Shooting

Refrigerator Sensor Error (rS E)

Symptom	Check Point
1. rS E	1. Check for a loose connection 2. Check Sensor Resistance

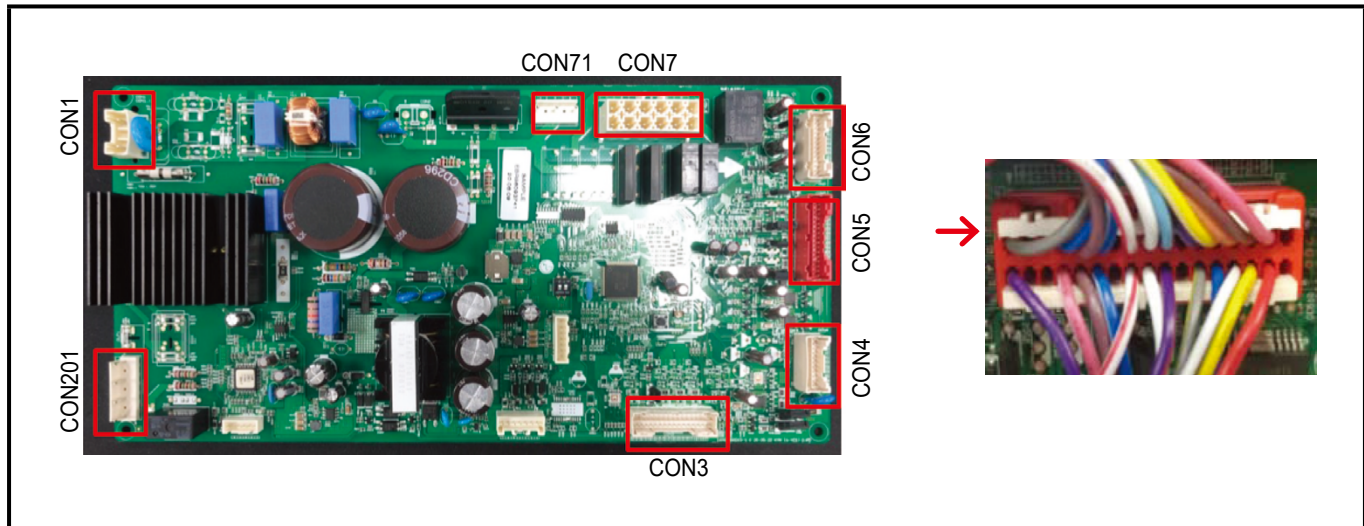

		Resistance [Ω]	
CON5 18 th Pin ~ 17 th pin	Short	0	
	Open	OFF	
	Other	Normal	

CON5 18 th Pin ~ 17 th pin	Resistance [Ω]
23°F / -5°C	38k
32°F / 0°C	30k
41°F / 5°C	24k
50°F / 10°C	19.5k
59°F / 15°C	16k

-ROOM ICE VALVE PIÈCE CONGELATEUR CLAPET À GLAÇONS	R-ROOM LED MODULE MODULE LED PIÈCE R	BLRD 7
	D-SENSOR CAPTEUR D	PKWH 8
	F-SENSOR CAPTEUR F	BN 9
	PANTRY-SENSOR DÉTECTEUR DE COMPTOIR	BN 10
	R-SENSOR CAPTEUR R	BLWH 11
	BETA DUCT HEATER BETA DU CHAUFFAGE	BLWH 12
	F WATER PIPE HEATER RECHAUFFEUR CONDUITE D'EAU	13-14
	PANTRY STEPPING MOTOR MOTEUR PAS À PAS DE COMPTOIR	WHRD 15
	REFRIGERATOR STEPPING MOTOR MOTEUR PAS À PAS RÉFRIGÉRATEUR	WHRD 16
		WH 17
		WH 18
		SB/BK 19
		PR/RD 20
		21-22
		PRWH 23
		GY/YL 24
		YL/WH 25
		BO 27
		BNWH 29
		PK 31
		BL 26
		WH/BK 28
		YL 30
		RD 32
		GY/WH 33
		RD/YL 34



Trouble Shooting

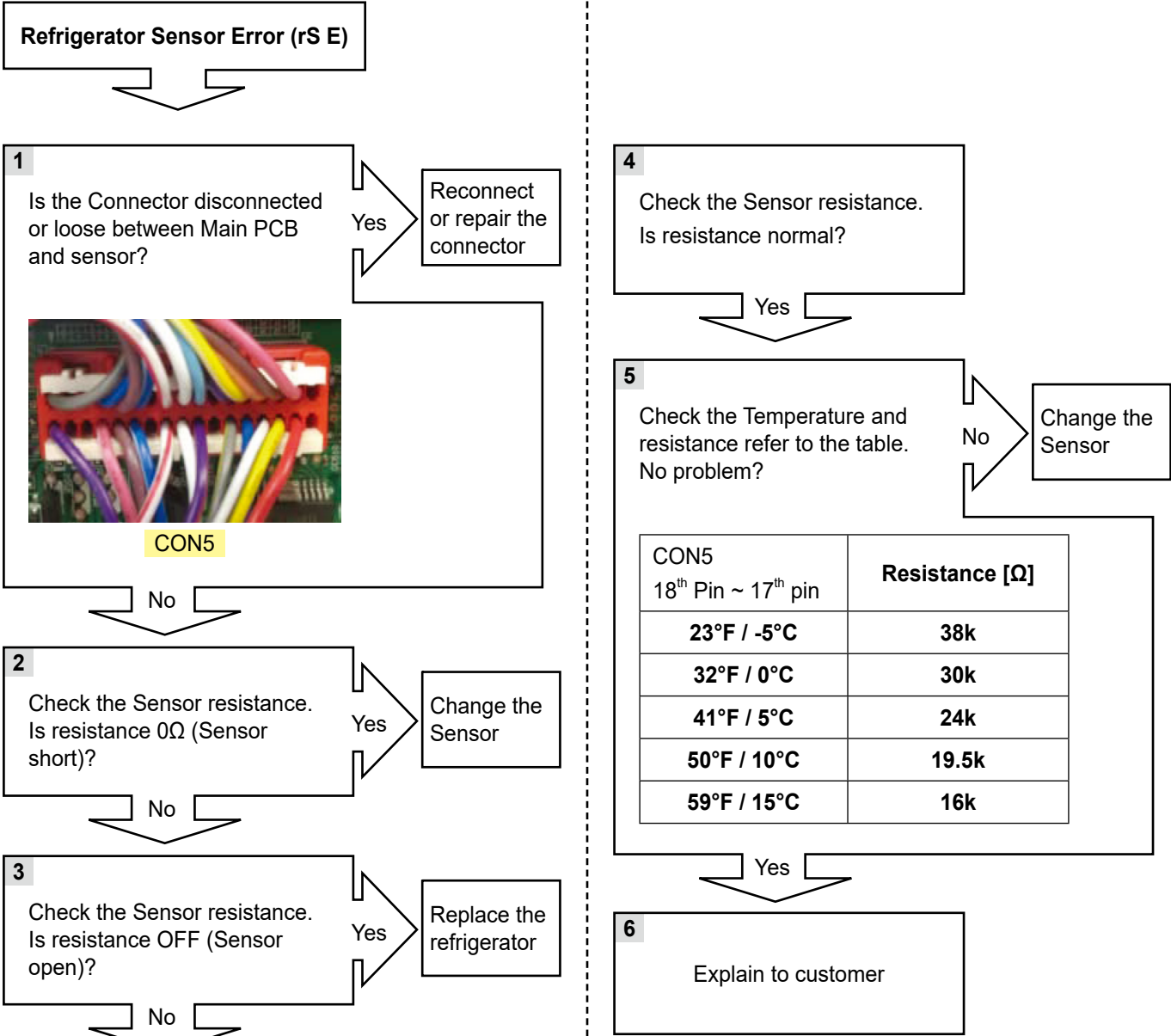



Trouble Shooting

Icing Sensor Error (IS E)

Symptom	Check Point
1. IS E	1. Check for a loose connection 2. Check Sensor Resistance

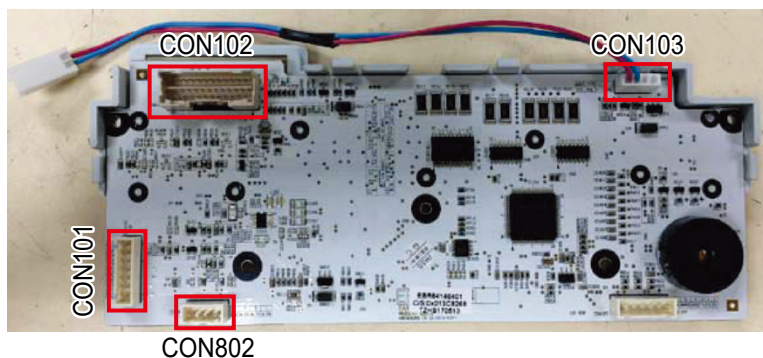

CON101

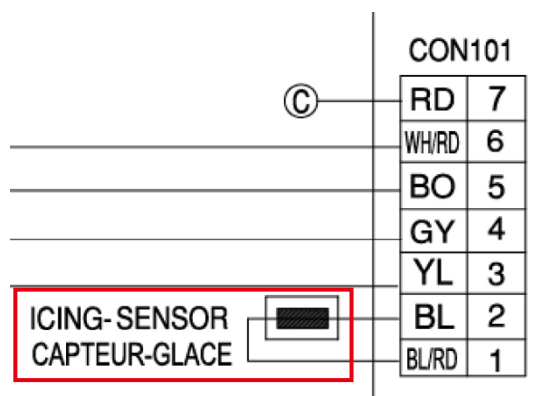

CON101 1 st Pin ~ 2 nd pin	Resistance [Ω]	
	Short	0
	Open	OFF
Other	Normal	

CON101 1 st Pin ~ 2 nd pin	Resistance [Ω]
-22°F / -30°C	40k
-13°F / -25°C	30k
-4°F / -20°C	23k
5°F / -15°C	17k
14°F / -10°C	13k
23°F / -5°C	10k
32°F / 0°C	8k



Trouble Shooting

Icing Sensor Error (IS E)

1 Is the Connector disconnected or loose between Main PCB and sensor?

Yes → Reconnect or repair the connector

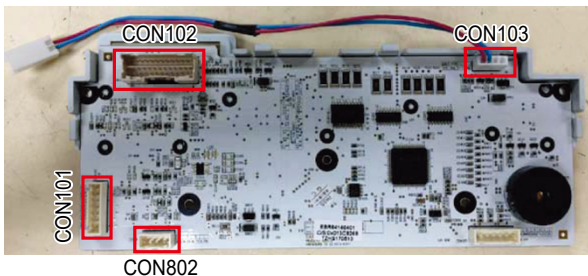

CON101

No

2 Check the Sensor resistance. Is resistance 0Ω (Sensor short)?

Yes → Change the Sensor

No

3 Check the Sensor resistance. Is resistance OFF (Sensor open)?

Yes → Replace the refrigerator

No

4 Check the Sensor resistance. Is resistance normal?

Yes

5 Check the Temperature and resistance refer to the table. No problem?

No → Change the Sensor

CON101 1 st Pin ~ 2 nd pin	Resistance [Ω]
-22°F / -30°C	40k
-13°F / -25°C	30k
-4°F / -20°C	23k
5°F / -15°C	17k
14°F / -10°C	13k
23°F / -5°C	10k
32°F / 0°C	8k

Yes

6 Explain to customer



Trouble Shooting

Defrost Sensor Error (dS F)

Symptom	Check Point
1. dS F	1. Check for a loose connection 2. Check Sensor Resistance

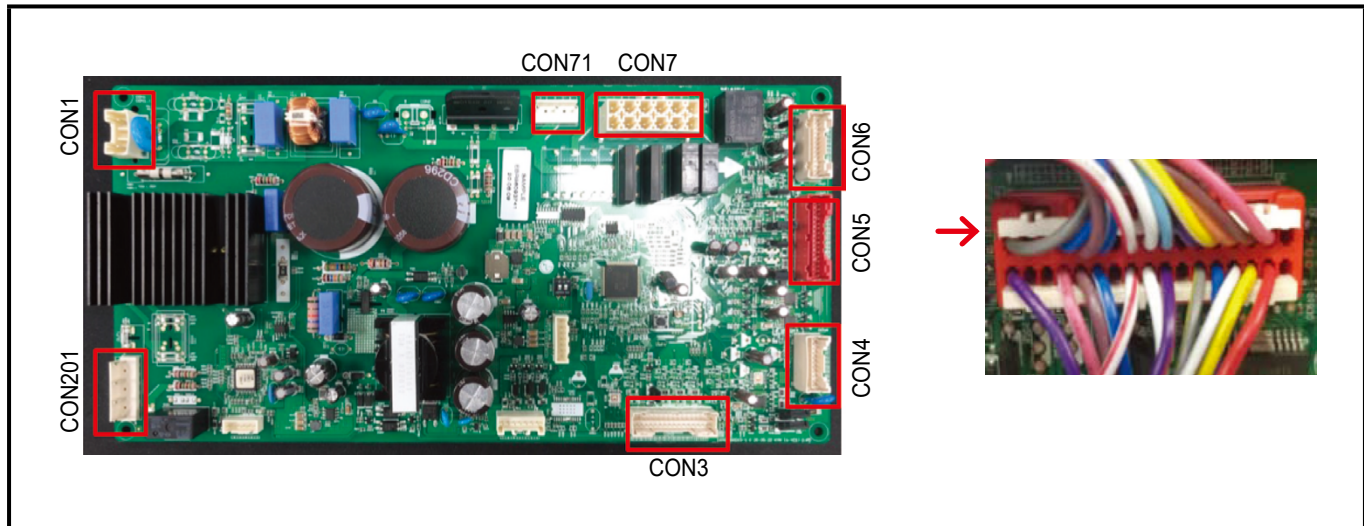

		Resistance [Ω]	
CON5 10 th Pin ~ 9 th pin	Short	0	
	Open	OFF	
	Other	Normal	

CON5 10 th Pin ~ 9 th pin	Resistance [Ω]
23°F / -5°C	38k
32°F / 0°C	30k
41°F / 5°C	24k
50°F / 10°C	19.5k
59°F / 15°C	16k

F-ROOM ICE VALVE PIÈCE CONGELATEUR CLAPET À GLAÇONS	R-ROOM LED MODULE MODULE LED PIÈCE R	BLRD 7
	D-SENSOR CAPTEUR D	PKWH 8
	F-SENSOR CAPTEUR F	BN 9
	PANTRY-SENSOR DÉTECTEUR DE COMPTOIR	BN 10
	R-SENSOR CAPTEUR R	BLWH 11
	BETA DUCT HEATER BETA DU CHAUFFAGE	BLWH 12
	F WATER PIPE HEATER RECHAUFFEUR CONDUITE D'EAU	13-14
	PANTRY STEPPING MOTOR MOTEUR PAS À PAS DE COMPTOIR	WHRD 15
	REFRIGERATOR STEPPING MOTOR MOTEUR PAS À PAS RÉFRIGÉRATEUR	WHRD 16
		WH 17
		WH 18
		SB/BK 19
		PR/RD 20
		21-22
		PRWH 23
		GY/YL 24
		YLWH 25
		BO 27
		BNWH 29
		PK 31
		BL 26
		WH/BK 28
		YL 30
		RD 32
		GYWH 33
		RD/YL 34



Trouble Shooting

Defrost Sensor Error (dS F)

1

Is the Connector disconnected or loose between Main PCB, Defrost controller and Sensor?

Yes → Reconnect or repair the connector

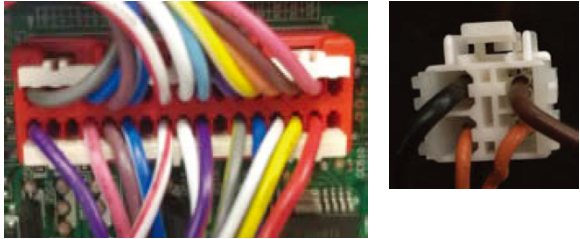

CON5

No → [Next Step]

2

Check the Sensor resistance. Is resistance 0Ω (Sensor short) or resistance Infinity Ω (Sensor open)?

Yes → Change the Sensor

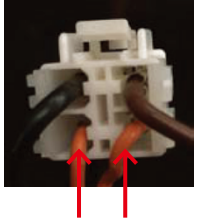

No → [Next Step]

3

Check the Sensor resistance. Is resistance normal?

Yes → [Next Step]

4

Check the Temperature and resistance refer to the table. No problem?

No → Change the Sensor

CON5 10 th Pin ~ 9 th pin	Resistance [Ω]
23°F / -5°C	38k
32°F / 0°C	30k
41°F / 5°C	24k
50°F / 10°C	19.5k
59°F / 15°C	16k

Yes → [Next Step]

5

Explain to customer



Trouble Shooting

Ice Maker Motor Error (It E)

Symptom	Check Point
1. It E	1. Check the Ice maker rotation 2. Check the motor voltage

(P/No. : EBR881246**)

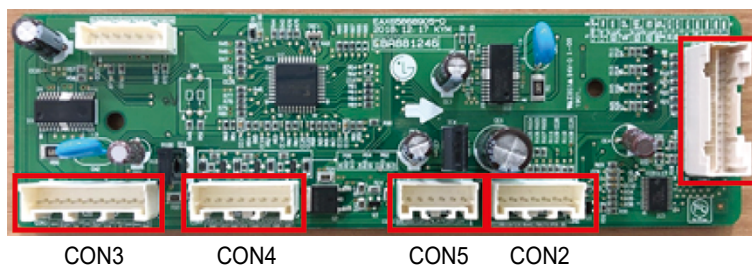

(1) Pin2, (2) Pin5, (3) Pin8

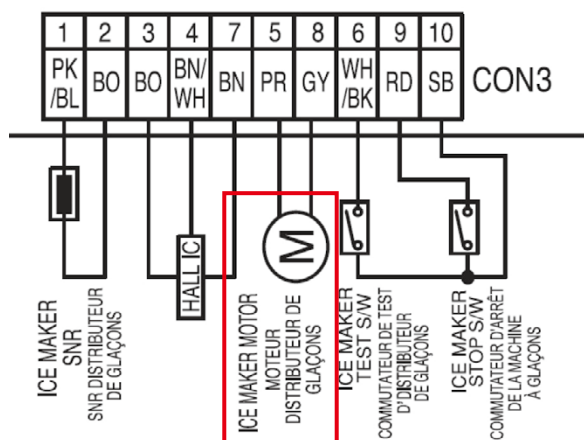

(P/No. : EBR881246**)

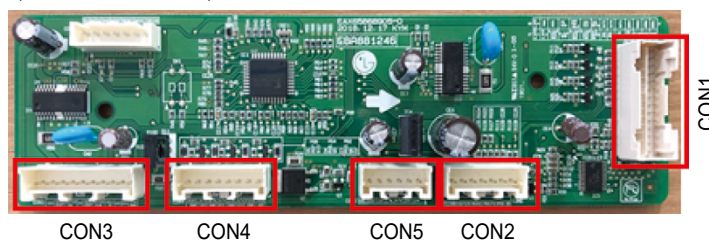



Trouble Shooting



Ice Maker Motor Error (It E)

1

Input Ice Maker test mode(Push the ice maker test button), check the Ice Tray, Ice maker motor Rotate?

Yes → Explain to customer

No →

2

Check the ice maker forward status
The voltage (1)~(2) point 11~12V?

Yes → Change the Ice maker kit

No →

(P/No. : EBR881246**)

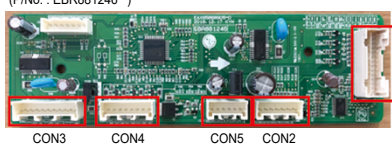
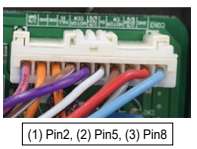
OR

3

Check the ice maker reverse status
The voltage (1)~(3) point 11~12V?

Yes → Change the Ice maker kit

No →

(P/No. : EBR881246**)

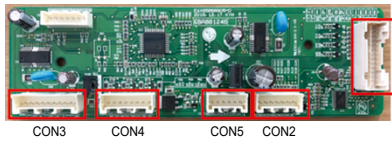
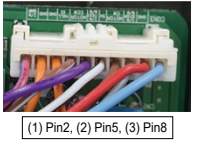
OR

4

Check the ice maker forward status
The voltage (1)~(2) point 0V?

Yes → Change the Main PCB

No →

(P/No. : EBR881246**)

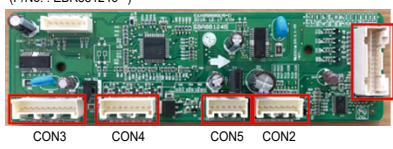
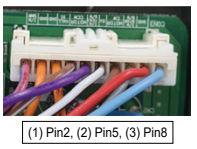
OR

3

Check the ice maker reverse status
The voltage (1)~(3) point 0V?

Yes → Change the Main PCB

No →

(P/No. : EBR881246**)

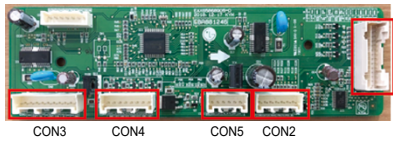
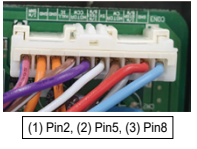





Trouble Shooting

Defrost Heater Error (dH F)

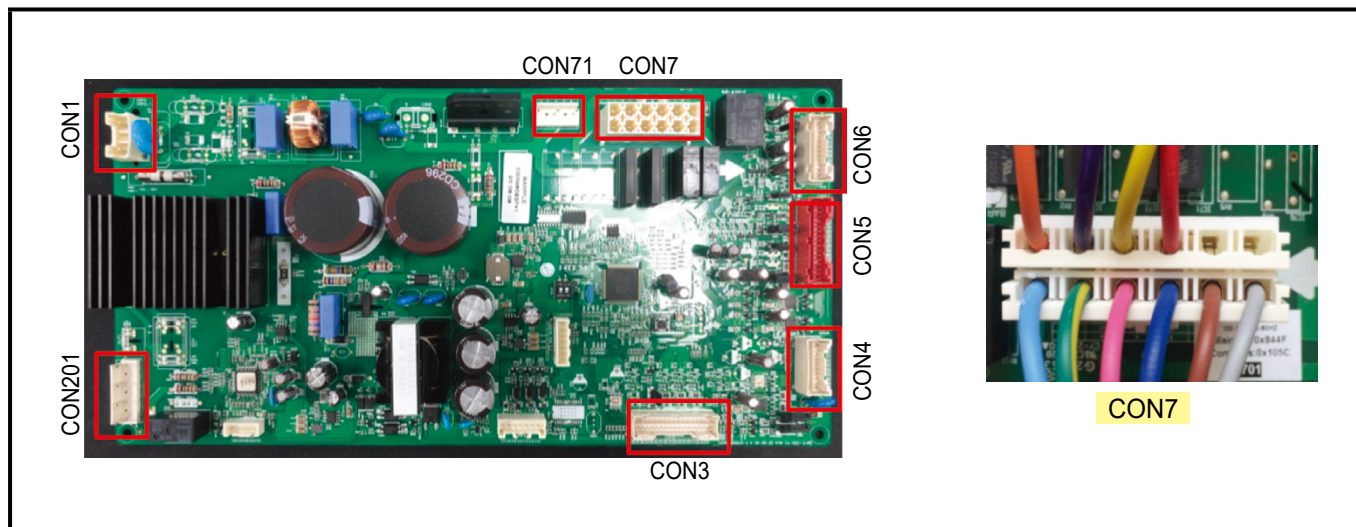
Symptom	Check Point
1. dH F	1. Check the door gasket 2. Check the Defrost control part 3. Check the PCB output voltage



POWER CORD / CORDON D'ALIMENTATION

NEUTRAL / NEUTRE

LIVE / TENSION

REACTOR / RÉACTEUR

FUSE / FUSIBLE

GN/YL

PILLAR HTR / PILIER DE CHAUFFAGE

H/BAR HTR / H/BAR CHAUFFAGE

GID HTR / GID CHAUFFAGE

DEF-HEATER / DEF-CHAUFFAGE

FUSE-M / FUSIBLE M

EARTH PART / PIÈCE DE MISE À LA TERRE

Part	Resistance [Ω]
FUSE-M	0
Defrost Heater	34 ~ 42
Defrost Sensor	22k \uparrow

TEST MODE 3	Voltage [V]
CON7 6 th pin ~ 12 th Pin	112V ~ 116V

TEST MODE 1	Voltage [V]
CON7 6 th pin ~ 12 th Pin	0V



Trouble Shooting

Defrost Heater Error (dH F)

1 Check the Door gasket.
Is door gasket damaged?

Yes → Replace the Door gasket

No →

2 Check the Defrost control part.
(1) Is Fuse-M resistance 34~42Ω?

No → Change Defrost Heater

Yes →

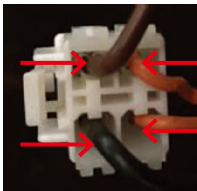

3 Check the Defrost control part.
Is Defrost Sensor resistance 22kΩ↑ or OFF?

OFF → Replace product

22kΩ↑ →

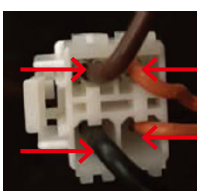

4 **Input Test 3 Mode (Push the button 3 times)**
Check the Heater Voltage.
Is voltage 112~116V?

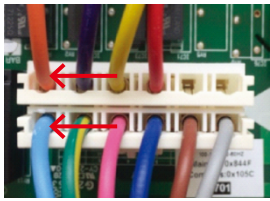

TEST MODE 3	Voltage [V]
CON7 6 th pin ~ 12 th Pin	112V ~ 116V

No → Replace Main PCB

Yes →

5 **Input Test 1 Mode (Push the button 1 times)**
Check the Heater Voltage.
Is voltage 0V?

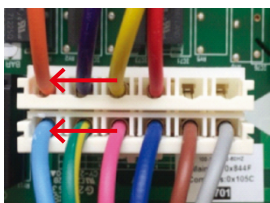

TEST MODE 1	Voltage [V]
CON7 6 th pin ~ 12 th Pin	0V

No → Replace Main PCB

Yes →

6 Explain to customer



Trouble Shooting

Freezer Fan Error (FF E)

Symptom	Check Point
1. FF E	1. Check the air flow 2. Check the Fan Motor 3. Check the PCB Fan motor voltage

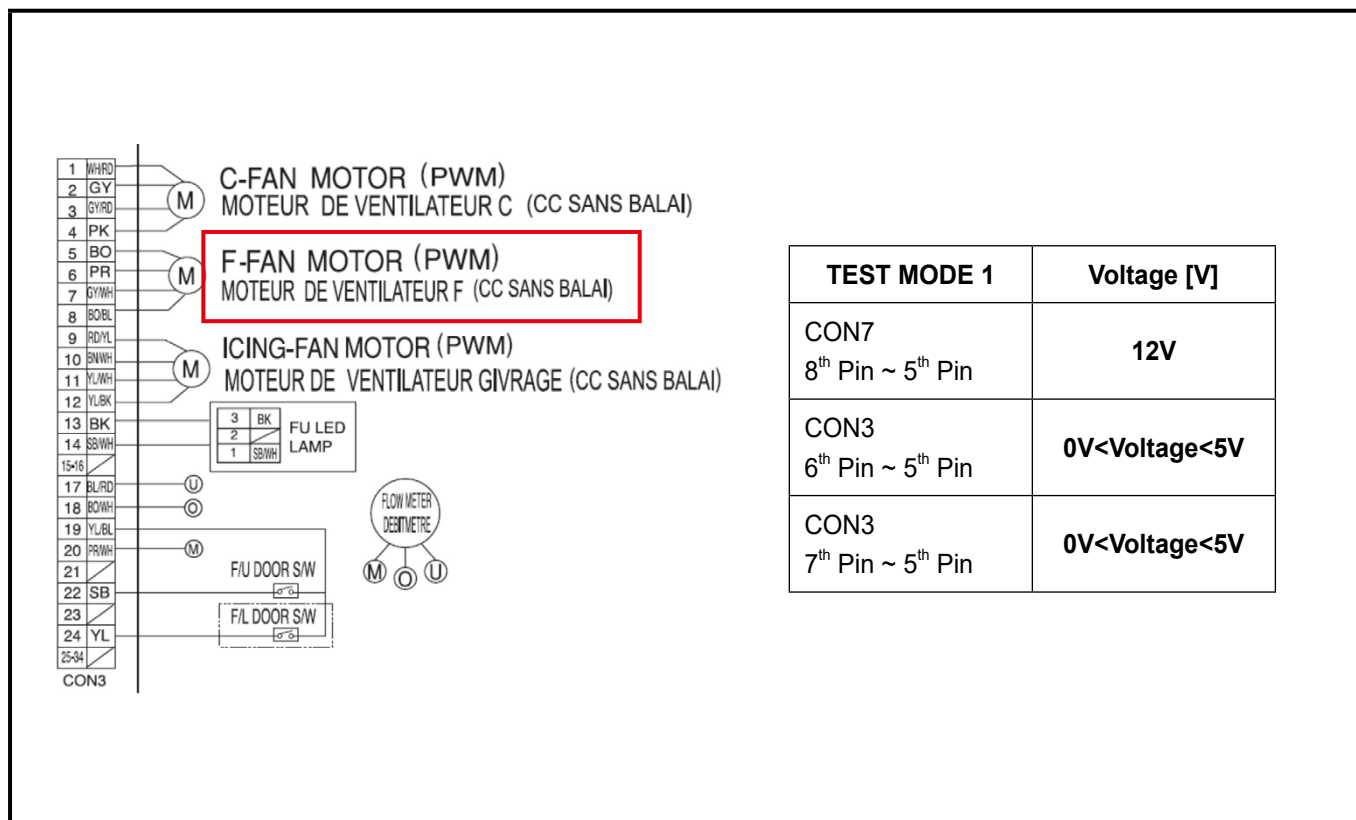
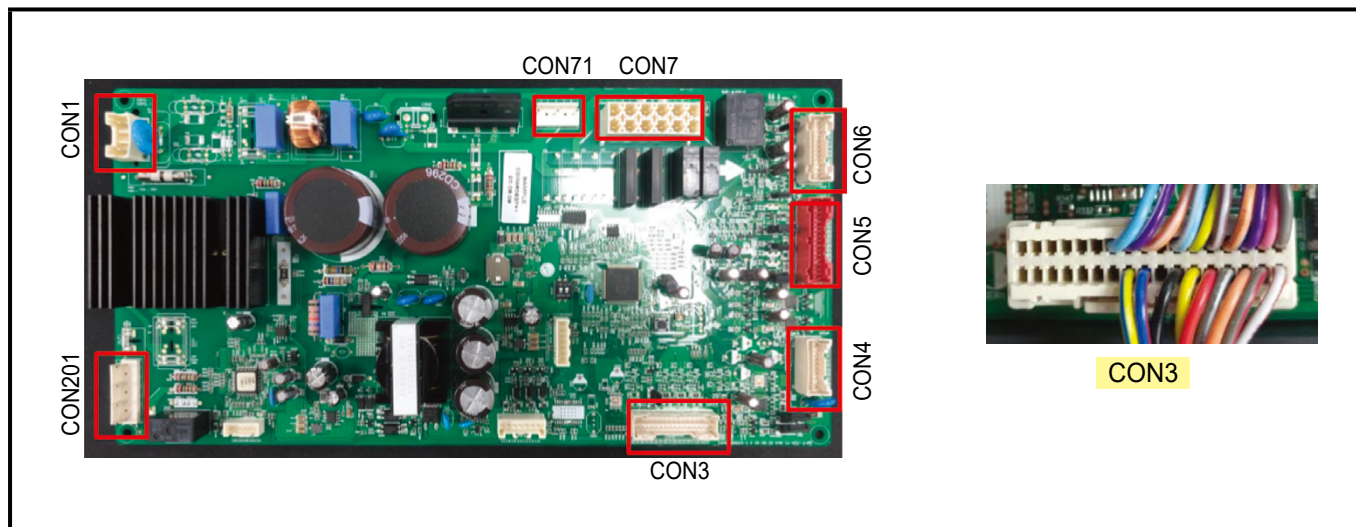





Trouble Shooting

Freezer Fan Error (FF E)

1

Reset the unit and Input Test1 Mode.
(Push the button 1 time)

2

Open the freezer door and Check the air flow. Windy?

No → Go to 3



Yes → Go to 4

3

Check the Fan motor.
Rotate fan using hand.
It feel sticky?

Yes → Change the Fan motor

Fan Motor

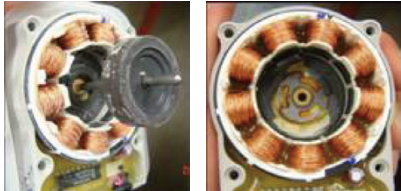

4

Check the Fan Motor voltage
Is Fan Motor voltage 12V?

No → Replace Main PCB



TEST MODE 1	Voltage [V]
CON3 8 th Pin ~ 5 th Pin	12V

Yes → Go to 5

5

Check the Fan Motor voltage
Is Fan control signal voltage
between 0V and 5V?

No → Replace Main PCB



TEST MODE 1	Voltage [V]
CON3 6 th Pin ~ 5 th Pin	0V<Voltage<5V

No → Go to 6

6

Check the Fan Motor voltage
Is Fan feed back voltage
between 0V and 5V?

No → Replace Motor



TEST MODE 1	Voltage [V]
CON3 7 th Pin ~ 5 th Pin	0V<Voltage<5V

No → Go to 7

7

Explain to customer



Trouble Shooting

Icing Fan Error (IF E)

Symptom	Check Point
1. IF E	1. Check the air flow 2. Check the Connector 3. Check the PCB Fan motor voltage

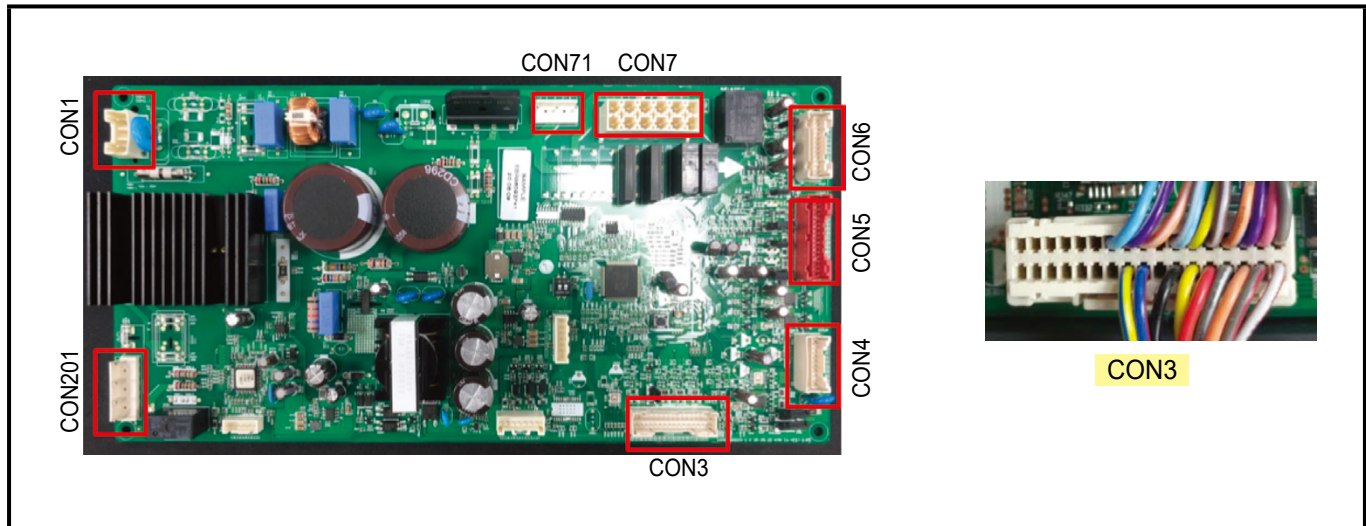

TEST MODE 1	Voltage [V]
CON3 12 th Pin ~ 9 th Pin	12V
CON3 10 th Pin ~ 9 th Pin	0V<Voltage<5V
CON3 11 st Pin ~ 9 th Pin	0V<Voltage<5V

1	WH/RD	C-FAN MOTOR (PWM) MOTEUR DE VENTILATEUR C (CC SANS BALAI)	M
2	GY		
3	GY/RD		
4	PK	F-FAN MOTOR (PWM) MOTEUR DE VENTILATEUR F (CC SANS BALAI)	M
5	BO		
6	PR		
7	GY/WH		
8	RY/BL	ICING-FAN MOTOR (PWM) MOTEUR DE VENTILATEUR GIVRAGE (CC SANS BALAI)	M
9	RD/YL		
10	BN/WH		
11	YL/WH		
12	YL/BL		
13	BK	FU LED LAMP	
14	SB/WH		
15-16			





Trouble Shooting

Freezer Fan Error (E IF)

1

Reset the unit and Input Test1 Mode.
(Push the button 1 time)

2

Open the freezer door and Check the air flow. Windy?



No → Go to 3

Yes → Go to 4

3

Check the Fan motor.
Rotate fan using hand.
It feel sticky?

Yes → Change the Fan motor

Fan Motor

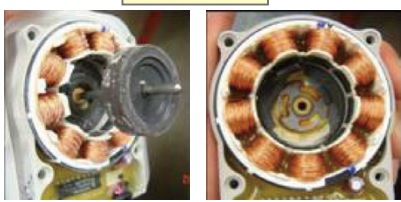

4

Check the Fan Motor voltage
Is Fan Motor voltage 12V?



CON3

TEST MODE 1	Voltage [V]
CON3 12 th Pin ~ 9 th Pin	12V

No → Replace Main PCB

Yes → Go to 5

5

Check the Fan Motor voltage
Is Fan control signal voltage
between 0V and 5V?



CON3

TEST MODE 1	Voltage [V]
CON3 10 th Pin ~ 9 th Pin	0V<Voltage<5V

No → Replace Main PCB

Yes → Go to 6

6

Check the Fan Motor voltage
Is Fan feed back voltage
between 0V and 5V?



CON3

TEST MODE 1	Voltage [V]
CON3 11 st Pin ~ 9 th Pin	0V<Voltage<5V

No → Replace Motor

Yes → Go to 7

7

Explain to customer



Trouble Shooting

Condenser Fan Error (CF E)

Symptom	Check Point
1. CF E	1. Check the air flow 2. Check the Connector 3. Check the PCB Fan motor voltage

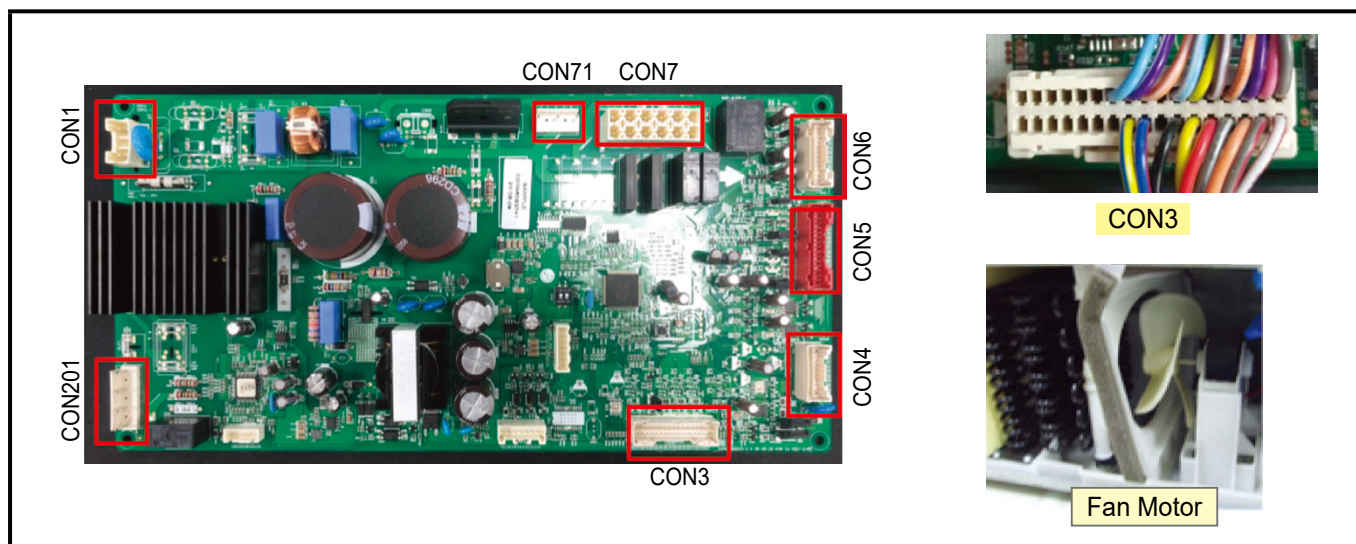

<table border="1"> <tbody> <tr> <td>1</td> <td>WH/RO</td> <td rowspan="4"> C-FAN MOTOR (PWM) MOTEUR DE VENTILATEUR C (CC SANS BALAI) </td> </tr> <tr> <td>2</td> <td>GY</td> </tr> <tr> <td>3</td> <td>GY/RO</td> </tr> <tr> <td>4</td> <td>PK</td> </tr> <tr> <td>5</td> <td>BO</td> <td rowspan="4"> F-FAN MOTOR (PWM) MOTEUR DE VENTILATEUR F (CC SANS BALAI) </td> </tr> <tr> <td>6</td> <td>PR</td> </tr> <tr> <td>7</td> <td>GY/WH</td> </tr> <tr> <td>8</td> <td>BO/BL</td> </tr> <tr> <td>9</td> <td>RO/YL</td> <td rowspan="4"> ICING-FAN MOTOR (PWM) MOTEUR DE VENTILATEUR GIVRAGE (CC SANS BALAI) </td> </tr> <tr> <td>10</td> <td>BN/WH</td> </tr> <tr> <td>11</td> <td>YL/WH</td> </tr> <tr> <td>12</td> <td>YL/BK</td> </tr> <tr> <td>13</td> <td>BK</td> <td rowspan="2"> <table border="1"> <tbody> <tr> <td>3</td> <td>BK</td> <td rowspan="2">FU LED LAMP</td> </tr> <tr> <td>2</td> <td>SB/WH</td> </tr> </tbody> </table> </td> </tr> <tr> <td>14</td> <td>SB/WH</td> <td></td> </tr> <tr> <td>15-16</td> <td></td> <td></td> </tr> </tbody> </table>	1	WH/RO	C-FAN MOTOR (PWM) MOTEUR DE VENTILATEUR C (CC SANS BALAI)	2	GY	3	GY/RO	4	PK	5	BO	F-FAN MOTOR (PWM) MOTEUR DE VENTILATEUR F (CC SANS BALAI)	6	PR	7	GY/WH	8	BO/BL	9	RO/YL	ICING-FAN MOTOR (PWM) MOTEUR DE VENTILATEUR GIVRAGE (CC SANS BALAI)	10	BN/WH	11	YL/WH	12	YL/BK	13	BK	<table border="1"> <tbody> <tr> <td>3</td> <td>BK</td> <td rowspan="2">FU LED LAMP</td> </tr> <tr> <td>2</td> <td>SB/WH</td> </tr> </tbody> </table>	3	BK	FU LED LAMP	2	SB/WH	14	SB/WH		15-16			<table border="1"> <thead> <tr> <th>TEST MODE 1</th> <th>Voltage [V]</th> </tr> </thead> <tbody> <tr> <td>CON3 4th Pin ~ 1st Pin</td> <td>12V</td> </tr> <tr> <td>CON3 2nd Pin ~ 1st Pin</td> <td>0V<Voltage<5V</td> </tr> <tr> <td>CON3 3rd Pin ~ 1st Pin</td> <td>0V<Voltage<5V</td> </tr> </tbody> </table>	TEST MODE 1	Voltage [V]	CON3 4 th Pin ~ 1 st Pin	12V	CON3 2 nd Pin ~ 1 st Pin	0V<Voltage<5V	CON3 3 rd Pin ~ 1 st Pin	0V<Voltage<5V
1	WH/RO	C-FAN MOTOR (PWM) MOTEUR DE VENTILATEUR C (CC SANS BALAI)																																																
2	GY																																																	
3	GY/RO																																																	
4	PK																																																	
5	BO	F-FAN MOTOR (PWM) MOTEUR DE VENTILATEUR F (CC SANS BALAI)																																																
6	PR																																																	
7	GY/WH																																																	
8	BO/BL																																																	
9	RO/YL	ICING-FAN MOTOR (PWM) MOTEUR DE VENTILATEUR GIVRAGE (CC SANS BALAI)																																																
10	BN/WH																																																	
11	YL/WH																																																	
12	YL/BK																																																	
13	BK	<table border="1"> <tbody> <tr> <td>3</td> <td>BK</td> <td rowspan="2">FU LED LAMP</td> </tr> <tr> <td>2</td> <td>SB/WH</td> </tr> </tbody> </table>	3	BK	FU LED LAMP	2	SB/WH																																											
3	BK		FU LED LAMP																																															
2	SB/WH																																																	
14	SB/WH																																																	
15-16																																																		
TEST MODE 1	Voltage [V]																																																	
CON3 4 th Pin ~ 1 st Pin	12V																																																	
CON3 2 nd Pin ~ 1 st Pin	0V<Voltage<5V																																																	
CON3 3 rd Pin ~ 1 st Pin	0V<Voltage<5V																																																	





Trouble Shooting

Condenser Fan Error (CF E)

1

Reset the unit and Input Test1 Mode.
(Push the button 1 time)

2

Check the fan rotating.
Does fan rotate?

No → Go to 3

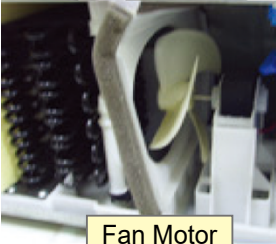

Fan Motor

Yes → Go to 4

3

Check the Fan motor.
Rotate fan using hand.
It feel sticky?

Yes → Change the Fan motor

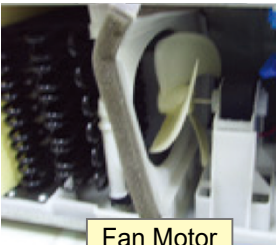

Fan Motor

4

Check the Fan Motor voltage
Is Fan Motor voltage 12V?

No → Replace Main PCB



CON3

TEST MODE 1	Voltage [V]
CON3 4 th Pin ~ 1 st Pin	12V

Yes → Go to 5

5

Check the Fan Motor voltage
Is Fan control signal voltage
between 0V and 5V?

No → Replace Main PCB



CON3

TEST MODE 1	Voltage [V]
CON3 2 nd Pin ~ 1 st Pin	0V<Voltage<5V

No → Go to 6

6

Check the Fan Motor voltage
Is Fan feed back voltage
between 0V and 5V?

No → Replace Motor



CON3

TEST MODE 1	Voltage [V]
CON3 3 rd Pin ~ 1 st Pin	0V<Voltage<5V

No → Go to 7

7

Explain to customer



Trouble Shooting

Communication Error (CO E)

Symptom	Check Point
1. CO E	1. Check the loose connection 2. Check the Hinge connection

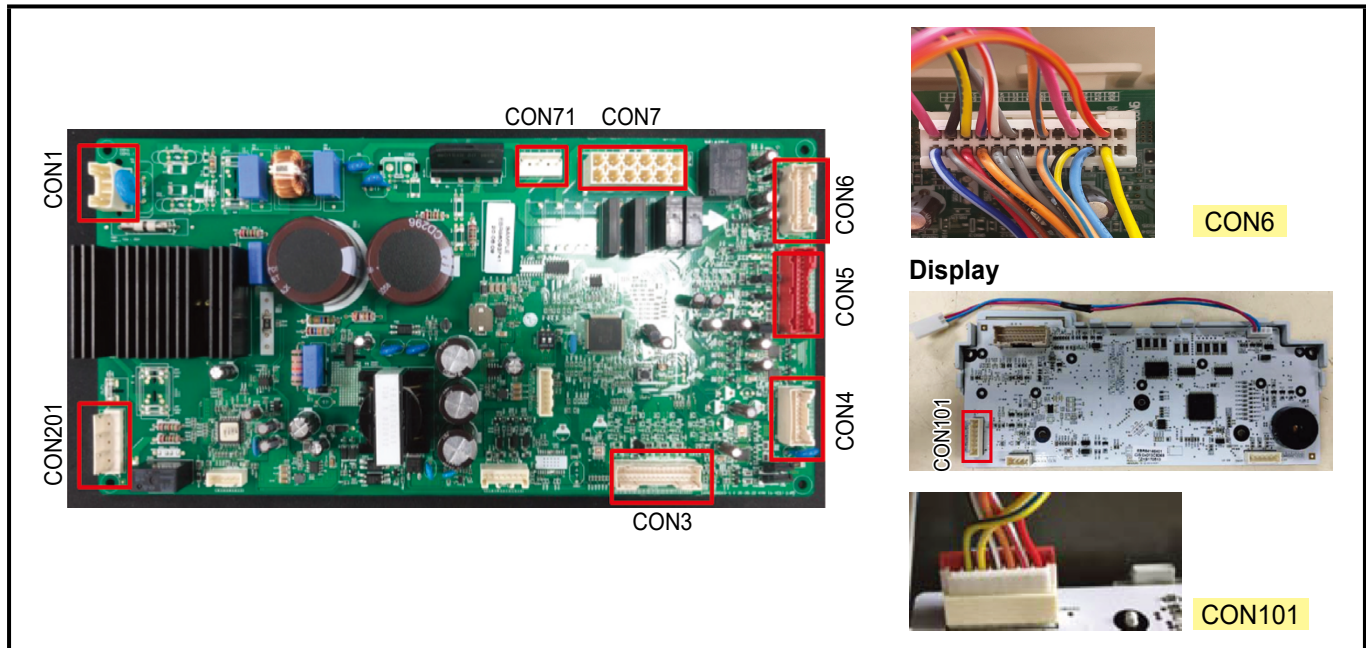

		Voltage [V]
CON101	7 th Pin ~ 6 th Pin	12V
CON101	5 th Pin ~ 6 th Pin	Not 0V, 5V
CON101	4 th Pin ~ 6 th Pin	Not 0V, 5V
CON101	3 th Pin ~ 6 th Pin	5V

Housing	Voltage [V]
CON6 8 th Pin ~ 9 th Pin	Not 0V, 5V
CON6 10 th Pin ~ 9 th Pin	Not 0V, 5V



Trouble Shooting

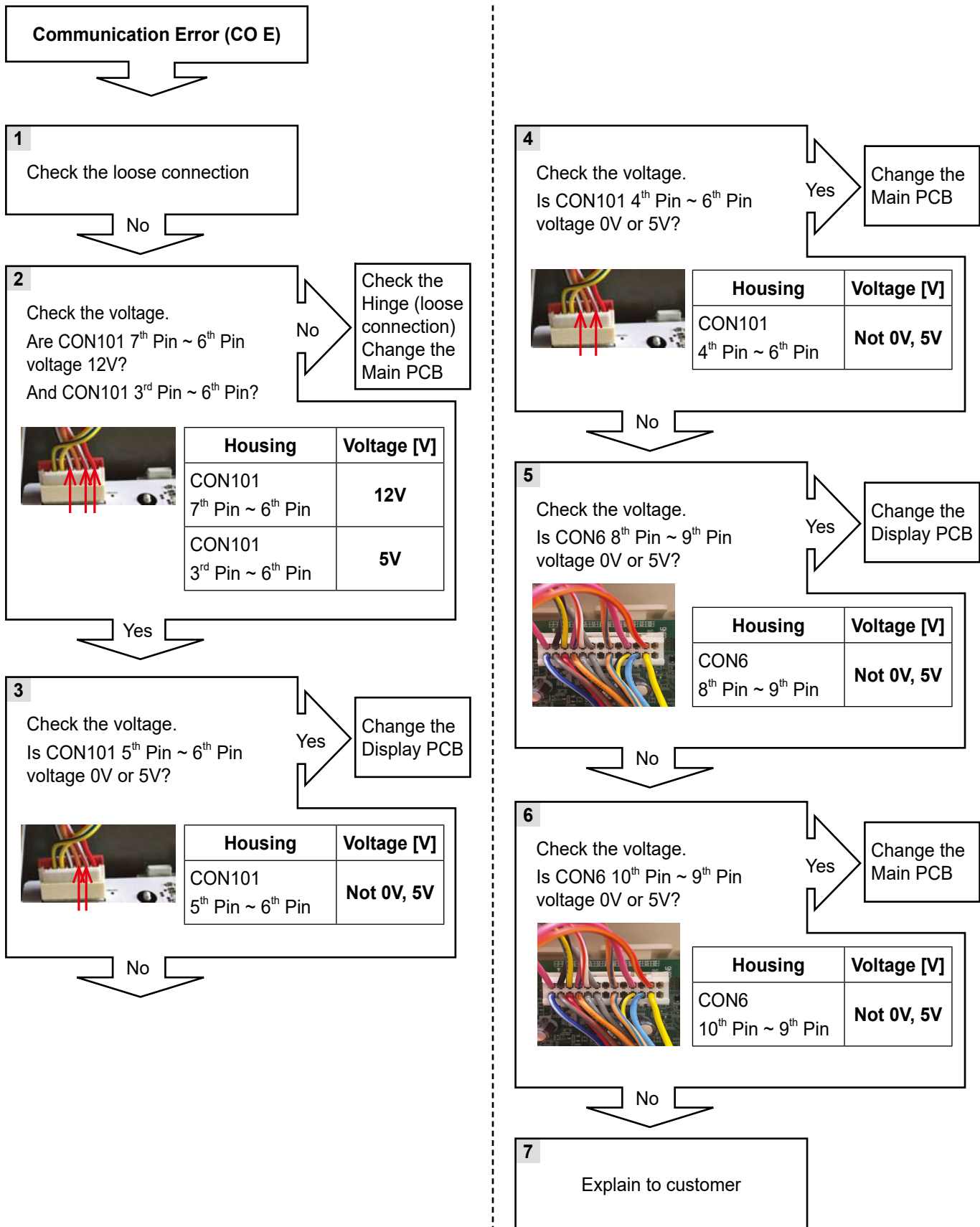



Trouble Shooting

Cube mode doesn't work

Symptom	Check Point
1. Cube mode doesn't work	1. Check the loose connection 2. Check the resistance

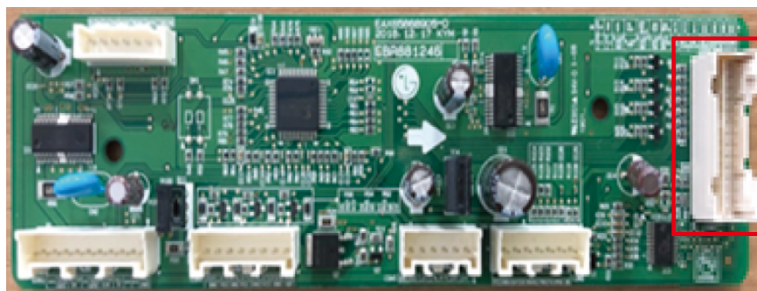

CON3 CON4 CON5 CON2

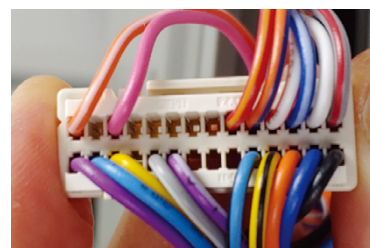

CON1



Ice Maker

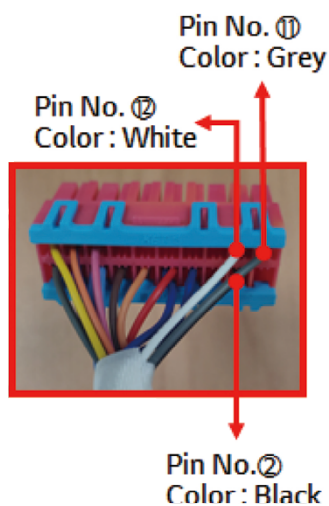

Geared Motor
(BLDC Type)



Dispenser Motor



Trouble Shooting

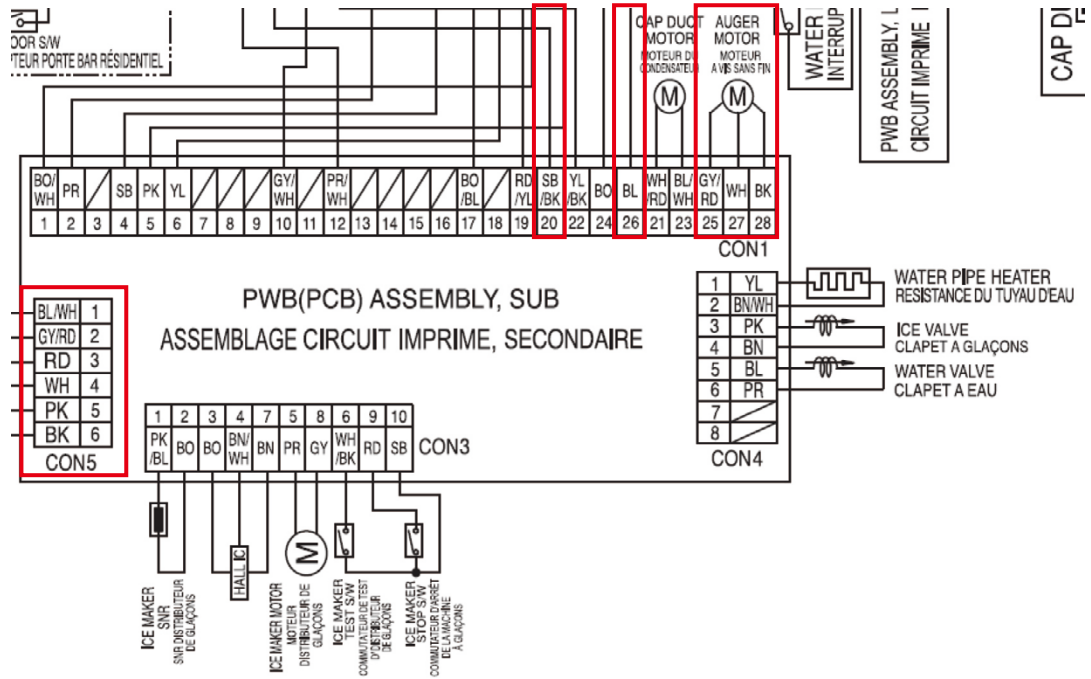

	Resistance [Ω]
CON1 25 th Pin, 27 th Pin 25 th Pin, 28 th Pin 27 th Pin, 28 th Pin	2.37 ~ 2.73 Ω

	Voltage [V]
CON5 1 st Pin, 5 th Pin	24V ± 10%

Pushing The LEVER S/W	Voltage [V]
CON1 CON5 20 th Pin, 5 th Pin 26 th Pin, 5 th Pin	5V ± 10%



Trouble Shooting

Cube mode doesn't work

1
Check the Auger Motor
(Working Sound, Visual inspection)

Yes

2
Check the SUB PCB Resistance Value



Change the Dispenser Assembly, Ice (Loc. 612A)

CON1 25 th Pin, 27 th Pin 25 th Pin, 28 th Pin 27 th Pin, 28 th Pin	Resistance [Ω]
U, V, W	2.37 ~ 2.73

Yes

3
Check the SUB PCB Voltage Value



Check the Item ⑤ (Main PCB Voltage value)

※ Sub PCB Voltage NG or, When Main PCB Voltage is OK, Estimated Harness open circuit.

CON5 1 st Pin, 5 th Pin	Voltage [V]
24V	24V ± 10%

While pushing the lever S/W is voltage correct?

CON1 CON5 26 th Pin, 5 th Pin	Voltage [V]
PWM	5V ± 10%



Change the Case Assembly, PCB (Loc.500C)

CON1 CON5 20 th Pin, 5 th Pin	Voltage [V]
24V Enable	5V ± 10%

Yes

4
Check the Display PCB Voltage Value

Change the Cover Assembly Display (Loc. 279A)



CON102 29 th Pin, 3 rd Pin	Voltage [V]
PWM	5V ± 10%

CON102 28 th Pin, 3 rd Pin	Voltage [V]
24V Enable	5V ± 10%

Yes

5
Check the Main PCB Voltage Value

Change the PCB Assembly, Main (Loc. 500A)

CON5 1 st Pin, 13 th Pin	Voltage [V]
24V	24V ± 10%

Yes

6
Explain to the customer
(Refrigerator is OK)



Trouble Shooting

Crush mode doesn't work

Symptom	Check Point
1. Crush mode doesn't work	1. Check the loose connection 2. Check the resistance

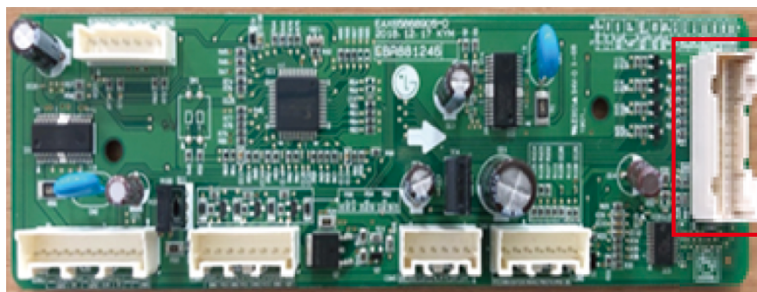

CON3 CON4 CON5 CON2



CON1



Ice Maker

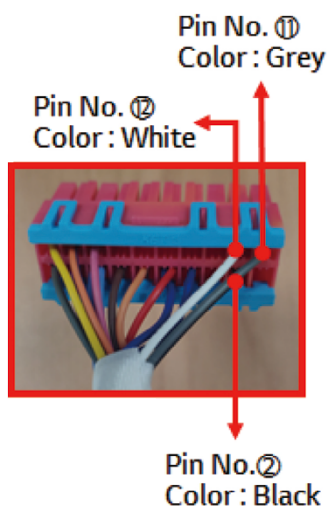

Geared Motor
(BLDC Type)



Dispenser Motor



Trouble Shooting

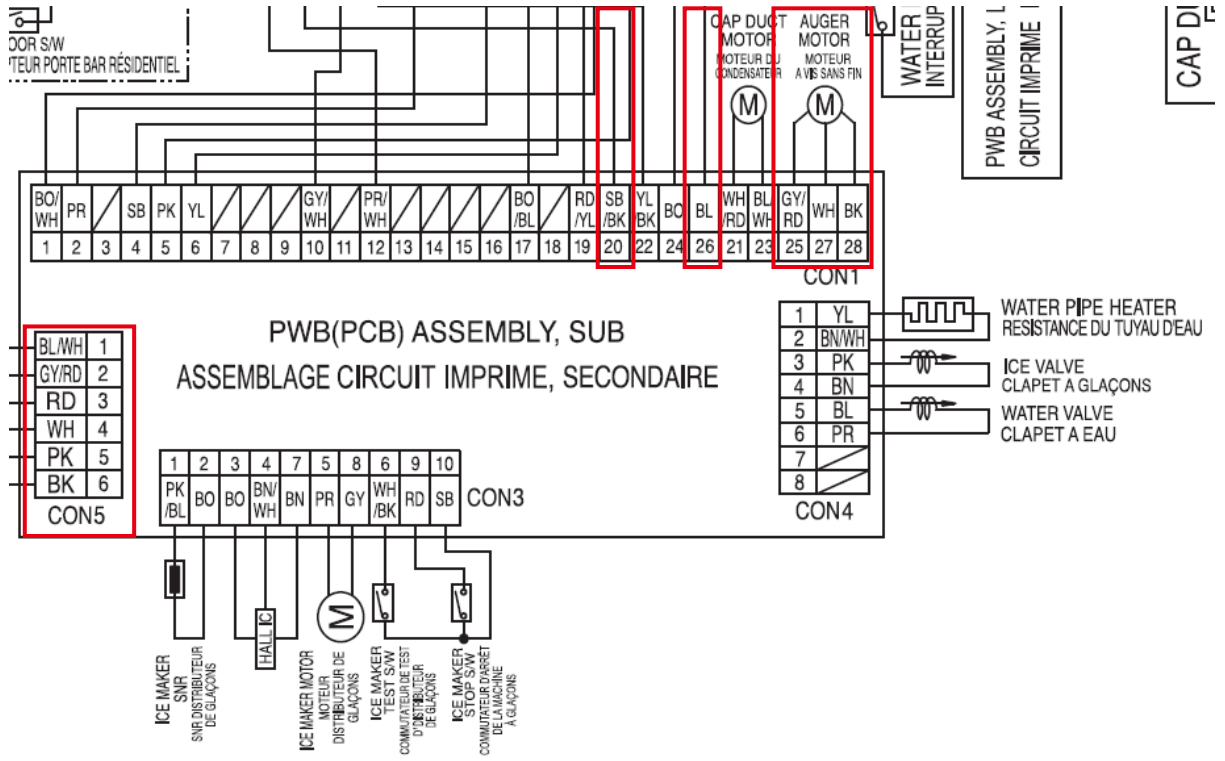

	Resistance [Ω]
CON1 25 th Pin, 27 th Pin 25 th Pin, 28 th Pin 27 th Pin, 28 th Pin	2.37 ~ 2.73Ω

	Voltage [V]
CON5 1 st Pin, 5 th Pin	24 \pm 10%

Pushing The LEVER S/W	Voltage [V]
CON1 CON5 20 th Pin, 5 th Pin 26 th Pin, 5 th Pin	5V \pm 10%



Trouble Shooting

Crush mode doesn't work

1 Check the Auger Motor (Working Sound, Visual inspection)

No → Check the Ice Bucket

2 Check the SUB PCB Resistance Value

No → Change the Dispenser Assembly, Ice (Loc. 612A)



CON1	Resistance [Ω]
25 th Pin, 27 th Pin	2.37 ~ 2.73Ω
25 th Pin, 28 th Pin	
27 th Pin, 28 th Pin	
U, V, W	2.37 ~ 2.73Ω

3 Check the SUB PCB Voltage Value

No → Check the Item ⑤ (Main PCB Voltage value)



CON1	Voltage [V]
1 st Pin ~ 5 th Pin	24V ± 10%
24V	

While pushing the lever S/W is voltage correct?



CON1	CON5	Voltage [V]
26 th Pin, 5 th Pin	5V ± 10%	
PWM		

No → Change the Case Assembly, PCB (Loc. 500C)

CON1	CON5	Voltage [V]
20 th Pin, 5 th Pin	5V ± 10%	
24V Enable		

4 Check the Display PCB Voltage Value

No → Change the Cover Assembly, Display (Loc. 279A)





CON102	Voltage [V]
29 th Pin, 3 rd Pin	5V ± 10%
PWM	

CON102	Voltage [V]
28 th Pin, 3 rd Pin	5V ± 10%
24V Enable	

5 Check the Main PCB Voltage Value

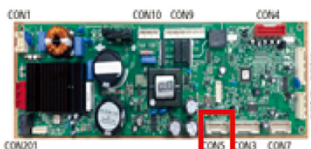
No → Change the PCB Assembly, Main (Loc. 500A)

CON5	Voltage [V]
1 st Pin ~ 13 th Pin	24V ± 10%
24V	

6 Explain to the customer (Refrigerator is OK)



Trouble Shooting

Water mode doesn't work

Symptom	Check Point
1. Water mode doesn't work	1. Check the loose connection 2. Check the resistance valve

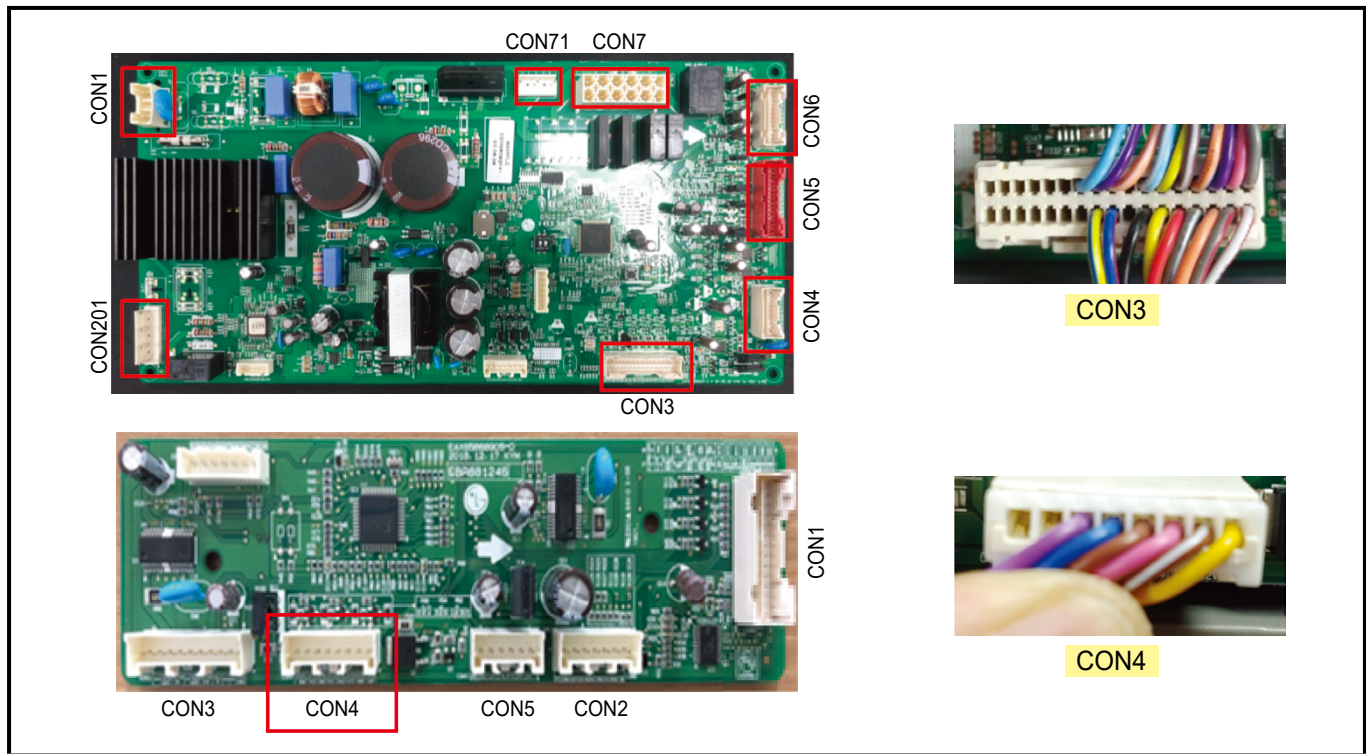

LEVER S/W	Voltage [V]	
CON5 5 th Pin & 33 th Pin	Pushing	20.4V ↑
	Not Pushing	0~2V
CON4 5 th Pin & 6 th Pin	Pushing	20.4V ↑
	Not Pushing	0~2V



Trouble Shooting

Water mode doesn't work

1
Check the loose connection

2
Check the voltage.
(while pushing the lever S/W)
Is voltage correct?
No → Change the PCB

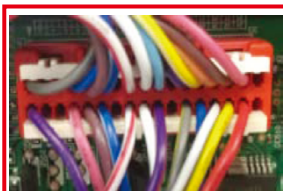

CON5



CON4

LEVER S/W	Voltage [V]	
	Pushing	Not Pushing
CON5 5 th Pin & 33 th Pin	20.4V ↑	0~2V
	0~2V	20.4V ↑
CON4 5 th Pin & 6 th Pin	20.4V ↑	0~2V
	0~2V	20.4V ↑

Yes

3
Check the resistance value.
Is Pilot Valve resistance
69.06 ~ 76.33Ω ?
No → Replace P/ Valve

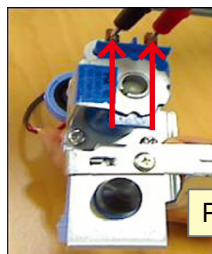

Pilot Valve

	Resistance [Ω]
Pilot Valve	69.06 ~ 76.33Ω

Yes

4
Check the resistance value.
Is Water Valve resistance
24.03 ~ 26.56Ω ?
No → Replace Water Valve

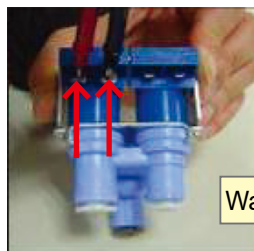

Water Valve

	Resistance [Ω]
Water valve	24.03 ~ 26.56

Yes

5
Explain to customer



Trouble Shooting

Refrigerator room lamp doesn't work

Symptom	Check Point
1. Refrigerator room lamp doesn't work	1. Check the Refrigerator door switch sticky 2. Check the door S/W resistance 3. Check the LED Lamp

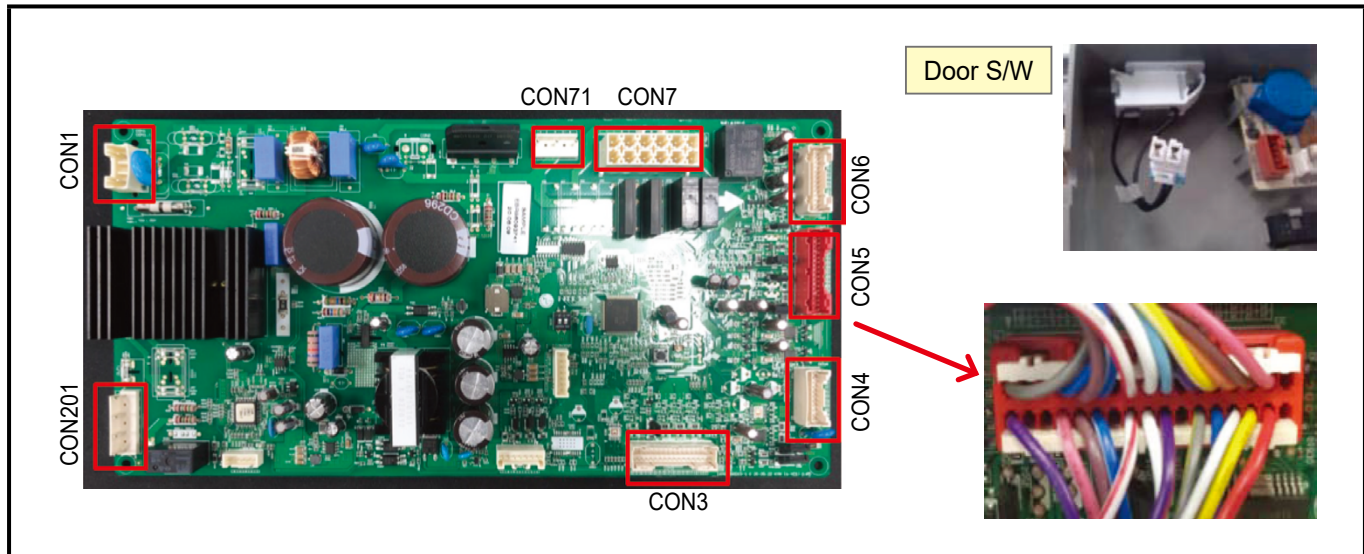

F-ROOM ICE VALVE PIÈCE CONGELATEUR CLAPET À GLAÇONS	R-ROOM LED MODULE MODULE LED PIÈCE R	BLRD 7
		PKWH 8
		BN 9
D-SENSOR CAPTEUR D		BN 10
F-SENSOR CAPTEUR F		BLWH 11
		BLWH 12
		13-14
PANTRY-SENSOR DÉTECTEUR DE COMPTOIR		WHRD 15
		WHRD 16
R-SENSOR CAPTEUR R		WH 17
		WH 18
BETA DUCT HEATER BETA DU CHAUFFAGE		SB/RK 19
		PR/RD 20
		21-22
F WATER PIPE HEATER RECHAUFFEUR CONDUITE D'EAU		PRWH 23
		GYM 24
		YLWH 25
PANTRY STEPPING MOTOR MOTEUR PAS À PAS DE COMPTOIR	(M)	BO 27
		BNWH 29
		PK 31
REFRIGERATOR STEPPING MOTOR MOTEUR PAS À PAS RÉFRIGÉRATEUR	(M)	BL 26
		WHBK 28
		YL 30
		RD 32
		GYWR 33
		RDYL 34

		S/W Resistance [Ω]	
Door	Open	Infinity	
	Close	0	

		Voltage [V]	
CON5	8 th Pin ~ 7 th Pin	12V	

LED Lamp		Voltage [V]	
White~ Yellow	Closed	0~2V	
	Open	12V	



Trouble Shooting

Refrigerator room lamp doesn't work

1 Check the Refrigerator door switch. Does it feel sticky?

Yes → Change the Door S/W

No → 2



2 Check the door S/W resistance. Is it correct compared with table?

No → Change the Door S/W

Yes → 3

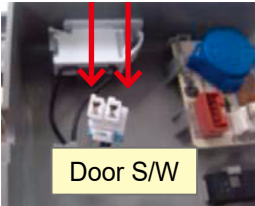

Door S/W

		S/W Resistance [Ω]	
Door	Open	Infinity	
	Close	0	

3 Check the PCB Voltage. Is CON5 8th Pin ~ 7th Pin voltage 12V?

No → Change the PCB

Yes → 4

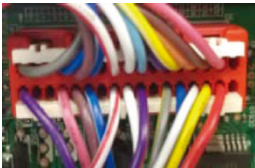

CON5

	Voltage [V]
CON5 8 th Pin ~ 7 th Pin	12V

4 Check the LED Lamp voltage. Is it 12V? (While door opened)

No → Change the LED Lamp

Yes → 5

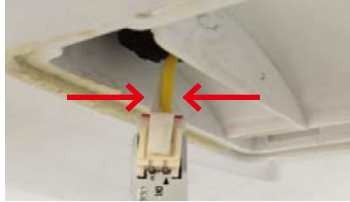

5 Explain to customer



Trouble Shooting

Freezer room upper lamp doesn't work

Symptom	Check Point
1. Freezer room lamp doesn't work	1. Check the Freezer door switch sticky 2. Check the door S/W resistance 3. Check the LED Lamp

FU LED PCB

<table border="1" style="width: 100%;"> <tr> <td style="width: 10%;">1</td><td style="width: 10%;">WH/RD</td><td rowspan="3">C-FAN MOTOR (PWM) MOTEUR DE VENTILATEUR C (CC SANS BALAI)</td></tr> <tr> <td>2</td><td>GY</td></tr> <tr> <td>3</td><td>GY/RD</td></tr> <tr> <td>4</td><td>PK</td><td rowspan="3">F-FAN MOTOR (PWM) MOTEUR DE VENTILATEUR F (CC SANS BALAI)</td></tr> <tr> <td>5</td><td>BO</td></tr> <tr> <td>6</td><td>PR</td></tr> <tr> <td>7</td><td>GY/WH</td><td rowspan="3">ICING-FAN MOTOR (PWM) MOTEUR DE VENTILATEUR GIVRAGE (CC SANS BALAI)</td></tr> <tr> <td>8</td><td>BO/BL</td></tr> <tr> <td>9</td><td>RD/YL</td></tr> <tr> <td>10</td><td>BN/WH</td><td rowspan="3">FU LED LAMP</td></tr> <tr> <td>11</td><td>YL/WH</td></tr> <tr> <td>12</td><td>YL/BK</td></tr> <tr> <td>13</td><td>BK</td><td></td></tr> <tr> <td>14</td><td>SB/WH</td><td></td></tr> <tr> <td>15-16</td><td></td><td></td></tr> </table>	1	WH/RD	C-FAN MOTOR (PWM) MOTEUR DE VENTILATEUR C (CC SANS BALAI)	2	GY	3	GY/RD	4	PK	F-FAN MOTOR (PWM) MOTEUR DE VENTILATEUR F (CC SANS BALAI)	5	BO	6	PR	7	GY/WH	ICING-FAN MOTOR (PWM) MOTEUR DE VENTILATEUR GIVRAGE (CC SANS BALAI)	8	BO/BL	9	RD/YL	10	BN/WH	FU LED LAMP	11	YL/WH	12	YL/BK	13	BK		14	SB/WH		15-16			<table border="1" style="width: 100%;"> <thead> <tr> <th colspan="2"></th> <th colspan="2">S/W Resistance [Ω]</th> </tr> </thead> <tbody> <tr> <td rowspan="2">Door</td> <td>Open</td> <td colspan="2">Infinity</td> </tr> <tr> <td>Closed</td> <td colspan="2">0</td> </tr> </tbody> </table> <table border="1" style="width: 100%;"> <thead> <tr> <th colspan="2"></th> <th>Voltage [V]</th> </tr> </thead> <tbody> <tr> <td>CON3</td> <td>14th Pin ~ 13th Pin</td> <td>12V</td> </tr> </tbody> </table> <table border="1" style="width: 100%;"> <thead> <tr> <th>F-Door</th> <th>LED Lamp</th> <th>Voltage [V]</th> </tr> </thead> <tbody> <tr> <td>Open</td> <td>White ~ Black</td> <td>12V</td> </tr> <tr> <td>Close</td> <td>White ~ Black</td> <td>0~2V</td> </tr> </tbody> </table>			S/W Resistance [Ω]		Door	Open	Infinity		Closed	0				Voltage [V]	CON3	14 th Pin ~ 13 th Pin	12V	F-Door	LED Lamp	Voltage [V]	Open	White ~ Black	12V	Close	White ~ Black	0~2V
1	WH/RD	C-FAN MOTOR (PWM) MOTEUR DE VENTILATEUR C (CC SANS BALAI)																																																														
2	GY																																																															
3	GY/RD																																																															
4	PK	F-FAN MOTOR (PWM) MOTEUR DE VENTILATEUR F (CC SANS BALAI)																																																														
5	BO																																																															
6	PR																																																															
7	GY/WH	ICING-FAN MOTOR (PWM) MOTEUR DE VENTILATEUR GIVRAGE (CC SANS BALAI)																																																														
8	BO/BL																																																															
9	RD/YL																																																															
10	BN/WH	FU LED LAMP																																																														
11	YL/WH																																																															
12	YL/BK																																																															
13	BK																																																															
14	SB/WH																																																															
15-16																																																																
		S/W Resistance [Ω]																																																														
Door	Open	Infinity																																																														
	Closed	0																																																														
		Voltage [V]																																																														
CON3	14 th Pin ~ 13 th Pin	12V																																																														
F-Door	LED Lamp	Voltage [V]																																																														
Open	White ~ Black	12V																																																														
Close	White ~ Black	0~2V																																																														



Trouble Shooting

Freezer room upper lamp doesn't work

1
Check the Freezer door switch.
Does it feel sticky?

Yes → Change the Door S/W



No → 2

2
Check the door S/W resistance.
Is it correct compared with table?

No → Change the Door S/W



Door S/W

		S/W Resistance [Ω]	
Door	Open	Infinity	
	Closed	0	

Yes → 3

3
Check the PCB Voltage.
Is CON3 14th Pin ~ 13th Pin
Voltage 12V?

No → Change the PCB



	Voltage [V]
CON3 14 th Pin ~ 13 th Pin	12V

Yes → 4

4
Check the LED Lamp voltage.
Is voltage 12V? (While door
opened)

No → Change the LED Lamp



Yes → 5

5
Explain to customer



Trouble Shooting

Poor cooling in Fresh food section

Symptom	Check Point
1. Poor cooling in Fresh food section	1. Check the sensor resistance 2. Check the air flow 3. Check the air Temperature 4. Check the R-Damper motor voltage

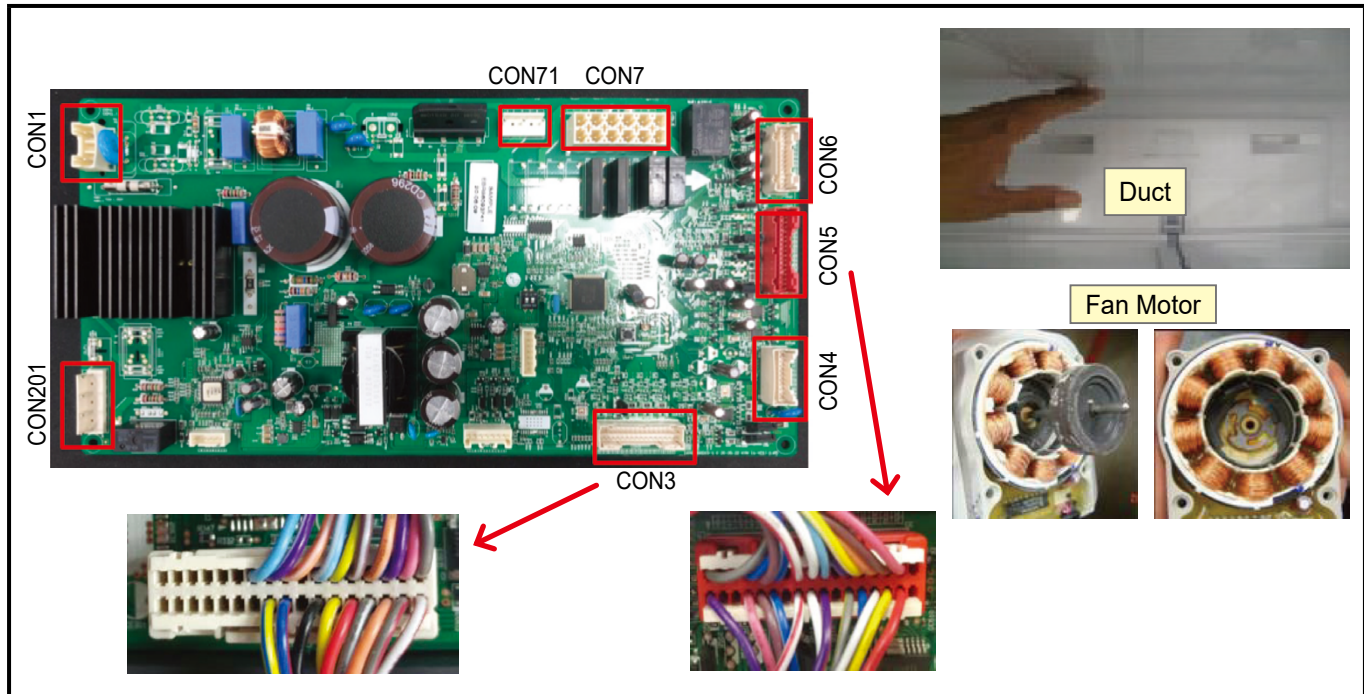

	<table border="1" style="width: 100%;"> <thead> <tr> <th>CON5 18nd Pin ~ 17st Pin</th> <th>Resistance [Ω]</th> </tr> </thead> <tbody> <tr> <td>23°F / -5°C</td> <td>38k</td> </tr> <tr> <td>32°F / 0°C</td> <td>30k</td> </tr> <tr> <td>41°F / 5°C</td> <td>24k</td> </tr> <tr> <td>50°F / 10°C</td> <td>19.5k</td> </tr> <tr> <td>59°F / 10°C</td> <td>16k</td> </tr> </tbody> </table> <table border="1" style="width: 100%;"> <thead> <tr> <th>TEST MODE 1</th> <th>Voltage [V]</th> </tr> </thead> <tbody> <tr> <td>CON3 8th Pin ~ 5th Pin</td> <td>12V</td> </tr> <tr> <td>CON3 6th Pin ~ 5th Pin</td> <td>0V<Voltage<5V</td> </tr> <tr> <td>CON3 7th Pin ~ 5th Pin</td> <td>0V<Voltage<5V</td> </tr> </tbody> </table> <table border="1" style="width: 100%;"> <thead> <tr> <th>Duct</th> <th>Status</th> </tr> </thead> <tbody> <tr> <td>Air Flow</td> <td>Windy</td> </tr> <tr> <td>Air Temperature</td> <td>Cold</td> </tr> </tbody> </table>	CON5 18 nd Pin ~ 17 st Pin	Resistance [Ω]	23°F / -5°C	38k	32°F / 0°C	30k	41°F / 5°C	24k	50°F / 10°C	19.5k	59°F / 10°C	16k	TEST MODE 1	Voltage [V]	CON3 8 th Pin ~ 5 th Pin	12V	CON3 6 th Pin ~ 5 th Pin	0V<Voltage<5V	CON3 7 th Pin ~ 5 th Pin	0V<Voltage<5V	Duct	Status	Air Flow	Windy	Air Temperature	Cold
CON5 18 nd Pin ~ 17 st Pin	Resistance [Ω]																										
23°F / -5°C	38k																										
32°F / 0°C	30k																										
41°F / 5°C	24k																										
50°F / 10°C	19.5k																										
59°F / 10°C	16k																										
TEST MODE 1	Voltage [V]																										
CON3 8 th Pin ~ 5 th Pin	12V																										
CON3 6 th Pin ~ 5 th Pin	0V<Voltage<5V																										
CON3 7 th Pin ~ 5 th Pin	0V<Voltage<5V																										
Duct	Status																										
Air Flow	Windy																										
Air Temperature	Cold																										



Trouble Shooting

Poor cooling in Fresh food section

1 Check the sensor resistance.



CON5 18 th Pin ~ 17 th Pin	Resistance [Ω]
23°F / -5°C	38k
32°F / 0°C	30k
41°F / 5°C	24k
50°F / 10°C	19.5k
59°F / 15°C	16k

2 Reset the unit and Input Test1 Mode.
(Push the button 1 time)



3 Open the fresh food door and Check the air flow Damper?



No
Check the damper
Go to 5

Test Mode	Damper state	SVC Action
1 Mode	Closed	Damper is normal. (Go to the 7)
2 Mode	Open	
1, 2 Mode	Not working	Change the damper

Test Point	Result	SVC Action
(1) To (2)	270 ~ 330 Ω	It's normal
	Other	Change damper
(3) To (4)	270 ~ 330 Ω	It's normal
	Other	Change damper



Yes

4 Check the air temperature.
Is it cold?

No

Check the Compressor and sealed system

Yes

Go to 7

5 Check the Fan Motor voltage.
Is Fan Motor voltage right?

No

Replace Main PCB



TEST MODE 1	Voltage [V]
CON3 8 th Pin ~ 5 th Pin	12V
CON3 7 th Pin ~ 5 th Pin	0V<Voltage<5V

Yes

6 Check the Fan Motor voltage.
Is Fan Feed Back voltage 0V, 5V?

Yes

Change the motor



TEST MODE 1	Voltage [V]
CON3 6 th Pin ~ 5 th Pin	0V<Voltage<5V

No

7 Explain to customer



Trouble Shooting

Poor cooling in Freezer compartment

Symptom	Check Point
1. Poor cooling in Freezer compartment	1. Check the sensor resistance 2. Check the air flow 3. Check the air Temperature 4. Check the Fan motor sticky 5. Check the Fan motor voltage

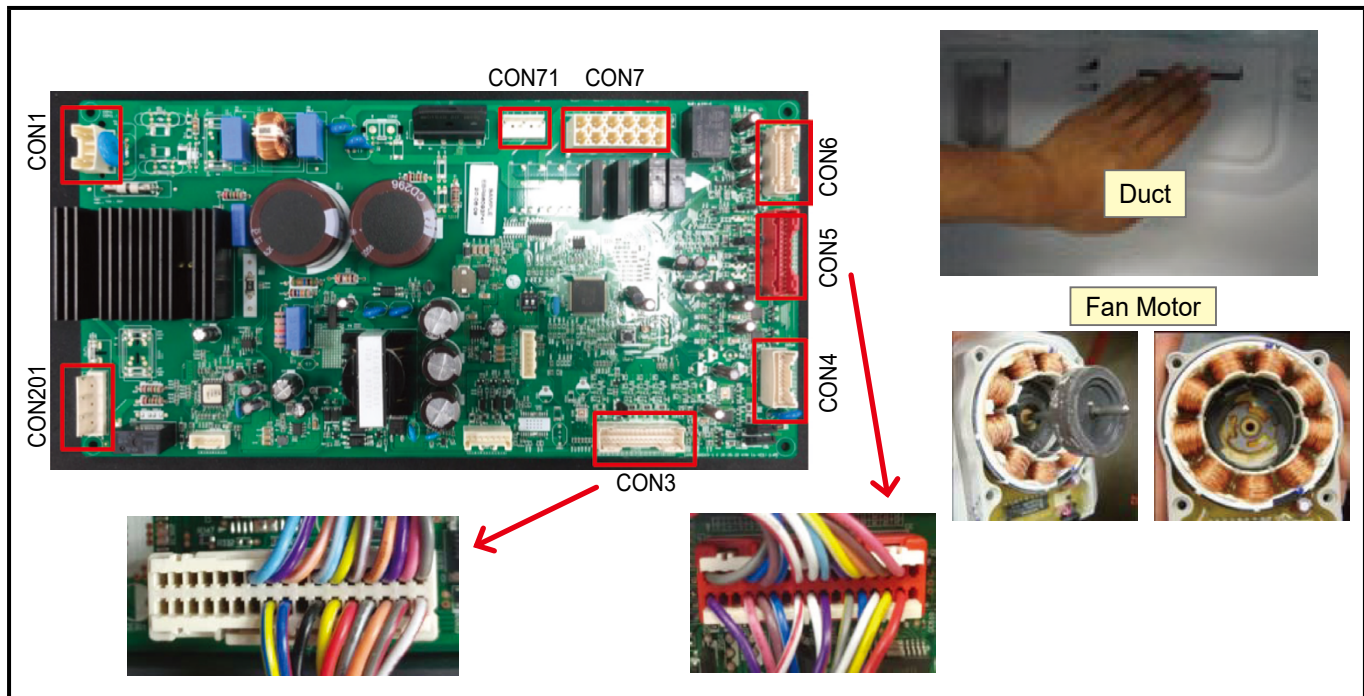

The wiring diagram shows connections for various components. The F-FAN MOTOR (pins 5-7) and F-SENSOR (pins 11-12) are highlighted with red boxes. Other components include C-FAN MOTOR (pins 1-4), ICING-FAN MOTOR (pins 9-14), FU LED LAMP (pins 1-2), R-ROOM LED MODULE (pins 7-10), PANTRY-SENSOR (pins 15-16), and R-SENSOR (pins 17-18).

CON5 12 th Pin ~ 11 th Pin	Resistance [Ω]
-22°F / -30°C	40k
-13°F / -25°C	30k
-4°F / -20°C	23k
5°F / -15°C	17k
14°F / -10°C	13k
23°F / -5°C	10k
32°F / 0°C	8k

TEST MODE 1	Voltage [V]
CON3 8 th Pin ~ 5 th Pin	12V
CON3 6 th Pin ~ 5 th Pin	0V<Voltage<5V
CON3 7 th Pin ~ 5 th Pin	0V<Voltage<5V

Duct	Status
Air Flow	Windy
Air Temperature	Cold



Trouble Shooting

Poor cooling in Freezer compartment

1

Check the sensor resistance.

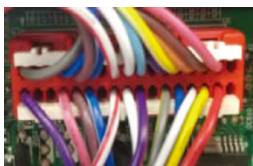

CON7 17 nd Pin ~ 20 st Pin	Resistance [Ω]
-22°F / -30°C	40k
-13°F / -25°C	30k
-4°F / -20°C	23k
5°F / -15°C	17k
14°F / -10°C	13k
23°F / -5°C	10k
32°F / 0°C	8k

2

Reset the unit and Input Test1 Mode.
(Push the button 1 time)



3

Open the fresh food door and
Check the air flow. Windy?



Check the
Fan Motor
Go to 5

4

Check the air temperature.
Is it cold?

No

Check the
Compressor
and sealed
system

Yes

5

Check the Fan Motor.
Rotate fan using hand.
It feel sticky?

Yes

Change the
Fan motor

Fan Motor

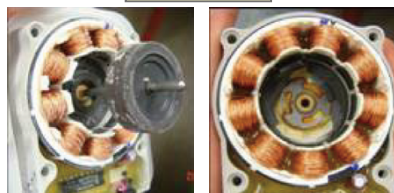

No



Trouble Shooting

6

Check the Fan Motor voltage.
Is Fan Motor voltage right?



TEST MODE 1	Voltage [V]
CON3 8 th Pin ~ 5 th Pin	12V
CON3 7 th Pin ~ 5 th Pin	0V<Voltage<5V

No → Replace Main PCB

Yes

7

Check the Fan Motor voltage.
Is Fan Feed Back voltage right?



TEST MODE 1	Voltage [V]
CON3 6 th Pin ~ 5 th Pin	0V<Voltage<5V

No → Change the motor

Yes

8

Explain to customer



Trouble Shooting

Wi-Fi Modem doesn't work

Symptom	Check Point
1. Wi-Fi modem doesn't work	1. Check connector 2. Display PCB 3. Wi-Fi modem PCB

Display PCB

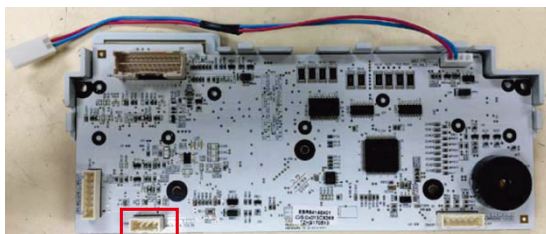

CON802

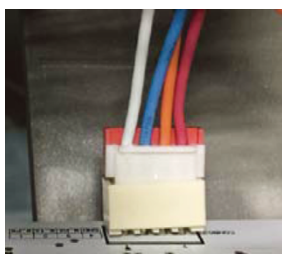

CON802

Wi-Fi PCB

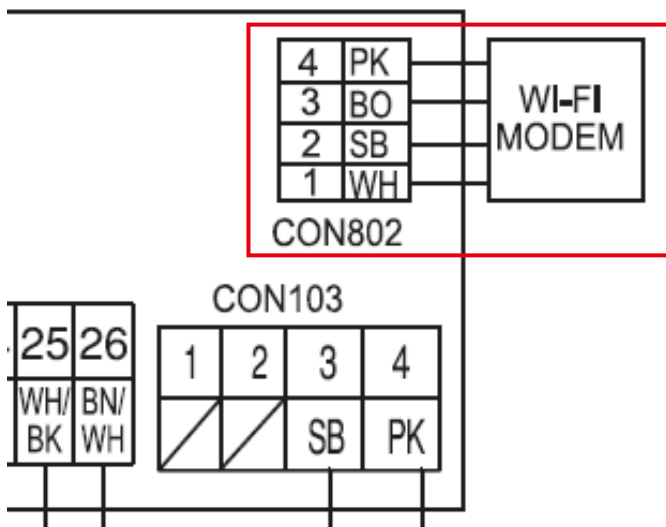

Wi-Fi ON	Voltage [V]
CON802 1 st Pin ~ 4 th Pin	5V
CON802 2 nd Pin ~ 4 th Pin	Not 0V, 5V
CON802 3 rd Pin ~ 4 th Pin	Not 0V, 5V



Trouble Shooting

Wi-Fi modem doesn't work

1
Choose the connectors in the display and lead wire.
Is it loose?

Yes → Connect the housing

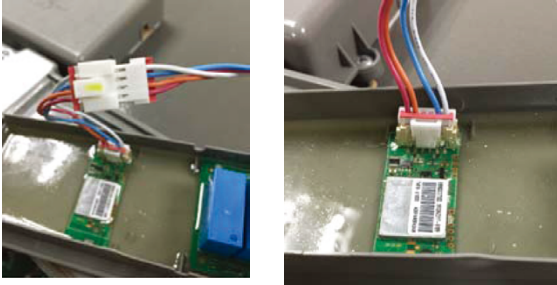

No → [Next Step]

2
Check the Wi-Fi PCB output?
(While Wi-Fi function is on)

No → Change Wi-Fi modem

Wi-Fi modem	Voltage [V]
5 th Pin ~ 6 th Pin	Not 0V, 5V



Yes → [Next Step]

3
Check the Display PCB output?
(While Wi-Fi function is on)

No → Change the display

Display CON802	Voltage [V]
1 st Pin ~ 4 th Pin	5V
2 nd Pin ~ 4 th Pin	Not 0V, 5V

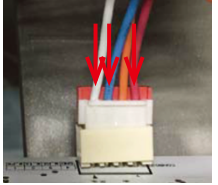

CON802

Yes → [Next Step]

4
Explain to the customer



Trouble Shooting

Freezer I/Maker Error (E IU)

Symptom	Check Point
1. E IU	1. Check for a loose connection 2. Check heater resistance

1. Harvest Failure

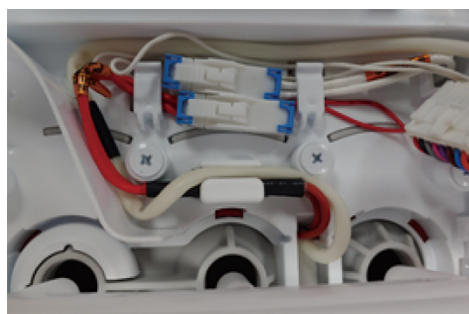

	Resistance
Upper HTR (Red)	14.1 ~ 16.3 Ω

2. Ice making Failure

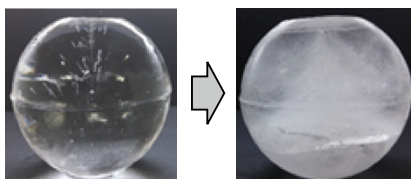

More cloudy ice



Shape like lump on ice

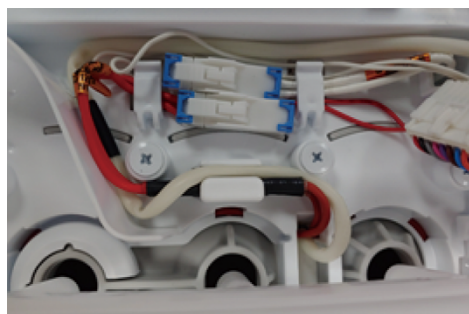

	Resistance
Lower HTR (White)	14.1 ~ 16.3 Ω



Trouble Shooting

High/Low side Cycle leakage(Refrigerant leak or Sealed system problem) Error (E CH/E CL)

• Error CH or CL might be detected by refrigerant leak, sealed system, etc. Please follow smart svc process.

Symptom	Check Point
<p>E CH (No cooling)</p> <p>※ This logic might be detected by high side refrigerant leak, restriction, bad comp, bad valve, etc.</p>	<p>① The LG Refrigerator displays an error code on the display for sealed system problem. Through this error code(E CH or E CL), please follow svc process.</p> <p>② Through Step1 using SVC App, you can know it is compressor or sealed system problem, or you can know it is normal (customer's emotional fault). If you have no SVC App jig, please check temperature using temperature gun.</p> <p>③ You check voltage to know whether it is a PCB problem or not.</p> <p>④ By checking the return time to the equilibrium pressure after measuring the pressure of the high pressure part (drier) and the low pressure part (comp processing pipe) of the sealed system, You can find sealed system is blocked or not. When there is clogging, it takes long time (15min ↑) to return to the equilibrium pressure.</p> <p>⑤ By checking equilibrium pressure, it is confirmed that there is sufficient refrigerant in the sealed system. Then it can be know that cause of "Not cooling" is whether compressor fault or sealed system leak.</p> <p>⑥ In case of leak of sealed system, leak test is carried out using refrigerant or nitrogen.</p> <p>⑦ Check the leak of high-pressure parts (Condenser, Drier, etc.).</p> <p>⑧ If there is no leak of high-pressure parts, Check the leak of low pressure parts (Evaporator, Suction pipe, etc.)</p> <p>⑨ After sealed system repair, when freezer temperature is 14°F↓, the error code will disappear automatically. Check the leak using UV Drier (for next visit)</p>

Symptom	Check Point
<p>E CL (No cooling)</p> <p>※ This logic might be detected by low side refrigerant leak, bad comp, long time door open, etc.</p>	<p>① The LG Refrigerator displays an error code on the display for sealed system problem. Through this error code (E CH or E CL), please follow svc process.</p> <p>② Through Step1 using SVC App, you can know it is compressor or sealed system problem, or you can know it is normal (customer's emotional fault). If you have no SVC App jig, please check temperature using temperature gun.</p> <p>③ You check voltage to know whether it is a PCB problem or not.</p> <p>④ By checking the return time to the equalized pressure after measuring the pressure of the high pressure part (drier) and the low pressure part (comp processing pipe) of the sealed system, You can find sealed system is blocked or not. When there is clogging, it takes long time (15min ↑) to return to the equalized pressure.</p> <p>⑤ By checking equalized pressure, it is confirmed that there is sufficient refrigerant in the sealed system. Then it can be know that cause of "Not cooling" is whether compressor fault or sealed system leak.</p> <p>⑥ In case of leak of sealed system, leak test is carried out using refrigerant or nitrogen.</p> <p>⑦ Check the leak of low-pressure parts (Evaporator, Suction pipe, etc.)</p> <p>⑧ If there is no leak of low-pressure parts, Check the leak of high-pressure parts (Condenser, Drier, etc.).</p> <p>⑨ After sealed system repair, when freezer temperature is 14°F↓, the error code will disappear automatically. Check the leak using UV Drier (for next visit)</p>

※ Freezer temperature is 14 °F↓ (After a day of SVC) the error code (E CH, E CL) disappears.
But, If temperature(sealed system) is normal and Error CH or CL displays continuously, please press error forced deletion button.

※ Error(CH or CL) forced deletion button(*Customer complaint rise and algorithm problem etc.)
F key + R key(3times) with the door open



Trouble Shooting

Error CH, CL SVC Process

1. E CH : No Cooling

(High side refrigerant leak, Restriction, Bad comp, Bad valve, etc.)

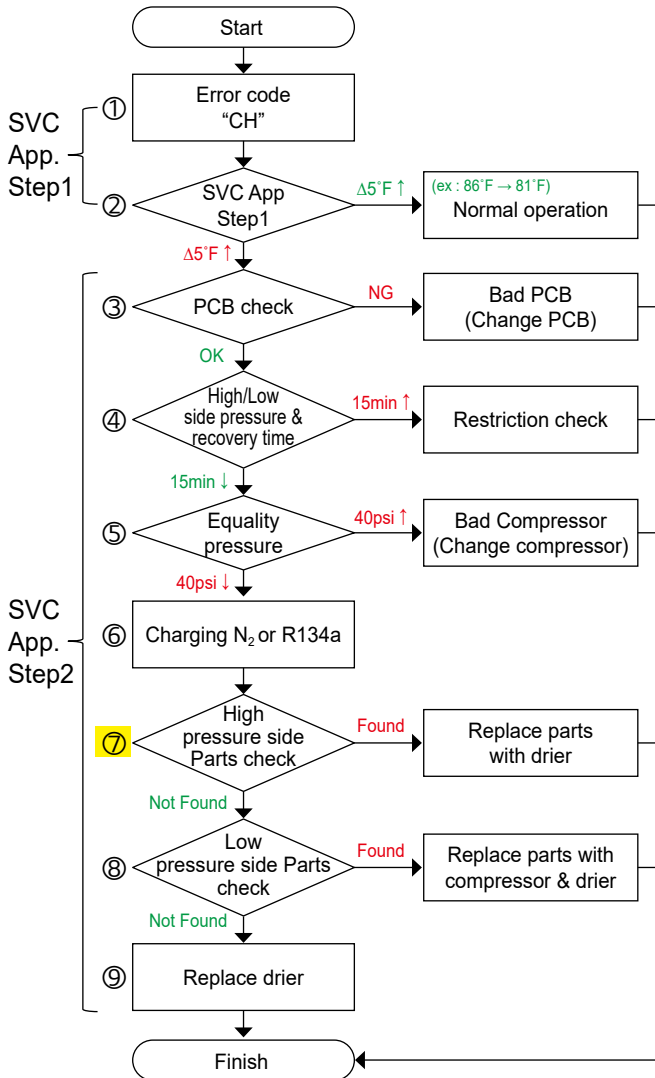

2. E CL : No Cooling

(Low side refrigerant leak, Bad comp, Long time door open, etc.)

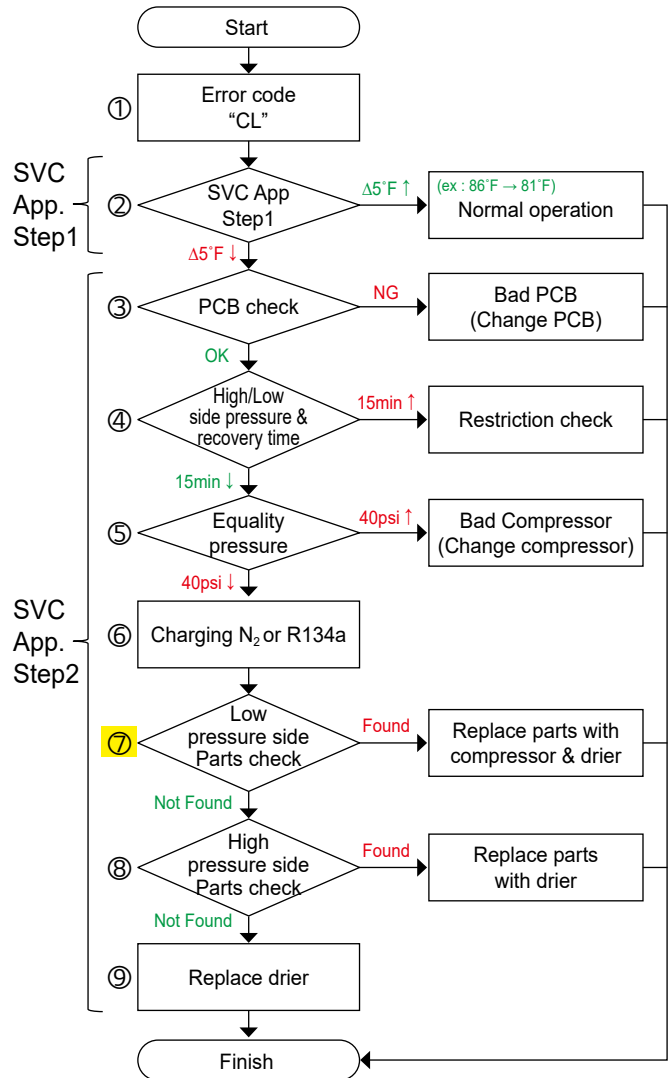



Trouble Shooting

Communication Error(Sd E)

Symptom	Check Point
1. Sd E	1. Check the loose connection

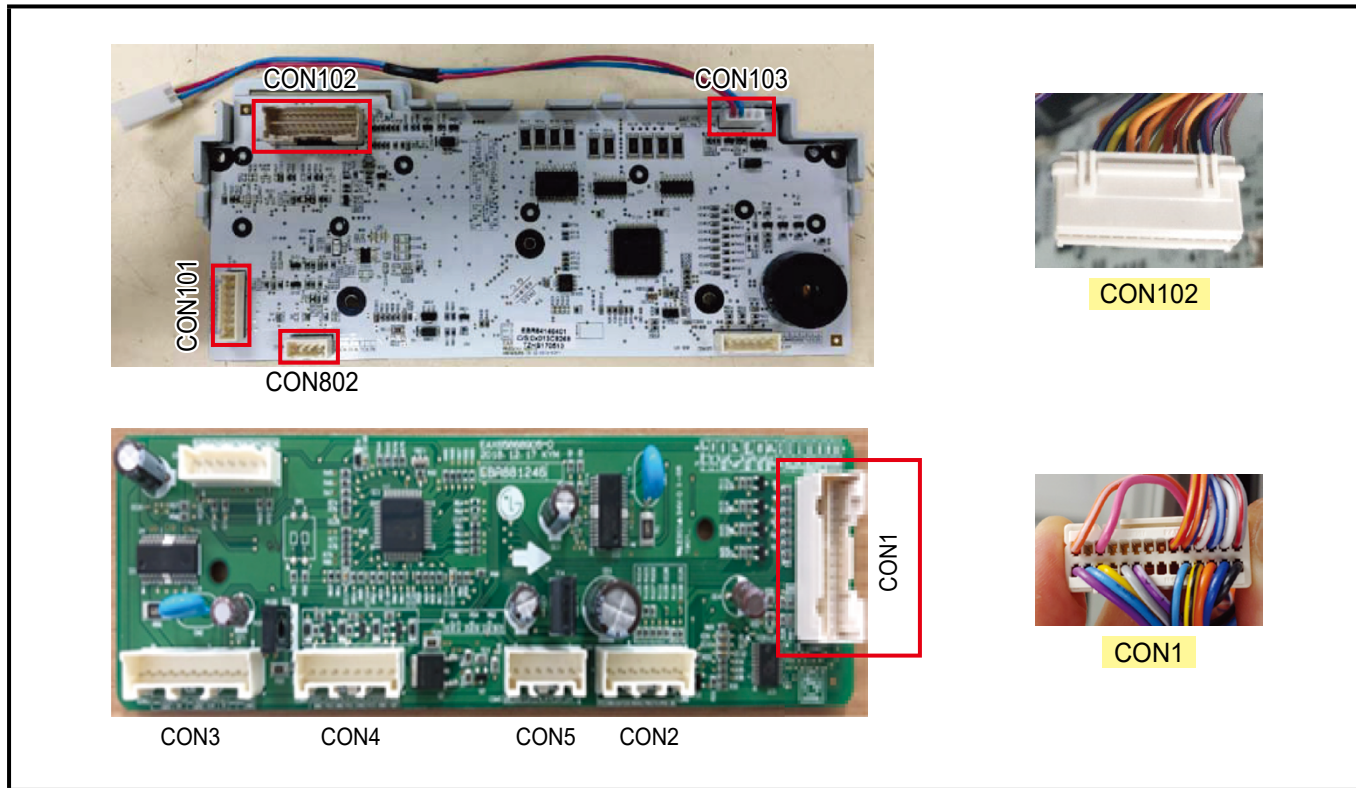

Display CON102

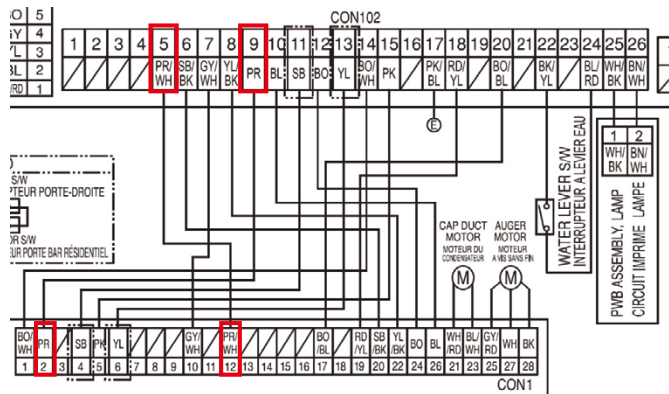

Sub CON1

	Voltage [V]
CON102 3 rd Pin ~ 5 th Pin	Not 0V, 5V
CON102 3 rd Pin ~ 9 th Pin	Not 0V, 5V
CON1 2 nd Pin ~ CON5 6 th Pin	Not 0V, 5V
CON1 12 th Pin ~ CON5 6 th Pin	Not 0V, 5V



Trouble Shooting

Communication Error(Sd E)

1
Check the loose connection

No

2
Check the voltage.
Is CON102 3rd Pin ~ 5th Pin
voltage 0V or 5V?

Yes

Change the
Display PCB

Housing	Voltage [V]
CON102 3 rd Pin ~ 5 th Pin	Not 0V, 5V



No

3
Check the voltage.
Is CON102 3rd Pin ~ 9th Pin
voltage 0V or 5V?

Yes

Change the
Sub PCBA

Housing	Voltage [V]
CON102 3 rd Pin ~ 9 th Pin	Not 0V, 5V



No

4
Check the voltage.
Is CON1 12th Pin ~ CON5 6th Pin
voltage 0V or 5V?

Yes

Change the
Display PCB

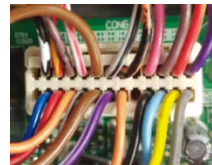

Housing	Voltage [V]
CON1 12 th Pin ~ CON5 6 th Pin	Not 0V, 5V

No

5
Check the voltage.
Is CON1 2nd Pin ~ CON5 6th Pin
voltage 0V or 5V?

Yes

Change the
Sub PCBA



Housing	Voltage [V]
CON1 2 nd Pin ~ CON5 6 th Pin	Not 0V, 5V

No

6
Explain to the customer



Reference

TEST MODE and Removing TPA

1. How to enter the TEST MODE

Push the test button on the Main PCB to enter the TEST MODE.

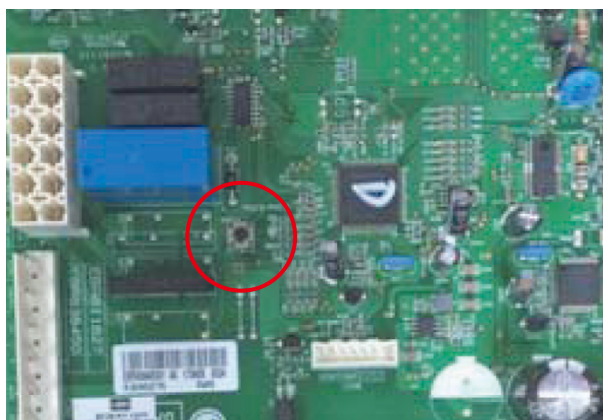

Main PWB

*** 1 time : Comp / Damper / All FAN on
(All things displayed)**



*** 2 times : Damper closed
(22 22 displayed)**



*** 3 times : Forced defrost mode
(33 33 displayed)**



2. How to remove Terminal Position Assurance (TPA)

<AC TPA>

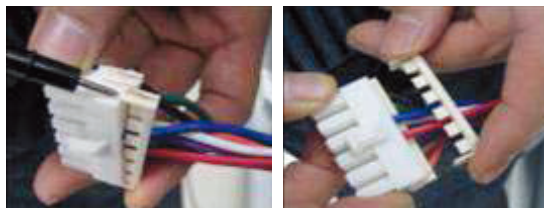

<DC TPA>



※ After measure the values, you should put in the TPA again.



Reference

TEMPERATURE CHART - FRZ AND ICING SENSOR

TEMP	RESISTANCE	VOLTAGE
-39°F (-40°C)	73.29 kΩ	4.09 V
-30°F (-35°C)	53.63 kΩ	3.84 V
-21°F (-30°C)	39.66 kΩ	3.55 V
-13°F (-25°C)	29.62 kΩ	3.23 V
-4°F (-20°C)	22.33 kΩ	2.89 V
5°F (-15°C)	16.99 kΩ	2.56 V
14°F (-10°C)	13.05 kΩ	2.23 V
23°F (-5°C)	10.10 kΩ	1.92 V
32°F (0°C)	7.88 kΩ	1.63 V
41°F (5°C)	6.19 kΩ	1.38 V
50°F (10°C)	4.91 kΩ	1.16 V
59°F (15°C)	3.91 kΩ	0.97 V
68°F (20°C)	3.14 kΩ	0.81 V
77°F (25°C)	2.54 kΩ	0.67 V
86°F (30°C)	2.07 kΩ	0.56 V
95°F (35°C)	1.69 kΩ	0.47 V
104°F (40°C)	1.39 kΩ	0.39 V



Reference

TEMPERATURE CHART - REF AND DEF SENSOR

TEMP	RESISTANCE	VOLTAGE
-39°F (-40°C)	225.1 kΩ	4.48 V
-30°F (-35°C)	169.8 kΩ	4.33 V
-21°F (-30°C)	129.3 kΩ	4.16 V
-13°F (-25°C)	99.30 kΩ	3.95 V
-4°F (-20°C)	76.96 kΩ	3.734 V
5°F (-15°C)	60.13 kΩ	3.487 V
14°F (-10°C)	47.34 kΩ	3.22 V
23°F (-5°C)	37.55 kΩ	2.95 V
32°F (0°C)	30 kΩ	2.67 V
41°F (5°C)	24.13 kΩ	2.40 V
50°F (10°C)	19.53 kΩ	2.14 V
59°F (15°C)	15.91 kΩ	1.89 V
68°F (20°C)	13.03 kΩ	1.64 V
77°F (25°C)	10.74 kΩ	1.45 V
86°F (30°C)	8.89 kΩ	1.27 V
95°F (35°C)	7.40 kΩ	1.10 V
104°F (40°C)	6.20 kΩ	0.96 V



Reference

How to check the Fan-Error

After sending a signal to the fan, the MICOM checks the BLDC fan motor's lock status. If there is no feedback signal from the BLDC fan, the fan motor stops for 10 seconds and then is powered again for 15 seconds. To determine that there is a fan motor malfunction, this process is repeated 3 times. If the fan motor is determined to be defective, the error code will be shown in the display for 30 minutes.

At this point, the process will be repeated until the fan motor operates normally. If normal operation is achieved, the error display is erased and the MICOM is reset automatically.

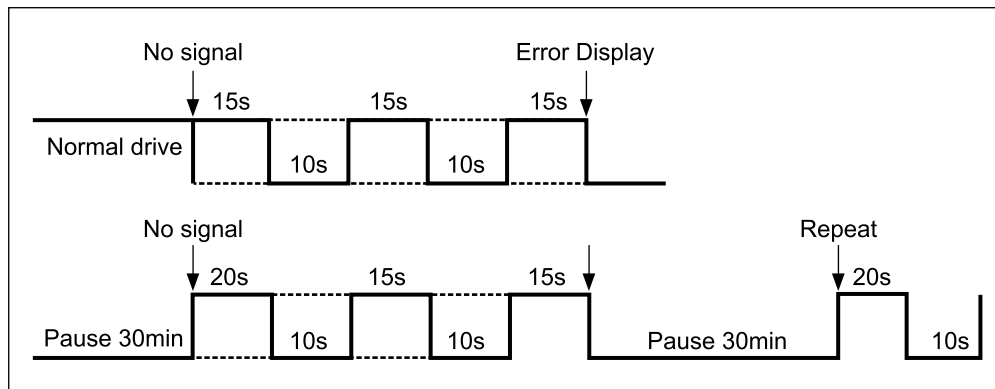



Component Testing Information

Defrost Controller Assembly

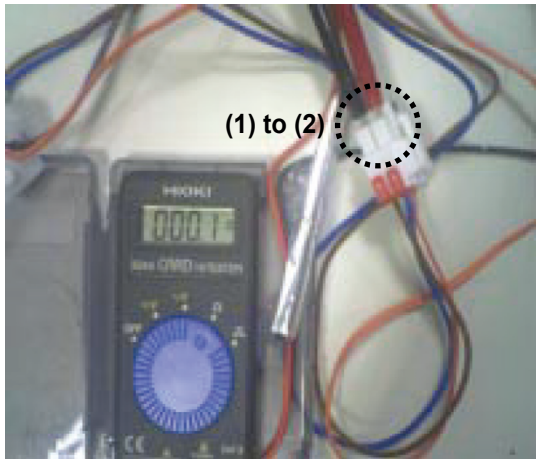
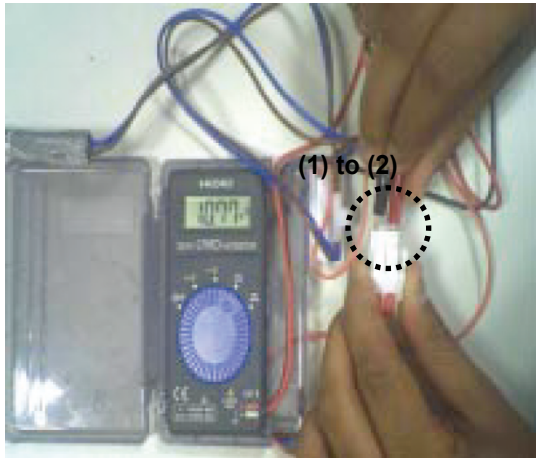
Function	The controller assembly is made up of two different kinds of parts. The fuse and the sensor. To determine if these parts are defective, check for resistance. The fuse will cut power to the defrost heater at very high temperatures.					
How to Measure (Fuse-M)		Set a ohmmeter to the 2 housing pin. Measure the 2 pin connected to Fuse-M. If the ohmmeter indicate below 0.1 ohm fuse-m is a good condition, But if infinite the part is bad.				
How to Measure (Sensor)		Set a ohmmeter to The 2housing pin. Measure the 2 pin connected to Sensor. If the ohmmeter indicate 11 kΩ (at room temperature) Sensor is good. When check the ohm at other temperatures Check the sensor manual.				
Standard	<p style="text-align: center;">Sensor (at room temperature)</p> <table border="1" style="margin-left: auto; margin-right: auto;"> <thead> <tr> <th>Test Point</th> <th>Result</th> </tr> </thead> <tbody> <tr> <td>(1) to (2)</td> <td>11 kΩ</td> </tr> </tbody> </table>		Test Point	Result	(1) to (2)	11 kΩ
Test Point	Result					
(1) to (2)	11 kΩ					



Component Testing Information

Sheath Heater

Function	Sheath heater is the part for defrost. All heating wire is connected to only one line. To check if the part is defective, check the resistance.				
How to Measure	<div data-bbox="391 474 917 888"></div> <div data-bbox="993 474 1435 888"></div> <p data-bbox="354 1026 1073 1205">Set a ohmmeter connect to The 2 housing pins. Measure the 2 pins connected to Sheath Heater. If the ohmmeter indicates $(V^{\circ}\theta V)/Watt=R$ is on a good condition, ex) when watt=350w, voltage=115v $R=(115^{\circ}\theta 115)/350=38 \Omega$ But if the ohm meter indicate infinity the Sheath heater is bad.</p>				
Standard	<p data-bbox="386 1249 789 1278">Sheath heater (at all temperature)</p> <table border="1" data-bbox="386 1291 839 1390"><thead><tr><th data-bbox="386 1291 613 1339">Test Point</th><th data-bbox="613 1291 839 1339">Result(Ω)</th></tr></thead><tbody><tr><td data-bbox="386 1339 613 1390">(1) to (2)</td><td data-bbox="613 1339 839 1390">34 ~ 42 Ω</td></tr></tbody></table>	Test Point	Result(Ω)	(1) to (2)	34 ~ 42 Ω
Test Point	Result(Ω)				
(1) to (2)	34 ~ 42 Ω				



Component Testing Information

Door Heater Assembly

Function	The heater is designed to prevent the raising dew from door.				
How to Measure					
Standard	<table border="1" data-bbox="388 1251 841 1350"><thead><tr><th data-bbox="388 1251 615 1299">Test Point</th><th data-bbox="615 1251 841 1299">Result(Ω)</th></tr></thead><tbody><tr><td data-bbox="388 1299 615 1350">(1) to (2)</td><td data-bbox="615 1299 841 1350">1.9 ~ 2.2 kΩ</td></tr></tbody></table>	Test Point	Result(Ω)	(1) to (2)	1.9 ~ 2.2 k Ω
Test Point	Result(Ω)				
(1) to (2)	1.9 ~ 2.2 k Ω				



Component Testing Information

Dispenser DC Motor

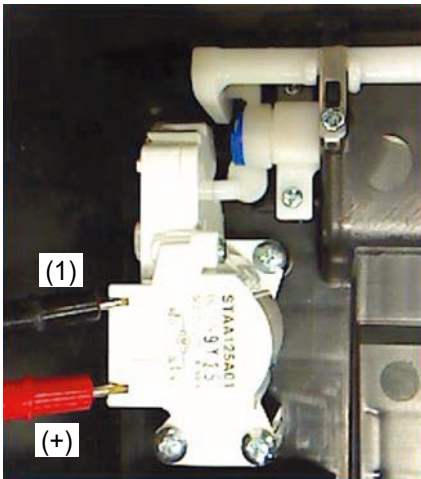
Function	Dispenser DC Motor : When customer push the dispenser button, Pull duct door and abstract from ice bank.				
How to Measure	 <p style="text-align: center;">Dispenser DC Motor</p>				
Standard	Dispenser DC Motor <table border="1" style="margin-left: auto; margin-right: auto;"><thead><tr><th>Test Point</th><th>Result</th></tr></thead><tbody><tr><td>(1) to (2)</td><td>9.9 ~ 12.1 Ω</td></tr></tbody></table>	Test Point	Result	(1) to (2)	9.9 ~ 12.1 Ω
Test Point	Result				
(1) to (2)	9.9 ~ 12.1 Ω				



Component Testing Information

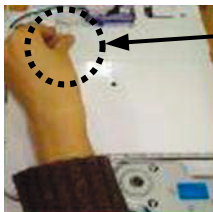
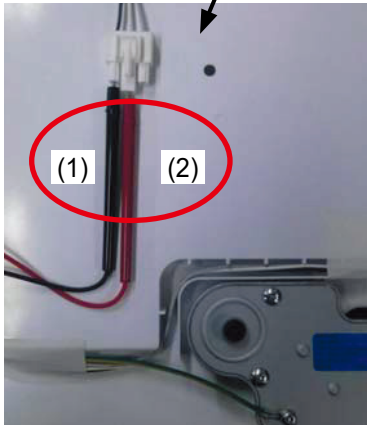
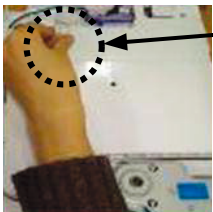
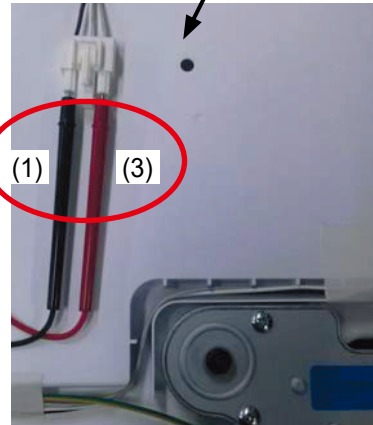

AC Motor ASSEMBLY

Function	The motor in the door pushed the ice into the dispenser.						
How to Measure	<div style="display: flex; justify-content: space-around;"> <div style="text-align: center;"> <p><In-door Motor></p>  <p>① Separate the housing.</p>  <p>② Measure the resistance between (1) and (2)</p> </div> <div style="text-align: center;"> <p><In-door Motor></p>  <p>① Separate the housing.</p>  <p>② Measure the resistance between (1) and (3)</p> </div> </div> <p>Check the resistance between connectors (In-door motor 1, 2) and (In-door motor 1, 3). It means check whether or not applying an Electric current. If there is resistance, it means the geared motor or solenoid is not inferiority</p>						
Standard	<p>Geared Motor</p> <table border="1" data-bbox="386 1352 839 1499"> <thead> <tr> <th>Test Point</th> <th>Result</th> </tr> </thead> <tbody> <tr> <td>(1) to (2)</td> <td>31.1 ~ 42.09 Ω</td> </tr> <tr> <td>(1) to (3)</td> <td>31.1 ~ 42.09 Ω</td> </tr> </tbody> </table>	Test Point	Result	(1) to (2)	31.1 ~ 42.09 Ω	(1) to (3)	31.1 ~ 42.09 Ω
Test Point	Result						
(1) to (2)	31.1 ~ 42.09 Ω						
(1) to (3)	31.1 ~ 42.09 Ω						

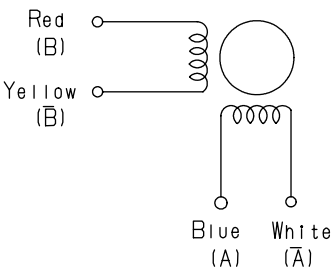
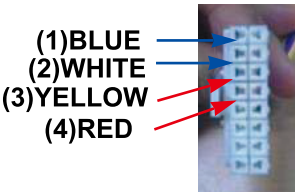
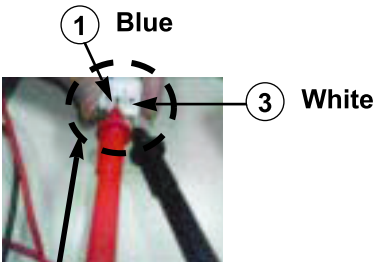

Component Testing Information

Damper

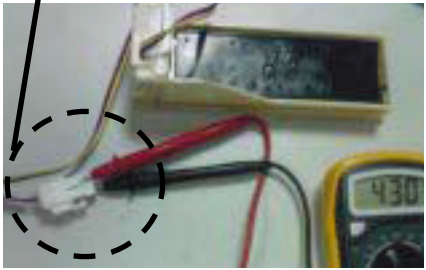
Function	<p>The damper supplies cold air from the freezer to the chill room using the damper plate. The chill room is colder when the damper plate is open. When the damper is closed the chill rooms temperature will rise.</p>																													
How to Measure	<div style="border: 1px dashed black; padding: 10px; margin-bottom: 10px;"> <p style="text-align: center;">Table(1): 결선도(Wiring)</p>  </div> <div style="border: 1px dashed black; padding: 10px; margin-bottom: 10px;"> <p style="text-align: center;">Table(2): 2-2상 여자순서(CW Rotation)</p> <table border="1" style="width: 100%; border-collapse: collapse; text-align: center;"> <thead> <tr> <th rowspan="2">Housing No. & L/Wire Color</th> <th colspan="4">Step</th> </tr> <tr> <th>1</th> <th>2</th> <th>3</th> <th>4</th> </tr> </thead> <tbody> <tr> <td>1- Blue (A)</td> <td>+</td> <td>-</td> <td>-</td> <td>+</td> </tr> <tr> <td>2- Red (B)</td> <td>+</td> <td>+</td> <td>-</td> <td>-</td> </tr> <tr> <td>3- White (A)</td> <td>-</td> <td>+</td> <td>+</td> <td>-</td> </tr> <tr> <td>4- Yellow (B)</td> <td>-</td> <td>-</td> <td>+</td> <td>+</td> </tr> </tbody> </table> </div> <p style="text-align: center;">< Damper Circuit ></p> <div style="display: flex; justify-content: space-around;"> <div style="text-align: center;">  <p>(1)BLUE (2)WHITE (3)YELLOW (4)RED</p> </div> <div style="text-align: center;">  <p>① Blue ③ White</p> <p>Check the ①, ③</p> </div> </div> <p style="text-align: center;">< extension ></p> <div style="display: flex; justify-content: space-around;"> <div style="text-align: center;">  <p>Check the ①, ②</p> </div> <div style="text-align: center;">  <p>Check the ③, ④</p> </div> </div> <p>Check to see if there is electrical current, if there is resistance the damper is good.</p>	Housing No. & L/Wire Color	Step				1	2	3	4	1- Blue (A)	+	-	-	+	2- Red (B)	+	+	-	-	3- White (A)	-	+	+	-	4- Yellow (B)	-	-	+	+
Housing No. & L/Wire Color	Step																													
	1	2	3	4																										
1- Blue (A)	+	-	-	+																										
2- Red (B)	+	+	-	-																										
3- White (A)	-	+	+	-																										
4- Yellow (B)	-	-	+	+																										
Standard	<p>Damper</p> <table border="1" style="display: inline-table; margin-right: 20px;"> <thead> <tr> <th>Test Points</th> <th>Result</th> </tr> </thead> <tbody> <tr> <td>Red and Yellow</td> <td>373 ~ 456 Ω</td> </tr> </tbody> </table> <table border="1" style="display: inline-table;"> <thead> <tr> <th>Test Points</th> <th>Result</th> </tr> </thead> <tbody> <tr> <td>Blue and White</td> <td>373 ~ 456 Ω</td> </tr> </tbody> </table>	Test Points	Result	Red and Yellow	373 ~ 456 Ω	Test Points	Result	Blue and White	373 ~ 456 Ω																					
Test Points	Result																													
Red and Yellow	373 ~ 456 Ω																													
Test Points	Result																													
Blue and White	373 ~ 456 Ω																													



Component Testing Information

Flow Sensor

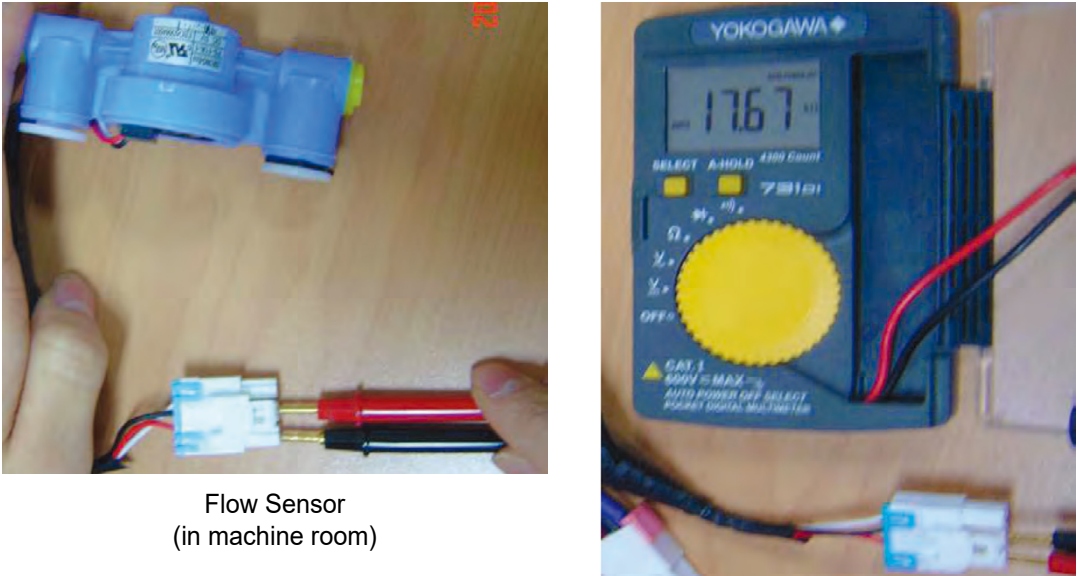
Function	Flow Sensor (in machine room) Count the water quantity from city water to water filter in refrigerator					
How to Measure	 <p data-bbox="548 940 753 999">Flow Sensor (in machine room)</p>					
Standard	<table border="1" data-bbox="386 1056 956 1152"><thead><tr><th data-bbox="386 1056 732 1104">Test Points</th><th data-bbox="732 1056 956 1104">Result</th></tr></thead><tbody><tr><td data-bbox="386 1104 732 1152">Red wire to Black wire</td><td data-bbox="732 1104 956 1152">4 ~ 30 kΩ</td></tr></tbody></table>		Test Points	Result	Red wire to Black wire	4 ~ 30 kΩ
Test Points	Result					
Red wire to Black wire	4 ~ 30 kΩ					



Compressor Troubleshooting

Linear Inverter LED Blinking Troubleshooting

Comp Operation Defect



1. Open the PCBA Cover



2. Check the number of LED blinks
(Refer to the next page for resolution by number of LED blinks)

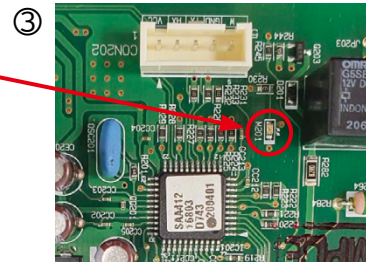

3. When the COMP is normal, it will not blink

If the Comp & Fan is not operated then input the test mode and check the comp condition.
(Operation or not)

- Simple Check Flow Chart

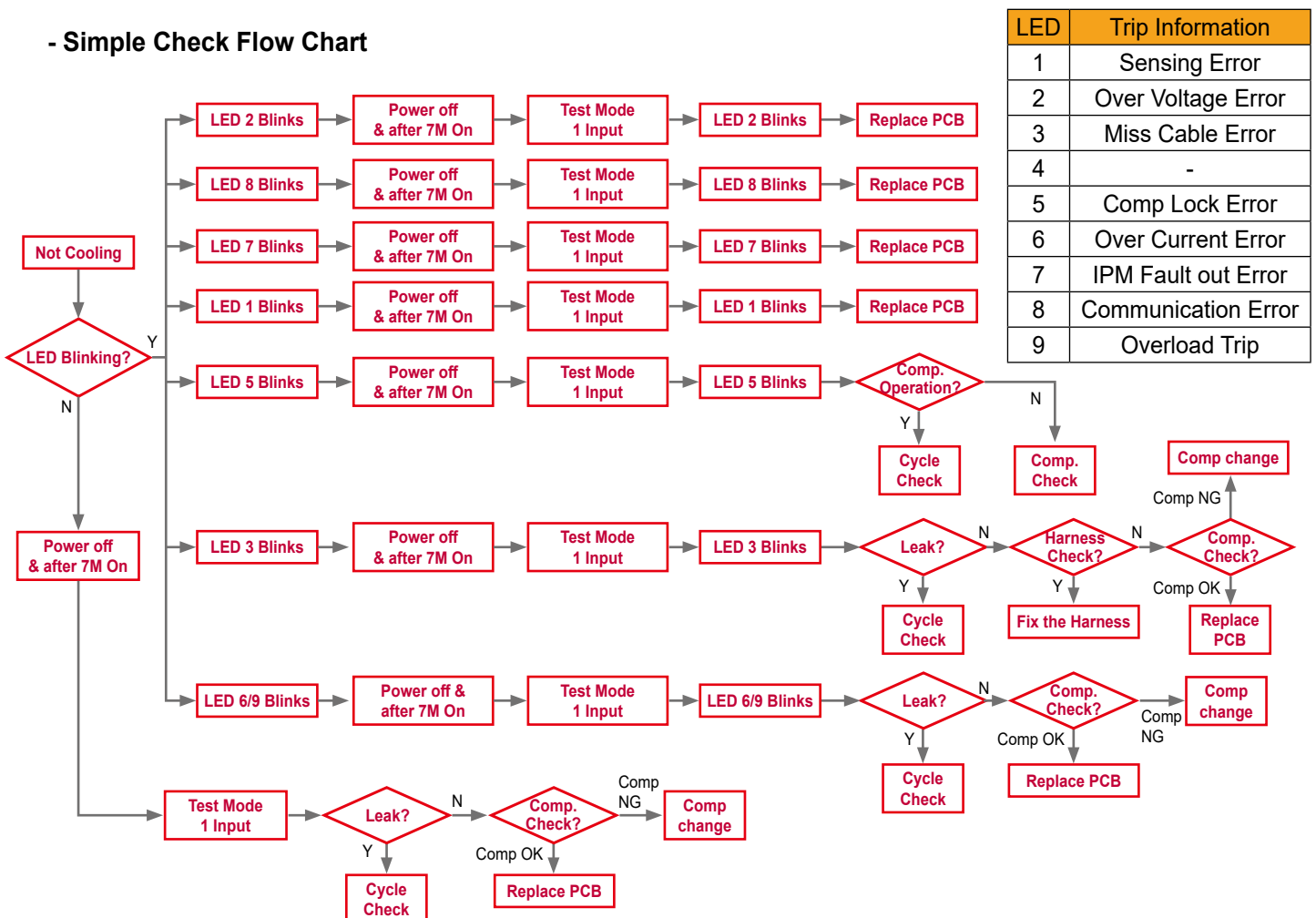



Compressor Troubleshooting

3. Miss Cable Trip & LED 3 blink (Miss Cable Error)

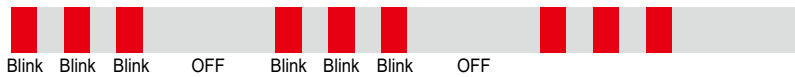

- Purpose : For protection from Miss cable
- Reason : The fault Harness that between PCBA and Comp
- Logic : Comp. Off & restart every 270s

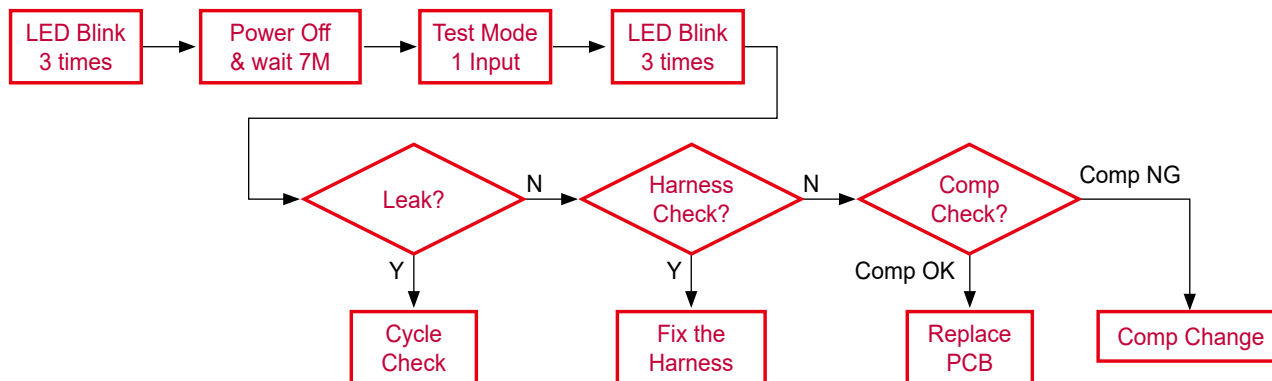

4. Locked Rotor Trip & LED 5 Blink (Locked Rotor)



- Purpose : Check the rotor's locked condition
- Reason : Oil empty in cylinder, damaged cylinder or piston, discharge valve clogged, foreign in the comp inside
- Logic : Comp. Off & restart every 330s

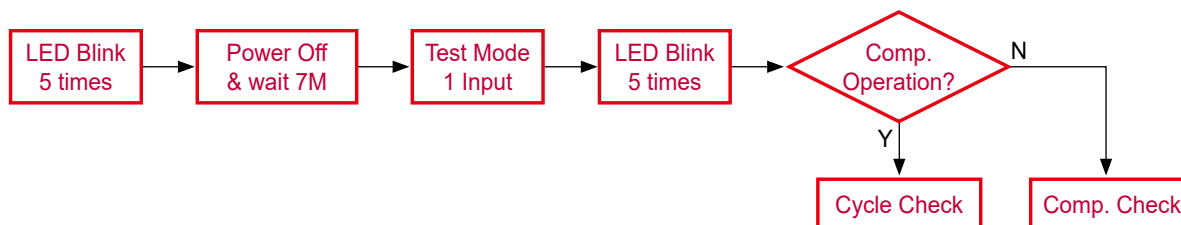



Compressor Troubleshooting

5. Over Current Trip & LED 6 blink (Over Current)



- Purpose : Protection from Over Current
- Reason : High temperature, Environment condition, C-Fan Error, Comp Error, PCBA Error(IPM burnt), etc
- Logic : Comp. Off & restart Every 360s

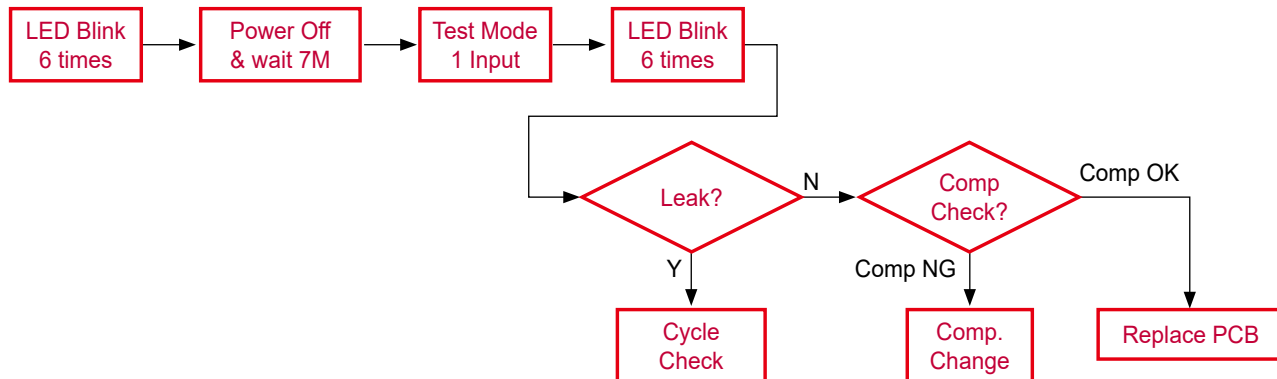

6. IPM Fault Trip & LED 7 blink (IPM Fault)



- Purpose : Protection Over Current that occurred by IPM short or malfunction.
- Reason : IPM Short, malfunction
- Logic : Comp. Off & restart Every 300s





Compressor Troubleshooting

7. Communication Error Trip & LED 8 Blink (Communication Error)



- Purpose : Check the Communication error between Main & Comp Micom
- Reason : Communication error
- Logic : There are no Comp off, just LED blink 8 times(Comp will drive last order from Main Micom)



8. Overload Trip & LED 9 Blink (Overload)



- Purpose : Protection from Overload
- Reason : High temperature, Environment condition, C-Fan Error, Comp Error, PCBA Error(IPM burnt), etc
- Logic : Comp. Off & restart Every 360s

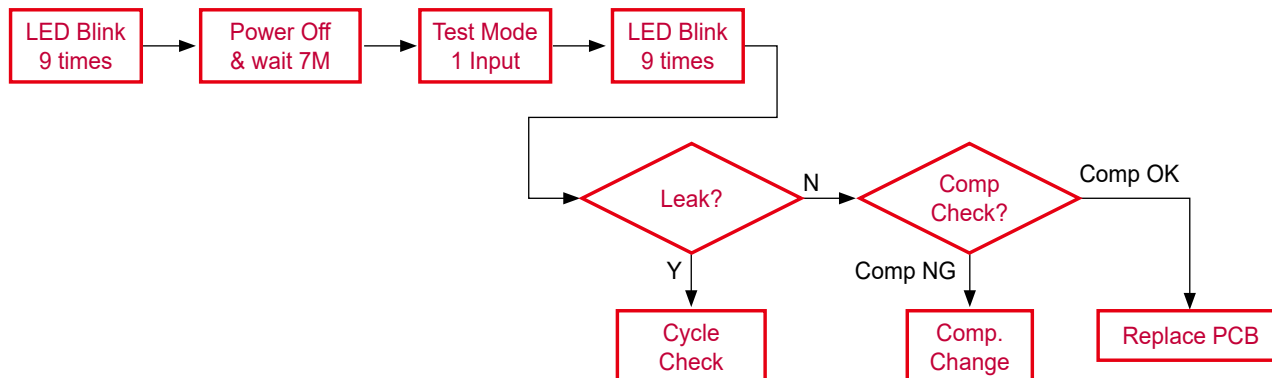



Compressor Troubleshooting

Check the Compressor & Harness

1. Check the Harness connection → Step 1. Power off.
2. Check the Compressor
Step 2. Check the Resistance(U-V,V-W,W-U → Every Resistance)
Step 3. Check the Harness(INF ohm).

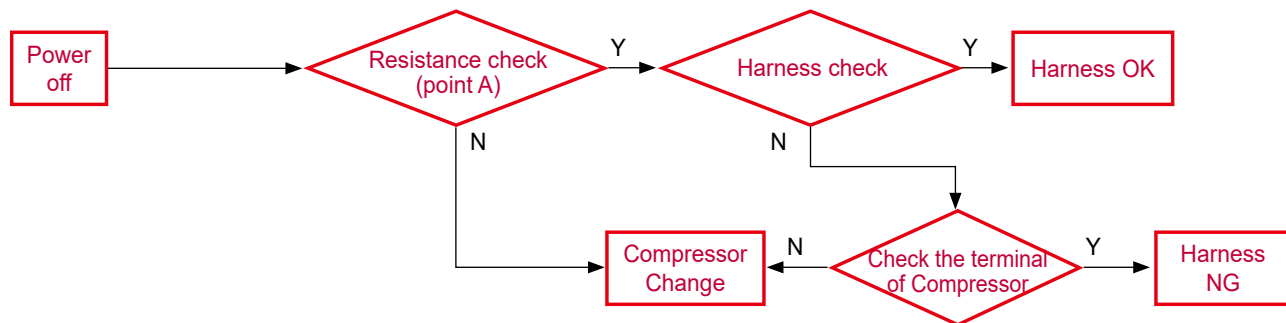



Compressor Troubleshooting

Check the Compressor & Harness

- Check the resistance (U/V/W)
- Check the broken-down insulation : Check the resistance between Comp. terminal and earth

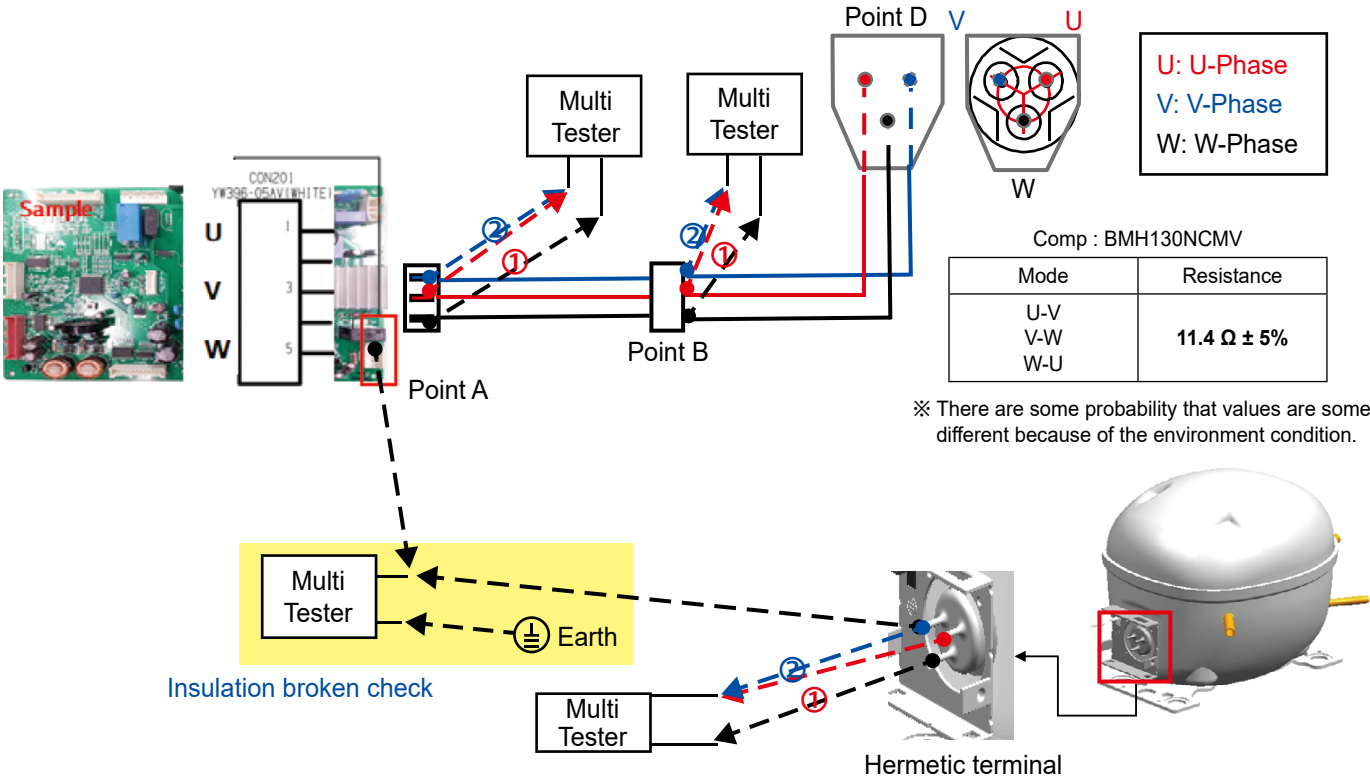



Compressor Troubleshooting

Check D

D1. Activate Protection logic

Cycle check with protection logic

- We have to check Condenser fan and Freezer fan before performing Check D
- Locked Piston, Current trip can be activated by other problems then the driver or compressor.

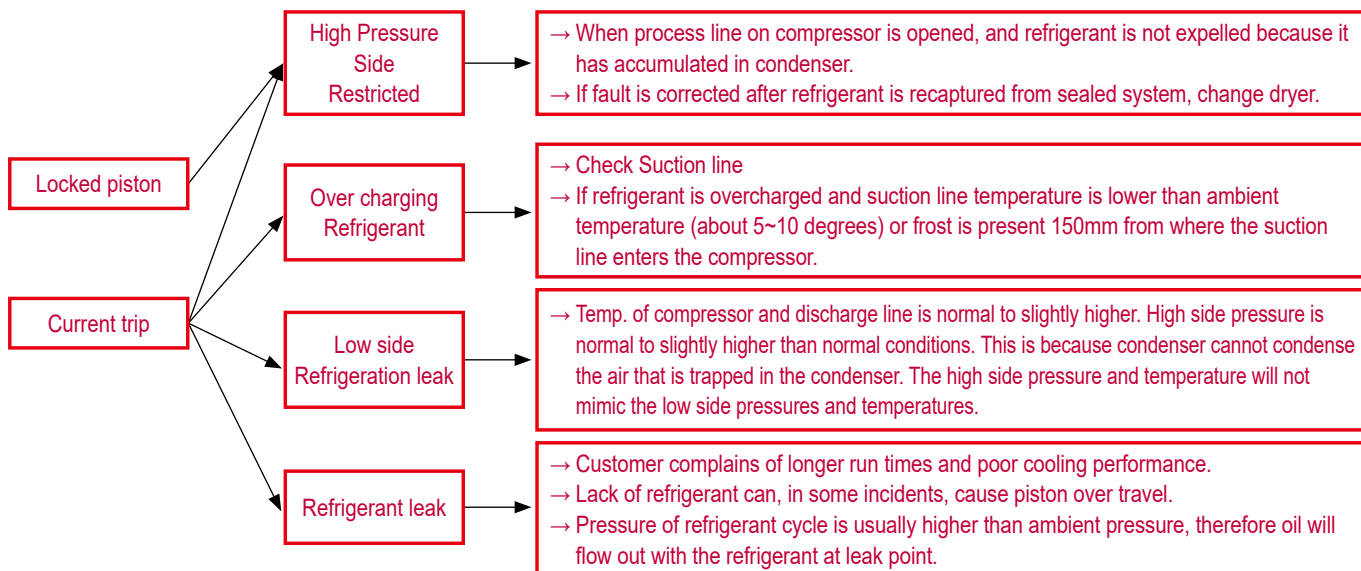

D2. sealed system diagnosis

- Check as follows;

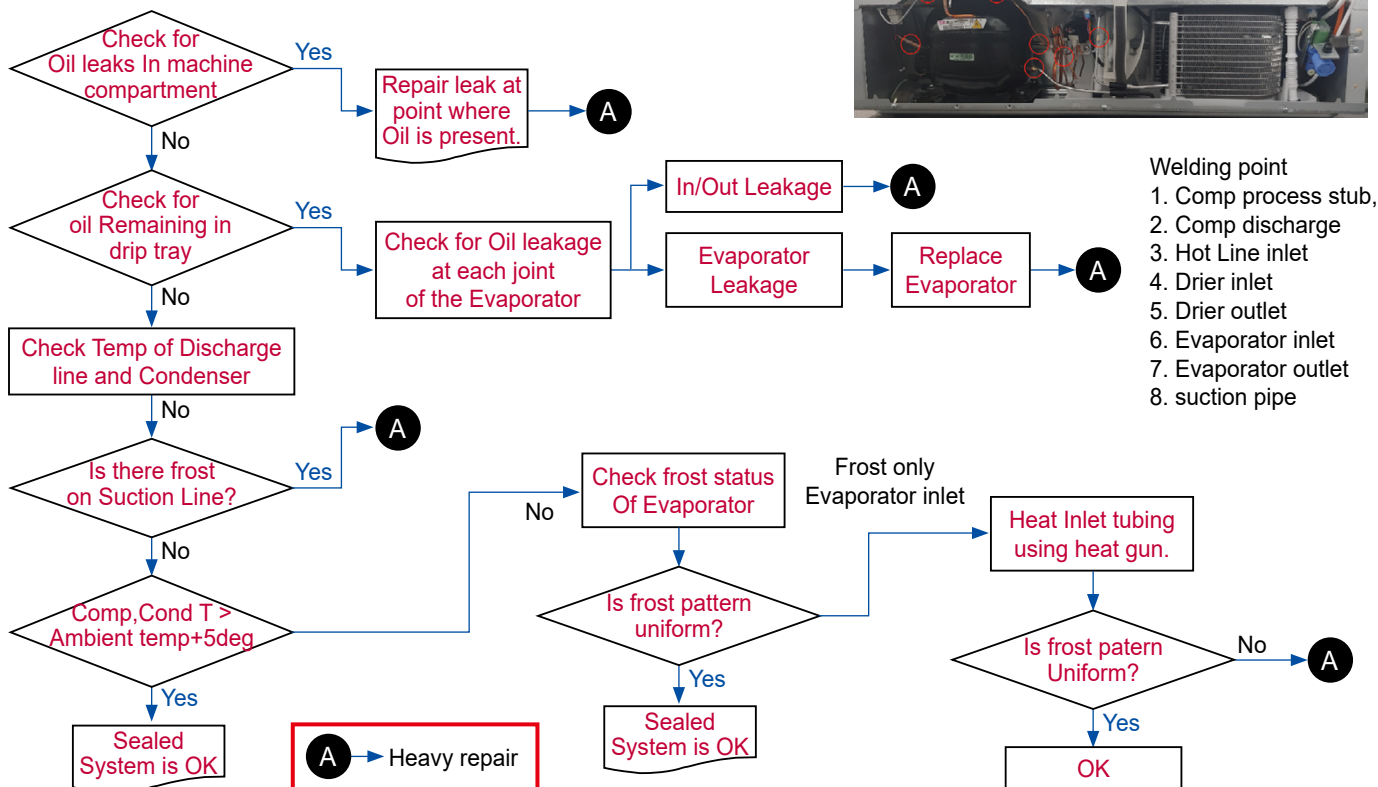



Compressor Troubleshooting

Service Diagnosis Chart

COMPLAINT	POINTS TO BE CHECKED	REMEDY
No Cooling.	<ul style="list-style-type: none"> Is the power cord unplugged from the outlet? Check if the power switch is set to OFF. Check if the fuse of the power switch is shorted. Measure the voltage of the power outlet. 	<ul style="list-style-type: none"> Plug into the outlet. Set the switch to ON. Replace the fuse. If the voltage is low, correct the wiring.
Cools poorly.	<ul style="list-style-type: none"> Check if the unit is placed too close to the wall. Check if the unit is placed too close to the stove, gas cooker, or in direct sunlight. Is the ambient temperature too high or the room door closed? Check if food put in the refrigerator is hot. Did you open the door of the unit too often or check if the door is sealed properly? Check if the Control is set to Warm position. 	<ul style="list-style-type: none"> Place the unit about 4 inches (10 cm) from the wall. Place the unit away from these heat sources. Lower the ambient temperature. Put in foods after they have cooled down. Don't open the door too often and close it firmly. Set the control to Recommended position.
Food in the Refrigerator is frozen.	<ul style="list-style-type: none"> Is food placed in the cooling air outlet? Check if the control is set to colder position. Is the ambient temperature below 41°F(5°C)? 	<ul style="list-style-type: none"> Place foods in the high-temperature section. (front part) Set the control to Recommended position. Set the control to Warm position.
Condensation or ice forms inside the unit.	<ul style="list-style-type: none"> Is liquid food sealed? Check if food put in the refrigerator is hot. Did you open the door of the unit too often or check if the door is sealed properly? 	<ul style="list-style-type: none"> Seal liquid foods with wrap. Put in foods after they have cooled down. Don't open the door too often and close it firmly.
Condensation forms in the Exterior Case.	<ul style="list-style-type: none"> Check if the ambient temperature and humidity of the surrounding air are high. Is there a gap in the door gasket? 	<ul style="list-style-type: none"> Wipe moisture with a dry cloth. It will disappear in low temperature and humidity. Fill up the gap.
There is abnormal noise.	<ul style="list-style-type: none"> Is the unit positioned in a firm and even place? Are any unnecessary objects placed in the back side of the unit? Check if the Drip Tray is not firmly fixed. Check if the cover of the compressor enclosure in the lower front side is taken out. 	<ul style="list-style-type: none"> Adjust the Leveling Screw, and position the refrigerator in a firm place. Remove the objects. Fix the Drip Tray firmly in the original position. Place the cover in its original position.
Door does not close well.	<ul style="list-style-type: none"> Check if the door gasket is dirty with an item like juice. Is the refrigerator level? Is there too much food in the refrigerator? 	<ul style="list-style-type: none"> Clean the door gasket. Position in a firm place and level the Leveling Screw. Make sure food stored in shelves does not prevent the door from closing.
Ice and foods smell unpleasant.	<ul style="list-style-type: none"> Check if the inside of the unit is dirty. Are foods with a strong odor unwrapped? The unit smells of plastic. 	<ul style="list-style-type: none"> Clean the inside of the unit. Wrap foods that have a strong odor. New products smell of plastic, but this will go away after 1-2 weeks.

Other possible problems:

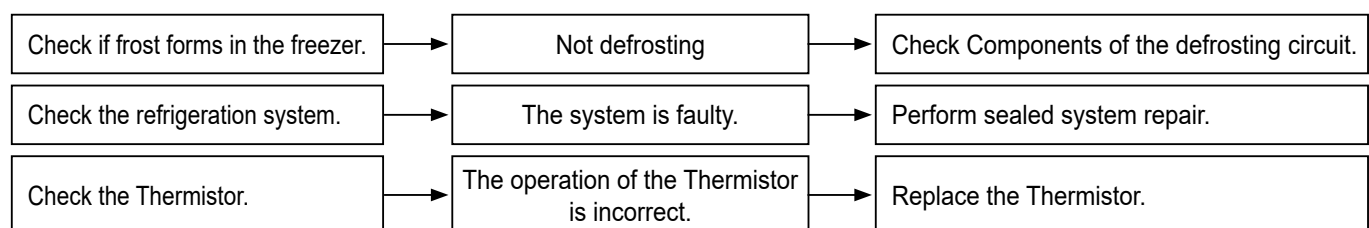



Compressor Troubleshooting

Refrigeration Cycle

• Troubleshooting Chart

CAUSE		STATE OF THE UNIT	STATE OF THE EVAPORATOR	TEMPERATURE OF THE COMPRESSOR	REMARKS
LEAKAGE	PARTIAL LEAKAGE	Freezer compartment and Refrigerator don't cool normally.	Low flowing sound of Refrigerant is heard and frost forms in inlet only.	A little higher than ambient temperature.	<ul style="list-style-type: none"> Refrigerant level is low due to a leak. Normal cooling is possible by restoring the normal amount of refrigerant and repairing the leak.
	COMPLETE LEAKAGE	Freezer compartment and Refrigerator don't cool normally.	Flowing sound of refrigerant is not heard and frost isn't formed.	Equal to ambient temperature.	<ul style="list-style-type: none"> No discharging of Refrigerant. Normal cooling is possible by restoring the normal amount of refrigerant and repairing the leak.
CLOGGED BY DUST	PARTIAL CLOG	Freezer compartment and Refrigerator don't cool normally.	Flowing sound of refrigerant is heard and frost forms in inlet only.	A little higher than ambient temperature.	<ul style="list-style-type: none"> Normal discharging of the refrigerant. The capillary tube is faulty.
	WHOLE CLOG	Freezer compartment and Refrigerator don't cool.	Flowing sound of refrigerant is not heard and frost isn't formed.	Equal to ambient temperature.	<ul style="list-style-type: none"> Normal discharging of the Refrigerant.
MOISTURE CLOG		Cooling operation stops periodically.	Flowing sound of refrigerant is not heard and frost melts.	Lower than ambient temperature.	<ul style="list-style-type: none"> Cooling operation restarts when heating the inlet of the capillary tube.
DEFECTIVE COMPRESSION	COMPRESSION	Freezer and Refrigerator don't cool.	Low flowing sound of refrigerant is heard and frost forms in inlet only.	A little higher than ambient temperature.	<ul style="list-style-type: none"> Low pressure at high side of compressor due to low refrigerant level.
	NO COMPRESSION	No compressing operation.	Flowing sound of refrigerant is not heard and there is no frost.	Equal to ambient temperature.	<ul style="list-style-type: none"> No pressure in the high pressure part of the compressor.

1. Cleaning

There is no need for routine condenser cleaning in normal Home operating environments. If the environment is particularly greasy or dusty, or there is significant pet traffic in the home, the condenser should be cleaned every 2 to 3 months to ensure maximum efficiency.

If you need to clean the condenser:

- Remove the mechanical cover.
- Use a vacuum cleaner with a soft brush to clean the grille, the open areas behind the grille and the front surface area of the condenser.
- Replace the mechanical cover.



Compressor Troubleshooting

2. Sealed System Diagnosis

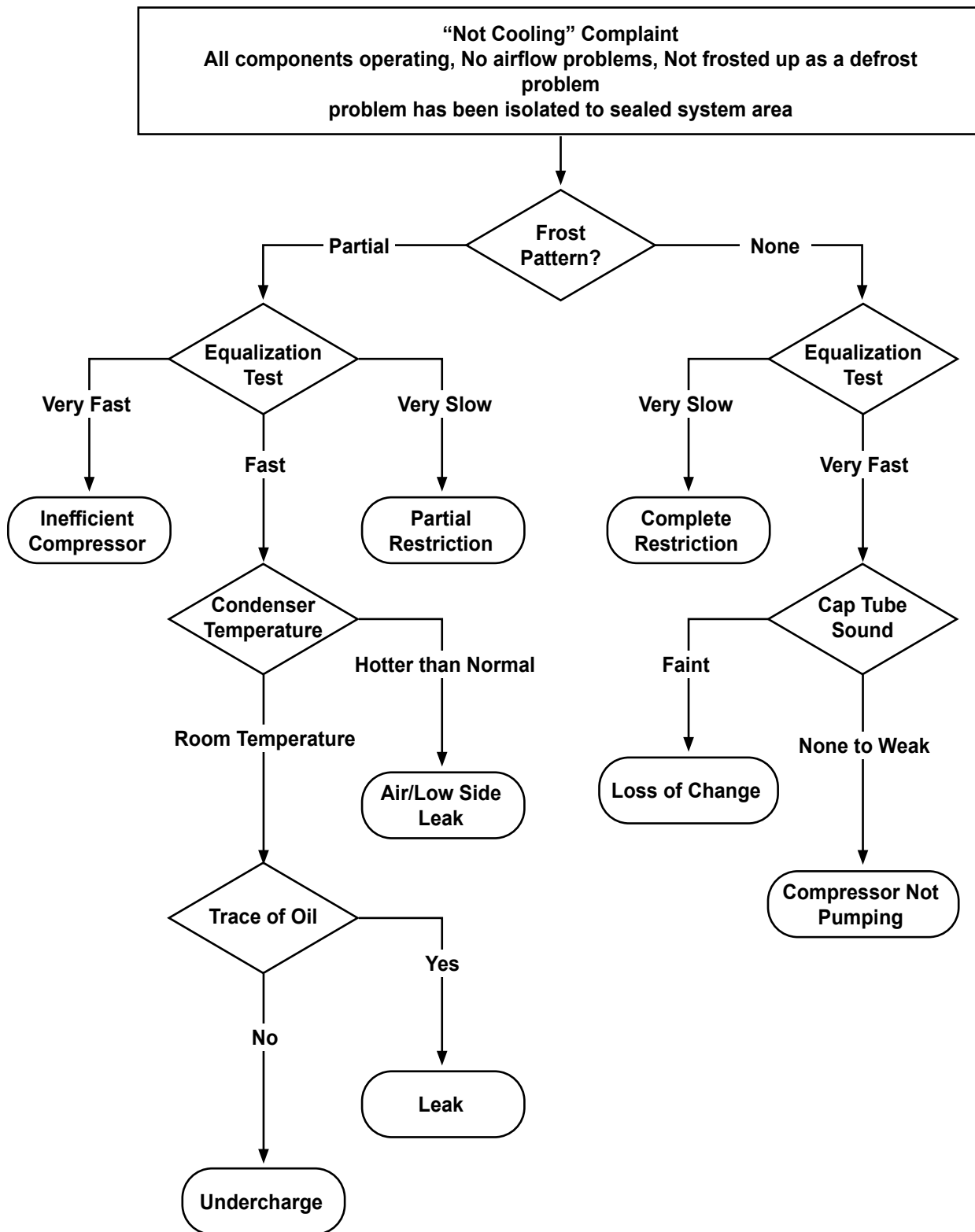

(The equalization test is trying to restart a compressor using a start kit after it has been operating.)



Icemaker Operating Method and Trouble Shooting

Icemaker's Basic Operating Method

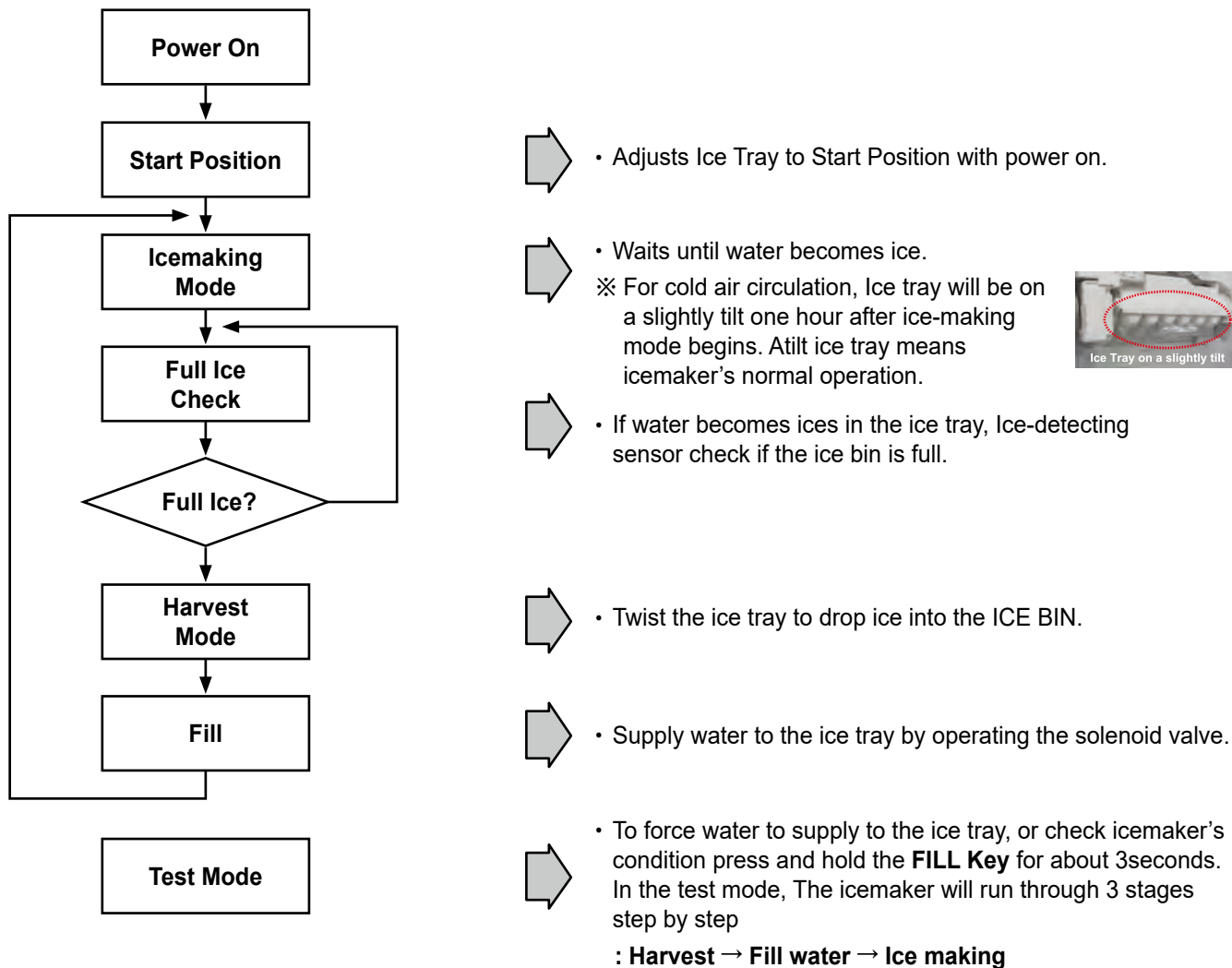

Ice Tray on a slightly tilt

To reset the icemaker's operation, set the power switch OFF position and back it to ON position.

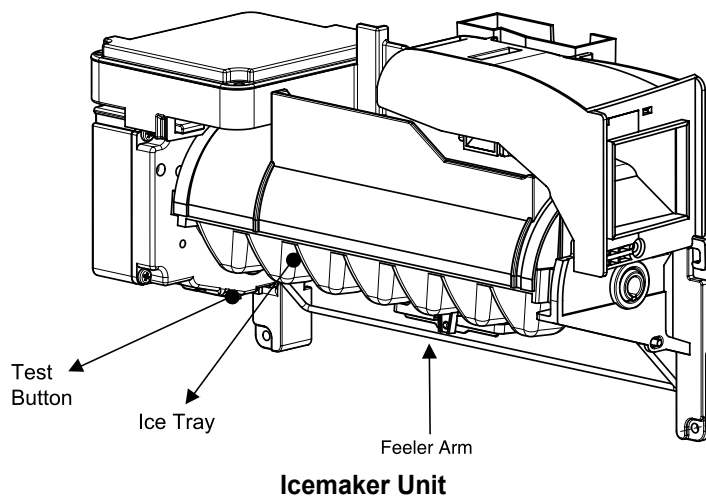



Icemaker Operating Method and Trouble Shooting

Icemaker Functions

1. Icemaking mode

1. Icemaking Mode begins right after the ice tray fills with water.
 2. Icemaker waits until water becomes ice in the ice tray.
- ※ Ice-detecting sensor checks if the ice bin is full every 2min.

2. Harvest mode

At least in 110min, since icemaker begun icemaking mode, Icemaker starts to twist the ice tray to drop ices into the Ice bin. (After installation, at least 1day is needed to make ices)

- ※ If the icemaker never drop ices to the ice bin though water becomes ices in the ice tray, check the real temperature of compartment. (not temperature on display) Icemaker needs below 0°F to drop ices to ice bin.

3. Fill/Park Position

Once the normal harvest mode has been completed, the water solenoid will be activated.

Trouble Shooting Ice & Water System Issues

1. Icemaker not making ice or not making enough ice (Environmental Diagnosis)

- Icemaker can't make ices itself. Basically, water, temperature and time are needed.
- Water : If no Water, then no Ice.
 - Temperature : The compartment, where the icemaker is located, has to be at least 1°F so that icemaker dumps ices to the bin.
 - Time : At least 80 minutes must be passed to make one series of ices after water comes into icemaker.
- ※ **Test Mode should not be carried out before checking below.**

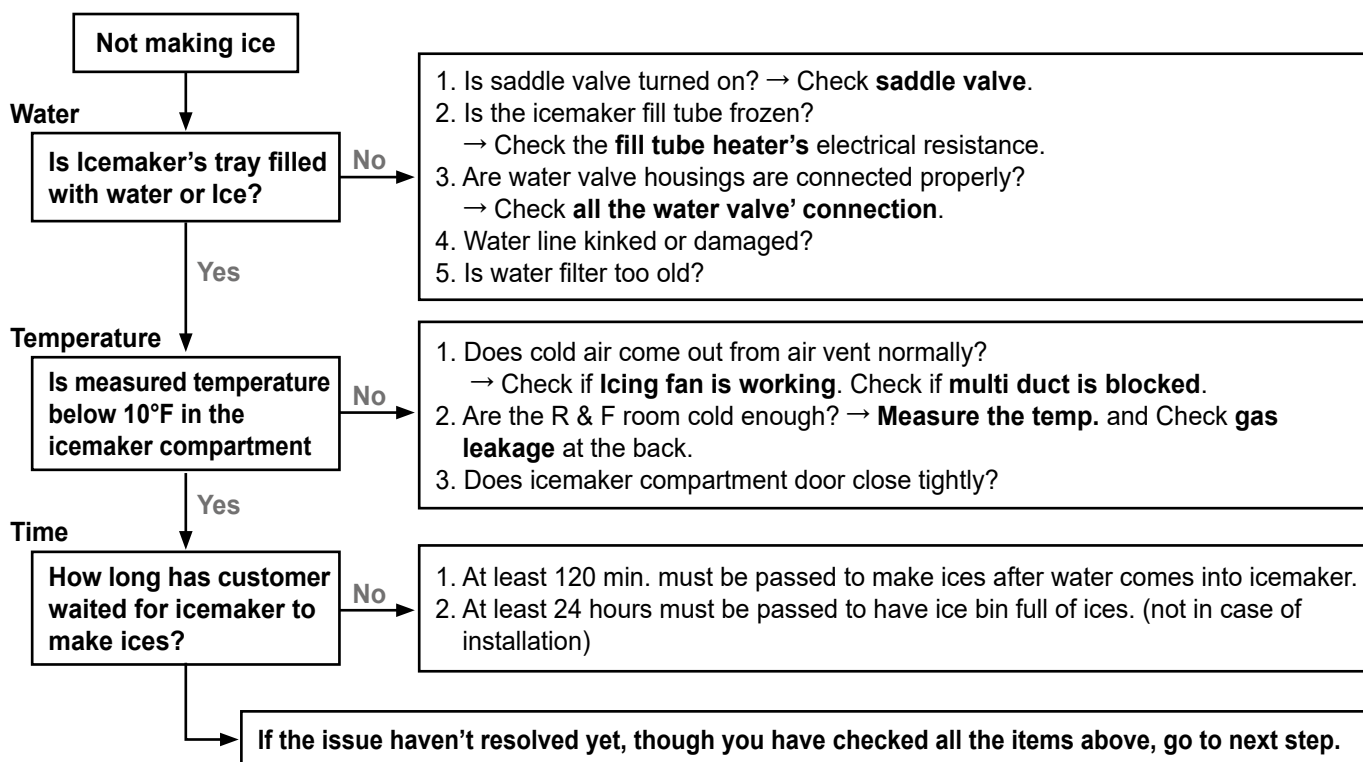



Icemaker Operating Method and Trouble Shooting

2. Icemaker not making ice or not making enough ice (Icemaker Unit & Ice-detecting sensor Diagnosis)

► Icemaker Unit and Ice-detecting sensor Diagnosis

The icemaker unit and Ice-detecting sensor is programmed to be diagnosed.

Follow the procedure step by step to check to see if icemaker and Ice-detecting sensor is working normally.

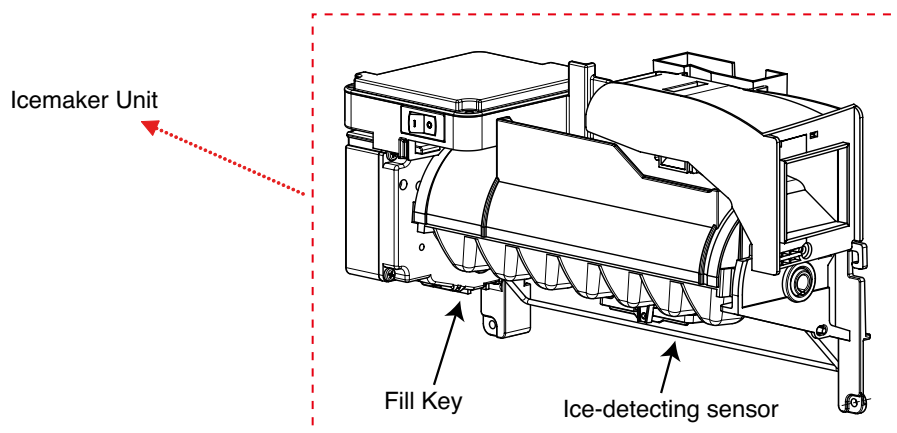

1st STEP (Icemaker Unit Diagnosis)

Press the fill key for about 3sec. If the icemaker runs 2 stages of harvest and filling water step by step, It means icemaker's mechanism is normal.

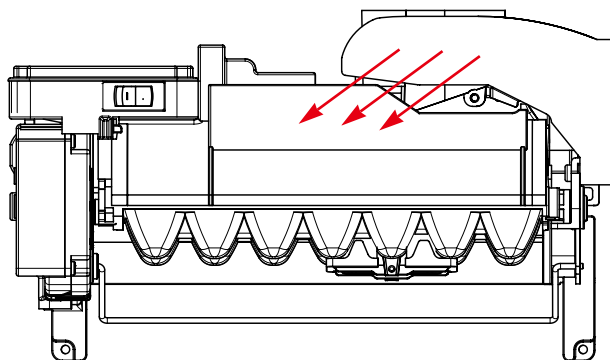

▲ CAUTION

Be sure that the ice tray is not filled with water before pressing fill key.



Icemaker Operating Method and Trouble Shooting

3. Icemaker not making ice or not making enough ice (Other suspected Items)

Strongly suspect items below If the issue remains yet, though all the diagnosis for icemaker has been carried out.

- Cap duct bad sealing
- Defective thermal sensor in the icemaker compartment
- Not cold icemaker compartment area (sealed system)

4. Not Dispensing Ice

► Clogged Ice In the Ice Bin (suspected items)

- Customer haven't used ice dispenser over a week.
 - **Resolution** : the ices gets stuck if customer doesn't use ice dispenser.
In this case, empty the ice bin and wait until the new ice s are stacked in the ice bin.
- Temperature of icemaker compartment is not cold enough.
 - **Resolution** : Check ice fan, sealed system, cap duct, vent and other items related to temperature.
- Cap duct doesn't seal the air properly.
 - **Resolution** : Possibly, warm air could get into the compartment and make ices get stuck. Replace the cap duct with new one.
- In-door geared motor doesn't work
 - **Resolution** : Change the in-door geared motor and test it.
- The water comes out of fill cup and the water get into the ice bin.
 - **Resolution** : The water pressure from shutoff valve is too high.
Recommend to use regulator to the customer and close the shutoff valve slightly.

► Clogged Ices In the Chute (suspected items)

- Cap duct doesn't seal the air properly.
 - **Resolution** : Possibly, warm air could get into the compartment and make ices get stuck. Replace the cap duct with new one.



Ice Maker(Freezer Room) Operating Method and Trouble Shoot

Ice Making Principles

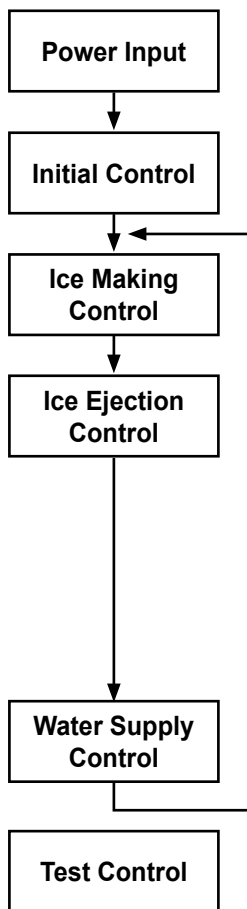

- Level Ice Maker Sphere Mould for "Initial Control" after power is input.
- Wait until the water in the sphere mould is frozen after ice maker starts operation.
- Check ice bucket is full of ice by rotating ice ejection motor in normal and reverse direction and eject ice into the ice bucket if ice bucket is not full.
- Conduct "Ice Making Control" after supplying water into the ice maker sphere mould by operating water valve.
- This is for refrigerator assembly line and service. When "ice making test switch" is pressed, it operates in the following steps: initial → ice ejection → water supply control steps.

Ice Tray position for each control step

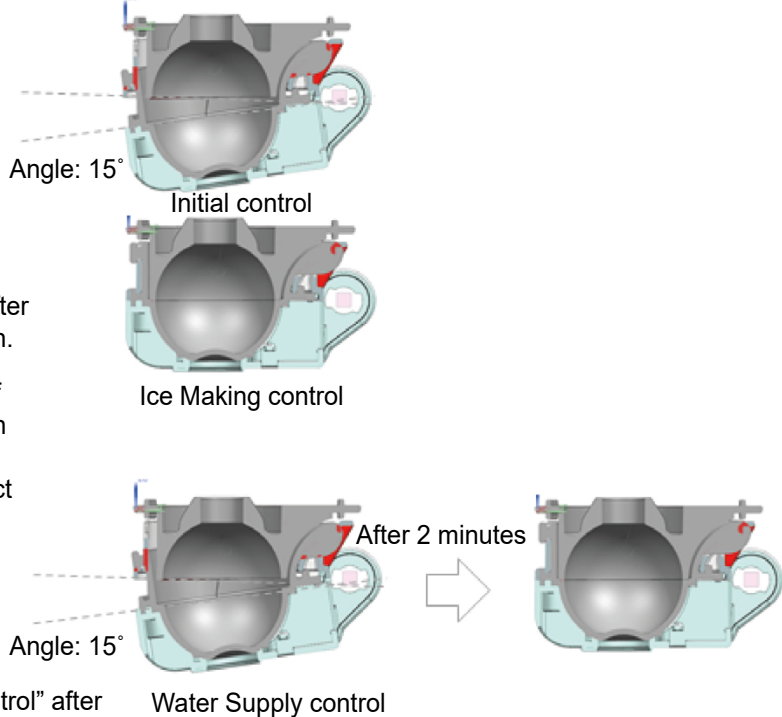

How to reset the icemaker

Press and hold the Test Button for over 3 seconds, then the icemaker diagnoses itself by carrying out the each control step by step.

- ※ Before you carry out the test mode,
 - Check the error code on display and follow 13-3
 - Check if the power switch is ON

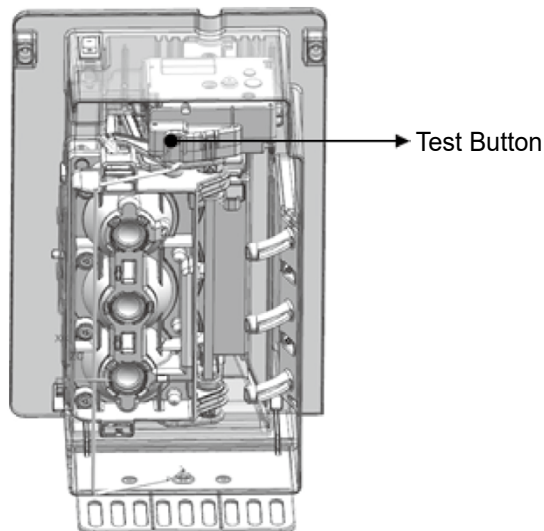
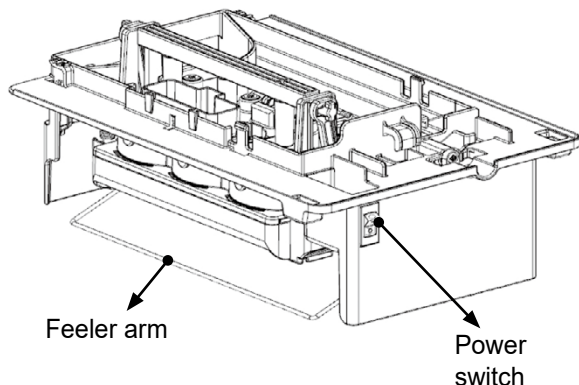





Ice Maker(Freezer Room) Operating Method and Trouble Shoot

Icemaker Issue Verification

1. Electrical part failure verification ("Freezer Temp. + Ice Plus" button for 3s continuously)

Symptom	Possible Cause	Issue on Icemaker	Customer's claim by the failure	Trouble shoot
Error code "IU EN" 	Harvest Heating Failure (Upper heater)	Icemaker stops making Ice	No Ice	Check upper heater Resistance
	Slow-melting Heating Failure (Lower heater)	Ice is more cloudy and Ice producing cycle is shorter than before	More cloudy ice than before Shape like lump on ice	Check Lower heater Resistance
	Ice tray out of position	Mechanical parts are interrupted and icemaker could not find position signal	No Ice	Carry out test mode with test switch
※ If no issue with trouble shoot, check the Main PCB and harness from main PCB to Icemaker.				
Error code "gF E" 	No water to Icemaker	No water supply to icemaker	No Ice	Check Tab water Valve Check water valve resistance
	No flow meter signal	Lack of water supply to icemaker	Half size (small size) of Ice	Check flow meter resistance
	Low water pressure to Icemaker - Low pressure from tap water - Old filter - No flushing since installation	Lack of water supply to icemaker		Call Plumber
				Replace new water filter
				Flushing the water

2. Mechanical part failure verification (Test switch on icemaker)

Symptom	Possible Cause	Issue on Icemaker	Customer's claim by the failure	Trouble shoot
No water to icemaker after movement	No water to Icemaker	No water supply to icemaker	No Ice	Check Tab water valve Check water valve resistance
Icemaker tray stays opening over 1min. *E IU error code	No Tray position signal	Could not proceed to water supplying and freezing mode		Change Icemaker
Never stop movement				



Ice Maker(Freezer Room) Operating Method and Trouble Shoot

Icemaker Issue Verification

New Mode for “Not enough Craft Ice” or “It takes too long to have Craft Ice” Issue

Please recommend the customer to set up and use “6 Ice” option.

If the customer claims for “Not enough ice” or “It takes too long to have Craft Ice” although the Craft icemaker works normally.

- “3 Ice”: 1 batch of ice will be harvested once (3 Ice) from Craft icemaker within about every 24 hours.
- “6 Ice”: 1 batches of ice will be harvested twice (6 Ice) from Craft icemaker within about every 24 hours.
(“3 Ice” is for clearer ice and “6 Ice” is for more ice.)

How to switch the mode

※ Factory Default Setting : 3ICE

1) Press any button on display to deactivate the power saving mode.

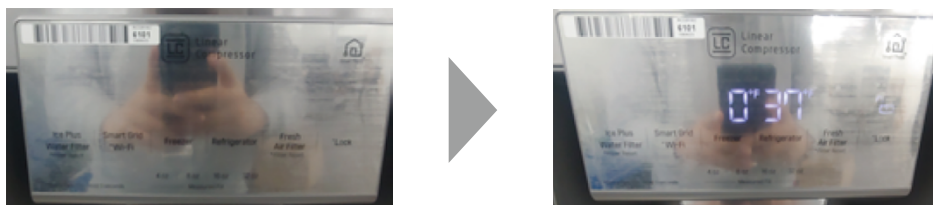

2) Press and hold the Freezer button for more than 3 seconds until the control panel beeps and the current setting appears.



3) Press the Freezer button to toggle between 3 ICE and 6 ICE modes.



4) If no button is pressed for over 5 seconds, the mode, which was shown on display at last, will be saved and the mode will work maximum 30 hours after the setting.



Exploded view & Replacement Parts list

CASE PARTS

CAUTION: Use the part number to order part, not the position number.

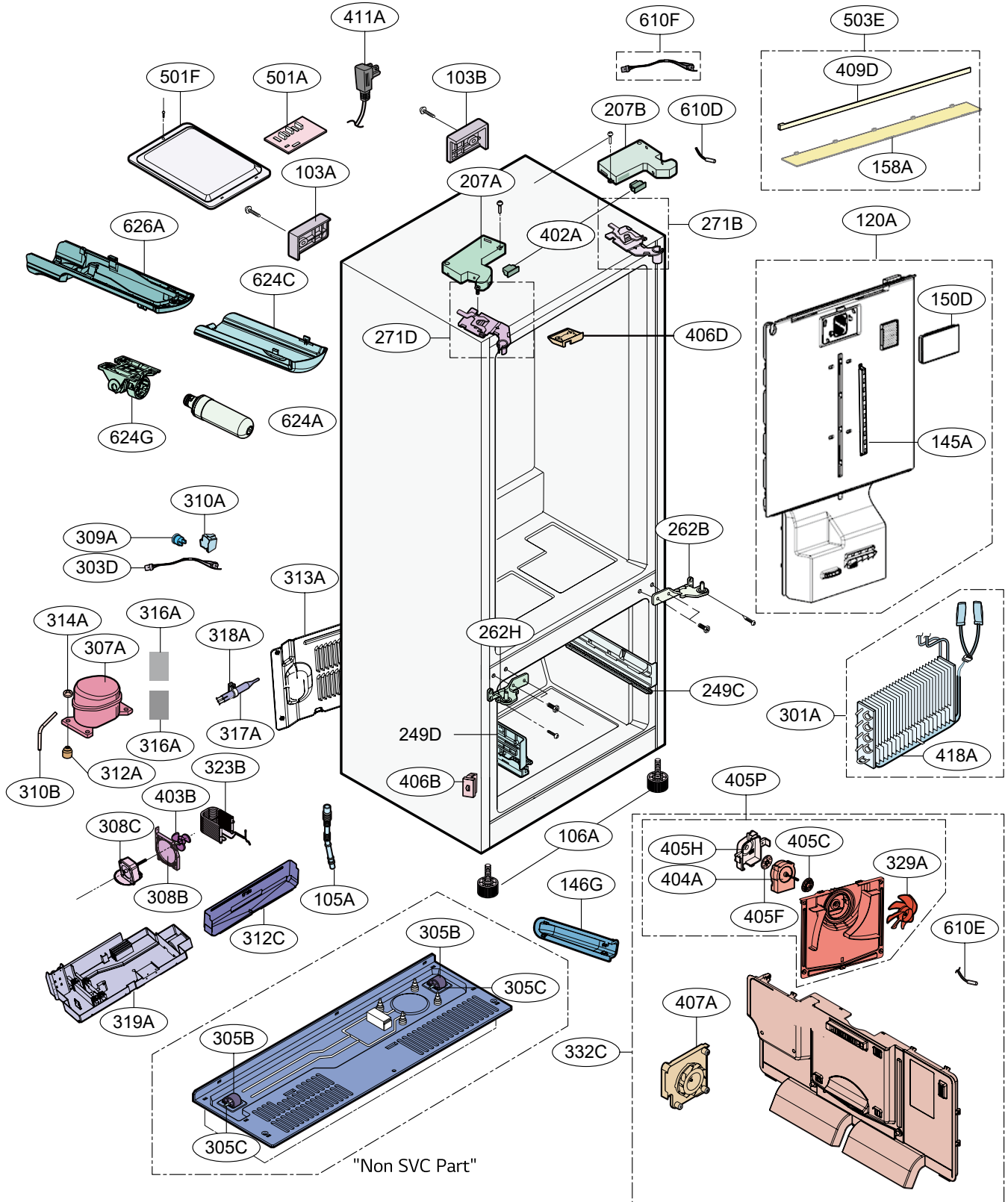



Exploded view & Replacement Parts list

FREEZER PARTS

CAUTION: Use the part number to order part, not the position number.

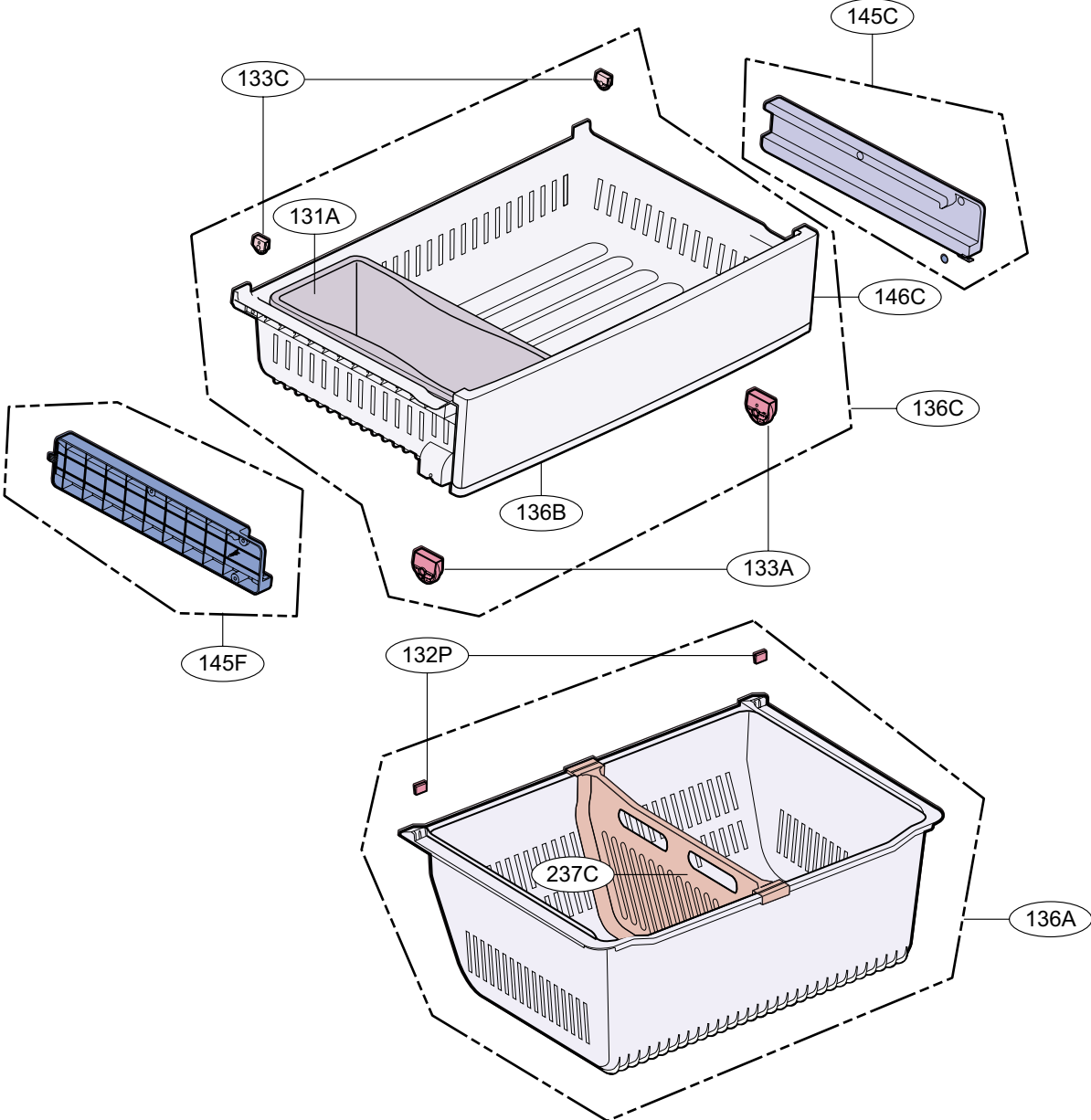



Exploded view & Replacement Parts list

REFRIGERATOR PARTS

CAUTION: Use the part number to order part, not the position number.

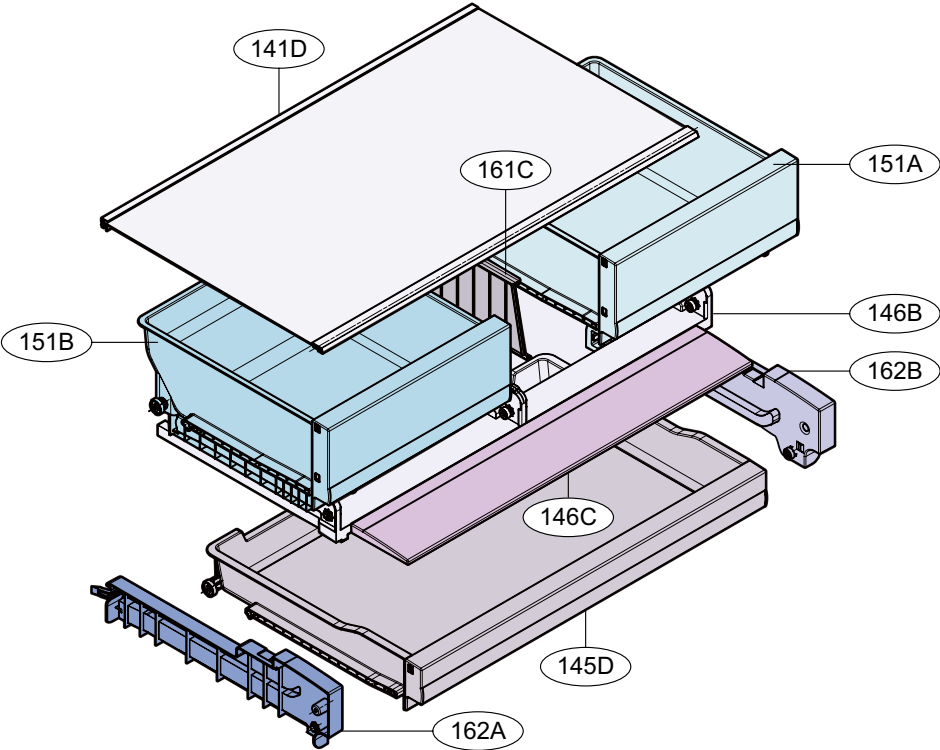
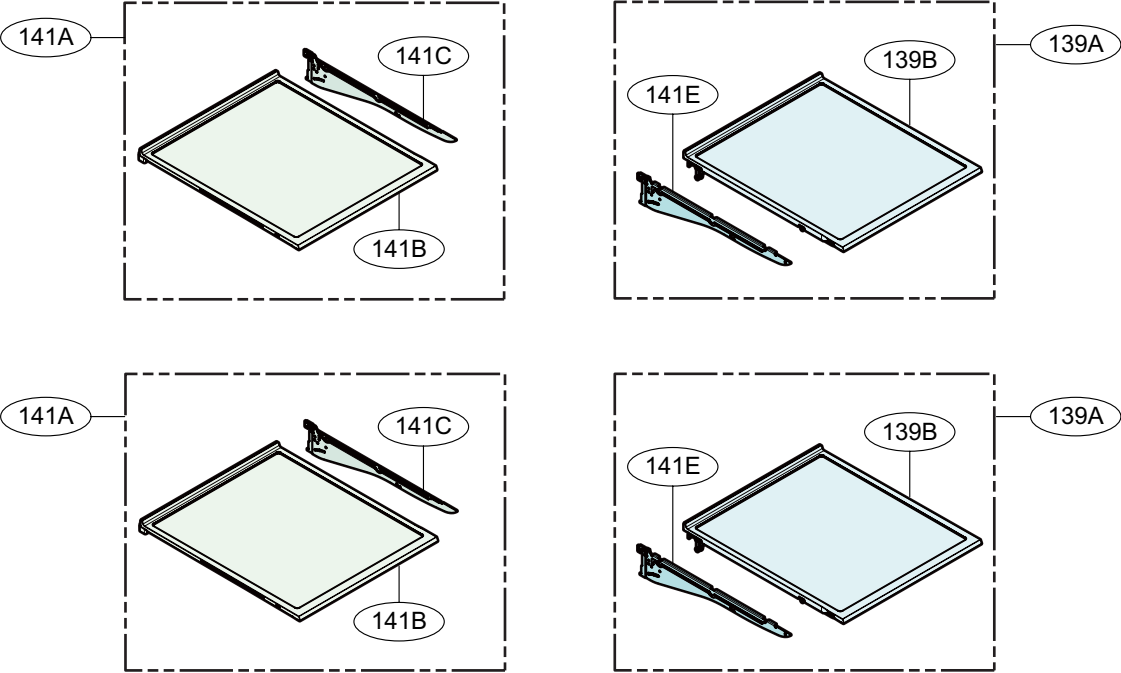



Exploded view & Replacement Parts list

DOOR PARTS

CAUTION: Use the part number to order part, not the position number.

"231B" has to provide "212G" together.

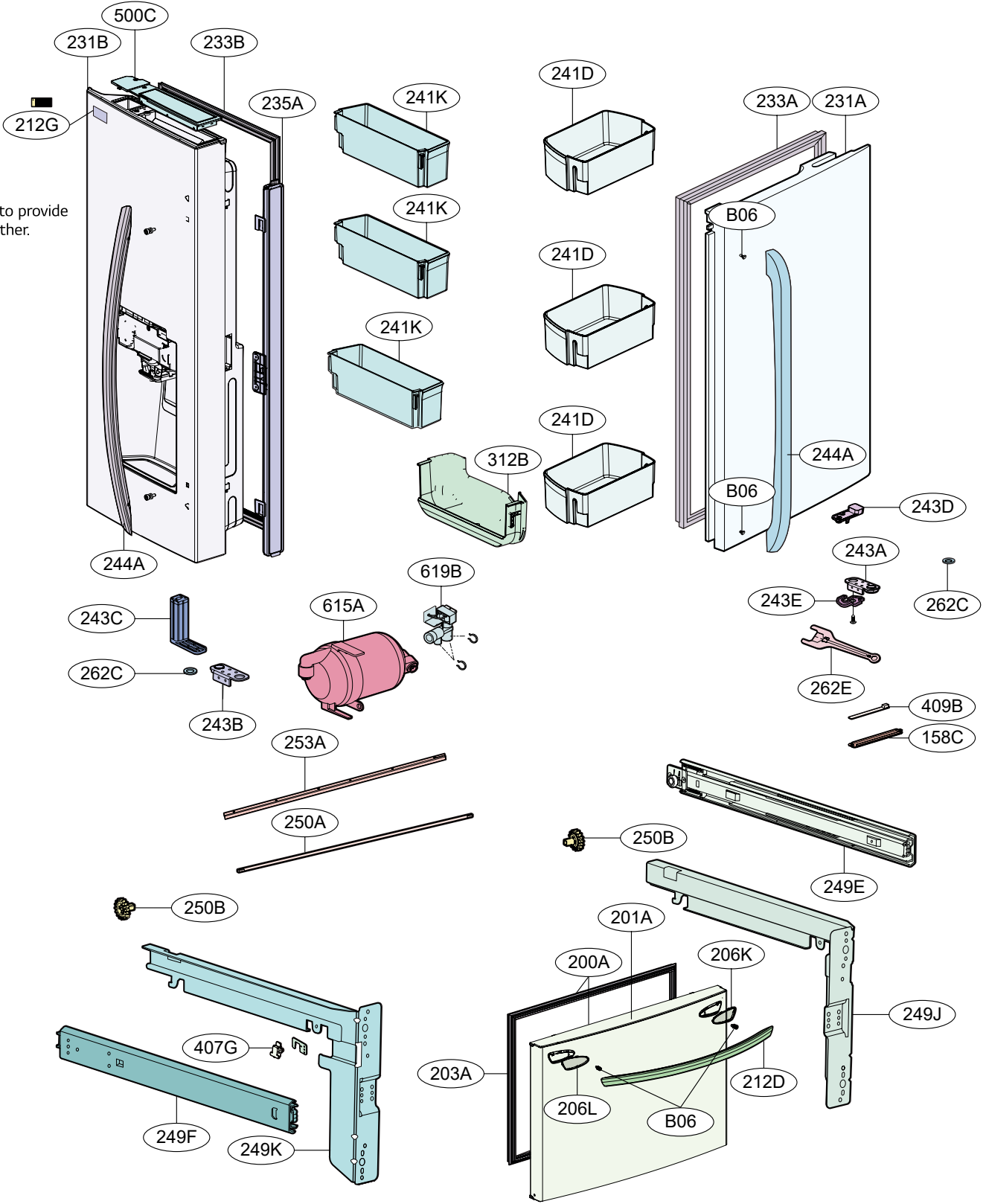



Exploded view & Replacement Parts list

DISPENSER PARTS

CAUTION: Use the part number to order part, not the position number.
Related on location number of (*) mark, It's same with produced by China Model. So that parts are supplied by China, Please refer to the list.

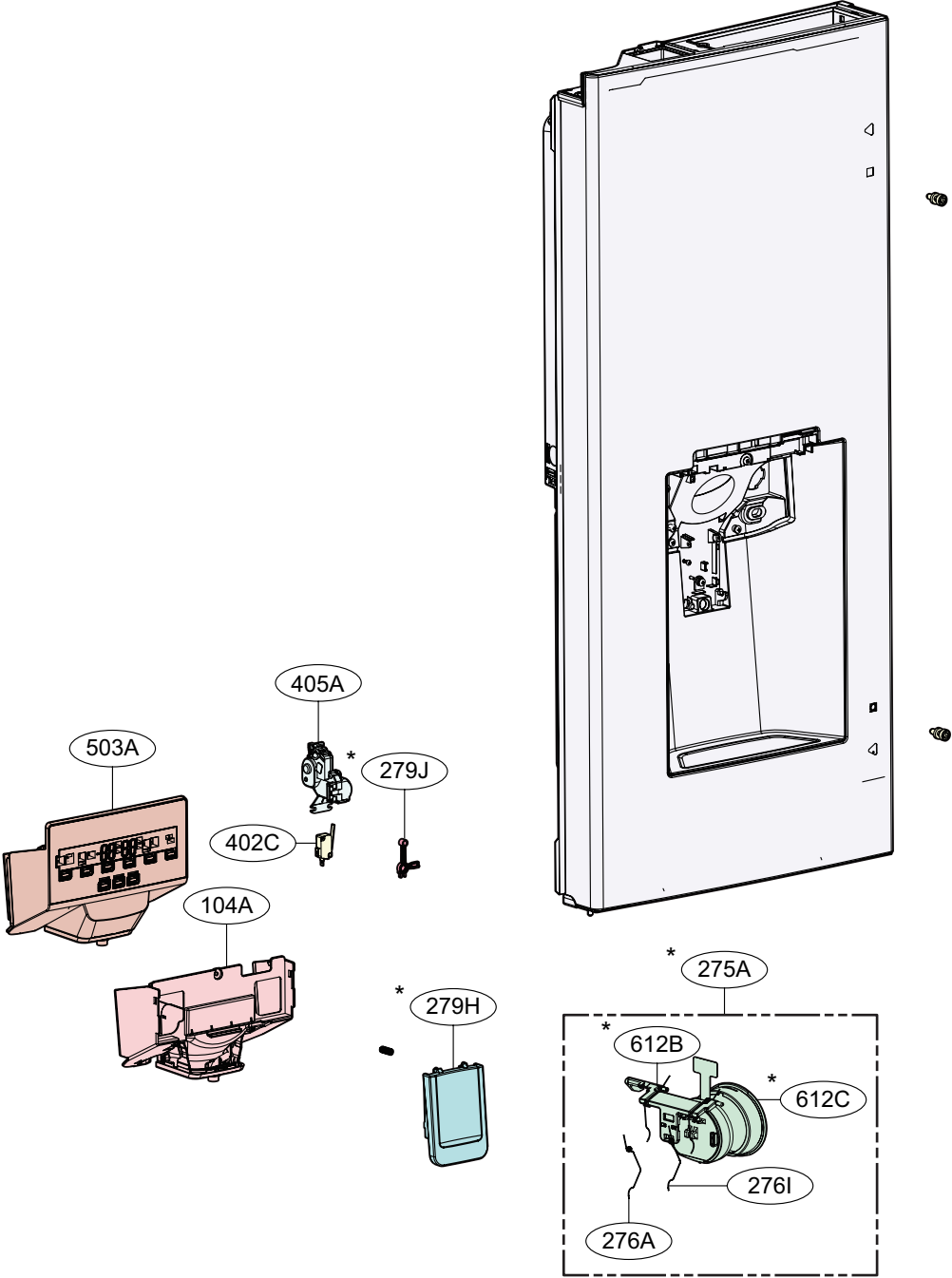



Exploded view & Replacement Parts list

VALVE & WATER TUBE PARTS

CAUTION: Use the part number to order part, not the position number.

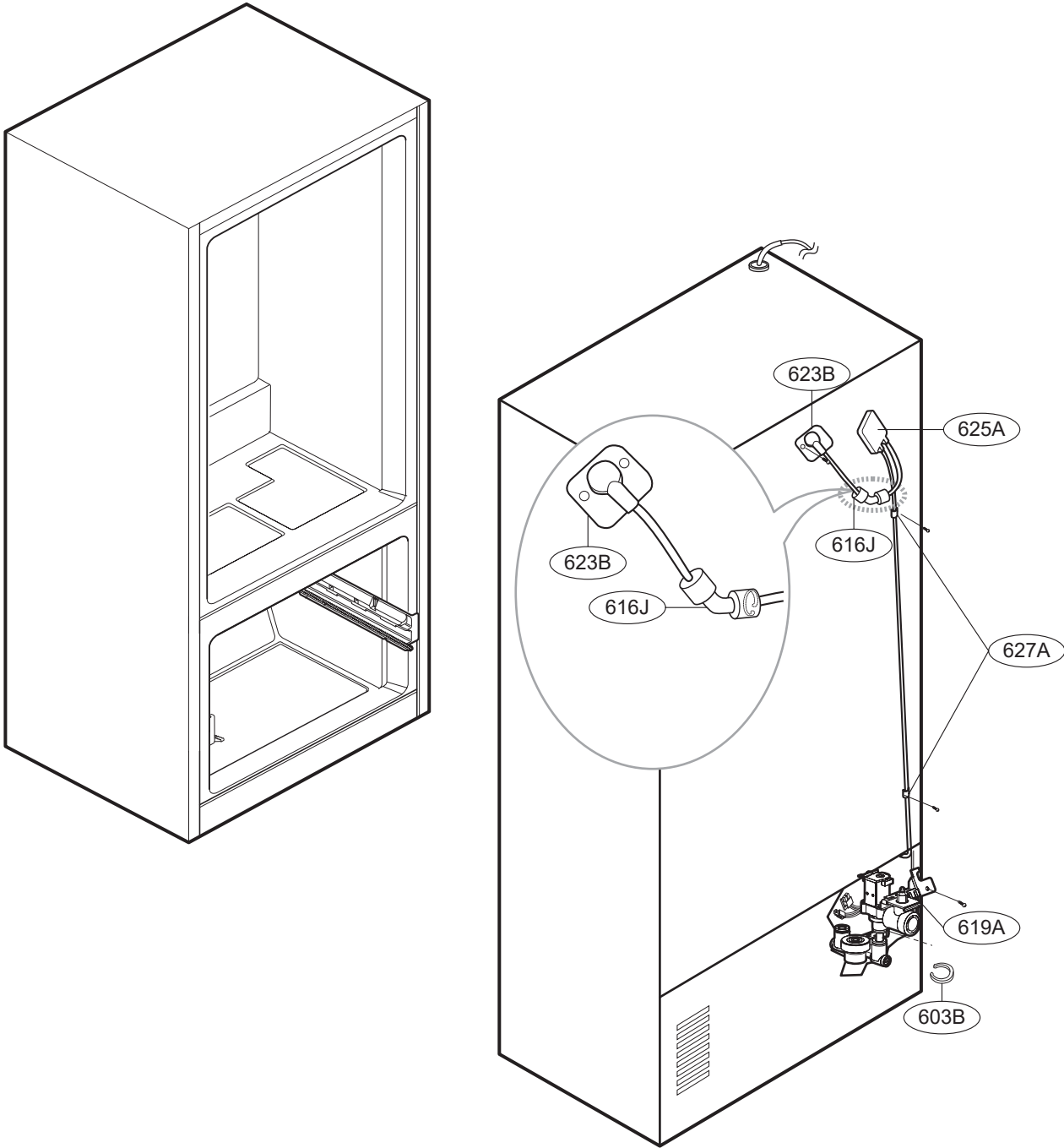



Exploded view & Replacement Parts list

ICE MAKER & ICE BIN PARTS

CAUTION: Use the part number to order part, not the position number.

Related on location number of (*) mark, It's same with produced by China Model. So that parts are supplied by China, Please refer to the list.

