



РУССКИЙ ЯЗЫК

ENGLISH

ITALIANO

ESPAÑOL

FRANÇAIS

DEUTSCH

EMHNIKA

ČEŠTINA

NEDERLANDS

POLSKI

LIMBA ROMÂNĂ

INSTALLATION MANUAL

# AIR-TO-WATER HEAT PUMP

Please read this installation manual completely before installing the product. Installation work must be performed in accordance with the national wiring standards by authorized personnel only. Please retain this installation manual for future reference after reading it thoroughly.

## Hydro Kit

Original instruction (R410A/R32)



MFL67086712  
Rev.12\_103125



[www.lg.com](http://www.lg.com)

Copyright © 2018 - 2025 LG Electronics Inc. All Rights Reserved.

# TABLE OF CONTENTS

## 3 Safety instructions

---

## 9 Installation Parts

---

## 10 General Information

---

10 Model Information

12 General Information

## 13 Installation

---

13 Transporting the Unit

14 Selection of the best location

14 Installation Space

17 Foundation for Installation

18 Water Piping and Water Circuit Connection

21 Installation Scenes

28 Refrigerant Piping

31 How to connect wirings

32 Wiring Connection

34 Connecting Cables

## 37 Accessories Installation

---

37 Location of Accessories and External Parts Connection

39 Main Pump Connection

39 Water tank temperature sensor Connection

40 Thermostat

44 Remote Temperature Sensor

45 3Way Valve

47 2Way Valve

48 Dry Contact

50 External Controller

51 External pump

52 Wi-fi Modem

53 Smart Grid

## 54 System Set-Up

---

54 DIP Switch Setting

57 Group Control Setting

61 Installer Setting

## 74 Test Run

---

74 Caution before Operation Test

74 Operation Test of Water Pipe





75 Troubleshooting

77 Airborne Noise Emission

77 Model Designation

# Safety instructions

The following symbols are displayed on indoor and outdoor units.

	Read the precautions in this manual carefully before operating the unit.		This appliance is filled with flammable refrigerant. (for R32)
	This symbol indicates that the Operation Manual should be read carefully.		This symbol indicates that a service personnel should be handling this equipment with reference to the Installation Manual.

The following safety guidelines are intended to prevent unforeseen risks or damage from unsafe or incorrect operation of the appliance. The guidelines are separated into 'WARNING' and 'CAUTION' as described below.

 This symbol is displayed to indicate matters and operations that can cause risk. Read the part with this symbol carefully and follow the instructions in order to avoid risk.

## **WARNING**

This indicates that the failure to follow the instructions can cause serious injury or death.

## **CAUTION**

This indicates that the failure to follow the instructions can cause the minor injury or damage to the product.

## **WARNING**

### Installation

- Compliance with national gas regulations shall be observed.
- Do not use a defective or underrated circuit breaker. Use this appliance on a dedicated circuit.
  - There is risk of fire or electric shock.
- For electrical work, contact the dealer, seller, a qualified electrician, or an Authorized Service Center.
  - There is risk of fire or electric shock.
- Always ground the unit.
  - There is risk of fire or electric shock.

- Install the panel and the cover of control box securely.
  - There is risk of fire or electric shock.
- Always install a dedicated circuit and breaker.
  - Improper wiring or installation may cause fire or electric shock.
- Be cautious when unpacking and installing the product.
  - Sharp edges could cause injury. Be especially careful of the case edges and the fins on the condenser and evaporator.
- Use the correctly rated breaker or fuse.
  - There is risk of fire or electric.
- Do not modify or extend the power cable.
  - There is risk of fire or electric shock.
- Do not install, remove, or reinstall the unit by yourself (customer).
  - There is risk of fire, electric shock, explosion, or injury.
- For antifreeze, always contact the dealer or an authorized service center.
  - Almost the antifreeze is a toxic product.
- For installation, always contact the dealer or an Authorized Service Center.
  - There is risk of fire, electric shock, explosion, or injury.
- Do not install the unit on a defective installation stand.
  - It may cause injury, accident, or damage to the unit.
- Do not turn on the breaker or power under condition that front panel, cabinet, top cover, control box cover are removed or opened.
  - Otherwise, it may cause fire, electric shock, explosion or death.
- Be sure the installation area does not deteriorate with age.
  - If the base collapses, the unit could fall with it, causing property damage, unit failure, and personal injury.
- Do not install the unit outdoor.
  - It may cause damage to the unit.
- Use a vacuum pump or inert (nitrogen) gas when doing leakage test or purging air. Do not compress air or oxygen and do not use flammable gases.
  - There is the risk of death, injury, fire or explosion.
- The appliance shall be stored in a well-ventilated area where the room size corresponds to the room area as specified for operation. (for R32)
- Ducts connected to an appliance shall not contain an ignition source. (for R32)

- The appliance shall be stored in a room without continuously operating ignition sources (for example: open flames, an operating gas appliance or an operating electric heater.)
- Means for disconnection must be incorporated in the fixed wiring in accordance with the wiring rules.
- This equipment shall be provided with a supply conductor complying with the national regulation.
- Have all electric work done by a licensed electrician according to "Electric Facility Engineering Standard" and "Interior Wire Regulations" and the instructions given in this manual and always use a special circuit.
  - If the power source capacity is inadequate or electric work is performed improperly, electric shock or fire may result.
- Always install a dedicated circuit and breaker.
  - Improper wiring or installation may cause fire or electric shock.
- Keep any required ventilation openings clear of obstruction.
- Mechanical connections shall be accessible for maintenance purposes.
- To prevent the mixing of different types of refrigerants, be sure to check the type of refrigerant used in the outdoor unit.
- When mechanical connectors are reused indoors, sealing parts shall be renewed. (for R32)
- When flared joints are reused indoors, the flare part shall be re-fabricated. (for R32)

## **Operation**

- Do not let the air conditioner run for a long time when the humidity is very high and a door or a window is left open.
  - Moisture may condense and wet or damage furniture.
- Take care to ensure that power cable could not be pulled out or damaged during operation.
  - There is risk of fire or electric shock.
- Do not place anything on the power cable.
  - There is risk of fire or electric shock.
- Do not plug or unplug the power supply plug during operation.
  - There is risk of fire or electric shock.
- Do not touch (operate) the unit with wet hands.
  - There is risk of fire or electric shock.
- Do not place a heater or other appliances near the power cable.
  - There is risk of fire or electric shock.

- Do not allow water to run into electric parts.
  - There is risk of fire, failure of the unit, or electric shock.
- Do not store or use flammable gas or combustibles near the unit.
  - There is risk of fire or failure of unit.
- Do not use the product in a tightly closed space for a long time.
  - Oxygen deficiency could occur.
- When flammable gas leaks, turn off the gas and open a window for ventilation before turning the unit on.
  - There is risk of explosion or fire.
- If strange sounds, or smell or smoke comes from unit, turn the breaker off or disconnect the power supply cable.
  - There is risk of electric shock or fire.
- Stop operation and close the window in storm or hurricane. If possible, remove the unit from the window before the hurricane arrives.
  - There is risk of property damage, failure of unit, or electric shock.
- Do not open the front cover of the unit while operation. (Do not touch the electrostatic filter, if the unit is so equipped.)
  - There is risk of physical injury, electric shock, or unit failure.
- When the unit is soaked (flooded or submerged), contact an Authorized Service Center.
  - There is risk of fire or electric shock.
- Be cautious that water could not enter the product.
  - There is risk of fire, electric shock, or product damage.
- Ventilate the unit from time to time when operating it together with a stove, etc.
  - There is risk of fire or electric shock.
- Turn the main power off when cleaning or maintaining the unit.
  - There is risk of electric shock.
- Take care to ensure that nobody could step on or fall onto the unit.
  - This could result in personal injury and unit damage.
- For installation, always contact the dealer or an Authorized Service Center.
  - There is risk of fire, electric shock, explosion, or injury.
- If the unit is not used for long time, we strongly recommend not to switch off the power supply to the unit.
  - There is risk of water freezing.
- Periodic ( more than once/year ) cleaning of the dust or salt particles stuck on the heat exchanger by using water.

- Do not use means to accelerate the defrosting process or to clean, other than those recommended by the manufacturer.
- Do not pierce or burn refrigerant cycle part.
- Be aware that refrigerants may not contain an odour.

---

---

**⚠ CAUTION**

---

---

## **Installation**

- Always check for gas (refrigerant) leakage after installation or repair of unit.
  - Low refrigerant levels may cause failure of unit.
- Keep level even when installing the unit.
  - To avoid vibration or water leakage.
- Use two or more people to lift and transport the unit.
  - Avoid personal injury.
- Any person who is involved with working on or breaking into a refrigerant circuit should hold a current valid certificate from an industry accredited assessment authority, which authorises their competence to handle refrigerants safely in accordance with an industry recognised assessment specification. (for R32)
- The appliance shall be stored so as to prevent mechanical damage from occurring.
- If anyone other than a licensed Professional installs, repairs, or alters LG Electronics Air Conditioning Products, the warranty is voided.
  - All costs associated with repair are then the full responsibility of the owner.
- Do not install the product where it will be exposed to sea wind (salt spray) directly.
  - It may cause corrosion on the product. Corrosion, particularly on the condenser and evaporator fins, could cause product malfunction or inefficient operation.
- Refrigerant tubing shall be protected or enclosed to avoid damage.
- Flexible refrigerant connectors (such as connecting lines between the indoor and outdoor unit) that may be displaced during normal operations shall be protected against mechanical damage.
- The installation of pipe-work shall be kept to a minimum.
- Pipe-work shall be protected from physical damage.

- A brazed, welded, or mechanical connection shall be made before opening the valves to permit refrigerant to flow between the refrigerating system parts.
- Dismantling the unit, treatment of the refrigerant oil and eventual parts should be done in accordance with local and national standards.
- Do not install the unit in potentially explosive atmospheres.





## **Operation**

- Do not lay on the cooled floor for long time when the unit is in cooling operation.
  - This could harm to your health.
- Do not use the unit for special purposes, such as preserving foods, works of art, etc.
  - There is risk of damage or loss of property.
- Use a soft cloth to clean. Do not use harsh detergents, solvents, etc.
  - There is risk of fire, electric shock, or damage to the plastic parts of the unit.
- Do not step on or put anything on the unit.
  - There is risk of personal injury and failure of unit.
- Use a firm stool or ladder when cleaning or maintaining the unit.
  - Be careful and avoid personal injury.
- Servicing shall only be performed as recommended by the equipment manufacturer. Maintenance and repair requiring the assistance of other skilled personnel shall be carried out under the supervision of the person competent in the use of flammable refrigerants. (for R32)
- Do not unplug the power supply plug of Hydro Kit when stopping Hydro Kit operation. Always turn Hydro Kit off, using the wired remote controller.
  - A plate heat exchanger burst may happen because of disconnection of communication between Hydro Kit and the outdoor unit.

# Installation Parts

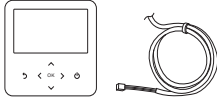
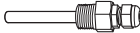
Thank you for choosing LG Electronics **Hydro Kit**.

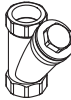
Before starting installation, please make it sure that all parts are found inside the unit box.

Item	Image	Quantity
Remote Controller / Cable		1
Sensor Holder		1
Water Tank Temperature Sensor		1
Strainer		1
Owner's & Installation manual		1
CN_EXT Cable		1

# General Information

With advanced inverter technology, **Hydro Kit** is suitable for applications like under floor heating, and hot water generation. By Interfacing to various accessories user can customize the range of the application.

## Model Information

### Model name and related information

#### • For Medium Temperature

Type		<b>Hydro Kit</b>		
HP		10	4	
Power Supply		Ø, V, Hz		
		1, 220-240, 50		
Capacity	Cooling	kW	28	12.3
		kcal/h	24 100	10 580
		Btu/h	95 900	42 000
	Heating	kW	31.5	13.8
		kcal/h	27 100	11 870
		Btu/h	107 500	47 000

\*1 : Tested under Eurovent Heating condition  
(water temperature 30 °C → 35 °C at outdoor ambient temperature 7 °C / 6 °C)

\*2 : Tested under Eurovent Cooling condition  
(water temperature 23 °C → 18 °C at outdoor ambient temperature 35 °C / 24 °C)

- Max Allowable pressure  
High side : 4.2 MPa / Low Side : 2.4 MPa
- Max Allowable water temperature  
High side : 50 °C / Low side : 10 °C
- Max Allowable water pressure 0.98 MPa (0.3~10 kgf/cm<sup>2</sup>)

## • For High Temperature

Type			Hydro Kit	
HP			8	4
Power Supply		Ø, V, Hz	1, 220-240, 50	
Capacity	Heating	kW	25.2	13.8
		kcal/h	21 700	11 870
		Btu/h	85 900	47 000
Refrigerant	Type		R134a	
	Quantity	kg(lbs)	3(6.6)	2.3(5.04)

\*1 : Tested under Eurovent Heating condition

(Water temperature 55 °C → 65 °C at outdoor ambient temperature 7 °C / 6 °C)

- Max Allowable pressure

High side : 4.2 MPa / Low Side : 2.4 MPa

- Max Allowable water temperature

High side : 80 °C / Low side : 10 °C

- Max Allowable water pressure 0.98 MPa (0.3~10 kgf/cm<sup>2</sup>)

## General Information

To extend the functionality of **Hydro Kit**, there are various external auxiliary apparatus called as "accessories".

They are classified by "accessories" and "3rd party accessories" according to the manufacturer. Accessories are presented LG Electronics, and 3rd party accessories are presented by related manufacturers.

### Accessories supported by LG Electronics

Item	Purpose	Model (Medium Temperature)	Model (High Temperature)
Remote Air Sensor	To control the unit by air temperature	PQRSTA0	PQRSTA0
Dry Contact	To receive on & off external signal	PDRYCB000 / PDRYCB100 / PDRYCB300	PDRYCB000 / PDRYCB100 / PDRYCB300
Solar Thermal Kit	To operate with sanitary water tank	PHLLA	

### Accessories supported by 3<sup>rd</sup> party Companies

Item	Purpose	Specification
Solar Thermal System	To generate auxiliary heating energy for water tank	
Thermostat	To control the unit by air temperature	Heating-Only type (230 V AC or 24 V AC) Cooling/Heating type (230 V AC or 24 V AC with Mode selection switch)
3way valve and actuator	To control water flow for hot water heating or floor heating	3 wire, SPDT (Single Pole Double Throw) type, 230 V AC
2way valve and actuator	To control water flow for Fan Coil Unit	2 wire, NO(Normal Open) or NC (Normal Closed) type, 230 V AC

# Installation

## Transporting the Unit

### • For High Temperature

- When carrying the suspended unit, pass the ropes between legs of base panel under the unit.
- Always lift the unit with ropes attached at 6 points so that impact is not applied to the unit.
- Attach the ropes to the unit at an angle (A) of 40° or less.
- Use only accessories and parts which are of the designated specification when installing.

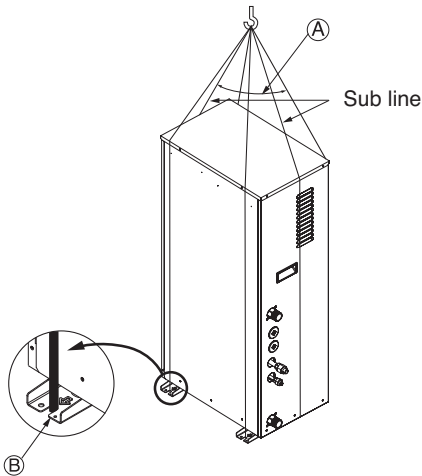

- (A) 40° or less
- (B) Line supporter

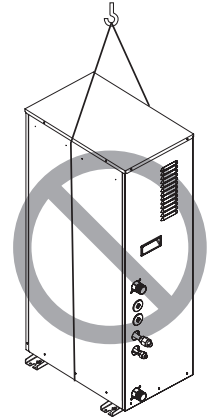

## **⚠ CAUTION**

**Be very careful while carrying the unit.**

- Do not have only one person carry the unit if it is more than 20 kg (44.1 lbs).
- PP bands are used to pack some products. Do not use them as a mean for transportation because they are dangerous.
- Tear plastic packaging bag and scrap it so that children cannot play with it. Otherwise plastic packaging bag may suffocate children to death.
- When carrying the unit, be sure to support it at 6-points. Carrying and lifting the unit with 4-point support may make it unstable, resulting in a fall.

## Selection of the best location

Select space for installing the unit, which will meet the following conditions:

The place where the unit shall be installed inside.

The place shall easily bear a load exceeding four times of the unit weight.

The place where the unit shall be leveled.

The place shall allow easy water drainage.

The place where the unit shall be connected to the outdoor unit.

The place where the unit is not affected by an electrical noise.

The place where there should not be any heat source or steam near the unit.

## Installation Space

• The following values are the least space for installation.

If any service area is needed for service according to field circumstance, obtain enough service space.

• The unit of values is mm(inch).

### <For Medium Temperature>

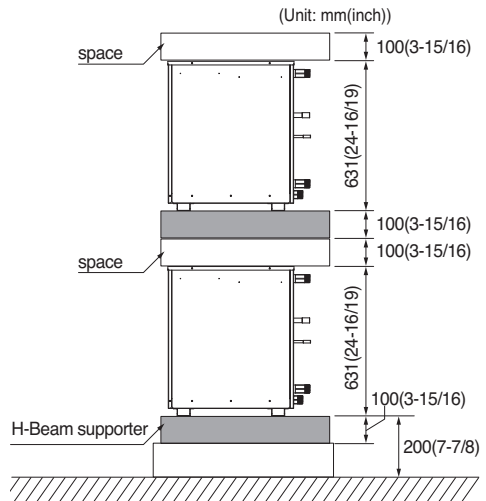
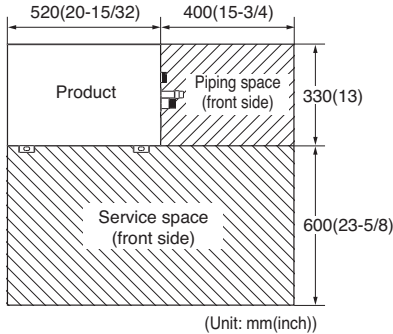

<For High Temperature>

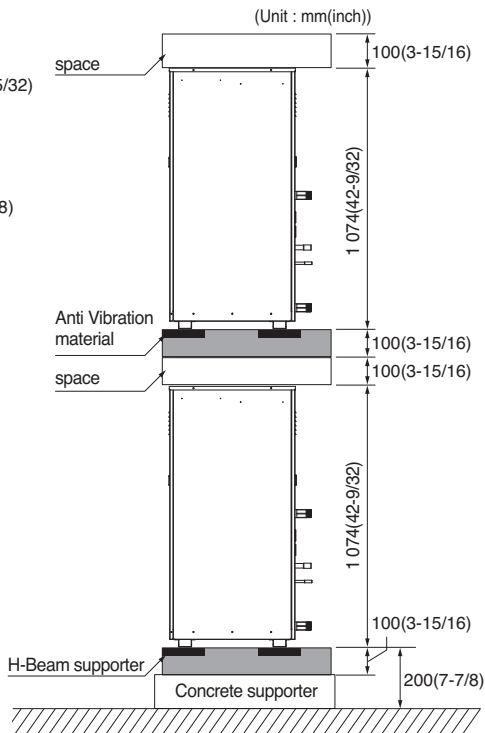
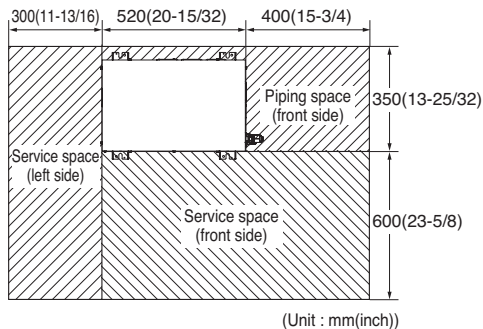

## Minimum floor area (for R32)

- The appliance shall be installed, operated and stored in a room with a floor area larger than the minimum area.
- Use the graph of table to determine the minimum area.

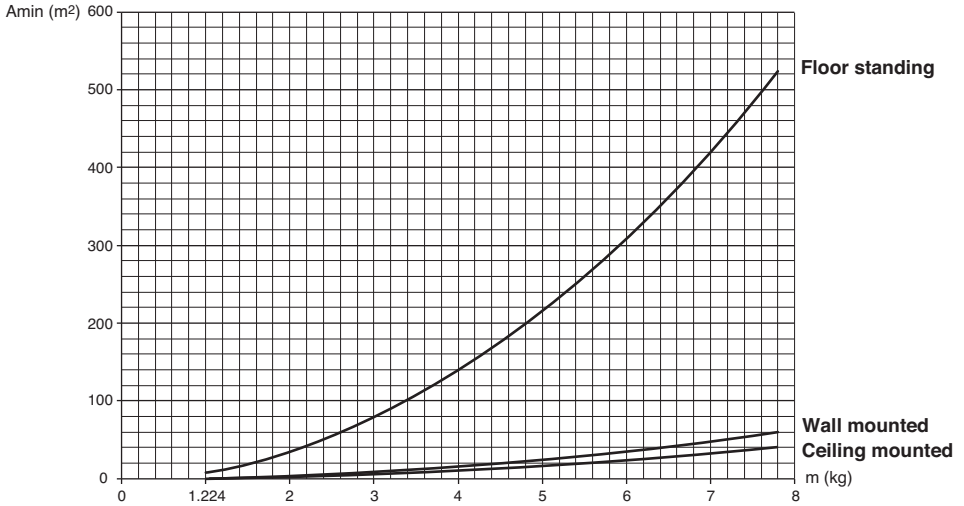

- m : Total refrigerant amount in the system.
- Total refrigerant amount : factory refrigerant charge + additional refrigerant amount.
- Amin : minimum area for installation.

Floor location		Floor location	
m (kg)	Amin (m²)	m (kg)	Amin (m²)
< 1.224	-	4.6	181.56
1.224	12.9	4.8	197.70
1.4	16.82	5	214.51
1.6	21.97	5.2	232.02
1.8	27.80	5.4	250.21
2	34.32	5.6	269.09
2.2	41.53	5.8	288.65
2.4	49.42	6	308.90
2.6	58.00	6.2	329.84
2.8	67.27	6.4	351.46
3	77.22	6.6	373.77
3.2	87.86	6.8	396.76
3.4	99.19	7	420.45
3.6	111.20	7.2	444.81
3.8	123.90	7.4	469.87
4	137.29	7.6	495.61
4.2	151.36	7.8	522.04
4.4	166.12	8	549.16

Wall mounted		Wall mounted	
m (kg)	Amin (m²)	m (kg)	Amin (m²)
< 1.224	-	4.6	20.17
1.224	1.43	4.8	21.97
1.4	1.87	5	23.83
1.6	2.44	5.2	25.78
1.8	3.09	5.4	27.80
2	3.81	5.6	29.90
2.2	4.61	5.8	32.07
2.4	5.49	6	34.32
2.6	6.44	6.2	36.65
2.8	7.47	6.4	39.05
3	8.58	6.6	41.53
3.2	9.76	6.8	44.08
3.4	11.02	7	46.72
3.6	12.36	7.2	49.42
3.8	13.77	7.4	52.21
4	15.25	7.6	55.07
4.2	16.82	7.8	58.00
4.4	18.46	8	61.00

Ceiling Mounted		Ceiling Mounted	
m (kg)	Amin (m²)	m (kg)	Amin (m²)
< 1.224	-	4.6	13.50
1.224	0.956	4.8	14.70
1.4	1.25	5	15.96
1.6	1.63	5.2	17.26
1.8	2.07	5.4	18.61
2	2.55	5.6	20.01
2.2	3.09	5.8	21.47
2.4	3.68	6	22.98
2.6	4.31	6.2	24.53
2.8	5.00	6.4	26.14
3	5.74	6.6	27.80
3.2	6.54	6.8	29.51
3.4	7.38	7	31.27
3.6	8.27	7.2	33.09
3.8	9.22	7.4	34.95
4	10.21	7.6	36.86
4.2	11.26	7.8	38.83
4.4	12.36	8	40.86

Ceiling Mounted		Ceiling Mounted	
m (kg)	Amin (m²)	m (kg)	Amin (m²)
< 1.224	-	4.6	13.50
1.224	0.956	4.8	14.70
1.4	1.25	5	15.96
1.6	1.63	5.2	17.26
1.8	2.07	5.4	18.61
2	2.55	5.6	20.01
2.2	3.09	5.8	21.47
2.4	3.68	6	22.98
2.6	4.31	6.2	24.53
2.8	5.00	6.4	26.14
3	5.74	6.6	27.80
3.2	6.54	6.8	29.51
3.4	7.38	7	31.27
3.6	8.27	7.2	33.09
3.8	9.22	7.4	34.95
4	10.21	7.6	36.86
4.2	11.26	7.8	38.83
4.4	12.36	8	40.86

Ceiling Mounted		Ceiling Mounted	
m (kg)	Amin (m²)	m (kg)	Amin (m²)
< 1.224	-	4.6	13.50
1.224	0.956	4.8	14.70
1.4	1.25	5	15.96
1.6	1.63	5.2	17.26
1.8	2.07	5.4	18.61
2	2.55	5.6	20.01
2.2	3.09	5.8	21.47
2.4	3.68	6	22.98
2.6	4.31	6.2	24.53
2.8	5.00	6.4	26.14
3	5.74	6.6	27.80
3.2	6.54	6.8	29.51
3.4	7.38	7	31.27
3.6	8.27	7.2	33.09
3.8	9.22	7.4	34.95
4	10.21	7.6	36.86
4.2	11.26	7.8	38.83
4.4	12.36	8	40.86

Ceiling Mounted		Ceiling Mounted	
m (kg)	Amin (m²)	m (kg)	Amin (m²)
< 1.224	-	4.6	13.50
1.224	0.956	4.8	14.70
1.4	1.25	5	15.96
1.6	1.63	5.2	17.26
1.8	2.07	5.4	18.61
2	2.55	5.6	20.01
2.2	3.09	5.8	21.47
2.4	3.68	6	22.98
2.6	4.31	6.2	24.53
2.8	5.00	6.4	26.14
3	5.74	6.6	27.80
3.2	6.54	6.8	29.51
3.4	7.38	7	31.27
3.6	8.27	7.2	33.09
3.8	9.22	7.4	34.95
4	10.21	7.6	36.86
4.2	11.26	7.8	38.83
4.4	12.36	8	40.86

## Foundation for Installation

- Fix the unit tightly with bolts as shown below so that the unit will not fall down due to earthquake.
- Noise and vibration may occur from the floor or wall since vibration is transferred through the installation part depending on installation status. Thus, use anti-vibration materials (cushion pad) fully (The base pad shall be more than 200 mm (7-7/8 inch)).

### <For Medium Temperature>

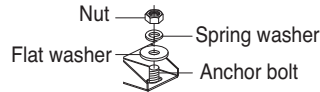
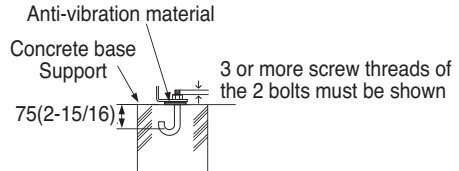
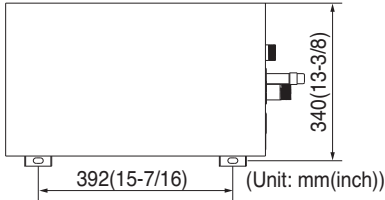

### <For High Temperature>

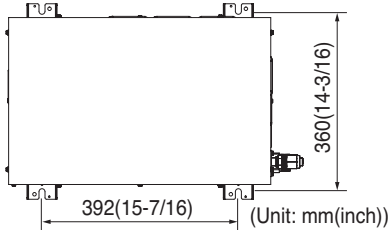

## ⚠ CAUTION

- When mechanical connectors are reused indoors, sealing parts shall be renewed. (for R32)
- When flared joints are reused indoors, the flare part shall be re-fabricated. (for R32)

## Drain pipe connection (For Medium Temperature)

- **Hydro Kit** does not use the drain pump.
- Do not install in upward direction.
- Install the drain pipe in downward direction (1/50-1/100).
- **Hydro Kit** drain connection pipe is PT 1.

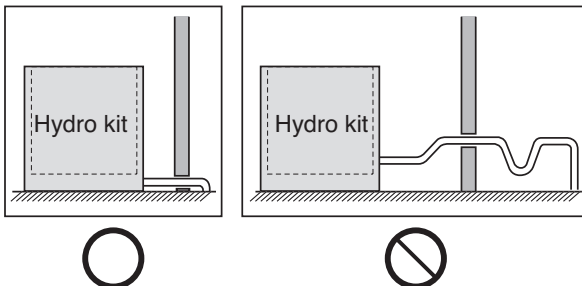

## Water Piping and Water Circuit Connection

### General Considerations

Followings should be considered before beginning water circuit connection.

- Service space should be secured.
- Water pipes and connections should be cleaned using water.
- Space for installing external water pump should be provided.
- Never connect electric power while proceeding water charging.

### Water Piping and Water Circuit Connection

While installing water pipes, followings should be considered :

- While inserting or putting water pipes, close the end of the pipe with pipe cap to avoid dust entering.
- When cutting or welding the pipe, always be careful that inner section of the pipe should not be defective. For example, no weldments or no burrs are found inside the pipe.
- Pipe fittings (e.g. L-shape elbow, T-shape tee, diameter reducer, etc) should be tightened strongly to be free from water leakage.
- Connected sections should be leakage-proof treatment by applying tefron tape, rubber bushing, sealant solution, etc.
- Appropriate tools and tooling methods should be applied to prevent mechanical breakage of the connections.
- Operation time of flow valve(e.g. 3way valve or 2way valve) should be less than 90 seconds.
- Pipe is insulated to prevent heat loss to external environment.

### Strainer

- Use the 30 mesh strainer. (Exclude scale diameter of 0.8 mm or less and other net)
- Check the strainer direction and assemble on the inlet hole (Refer to picture)
- Wrap the Teflon tape on the screw thread of the water pipe for more than 15 times for assembly.
- Install the service port facing downward. (Within left/right 45 degrees)
- Check if there is any leakage on the connecting part.
- Clean the strainer periodically. (Once a year or more frequent)

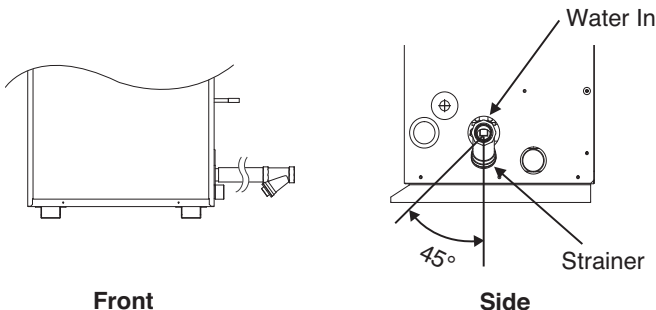

## Water cycle minimum requirements

1. For selecting the components of the hydraulic system, be sure they are above the design water pressure.
2. For the water pipe, diffusely tight water pipes are recommended instead of steel pipes.
3. For the drain pipe size, use the same diameter as the product connected or larger. Always install a natural drainage so that the drained water does not flows back
4. Install insulated material across the total hydraulic piping to prevent condensation and to prevent low cooling or heating capacity during heat transfer losses. If the temperature is higher than 30 °C and the humidity is higher than 80 % the insulation material must be minimum 20 mm thick to prevent condensation.
5. Install the shut-off valve (1) to block the water by closing the valve when replacing the component or cleaning.
6. Install an expansion tank (2) based on the water volume of the hydraulic system.
7. Install the drain valve (3) that can be used for draining the water inside when replacing the component or providing service.
8. Install a magnetic dirt separator (4) at the inlet water pipe. If the air separator is not installed there can be formed air bubbles inside the hydraulic system. Flow error will be showed first on remote controller, however finally a plate heat exchanger may burst during combined circumstances.
9. Install a circulation pump (5) which meets the water flow specifications mentioned inside product data book.
10. Install the strainer (6) at the inlet water pipe connection to protect the PHE. Do not charge water into the water pipe directly during Hydro Kit operation. If the strainer is not installed, component malfunction of Hydro Kit may occur.
  - For the strainer, use one with 30 mesh or above with measurement diameter of 0.8 mm or less.
  - Always install the strainer on the horizontal pipe.
11. Install a balancing valve (with flow meter) (8)
12. Install an automatic air separator in the outlet water pipe (9)
13. Install pressure safety relief valve (10) in vertical upright position that meets the design water pressure to prevent unit or water pipe damage during pressure increase inside the water pipe system.
14. Install a pressure meter (11) in the outlet water pipe.
15. Install in case of cascade hydraulic systems or bivalent systems a flow-check valve (12) at each outlet water pipe.
16. Install a buffer tank (13) of at least 10L/kW heating capacity in order to have a correct defrost cycle, if there is no knowledge about the type and dimensions of the heating system. If there is no buffer tank installed, the product can be damaged during normal operation or defrost operation.
17. After product operation for 2 weeks in case of new installation, clean the water filter. In the beginning of operation small particular dirt from installing process can block the filter which can lead to damage of the product.

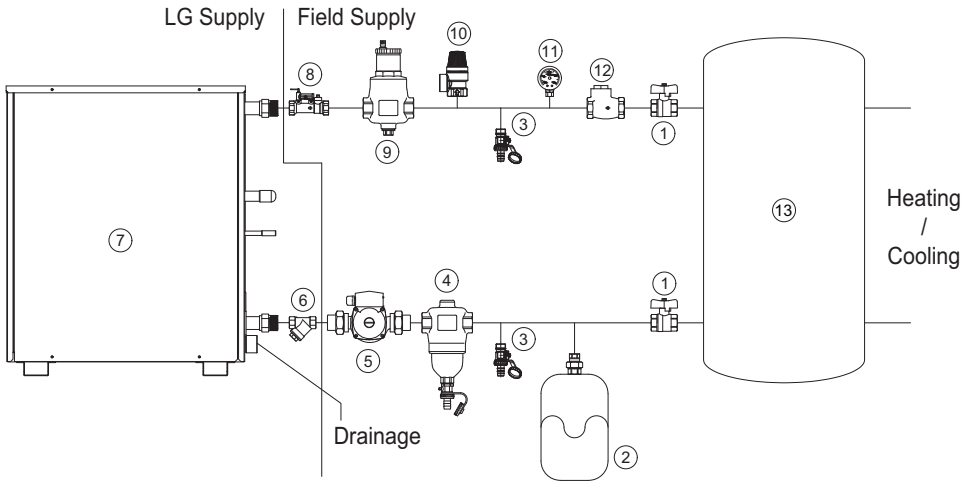

1	Shut-Off valve	8	Balancing valve with flow meter
2	Expansion tank	9	Automatic air separator
3	Service port(Drain valve)	10	Pressure safety relief valve
4	Magnetic filter(Recommended)	11	Pressure meter
5	Water Pump	12	Check valve
6	Strainer	13	Buffer tank / DHW <sup>1)</sup> (Sanitary Water) Tank
7	Flow switch (included in product)		

**NOTE**

Install the closed loop type water pipe system.

Balancing valve with flow meter is recommended to ensure 100 % of the nominal flow.

<sup>1)</sup> DHW : Domestic Hot Water.

## Installation Scenes

Installation scenes are presented for example.

Installer should optimize the installation scene according to the installation conditions and local/national regulation.

i.e. Shut-off valves position for spare water pump and water pump service, Flexible joint installation to prevent noise and vibration.

### 1) Space Heating/Cooling<sup>1)</sup> Installation

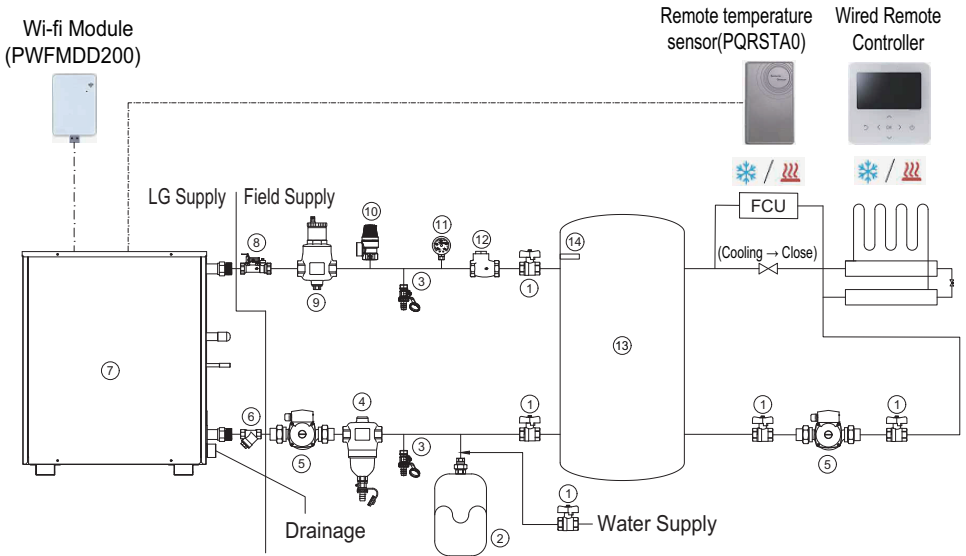

1	Shut-Off valve	8	Balancing valve with flow meter
2	Expansion tank	9	Automatic air separator
3	Service port(Drain valve)	10	Pressure safety relief valve
4	Magnetic filter (Mandatory with Corrosive material of pipe)	11	Pressure meter
5	Water Pump	12	Check valve
6	Strainer	13	Buffer Tank
7	Flow switch (included in product)	14	Water Tank temperature Sensor (12 m)

- For space heating / cooling, 'DIP switch #2' should be set correctly.
- For sensing air temperature at specific area, remote temperature sensor(PQRSTA0) or wired remote controller could be choose, depending on the 'DIP switch #3' setting.  
\*please refer the "System Set-Up, DIP Switch Setting"
- Wi-Fi module(PWFMDD200/105 cm) connected to 'CN-WF' on Hydro kit PCB. To increase the length between Wi-Fi modem and Hydro Kit, please purchase USB Extension Cable(PWYREW000, 10 m)
- In case of floor cooling, please make sure to set cooling cut off temperature for preventing condensation on the floor
- For 2 way valve control, please refer the "Accessories Installation, 2 Way valve"

Mode	Condition	2-way valve
Cooling	FCU – 'Not use'	Open
	FCU – 'Use'	Close
Heating	None	No control

**NOTE**

- Balancing valve with flow meter is recommended to ensure 100 % of the nominal flow. If the water flow rate is too low or High, PHEX could be frozen and burst or capacity could be reduced.
- 1) Cooling operation is only available for Medium temperature Hydro Kit.

## 2) Water Tank(DHW) Installation

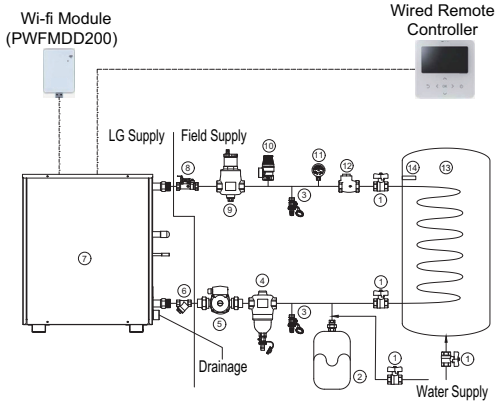

1	Shut-Off valve
2	Expansion tank
3	Service port(Drain valve)
4	Magnetic filter (Mandatory with Corrosive material of pipe)
5	Water Pump
6	Strainer
7	Flow switch (included in product)
8	Balancing valve with flow meter
9	Automatic air separator
10	Pressure safety relief valve
11	Pressure meter
12	Check valve
13	Buffer Tank
14	Water Tank temperature Sensor (12 m)

- For water tank(DHW) operation, DIP switch #2 in Hydro Kit PCB should be set correctly, please refer the "System Set-Up, DIP Switch Setting"
- Wi-Fi module(PWFMD200, 105 cm) is connected to 'CN-WF' on Hydro Kit PCB. To increase the length between Wi-Fi modem and Hydro Kit, please purchase USB Extension Cable(PWYREW000, 10 m)
- DHW(Sanitary water) tank should be located at the flat place.
- Water quality should comply with EN 98/83 EC Directives.
- DHW(Sanitary water) tank (indirect heat exchange), do not use anti water-freezing treatment like ethylene glycol.
- It is highly recommend to wash out inside of the DHW(Sanitary water) tank after installation for clean hot water.
- Near the DHW(Sanitary water) tank , there should be water supply and water drain for easy access and maintenance.

### Water tank temperature sensor(14) connection

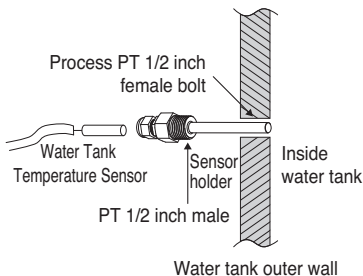

If hot water mode is used, make sure to install sensor to water tank.

- Make PT 1/2inch female bolt hole in the water tank and install sensor in the water tank.
- Push the sensor into the hole of the sensor holder cap.
- Lock the sensor holder cap.
- Maximum length of water tank temperature sensor is 12 m.

### 3) Water Tank(DHW) + Floor Heating Installation(Default)

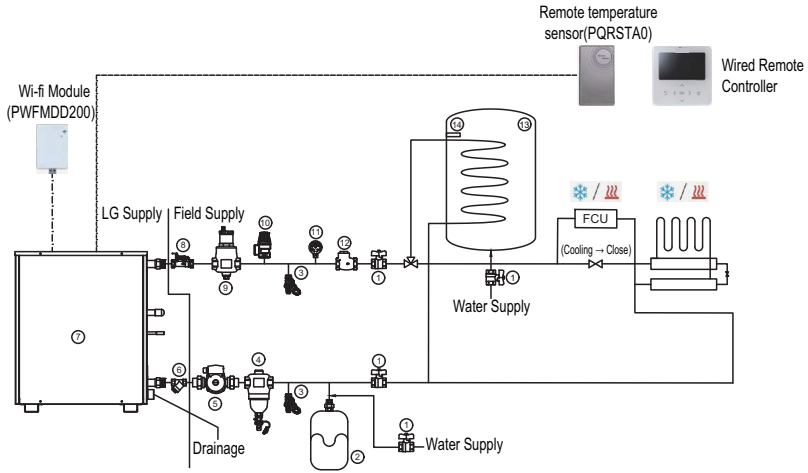

1	Shut-Off valve	8	Balancing valve with flow meter
2	Expansion tank	9	Automatic air separator
3	Service port(Drain valve)	10	Pressure safety relief valve
4	Magnetic filter(Recommended)	11	Pressure meter
5	Water Pump	12	Check valve
6	Strainer	13	DHW <sup>(1)</sup> (Sanitary Water) Tank
7	Flow switch (Included in product)	14	Water Tank temperature Sensor (12 m)

- For DHW / Floor Heating operation , 'DIP switch #2' should be set correctly.
- For sensing air temperature at specific area, remote temperature sensor(PQRSTA0) or wired remote controller could be choose, depending on the 'DIP switch #3' setting.  
\*please refer the "System Set-Up, DIP Switch Setting"
- Wi-Fi module(PWFMD200/105 cm) connected to 'CN-WF' on Hydro kit PCB. To increase the length between Wi-Fi modem and Hydro Kit, please purchase USB Extension Cable(PWYREW000, 10 m)
- In case of floor cooling, please make sure to set cooling cut off temperature for preventing condensation on the floor
- For 3-way, 2-way valve control, please refer the "Accessories Installation"

Mode	Condition	3-way valve direction	2-way valve
Cooling	FCU – 'Not use'	Under Floor	Open
	FCU – 'Use'	Under Floor	Close
Heating	Priority – 'DHW'	DHW / Sanitary Water Tank	No control
	Priority – 'UFH'	Under Floor	No control

#### NOTE

- The Heating operation mode of the hot water tank is not a mode selection by the remote controller, it changes the 3-way valve direction to Water Tank base on the water tank temperature.
- It is impossible to operate Hot water(DHW) during cooling mode.

## 4) Water Tank(DHW) + Floor Heating + Solar booster Installation

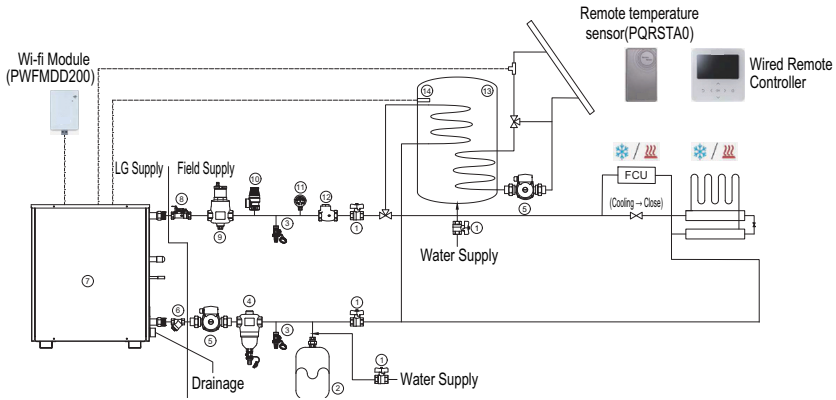

1	Shut-Off valve	9	Automatic air separator
2	Expansion tank	10	Pressure safety relief valve
3	Service port(Drain valve)	11	Pressure meter
4	Magnetic filter(Recommended)	12	Check valve
5	Water Pump	13	DHW <sup>1)</sup> (Sanitary Water) Tank
6	Strainer	14	Water Tank temperature Sensor (12 m)
7	Flow switch (Included in product)	15	Solar panel
8	Balancing valve with flow meter		

- For DHW / Floor Heating and Solar booster operation , 'DIP switch #2' should be set correctly.
- For sensing air temperature at specific area, remote temperature sensor(PQRSTA0) or wired remote controller could be choose, depending on the 'DIP switch #3' setting.  
\*please refer the "System Set-Up, DIP Switch Setting"
- Wi-Fi module(PWFMD200/105cm) connected to 'CN-WF' on Hydro kit PCB. To increase the length between Wi-Fi modem and Hydro Kit, please purchase USB Extension Cable(PWYREW000, 10 m)
- In case of floor cooling, please make sure to set cooling cut off temperature for preventing condensation on the floor
- DHW(Sanitary water) tank should be located at the flat place.
- Water quality should comply with EN 98/83 EC Directives.
- DHW(Sanitary water) tank (indirect heat exchange), do not use anti water-freezing treatment like ethylene glycol.
- It is highly recommend to wash out inside of the DHW(Sanitary water) tank after installation for clean hot water.
- Near the DHW(Sanitary water) tank , there should be water supply and water drain for easy access and maintenance.
- For 2-way or 3-way valve control, please refer the "Accessories Installation".

### **How to install Solar Thermal Kit(PHLLA)**

- Step 1.** Check the diameter of pre-installed pipes. (symbol Ⓐ and Ⓑ)
- Step 2.** If the diameter of pre-installed pipes is different from diameter of solar thermal kit, it is necessary to reduce or extend of pipe diameter.
- Step 3.** After Step 2, connect the pipe and solar thermal kit.
- Step 4.** Connect solar thermal sensor to 'CN\_TH4'(Red connector) of the indoor unit PCB.  
If the water tank sensor is connected, disconnect the sensor from PCB first.

#### **DHW tank, additional information**

If a Non-Stainless DHW tank is used there will be a coating inside the tank to protect this tank against corrosion.

The corrosion protection is done by an anode which is mounted inside the tank.

This anode is protecting the internal tank against corrosion which could lead to leakage and contaminated water inside the tank, the anode will increase the lifetime of the DHW tank.

#### **When to replace the anode?**

The lifetime of an anode itself is based on the water quality inside the country.

Depending on the used DHW tank, the tank can be equipped with an anode tester.

If the DHW does not have an anode tester manually the anode must be inspected and replaced every 3~5 years if needed.

#### **What is an anode?**

An anode protects the DHW tank against corrosion.

It consists of a bar of magnesium oxide.

A correct working anode is crucial to increase the lifetime of a Non-stainless steel DHW tank while it makes the tank cathodic and prevents against corrosion.

## ⚠ CAUTION

- If the unit is installed at existing hydraulic water loop, it is important to clean hydraulic pipes to remove sludge and scale.
- Installing sludge strainer in the water loop is very important to prevent performance degrade.
- Chemical treatment to prevent rust should be performed by installer.

## Freezing protection

### • For Medium Temperature

In areas of the country where entering water temperatures drop below 15 °C(59 °F), the water pipe must be protected by using an approved antifreeze solution. Consult your **Hydro Kit** unit supplier for locally approved solutions in your area. Calculate the approximate volume of water in the system. (Except the **Hydro Kit** unit.) And add antifreeze solution to the total volume to allow for the water contained in **Hydro Kit** unit.

Type of Antifreeze	Minimum Temperature for Freeze Protection					
	15 °C(59 °F) ~ -5 °C(23 °F)	-10 °C(14 °F)	-15 °C(5 °F)	-20 °C(-4 °F)	-25 °C(-13 °F)	
Ethylene glycol	12 %	20 %	30 %	-	-	
Propylene glycol	17 %	25 %	33 %	-	-	
Methanol	6 %	12 %	16 %	24 %	30 %	

### • For High Temperature

In areas of the country where entering water temperatures drop below 0 °C(32 °F), the water pipe must be protected by using an approved antifreeze solution. Consult your **Hydro Kit** unit supplier for locally approved solutions in your area. Calculate the approximate volume of water in the system. (Except the **Hydro Kit** unit.) And add antifreeze solution to the total volume to allow for the water contained in **Hydro Kit** unit.

Type of Antifreeze	Minimum Temperature for Freeze Protection					
	0 °C(32 °F)	-5 °C(23 °F)	-10 °C(14 °F)	-15 °C(5 °F)	-20 °C(-4 °F)	-25 °C(-13 °F)
Ethylene glycol	0 %	12 %	20 %	30 %	-	-
Propylene glycol	0 %	17 %	25 %	33 %	-	-
Methanol	0 %	6 %	12 %	16 %	24 %	30 %

## ⚠ CAUTION

1. Use only one of the above antifreeze.
2. If a antifreeze is used, pressure drop and capability degradation of the system can occur.
3. If one of antifreezes is used, corrosion can occur. So please add corrosion inhibitor.
4. Please check the concentration of the antifreeze periodically to keep same concentration.
5. When the antifreeze is used (for installation or operation), take care to ensure that antifreeze must not be touched.
6. Ensure to respect all laws and norms of your country about Anti-freeze usage.
7. When hydro kit is applied for cooling, the antifreeze must be added in the water circuit to prevent freezing.
8. Set the DIP S/W and short key to Anti Freeze mode only after the addition of brine(Anti-freeze). Or else the product may get damage due to freezing and bursting.

## ⚠ WARNING

Do not add brine(Anti-freeze) to the water circuit when it is used for hot water.

## Refrigerant Piping

### Cut the pipes and the cable

- Use the accessory piping kit or the pipes purchased locally.
- Measure the distance between the indoor and the outdoor unit.
- Cut the pipes a little longer than measured distance.
- Cut the cable 1.5 m longer than the pipe length.

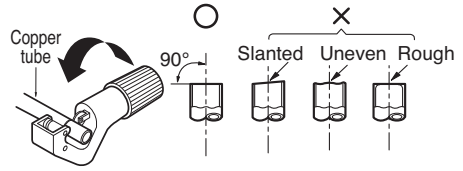

### Burrs removal

- Completely remove all burrs from the cut cross section of pipe/tube.
- Put the end of the copper tube/pipe to downward direction as you remove burrs in order to avoid to let burrs drop in the tubing.

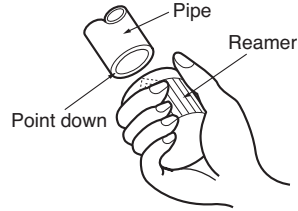

### Pipe welding

- Insert and weld the pipe.
- Always make sure to flow Nitrogen at 0.2 kgf/cm<sup>2</sup> within the pipe when welding.
- If the welding is done without flowing Nitrogen, it can generate a thick oxidized coating within the pipe to interfere with normal operation of valve and compressor etc.

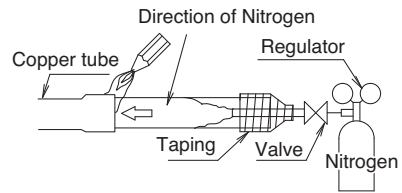

### Insulation

- Use rubber foamed insulation material (EPDM, NBR) with high thermal resistance.
- When installed in humid environment, use thicker insulation material than usual.
- Insert the insulation material within the product as deep as possible.

Classification	Thickness
Liquid pipe(Ø 9.52)	t 9 or above
Gas pipe(Ø 22.2 - 10 HP Ø 15.88 - 4 HP)	t 19 or above

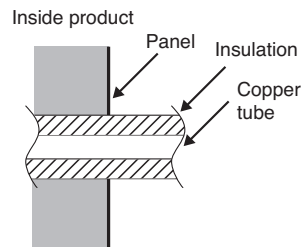

※ The thickness of the above insulation material is based on thermal conduction rate of 0.036 W/m °C.

## Connecting Heat Recovery systems

PRHR042 / PRHR032 / PRHR022

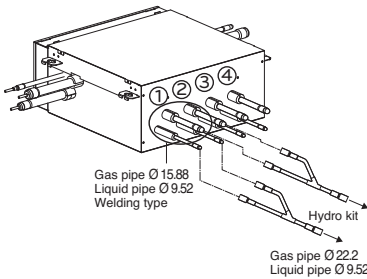

- One connection of refrigerant pipe for HR unit is insufficient for the flow of refrigerant. Join two pipes with a branch pipe when connecting the **Hydro Kit** (Up to 16 kW (54 kBtu/h) capacity model: 8, 10 HP).
- The pipe number of the connected gas pipe and liquid pipe must be same.
- Flow water in the **Hydro Kit** when pipe-searching process is performed.
- Pipe-searching process error may occur if the pipe temperature does not increase.
- It is recommended that **Hydro Kit** (8, 10 HP model) is connected to No.1 valve and No.2 valve.

	DIP S/W setting	Example
Not control		
No.1, 2 Valve Control		
No.2, 3 Valve Control		
No.3, 4 Valve Control		
No.1, 2 Valve / No.3, 4 Valve Control		

### Precaution on pipe searching process

1. Please choose the 'Mode' according to the water temperature
  - Use 'Mode 1' if water temperature is higher than 30 °C(86 °F)
  - Use 'Mode 2' if water temperature is lower than 30 °C(86 °F)
2. Be sure that water pump is operating during the pipe searching process
  - If the water circulation is not detected by water flow switch, 'CH14' error will occur.



For more detailed information, refer to the installation manual of Heat Recovery Unit.

## Connecting Heat Recovery systems

PRHR083 / PRHR063 / PRHR043 / PRHR033 / PRHR023

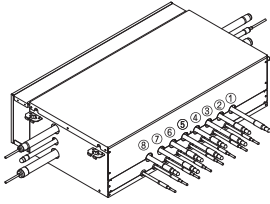

- One connection of refrigerant pipe for HR unit is insufficient for the flow of refrigerant. Join two pipes with a branch pipe when connecting the **Hydro Kit** (Up to 61 kBTu/h capacity model: 8, 10 HP).
- The pipe number of the connected gas pipe and liquid pipe must be same.
- Flow water in the **Hydro Kit** when pipe-searching process is performed.
- Pipe-searching process error may occur if the pipe temperature does not increase.
- It is recommended that **Hydro Kit** (8, 10 HP model) is connected to No.1 valve and No.2 valve.

Valve Group	SW01D Setting	Valve Group	SW01D Setting
Not control	0	No. 5,6/7,8 Valve Control	8
No. 1,2 Valve Control	1	No. 1,2/5,6 Valve Control	9
No. 2,3 Valve Control	2	No. 1,2/7,8 Valve Control	A
No. 3,4 Valve Control	3	No. 3,4/5,6 Valve Control	B
No. 5,6 Valve Control	4	No. 3,4/7,8 Valve Control	C
No. 6,7 Valve Control	5	No. 1,2/3,4/5,6 Valve Control	D
No. 7,8 Valve Control	6	No. 1,2/3,4/6,7 Valve Control	E
No. 1,2/3,4 Valve Control	7	No. 1,2/3,4/7,8 Valve Control	F

### Note:



SW01D (Rotary SW) : Selection of the Valve Group Control

## Precaution on pipe searching process

1. Please choose the 'Mode' according to the water temperature
  - Use 'Mode 1' if water temperature is higher than 30 °C(86 °F)
  - Use 'Mode 2' if water temperature is lower than 30 °C(86 °F)
2. Be sure that water pump is operating during the pipe searching process
  - If the water circulation is not detected by water flow switch, 'CH14' error will occur.



For more detailed information, refer to the installation manual of Heat Recovery Unit.

## How to connect wirings

### • For Medium Temperature

Remove the box cover of electric parts and connect the wiring.

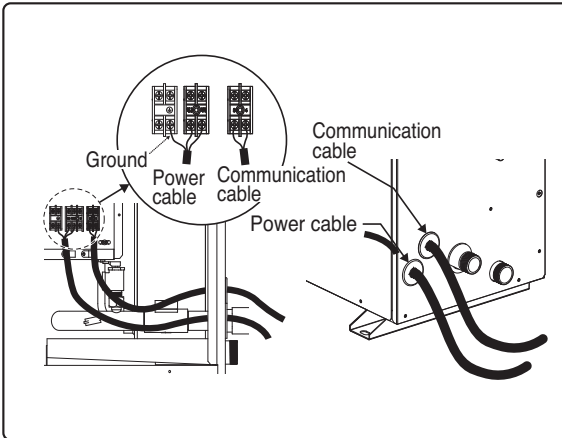

### ⚠ CAUTION

When connecting the power and communication cable, always use the terminal connector (O-ring, Y-ring).

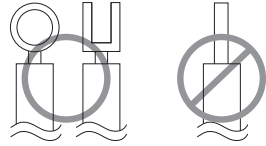

Make sure to tighten so that the screw of the terminal does not get loose.

### • For High Temperature

Remove the box cover of electric parts and connect the wiring.

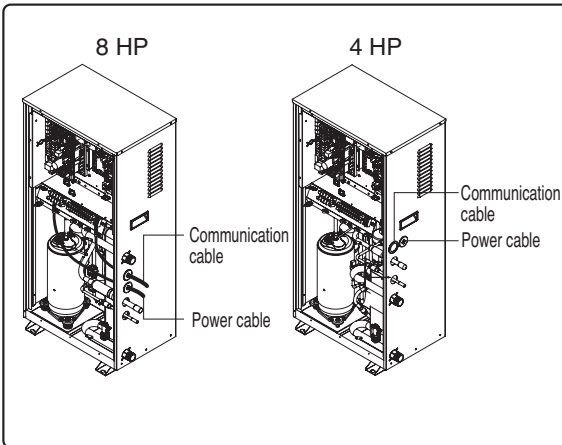

### ⚠ CAUTION

When connecting the power and communication cable, always use the terminal connector (O-ring, Y-ring).

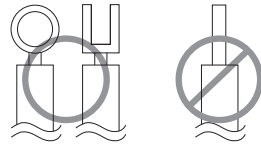

Make sure to tighten so that the screw of the terminal does not get loose.

## Wiring Connection

Connect the wires to the terminals on the control board individually according to the outdoor unit connection.

- Ensure that the wire color of the outdoor unit and terminal No. are same as those of the indoor unit respectively.
- The installation of a residual current device(RCD) having a rated residual operating current not exceeding 30 mA is advisable.

### • For Medium Temperature

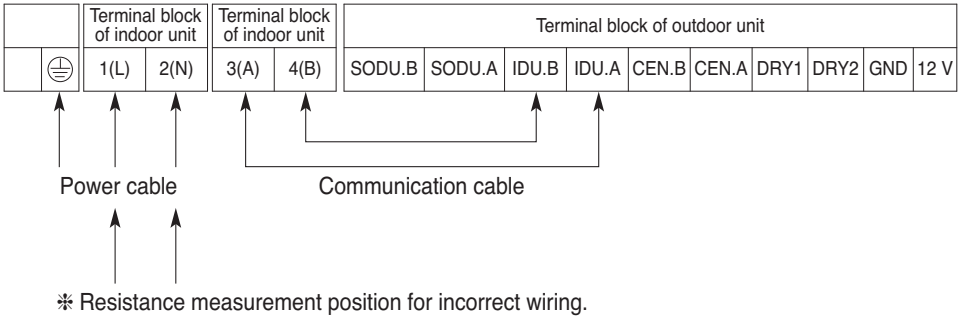

### • For High Temperature

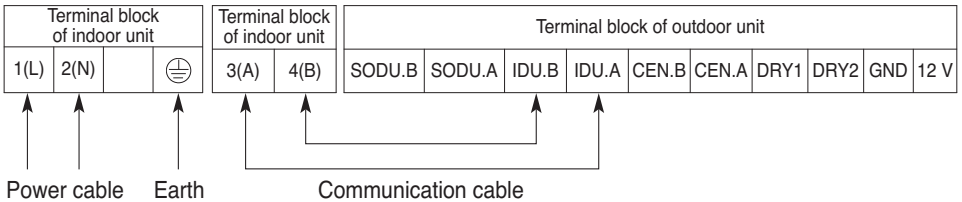

## ⚠ WARNING

Make sure that the screws of the terminal are free from looseness.

## ⚠ CAUTION

Be sure to test the power line and communication line for incorrect wiring before power is applied.

- 1) If the power line and communication line are swapped over, the product will be damaged.
- 2) Incorrect wiring confirmation test method : Measure the resistance across the power terminals (L,N) using a multi meter.
  - Resistance value of a normal connection: 1 MΩ or more
  - Incorrect wiring resistance value: 500 mΩ or less

## **⚠ CAUTION**

**After the confirmation of the above conditions, prepare the wiring as follows:**

1. Use a separate power source only for the air conditioner.  
For the method of wiring, follow the circuit diagram on the inner side of control box cover.
2. Install a circuit breaker between power source and the unit.
3. Make sure that wiring screws are fastened. Screw could be loose by vibration during transportation. (If screws are loose, wires could be burnt-out)
4. Check the Specification of power source
5. Make sure the electrical capacity is sufficient.
6. Starting voltage should be maintained above 90 percent of the rated voltage marked on the name plate.
7. Make sure the cable thickness matches the power sources specification.  
(Please note the relation between cable length and thickness.)
8. Do not install the earth leakage breaker in a place which is wet or moist.  
Water or moisture may cause a short circuit.
9. The following troubles could be caused by voltage drop-down.
  - Vibration of a magnetic switch, damage on the contact point there of, (fuse breaking), disturbance to the normal function of a an overload protection device.
  - Proper starting power is not given to the compressor.
10. Before supplying power to the indoor unit, please check the wiring of the power and communication lines.
11. If the supply cord is damaged, it must be replaced by the manufacturer, its service agent or similarly qualified persons in order to avoid a hazard.

### • Rating of circuit breakers

	The thickness of Minimum wire (mm <sup>2</sup> )		Leakage circuit breaker
	Main power wire	Ground wire	
1 Unit	2.5 ~ 6	2.5	< 30 ~ 50 A 100 mA 0.1 S
2 Unit	10 ~ 16	2.5	< 75 ~ 100 A 100 mA 0.1 S
3 Unit	25 ~ 35	4	< 125 ~ 150 A 100 mA 0.1 S
4 Unit	70	6	< 175 ~ 200 A 100 mA 0.1 S

## Connecting Cables

### Types of the cables

Classification	types	Cable cross section
Power cable(CV)	mm <sup>2</sup> x cores	4.0 x 3
Communication cable(VCTF-SB)	mm <sup>2</sup> x cores	1.0~1.5 x 2

### The distance between communication cable and power cable

- If the power cable and communication cable are tied together, system malfunction may occur with electrostatic, electromagnetic combination effect causing the interference signal. If communication cable is connected along with power cable, secure at least 50 mm distance between indoor unit power cable and communication cable.

It is the value with the assumption of the length of the parallel cable as 100 m. If it is longer than 100 m, it shall be calculated again with proportional to the added length.

If the distortion in the waveform of the power still occurs despite securing the distance, increase the distance.

※ When several power cables are inserted into the transmission line, or tied together, make sure to consider the following issues.

- Power cables and communication cable shall not be in the same transmission line.
- Power cables and communication cable shall not be tied together.

### WARNING

- Are all of the indoor units and outdoor units grounded?
- If grounding is not properly done, there is a risk of electric shock. Grounding must be done by a qualified technician.
- Consider the surrounding conditions(surrounding temperature, direct sunlight, rain water, etc.) when wiring the cable.
- The thickness of the power cable is the minimum thickness of metal conductor cable. Use thicker cable considering the voltage drop.

## Installation of Wired Remote Controller

### 1. Please fix tightly using provided screw after placing remote controller setup board on the place where you like to setup.

- Please set it up not to bend because poor setup could take place if setup board bends. Please set up remote controller board fit to the reclamation box if there is a reclamation box.
- Install the product so as not to make a gap with the wall side and to prevent shaking after the installation.

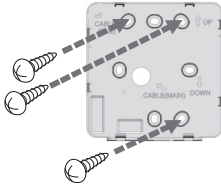

<4 socket reclamation box installation>

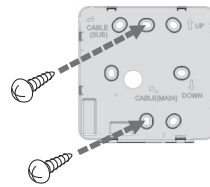

<2 socket reclamation box installation>

### 2. Can set up Wired remote controller cable into three directions.

- Setup direction: the surface of wall reclamation, upper, right
- If setting up remote controller cable into upper and right side, please set up after removing remote controller cable guide groove.
- \* Remove guide groove with long nose.
- Reclamation to the surface of the wall.

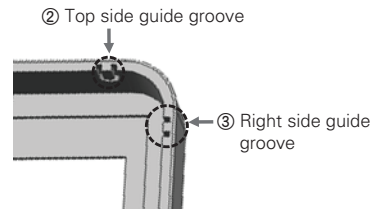
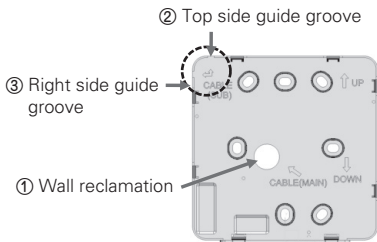

### 3. Please fix remote controller upper part into the setup board attached to the surface of the wall, as the picture below, and then, connect with setup board by pressing lower part.

- Please connect not to make a gap at the remote controller and setup board's upper and lower, right and left part.
- Before assembly with the installation board, arrange the Cable not to interfere with circuit parts.

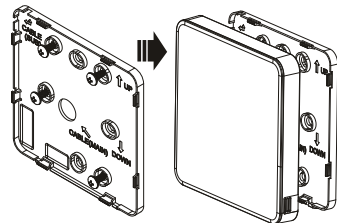

4. When separating remote controller from setup board, as the picture below, after inserting into the lower separating hole using screw driver and then, spinning clockwise, remote controller is separated.

- There are two separating holes. Please individually separate one at a time.
- Please be careful not to damage the inside components when separating.

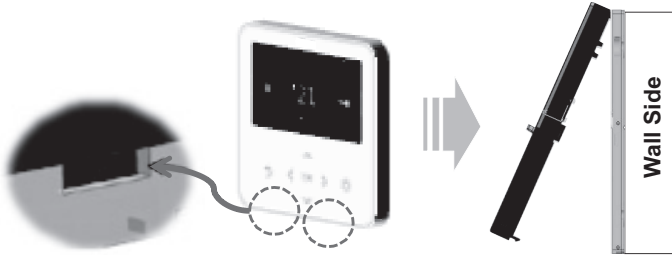

5. Please connect indoor unit and remote controller using connection cable.

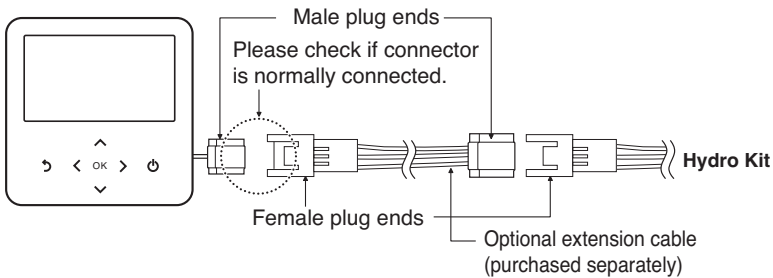

6. Please use extension cable if the distance between wired remote controller and indoor unit is more than 10 m.

Extension cable(10 m) model name : PZCWRC1

## **⚠ CAUTION**

When installing the wired remote controller, do not bury it in the wall.  
(It can cause damage in the temperature sensor.)

Do not install the cable to be 50 m or above. (It can cause communication error.)

- When installing the extension cable, check the connecting direction of the connector of the remote controller side and the product side for correct installation.
- If you install the extension cable in the opposite direction, the connector will not be connected.
- Specification of extension cable: 2547 1007 22# 2 core 3 shield 5 or above.

# Accessories Installation

## Location of Accessories and External Parts Connection

### • For Medium Temperature

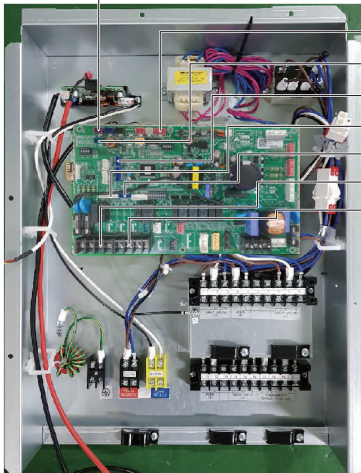

- Refrigerant leak detector locking location (CN-LEAK-ROOM2)
- Water tank temperature sensor locking location (CN-TH4)
- Remote controller locking location (CN-REMO)
- Wi-Fi module locking location (CN-WF)
- Dry contact board locking location (CN-CC)
- External PCB locking location (CN-EXT)
- SG ready connecting location (TB-SG)
- External pump connecting location (TB-EXT-PUMP)

3WAY VALVE (B)			PUMP(B) (Solar)				3WAY VALVE (A)		
1 L	2 L1	3 N	4 L	5 N	6	7	8 L	9 L1	10 N
BR	WH	BL	BR	BL			BR	WH	BL

PUMP(A) (Hydro kit)			2WAY VALVE (A)			THERMOSTAT (Default : 230 V AC)			
11	12	13	14	15	16	17	18	19	20
L	N		L1	L2	N	L	N	L1	L2
BR	BL		BR	WH	BL	BR	BL	WH	BK

### • For High Temperature

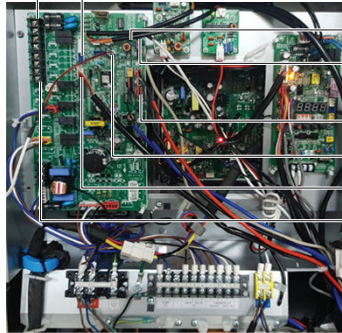

- SG ready connecting location (TB-SG)
- External PCB locking location (CN-EXT)
- Remote controller locking location (CN-REMO)
- Refrigerant leak detector locking location (CN-LEAK-ROOM2)
- Water tank temperature sensor locking location (CN-TH4)
- Wi-Fi module locking location (CN-WF)
- Dry contact board locking location (CN-CC)
- External pump connecting location (TB-EXT-PUMP)

L	N		L	L1	N	L	N	L1	L2
PUMP(A) (Hydro kit)			3WAY VALVE (A)			THERMOSTAT (Default : 230 V AC)			

- Connect 3way valve, if both floor heating and hot water is used.
- Connect the separately purchased thermostat.
- Dry contact is an accessory supplied by LG and installed by referring to the attached installation manual.
- 3way valve, thermostat and pump are external parts for installation, which are not supplied by LG. After checking each part carefully, install external parts respectively.
- Connect the cable of each accessory to the terminal block of the control box in the **Hydro Kit**.
- Check the label attached on the terminal block to prevent wrong connection.
- Use the pump of 220 ~ 240 voltage and maximum operation current of 3 A or less.
- Select a suitable relay for pump capacity when connecting the pump to the unit.

## WARNING

Install the unit after turning off the main power.  
Do not connect the products out of range specified in the manual.  
Do not work with wet hand.

Name	Port	Electrical Spec	Function
3way valve (Hydro kit)	Terminal Block - Mid Temp : #8 / #9 / #10 - High Temp : #4 / #5 / #6	230V(output) - Live : #8 / #9 (#4/ #5) - Neutral : #10 (#6)	Change the water flow to Water tank or Floor circuit
2way valve (Hydro kit)	Terminal Block - Mid Temp : #14 / #15 / #16	230V(output) - Live : #14 / #15 - Neutral : #16	Change water flow to FCU or Floor Circuit
Pump (Hydro kit)	Terminal Block - Mid Temp : #11 / #12 - High Temp : #1 / #2	230V(output) - Live : #11 (#1) - Neutral : #12 (#2)	Water circulation
3way valve (Solar)	Terminal Block - Mid Temp : #1 / #2 / #3	230V (output) - Live : #1 / #2 - Neutral : #3	Change the water flow to Solar or Water tank circuit
Water Pump (Solar)	Terminal Block - Mid Temp : #4 / #5	230V(output) - Live : #4 - Neutral : #5	Water circulation for solar water piping system
Thermostat	Terminal Block - Mid Temp : #17 / #18 / #19 / #20 - High Temp : #7 / #8 / #10	230V or 24V - Live : #17 (#7) - Neutral : #18 (#8) - Signal : #19 / #20 (#10)	Operating with Thermostat (Mechanical)
Water Tank Temperature Sensor	CN_TH4	NTC 5 kΩ, 12 m	Detect water temperature in water tank
Remote Room Temperature Sensor (PQRSTA0)	CN_ROOM	NTC 10 kΩ, 15 m	Detect Air temperature in Room
Wi-Fi (PWFMD200)	CN_WF	DC 12 V, 5 m	Control with Mobile app
External on/off Control	CN_EXT	Non-Voltage (Digital input)	Operation on/off with external device.
Dry Contact	CN_CC	Non-Voltage (input)	Dry contact connection point
Refrigerant Leak detection	CN_LEAK_ROOM2	DC 5 V, 35 mA, 10 m	Detect refrigerant leakage
Smart Grid	TB SG2 , TB SG1	220 ~ 240 V AC [Input]	
External pump	TB EXT_PUMP	Non-Voltage [output] / 1 A	Interlock with external pump by relay

## Main Pump Connection

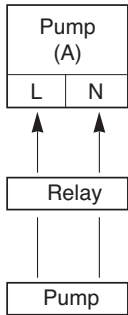

- Select the suitable pump by referring to the flow rate table with water temperature difference between the entrance and the exit.
- It is recommended that the flow rate is Rated water flow (refer to the specification of PDB)
- Use the pump with enough capacity to guarantee the loss of entire water pressure and to supply the **Hydro Kit** with water.
- Select a suitable relay for pump capacity when connecting the pump to the unit.
- Connect the relay to the terminal block Pump(A) of the control box.

### ⚠ CAUTION

- Make sure to supply external power with the pump.

## Water tank temperature sensor Connection

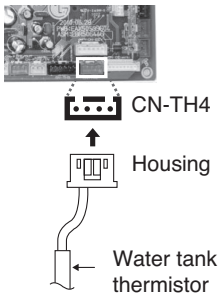

- Water tank temperature sensor is needed for hot water mode.
- Connect sensor housing to PCB 'CN-TH4' connector (red).
- To activate hot water mode, DIP S/W should be set #2, #3 according to DIP Switch Setting.

### ⚠ CAUTION

- When the water tank temperature sensor is disconnected or shorted, CH08 error will occur.
- In case of floor heating mode, water tank temperature sensor doesn't need to be connected.

## Thermostat

Thermostat is generally used to control the unit by air temperature. When thermostat is connected to the unit, the unit operation is controlled by the thermostat.

### Installation Condition

#### ⚠ CAUTION

1. Use 230 V AC Thermostat.
2. Some electro-mechanical type thermostat has internal delay time to protect compressor. In that case, mode change can takes time more than user's expectation. Please read thermostat manual carefully if the unit does not response quickly.
3. Setting temperature range by thermostat can be different with that of the unit. The heating set temperature should be chosen within the setting temperature range of the unit.
4. It is highly recommended that the thermostat should be installed where space heating is mainly applied.

#### Following location should be avoid to secure proper operation :

- Height from floor is approximately 1.5 m.
- Thermostat can not be located where the area may be hidden when door is open.
- Thermostat can not be located where external thermal influence may be applied. (such as above heating radiator or open window)

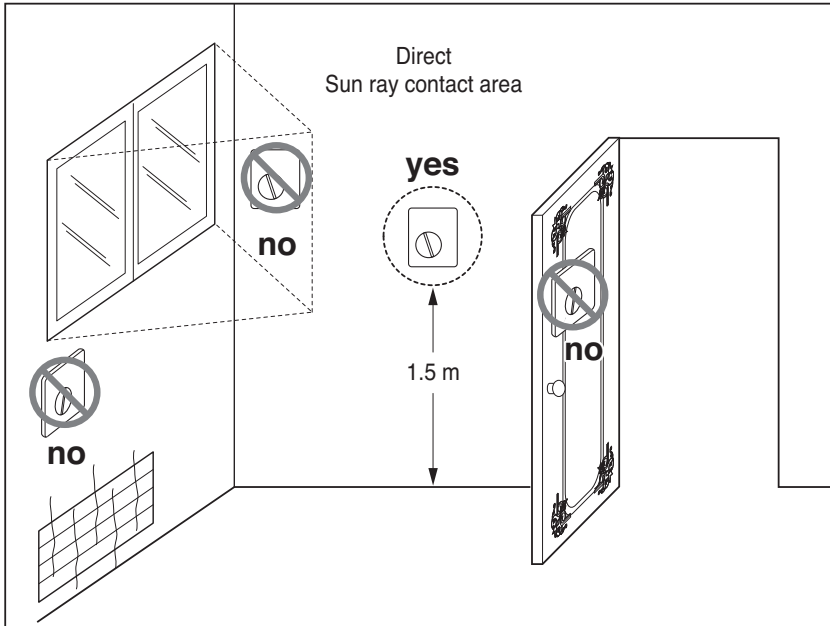

## General Information

**Hydro Kit** supports following thermostats.

Type	Power	Operating Mode	Supported (Medium Temperature)	Supported (High Temperature)
Mechanical (1)	230 V AC	Heating Only (3)	Yes	Yes
		Heating / Cooling (4)	Yes	No
	24 V AC	Heating Only (3)	Yes	No
		Heating / Cooling (4)	Yes	No
Electrical (2)	230 V AC	Heating Only (3)	Yes	Yes
		Heating / Cooling (4)	Yes	No
	24 V AC	Heating Only (3)	Yes	No
		Heating / Cooling (4)	Yes	No

- (1) There is no electric circuit inside the thermostat and electric power supply to the thermostat is not required.
- (2) Electric circuit such as display, LED, buzzer, etc is included in the thermostat and electric power supply is required.
- (3) Thermostat generates "Heating ON or Heating OFF" signal according to user's heating target temperature.
- (4) Thermostat generates both "Heating ON or Heating OFF" and "Cooling ON or Cooling OFF" signal according to user's heating and cooling target temperature.

### CAUTION

#### Choosing Heating / Cooling Thermostat

- Heating / Cooling Thermostat must have "Mode Selection" feature to distinguish operation mode.
- Heating / Cooling Thermostat must be able to assign heating target temperature and cooling target temperature differently.
- If above conditions are not kept, the unit can not operation properly.
- Heating / Cooling Thermostat must send cooling or heating signal immediately when temperature condition is satisfied. No delay time while sending cooling or heating signal is permitted.

## How to Wire Thermostat

Follow below procedures Step 1 ~ Step 6.

**Step 1.** Uncover front cover of the unit and open the control box.

**Step 2.** Identify the power specification of the thermostat. If it is 230 V AC, go to Step 4. Otherwise, if it is 24 V AC, go to step 3.

**Step 3.** Find thermostat connecting cable A and C. Disconnect cable A and C, then connect cable B and C.

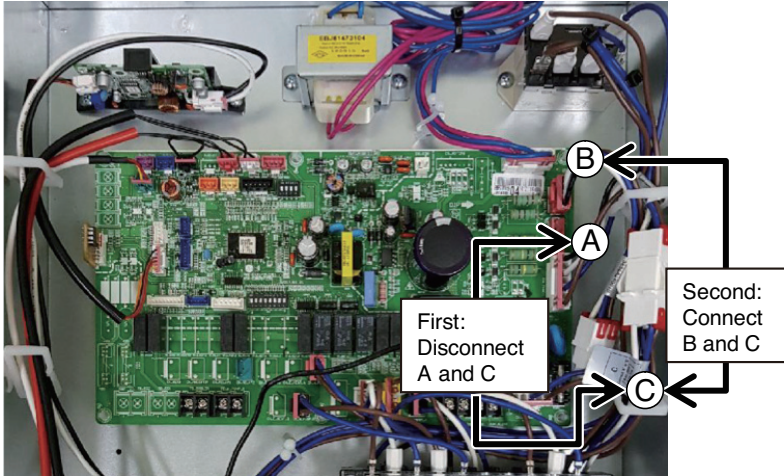

**Step 4.** If it is Heating Only Thermostat, go to step 5. Otherwise, if it is Heating / Cooling Thermostat, go to step 6.

**Step 5.** Find terminal block and connect wire as below. After connecting, go to step 6.

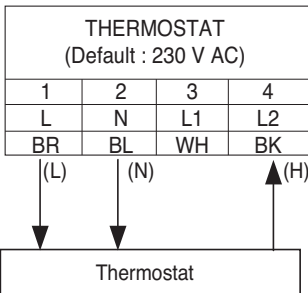

### **WARNING**

#### **Mechanical type Thermostat.**

Do not connect wire (N) as mechanical type thermostat does not require electric power supply.

### **CAUTION**

#### **Do not connect external electric loads.**

Wire (L) and (N) should be used only for operation Electric type thermostat.

Never connect external electric loads such as valves, fan coil units, etc. If connected, Main PCB Assembly 1 can be seriously damaged.

(L) : Live signal from PCB to Thermostat

(N) : Neutral signal from PCB to Thermostat

(H) : Heating signal from Thermostat to PCB

**Step 6.** Find terminal block and connect wire as below.

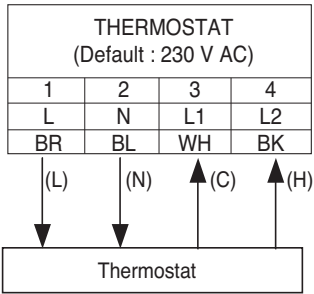

## ⚠ WARNING

### Mechanical type Thermostat.

Do not connect wire (N) as mechanical type thermostat does not require electric power supply.

## ⚠ CAUTION

### Do not connect external electric loads.

Wire (L) and (N) should be used only for operation Electric type thermostat.

Never connect external electric loads such as valves, fan coil units, etc. If connected, Main PCB Assembly 1 can be seriously damaged.

(L) : Live signal from PCB to Thermostat

(N) : Neutral signal from PCB to Thermostat

(C) : Cooling signal from Thermostat to PCB

(H) : Heating signal from Thermostat to PCB

## Final Check

- DIP switch setting :  
Set DIP switch No. 8 to 'ON' (Check the system set-up of Chapter 7). Otherwise, the unit can not recognize the thermostat.
- Remote Controller :
  - 'Thermostat' text is displayed on the remote controller.
  - Button input is prohibited.

## Remote Temperature Sensor

Remote temperature sensor can be installed any place a user wants to detect the temperature.

### How to Install Remote Temperature Sensor

**Step 1.** After deciding where the remote temperature sensor is installed, decide the location and height of the fixing screws. (Interval between the screws : 60 mm)

**Step 2.** Insert the connector of the connection wire into the space for the connector in place of the room temperature sensor.(CN\_ROOM)

**Step 3.** Separately, set the option code of the attached controller on the indoor unit.  
In detail, refer to "installer setting mode".

**Step 4.** The Connection wire does not matter if you change the color of the wire because of non-polar.

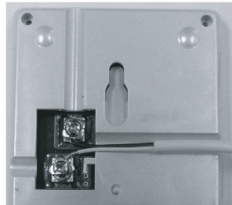
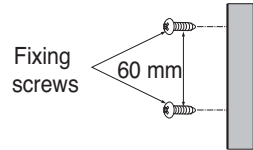

**Step 5.** Integrate the remote temperature sensor with the screws as the order of arrows.

Fixing the Remote Sensor

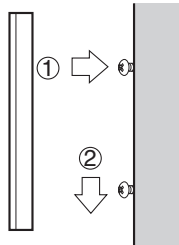

### ⚠ CAUTION

1. Choose the place where the average temperature can be measured for the indoor unit operates.
2. Avoid direct sunlight.
3. Choose the place where the heating devices do not affect the remote sensor.
4. Choose the place where the outlet of the cooling fan do not affect the remote sensor.
5. Choose the place where the remote sensor isn't affected when door is open.

## 3Way Valve

3way valve is required to operate sanitary water tank. Role of 3way valve is flow switching between under floor heating loop and water tank heating loop.

### General Information

**Hydro Kit** supports following 3way valve.

Type	Power	Operating Mode	Supported
SPDT 3-wire (1)	230 V AC	Selecting "Flow A" between "Flow A" and "Flow B" (2)	Yes
		Selecting "Flow B" between "Flow A" and "Flow B" (3)	Yes

(1) SPDT = Single Pole Double Throw. Three wires consist of Live (for selecting Flow A), Live 1 (for selecting Flow B), and Neutral (for common).

(2) Flow A means 'water flow from the unit to sanitary water tank'

(3) Flow B means 'water flow from the unit to under floor water circuit'

### How to Wire 3Way Valve

Follow below procedures Step 1 ~ Step 2.

**Step 1.** Uncover front cover of the unit and open the control box.

**Step 2.** Find terminal block and connect wire as below.

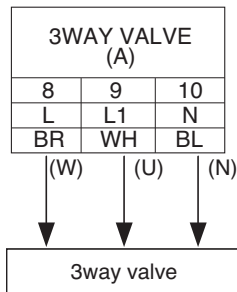

### ⚠ WARNING

- 3way valve should select water tank loop when electric power is supplied to wire (W) and wire (N).
- 3way valve should select under floor loop when electric power is supplied to wire (U) and wire (N).

(W) : Live signal (Water tank heating) from PCB to 3way valve

(U) : Live signal (Under floor heating) from PCB to 3way valve

(N) : Neutral signal from PCB to 3way valve

### ⚠ WARNING

Mice can not be appeared to prevent entering the unit or attacking wires.

## Final Check

- Flow direction :
  - Water should flow from water outlet of the unit to sanitary tank water inlet when sanitary tank heating is selected.
  - To verify the flow direction, check temperature at the water outlet of the unit and water inlet of sanitary water tank.
  - If correctly wired, these temperatures should be almost equivalent if thermal insulation of water pipe is well performed.
  
- Noise or water pipe vibration while 3way valve operation
  - Due to surging effect or cavitation effect, noise or water pipe vibration can be occurred while 3way valve is operating.
  - In that case, check followings :
    - Is water circuit (both under floor water loop and sanitary water tank loop) fully charged? If not, additional water charging is required.
    - Fast valve operation yields noise and vibration. Appropriated valve operating time is 60~90 seconds.

## 2Way Valve

2way valve is required to control water flow while cooling operation. Role of 2way valve is to cut off water flow into under floor loop in cooling mode when fan coil unit is equipped for cooling operation.

### General Information

**Hydro Kit** supports following 2way valve.

Type	Power	Operating Mode	Supported
NO 2-wire(1)	230 V AC	Closing water flow	Yes
		Opening water flow	Yes
NC 2-wire(2)	230 V AC	Closing water flow	Yes
		Opening water flow	Yes

(1) : Normal Open type. When electric power is NOT supplied, the valve is open.  
(When electric power is supplied, the valve is closed.)

(2) : Normal Closed type. When electric power is NOT supplied, the valve is closed.  
(When electric power is supplied, the valve is open.)

### How to Wire 2Way Valve

Follow below procedures Step 1 ~ Step 2.

**Step 1.** Uncover front cover of the indoor unit and open the control box.

**Step 2.** Find terminal block and connect wire as below.

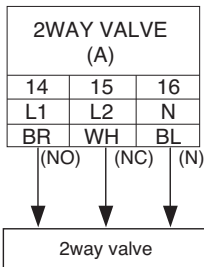

### CAUTION

#### Dew Condensation

- Wrong wiring can yield dew condensation on the floor. If radiator is connected at the under floor water loop, dew condensation can be occurred on the surface of the radiator.

### WARNING

#### Wiring

- Normal Open type should be connected to wire (NO) and wire (N) for valve closing in cooling mode.

(NO) : Live signal (for Normal Open type) from PCB to 2way valve

(NC) : Live signal (for Normal Closed type) from PCB to 2way valve

(N) : Neutral signal from PCB to 2way valve

### Final Check

- Flow direction :
  - Water should not flow into under floor loop in cooling mode.
  - To verify the flow direction, check temperature at the water inlet of the under floor loop.
  - If correctly wired, this temperatures should not be approached to 6 °C(42 °F) in cooling mode.

## Dry Contact

LG Dry Contact is a solution for automatic control of HVAC system at the owner's best. In simple words, it's a switch which can be used to turn the unit On/Off after getting the signal from external sources like key-in lock, door or window switch etc specially used in Hotel rooms.

### How to Install Dry Contact

Connect CN\_DRY with Control Unit.

- To apply power source through Dry Contact PCB.

#### PDRYCB100

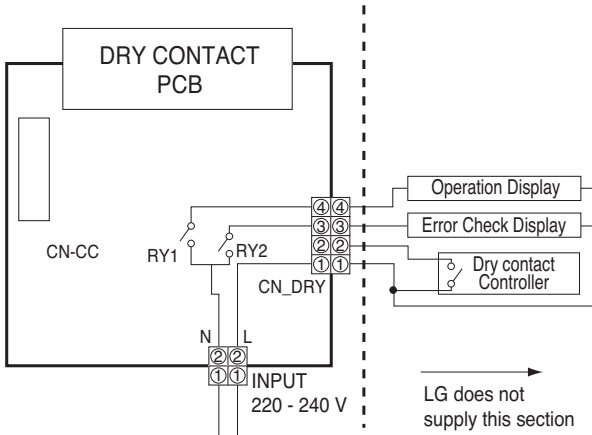

- To apply power source directly to external source.

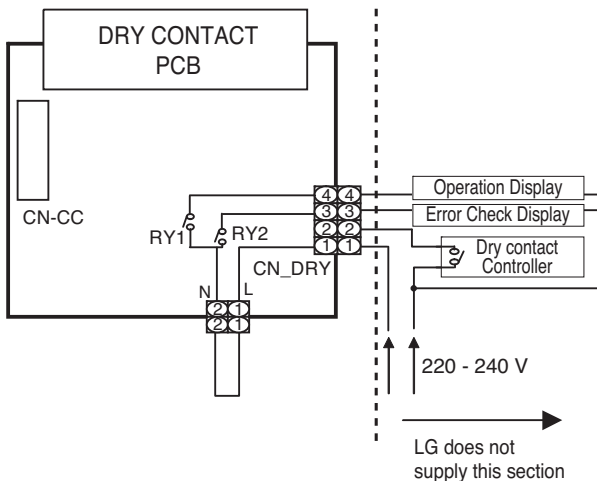

# Setting of Contact Signal Input

## PDRY300

### ■ For input contact closure only(No power input)

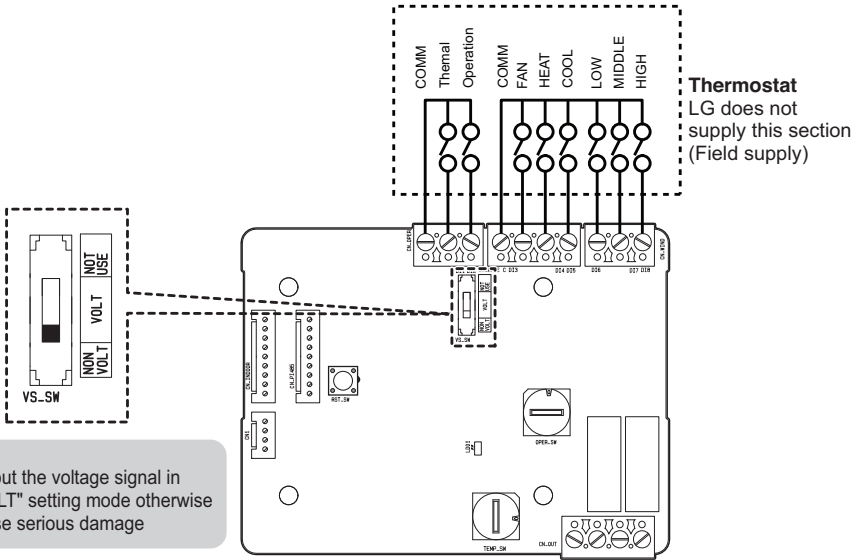

### ■ For input contact voltage : DC 12 V, AC 24 V

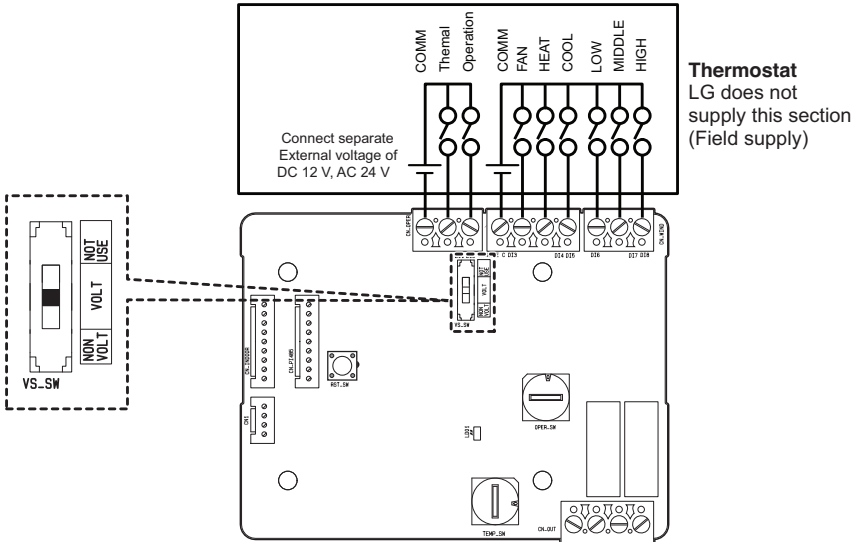

## External Controller

If you require to operate control depending on external digital input(ON/OFF), connect cable to indoor PCB(CN\_EXT).

Follow below procedures step 1 ~ step 4.

**Step 1.** Check if the power of the unit is turned off.

**Step 2.** Disassemble front panels and distinguish control box(Indoor) of the unit

**Step 3.** Connect the external controller to PCB(CN\_EXT) completely.

**Step 4.** Connect the cable and field installation part.

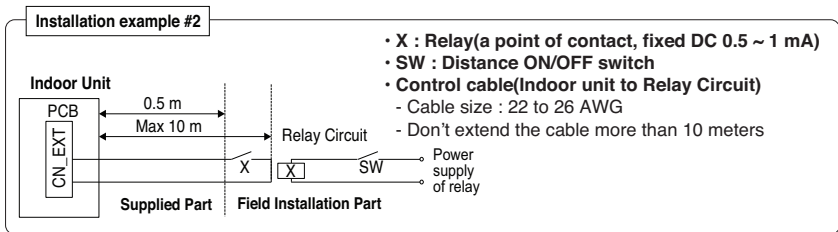
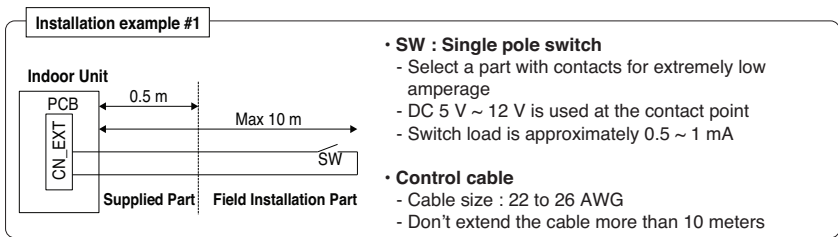
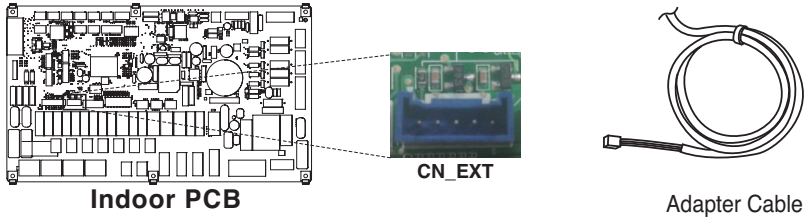

Determining the purpose of CN\_EXT

Setting value: 0 ~ 5 step Indoor CN-EXT port setting

- 0: default
- 1: Simple operation on / off
- 2: Dry contact (simple contact)
- 3: Emergency stop only for indoor unit
- 4: Reattachment / absence
- 5: Emergency stop of all indoor units (It can be set only when indoor unit has emergency stop function)

## External pump

External pump can be required when the room to take floor heating is too large or not well-insulated.(potential free) Also, External pump is installed with buffer tank to retain sufficient capacity.

### How to install external pump

Follow below procedures step 1 ~ step 3.

**Step 1.** Check if the power of the unit is turned off.

**Step 2.** Disassemble front panels and distinguish terminal block in Indoor PCB.

**Step 3.** Connect signal cable to terminal block (TB\_EXT\_PUMP) fully.

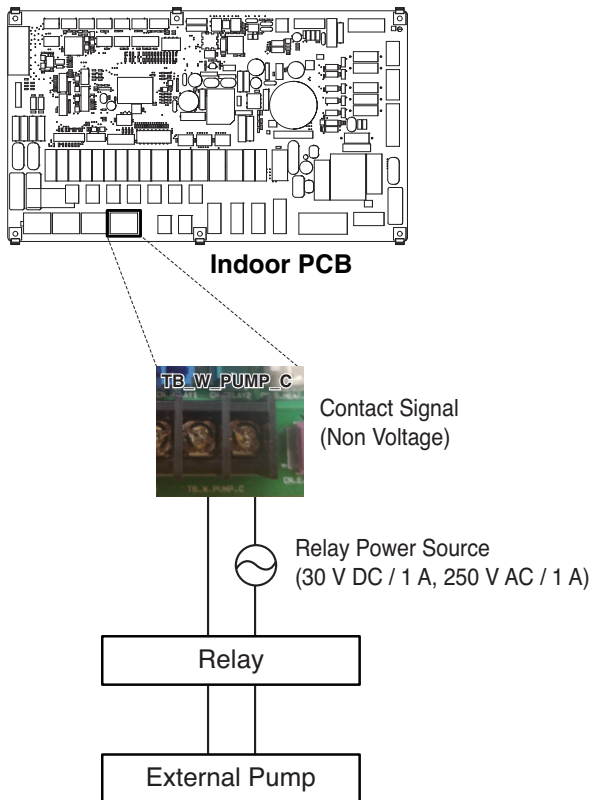

## Wi-fi Modem

Wi-fi modem enables remote system operation from smartphone. Available functions include selection of on/off, operation mode, DHW heating, temperature setup and weekly scheduling etc.

### How to install Wi-fi Modem

[Parts of Wi-fi modem]

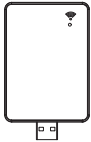

Wi-fi modem body

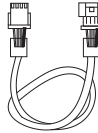

USB Cable

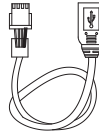

Extension Cable

Follow below procedures step 1 ~ step 5.

**Step 1.** Check if the power of the unit is turned off.

**Step 2.** Disassemble front panels and distinguish control box(Indoor) of the unit.

**Step 3.** Connect the USB cable to the indoor unit PCB (CN\_WF ; Blue) until it clicks into place.

**Step 4.** Connect the Wi-Fi modem to the USB cable fully.

**Step 5.** Refer to the image below to install the Wi-Fi modem in the marked position.

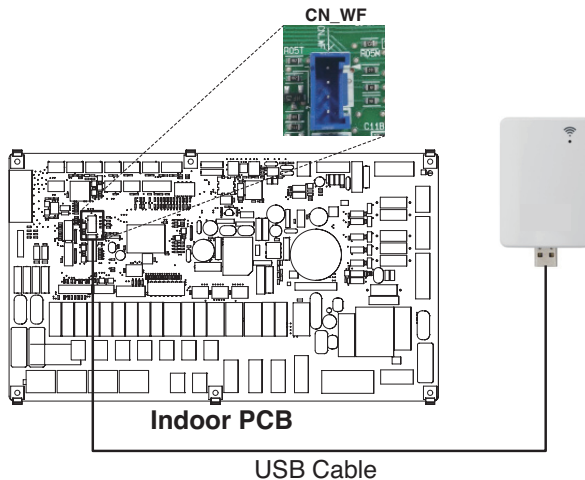

## Smart Grid

This product provides SG Ready function for users. It enables to stop internal operation (Heating / DHW) and control target temperature depending on input signal from power provider.

### How to install smart grid

Follow below procedures step 1 ~ step 3.

**Step 1.** Check if the power of the unit is turned off.

**Step 2.** Disassemble front panels and distinguish terminal block in Indoor PCB.

**Step 3.** Connect signal cable to terminal block in PCB (TB\_SG2, TB\_SG1) fully as shown below.

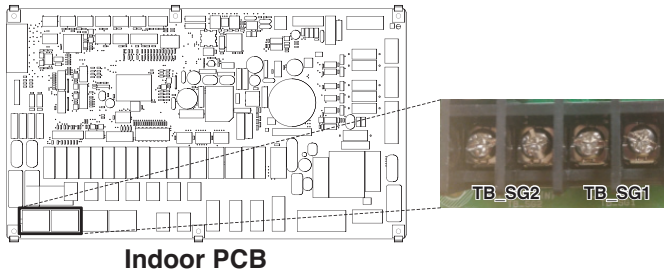

# System Set-Up

As **Hydro Kit** is designed to satisfy various installation environment, it is important to set up system correctly. If not configured correctly, improper operation or degrade of performance can be expected.

## DIP Switch Setting

### ⚠ CAUTION

Turn off electric power supply before setting DIP switch

- Whenever adjusting DIP switch, turn off electric power supply to avoid electric shock.

### General Information

Indoor PCB

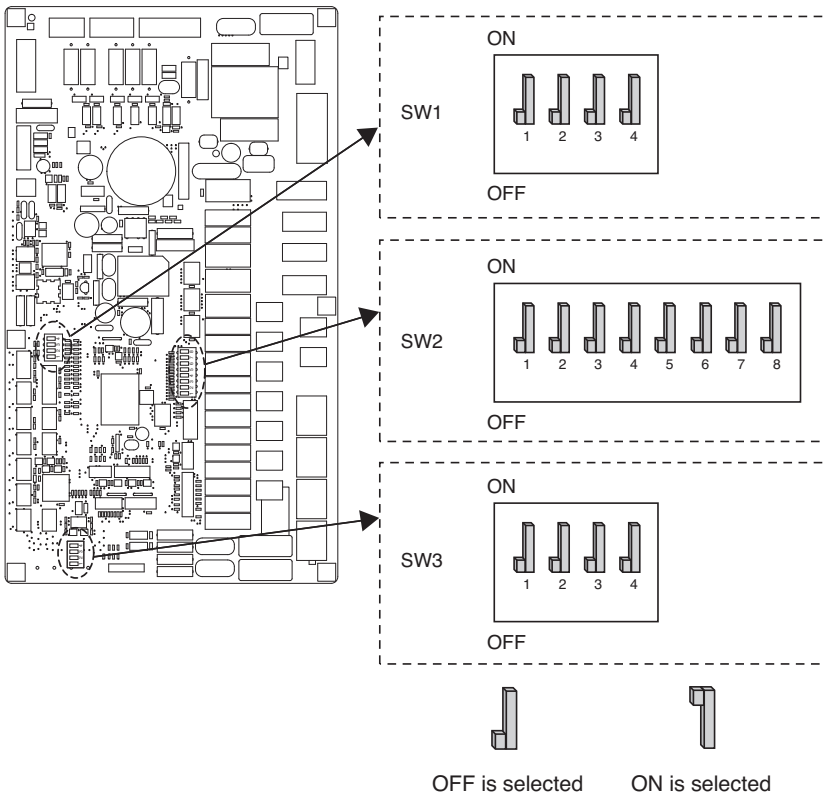

**For Medium Temperature**

## Option Switch 2

x : OFF ● : On

Description	DIP switch setting								Function	Default
	1	2	3	4	5	6	7	8		
Group Control	x								Master	○
	●								Slave	
Installation Scene		x	x						Floor Heating	
		x	●						Floor Heating + Hot Water	○
		●	x						Floor Heating + Hot Water + Solar	
		●	●						Hot Water	
Operation Mode Setting				x					Heating Only	
				●					Heating / Cooling	○
Electric Heater Setup						x	x		Not Use	○
						x	●		Reserved (Don't Select)	
						●	x			
						●	●			
Thermostat Connection								x	Not installed	○
								●	Installed	

**For High Temperature**

## Option Switch 2

x : OFF ● : On

Description	DIP switch setting								Function	Default
	1	2	3	4	5	6	7	8		
Group Control	x								Master	○
	●								Slave	
Installation Scene		x	x						Floor Heating	
		x	●						Floor Heating + Hot Water	○
		●	x						Reserved (Don't select)	
		●	●						Hot Water	
Operation Mode Setting				x					Heating Only	○
				●					Reserved (Don't Select)	
Electric Heater Setup						x	x		Not Use	○
						x	●		Reserved (Don't Select)	
						●	x			
						●	●			
Thermostat Connection								x	Not installed	○
								●	Installed	

**For Medium Temperature**

Option Switch 3

x : OFF ● : On

Description	DIP switch setting				Function	Default
	1	2	3	4		
Sensor Selection	x				Sensor (Air) in Hydro Kit (RS3)	○
	●				Air Sensor (PQRSTA0)	
Antifreeze Operation mode		x			Not Use (connect short key)	○
		●			Use (disconnect short key)	

**For High Temperature**

Option Switch 3

x : OFF ● : On

Description	DIP switch setting				Function	Default
	1	2	3	4		
Sensor Selection	x				Sensor (Air) in Hydro Kit (RS3)	○
	●				Air Sensor (PQRSTA0)	

※ short key

- Medium Temp. : CN\_FLOW2
- High Temp. : Not Available

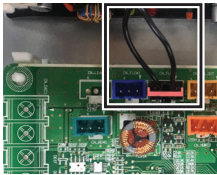

**⚠ CAUTION**

After adding brine(Anti-freeze) only the Water circuit can be set to Anti Freeze mode. Otherwise the product may malfunction due to freezing and bursting.

**⚠ WARNING**

Do not add brine(Anti-freeze) during Hot water mode.

## Group Control Setting

### Group Control

- Wired remote controller 1 + Many of **Hydro Kit**

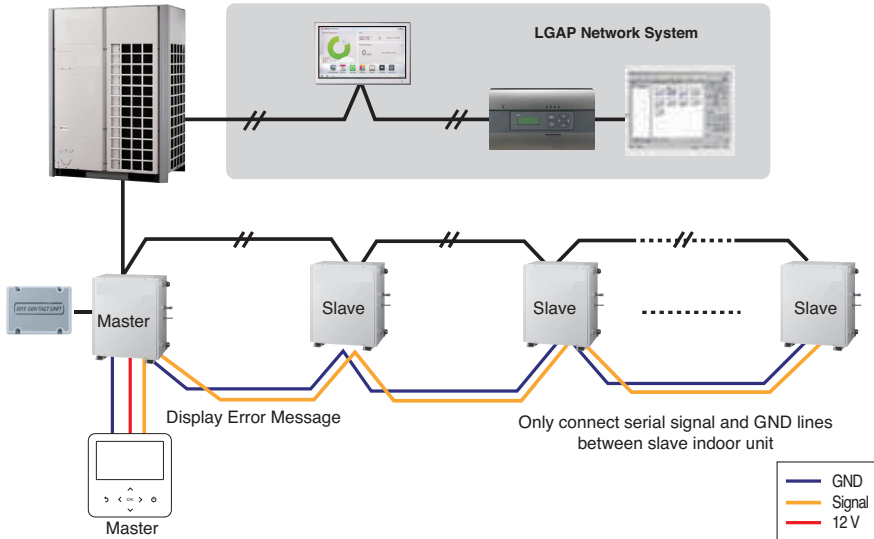

- DIP Switch in PCB

#### ① Master Setting

- No. 1 Off

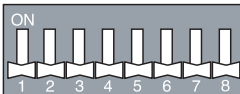

#### ② Slave Setting

- No. 1 On

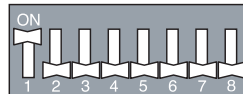

- It is possible to connect 16 indoor units(Max) by one wired remote controller.  
Set only one indoor unit to Master, set the others to Slave.
- It is possible to connect Dry Contact and Central controller at the same time.
  - The Master indoor unit is possible to recognize Dry Contact and Central Controller only.
  - In case of Central controller setting, the Central controller can control indoor units after setting only the address of master indoor unit.
  - Slave indoor unit will be operated like master indoor unit.
  - Slave indoor unit can not be individually controlled by Central controller.
  - Some remote controller can't perform with Dry Contact and Central controller at the same time.  
So contact us further information about it.
- When using hot water mode, it can be operated by connecting temperature sensor to Master PCB only.

## ⚠ CAUTION

- Indoor unit(Hydro Kit)'s group setting is possible which connected same outdoor unit.
  - To install Master and Slave indoor unit, the DIP Switch setting should be same.
  - Group control is not possible between hydro kit and air conditioner.
  - Group control is not possible between mid temperature hydro kit and high temperature hydro kit.
4. In case that the indoor unit has an abnormal problem an error code will be displayed on the wired remote controller.  
With the exception of the indoor unit with the error, you can control each indoor unit individually.
5. In case of Group Control, it is possible to use following functions.
- Selection of operation options (operation/stop/mode/set temperature)
  - It is not possible at some functions.
- \* Master/Slave setting of indoor units be set possible using a PCB DIP Switch.
- \* It can be the cause of malfunctions when there is no setting of master and slave.

## Accessories for group control setting

- Accessories for group control setting

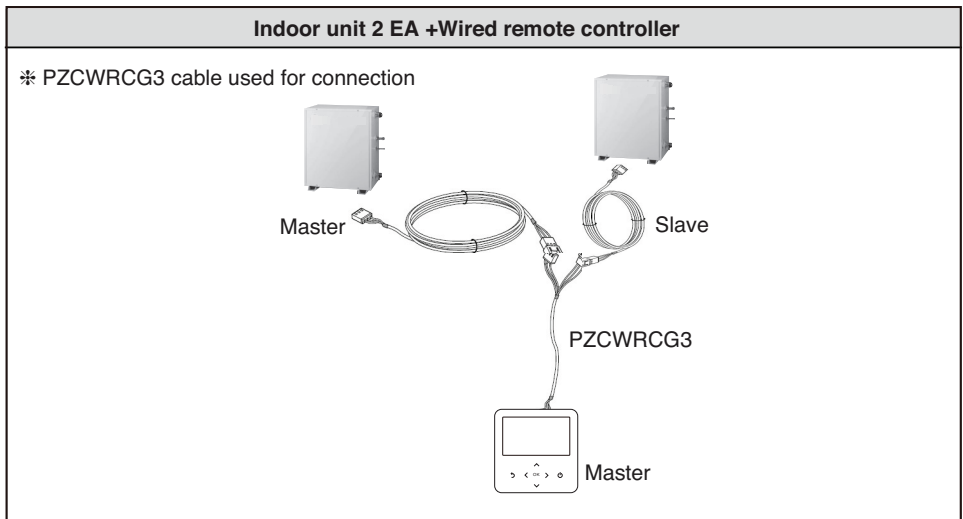

**NOTE****Emergency Operation****• Definition of terms**

- Trouble : a problem which can stop system operation, and can be resumed temporarily under limited operation without certificated professional's assist.
- Error : problem which can stop system operation, and can be resumed ONLY after certificated professional's check.
- Emergency mode : temporary heating operation while system met Trouble.

**• Objective of introducing 'Trouble'**

- Not like airconditioning product, Air-to-Water heat pump is generally operation in whole winter season without any system stopping.
- If system found some problem, which is not critical to system operating for yielding heating energy, the system can temporarily continue in emergency mode operation with end user's decision.

**• Classified Trouble**

- Trouble is classified two levels according to the seriousness of the problem : Slight Trouble and Heavy trouble
- Slight Trouble : a problem is found inside the unit. In most case, this trouble is concerned with sensor problems. The outdoor unit is operating under emergency mode operation condition which is configured by DIP switch No. 4 of the unit PCB.
- Heavy trouble : a problem is found inside the outdoor unit. As the outdoor unit has problem, the emergency mode operation is performed by electric heater located in the unit.
- Option Trouble : a problem is found for option operation such as water tank heating. In this trouble, the troubled option is assumed as if it is not installed at the system.

**• When the AWHP has any trouble,**

- (1) If there is not a function to judge possibility of operation :
  - Once an error occurs mainly in indoor unit, AWHP stops. On the other hand, Remocon allows the product to activate On/ Off operation. (On : emergency operation)
  - Slight / Heavy trouble : Heating Operable only
  - Critical trouble : Full stop
  - Treatment priority : Critical>Heavy>Slight
- (2) If there is a function to judge possibility of operation :
  - Depending on the status of slight / heavy / critical trouble, pop-up phrase is guided separately on display.
  - Slight trouble : Heating/Cooling Operable
  - Heavy trouble : Heating Operable only
  - Critical trouble : Service center request

AWHP operates when user pressed OK button on pop-up window.

- **Duplicated trouble : Option trouble with slight or heavy trouble**

- If option trouble is occurred with slight (or heavy) trouble at the same time, the system puts higher priority to slight (or heavy) trouble and operates as if slight (or heavy) trouble is occurred.
- Therefore, sometimes DHW heating can be impossible in emergency operation mode.  
When DHW is not warming up while emergency operation, please check if DHW sensor and related wiring are all OK.

- **Emergency operation is not automatically restarted after main electricity power is reset.**

- In normal condition, the product operating information is restored and automatically restarted after main electricity power is reset.
- But in emergency operation, automatic re-start is prohibited to protect the product.
- Therefore, user must restart the product after power reset when emergency operation has been running.

## Installer Setting

### How to enter installer setting mode

- In the menu screen, press [**<**, **>**(left/right)] button to select the setting category, and press [**^** (up)] button for 3 seconds to enter the password input screen for the installer setting.
- Input the password and press [**OK**] button to move to the installer setting list.

### ⚠ CAUTION

The installer setting mode is the mode to set the remote controller's detail function. If the installer setting mode is incorrectly set, it may cause product failure, user's injury, or property damage. It must be set by the installation specialist with the installation license, and if it is installed or changed without installation license, all problems caused will be the responsibility of the installer, and may void the LG warranty.

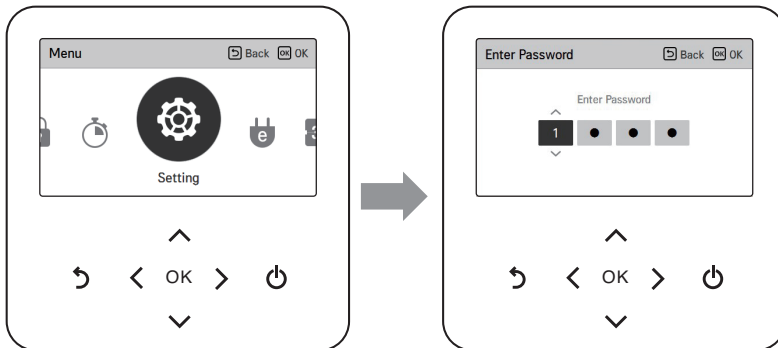

#### \* Installer setting password

Main screen → menu → setting → service → RMC version information → SW Version

Example) SW version : 1.00.1 a

In the above case, the password is 1001.

#### Note:

Some categories of the installer setting menu may not be available depending on the product function or the menu name may be different.

## Summary

- You can set the product user functions.
- Some functions may not be displayed/operated in some product types.

Function text inside remote	Range		Short explanation
	Mid Temp.	High Temp.	
Test Run	Cool test run	N/A	Test run operates Multi V in Cooling mode for max 18 minutes.
3 Minutes delay	N/A		Only for factory testing, cannot change standby timer compressor restart after Thermo-Off
Select Temperature Sensor	Control Standard - Air temperature(Air) - Leaving water temp.(Water) (Default) Sensor Location - Remote control - Indoor Unit		Selecting the reference sensor (Air/Water) for control.
Dry Contact Mode	- Manual - Auto (default)		Selecting the initial state of the product when a dry contact signal is input.
Central Control Address	Hexa-decimal address - 00~FF (default : 00)		When Central Controller is installed, address assigning is set by this function.
Override Master/Slave	- Master - Slave (default)		Override master/slave selection function is to prevent the unit's different mode operation. If the unit is set as the slave, it is blocked to a change of opposite operating mode(cooling/heating).
Pump test run	Test Run		Checking whether water circulation is normal.
Air cooling set temp.	- Upper Limitation 24 °C ~ 30 °C (30 °C default) - Lower Limitation 16 °C ~ 22 °C (18 °C default)	N/A	Adjusting range of 'Setting Air Temperature' in cooling mode
Water cooling set temp.	FCU is not installed - Upper limitation 20 °C ~ 25 °C (24 °C default) - Lower limitation 16 °C ~ 20 °C (16 °C default) FCU is installed - Upper limitation 20 °C ~ 25 °C (24 °C default) - Lower limitation 5 °C ~ 20 °C (5 °C default)	N/A	Adjusting range of 'Setting Leaving Water Temperature' in cooling mode
Air heating set temp.	- Upper Limitation 24 °C ~ 30 °C (30 °C default) - Lower Limitation 16 °C ~ 22 °C (16 °C default)	- Upper Limitation 24 °C ~ 30 °C (30 °C default) - Lower Limitation 16 °C ~ 22 °C (16 °C default)	Adjusting range of 'Setting Air Temperature' in heating mode
Water heating set temp.	- Upper Limitation 35 °C ~ 50 °C (50 °C default) - Lower Limitation 20 °C ~ 34 °C (20 °C default)	- Upper Limitation 50 °C ~ 80 °C (80 °C default) - Lower Limitation 30 °C ~ 46 °C (46 °C default)	Adjusting range of 'Setting Heating Flow Temperature' in heating mode
DHW set temp.	- Upper limitation 50 °C (50 °C default) - Lower limitation 30 °C ~ 40 °C (40 °C default)	- Upper limitation 50 °C ~ 80 °C (80 °C default) - Lower limitation 30 °C ~ 45 °C (45 °C default)	Adjusting range of 'Setting DHW tank Heating Flow Temperature' in domestic hot water tank heating mode.

Function text inside remote	Range		Short explanation
	Mid Temp.	High Temp.	
Cooling / Heating only mode	- Release(Default) - Set Oil recovery option Type 0(Default), 1(Not use)		Setting Cooling / Heating only mode when Multi V Indoor unit is used only cooling mode in summer and Hydro Kit is used only heating in winter.
Water supply off temp. during cooling	- Water stop temperature 16 °C ~ 25 °C (16 °C default) - FCU use/not use (use default)	N/A	When cooling the floor, it is necessary to stop the supply of cold water to prevent bottom dew.
Outdoor temp. for auto mode	- Upper limitation 10 °C ~ 20 °C (15 °C default) - Lower limitation -20 °C ~ 5 °C (-10 °C default)	- Upper limitation 10 °C ~ 20 °C (15 °C default) - Lower limitation -20 °C ~ 5 °C (-10 °C default)	Setting outdoor Min/Max temperature for auto mode.
Indoor air temp. for auto mode	- Upper limitation 20 °C ~ 30 °C (21 °C default) - Lower limitation 16 °C ~ 19 °C (16 °C default)	- Upper limitation 20 °C ~ 30 °C (21 °C default) - Lower limitation 16 °C ~ 19 °C (16 °C default)	Setting indoor Min/Max temperature for auto mode
LWT for auto mode	- Upper limitation 35 °C ~ 50 °C (50 °C default) - Lower limitation 20 °C ~ 34 °C (20 °C default)	- Upper limitation 65 °C ~ 80 °C (80 °C default) - Lower limitation 40 °C ~ 54 °C (50 °C default)	Setting heating flow Min/Max temperature for auto mode
Tank disinfection setting 1	N/A	- Disable(default), Enable	Setting start/maintain time for pasteurisation
	N/A	- Sun. , Mon. , ... , Fri. , Sat. (Default : Fri.)	Setting start/maintain day for pasteurisation
	N/A	- Start Time : 00 ~ 23 (Default : 23)	Setting start/maintain time for pasteurisation
Tank disinfection setting 2	N/A	- 40 °C ~ 80 °C (70 °C Default)	The temperature set point during disinfection operation.
	N/A	- 5 min ~ 60 min (10 min Default)	When the disinfection tank temperature is reached, the BSH continue to operate regarding this timer.
	N/A	- 1~12 hours (1 hour default)	When the disinfection tank temperature is not reached, stop disinfect regarding this timer.
Tank setting1	N/A		Function for AWHP except for Hydro Kit. When it is necessary to change the weight of heating water source in the hot water tank depending on the user's environment. The value for determining the minimum temperature for maintaining the hot water.
	N/A		Function for AWHP except for Hydro Kit. When it is necessary to change the weight of heating water source in the hot water tank depending on the user's environment. Upper temperature limit for outdoor unit.
Tank setting2	N/A		Function for AWHP except for Hydro Kit. Hysteresis value to maintain the desired temperature of hot water.
	- 00 : Perform hot water - 01 : Perform heating floor		Setting heating demand priority.

## System Set-Up

Function text inside remote	Range		Short explanation
	Mid Temp.	High Temp.	
DHW time setting	- Operation Holding Time 5 min ~ 95 min (30 min Default) - Stop Holding Time 0 min ~ 600 min (180 min default)	- Operation Holding Time 5 min ~ 95 min (30 min Default) - Stop Holding Time 0 min ~ 600 min (30 min default)	Set the hot water maintenance / suppression time.
Pump frequency setting (LPM)	- 15 LPM ~ 92 LPM (46 LPM Default)	N/A	Setting for water flow rate in water piping.
TH on/off Variable, heating air	- Type : 0, 1, 2, 3 (Default 0)		The temperature of the heating air can be adjusted according to the field environment preparing for heating claims.
TH on/off Variable, heating water	- Type : 0, 1, 2, 3 (Default 0)		The temperature of the heating water can be adjusted according to the field environment preparing for heating claims.
TH on/off Variable, cooling air	- Type : 0, 1, 2, 3 (Default 0)	N/A	The temperature of the cooling air can be adjusted according to the field environment preparing for cooling claims.
TH on/off Variable, cooling water	- Type : 0, 1, 2, 3 (Default 0)	N/A	The temperature of the cooling water can be adjusted according to the field environment preparing for cooling claims.
TH on/off Variable, DHW	- Type : 0, 1, 2, 3 (Default 0)		It is a function to set the step value to adjust the hot water temperature thermal on / off according to the field environment.
Heating temp. setting	- 00 : Leaving (Default) - 01 : Entering		It is a function to set the water pipe temperature control standard for heating in accordance with the field environment.
Cooling temp. setting	- 00 : Leaving (Default) - 01 : Entering	N/A	It is a function to set the water pipe temperature control standard for cooling in accordance with the field environment.
Pump setting in heating	- Type : Time, Always (Time default) - OFF Time : 1 min ~ 60 min (1 min default) - ON Time : 1 min ~ 60 min (2 min default)		It is a function to set water pump operation / delay time option for heating.
Pump setting in cooling	- Type : Time, Always (Always default) - OFF Time : 1 min ~ 60 min (1min default) - ON Time : 1 min ~ 60 min (2 min default)	N/A	It is a function to set water pump operation / delay time option for cooling.
Forced operation	- Value 1 : ON , OFF (On Default) - Value 2 Forced Period : 20 ~ 180 hr (20 hr Default) - Value 3 Pump Operating Time : 1 ~ 10 min (10 min Default)		It is a function to deactivate the logic that drives the water pump itself.
CN_CC	- D/C (Dry Contact) Automatic (Default) - D/C (Dry Contact) Not installed - D/C (Dry Contact) installed		Function should be set correct depending on optional dry-contact.
Smart Grid (SG)	- Not Use (Default) - Use - Step 0, Step 1 , Step 2 (Mode Selection)		The function to enable / disable the SG Ready function and to set the reference value at the step 2.

Function text inside remote	Range		Short explanation
	Mid Temp.	High Temp.	
Data logging			The error history of the connected indoor unit can be inquired.
Password Initialization			If you forget the user setting password, you can initialize it in the installer settings.
Refrigerant Leak Sensor	- Not Installed (Default) - Installed		The installation of the flare coupling part and the welding part leakage sensor of the indoor unit is set.
IDU Address Verification			Check the result of Auto Addressing of outdoor unit with remote control.
CN_EXT	Not use (default) - Simple Operation - Simple Dry Contact - Single emergency stop - All emergency stop		Depending on DI / DO set by customer using dry contact port of indoor unit Function to set external input and output control.
ODU Function Master	- Master - Slave (Slave default)		Setting of outdoor function Setting function of Master / Slave.
Low Noise Mode Priority	- ODU (ODU default) - RMC		Function to set low noise mode control subject.
ODU cycle priority	- Not use(Default) - Standby - Heat		Function to select hydro kit operation during heat pump's prioritized operation 'Standby': During heating operation, if indoor unit cooling operation is prioritized and requested, Hydro kit is on standby mode. 'Heat': During cooling operation, if hydro kit heating operation is prioritized and requested, hydro kit turns on to heating. In case of connecting with Heat Recovery type of outdoor unit, Heating mode is selected defaultly and it cannot be changed.
Use External Pump	- Not use (Not use default) - Use		Function to set the control of external water pump.
Pump Prerun/Overrun	- Prerun : 1~10 min (1 min default) - Overrun : 1~10min (1 min default)		Function to circulate the heating water with a water pump before heat exchange and set it to reach the appropriate flow rate.
Estimated energy display	- Clear (Clear default) - Set		Wired remote control The function to set whether to display the estimated amount of power calculated by the product on the screen.
Pump operation time			Indicates the operation time of the water pump installed in the indoor unit, and measures the life of the motor.
IDU operation time			The function to display the operating time and to measure the life of the product.

## CAUTION

There is no disinfection function in Medium Temperature Hydro Kit. So, external control equipment should be installed for disinfection function.

## Common Setting

### • Test Run

Test run should be performed when charging the additional refrigerant is required. The unit must be operated in Cooling mode when the refrigerant is being charged. Test run instantly makes the unit operate in Cooling mode for 18 minutes.

**Note:** • If you press any kind of button during this mode, Test Run mode will be finished.

- After the unit operates under Test run mode for 18 minutes, it will be turned off automatically

### • 3 Minutes Delay

Temporarily eliminates the 3-minute delay function of the outdoor unit Comp.

- Factory use only

### • Select Temperature sensor

The product can be operated according to air temperature or leaving water temperature. The selection for setting temperature as air temperature or leaving water temperature is determined.

**Note :** Air temperature as setting temperature is ONLY available when Remote Air Sensor Connection is enabled and Remote Air Sensor Connection is set as Air temperature. After selecting Air Temperature, select Remote control and Indoor Unit.

### • Dry Contact Mode

This function allows the Dry contact-indoor unit operate under Auto Run mode or Manual mode with remote control panel.

For dry contact mode related detail functions, refer to the individual dry contact manual.

#### **What is dry contact?**

It means the contact point signal input when the hotel card key, human body detection sensor, etc. are interfacing with the air conditioner. Added system functionality by using external inputs (dry contacts and wet contacts).

### • Central Control Address

When Central Controller is installed, address assigning is set by this function.

- Setting value: 00 ~ FF (Hex)
  - first digits: Central control group number
  - last digits: Central control indoor unit number

### • Override Master/Slave

Override master/slave selection function is to prevent the unit's different mode operation. If the unit is set as the slave, it blocks a change of opposite operating mode(cooling/heating).

\* To use override master/slave selection function is only possible when units are connected in series to the outdoor unit.

### • Pump test run

The pump test run is the function to test run by operating the water pump. This function can be used for air vents / flow sensors and others.

## Temperature Range Setting

### • Air cooling set temp.

Determine cooling setting temperature range when air temperature is selected as setting temperature.

#### **NOTE**

##### **Only available when remote air temperature sensor is connected.**

- Accessory PQRSTA0 should be installed.
- Also, Remote air sensor connection should be set properly.

### • Water cooling set temp

Determine cooling setting temperature range when leaving water temperature is selected as setting temperature.

#### **NOTE**

##### **Water condensation on the floor**

- While cooling operation, it is very important to keep leaving water temperature higher than 16 °C. Otherwise, dew condensation can be occurred on the floor.
- If floor is in humid environment, do not set leaving water temperature below 18 °C.

#### **NOTE**

##### **Water condensation on the radiator**

- While cooling operation, cold water may not flow to the radiator. If cold water enters to the radiator, dew generation on the surface of the radiator can be occurred.

### • Air heating set temp.

Determine heating setting temperature range when air temperature is selected as setting temperature.

## **⚠ CAUTION**

##### **Only available when remote air temperature sensor is connected.**

- Accessory PQRSTA0 should be installed.
- Also, Remote air sensor connection should be set properly.

### • Water heating set temp

Determine heating setting temperature range when leaving water temperature is selected as setting temperature.

### • DHW set temp.

Determine heating setting temperature range when DHW temperature is selected as setting temperature.

#### **NOTE**

##### **Only available when DHW tank feature is installed.**

- DHW tank and DHW tank kit should be installed.
- DIP switch No. 2 and 3 should be set properly.

• **Cooling / Heating only mode**

Set the Cooling / Heating only mode when Multi V Indoor unit is used only cooling mode in summer and Hydro Kit is used only heating in winter.

**NOTE**

- CH51 error occur when Combination Ratio exceed limitation without setting Cooling / Heating only Mode. Multi V indoor unit can't be operated heating mode and Hydro Kit can't be operated cooling mode when Cooling / Heating only mode is set. It can't be operated with Multi V Indoor unit and Hydro Kit simultaneously when Cooling / Heating only mode is set.

## Temperature Control Parameter Setting

• **Water supply off temp. during cooling**

Determine leaving water temperature when the product is turned off.

This function is used for preventing condensation on the floor in cooling mode.

- Stop temp. : cut-off temperature. Stop temp. is valid when FCU is installed.
- FCU : determines if FCU is installed or not.
- Example : If Stop temp. is set as '16' and FCU is 'Use' and actually FCU is NOT installed in the water loop, the unit stop operation in cooling mode when the leaving water temperature is below 16 °C.
- Example : If Stop temp. is set as '16' and FCU is 'Not use' and actually FCU is installed in the water loop, the Stop temp. is not used and the unit do NOT stop operation in cooling mode when the leaving water temperature is below 16 °C.

**NOTE**

**FCU Installation**

- If FCU is used, related 2way valve should be installed and connected to the indoor unit PCB.
- If FCU is set as 'Not use' but FCU or 2way valve is NOT installed, the unit can do abnormal operation.

### • Tank disinfection setting 1, 2

Disinfection operation is special DHW tank operation mode to kill and to prevent growth of viruses inside the tank.

- Disinfection active : Selecting enable or disable of disinfection operation.
- Start date : Determining the date when the disinfection mode is running.
- Start time : Determining the time when the disinfection mode is running.
- Max temp. : Target temperature of disinfection mode.
- Duration time : Duration of disinfection mode.

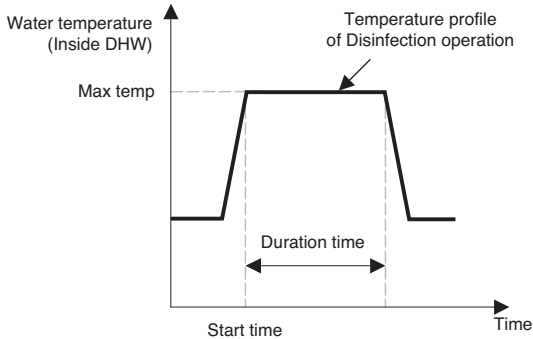

### NOTE

#### DHW heating should be enable

- If Disinfection active is set as 'Not use', that is 'disable disinfection mode', Start date and Start time is not used.
- When Disinfection active is set as 'Use', that is 'enable disinfection mode', Start date is displayed at the position of Disinfection active and Start time is displayed at the position of Start date.

• **Tank setting 1, 2**

Descriptions for each parameters are as following.

- Min temp. : temperature gap from Max outdoor temp.
- Max outdoor temp. : maximum temperature generated by AWP compressor cycle.
- Example : If Min temp. is set as '5' and Max outdoor temp. is set as '48', then Session A (see the graph) will be started when the water tank temperature is below 45 °C.... If temperature is above 48 °C..., then Session B will be started.
- Hysteresis : temperature gap from target DHW temperature. This value is required to frequent On and Off of water tank heater.
- Heating priority : Determining heating demand priority between DHW tank heating and under floor heating.
- Example : If user's target temperature is set as '70' and Hysteresis is set as '3', then the water tank heater will be turned off when the water temperature is above 73 °C. The water tank heater will be turned on when the water temperature is below 70 °C.
- Example : If Heating priority is set as 'DHW', that means heating priority is on DHW heating, DHW is heated by AWP compressor cycle and water heater. In this case the under floor can not be heated while DHW heating. On the other hand, if the Heating priority is set as 'Floor heating', that means heating priority is on under floor heating, DHW tank is ONLY heated by water heater. In this case the under floor heating is not stopped while DHW is heated.

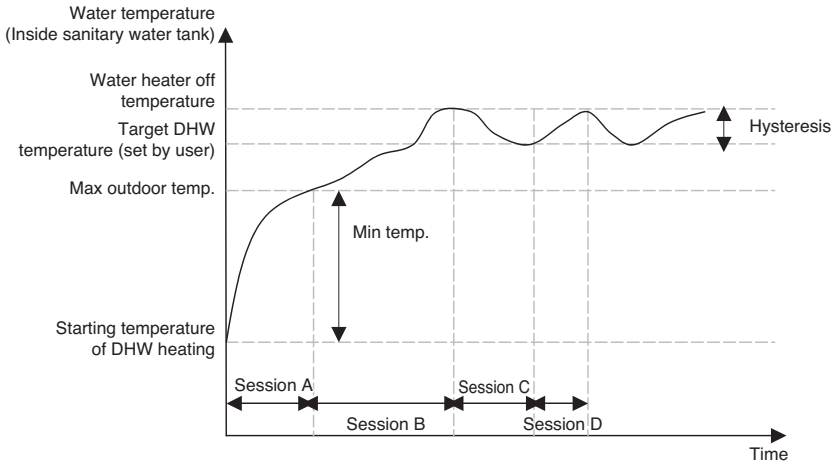

- Session A : Heating by AWP compressor cycle and water heater
- Session B : Heating by water heater
- Session C : No heating (Water heater is Off)
- Session D : Heating by water heater

**NOTE**

**DHW heating does not operate when it is disabled.  
Hydro kit only performs the heating priority function.**

### • DHW time setting

Determine following time duration : operation time of DHW tank heating, stop time of DHW tank heating, and delay time of DHW tank heater operating.

- Active time : This time duration defines how long time DHW tank heating can be continued.
- Stop time : This time duration defines how long time DHW tank heating can be stopped. It is also regarded as time gap between DHW tank heating cycle.

### • TH on/off Variable, heating air

Setting Thermal on/off Air Temperature gap in heating mode

	Th On	Th Off
0	-0.5 °C	1.5 °C
1	-1 °C	2 °C
2	-2 °C	3 °C
3	-3 °C	4 °C

### • TH on/off Variable, heating water

Setting Thermal on/off Water Temperature gap in heating mode

	Th On	Th Off
0	-2 °C	2 °C
1	-3 °C	3 °C
2	-4 °C	4 °C
3	-1 °C	1 °C

### • TH on/off Variable, cooling air

Setting the step value to adjust air temperature gap in cooling mode

	Th On	Th Off
0	0.5 °C	-0.5 °C
1	1 °C	-1 °C
2	2 °C	-2 °C
3	3 °C	-3 °C

### • TH on/off Variable, cooling water

Setting the step value to adjust water temperature gap in cooling mode

	Th On	Th Off
0	0.5 °C	-0.5 °C
1	1 °C	-1 °C
2	2 °C	-2 °C
3	3 °C	-3 °C

• **TH on/off Variable, DHW**

Setting the step value to adjust DHW temperature gap in heating mode

	Th On	Th Off
0	-2 °C	2 °C
1	-6 °C	4 °C
2	-2 °C	4 °C
3	-1 °C	1 °C

• **Heating temp. setting**

At the leaving water control in heating mode, the control reference water temperature position setting.

• **Cooling temp. setting**

At the leaving water control in cooling mode, the control reference water temperature position setting.

• **Pump setting in heating**

It is a function to help the water pump's mechanical life by putting the water pump's rest time. Installer setting function to set water pump operation / delay time option in heating mode.

• **Pump setting in cooling**

It is a function to help the water pump's mechanical life by putting the water pump's rest time. Installer setting function to set water pump operation / delay time option in cooling mode.

• **Forced operation**

If the product is not used for a long time, the product will be forced to operate to prevent pump failure and PHEX freezing.

Water pump off After 20 consecutive hours, disable / enable the logic that drives the water pump by itself.

• **Pump frequency setting (LPM, For Medium Temperature)**

Setting water flow rate

Determine the difference between target inlet water temperature and target outlet water temperature from water flow rate.

Setting value	Water flow rate (l/min)	
	4 HP	10 HP
50	20~22	45~50
55	23~24	51~55
60	25~26	56~60
65	27~28	61~65
70	29~30	66~70
75	31~32	71~75
80	33~34	76~80
85	35~37	81~85
90	38~39	86~90
92	40	91~92

## • CN\_EXT

Determining the purpose of CN\_EXT

Setting value: 0 ~ 5 step Indoor CN-EXT port setting

- 0: default
- 1: Simple operation on / off
- 2: Dry contact (simple contact)
- 3: Emergency stop only for indoor unit
- 4: Reattachment / absence
- 5: Emergency stop of all indoor units (It can be set only when indoor unit has emergency stop function)

## • ODU Function Master

- 1) Setting of outdoor unit function Master status
  - Low noise operation control subject can be set
  - Low noise operation time setting
  - Defrost mode can be set
- 2) Setting of outdoor unit function Slave status
  - No noise operation control subject setting
  - No noise operation time setting
  - No defrost mode setting

## • Low Noise Mode Priority

Setting whether to control in IDU or in ODU

- 1) Setting outdoor management of low noise operation
 

It is controlled by outdoor unit according to switch setting value of low noise operation of outdoor unit PCB.  
Function Setting - Low noise operation time menu is inactivated
- 2) Setting remote control management of low noise operation
 

Low noise operation switch setting of outdoor unit PCB is ignored.  
Function Setting - Low noise operation time menu is activated.

## • ODU cycle priority

Setting ODU Cycle priority as Standby(cooling prioritized during heating) or Heat(heating prioritized during cooling)

- Not use (default)
- Standby: set when IDU's request for cooling operation is the priority during ODU heating.
- Heat: set when Hydro kit's request for heating operation is the priority during ODU cooling (Only apply to Multi V S). This menu is displayed only when ODU function(priority heating) is set.

In case of 'Heat', you have to select one of 5 additional settings values as the table below: Setting value means the holding time needed before turning back to cooling operation once the requested (by the hydro kit) heating operation is turned off.

Setting value	Holding time(minutes)
0	3
1	30
2	60
3	120
4	No limit

### Priority Heating

This is the function that gives priority to the hot water supply operation (heating) for the models that cannot simultaneously operate heating and cooling.

This function enables the appliance to supply hot water and operate indoor cooling by alternately.

# Test Run

## Caution before Operation Test

- Check whether water flow is smoothly supplied.
- Check whether the flow switch properly operates.
- Check whether the connection status is good.
- Check whether the power cable and communication cable are completely connected.
- Check whether it is 2.0 MΩ or above, when insulation resistance between the terminal block and ground is measured with DC mega tester (DC 500 V).
- Never check insulation resistance for the connector of the control board.

## Operation Test of Water Pipe

Category	Status	Check point
Flow Switch Error	CH14	Check whether operation of water pipe is normal.
		Check for the block inside water pipe. (Strainer cleaning, valve locked, valve malfunction, air remaining, etc.)
		Check problem with flow switch. (Flow switch disorder, untold operation, disconnection, etc.)

## Troubleshooting

If **Hydro Kit** operates not properly or it does not start operation, please check following list.

Error No.	Error Type	Main Reasons
01	Air temperature sensor error	Air temperature sensor disconnection or short circuit
02	Gas side temperature sensor error	Gas side temperature sensor disconnection or short circuit
03	No communication between wired remote controller & indoor unit	The remote controller does not receive the signal from indoor unit during specific time
05	Indoor unit & outdoor unit communication error	No signal communication between indoor unit & outdoor unit
06	Liquid side temperature sensor error	Liquid side temperature sensor disconnection or short circuit
08	Water tank temperature sensor error	Water tank temperature sensor disconnection or short circuit
09	Indoor unit EEPROM error	Communication between the micro-processor & the EEPROM / Error due to EEPROM damage
11	Indoor unit & inverter PCB communication error	No signal communication between indoor unit & inverter PCB
12	Inverter PCB error	Error occurrence in inverter PCB
13	Solar thermal temperature sensor error	Solar thermal temperature sensor disconnection or short circuit
14	Flow switch error	Abnormal working of flow switch
15	Water pipe overheated	Water outlet temperature is above 85 °C (185 °F)
16	Water inlet & outlet temperature sensor error	Water inlet & outlet temperature sensor disconnection or short circuit simultaneously
17	Water inlet temperature sensor error	Water inlet temperature sensor disconnection or short circuit
18	Water outlet temperature sensor error	Water outlet temperature sensor disconnection or short circuit
187	Hydro-Kit P.HEX bursting error	Inlet water temperature is below 5 degree or water temperature error during defrosting operation.

## Inverter PCB error ( BC \*\*\* displayed in Remote Controller)

Error No.	Error Type	Main Reasons
21	Inverter compressor IPM defect	Inverter compressor drive IPM defect / inverter compressor defect
22	Inverter compressor overcurrent	Increase of inverter compressor CT value
23	Inverter compressor DC Link low voltage	After inverter activation relay is ON, DC voltage recharge defect
25	High/low Inverter input voltage	Inverter input voltage exceeds the unit limit and lasts for 4 s (173 V ~ 289 V)
26	Inverter compressor activation failure	Inverter compressor error, causing initial activation failure
27	Inverter PSC/PFC Fault Error	Error by overcurrent at inverter input
28	Inverter DC Link high voltage error	Inverter DC voltage recharge, causing compressor OFF
29	Inverter compressor overcurrent	Inverter compressor activation failure or increase of CT value
32	Excessive rise of inverter compressor discharge temperature	Excessive rise of inverter compressor discharge temperature, causing compressor OFF
34	Excessive rise of high pressure of inverter compressor	Excessive rise of high pressure of inverter compressor, causing compressor OFF
35	Excessive drop of low pressure of inverter compressor	Excessive drop of low pressure of inverter compressor, causing compressor OFF
36	Low pressure ratio error of inverter compressor	High pressure/low pressure ratio of inverter compressor is maintained at below 1.8 for 3 min. or more
40	Inverter compressor CT sensor defect	Inverter compressor CT sensor defect
41	Inverter compressor discharge pipe temperature sensor defect	Inverter compressor discharge temperature sensor disconnection or short circuit
42	Low pressure sensor defect of inverter compressor	Low pressure sensor disconnection or short circuit of inverter compressor
43	High pressure sensor defect of inverter compressor	High pressure sensor disconnection or short circuit of inverter compressor
44	Inverter inside air temperature sensor defect	Inverter inside air temperature sensor disconnection or short circuit
46	Inverter compressor suction pipe temperature sensor defect	Inverter compressor suction temperature sensor disconnection or short circuit
53	Communication error(indoor unit → outdoor unit main PCB)	Outdoor unit does not receive signal from indoor unit
60	Inverter PCB EEPROM error	Inverter PCB EEPROM error
62	Excessive rise of inverter heatsink temperature	Inverter PCB heat generation, causing the rise of heatsink temperature
65	Inverter heatsink temperature sensor defect	Inverter heatsink temperature sensor disconnection or short circuit
73	Overcurrent (Peak) detected at inverter input	Error by overcurrent detection (Peak at inverter input

## Airborne Noise Emission

The A-weighted sound pressure emitted by this product is below 70 dB.

- The noise level can vary depending on the site.

The figures quoted are emission level and are not necessarily safe working levels. Whilst there is a correlation between the emission and exposure levels, this cannot be used reliably to determine whether or not further precautions are required. Factor that influence the actual level of exposure of the workforce include the characteristics of the work room and the other sources of noise, i.e. the number of equipment and other adjacent processes and the length of time for which an operator exposed to the noise. Also, the permissible exposure level can vary from country to country. This information, however, will enable the user of the equipment to make a better evaluation of the hazard and risk.

## Model Designation

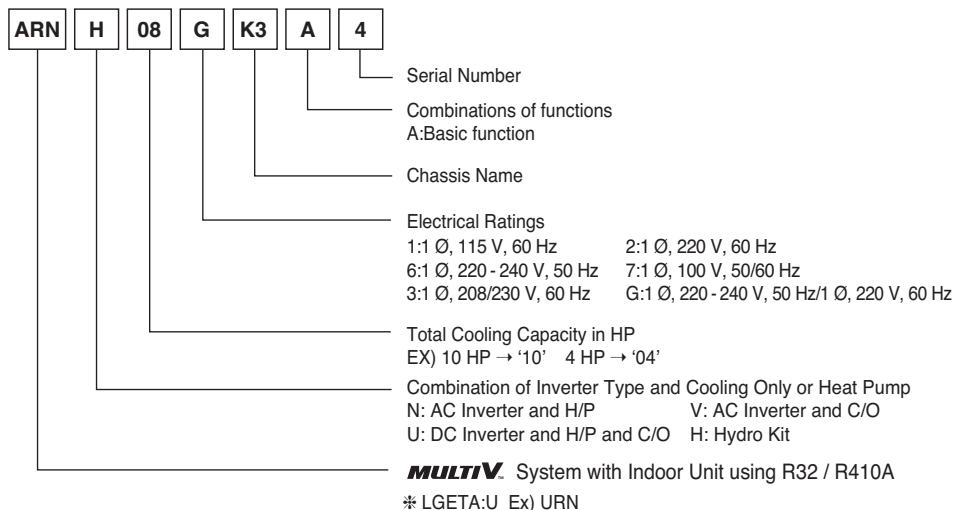





Manufacturer :

LG Electronics Inc. Changwon 2nd factory  
84, Wanam-ro, Seongsan-gu, Changwon-si, Gyeongsangnam-do, KOREA

UK Importer : LG Electronics U.K. Ltd  
Velocity 2, Brooklands Drive, Weybridge, KT13 0SL

**Eco design requirement**

- The information for Eco design is available on the following free access website.  
<https://www.lg.com/global/support/cedoc/cedoc>