

## INSTALLATION MANUAL

# AIR CONDITIONER

Please read this installation manual completely before installing the product.  
Installation work must be performed in accordance with the national wiring standards by authorized personnel only.

Please retain this installation manual for future reference after reading it thoroughly.

Ceiling Concealed Duct



P/NO: MFL67939937

Rev.04\_09092019

[www.lg.com](http://www.lg.com)

Copyright © 2019 LG Electronics Inc. All Rights Reserved

## TIPS FOR SAVING ENERGY

Here are some tips that will help you minimize the power consumption when you use the air conditioner. You can use your air conditioner more efficiently by referring to the instructions below:

- Do not cool excessively indoors. This may be harmful for your health and may consume more electricity.
- Block sunlight with blinds or curtains while you are operating the air conditioner.
- Keep doors or windows closed tightly while you are operating the air conditioner.
- Adjust the direction of the air flow vertically or horizontally to circulate indoor air.
- Speed up the fan to cool or warm indoor air quickly, in a short period of time.
- Open windows regularly for ventilation as the indoor air quality may deteriorate if the air conditioner is used for many hours.
- Clean the air filter once every 2 weeks. Dust and impurities collected in the air filter may block the air flow or weaken the cooling / dehumidifying functions.

### *For your records*

Staple your receipt to this page in case you need it to prove the date of purchase or for warranty purposes. Write the model number and the serial number here:

Model number : \_\_\_\_\_

Serial number : \_\_\_\_\_

You can find them on a label on the side of each unit.

Dealer's name : \_\_\_\_\_

Date of purchase : \_\_\_\_\_

# IMPORTANT SAFETY INSTRUCTIONS

## **READ ALL INSTRUCTIONS BEFORE USING THE APPLIANCE.**

Always comply with the following precautions to avoid dangerous situations and ensure peak performance of your product

### **WARNING**

It can result in serious injury or death when the directions are ignored

### **CAUTION**

It can result in minor injury or product damage when the directions are ignored

### **WARNING**

- Installation or repairs made by unqualified persons can result in hazards to you and others.
- Installation work must be performed in accordance with the National Electric Code by qualified and authorized personnel only.
- The information contained in the manual is intended for use by a qualified service technician familiar with safety procedures and equipped with the proper tools and test instruments.
- Failure to carefully read and follow all instructions in this manual can result in equipment malfunction, property damage, personal injury and/or death.

## Installation

- Always perform grounding.
  - Otherwise, it may cause electrical shock.
- For installation of the product, always contact the service center or a professional installation agency. - Otherwise, it may cause a fire, electrical shock, explosion or injury.
- Securely attach the electrical part cover to the indoor unit and the service panel to the outdoor unit. - If the electrical part cover of the indoor unit and the service panel of the outdoor unit are not attached securely, it could result in a fire or electric shock due to dust, water, etc.
- Always install an earth leakage circuit breaker and a dedicated switching board. - No installation may cause a fire and electrical shock.
- Do not keep or use flammable gases or combustibles near the air conditioner. - Otherwise, it may cause a fire or the failure of product.
- Ensure that an installation frame of the outdoor unit is not damaged due to use for a long time.
  - It may cause injury or an accident.
- Do not disassemble or repair the product randomly. - It will cause a fire or electrical shock.
- Do not install the product at a place that there is concern of falling down. - Otherwise, it may result in personal injury.
- Use caution when unpacking and installing. - Sharp edges may cause injury.
- Use a vacuum pump or Inert (nitrogen) gas when doing leakage test or air purge. Do not compress air or Oxygen and Do not use Flammable gases. Otherwise, it may cause fire or explosion. There is the risk of death, injury, fire or explosion.
- Consult your local dealer regarding what to do in case of refrigerant leakage. When the air conditioner is to be installed in a small room, it is necessary to take proper measures so that the amount of any leaked refrigerant does not exceed the concentration limit in the event of a leakage. Otherwise, this may lead to an accident due to oxygen depletion.
- Carry out the specified installation work after taking into account earthquakes. Failure to do so during installation work may result in the unit falling and causing accidents.

## 4 IMPORTANT SAFETY INSTRUCTIONS

---

- Make sure that a separate power supply circuit is provided for this unit and that all electrical work is carried out by qualified personnel according to local laws and regulations and this installation manual. An insufficient power supply capacity or improper electrical construction may lead to electric shocks or fire.
- Be sure to switch off the unit before touching any electrical parts.
- Make sure that all wiring is secured, the specified wires are used, and that there is no strain on the terminal connections or wires.
- If refrigerant gas leaks during installation, ventilate the area immediately.  
Toxic gas may be produced if the refrigerant gas comes into contact with fire.

### Operation

- Turn off the unit if strange sounds, smell, or smoke comes from it. - Otherwise, it may cause electrical shock or a fire.
- Keep the flames away. - Otherwise, it may cause a fire.
- Do not touch the power cable with wet hands when it taking out . - Otherwise, it may cause a ifre or electrical shock.
- Do not open the suction inlet of the indoor/outdoor unit during operation. - Otherwise, it may electrical shock and failure.
- Do not allow water to run into electrical parts. - Otherwise, it may cause the failure of machine or electrical shock.
- Never touch the metal parts of the unit when removing the filter. - They are sharp and may cause injury.
- Do not step on the indoor/outdoor unit and do not put anything on it. - It may cause an injury through dropping of the unit or falling down.
- When the product is submerged into water, always contact the service center. - Otherwise, it may cause a fire or electrical shock.
- Take care so that children may not step on the outdoor unit. - Otherwise, children may be seriously injured due to falling down.



## CAUTION

### Installation

- Install the drain hose to ensure that drain can be securely done. - Otherwise, it may cause water leakage.
- Install the product so that the noise or hot wind from the outdoor unit may not cause any damage to the neighbors. - Otherwise, it may cause dispute with the neighbors.
- Always inspect gas leakage after the installation and repair of product. - Otherwise, it may cause the failure of product.
- Keep level parallel in installing the product. - Otherwise, it may cause vibration or water leakage.

### Operation

- Avoid excessive cooling and perform ventilation sometimes. - Otherwise, it may do harm to your health.
- Use a soft cloth to clean. Do not use wax, thinner, or a strong detergent. - The appearance of the air conditioner may deteriorate, change color, or develop surface flaws.
- Do not use an appliance for special purposes such as preserving animals vegetables, precision machine, or art articles. - Otherwise, it may damage your properties.
- Do not place obstacles around the flow inlet or outlet. - Otherwise, it may cause the failure of appliance or an accident.
- Do not turn on the breaker or power under condition that front panel, cabinet, top cover, control box cover are removed or opened.

---

# TABLE OF CONTENTS

## 2 TIPS FOR SAVING ENERGY

---

## 3 IMPORTANT SAFETY INSTRUCTIONS

---

## 6 INTRODUCTION

---

6 Features

## 7 INSTALLATION OF INDOOR

---

7 Selection of the best location

7 Installation of Unit

10 Indoor Unit Drain Piping

10 Drain test

11 Thermal insulator

12 Wiring Connection

## 13 INSTALLATION INSTRUCTION

---

16 Remote controller installation

17 Group control

18 Installer Setting - Group Setting

19 Installer Setting - Thermistor

20 Installer Setting - Static Pressure Step  
Setting

21 Installer Setting - Static Pressure  
Setting

22 Installer Setting -E.S.P.

23 Installer Setting -Test Run Mode

27 Installer Setting - Dry Contact Mode  
Setting

## 28 DIP SWITCH SETTING

---

# INTRODUCTION

## Features

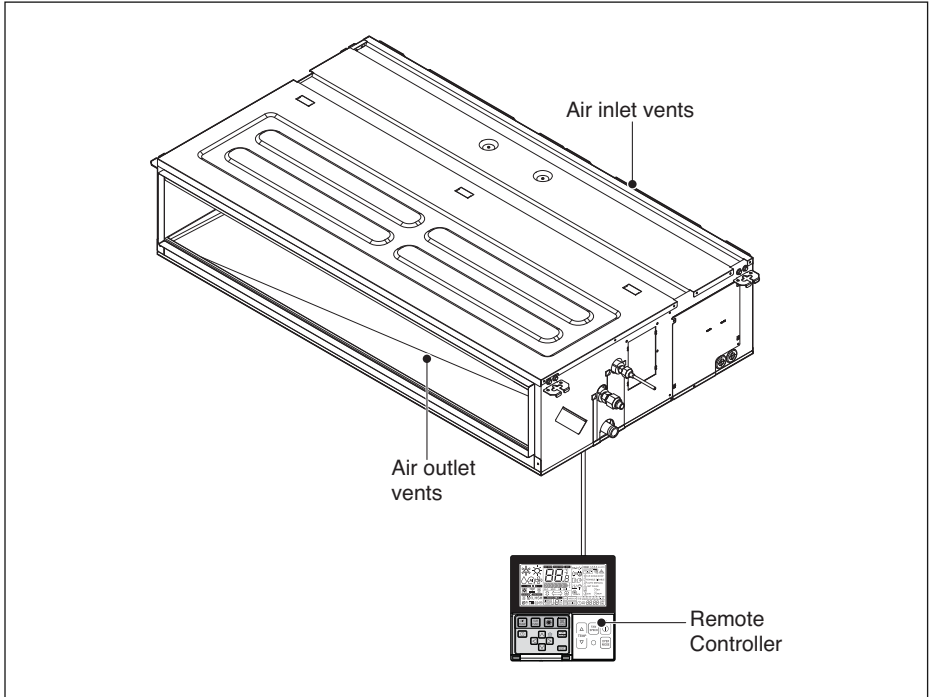

# INSTALLATION OF INDOOR

## Selection of the best location

- The place shall easily bear a load exceeding four times the indoor unit's weight.
- The place shall be able to inspect the unit as the figure.
- The place where the unit shall be leveled.
- The place shall allow easy water drainage.(Suitable dimension "H" is necessary to get a slope to drain as figure.)
- The place shall easily connect with the outdoor unit.
- The place where the unit is not affected by an electrical noise.
- The place where air circulation in the room will be good .
- There should not be any heat source or steam near the unit
- Confirm the positional relationship between the unit and suspension bolts.
- Thermal insulator the ceiling opening to clean the filter or service under the product.

## Installation of Unit

Install the unit above the ceiling correctly.

### CASE 1

#### Position of suspension Bolt

- Apply a joint-canvas between the unit and duct to absorb unnecessary vibration.
- Apply a filter Accessory at air return hole.

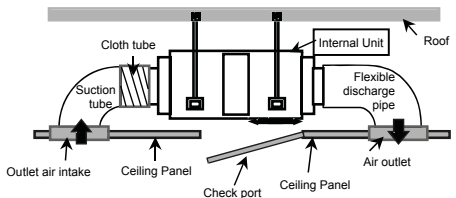
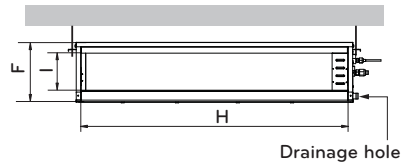
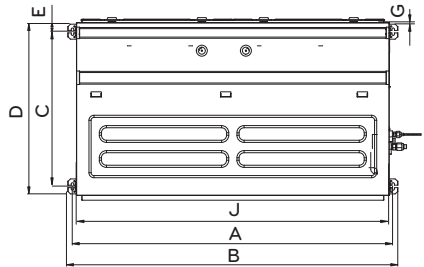

Top view  
Unit: mm

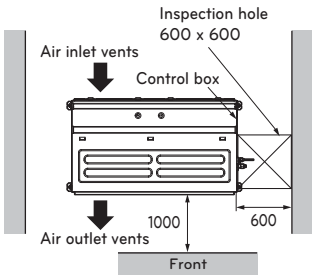

Front view  
Unit: mm

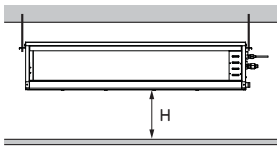

(Unit:mm)

Dimension	A	B	C	D	E	F	G	H	I	J
60k(54k),48k,42k,36k	1283.4	1321.6	619.2	689.6	30	360	15.2	1208	291.4	1250
30k	1283.4	1321.6	619.2	689.6	30	270	15.2	1208	201.4	1250
18k,24k	933.4	971.6	619.2	700	30	270	15.2	858	201.4	900

**CASE 2**

- Install the unit leaning to a drainage hole side as a figure for easy water drainage.

**Position of console Bolt**

- A place where the unit will be leveled and that can support the weight of the unit.
- A place where the unit can withstand its vibration.
- A place where service can be easily performed.

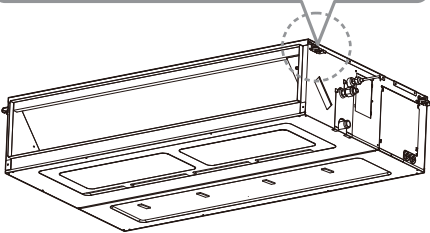
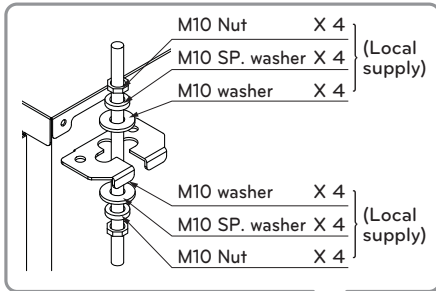
**! CAUTION**

Tighten the nut and bolt to prevent unit falling.

- Select and mark the position for fixing bolts.
- Drill the hole for set anchor on the face of ceiling.

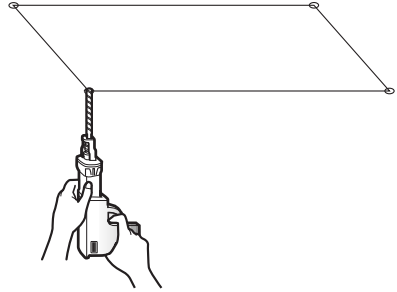

- Insert the set anchor and washer onto the suspension bolts for locking the suspension bolts on the ceiling.
- Mount the suspension bolts to the set anchor firmly.
- Secure the installation plates onto the suspension bolts (adjust level roughly) using nuts, washers and spring washers.

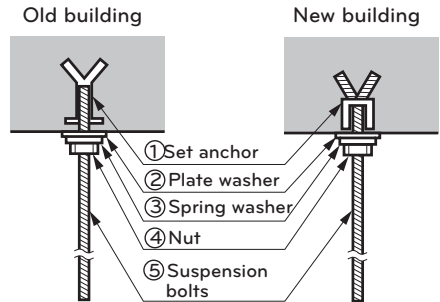

**CAUTION**

- Install declination of the indoor unit is very important for the drain of the duct type air conditioner.
- Minimum thickness of the insulation for the connecting pipe shall be 5mm.

**Front of view**

- The unit must be declined to the drain hose connected when finished installation.

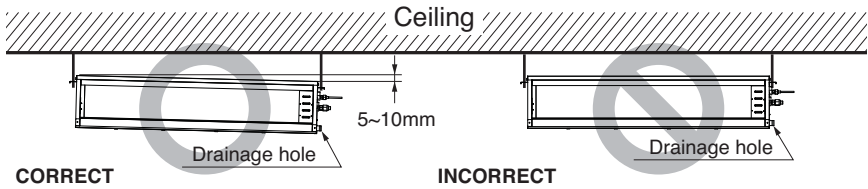

**Caution for gradient of unit and drain piping**

Lay the drain hose with a downward inclination so water will drain out.

- Always lay the drain with downward inclination (1/100 to 1/50). Prevent any upward flow or reverse flow in any part.
- 10 mm or thicker formed thermal insulator shall always be provided for the drain pipe.

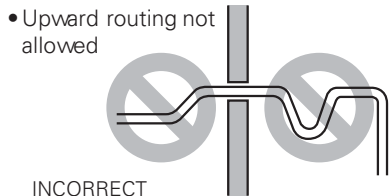
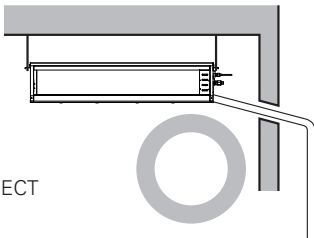
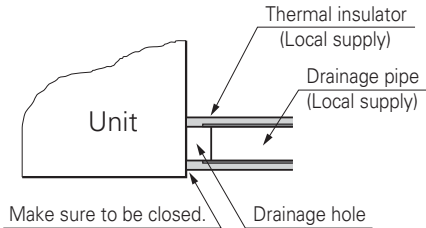

CORRECT

INCORRECT

- Install the P-Trap (or U-Trap) to prevent a water leakage caused by the blocking of intake air filter.

**Applied U-Trap Dimension**

- A 70 mm
- B 2C
- C 2 x SP
- SP = External Pressure (mmAq)
- Ex) External Pressure = 10 mmAq
- A 70 mm
- B 40 mm
- C 20 mm

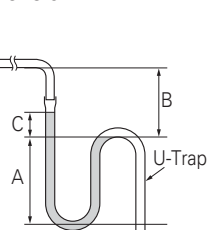

## Indoor Unit Drain Piping

- Drain piping must have down-slope (1/50 to 1/100): be sure not to provide up-and-down slope to prevent reversal flow.
- During drain piping connection, be careful not to exert extra force on the drain port on the indoor unit.
- The outside diameter of the drain connection on the indoor unit is 32 mm.

### Piping material: Polyvinyl chloride pipe VP-25 and pipe fittings

- Be sure to execute thermal insulator on the drain piping.
- Install the drain raising pipes at a right angle to the indoor unit and no more than 300 mm from the unit.

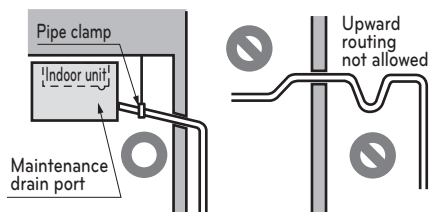

Thermal insulator material: Polyethylene foam with thickness more than 8 mm.

## Drain test

- Connect the main drain pipe to the exterior and leave it provisionally until the test comes to an end.
- Feed water to the flexible drain hose and check the piping for leakage.
- When the test is complete, connect the flexible drain hose to the drain port on the indoor unit.

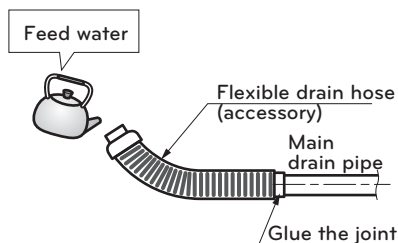

- 1 Remove the air filter.

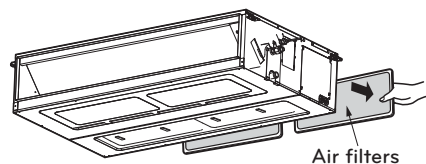

- 2 Check the drain.
  - Spray one or two glasses of water upon the evaporator.
  - Ensure that water flows drain hose of indoor unit without any leakage.

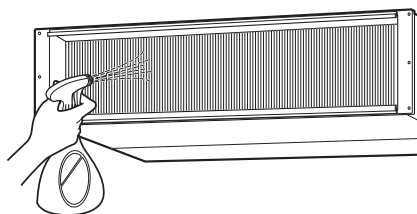

## Piping insulation

- Loosen the flare nut of the indoor unit's piping connection port, insert it into the liquid pipe and the gas pipe, and then conduct flaring work on the ends of each pipe.
- Insulate each of the liquid pipes and gas pipes using insulation material for piping.

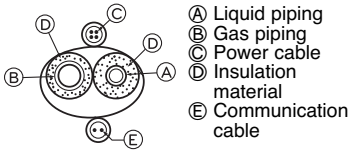

- do the insulation work as it is showing below (piping insulation must be at least 19mm thick)

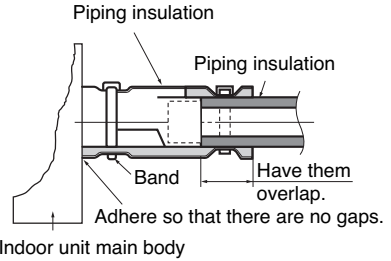
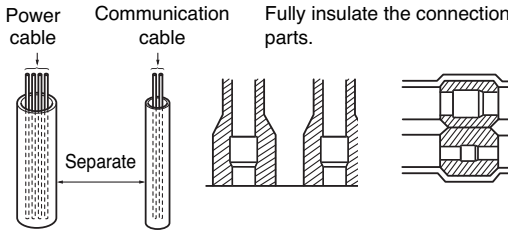

Applies to	Insulation material standard (mm) (besides normal conditions for residential use)		Insulation material Standard (mm) - residential		
			If installed in an air-conditioned place (CASE 1) (ex: bedroom, living room, etc.)	If installed in a non-air-conditioned place (CASE 2) (ex: hallway, outdoors, etc.)	
	Refrigerant piping dimensions (mm)	EPDM	EPDM	EPDM	Insulation material standard (mm) (unfavorable conditions) EPDM
Gas piping	6.35	19	13	19	19
	9.52	19	13	19	25
	12.7	19	13	19	25
	15.88	19	13	19	25
	19.05	19	13	19	25
	22.22	19	13	19	32
	25.40	19	19	19	32
	28.58	19	19	19	32
	31.75	19	19	19	32
	38.1	25	19	25	32
44.45	25	19	25	32	
Liquid piping	6.35	9	9	9	9
	9.52				
	12.7~44.45	13	13	13	13

\* Normal conditions: Temperature of 30 °C, relative humidity of 85 %

\* Unfavorable conditions: Temperature of 30 °C, relative humidity of 90 % (humid places such as bathrooms, swimming pools, etc.: air supply and exhaust fan installation)

## Wiring Connection

- Open the control box cover and connect the Remote controller cable and Indoor power wires.

- Remove the control box cover for electrical connection between the indoor and outdoor unit. (Remove screws ①.)
- Use the cord clamper to fix the cable.

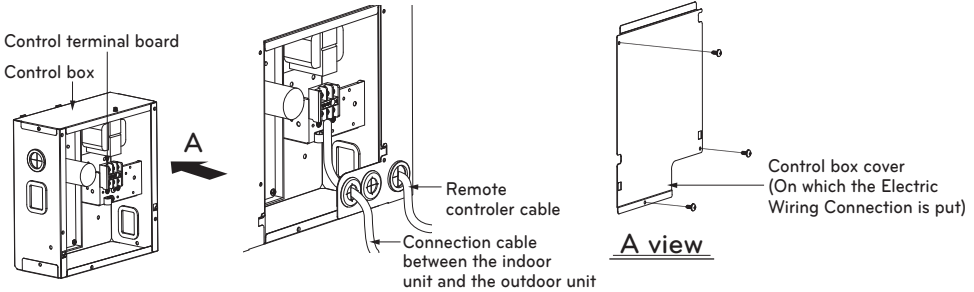

### CAUTION

#### Precautions when laying power wiring

Use round pressure terminals for connections to the power terminal block.

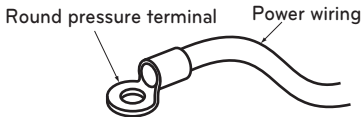

When none are available, follow the instructions below.

- Do not connect wiring of different thicknesses to the power terminal block. (Slack in the power wiring may cause abnormal heat.)
- When connecting wiring which is the same thickness, do as shown in the figure below.

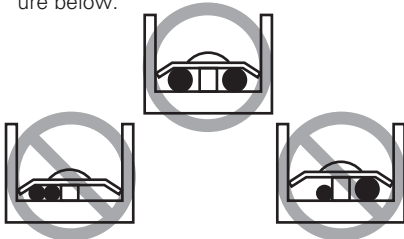

- For wiring, use the designated power wire and connect firmly, then secure to prevent outside pressure being exerted on the terminal block.
- Use an appropriate screwdriver for tightening the terminal screws. A screwdriver with a small head will strip the head and make proper tightening impossible.
- Over-tightening the terminal screws may break them.

### CAUTION

- The connecting cable connected to the indoor and outdoor unit should be complied with the following specifications (Rubber insulation, type H05RN-F approved by HAR or SAA).

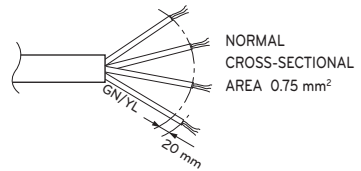

- If the supply cable is damaged, it must be replaced by a special cable or assembly available from the manufacturer of its service agent. When the connection line between the indoor unit and outdoor unit is over 40 m, connect the telecommunication line and power line separately.

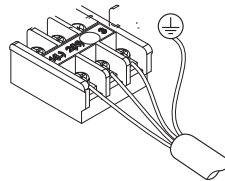

# INSTALLATION INSTRUCTION

- 1 Please fix tightly using provided screw after placing remote controller setup board on the place where you like to setup.
  - Please set it up not to bend because poor setup could take place if setup board bends.

Please set up remote controller board fit to the reclamation box if there is a reclamation box.

- 2 Can set up wired remote controller cable into three directions.
  - Set up direction: the surface of wall reclamation, upper, right
  - If setting up remote controller cable into upper and right side, please set up after removing remote controller cable guide groove.

\* Remove guide groove with long nose.

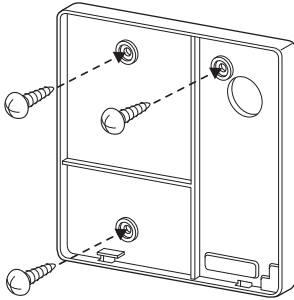

- ① Reclamation to the surface of the wall
- ② Upper part guide groove
- ③ Right part guide groove

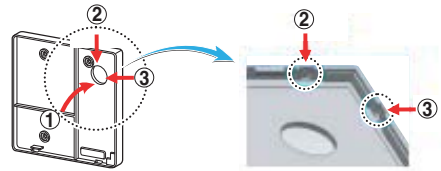

<Wire guide grooves>

- 3 Please fix remote controller upper part into the backplate attached to the surface of the wall, as the picture below, and then, connect with backplate by pressing lower part.
- Please make sure to leave no gaps on the top, bottom, left or right sides between the remote controller and backplate.
  - Before assembly with the backplate, arrange the Cable not to interfere with circuit parts.

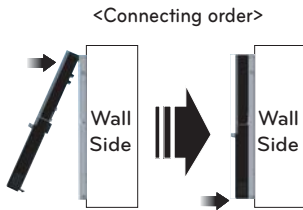

Remove remote controller by inserting a screwdriver into the lower separating holes and twisting to release the controller from backplate.

- There are two separating holes. Please individually separate one at a time.
- Please be careful not to damage the inside components when separating.

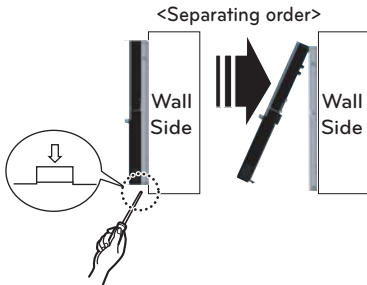

- 4 Please refer to the following directions when connecting the indoor unit and the wired remote controller together.
- Please connect the cables as shown in the figure below when connecting the plug type cable from the indoor unit's C/BOX and the housing type of the extension cable.

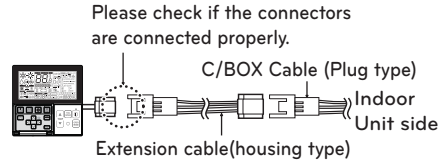

Signal	Yellow
12 V	Red
GND	Black

**CAUTION**

- Specification of LG supplied extension cable: AWG#22, 3 core shielded. (Model : PZCWRC1)
- \* Apply enclosed noncombustible conduit(metal raceway) totally or use FT-6 rated cable or above level in case of local electric & building code that requires plenum (CMP) cable usage.

- When connecting Terminal Blocks of the indoor C/BOX and the wired remote controller with the extension cable, refer to the steps below.

- ① Remove the screw on the cable which is fastened to the wired remote controller's Terminal Block by loosening with a screw driver.
- ② Remove the housing of the provided 32 ft extension cable with a cutting nipper and peel it as shown in the figure below. (when purchasing the extension cable at the site directly, please peel it as shown in the figure below.)

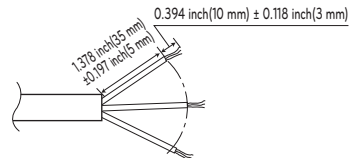

- ③ Make sure each wire is securely fastened under each screw terminal and the wires are not in contact with each other.
- ④ Please connect the Terminal blocks of indoor unit's C/BOX and wired remote controller by referring to the images and contents shown below.  
 Connect the yellow(signal) part of the wired remote controller's terminal block and the 'YL' part of the indoor unit's terminal block.  
 Connect the red(12 V) part of the wired remote controller's terminal block and the 'RD' part of the indoor unit's terminal block.  
 Connect the black(GND) part of the wired remote controller's terminal block and the 'BK' part of the indoor unit's terminal block.

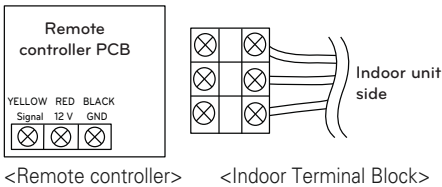

Remote controller PCB Terminal block Remark	Indoor Terminal block	Function
YELLOW	YL	Signal
RED	RD	12 V
BLACK	BK	GND

- \* In case of loosened screws or insufficient contact between the terminal and the wire, remote controller may not function properly.
- \* When the power is off on the remote controller, check the connection between the remote controller and Terminal Block.
- \* Use an appropriate screwdriver for tightening the terminal screws. A screwdriver with a small head will strip the head and make proper tightening impossible.
- \* Over-tightening the terminal screws may break wires and terminal block structure.

**CAUTION**

- Installation work must be performed in accordance with the national wiring standards and local by authorized personnel only.
- Installations must comply with the applicable local/national or international standards.
- AWG#22, 3 core shielded is recommended when using the large hole in the center of the back plate.
- AWG#24, 3 core shielded is recommended when using the side or top knock-out of the back plate.

- 5 Please use an extension cable if the distance between the wired remote controller and the indoor unit is longer than 32 ft(10 m).

**CAUTION**

- When installing the wired remote controller, do not bury it in the wall. (It can cause damage in the temperature sensor.)
- Do not install the cable to be 164 ft(50 m) or longer. (It can cause communication error.)

## Remote controller installation

Since the room temperature sensor is in the remote controller, the remote controller box should be installed in a place away from direct sunlight, high humidity and direct supply of cold air to maintain proper space temperature. Install the remote controller about 5 ft(1.5 m) above the floor in an area with good air circulation at an average temperature.

**Do not install the remote controller where it can be affected by:**

- Drafts, or dead spots behind doors and in corners.
- Hot or cold air from ducts.
- Radiant heat from sun or appliances.
- Concealed pipes and chimneys.
- Uncontrolled areas such as an outside wall behind the remote controller.
- This remote controller is equipped with LCD. display. For proper display of the remote controller LCD's, the remote controller should be installed properly as shown in Fig.1.  
(The standard height is 4~5 ft (1.2~1.5 m) from floor level.)

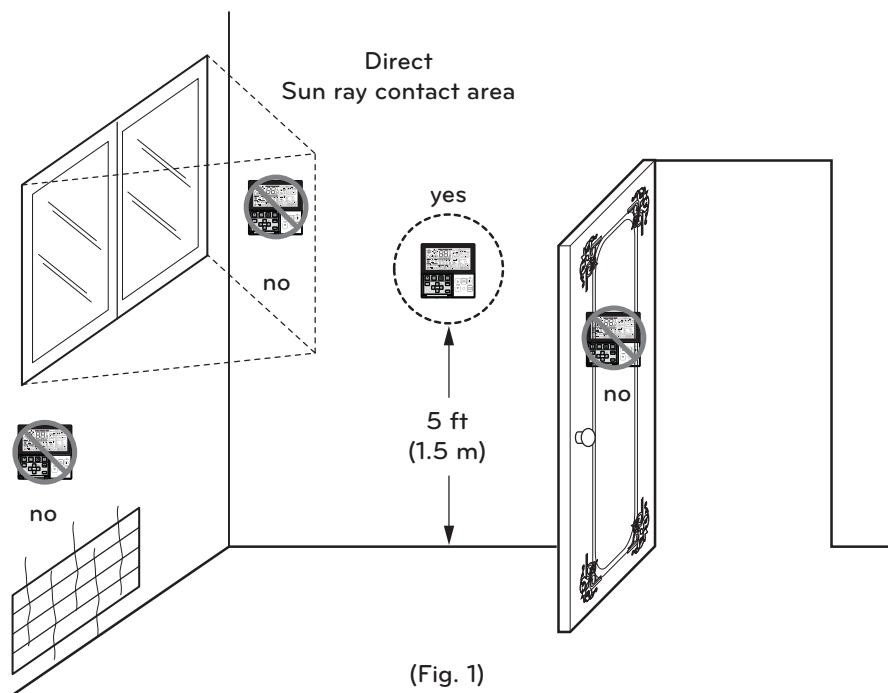

## Group control

- When installing more than 2 units of air conditioner to one wired remote controller, please connect as the right figure.
  - If it is not event communication indoor unit, set the unit as slave.
  - Check for event communication through the product manual.

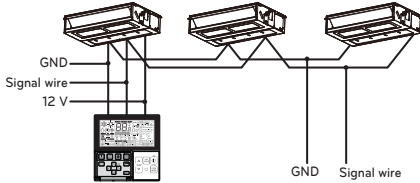

When controlling multiple indoor units with event communication function with one remote controller, you must change the master/slave setting from the indoor unit.

Indoor units, the master/slave configuration of the product after completion of indoor unit power 'OFF' and then 'ON' the power after 1 minutes elapsed sign up.

- For ceiling type cassette and duct product group, change the switch setting of the indoor PCB.



#3 switch OFF: Master  
(Factory default setting)



#3 switch ON: Slave

- For wall-mount type and stand type product, change the master/slave setting with the wireless remote controller. (Refer to wireless remote controller manual for detail)

- \* When installing 2 remote controllers to one indoor unit with event communication function, set the master/slave of the remote controller. (Refer to remote controller master/slave selection)

When controlling the group, some functions excluding basic operation setting, fan level Min/Mid/Max, remote controller lock setting and time setting may be limited.

- When installing more than 2 wired remote controllers to one air conditioner, please connect as the right picture.
  - When installing more than 2 units of wired remote controller to one air conditioner, set one wired remote controller as master and the others all as slaves, as shown in the right picture.
  - You cannot control the group as shown in the right for some products.
  - Refer to the product manual for more detail.

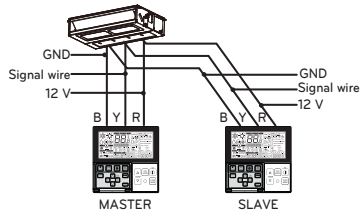

- When controlling in groups, set the master/slaver of the remote controller. Refer to Installer setting section on how to set master/slave for more detail.

## Installer Setting - Group Setting

It is a function for settings in group control, or 2-remote controller control.

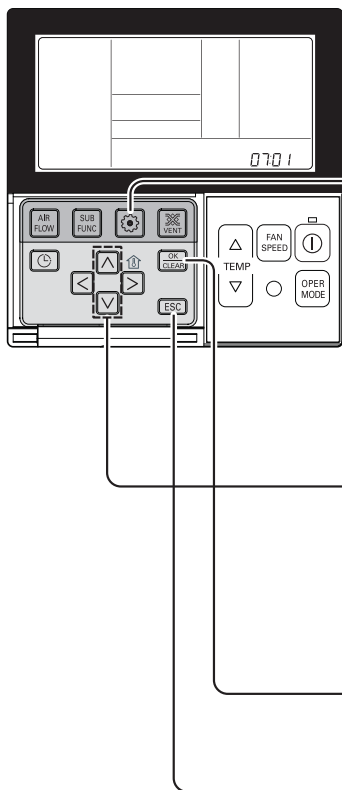



**1** If pressing  button long for 3 seconds, it enters into remote controller setter setup mode.  
- If pressing once shortly, it enters into user setup mode. Please press more than 3 seconds for sure.

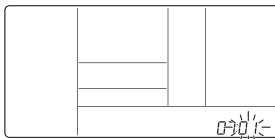

**2** If pressing  button repeatedly, it moves to master/slave selection menu as picture below.



**3** Select Master/ Slave by pressing   button.  
(00: Slave, 01: Master)

  
Function Code      Master/Slave value

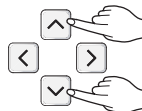

**4** Press  button to save.





**5** Pressing  button will exit settings mode.  
\* After setup, it automatically gets out of setup mode if there is no button input for 25 seconds.  
\* When exiting without pressing set button, the manipulated value is not reflected.

Remote controller	Function
Master	Indoor unit operates based on master remote controller at group control. (Master is set when delivering from the warehouse.)
Slave	Setup all remote controllers except one master remote controller to slave at group control

\* Refer to the 'group control' part for details

### NOTE

When controlling in groups, basic operation settings, airflow strength weak/medium/strong, lock setting of the remote controller, time settings, and other functions may be restricted.

\* Remote controller image may differ upon models accordingly.

## Installer Setting - Thermistor

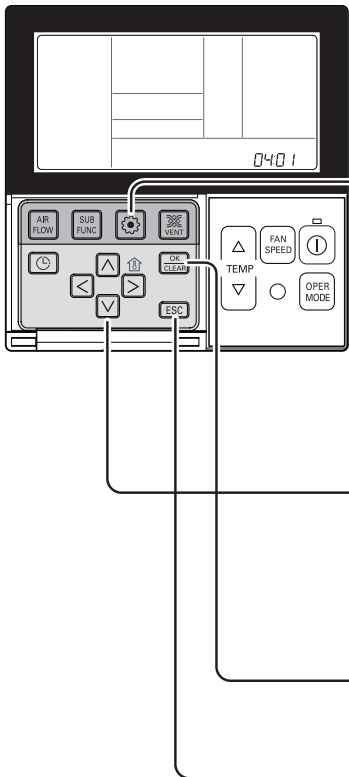

This is the function to select the temperature sensor to judge the room temperature.



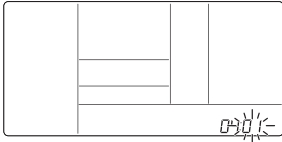

**1** If pressing  button long for 3 seconds, it enters into remote controller setter setup mode.  
- If pressing once shortly, it enters into user setup mode. Please press more than 3 seconds for sure.

**2** If moving to room temperature perception sensor selection menu by pressing  button, it indicates as picture below.



**3** Set Thermistor value by pressing   button. (01: Remote Controller, 02: Indoor, 03: 2TH)



**4** Press  button to save.



**5** Pressing  button will exit settings mode.  
\* After setup, it automatically gets out of setup mode if there is no button input for 25 seconds.  
\* When exiting without pressing set button, the manipulated value is not reflected.

### <Thermistor Table>

Temperature sensor selection		Function
01	Remote controller	Operation in remote controller temperature sensor
02	Indoor unit	Operation in indoor unit temperature sensor
03	2TH	Operation of higher temperature by comparing indoor unit's and wired remote controller's temperature. (There are products that operate at a lower temperature.)
		Operation of lower temperature by comparing indoor unit's and wired remote controller's temperature.

### NOTE

\* The function of 2TH has different operation characteristics according to the product.

\* Remote controller image may differ upon models accordingly.

## Installer Setting - Static Pressure Step Setting

This function is applied to only duct type. Setting this in other cases will cause malfunction.

This function is only available on some products.

This is the function that static pressure of the product is divided in 11 steps for setting.

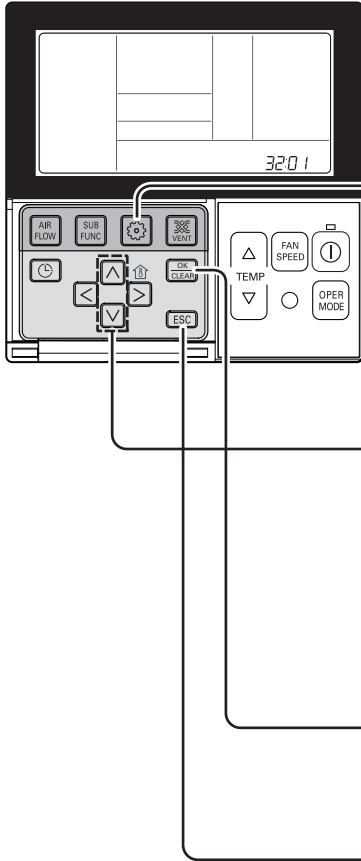

**1** Press button for 4 seconds to enter the installer setting mode until timer segment displays "01:01".



**2** If pressing button repeatedly, it moves to static pressure selection menu as picture below.

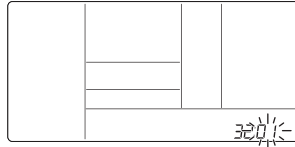

**3** Select static pressure by pressing button.  
00: use static pressure (code 06) set value  
01~ 11: static pressure step (code 32) set value

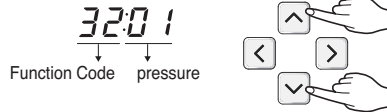

**4** Press button to save.



**5** Pressing button will exit settings mode.  
\* After setup, it automatically gets out of setup mode if there is no button input for 25 seconds.  
\* When exiting without pressing set button, the manipulated value is not reflected.

- Static Pressure (Code 06) setting will not be used if Static Pressure Step (Code 32) setting is being used.

- For the static pressure value for each step, refer to the page 24 Table. 1

### NOTE

\* Remote controller image may differ upon models accordingly.

## Installer Setting - Static Pressure Setting

This function is applied to only duct type. Setting this in other cases will cause malfunction.

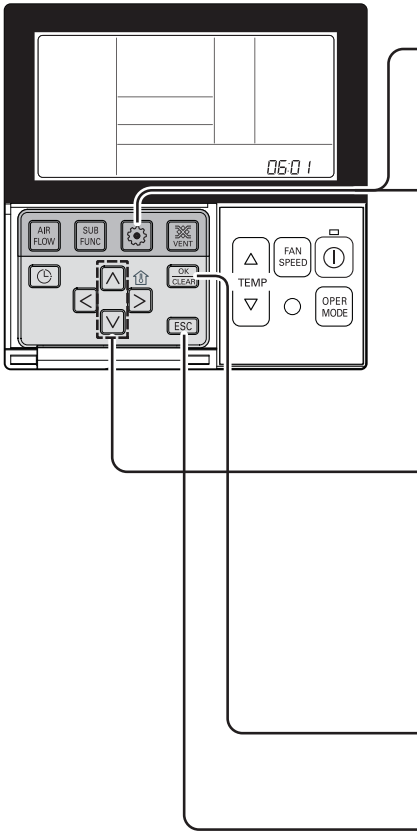

- 1 Press button for 4 seconds to enter the installer setting mode until timer segment displays "01:01".
- 2 If pressing button repeatedly, it moves to static pressure selection menu as picture below.
- 3 Select static pressure by pressing button.  
(01:V-H, 02:F-H, 03:V-L, 04:F-L)
- 4 Press button to save.
- 5 Pressing button will exit settings mode.  
\* After setup, it automatically gets out of setup mode if there is no button input for 25 seconds.  
\* When exiting without pressing set button, the manipulated value is not reflected.

<Static Pressure Setting Table>

Pressure selection		Function	
		Zone state	ESP standard value
01	V-H	Variable	High
02	F-H	Fixed	High
03	V-L	Variable	Low
04	F-L	Fixed	Low

**NOTE**

\* Remote controller image may differ upon models accordingly.

## Installer Setting - E.S.P.

This is the function that decides the strength of the wind for each wind level and because this function is to make the installation easier.

- If you set ESP incorrectly, the air conditioner may malfunction.
- This setting must be carried out by a certificated-technician.

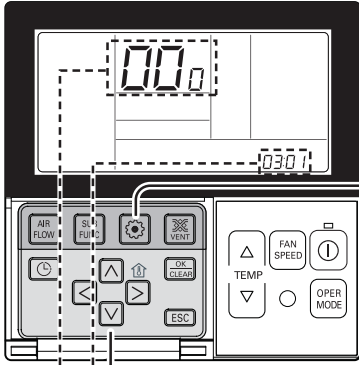

Function code,  
ESP code  
ESP value

- 1 If pressing button long for 3 seconds, it enters into remote controller setter setup mode.  
- If pressing once shortly, it enters into user setup mode. Please press more than 3 seconds for sure.

- 2 If entering into ESP setup mode by using button, it indicates as the picture below.

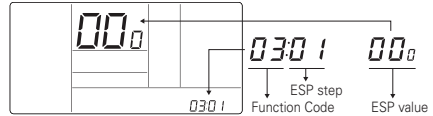

- 3 Select ESP fan step by pressing button. (01: very low, 02: low, 03: medium, 04: high, 05: power)

0301

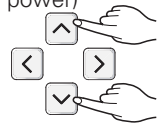

- 4 Move to ESP value setting by pressing button.

(It is 000 when delivering from the warehouse.)

0301 000

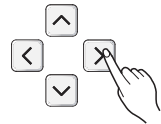

- 5 Press button to setup ESP value.

(It is possible to setup ESP value from 1 to 255, and 1 is the smallest and 255 is the biggest.)

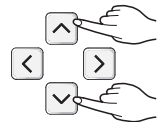

### ! NOTE

When setting ESP value on the product without very weak wind or power wind function, it may not work.

\* Remote controller image may differ upon models accordingly.

## Installer Setting - Test Run Mode

After installing the product, you must run a Test Run mode.

For details related to this operation, refer to the product manual.

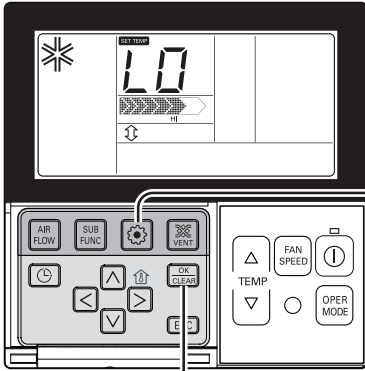

- 1 If pressing  button long for 3 seconds, it enters into remote controller setter setup mode.
  - If pressing once shortly, it enters into user setup mode. Please press more than 3 seconds for sure.
  - Please cancel the right and left of wind direction for RAC product.

0 1 0 1

Function Code      Set

- 2 Setup figure '01' blinks at the lower part of indication window.

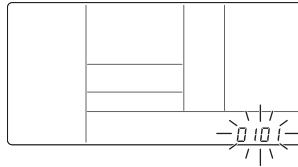

- 3 Press  button to start.

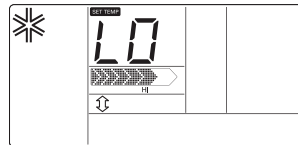

- 4 During the test run, pressing the below button will exit the test run.
  - Select operation, temperature up/down, wind flow control, wind direction, start/stop button.

### NOTE

\* Remote controller image may differ upon models accordingly.

**[Table. 1]**

Capacity - Phase	Step	CMM	Static Pressure[mmAq(Pa)]										
			2.5(25)	4(39)	5(49)	6(59)	8(78)	9(88)	10(98)	11(108)	12(118)	13(127)	14(137)
			Setting Value										
			32 : 01	32 : 02	32 : 03	32 : 04	32 : 05	32 : 06	32 : 07	32 : 08	32 : 09	32 : 10	32 : 11
60k (54k) - 1Φ 60k (54k) - 3Φ	HIGH	50	91	94	97	100	104	109	112	115	117	119	121
	MID	45	86	90	92	96	98	104	106	109	112	114	117
	LOW	40	81	82	89	92	94	100	102	105	108	110	113

Capacity - Phase	Step	CMM	Static Pressure[mmAq(Pa)]									
			4(39)	5(49)	6(59)	7(68)	8(78)	9(88)	10(98)	11(108)	12(118)	
			Setting Value									
			32 : 01	32 : 02	32 : 03	32 : 04	32 : 05	32 : 06	32 : 07	32 : 08	32 : 09	
48k - 1Φ 48k - 3Φ	HIGH	40	83	89	92	94	98	100	102	105	108	
	MID	34	78	82	84	89	94	96	98	101	104	
	LOW	28	74	76	79	82	89	92	94	96	99	

Capacity - Phase	Step	CMM	Static Pressure[mmAq(Pa)]									
			4(39)	5(49)	6(59)	7(68)	8(78)	9(88)	10(98)	11(108)	12(118)	
			Setting Value									
			32 : 01	32 : 02	32 : 03	32 : 04	32 : 05	32 : 06	32 : 07	32 : 08	32 : 09	
42k - 1Φ	HIGH	40	83	89	92	94	98	100	102	105	108	
	MID	34	78	82	84	89	94	96	98	101	104	
	LOW	28	74	76	79	82	89	92	94	96	99	

Capacity - Phase	Step	CMM	Static Pressure[mmAq(Pa)]									
			2(20)	2.5(25)	3(29)	4(39)	5(49)	6(59)	7(69)	8(78)	9(88)	10(98)
			Setting Value									
			32 : 01	32 : 02	32 : 03	32 : 04	32 : 05	32 : 06	32 : 07	32 : 08	32 : 09	32 : 10
36k - 1Φ	HIGH	32	66	69	71	76	80	84	86	89	94	98
	MID	28	62	65	67	72	76	80	82	85	90	94
	LOW	24	58	61	63	68	72	76	78	81	86	90

Capacity - Phase	Step	CMM	Static Pressure[mmAq(Pa)]									
			2(20)	2.5(25)	3(29)	4(39)	5(49)	6(59)	7(69)	8(78)	9(88)	10(98)
			Setting Value									
			32 : 01	32 : 02	32 : 03	32 : 04	32 : 05	32 : 06	32 : 07	32 : 08	32 : 09	32 : 10
30k - 1Φ	HIGH	32	88	90	92	96	100	104	108	112	116	119
	MID	28	80	83	85	90	94	98	103	108	112	115
	LOW	24	74	76	78	82	88	94	99	104	108	111

Capacity - Phase	Step	CMM	Static Pressure[mmAq(Pa)]										
			2(20)	2.5(25)	3(29)	4(39)	6(59)	8(78)	10(98)	12(118)	13(127)	14(137)	15(147)
			Setting Value										
			32:01	32:02	32:03	32:04	32:05	32:06	32:07	32:08	32:09	32:10	32:11
18k - 1Φ	HIGH	16.5	85	87	90	94	103	110	118	125	128	131	134
	MID	14.5	76	77	85	91	97	107	114	121	125	128	131
	LOW	13	73	74	77	88	93	103	111	117	120	125	128
24k - 1Φ	HIGH	18	90	92	95	99	108	115	122	129	132	135	138
	MID	16.5	85	87	90	94	103	111	118	125	128	131	134
	LOW	14.5	76	77	85	89	97	106	114	121	124	127	130

**NOTE**

1. Be sure to set the value referring table 1. Unexpected set value will cause mal-function.
2. Table 1 is based at 230V. According to the fluctuation of voltage, air flow rate varies.
3. Factory Set(External Static Pressure) each Model

Capacity - Phase	Factory set (E.S.P.) mmAq(Pa)	Lower Limit (E.S.P) mmAq(Pa)	Upper Limit (E.S.P) mmAq(Pa)
60k (54k) - 1Φ 60k (54k) - 3Φ	6(59)	2.5(25)	14(137)
48k - 1Φ 48k - 3Φ	6(59)	4(39)	12(118)
42k - 1Φ	6(59)	4(39)	12(118)
36k - 1Φ	8(78)	2(20)	10(98)
30k - 1Φ	8(78)	2(20)	10(98)
24k - 1Φ	6(59)	2(20)	15(147)
18k - 1Φ	6(59)	2(20)	15(147)

**! NOTE**

\* If it is zero static pressure, please set value below Maximum value.

Capacity - Phase	Maximum Value
60k (54k) - 1Φ 60k (54k) - 3Φ	98
48k - 1Φ 48k - 3Φ	98
42k - 1Φ	98
36k - 1Φ	72
30k - 1Φ	98
24k - 1Φ	115
18k - 1Φ	115

## Installer Setting-Dry Contact Mode Setting

Dry contact function is the function that is possible to use only when dry contact equipment is separately purchased/setup.

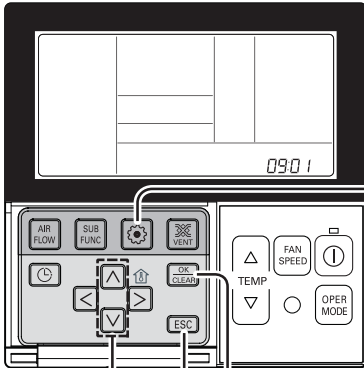

**1** If pressing  button long for 3 seconds, it enters into remote controller setter setup mode.  
- If pressing once shortly, it enters into user setup mode. Please press more than 3 seconds for sure.



**2** If pressing  button repeatedly, it moves to remote controller dry contact mode setup menu as picture below.

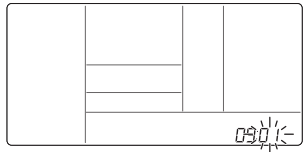

**3** Select Dry contact setting by pressing button.  
(00 : Automatic, 01 : manual)

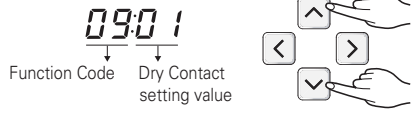

**4** Press  button to save.



**5** Pressing  button will exit settings mode.  
\* After setup, it automatically gets out of setup mode if there is no button input for 25 seconds.  
\* When exiting without pressing set button, the manipulated value is not reflected.

### NOTE

#### What is Dry Contact?

Like hotel card key and body perception sensor, it is the signal of the point of contact when using air-conditioner by interlocking.

- Please refer to dry contact manual for more details.

\* Remote controller image may different upon models accordingly.

# DIP SWITCH SETTING

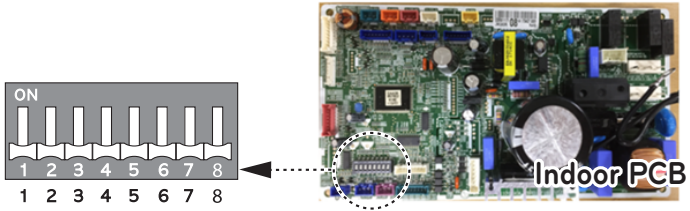

	Function	Description	Setting Off	Setting On	Default
SW3	Group Control	Selection of Master or Slave	Master	Slave	Off
SW4	Dry Contact Mode	Selection of Dry Contact Mode	Wired/Wireless remote controller Selection of Manual or Auto operation Mode	Auto	Off
SW5	Installation	Fan continuous operation	Continuous operation Removal	Working	Off