



# OWNER'S & INSTALLATION MANUAL AIR CONDITIONER

Please read this installation manual completely before installing the product.  
Installation work must be performed in accordance with the national wiring standards by authorized personnel only.  
Please retain this installation manual for future reference after reading it thoroughly.

WIRED REMOTE CONTROLLER  
PREMTW101



MFL69312308  
Rev.02\_041825

ENGLISH

中文

ČEŠTINA

DEUTSCH

EMHÍRKA

ESPAÑOL

FRANÇAIS

ITALIANO

NETERLANDS

POLSKI



[www.lg.com](http://www.lg.com)

Copyright © 2019 - 2025 LG Electronics Inc. All Rights Reserved.

## TIPS FOR SAVING ENERGY

Here are some tips that will help you minimize the power consumption when you use the air conditioner. You can use your air conditioner more efficiently by referring to the instructions below:

- Do not cool excessively indoors. This may consume more electricity.
- Block sunlight with blinds or curtains while you are operating the air conditioner.
- Keep doors or windows closed tightly while you are operating the air conditioner.
- Adjust the direction of the air flow vertically or horizontally to circulate indoor air.
- Speed up the fan to cool or warm indoor air quickly, in a short period of time.
- Clean the air filter once every 2 weeks. Dust and impurities collected in the air filter may block the air flow or reduce the cooling / dehumidifying functions.

### For your records

Staple your receipt to this page in case you need it to prove the date of purchase or for warranty purposes. Write the model number and the serial number here:

Model number : \_\_\_\_\_

Serial number : \_\_\_\_\_

You can find them on a label on the side of each unit.

Dealer's name : \_\_\_\_\_

Date of purchase : \_\_\_\_\_

## SAFETY INSTRUCTIONS

The following safety guidelines are intended to prevent unforeseen risks or damage from unsafe or incorrect operation of the appliance.

The guidelines are separated into 'WARNING' and 'CAUTION' as described below.



This symbol is displayed to indicate matters and operations that can cause risk. Read the part with this symbol carefully and follow the instructions in order to avoid risk.



### WARNING

This indicates that the failure to follow the instructions can cause serious injury or death.



### CAUTION

This indicates that the failure to follow the instructions can cause the minor injury or damage to the product.



## WARNING

### Installation

- For electrical work, contact the dealer, seller, a qualified electrician, or an authorized service Center.
  - Do not disassemble or repair the product. There is risk of fire, electric shock, explosion, equipment malfunction, or injury.
- Request to the service center or installation specialty store when reinstalling the installed product.
  - There is risk of fire, electric shock, explosion, equipment malfunction, or injury.
- Do not disassemble, fix, and modify products randomly.
  - There is risk of fire, electric shock, explosion, equipment malfunction, or injury.
- The product shall be installed according to the national standards and local code.
- Apply totally enclosed noncombustible conduit in case of local building code requiring plenum.
- Use appropriate unit mounting procedures.
- Avoid direct sunlight.
- Avoid moist areas.

### In-Use

- Do not place flammable objects close to the product.
  - There is risk of fire, electric shock, explosion, equipment malfunction or injury.
- Do not allow product to get wet.
  - There is risk of fire, electric shock, explosion, equipment malfunction or injury.
- Avoid dropping the product.
  - There is risk of fire, electric shock, explosion, equipment malfunction or injury.

- If product gets wet, contact your dealer or authorized service center.
  - There is risk of fire, electric shock, explosion, equipment malfunction, or injury. If the instructions are not followed, it may cause death or severe injury of the user.
- Do not use sharp or pointed objects on product.
  - There is risk of fire, electric shock, explosion, equipment malfunction or injury.
- Do not touch or pull the lead wire with wet hands.
  - There is risk of product breakdown or electric shock.

## CAUTION

### In-Use

- Do not clean using powerful detergents like solvent but use soft cloths.  
There is risk of fire, electric shock, explosion, equipment malfunction or deformation.
- Do not press the screen using powerful pressure.  
There is risk of product break-down or malfunction.

## TABLE OF CONTENTS

### 2 TIPS FOR SAVING ENERGY

### 3 SAFETY INSTRUCTIONS

### 8 DESCRIPTION

8 Remote controller

### 9 DESCRIPTION OF THE OPERATION

9 Main screen

9 Menu screen

10 Setting screen

10 Popup screen

11 Monitoring

12 Returning to the screen

### 12 OPERATION SETTING

12 On / Off

12 Operation mode

13 Cooling operation

14 Heating operation

15 AI / Auto operation

### 16 TEMPERATURE SETTING

16 Controlling desired temperature

17 DHW heating operation

17 Quick DHW tank heating

18 View temperature

20 Zone target temperature

### 21 LOCK SETTING

21 How to enter Lock setting

22 Lock setting – all, on/off, mode, DHW lock

### 23 TIMER SETTING

23 Timer entrance and setting method

24 Simple Timer

25 Turn-On Reservation

26 Turn-Off Reservation

### 27 SCHEDULE SETTING

27 How to enter schedule

28 Daily schedule

29 Schedules & Edit

30 Schedules & Edit – Add schedule

31 Exception Day

## 32 INFORMATION OF METER INTERFACE

### 33 FUNCTION SETTING

- 33 How to enter function setting
- 34 Function setting
- 35 Low Noise Mode Time
- 36 Wi-Fi Pairing
- 37 Water Temperature Setting
- 38 3rd Party Boiler

### 39 USER SETTING

- 39 How to enter user setting
- 39 User Setting
- 40 Language
- 41 Temperature Unit
- 42 Screen Saver Timer
- 42 LCD Brightness In Idle
- 43 Date
- 44 Time
- 45 Summer Time
- 46 Password
- 47 Schedule Initialization
- 48 Theme
- 48 System Reboot

### 49 SERVICE SETTING

- 49 How to enter service setting
- 49 Service setting
- 50 Service Contact
- 51 Model Information
- 52 RMC Version Information
- 53 Open Source License

### 54 INSTALLATION

- 54 Installation of Remote Controller
- 56 Group control

### 59 INSTALLER SETTING

- 59 How to enter installer setting
- 60 Installer setting
- 63 Test Run
- 64 3 Minutes Delay
- 65 Select Temperature Sensor
- 66 Dry Contact Mode
- 67 Central Control Address
- 68 Override Master/Slave
- 69 Pump test run
- 70 Air cooling set temp
- 71 Water cooling set temp
- 72 Air heating set temp

- 73 Water heating set temp
- 74 DHW set temp
- 75 Cooling / Heating only mode
- 76 Screed drying
- 78 Heater on temperature
- 80 Water supply off temp. during cooling
- 82 Outdoor temp. for auto mode
- 83 Indoor air temp. for auto mode
- 84 LWT for auto mode
- 85 Tank disinfection setting 1, 2
- 86 Tank setting 1
- 87 Tank setting 2
- 89 Heater priority
- 90 DHW time setting
- 91 Use Heating Tank Heater
- 92 Pump frequency setting (LPM)
- 93 TH on/off Variable, heating air
- 94 TH on/off Variable, heating water
- 95 TH on/off Variable, cooling air
- 96 TH on/off Variable, cooling water
- 97 Heating temp. setting
- 98 Cooling temp. setting
- 99 Pump setting in heating
- 100 Pump setting. in cooling
- 101 Forced operation
- 102 CN\_CC
- 103 Pump Capacity
- 104 Pump frequency setting (RPM)
- 105 Smart Grid(SG)
- 106 Seasonal auto temp
- 108 Modbus Address
- 109 Refrigerant Leak Sensor
- 110 IDU Address Verification
- 111 CN\_EXT
- 112 ODU Function Master
- 113 Low Noise Mode Priority
- 114 Anti-freezing Temperature
- 115 Add Zone
- 116 Use External Pump
- 117 3rd Party Boiler
- 118 Meter Interface
- 119 Estimated energy display
- 120 Pump Prerun/Overrun
- 121 Solar Thermal System
- 123 Zone
- 125 Current flow rate
- 126 Data logging
- 127 Password Initialization
- 128 RMC master/slave

## 129 NOTICE

- 129 OPEN SOURCE SOFTWARE NOTICE INFORMATION

## DESCRIPTION

### Remote controller

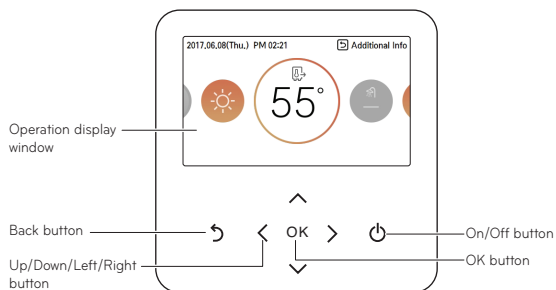

<b>Operation display window</b>	Operation and Settings status display
<b>Back button</b>	When you move to the previous stage from the menu's setting stage
<b>Up/down/left/right button</b>	When you change the menu's setting value
<b>OK button</b>	When you save the menu's setting value
<b>On/Off button</b>	When you turn ON/OFF the air conditioner

#### NOTE

- Some functions may not be operated and displayed depending on the product type.
- The actual product can be different from above contents depending upon model type.
- When using simultaneous operation system, whenever press remote controller button, system will approximately operate after 1~2 minutes.

#### Accessories



Connecting Cable

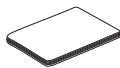

2-Remo cable

Remote controller  
fixing screws  
(4 EA)

Quick Guide

## DESCRIPTION OF THE OPERATION

### Main screen

In the main screen, press [ <, > (left/right) ] button to select the category to set, and you can control by pressing [ ^, v (up/down) ] button.

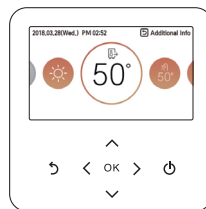

### Menu screen

In the main screen, press [ <, > (left/right) ] button to select the menu and press [OK] button to move to menu screen.

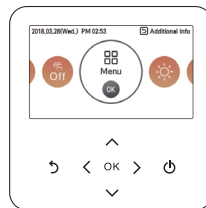

In the menu screen, press [ <, > (left/right) ] button to select the category to set, and press [OK] button to move to the detail screen.

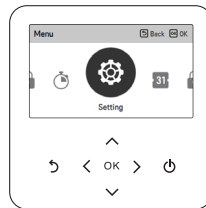

## Setting screen

Select the category to set using [ $\wedge$ ,  $\vee$  (up/down)] button.

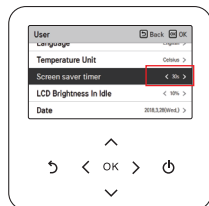

In each detail screen of the menu, as in the box in the left figure, when "<,>" icons are displayed at the same time, you can immediately apply the setting value by pressing [<, >(left/right)] button.

※ For the values that can be set in each category, refer to the detail manual for each function.

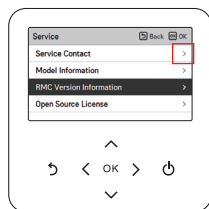

In each detail screen of the menu, as in the box in the left figure, if only ">" icon is displayed, you can move to the detail setting screen by pressing [>(right) or OK] button.

※ For the values that can be set in each category, refer to the detail manual for each function.

## Popup screen

The toast message is the message displayed at the bottom of the screen when an operation is turned On/Off or if a function is set / cancelled.

The popup message is mainly displayed when an error occurred in the product.

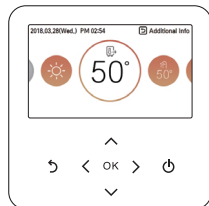

< Toast message >



< Popup message >

## Monitoring

In the main screen, you can enter the monitoring screen by pressing [Back] button. In the monitoring screen, you can check the following information,

- The room temperature
- The water inlet / outlet temperature
- The water pump operation
- The zone status (when set the zone usage via installer setting)

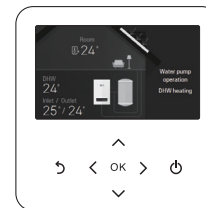
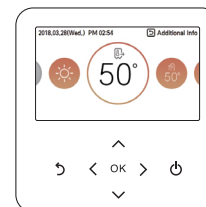

When set the zone usage via installer setting.

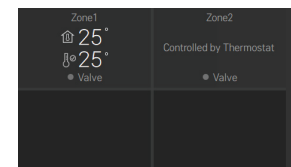
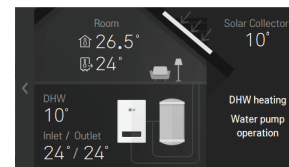

## Returning to the screen

In the main screen, after moving to the category by pressing [<, >(left/right)] button, if there is no remote controller operation, after 10 seconds, it returns to the main screen basic position. (basic position: indoor temperature display part)

In the screens except the main screen, if there is no remote controller operation for 1 minute, it moves to the main screen.

## OPERATION SETTING

### On / Off

**THERMAV.** will be turned on or off.

Press the remote controller's  (On/Off) button.

- If the product is in operation, On/Off button will be illuminated.
- If the product is in off, On/Off button backlight will be off.

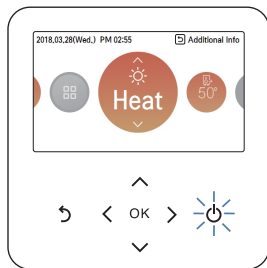

### Operation mode

You can easily control the desired operation mode.

In the main screen, press [<, >(left/right)] button to select the operation mode or home leave or hold category, and press [ $\Delta$ ,  $\nabla$  (up/down)] button to set the operation mode.

※ Some products may not support some operation modes.

Mode	Description
Cool	Cool the room to the desired temperature.
Heat	Heats the room to the desired room temperature.
AI / Auto	The product automatically provides the appropriate fan speed based on the temperature of the room.

## Cooling operation

- Set the desired temperature lower than the water temperature.
- water temperature is displayed on the default screen of the remote controller.
- If the setpoint is set higher than the water temperature, then the unit will remain in the cool mode but will not begin to cool the water temperature exceeds the setpoint.
- If your unit is operating in cooling mode and you press the [On/Off] button the cooling operation will shut off.

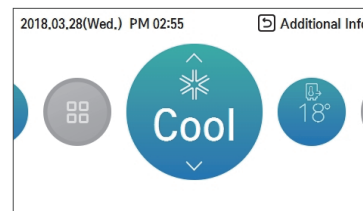

### What is 3 minute delay function?

After the cooling stops, when the product is started right away, the reason that the cold water does not come out is that it is the function to protect the compressor.

The compressor starts after 3 minutes and the cold water comes out.

### NOTE

The compressor starts after 3 minutes and the cold water comes out.

The favorable temperature difference between the water inlet temperature and outlet temperature is 5 °C.

## Heating operation

- Set the desired temperature higher than the water temperature.
- Water temperature is displayed on the default screen of the remote controller.
- When the desired temperature is set lower than the water temperature, warm water doesn't come out.
- If your unit is operating in heating mode and you press the [On/Off] button the heating operation will shut off.

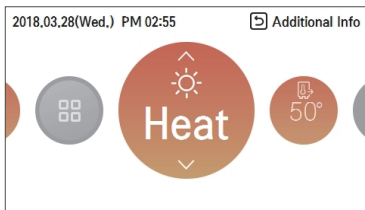

## AI / Auto operation

This mode is only applied to heating.

In order to save energy and to give highest comfort, setting temperature will follow outside temperature. If outdoor temperature decreases, heating capacity for the house will increase automatically in order to keep same room temperature. All parameters will be set by installer during start-up procedure and will be adapted to the site characteristic.

1. Select AI / Auto mode.

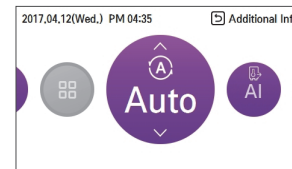

2. Select the desired temperature category

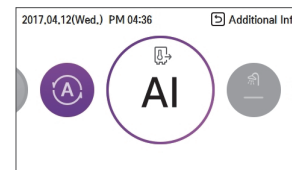

3. Adjust the desired temperature level by press [ $\wedge$ ,  $\vee$ (up/down)] button.

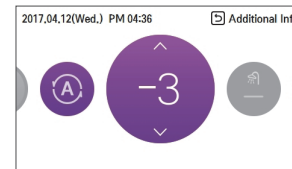

### NOTE

Decreasing temperature profile by 3 °C (based on room air temperature)

<Temperature adjust step (unit : °C)>

-5, -4, -3, -2, -1, 0, 1, 2, 3, 4, 5

← Cold

Hot →

## TEMPERATURE SETTING

### Controlling desired temperature

You can easily control to the desired temperature.

- In the main screen, press [**<**, **>** (left/right)] button to select the desired temperature category, and press [**▲**, **▼** (up/down)] button to set the desired temperature.
- In the cooling, heating, and AI/auto mode, the desired temperature control is possible.

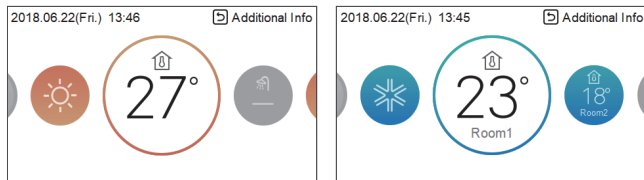

Mode	Description
Room temperature	Room temperature can be set by using remote sensor's internal temperature sensor.
Room 1 & Room 2 temperature	Temperature of Room 1 and Room 2 can be set respectively, when 2nd circuit option is activated in installer mode.
Leaving water temperature	If the desired temperature is lower than the water temperature, the heating is not performed. Set the desired temperature higher than the water temperature.
DHW tank temperature	DHW tank temperature setting is available when DHW tank is installed.
Water inlet temperature	This operation is changed to the temperature sensor only, the inlet temperature sensor, and temperature control logic is the same as the leaving water temperature operation.
Room temperature + Leaving water temperature	Room temperature can be set by using remote sensor's internal temperature sensor. If the desired temperature is lower than the water temperature, the heating is not performed. Set the desired temperature higher than the water temperature.

#### NOTE

The function can be activated according to the installer setting. Refer to the installer setting "Select temperature sensor".

### DHW heating operation

Function to set whether or not to use a installed DHW tank

Press the [**<**] or [**>**] button to focus on the DHW icon, and press the ON / OFF button.

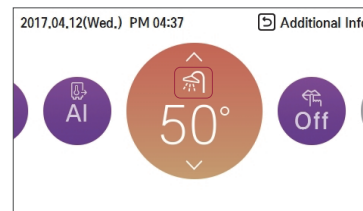

#### NOTE

- This function is not used when the DHW tank is not installed.
- If you want to know more information, refer function on installation information section.

### Quick DHW tank heating

If there is urgent DHW heating demand, Quick DHW Tank Heating mode can be used to reduce the time to reach target DHW tank temperature by forcibly turning on DHW tank heater.

After reaching target DHW tank temperature or by user's input to stop, Quick DHW Tank Heating mode will be finished.

- Press down [Back] button for a second focused on DHW Heating Operation.

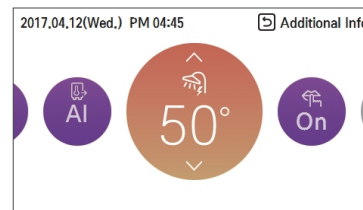

## View temperature

### General mode

You can check the current temperature.

- In the main screen, you can enter the monitoring screen by pressing [Back] button.

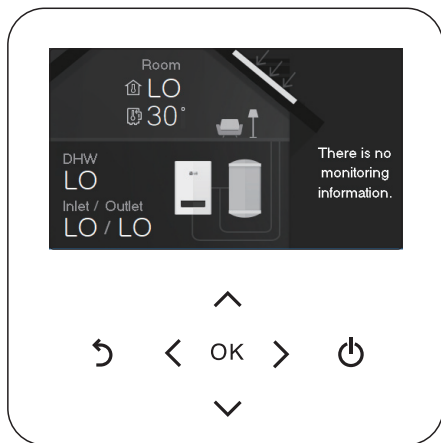

Mode	Description
Room temperature	View room temperature
Inlet temperature	View inlet temperature
Outlet temperature	View outlet temperature
DHW temperature	View DHW temperature (Only displayed when DHW heating mode)
Solar heat temperature	View solar power temperature (Only displayed when DHW water heating mode)

### 2<sup>nd</sup> circuit mode

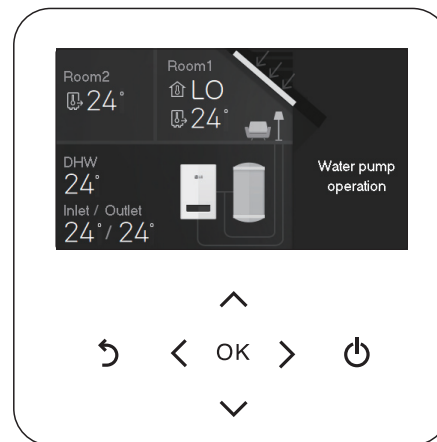

Mode	Description
Room 1 temperature	View room 1 temperature
Room 2 temperature	View room 2 temperature
Inlet temperature	View inlet temperature
Outlet temperature	View outlet temperature
DHW temperature	View DHW temperature (Only displayed when DHW heating mode)
Solar heat temperature	View solar power temperature (Only displayed when DHW water heating mode)

## Zone target temperature

It is the function to set the target temperature for valve control by zone.

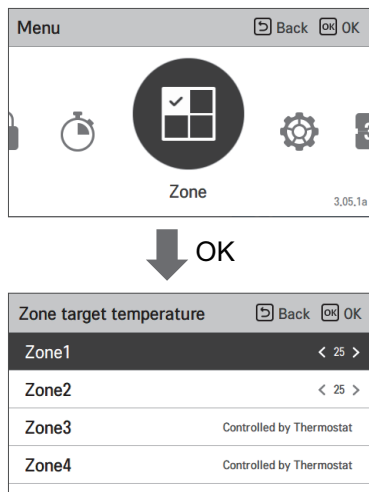

- The number of zones set in the zone setup menu of installer setting is activated.
  - For zone selected by sensor type: Set the target temperature (16 ~ 30 °C) or Open / Close
  - For zones selected by thermostat: Display "Controlled by Thermostat" (Temperature not controllable)

### NOTE

This function is not default.  
It can be activated, after setting value in installer mode.

## LOCK SETTING

### How to enter Lock setting

- In the menu screen, press [←, →] (left/right) button to select "lock setting" category, and press [OK] button to move to the lock setting list screen.
- In the lock setting list, if you press [∧, ∨] (up/down) button, you can turn on/off the corresponding lock function.

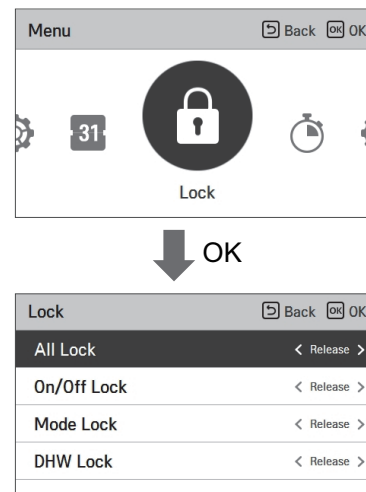

## Lock setting – all, on/off, mode, DHW lock

- It is the function to lock the button operation of the remote controller so that children or other persons cannot use it without permission.
- It is the function to limit the desired temperature range that can be set in the wired remote controller.

Mode	Description
All Lock	It locks all button operation of the remote controller.
On/Off Lock	It locks the On/Off button operation of the remote controller.
Mode Lock	lock It locks the operation mode button operation of the remote controller
DHW Lock	lock It locks the DHW On/Off button operation of the remote controller.

### NOTE

- DHW lock is not used when the DHW tank is not installed.
- If you want to know more information, refer function on installation information section.

### NOTE

In the central controller, when the central control temperature range lock is set, the wired remote controller's temperature lock setting is cleared.  
The temperature change by external equipment is reflected regardless of the remote controller temperature range lock.

## TIMER SETTING

### Timer entrance and setting method

- In the menu screen, press [←,→](left/right) button to select the timer category, and press [OK] button to move to the timer setting list screen.
- In the timer setting list screen, press [↑,↓](up/down) button to select the timer to set, and press [OK] button to move to the detail screen.
- After setting the value, when you press [OK] button, the timer is activated.
- After setting the value, if you press [Back] button, the changed value will not be applied.

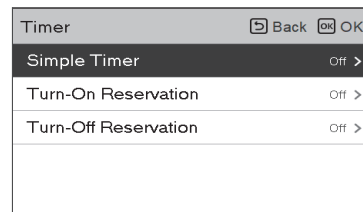
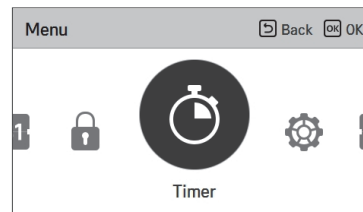

## Simple Timer

You can easily set the timer in the range of 1~7 hours in the units of 1 hour.

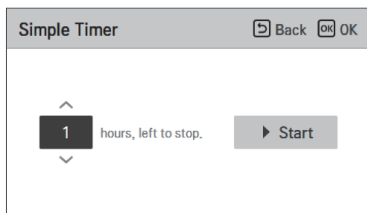
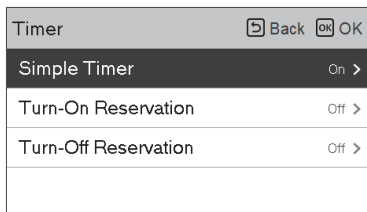

### NOTE

- If the product operation is On, the easy timer turns off the operation after the corresponding time.
- If the product operation is Off, the easy timer turns on the operation after the corresponding time.
- If the easy timer operation is turned On/Off before the timer operation, the set timer will be cleared.

## Turn-On Reservation

The product is automatically turned On at the set timer time.

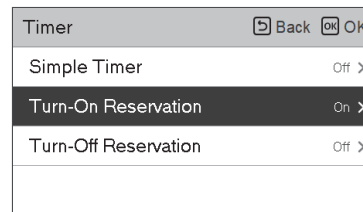

It provides 2 Time formats, 12 Hours(AM/PM) or 24 Hours reference.

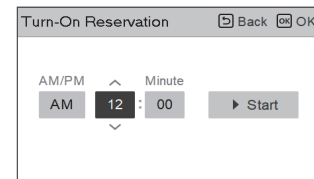
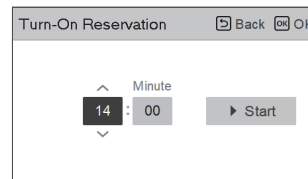

### NOTE

Even if the Turn-on Reservation operation is turned On/Off after the setting and before the timer operation, the set timer is not cleared.

## Turn-Off Reservation

The product is automatically turned Off at the set timer time.

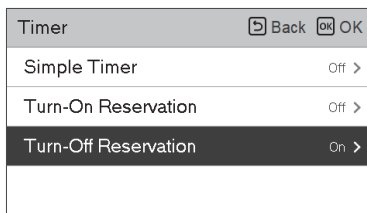

It provides 2 Time formats, 12 Hours(AM/PM) or 24 Hours reference.

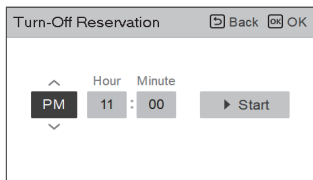
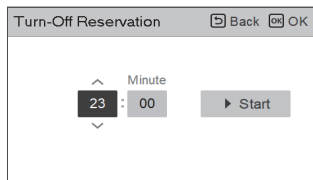

### NOTE

Even if the Turn-off Reservation operation is turned On/Off after the setting and before the timer operation, the set timer is not cleared.

## SCHEDULE SETTING

### How to enter schedule

- In the menu screen, press [←,→(left/right)] button so select the schedule category, and press [OK] button to move to the schedule setting list screen.
- In the schedule setting list screen, press [↑,↓(up/down)] button to select the menu to set, and press [OK] button to move to the detail screen.
- There are 3 options in schedule formula, depending on product function.
  - Room
  - Hot water
  - Heater of hot water tank

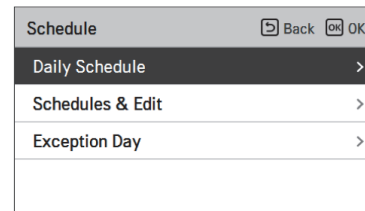
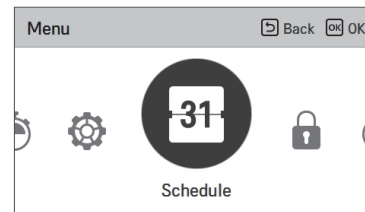

### NOTE

Even though there is a heater of hot water tank schedule option, It cannot be activated in case of sterilization operation.

## Daily schedule

It is the function that can check the status of the timer (schedule) saved in the remote controller.

- In the schedule list, select the daily schedule status category, and press [OK] button to move to the detail daily schedule status screen.
- You can use the remote controller's [←,→(left/right)] button to check the timer information of other dates.

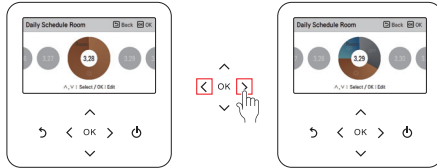

- You can use the remote controller's [∧,∨ (up/down)] button to check the corresponding date's other timer information.

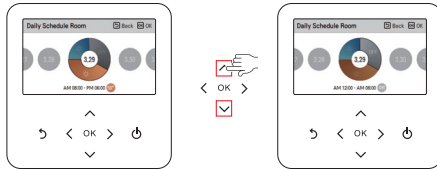

- Select the timer information, and press [OK] button to move to the corresponding timer's edit screen.

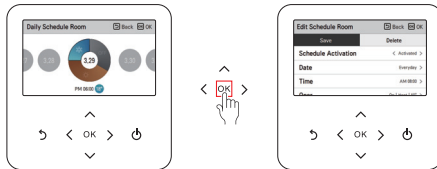

### NOTE

In the daily schedule status screen, even if the timer (schedule) is set, if the corresponding date is designated as an exception date, the schedule will not be performed.  
Less than 5 schedules per day is recommended.

## Schedules & Edit

It is the function that can check the status of the timer (schedule) saved in the remote controller.

- In the schedule list, select the daily schedule status category, and press [OK] button to move to the daily schedule status detail screen.
- You can use the remote controller's [←,→(left/right)] button to check other date's timer information.



You can check the set timer's operation information (operation On/Off, operation mode, desired temperature), timer time, period, and day of week.

- You can edit the saved schedule's timer information.
  - Select the schedule to edit using [∧,∨ (up/down)] button, and press [OK] button to move to the edit screen.

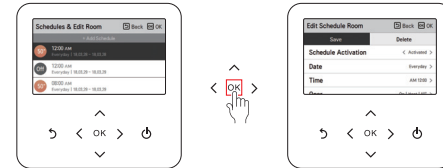

- Select the timer information, and press [OK] button to move to the corresponding timer's edit screen.

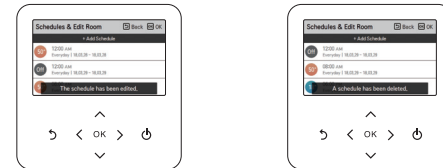

< If schedule is changed >

< If schedule is deleted >

## Schedules & Edit – Add schedule

Description of each stage in Add schedule



Stage 1. Period setting

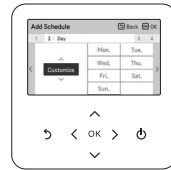

Stage 2. Day of week setting



Stage 3. Time setting



Stage 4. Operation setting



Add schedule is completed

In 'Stage 1', it sets the period to perform the timer.

In 'Stage 2', it sets the day of week to perform the timer.

- You can select 'Everyday / Weekend / Weekdays / Individual selection'.

In 'Stage 3', it sets the start time for the timer.

In 'Stage 4', it sets the timer operation information.

- If 'Stop' is selected, you cannot set the mode / temperature

When stages 1~4 are completed, along with the message of 'schedule is added', it moves to View and edit schedule screen.

## Exception Day

It is the function to automatically stop the operation on the set timer day.

- In the schedule list, select the exception day category, and press [OK] button to move to the Exception day designation detail screen.

- In the exception day, you can check, and add/change/delete the exception day information saved in the remote controller.

- To add an exception day, in the Exception day registration detail screen, designate year/month/day, and press [OK] button to save the Exception day.

- Select the Exception day to edit using [Λ, ∨ (up/down)] button, and press [OK] button to move to the edit screen.

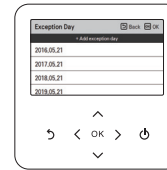

- In the exception day edit screen, you can check, delete/change the corresponding exception day's setting contents.

- When you change the exception day information, you need to save it after the change.

## INFORMATION OF METER INTERFACE

It provides useful information on the amount of energy and power during the week/month/year. Opening "Energy" option, these are presented on screen. You can use this function only when "Meter interface" is activated in installer setting.

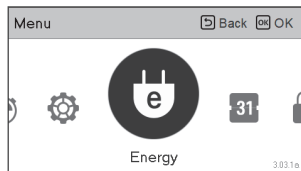

### Instantaneous Power

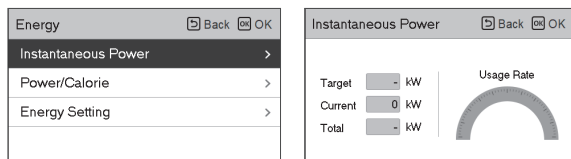

### Power/Calorie

The information includes instantaneous power as well as power/calorie usage and up to annual trend.

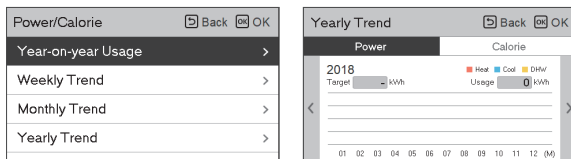

### Energy Setting

In addition, various energy settings are possible as shown below. Current value reaches to defined target value, It alerts to you on display

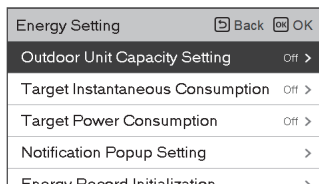

## FUNCTION SETTING

### How to enter function setting

To enter the menu displayed at the bottom, you need to enter the function setting menu as follows.

- In the menu screen, press [←,→] button to select the setting category, and press [OK] button to move to the setting list.
- In the setting list, select the function setting category, and press [OK] button to move to the function setting list.

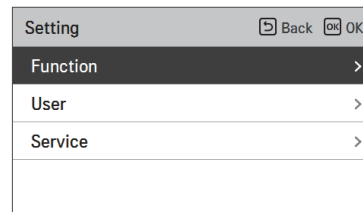
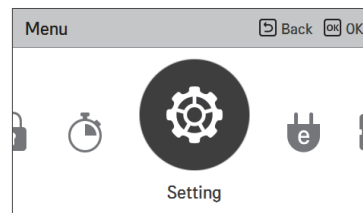

## Function setting

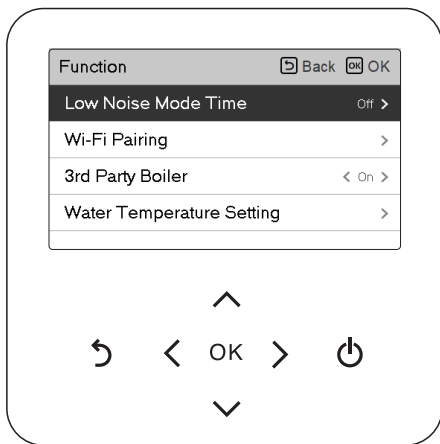

Menu	Description
Low Noise Mode Time	It is the function to set the start and end time of the outdoor unit's low noise mode operation.
Wi-Fi Pairing	It is the function to control remotely through network with indoor unit.
Water Temperature Setting	If you select (Air + Water) as the temperature control mode, This option is activated on screen. It is the function to set target water temperature.
3 <sup>rd</sup> Party Boiler	It is the function to linkage the boiler of other companies. (this function can be activated, after setting every value in installer mode.)

## Low Noise Mode Time

It is the function to set the start and end time of the outdoor unit's low noise mode operation.

- In the function setting list, select the Low Noise Mode Time category, and press [OK] button to move to the detail screen.
  - After setting the start time and the end time, press [OK] button to move to the upper level list.
  - If the start time and the current time are the same, it enters the outdoor unit low noise operation mode, and in the monitoring screen, 'in outdoor unit low noise operation mode' message is displayed.
  - If the end time and the current time are the same, the outdoor unit low noise operation mode is cleared.

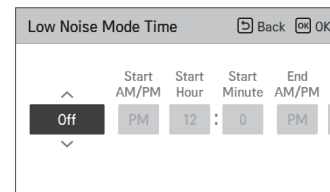
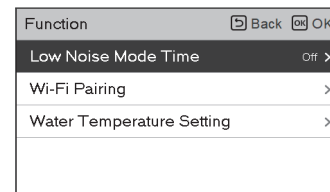

### NOTE

In case that installed with Multi-V, Low noise mode time setting function can be set only when the installer setting's outdoor unit function M/S setting is set to "Master" and low noise mode priority function is set to "RMC".

Low noise mode time setting function is only available in some products.

### CAUTION

If the function is not used, please set it to Off.  
When you enter the low noise operation, the cooling capacity may be degraded.

## Wi-Fi Pairing

It is the function to control remotely through network with indoor unit.

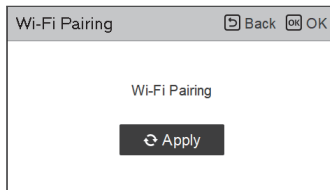
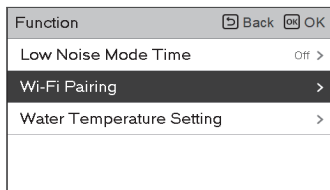

## Water Temperature Setting

### NOTE

This function is not default.  
It can be activated, after setting value in installer mode.

If you choose air+water temperature control way, This option is listed-up on function setting display. It is the function to set target water temperature.

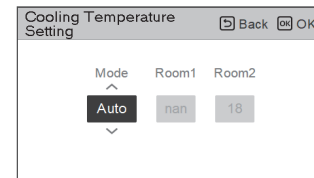
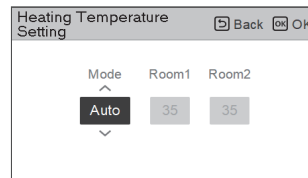
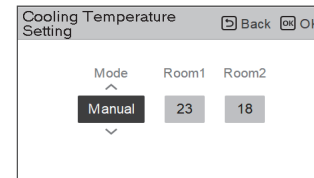
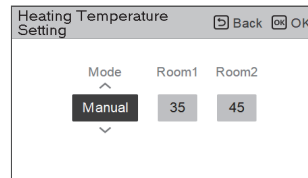
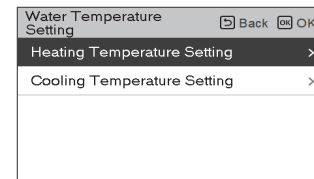
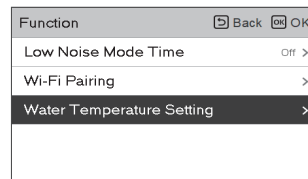

### 3<sup>rd</sup> Party Boiler

#### NOTE

This function is not default.  
It can be activated, after setting value in installer mode.

Function to set whether or not to use an installed 3rd Party function.

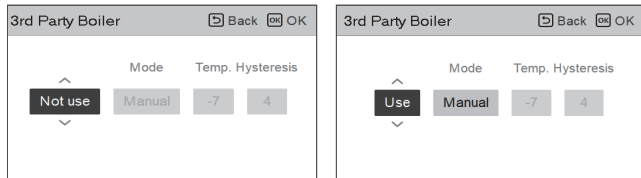

If the mode of this function is set to "Auto", you can set temperature of the boiler and hysteresis, respectively.

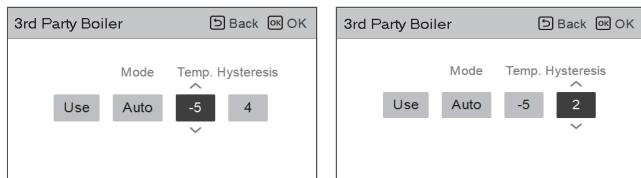

Only when the mode is set to "Manual", 3rd party boiler option is activated in function list.

Function	Back	OK
Low Noise Mode Time	Off	>
Wi-Fi Pairing		>
3rd Party Boiler	< On	>
Water Temperature Setting		>

On/off mode of this option are opened by pushing "<" or ">" button simply and easily.

## USER SETTING

### How to enter user setting

To enter the menu displayed at the bottom, you need to enter the user setting menu as follows.

- Select the setting category, and press [OK] button to move to the setting list.
- Select the user setting category, and press [OK] button to move to the user setting list.

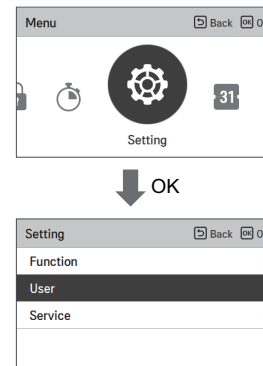

### User Setting

- You can set the product user functions.
- Some functions may not be available in some product types.

Menu	Description
Language	Set the language to be displayed on the remote controller.
Temperature Unit	Set the temperature unit displayed on the remote controller.
Screen Saver Timer	Adjust the screen Off time of the remote controller.
LCD Brightness In Idle	Adjust the remote controller's screen brightness.
Date	Set the date displayed on the remote controller.
Time	Set the time displayed on the remote controller.
Summer Time	Set the summer time in the remote controller.
Password	Set the password to prevent unauthorized change to remote controller settings.
Schedule Initialization	Initialize all timer settings in the remote controller.
Theme	Set the theme of the remote controller screen.
System Reboot	Restart the remote controller.

## Language

Set the language to be displayed on the remote controller.

- In the user setting list, select the language category, and press [OK] button to move to the detail screen.
- After the setting, if you press [OK] button, the setting is saved and moves to the previous screen.

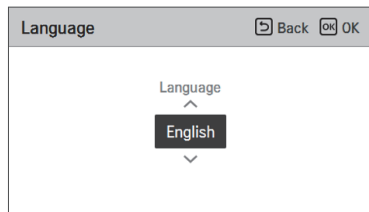
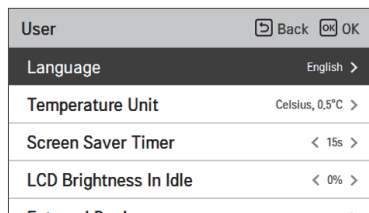

Language			
한국어	English	Français	Italiano
Deutsche	Español	Polski	Čeština
ελληνικά	Nederlands	Românesc	Português
Magyar	Hrvatski	Srpski	Türk
Українська	Български	Slovenščina	中国

## Temperature Unit

Set the temperature unit displayed on the remote controller.

- In the user setting list, select the temperature unit setting category, and press [OK] button to move to the detail screen.

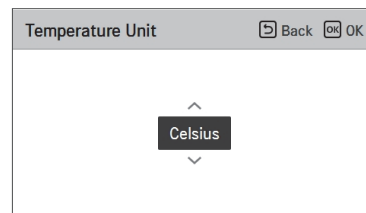
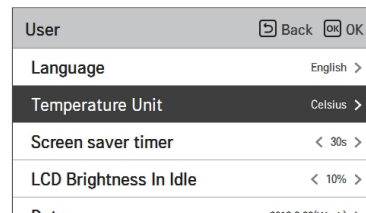

Value	Celsius
	Fahrenheit

### ⚠ CAUTION

The temperature unit function may not work or work differently in some products.  
You cannot set the temperature unit in the slave wired remote controller.

## Screen Saver Timer

Adjust the screen Off time of the remote controller.

- Select the following setting values using [<,>] button.

User	Back OK
Language	English >
Temperature Unit	Celsius, 0.5°C >
Screen Saver Timer	< 15s >
LCD Brightness In Idle	< 0% >
External Device	>

Value		
15 seconds	30 seconds (default)	1 min

### CAUTION

Selecting longer stand by screen will decrease LCD lifespan.

## LCD Brightness In Idle

Adjust the remote controller's screen brightness.

- Select the following setting values using [<,>] button.

User	Back OK
Language	English >
Temperature Unit	Celsius, 0.5°C >
Screen Saver Timer	< 15s >
LCD Brightness In Idle	< 0% >
External Device	>

Value			
0 %	10 % (default)	20 %	30 %

### CAUTION

Selecting brighter stand by screen will decrease LCD lifespan.

## Date

Set the date displayed on the remote controller.

- In the user setting list, select the date category, and press [OK] button to move to the detail screen.
- After the setting, if you press [OK] button, the setting is saved and moves to the previous screen.

User	Back OK
External Device	>
Date	2016.5.18(Wed.) >
Time	PM 02:02 >
Summer Time	Off >
Password	Off >



Date	Back OK
<div style="display: flex; justify-content: space-around; align-items: center;"> <div style="text-align: center;">             ^  <span style="background-color: black; color: white; padding: 2px 5px;">2016</span>              v           </div> <div style="text-align: center;">             Month  <span style="background-color: gray; color: white; padding: 2px 5px;">5</span> </div> <div style="text-align: center;">             Day  <span style="background-color: gray; color: white; padding: 2px 5px;">18</span> </div> </div>	

## Time

Set the time displayed on the remote controller.

- In the user setting list, select the time category, and press [OK] button to move to the detail screen.
- After the setting, if you press [OK] button, the setting is saved and moves to the previous screen.
- In the screen, Time display can be presented in the form of AM / PM or 24 hours standard.

User	
External Device	✓
Date	2016.5.18(Wed.) >
<b>Time</b>	<b>PM 02:04 &gt;</b>
Summer Time	Off >
Password	Off >



Time	
Time Format	Hour Minute
24 Hours	08 : 44

Time	
Time Format	AM/PM Hour Minute
12 Hours	AM 8 : 44

## Summer Time

Set the daylight savings time dates in the remote controller.

- In the user setting list, select the summer time setting category, and press [OK] button to move to the detail screen.
  - Summer time: The system to advance the time by 1 hour from the spring when the day is longer and return back in the fall when the day gets shorter.
  - When it becomes AM 02:00 on the DST start date, the current time changes to AM 03:00, and when it becomes AM 02:00 of the DST end date, the current time changes to AM 01:00.

User	
External Device	✓
Date	2016.5.18(Wed.) >
Time	PM 02:05 >
<b>Summer Time</b>	<b>Off &gt;</b>
Password	Off >



Summer Time	
Off	Month Day - Month Day
	1 1 - 1 1

## Password

Set the password to prevent unauthorized change to remote controller settings.

- Select the user password setting category, and press [OK] button to move to the detail screen.
  - If the password is set, when you enter "menu – setting", you need to input password to enter the setting list.
  - When you forgot the password, you can initialize the password using the installer setting's "password initialization".  
The initialized password is "0000".

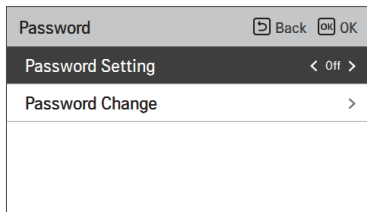
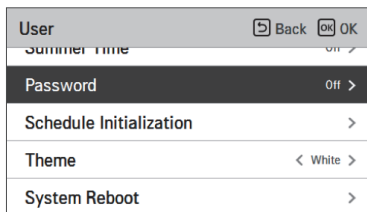

## Schedule Initialization

Initialize all timer settings in the remote controller.

- In the user setting list, select the schedule initialization setting category, and press [OK] button to move to the detail screen.
  - Press the check button to initialize the sleep/simple timer, on/off timer, schedule and exception date in the remote controller.

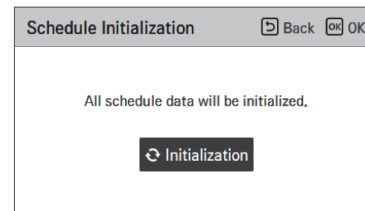
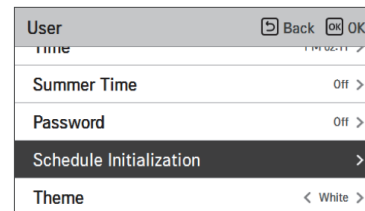

## Theme

Set the theme of the remote controller screen.

- Select either white or black using [←,→] (left/right) button.

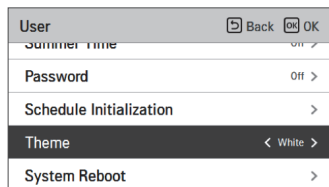

## System Reboot

Restart the remote controller.

- In the user setting list, select the system restart setting category, and press [OK] button to move to the detail screen.
  - In the detail screen, when you press [OK] button, a popup message is displayed, press the check button, to restart the system.
  - For forced reset, press down [On/Off + Back] button for 5 seconds to restart the system.

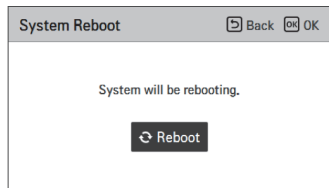
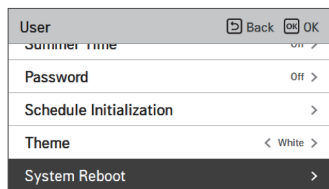

## SERVICE SETTING

### How to enter service setting

To enter the menu displayed at the bottom, you need to enter the service setting menu as follows.

- In the menu screen, press [←,→] (left/right) button to select the setting category, and press [OK] button to move to the setting list.
- In the setting list, select the service setting category, and press [OK] button to move to the service setting list.

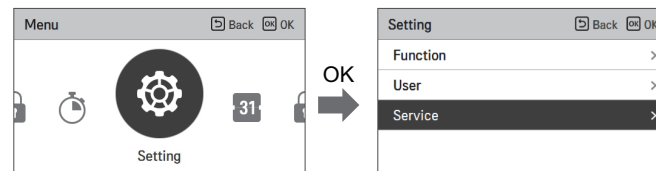

### Service setting

- You can set the product service functions.
- Some functions may not be displayed/operated in some product types.

Menu	Description
Service contact	Check and input the service center phone number that you can call when there is service issue.
Model information	View product and capacity information
RMC Version Information	Check the remote controller model name and software version.
Open Source License	View the remote controller's open source license.

## Service Contact

Check and input the service center phone number that you can call when there is service issue.

- In the service setting list, select the service contact point and press [OK] button to move to the detail screen.
- While "edit" button is selected, press [OK] button to move to the edit screen, change it, and press [OK] button to change the service contact point.

Service	Back	OK
Service Contact	>	
Model Information	>	
RMC Version Information	>	
Open Source License	>	



Service Contact	Back	OK
Telephone		
+1544-7777		
Edit		



Service Contact	Back	OK
Telephone		
+ 1 5 4 4 - 7 7		
7 7		

## Model Information

Check product and capacity information to which the remote controller is connected.

- In the service setting list, select model information category, and press [OK] button to move to the detail screen.
- The unit capacity
  - $1 \text{ kWh} = 1 \text{ kBtu} * 0.29307$   
kWh is the result calculated based on Btu, There may be a small difference between calculated and actual capacity.
  - Ex) If the unit capacity is 18 kBtu, it is displayed as 5 kWh.

Service	Back	OK
Service Contact	>	
Model Information	>	
RMC Version Information	>	
Open Source License	>	



Model Information	Back
Indoor Unit   AWHP	
Outdoor Unit   Single	
Capacity   16kW (54/55kBtu/h)	

## RMC Version Information

View the remote controller software version.

- In the service setting list, select the RMC version information and press [OK] button to move to the detail screen

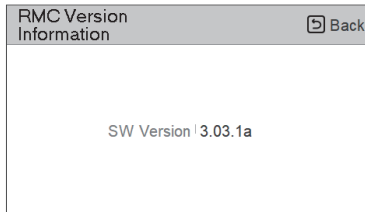
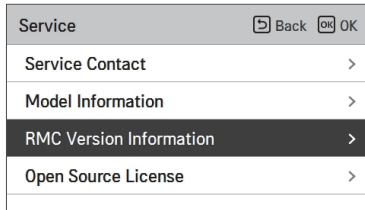

## Open Source License

View the remote controller's open source license.

- In the service setting list, select the open source license category, and press [OK] button to move to the detail screen.

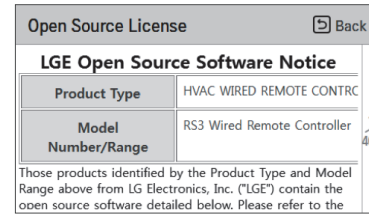
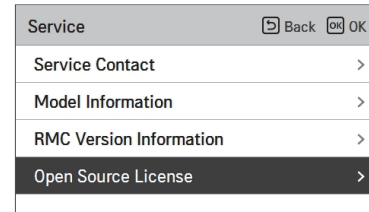

# INSTALLATION

## Installation of Remote Controller

- After fixing the remote controller installation plate on the desired location, fix it firmly with the provided screws.
  - If the installation plate is not flat on the surface, it may result in the controller being twisted and cause a defect.
  - If there is a mounting box, install the remote controller installation plate using the fixings holes which suit, as in the below diagrams.
  - Do not leave a gap with the wall or product loose after the installation.

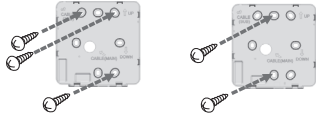

- The wired remote controller cable can be installed in 4 directions. Install to the suitable direction according to the installation environment.
  - Installation direction: Rear entry, top side, right side, left side.
  - When you install the remote controller cable at the top, right and left side, remove the remote controller cable guide hole before the installation.
    - Use a long nose pliers to remove the guide hole.
- After removing the hole, trim the cut surface neatly.

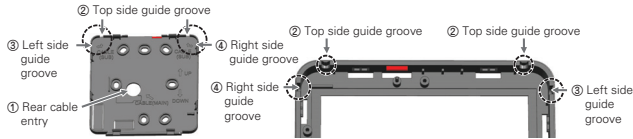

- When installing the remote control cable on the left side, be sure to install it in the following guide.
  - Make the cable to "r" shape as shown below.
  - Fit the bent "r" cable into the upper center piece of case.
  - Tighten the installation plate with preventing interference with the surrounding guide structure.

※ If the cable is assembled in a shape other than "r", it may not be fastened to the installation plate due to interference with the structure of case.



Reference. the bent cable shape



The Upper center boss for fixing the bent cable

- After fixing the remote controller top side on the installation plate attached to the wall as in the following figure, press the bottom side to combine with the installation plate.
  - Do not leave a gap in the top, bottom, left, and right side of the remote controller and the installation plate after combining them.
  - Before combining with the installation plate, arrange the cables to avoid interference with the circuit parts.

### <Order of Combining>

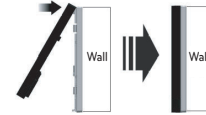

- When you remove the remote controller from the installation plate, insert a small flat head screwdriver into the bottom side separation hole and turn clockwise to separate the remote controller.
  - There are 2 separation holes at the bottom part. Slowly separate one by one.
  - Be careful not to damage the internal parts during the removal.

### <Order of Separation>



- Use the connection cables to connect the indoor unit with the remote controller.

DC 12 V	Red
Signal	Yellow
GND	Black

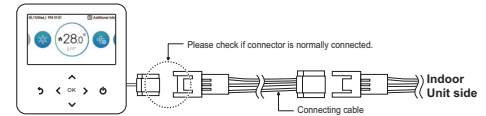

- For the following cases, separately purchase and use the cables suitable for the situation.
  - Do not install the cable over 50 m. (It may cause communication issues.)
  - If the distance between the wired remote controller and the indoor unit is 10 m or more : 10 m extension cable (model name: PZCWRC1)
  - If you control several indoor unit products with one wired remote controller : Group control cable (model name: PZCWRG3)

### NOTE

During the wired remote controller installation, do not bury it in the wall. (It may cause temperature sensor failure.)

Do not install the cable over 50 m. (It may cause communication defect.)

When you install the extension cable, carefully check the direction of the connectors on the remote controller side and the product side before the installation.

Specification of extension cable: AWG 24, 3 conductor or above.

## Group control

1. It is possible to connect 16 indoor units(Max) by one wired remote controller.

※ Connect using the group control cable.

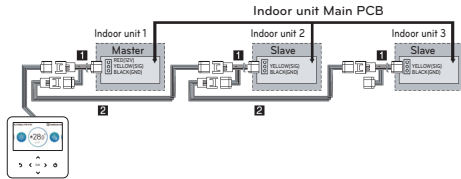

① Group control cable (PZCWRCG3): Connect to indoor unit's wired remote controller connector

② Extension cable (PZCWRC1): Connect to No. ① cable and slave indoor unit's wired remote controller connector

While No. ① cable is connected, connect No. ② cable.



### NOTE

- Connect only GND and signal cable to the indoor unit set as slave. (If power cable is also connected, it may cause loss of communication)
- Inquiries related to the purchase of the cable shall be directed to the specialized company and the service center.

• Change master/slave of the indoor unit.

- For Hydro Kit change the setting with the indoor unit PCB switch.

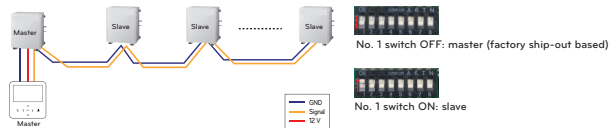

- After completing the master/slave setting in the indoor unit product, turn Off the power of the indoor unit product, and turn On the power after 1 minute.

### NOTE

- During the group control, set only 1 indoor unit as master.
- Indoor unit(Hydro Kit)'s group setting is possible which connected same outdoor unit.
- In case of Group Control, it is possible to use following functions.
  - Selection of operation options (operation/stop/mode/set temperature)
  - It is not possible at some functions.
- During the individual control, if the master indoor unit DIP switch is set to slave, malfunction may occur.

2. You can use two wired remote controllers for one indoor unit.

- A dedicated cable must be used for the connection. If necessary, use an extension cable additionally and install. (2-Remo cable : PZCWRC2, Extension cable : PZCWRC1)
- For normal operation, one should be set as master and the other as slave. (Refer to the function "Installation setting - RMC master/slave")
- After completing the RMC master/slave setting, turn off the power of indoor unit, and turn on the power after 1 minutes.

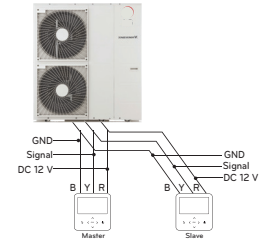

- If you set as Master-Master or Slave-slave for both remote controllers, the following pop-up is displayed once within 10 minutes after power-on.

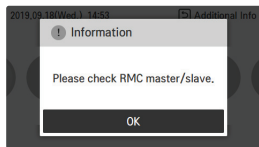

If you use the 2-remo function, through the master remote controller you can check the temperature where the remote controller set as slave is installed.

The room temperature icon changes. This means that the value is detected by the slave remote controller.

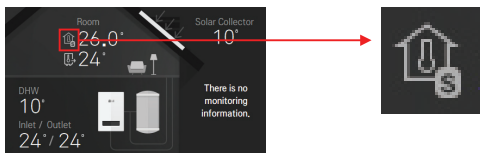

## INSTALLER SETTING

### How to enter installer setting

#### ! CAUTION

The installer setting mode is the mode to set the remote controller's detail function. If the installer setting mode is incorrectly set, it may cause product failure, user's injury, or property damage. It must be set by the installation specialist with the installation license, and if it is installed or changed without installation license, all problems caused will be the responsibility of the installer, and may void the LG warranty.

- In the menu screen, press [←, >] (left/right) button to select the setting category, and press [↑] (up) button for 3 seconds to enter the password input screen for the installer setting.
- Input the password and press [OK] button to move to the installer setting list.

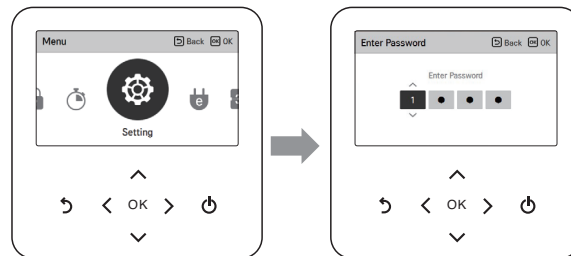

#### \* Installer setting password

Main screen → menu → setting → service → RMC version information → SW Version

Example) SW version : 1.00.1 a

In the above case, the password is 1001.

#### NOTE

Some categories of the installer setting menu may not be available depending on the product function or the menu name may be different.

## Installer setting

- You can set the product user functions.
- Some functions may not be displayed/operated in some product types.

Function	Description
Test Run	Test run operates Multi V in Cooling mode for max 18 minutes.
3 Minutes Delay	Factory use only
Select Temperature Sensor	Selection for setting temperature as air temperature or leaving water temperature or air+leaving water temperature
Dry Contact Mode setting	Dry contact function is the function that can be used only when the dry contact devices is separately purchased and installed.
Central Control address	When connecting the central control, set the central control address of the unit.
Override Master/Slave	Override master/slave selection function is to prevent the unit's different mode operation. If the unit is set as the slave, it is blocked to a change of opposite operating mode(cooling/heating).
Pump Test run	Water pump test run
Air cooling set temp. setting	Adjusting range of 'Setting Air Temperature' in cooling mode
Water cooling set temp. setting	Adjusting range of 'Setting Leaving Water Temperature' in cooling mode
Air heating set temp. setting	Adjusting range of 'Setting Air Temperature' in heating mode
Water heating set temp. setting	Adjusting range of 'Setting Heating Flow Temperature' in heating mode
DHW Set Temp.setting	Setting DHW set temperature
Cooling / Heating only mode	Setting the operation mode lock function.
Screed drying setting	Setting for using Step 1 or 2 capacity of electric
Heater on temperature	Setting outdoor air temperature where half capacity of electric heater starts operation.
Water supply off temp. during cooling setting	Determine leaving water temperature when the unit is turned off. This function is used for preventing condensation on the floor in cooling mode
Outdoor temp. for auto mode	Setting outdoor Min/Max temperature for auto mode.
Indoor air temp. for auto mode	Setting indoor Min/Max temperature for auto mode
LWT for auto mode	Setting heating flow Min/Max temperature for auto mode

Function	Description
Tank disinfection setting 1	Setting start/maintain time for pasteurisation
Tank disinfection setting 2	Setting pasteurisation temperature
Tank setting 1	Setting start temperature for operation
Tank setting 2	Setting maintain temperature for operation
Heater priority	Determine electric heater and water heater on and off
DHW time setting	Determine follow time duration : operation time of domestic hot water tank heating, stop time of domestic hot water tank heating, and delay time of DHW tank heater operating
Use Heating Tank Heater	It is the function to change the setting value of heating tank heater operation such as use / non-use and heater delay time of heating tank heater.
Pump frequency setting (LPM)	Setting for water flow rate in water piping.
TH on/off Variable, heating air setting	Heating air temperature TH On / Off Type setting
TH on/off Variable, heating Water setting	Heating Water Outlet Temperature TH On / Off Type
TH on/off Variable, cooling air setting	Cooling air temperature TH On / Off Type setting
TH on/off Variable, cooling Water setting	Cooling Water Outlet Temperature TH On / Off Type
Heating temp. setting	At the leaving water control in heating mode, the control reference water temperature position setting
Cooling temp. setting	At the leaving water control in cooling mode, the control reference water temperature position setting
Pump setting in heating	Set water pump on / off delay option in heating mode
Pump setting in cooling	Set water pump on / off delay option in cooling mode
Forced operation	Water pump off After 20 consecutive hours, disable / enable the logic that drives the water pump by itself
CN_CC setting	It is the function to set whether to install (use) Dry Contact. (It is not a function for Dry Contact installation, but it is a function to set the usage of the unit's CN_CC port.)
Pump Capacity	Function to change Water Pump Capacity
Pump frequency setting(RPM)	Function to change Water Pump RPM
Smart Grid(SG) setting	Select whether to use or not use the SG Mode function of the product, set the operation option value in SG1 step.
Seasonal auto temp setting	Set the operating temperature in Seasonal Auto mode

Function	Description
Modbus Address	It is function to set the address of the Modbus device that is externally linked to the product. Modbus address setting function is available from indoor unit.
Refrigerant Leak Sensor	The installation of the flare coupling part and the welding part leakage sensor of the indoor unit is set.
IDU Address Verification	Check the result of Auto Addressing of outdoor unit with remote control.
CN_EXT	Function to set external input and output control according to DI / DO set by customer using dry contact port of indoor unit. Determine the use of the contact port (CN_EXT) mounted on the indoor unit PCB
ODU Function Master	Setting of outdoor function Setting function of Master / Slave.
Low Noise Mode Priority	Function to set low noise mode control subject.
Anti-freezing Temperature	This function prevents the product from freezing.
Add Zone	Install additional valve in product to control additional operation area
Use External Pump	Set up to control an external water pump
3rd Party Boiler	Configuration to control 3rd party boiler
Meter Interface	When installing the meter interface to measure energy / calorie in the product, set unit spec for each port
Pump Prerun/Overrun	Set to reach the optimum flow rate by circulating the heating water with the water pump before heat exchange. After the operation stop, additional water pump is activated to circulate the heating water.
Estimated energy display	This function can set to display energy data which outdoor unit estimated power consumption data without wattmeterd.
Zone Setting	When using the zone module, it is the function to set the environment necessary for control such as the number of use and address setting.
Current flow rate	Function to check the current flow rate.
RMC master/slave	This function is to set master / slave to use two remote controllers in one indoor unit.
Data logging setting	Display error history of connected unit
Password Initialization setting	It is the function to initialize (0000) the password when you forgot the password set in the remote controller.

## Test Run

Test run should be performed when charging the additional refrigerant is required. The unit must be operated in Cooling mode when the refrigerant is being charged. Test run instantly makes the unit operate in Cooling mode for 18 minutes.

### NOTE

- If you press any kind of button during this mode, Test Run mode will be finished.
- After the unit operates under Test run mode for 18 minutes, it will be turned off automatically

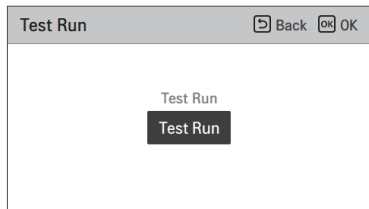
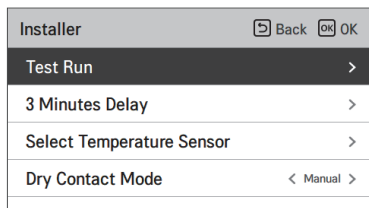

### 3 Minutes Delay

Temporarily eliminates the 3-minute delay function of the outdoor unit Comp

- Factory use only

- In the installer setting list, select 3 Minutes Delay category, and press [OK] button to move to the detail screen.

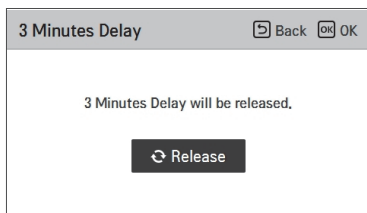
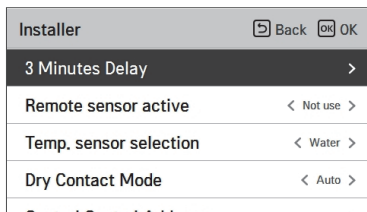

### Select Temperature Sensor

The product can be operated according to air temperature or leaving water temperature. The selection for setting temperature as air temperature or leaving water temperature is determined.

- In the installer setting list, Select Temperature Sensor category, and press [OK] button to move to the detail screen.

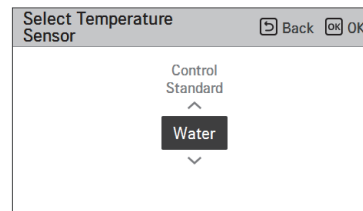
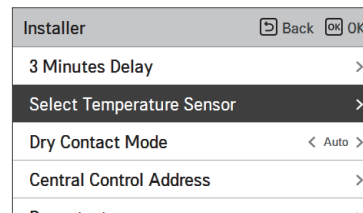

Value		
Water	Air	Air+Water

## Dry Contact Mode

Dry contact function is the function that can be used only when the dry contact devices is separately purchased and installed.

- Change setting values using [←,→(left/right)] button.

Installer	
3 Minutes Delay	>
Remote sensor active	< Not use >
Temp. sensor selection	< Water >
<b>Dry Contact Mode</b>	< Auto >
Central Control Address	>

Value
Auto
manual

### NOTE

For dry contact mode related detail functions, refer to the individual dry contact manual.  
What is dry contact?

It means the contact point signal input when the hotel card key, human body detection sensor, etc. are interfacing with the air conditioner.

Added system functionality by using external inputs (dry contacts and wet contacts).

## Central Control Address

When connecting the central control, set the central control address of the unit.

- In the installer setting list, select Central Control Address category, and press [OK] button to move to the detail screen.

Installer	
Central Control Address	>
Air cooling set temp.	>
Water cooling set temp.	>
Air heating set temp.	>
Water heating set temp.	>

↓ OK

Central Control Address	
Address Code(Hex)	
↑	↓
0	0

### NOTE

Enter address code as hexadecimal value

Front: Central Control Gr. No.

Back side: Central control indoor the number

### NOTE

This function is not available for monobloc

## Override Master/Slave

Override master/slave selection function is to prevent the unit's different mode operation. If the unit is set as the slave, it is blocked to a change of opposite operating mode(cooling/heating).

- Change setting values using [ $\leftarrow$ , $\rightarrow$ ] button.

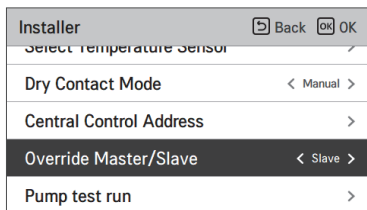

M/S	Description
Master	Using group control, this master sets the mode of slave IDU's.
Slave	If the unit is set as the slave, it blocks a change of opposite operating mode(cooling/heating)

### NOTE

Override M/S setting function is only available in some products.

## Pump test run

The pump test run is the function to test run by operating the water pump. This function can be used for air vents / flow sensors and others.

- In the installer setting list, Pump Test run category, and press [OK] button to move to the detail screen.

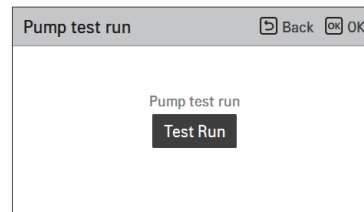
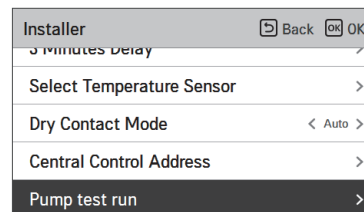

## Air cooling set temp

Determine cooling setting temperature range when air temperature is selected as setting temperature.

- In the installer setting list, select Air cooling set temp category, and press [OK] button to move to the detail screen.

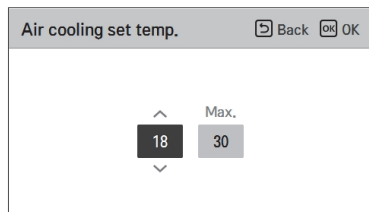
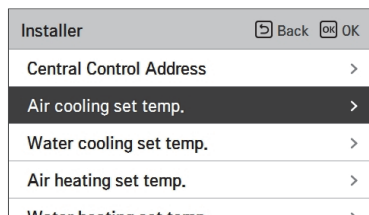

### NOTE

The setting range differs depending on the connected product.

## Water cooling set temp

Determine cooling setting temperature range when leaving water temperature is selected as setting temperature.

- In the installer setting list, select water cooling set temp category, and press [OK] button to move to the detail screen.

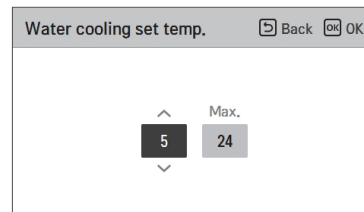
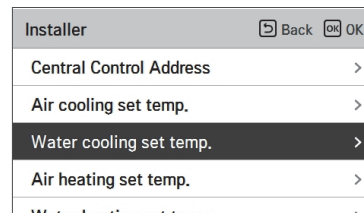

### NOTE

Water condensation on the radiator

- While cooling operation, cold water may not flow to the radiator. If cold water enters to the radiator, dew generation on the surface of the radiator can be occurred.
- The setting range differs depending on the connected product.

## Air heating set temp

Determine heating setting temperature range when air temperature is selected as setting temperature

- In the installer setting list, select Air heating set temp. category, and press [OK] button to move to the detail screen.

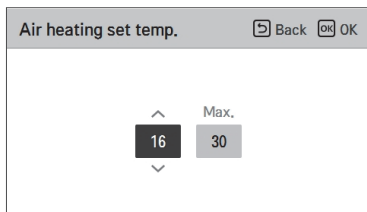
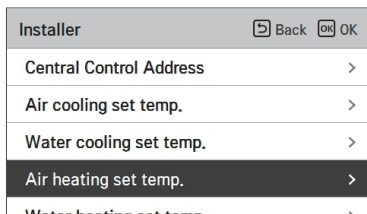

### NOTE

The setting range differs depending on the connected product.

## Water heating set temp

Determine heating setting temperature range when leaving water temperature is selected as setting temperature

- In the installer setting list, select Water heating set temp. category, and press [OK] button to move to the detail screen.

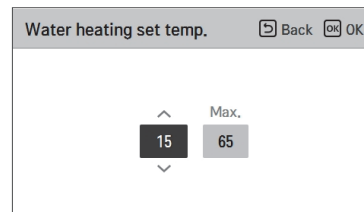
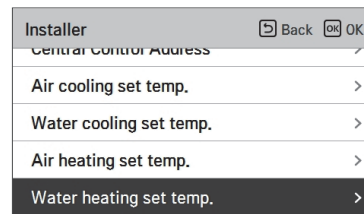

### NOTE

The setting range differs depending on the connected product.

## DHW set temp

Determine heating setting temperature range when DHW temperature is selected as setting temperature

- In the installer setting list, select DHW set temp. category, and press [OK] button to move to the detail screen.

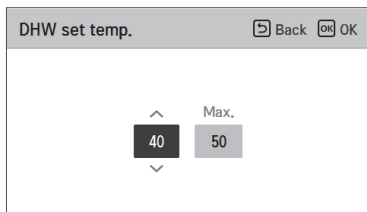
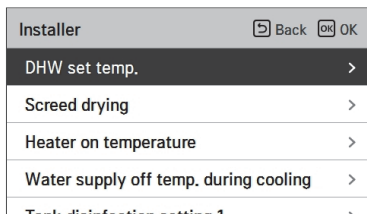

### NOTE

The setting range differs depending on the connected product.

## Cooling / Heating only mode

Set the Operation mode lock when Multi V Indoor unit is used only cooling mode in summer and Hydro Kit is used only heating in winter.

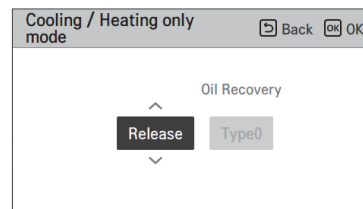
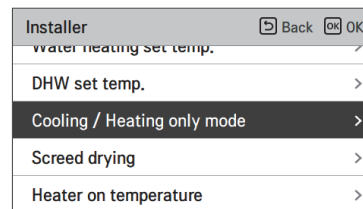

Value1	Value2 (Oil Recovery)
Release	-
Set	Type 0
	Type 1

## Screed drying

This function is a unique feature of AWHP that, when AWHP is installed in a new concrete structure, controls the specific temperature floor heating out temperature for a certain period of time to cure the floor cement.

- In the installer setting list, select Screed drying category, and press [OK] button to move to the detail screen.

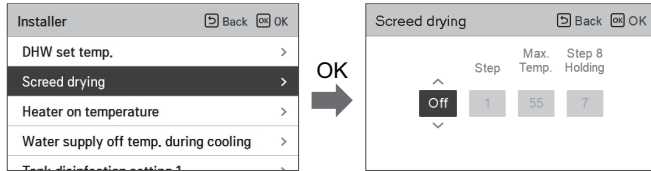

### How to display

Main Screen - Displays 'Screed drying' on the desired temperature display. The step in progress at the bottom of the display is displayed.

### Setting value

- Start-up step: 1~11
- Maximum temperature : 35 °C~55 °C
- Step 8 Holding time : 1 days~30 days

### Function operation

- It is performed by the following procedure from the selected starting step.
- After all steps are completed, turn off the cement curing operation.

Step	1	2	3	4	5	6	7	8	9	10	11
Leaving Water target temperature[°C]	25	Max.T	Off	25	35	45	Max.T	Max.T	45	35	25
Duration [hours]	72	96	72	24	24	24	24	Holding time	72	72	72

- \* If the upper limit setting value of the heating LW temperature is 55 °C or lower, it is set to 55 °C forcibly.
- If the lower limit setting value of the heating LW temperature is 25 °C or higher, it is set to 25 °C forcibly.

## NOTE

- During Screed drying operation, button input except for installer function and temperature display is restricted.
- When the power is applied again after a power outage during product operation, the product operation state before power failure is remembered and the product is automatically operated.
- Screed drying operation stops when an error occurs / When error is cleared, restart cement Screed drying. (However, if the wired remote control is reset to the error occurrence state, it is compensated in the unit of one day)
- Upon releasing after an error, Screed drying operation may take up to 1 minute of waiting time after boot up. (The Screed drying operation status is judged as 1 minute cycle.)
- During Screed drying operation, installer function Screed drying operation is selectable.
- During Screed drying operation, starting operation, low noise mode off, low noise time setting off, hot water off, solar heat off.
- During Screed drying operation, simple, sleep, on, off, weekly, holiday, heater does not execute reservation operation.

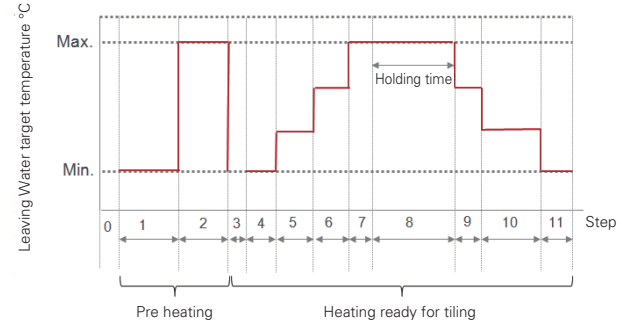

## Heater on temperature

Depending on local climatic conditions, it is necessary to change the temperature condition in which electric heater turns on / off.

- In the installer setting list, Heater on temperature category, and press [OK] button to move to the detail screen.

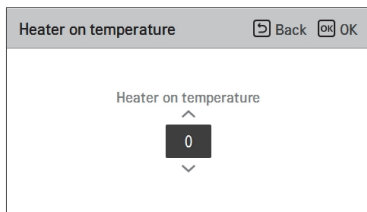
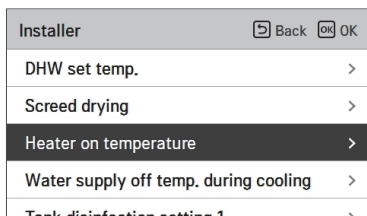

### NOTE

The setting range differs depending on the connected product.

### NOTE

#### • Heater on temperature

Using Half capacity of electric heater : when DIP Switch No. 6 and 7 is set as 'OFF-ON' :

- Example : If Heater on temperature is set as '-1' and DIP switch No 6. and 7 is set as 'OFF-ON', then half capacity of electric heater will start operation when outdoor air temperature is below -1 °C and current leaving water temperature or room air temperature is much below than target leaving water temperature or target room air temperature.

Using Full capacity of electric heater : when DIP Switch No. 6 and 7 is set as 'OFF-OFF' :

- Example : If Heater on temperature is set as '-1' and DIP switch No 6. and 7 is set as 'OFF-OFF', then full capacity of electric heater will start operation when outdoor air temperature is below -1 °C and current leaving water temperature or room air temperature is much below than target leaving water temperature or target room air temperature.

## Water supply off temp. during cooling

Determine leaving water temperature when the unit is turned off. This function is used for preventing condensation on the floor in cooling mode

- In the installer setting list, select Water supply off temp. during cooling category, and press [OK] button to move to the detail screen.

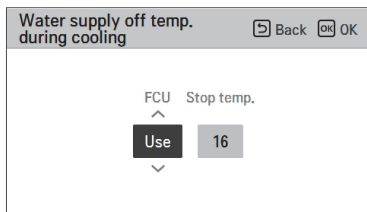
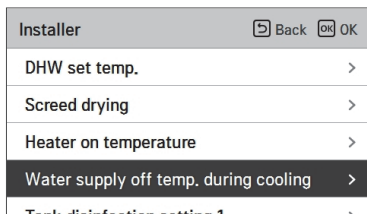

Function	Value	Default	Setting Rang
cooling water temperature	Water supply off temperature	16	25~16
	FCU Use / not use	use	Use / Not Use

- Stop temp. : cut-off temperature. Stop temp. is valid when FCU is installed.
- FCU : determines if FCU is installed or not.
- Example : If Stop temp. is set as '10' and FCU is 'Use' and actually FCU is NOT installed in the water loop, the unit stop operation in cooling mode when the leaving water temperature is below 10 °C.
- Example : If Stop temp. is set as '10' and FCU is 'Not use' and actually FCU is installed in the water loop, the Stop temp. is not used and the unit do NOT stop operation in cooling mode when the leaving water temperature is below 10 °C.

## CAUTION

FCU Installation

- If FCU is used, related 2way valve should be installed and connected to the unit PCB.
- If FCU is set as 'Not use' but FCU or 2way valve is NOT installed, the unit can do abnormal operation.

## Outdoor temp. for auto mode

It is the function to set outdoor Min/Max temperature for auto mode.

Installer <span>Back</span> <span>OK</span>	
water supply on temp. during cooling	>
<b>Outdoor temp. for auto mode</b>	>
Indoor air temp. for auto mode	>
LWT for auto mode	>
Tank disinfection setting 1	>



Outdoor temp. for auto mode <span>Back</span> <span>OK</span>	
Min.	Max.
^	
-10	15
v	

### NOTE

The setting range differs depending on the connected product.

## Indoor air temp. for auto mode

It is the function to set indoor Min/Max temperature for auto mode.

Installer <span>Back</span> <span>OK</span>	
water supply on temp. during cooling	>
Outdoor temp. for auto mode	>
<b>Indoor air temp. for auto mode</b>	>
LWT for auto mode	>
Tank disinfection setting 1	>



Indoor air temp. for auto mode <span>Back</span> <span>OK</span>	
Min.	Max.
^	
16	30
v	

### NOTE

The setting range differs depending on the connected product.

## LWT for auto mode

It is a function to set the heating flow Min/Max temperature for auto mode.

Installer	Back	OK
Water supply on temp. during cooling	>	
Outdoor temp. for auto mode	>	
Indoor air temp. for auto mode	>	
<b>LWT for auto mode</b>	>	
Tank disinfection setting 1	>	



LWT for auto mode	Back	OK
Min.	Max.	
15	65	

### NOTE

The setting range differs depending on the connected product.

## Tank disinfection setting 1, 2

- Disinfection operation is special DHW tank operation mode to kill and to prevent growth of viruses inside the tank.
  - Disinfection active : Selecting enable or disable of disinfection operation.
  - Start date : Determining the date when the disinfection mode is running.
  - Start time : Determining the time when the disinfection mode is running.
  - Max temp. : Target temperature of disinfection mode.
  - Duration time : Duration of disinfection mode.

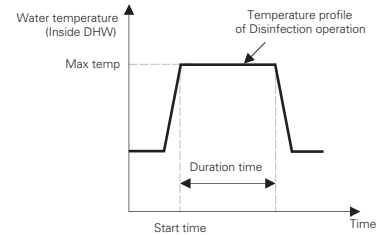

Installer	Back	OK
<b>Tank disinfection setting 1</b>	>	
Tank disinfection setting 2	>	
Tank setting1	>	
Tank setting2	>	



Tank disinfection setting 1	Back	OK
Disinfection active	Start date	Start time
Not use	Fri.	23

Installer	Back	OK
Tank disinfection setting 1	>	
<b>Tank disinfection setting 2</b>	>	
Tank setting1	>	
Tank setting2	>	



Tank disinfection setting 2	Back	OK
Max temp.	Duration time	
70	10	

### NOTE

DHW heating should be enable

- If Disinfection active is set as 'Not use', that is 'disable disinfection mode', Start date and Start time is not used.

## Tank setting 1

- In the installer setting list, select tank setting 1 category, and press [OK] button to move to the detail screen.

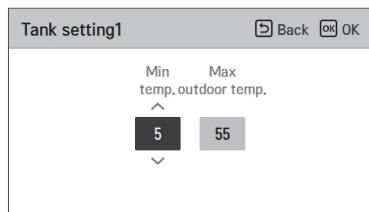
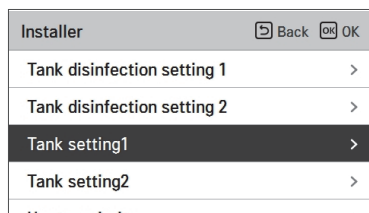

### NOTE

The setting range differs depending on the connected product.

## Tank setting 2

- In the installer setting list, select tank setting 2 category, and press [OK] button to move to the detail screen.

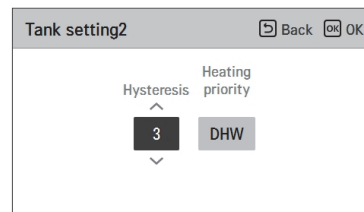
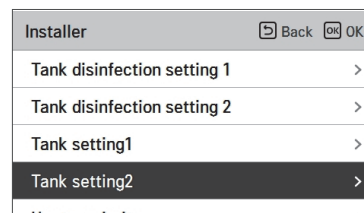

Value	Range
Hysteresis	4~2
Heating priority	Floor heating / DHW

### • Tank setting 1, 2

Descriptions for each parameters are as following.

- Min temp. : temperature gap from Max outdoor temp.
- Max outdoor temp. : maximum temperature generated by AWHP compressor cycle.
- Example : If Min temp. is set as '5' and Max outdoor temp. is set as '48', then Session A (see the graph) will be started when the water tank temperature is below 45 °C.... If temperature is above 48 °C...., then Session B will be started.
- Hysteresis : temperature gap from target DHW temperature. This value is required to frequent On and Off of water tank heater.
- Heating priority : Determining heating demand priority between DHW tank heating and under floor heating.
- Example : If user's target temperature is set as '70' and Hysteresis is set as '3', then the water tank heater will be turned off when the water temperature is above 73 °C. The water tank heater will be turned on when the water temperature is below 70 °C.
- Example : If Heating priority is set as 'DHW', that means heating priority is on DHW heating, DHW is heated by AWHP compressor cycle and water heater. In this case the under floor can not be heated while DHW heating. On the other hand, if the Heating priority is set as 'Floor heating', that means heating priority is on under floor heating, DHW tank is ONLY heated by water heater. In this case the under floor heating is not stopped while DHW is heated.

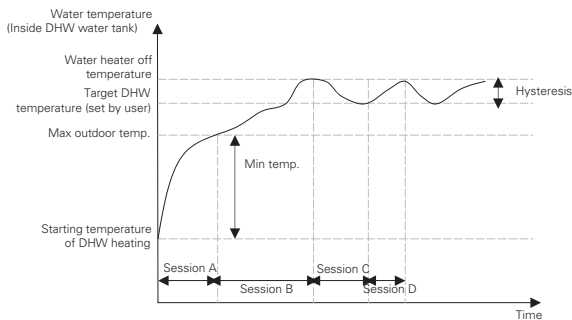

Session A : Heating by AWHP compressor cycle and water heater  
 Session B : Heating by water heater  
 Session C : No heating (Water heater is Off)  
 Session D : Heating by water heater

### NOTE

DHW heating does not operate when it is disabled.

### Heater priority

- Heater priority : determine electric heater and DHW tank heater on and off.
- Example : If Heater priority is set as 'Main+Boost heater ON', then electric heater and DHW tank heater are on and off according to control logic. If Heater priority is set as 'Boost heater only ON', then electric heater is never turned on and only DHW tank heater is on and off according to control logic.
- In the installer setting list, heater priority category, and press [OK] button to move to the detail screen.

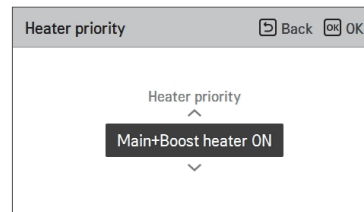
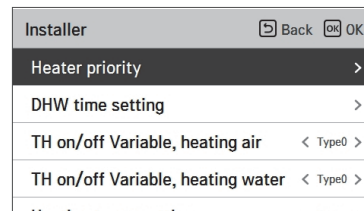

Value	
Boost heater only ON	Main+Boost heater ON

### DHW time setting

Determine following time duration : operation time of DHW tank heating, stop time of DHW tank heating, and delay time of DHW tank heater operating.

- Active time : This time duration defines how long time DHW tank heating can be continued.
- Stop time : This time duration defines how long time DHW tank heating can be stopped. It also regarded as time gap between DHW tank heating cycle.
- Boost heater delay time : This time duration defines how long time DHW tank heater will not be turned on in DHW heating operation.
- Example of timing chart :

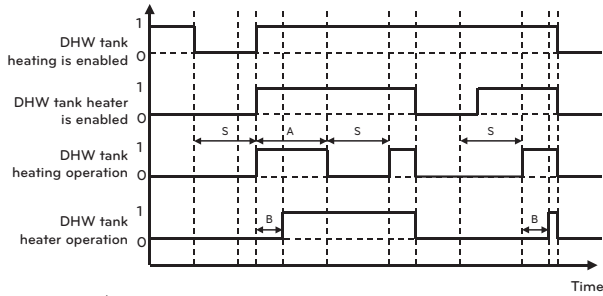

- \* 1=active / 0=not active
- \* A = Active time
- \* S = Stop time
- \* B = Boost heater delay time

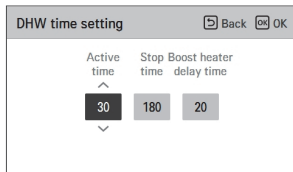
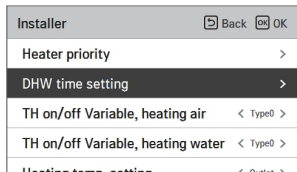

### Use Heating Tank Heater

It is the function to change the setting value of heating tank heater operation such as use / non-use and heater delay time of heating tank heater

- Change setting values using [**<**,**>**](left/right) button.

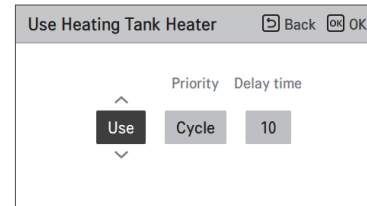
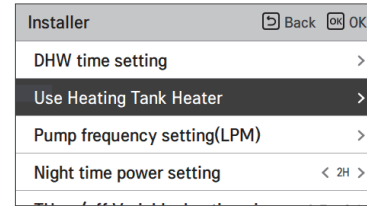

Value1	Value2	Value3
Use/Not Use	Priority	Delay time
Not use	-	-
Use disinfect	-	-
Use	Cycle	10, 20, 30, 40, 50, 60, 90, 120, 1440
	Heater / Cycle	

## Pump frequency setting (LPM)

It is a function to set for water flow rate in water piping.

Installer	Back	OK
Heater priority		>
DHW time setting		>
Use Heating Tank Heater		>
<b>Pump frequency setting(LPM)</b>		>
Night time power setting	< 2H >	



Pump frequency setting(LPM)	Back	OK
Pump frequency setting(LPM)		
^ <div style="border: 1px solid black; padding: 2px; display: inline-block;">92</div> v		

<b>Range</b>
15 ~ 92 LPM

## TH on/off Variable, heating air

It is a function to adjust the heating air temperature Thermal On / Off temperature according to the field environment in preparation for heating or heating claim.

- You can set the following setting values using [<,>(left/right)] button.

Installer	Back	OK
Heater priority		>
DHW time setting		>
<b>TH on/off Variable, heating air</b>	< Type0 >	
TH on/off Variable, heating water	< Type0 >	
Heating temp setting	< Type0 >	

Value	Description	
	TH On	TH Off
Type0	-0.5 °C	1.5 °C
Type1	-1 °C	2 °C
Type2	-2 °C	3 °C
Type3	-3 °C	4 °C

## TH on/off Variable, heating water

It is a function to adjust the heating water temperature Thermal On / Off temperature according to the field environment in preparation for heating or heating claim.

- You can set the following setting values using [

Installer		Back	OK
Heater priority	>		
DHW time setting	>		
TH on/off Variable, heating air	< Type0 >		
<b>TH on/off Variable, heating water</b>	<b>&lt; Type0 &gt;</b>		
Heating temp. setting	< Type0 >		

Value	Description	
	TH On	TH Off
Type0	-2 °C	2 °C
Type1	-3 °C	3 °C
Type2	-4 °C	4 °C
Type3	-1 °C	1 °C

## TH on/off Variable, cooling air

It is a function to adjust the cooling air temperature Thermal On / Off temperature according to the field environment in preparation for cooling or cooling claim.

- You can set the following setting values using [

Installer		Back	OK
TH on/off Variable, heating air	< Type0 >		
TH on/off Variable, heating water	< Type0 >		
<b>TH on/off Variable, cooling air</b>	<b>&lt; Type0 &gt;</b>		
TH on/off Variable, cooling water	< Type0 >		
Pump setting in heating	>		

Value	Description	
	TH On	TH Off
Type0	0.5 °C	-0.5 °C
Type1	1 °C	-1 °C
Type2	2 °C	-2 °C
Type3	3 °C	-3 °C

## TH on/off Variable, cooling water

It is a function to adjust the cooling water temperature Thermal On / Off temperature according to the field environment in preparation for cooling or cooling claim.

- You can set the following setting values using [←,→(left/right)] button.

Installer		Back	OK
TH on/off Variable, heating air	<	Type0	>
TH on/off Variable, heating water	<	Type0	>
TH on/off Variable, cooling air	<	Type0	>
TH on/off Variable, cooling water	<	Type0	>
Pump setting in heating			

Value	Description	
	TH On	TH Off
Type0	0.5 °C	-0.5 °C
Type1	1 °C	-1 °C
Type2	2 °C	-2 °C
Type3	3 °C	-3 °C

## Heating temp. setting

- At the leaving water control in heating mode, the control reference water temperature position setting
- If the air / leaving water temperature selection setting is set to leaving water temperature
- Change setting values using [←,→(left/right)] button

Installer		Back	OK
heater priority			✓
DHW time setting			>
TH on/off Variable, heating air	<	Type0	>
TH on/off Variable, heating water	<	Type0	>
Heating temp. setting	<	Outlet	>

Value	
Outlet (Default)	Inlet

## Cooling temp. setting

- At the leaving water control in cooling mode, the control reference water temperature position setting
- If the air / leaving water temperature selection setting is set to leaving water temperature
- Change setting values using [←,→(left/right)] button

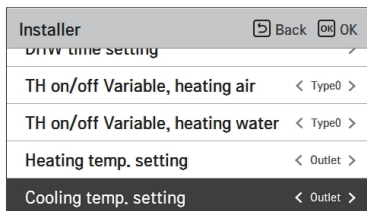

Value	
Outlet (Default)	Inlet

## Pump setting in heating

- It is a function to help the water pump's mechanical life by putting the water pump's rest time
- Installer setting function to set water pump operation / delay time option in heating mode
- In the installer setting list, select Pump setting in heating category, and press [OK] button to move to the detail screen.

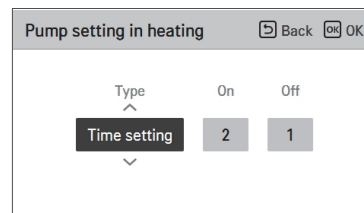
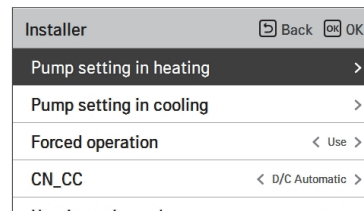

Type	Time setting	Operation continue
On	1 Minute~60 minutes	-
Off	1 Minute~60 minutes	-

## Pump setting. in cooling

- It is a function to help the water pump's mechanical life by putting the water pump's rest time
- installer setting function to set water pump operation / delay time option in cooling mode
- In the installer setting list, select Pump setting in cooling category, and press [OK] button to move to the detail screen.

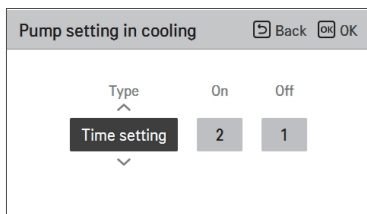
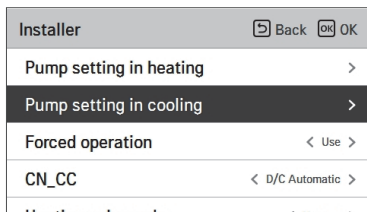

Type	Time setting	Operation continue
On	1 Minute~60 minutes	-
Off	1 Minute~60 minutes	-

## Forced operation

- If the product is not used for a long time, the product will be forced to operate to prevent pump failure and PHEX freezing
- Water pump off After 20 consecutive hours, disable / enable the logic that drives the water pump by itself
- In the installer setting list, select Forced operation category, and press [OK] button to move to the detail screen

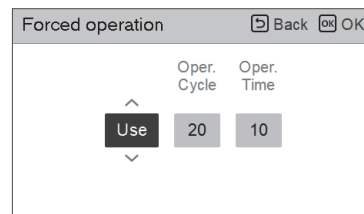
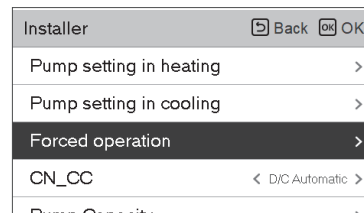

Type	Use	Not use
Oper. Cycle	20 minutes~60 minutes	-
Oper. Time	1 Minute~60 minutes	-

## CN\_CC

It is the function to set the usage of the unit's CN\_CC port.

- Change setting values using [←,→(left/right)] button

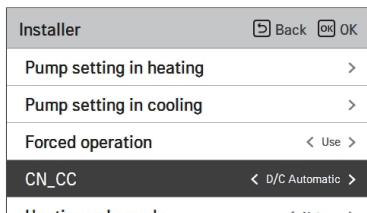

Value	Description
D/C Automatic	When power is applied to the product, the unit when the contact point is on in Dry Contact installed state recognizes Dry Contact installation
D/C Not Installed	Do not use (install) Dry Contact
D/C Installed	Use (install) Dry Contact

### NOTE

CN\_CC is the device connected to the unit to recognize and control the external contact point.

## Pump Capacity

It is a function to enable installer to control Pump capacity application model.

- In the installer setting list, select Pump Capacity category, and press [OK] button to move to the detail screen.

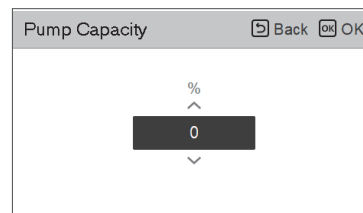
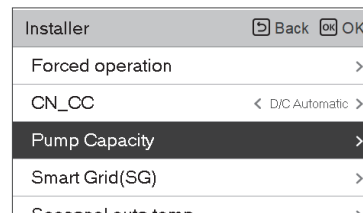

Value	Description
100 (Default)	10~100 : % Change unit: 5

## Pump frequency setting (RPM)

It is a function to enable installer to control pump RPM of BLDC pump application model.

- In the installer setting list, select Pump frequency setting(RPM) category, and press [OK] button to move to the detail screen.
- The function is not available for some products.

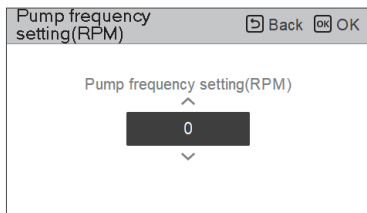
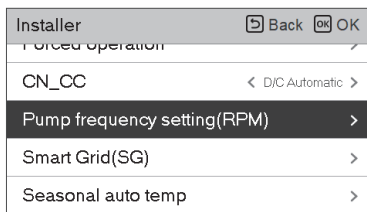

Value	Description
3 500	500~3 700 : RPM Change unit : 10

## Smart Grid(SG)

It is the function to enable / disable the SG Ready function and to set the reference value at SG2 step.

- In the installer setting list, select Smart Grid(SG) category, and press [OK] button to move to the detail screen.

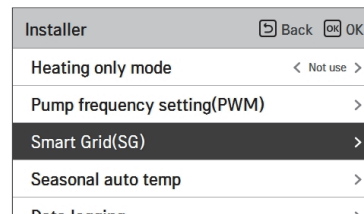

Value	Mode
Not use (Default)	-
Use	Step 0
	Step 1
	Step 2

## Seasonal auto temp

It is the function to set the operation reference value in Seasonal Auto mode.

- In the installer setting list, select Seasonal auto temp category, and press [OK] button to move to the detail screen.

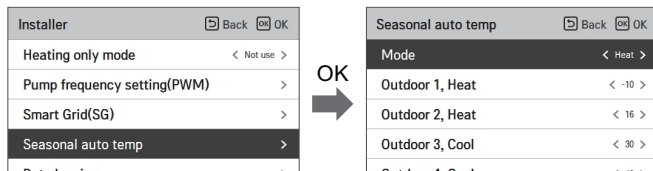

Function	Description	Boundary	Set Point in graph	Attribute
Outdoor1,Heat (Out1)	Heating lower ambient temp	$Out1 \leq Out2-1$	Set point 5	Outdoor Air Temp.
Outdoor2,Heat (Out2)	Heating higher ambient temp	$Out2 \geq Out1 +1$ $Out2 \leq Out3 -5$	Set point 6	Outdoor Air Temp.
Outdoor3,Cool (Out3)	Cooling lower ambient temp	$Out3 \geq Out2 +5$ $Out3 \leq Out4 -1$	Set point 7	Outdoor Air Temp.
Outdoor4,Cool (Out4)	Cooling higher ambient temp	$Out4 \geq Out3 +1$	Set point 8	Outdoor Air Temp.
Water1,Heat (LW1)	Heating higher water temp	$LW1 \geq LW2$	Set point 1	Auto Adjustable Target Temp.
Water 2,Heat (LW2)	Heating lower water temp	$LW1 \geq LW2$	Set point 2	Auto Adjustable Target Temp.
Water3,Cool (LW3)	Cooling higher water temp	$LW3 \geq LW4$	Set point 3	Auto Adjustable Target Temp.
Water4,Cool (LW4)	Cooling lower water temp	$LW3 \geq LW4$	Set point 4	Auto Adjustable Target Temp.
Air 1, Heat (RA1)	Heating higher air temp	$RA1 \geq RA2$	Set point 1	Auto Adjustable Target Temp.
Air 2, Heat (RA2)	Heating lower air temp	$RA1 \geq RA2$	Set point 2	Auto Adjustable Target Temp.
Air 3, Cool (RA3)	Cooling higher air temp	$RA3 \geq RA4$	Set point 3	Auto Adjustable Target Temp.
Air 4, Cool (RA4)	Cooling lower air temp	$RA3 \geq RA4$	Set point 4	Auto Adjustable Target Temp.

- Setting range: Celsius

- Seasonal Auto Driving mode: Heating, Heating & Cooling, Air-conditioning

\* If heating mode is selected, heating & cooling or cooling can not be selected.

- Depending on the air / outflow control selection value, the water / air related setting value is displayed on the screen.

In this mode, setting temperature will follow outdoor temperature automatically. This mode adds the cooling season function to the conventional weather dependent operation mode.

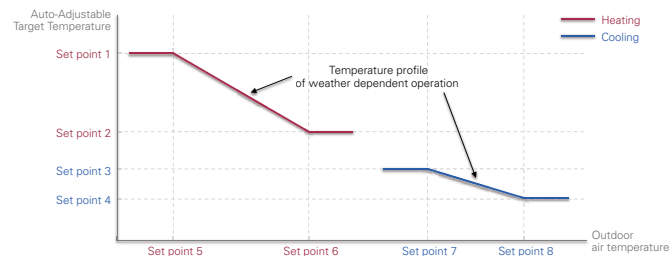

## Modbus Address

It is function to set the address of the Modbus device that is externally linked to the product. Modbus address setting function is available from indoor unit.

- In the installer setting list, select Modbus Address , and press [OK] button to move to the detail screen.

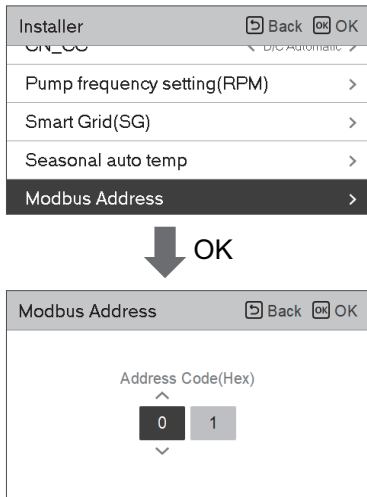

### NOTE

To use this function, switch No.1 of option switch 1 must be turned ON.

## Refrigerant Leak Sensor

The installation of the flare coupling part and the welding part leakage sensor of the indoor unit is set.

- Change setting values using [ <, > ] (left/right) button.

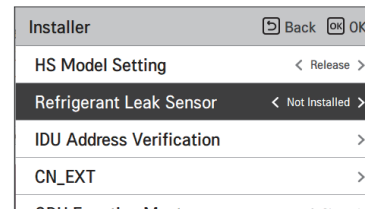

Value
Installed
Not Installed

## IDU Address Verification

Check the result of Auto Addressing of outdoor unit with remote control.

- In the installer setting list, select the indoor unit address check category, and press [OK] button to move to the detail screen.

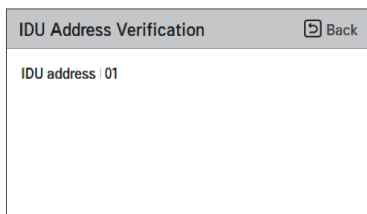
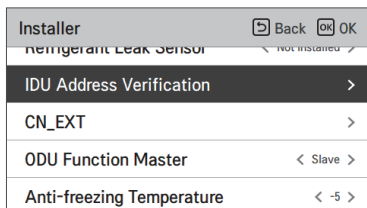

## CN\_EXT

It is a function to control external input and output according to DI type set by customer using CN-EXT Port.

- In the installer setting list, select CN-EXT Port category, and press [OK] button to move to the detail screen.

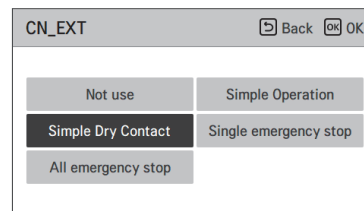
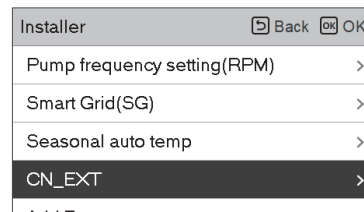

Value				
Not use	Simple Operation	Simple Dry Contact	Single emergency stop	All emergency stop

## ODU Function Master

It is the function to set the outdoor unit's function Master / Slave.

- Change setting values using [,<,>(left/right)] button.

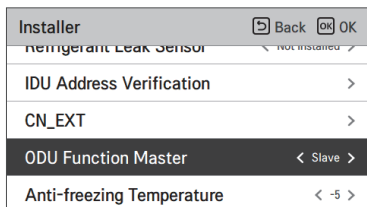

Value	Description
Slave	No noise operation control subject setting No noise operation time setting No defrost mode setting
Master	Low noise operation control subject can be set Low noise operation time setting Defrost mode can be set



## CAUTION

※When you change the outdoor unit function master setting from master to slave, check the operation status of the outdoor unit function (outdoor unit low noise operation, smart load control) and make sure to stop the outdoor unit function before the change.

## Low Noise Mode Priority

It is the function to set the low noise mode control main agent. (It is the function to set that only one of the outdoor unit / remote controller can control the low noise operation.)

- Change setting values using [,<,>(left/right)] button.

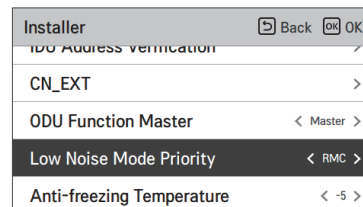

Value	Description
RMC	Low noise operation switch setting of outdoor unit PCB is ignored. Function Setting - Low noise operation time menu is activated.
ODU(default)	It is controlled by outdoor unit according to switch setting value of low noise operation of outdoor unit PCB. Function Setting - Low noise operation time menu is inactivated

## Anti-freezing Temperature

Anti-freeze temperature setting is available in installer mode. It prevents frostbite from happening in the range of -25 to -5 degree celsius.

- Change setting values using [ <, > (left/right) ] button

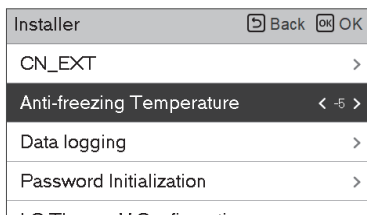

### NOTE

To use this function, the antifreeze short pin must be open and switch No.2 in Option SW 3 must be on.

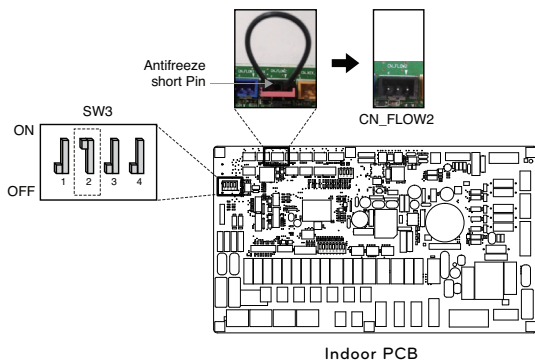

## Add Zone

Function to set whether or not to use a installed 2nd circuit function using mixing kit.

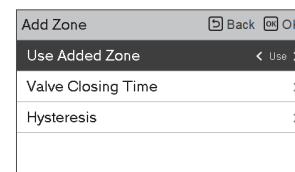
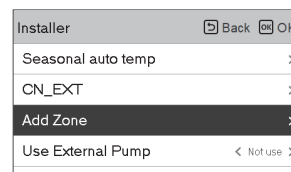

You can set valve closing time[sec] and hysteresis temperature[ °C] on screen by yourself.



Activating this function, It allows 2 zones(Room1, Room2) temperature to be controlled, separately.

- In case of heating, the temperature of Room1 can not be set higher than Room2 temperature.
- In case of cooling, the temperature of Room1 can not be set lower than Room2 temperature.

Setting range

- Add Zone (2nd Circuit function setting) : Use / Not Use
- Value Closing Time : 60~999 seconds (Default: 240)
- Hysteresis (Thermal On / Off) : 1~5 °C (Default: 2)

## Use External Pump

This function can be set to control the external water pump.

- In the installer setting list, select Use External Pump category, and press [OK] button to move to the detail screen.

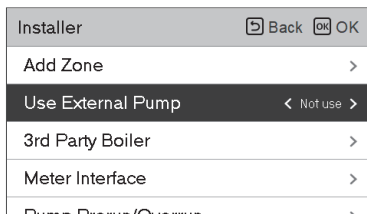

Value	
Not use	Use

## 3rd Party Boiler

This function is to configure the 3rd party boiler to be controlled.

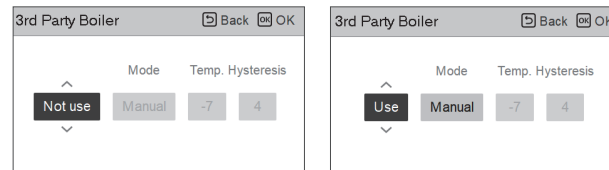

If the status of this function is "Use", you can choose control mode of boiler, Auto or Manual.

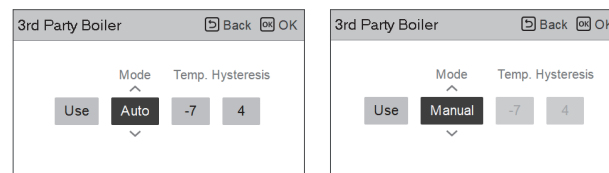

If the mode of this function is set to "Auto", you can set temperature of the boiler and hysteresis, respectively.

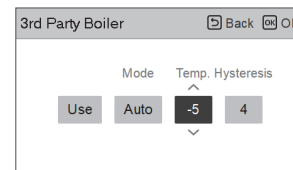

External boiler ON condition :

- If outdoor temperature  $\leq$  external boiler operation temperature value (installer setting), turn off the indoor unit and operate the external boiler.

External boiler OFF condition :

- If External air temperature  $\geq$  external boiler operation temperature value (installer setting) + Hysteresis (installer setting), turn off external boiler operation and operate indoor unit

## Meter Interface

It is the function that can check the status of energy and power on screen. It collects and calculates power or calorie data to create data for energy monitoring and energy warning alarm pop-ups. This function can be activated in installer mode.

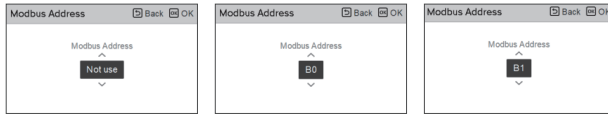
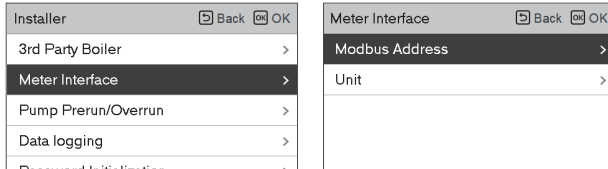

There are 2 options, modbus address and unit, in this function. Activating the modbus address option, you choose one address(B0 or B1) or don't use. Then, you set the port and specification in range of 0000.0~9999.9 [pulse/ kWh] as shown in the figure below.

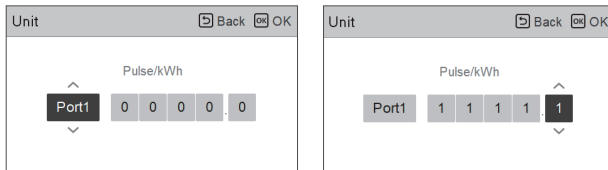

## Estimated energy display

This function can set to display energy data which outdoor unit estimated power consumption data without wattmeter.

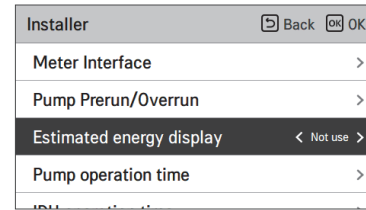

Setting value	Description
Use	Display energy consumption data which outdoor unit estimated
Not Use	Not display energy consumption data which outdoor unit estimated

## Pump Prerun/Overrun

Pump Prerun operates to ensure sufficient flow before the compressor is operated. This is a function that allows heat exchange to work smoothly.

Pump Overrun is a function to prevent water pump failure and to help mechanical life. If the water pump has been off for 20 hours, Water pump will operate for the set time

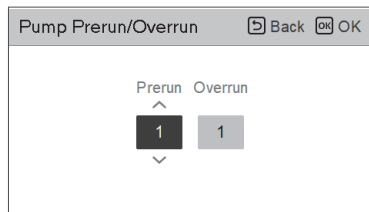
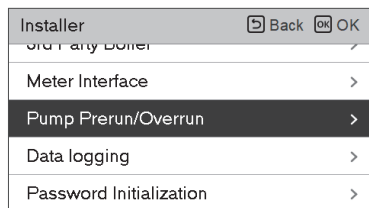

### NOTE

The setting range differs depending on the connected product.

## Solar Thermal System

It is function to set operation reference value in Solar Thermal System.

In the installer setting list, select Solar thermal system category, and press [OK] button to move to the detail screen.

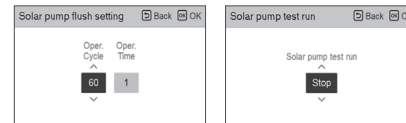
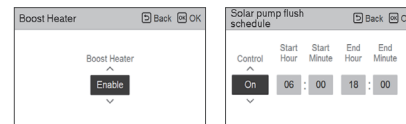
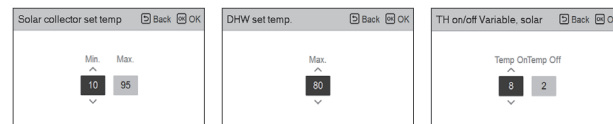
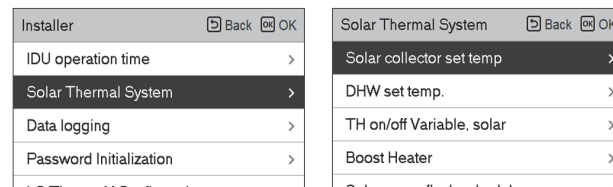

### NOTE

To use this function, switch No.2 of option switch 2 must be turned ON and No.3 of option switch 2 must be turned OFF.

**Descriptions for each parameters are as following.**

- Solar collector set temp
  - Min temp : It is the minimum solar collector temperature at which the solar thermal system can operate.
  - Max temp : It is the maximum solar collector temperature at which the solar thermal system can operate
- TH on/off Variable, solar
  - Temp on : It is the temperature difference between the current solar thermal temperature and DHW tank temperature at which the solar thermal system operates.
  - Temp off : It is the temperature difference between the current solar thermal temperature and DHW tank temperature at which the solar thermal system stops.
  - Example : If the current solar collector temperature is 80 °C and Temp on is set to 8 °C, the solar thermal system operates when the DHW tank temperature is less than 72 °C. In the same case, if Temp off is set to 2 °C, Solar Thermal System stops when DHW temperature is 78 °C.
- DHW Set Temp
  - Max : It is maximum temperature of DHW that can be reached by solar thermal system.
- Boost Heater
  - Enable : DHW tank heater can be used when operating the Solar Thermal system.
  - Disable : DHW tank heater cannot be used when operating the Solar Thermal system.
- Solar pump flush schedule
  - It is the function to circulate the solar water pump intermittently for solar collector temperature detection when the solar water pump does not operate for a long time. Turn on to use this function.
- Solar Pump flush setting
  - Oper.Cycle : When using the solar pump flush function, the solar water pump operates at the set time.
  - Oper.Time : When using the solar pump flush function, the solar water pump operates during the set time.

Function	Value	Range	Default
Solar collector set temp	Min	5 °C~50 °C	10 °C
	Max	60 °C~105 °C	95 °C
DHW set temp	Max	20 °C~90 °C	80 °C
	Temp On	3 °C~40 °C	8 °C
TH on/off Variable, solar	Temp Off	1 °C~20 °C	2 °C
	Boost Heater	Enable/Disable	Enable
Solar pump flush schedule	On/OFF	On/Off	On
	Start Hour, Start Minute	00:00~24:00	6:00
	End Hour, End Minute	00:00~24:00	18:00
Solar pump test run	Pump test Run	Start/Stop	Stop
Solar pump flush setting	Oper.Cycle	30 min~120 min	60 min
	Oper.Time	1 min~10 min	1 min

**Zone**

It is the function to set the environment and check the operating status when using the zone module.

In the installer setting list, select the zone category, and press [OK] button to move to the detail screen.

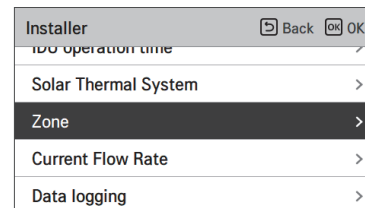
**<Zone setting>**

When using the zone module, it is the function to set the environment necessary for control such as the number of use and address setting.

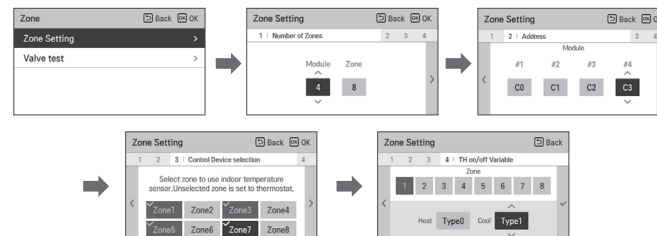

	Function	Value	Range
Step1	Number of Zones	Number of Modules	Not use, 1 ~ 4
		Number of Zones	Up to two zones can be used for one module.
Step2	Address	Address for each module	C0 ~ C3 *It can be set as many as the number of modules
Step3	Control device selection	Type selection for zone	Sensor / Thermostat
Step4	TH on/off variable	Heat	Type0 ~ Type3
		Cool	Type0 ~ Type3

**NOTE**

Th on/off variable can be set only when the control device selection is set to "Sensor" on the step 3.

**<Valve test>**

This function is provided to check if each valve works properly after installing / setting the zone module.



Value1	Value2	Description
Start / Stop	Open / Close	When selecting zone, the status is "OPEN"

**NOTE**

If the test is not stopped after the start of valve test, the test is automatically terminated after 60 minutes.

**Current flow rate**

It is the function to check the current flow rate.

- In the installer setting list, select Current Flow Rate category, and press [OK] button to move to the detail screen. The current flow rate can be checked. (Range : 7 ~ 80 L/min)
- The function is not available for some products.

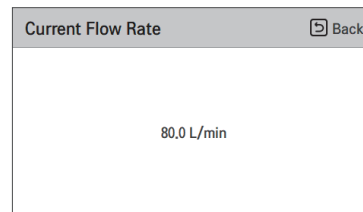
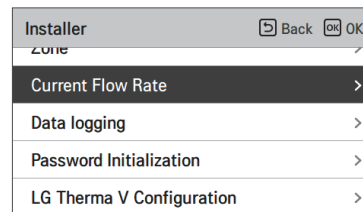

## Data logging

It is the function to set the operation reference value in Seasonal Auto mode.

- In the installer setting list, select Data logging category, and press [OK] button to move to the detail screen.

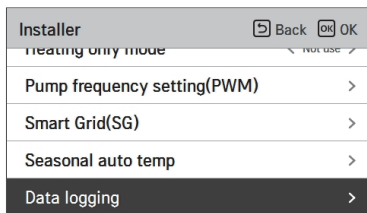

The screenshot shows the 'Data logging' detail screen with a table of logs. The table has columns for Date, Time, Oper., Settemp, and In/Out. The first row is highlighted in black.

Date	Time	Oper.	Settemp	In/Out
1970.01.01	00:10	Off	-	24° / 25°
1970.01.01	00:09	Off	-	24° / 25°
1970.01.01	00:09	Off	-	24° / 25°
1970.01.01	00:09	Off	-	24° / 25°
1970.01.01	00:09	Off	-	24° / 25°

### NOTE

Error history lookup range: 50

Error history information

Item: date, time, mode (including Off), set temperature, incoming temperature, outgoing temperature, room temperature, Hot water operation / stop, Hot water set temperature, Hot water temperature, Outdoor unit On / Off, Error code

Number of Display: Within 50

- Save criteria ▶

- ▶ Error occurred, released  
ON / OFF of outdoor unit operation

## Password Initialization

It is the function to initialize (0000) when you forgot the password set in the remote controller.

- In the installer setting list, select the password initialization setting category, and press [OK] button to move to the detail screen.
- When you press "initialization" button, a popup screen appears, and when you press "check" button, password initialization starts, and the user password is changed to 0000.

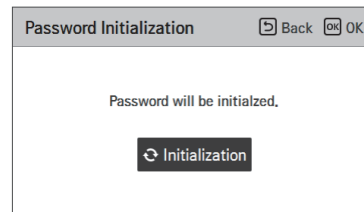
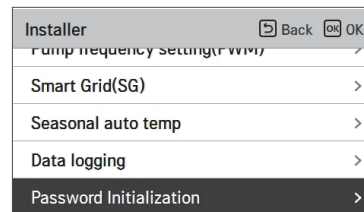

## RMC master/slave

This function is to set master / slave to use two remote controllers in one indoor unit.

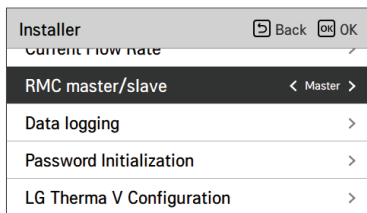

### NOTE

After completing the RMC master/slave setting, turn off the power of indoor unit, and turn on the power after 1 minutes.

## NOTICE

### OPEN SOURCE SOFTWARE NOTICE INFORMATION

To obtain the source code under GPL, LGPL, MPL, and other open source licenses, that is contained in this product, please visit <http://opensource.lge.com>. In addition to the source code, all referred license terms, warranty disclaimers and copyright notices are available for download. LG Electronics will also provide open source code to you on CD-ROM for a charge covering the cost of performing such distribution (such as the cost of media, shipping, and handling) upon email request to [opensource@lge.com](mailto:opensource@lge.com). This offer is valid for a period of three years after our last shipment of this product. This offer is valid to anyone in receipt of this information.

