



Scan the QR code to see the manual.



OWNER'S MANUAL

WATER PURIFIER



Before beginning installation, read these instructions carefully. This will simplify installation and ensure that the product is installed correctly and safely. Leave these instructions near the product after installation for future reference.

ENGLISH



MFL72049501
Rev.02_081624

www.lg.com

Copyright © 2023-2024 LG Electronics. All Rights Reserved

TABLE OF CONTENTS

This manual may contain images or content that may be different from the model you purchased.
This manual is subject to revision by the manufacturer.

SAFETY INSTRUCTIONS

- READ ALL INSTRUCTIONS BEFORE USE..... 3
- WARNING 3
- CAUTION 7
- CARING FOR THE ENVIRONMENT 7

INSTALLATION

- Before Installation 10
- Turning on the Power 10
- Final Installation Check 10

OPERATION

- Before Use 12
- Product Features 13
- Control Panel 13

MAINTENANCE

- Cleaning 15
- Replacing 16

TROUBLESHOOTING

- Before Calling for Service 18

APPENDIX

- Water Piping Diagram 20
- Product Information 21
- Warranty 22

SAFETY INSTRUCTIONS

READ ALL INSTRUCTIONS BEFORE USE

The following safety guidelines are intended to prevent unforeseen risks or damage from unsafe or incorrect operation of the appliance. The guidelines are separated into 'WARNING' and 'CAUTION' as described below.

Safety Messages



This symbol is displayed to indicate matters and operations that can cause risk. Read the part with this symbol carefully and follow the instructions in order to avoid risk.



WARNING

This indicates that the failure to follow the instructions can cause serious injury or death.



CAUTION

This indicates that the failure to follow the instructions can cause the minor injury or damage to the product.

WARNING

WARNING

- To reduce the risk of explosion, fire, death, electric shock, injury or scalding to persons when using this product, follow basic precautions, including the following:

Technical Safety

- This appliance is not intended for use by persons (including children) with reduced physical, sensory or mental capabilities, or lack of experience and knowledge, unless they have been given supervision or instruction concerning use of the appliance by a person

responsible for their safety. Children should be supervised to ensure that they do not play with the appliance.

- This appliance is intended to be used in household and similar applications only. It should not be used for commercial, or catering purposes, or in any mobile application such as a caravan or boat.
- If the power cord is damaged or the hole of the outlet socket is loose, do not use the power cord and contact an authorized service centre.
- Do not locate multiple portable outlet sockets or portable power supplies at the rear of the appliance.
- Securely plug the power plug in the outlet socket after completely removing any moisture and dust.
- Never unplug the appliance by pulling on the power cable. Always grip the power plug firmly and pull straight out from the outlet socket.
- Keep ventilation openings, in the appliance enclosure or in the built-in structure, clear of obstruction.
- Do not store explosive substances such as aerosol cans with a flammable propellant in this appliance.
- Do not tilt the appliance to pull or push it when transporting.
- When positioning the appliance, ensure the supply cord is not trapped or damaged.
- Do not spray water or inflammable substances (toothpaste, alcohol, thinner, benzene, flammable liquid, abrasive, etc.) over the interior or exterior of the appliance to clean it.
- Do not clean the appliance with brushes, cloths or sponges with rough surfaces or which are made of metallic material.
- Only qualified service personnel from LG Electronics service centre should disassemble, repair, or modify the appliance. Contact an LG Electronics customer information centre if you move and install the appliance in a different location.
- New hose-sets supplied with the appliance are to be used and that old hose-sets should not be reused.
- Connect the water pipe of the appliance to potable water only.

- Disconnect the power cord before cleaning the appliance interior or exterior.

Installation

- This appliance should only be transported by two or more people holding the appliance securely (applies only to stand water purifiers).
- Install the appliance on a firm and level floor/wall.
- Do not install the appliance in a damp and dusty place. Do not install or store the appliance in any outdoor area, or any area that is subject to weathering conditions such as direct sunlight, wind, rain, or temperatures below freezing.
- Do not place the appliance in direct sunlight or expose it to the heat from heating appliances such as stoves or heaters.
- Be careful not to expose the rear of the appliance when installing.
- Install the appliance in a place where is easy to unplug the power plug of the appliance.
- Never start up an appliance showing any signs of damage. If in doubt, consult your dealer.
- Do not connect a plug adapter or other accessories to the power plug.
- Do not modify or extend the power cable.
- Do not use an extension cord or double adapter.
- Do not plug the appliance into a multi socket adapter which does not have a power cable (mounted).
- Do not use a multi socket outlet which is not properly grounded (portable). In case of using a properly-grounded multi socket outlet (portable), use the multi socket outlet with the current capacity of the power cord rating or higher and use the multi socket outlet only for the appliance.
- The appliance should be connected to a dedicated power line which is separately fused.
- Do not plug the appliance into multiple outlet sockets, power boards, or an extension power cable.

- Dispose of all packaging materials (such as plastic bags and styrofoam) away from children. The packaging materials can cause suffocation.

Operation

- If water penetrates electrical parts of the appliance, disconnect power plug and contact an LG Electronics customer information centre.
- Unplug the power plug during a severe thunderstorm or lightening or when not in use for a long period of time.
- Do not touch the power plug or the appliance controls with wet hands.
- Do not bend the power cable excessively or place a heavy object on it.
- Immediately unplug the power plug and contact an LG Electronics customer information centre if you detect a strange sound, odour, or smoke coming from the appliance.
- Do not place hands or metallic objects inside the area emitting the cold air, cover or heat releasing grille on the back.
- Do not place heavy or fragile objects, containers filled with liquid, combustible substances, flammable objects (such as candles, lamps, etc.), or heating devices (such as stoves, heaters, etc.) on the appliance.
- Do not use flammable or combustible substances (ether, benzene, alcohol, chemical, LPG, combustible spray, insecticide, air freshener, cosmetics, etc.) near the appliance.
- If water is leaking from the inside of the appliance or water has collected near the appliance, close the water supply valve, unplug the power plug.
- Do not move the appliance while the appliance is plugged in.

CAUTION

CAUTION

- To reduce the risk of minor injury to persons, malfunction, or damage to the product or property when using this product, follow basic precautions, including the following:

Operation

- Replace the filter with a LG standard filter periodically according to the replacement period. Older filters can multiply bacteria or change the taste of the water. The filter replacement period varies according to the usage, place of usage, season, and water quality.
- Do not bend or pinch the water supply hose and drain hose.
- Do not allow pets, or any persons to hang from or climb on the appliance.
- Prevent animals from nibbling on the power cable or water hose.
- This feature is only available on some models. The tempered glass on the front side of the appliance can be damaged by an impact. If it is broken, do not touch it with hands.

Maintenance

- This feature is only available on some models. Do not clean glass covers with warm water when they are cold. They may shatter if exposed to sudden temperature changes.

CARING FOR THE ENVIRONMENT

Disposal of Your Old Appliance (as per e-waste Rules)



1. When this crossed out wheeled bin symbol is depicted on the product and its operator's manual, it means the product is covered by E-Waste Management Rules India published by MoEF & CC, Govt. of India and are meant to be recycled, dismantled, refurbished or disposed off.

2. Do's

- a. The product is required to be handed over only to the authorized recycler for disposal.
- b. Keep the product in isolated area, after it becomes non-functional/unreparable so as to prevent its accidental breakage.

Don'ts

- a. The product should not be opened by the user himself/herself, but only by authorized service personnel.
- b. The product is not meant for re-sale to any unauthorized agencies/scrap dealer/kabariwalah.
- c. The product is not meant for mixing into household waste stream.
- d. Do not keep any replaced spare part(s) from the product in exposed area.

3. Any disposal through unauthorized agencies/person will attract action under Environment (Protection) Act 1986.

4. This product is complied with the requirement of Hazardous Substances as specified under E-Waste Management Rules India published by MoEF & CC, Govt. of India.

5. To locate a nearest collection centre or call for pick-up (limited area only) for disposal of this appliance, please contact No. 08069379999, Toll Free No. 1800-315-9999 for details. All collection centre and pick up facilities are done by third parties with LG Electronics India Pvt. Ltd. Merely as a facilitator. For more detailed information, please visit : <http://www.lg.com/in>.

अपने पुराने उपकरण का निपटान (ई- अपशिष्ट नियमों के अनुसार)



1. जब इस काटे गए पहिये वाले बिन का चिह्न किसी उपकरण और इसके ऑपरेटर और उसके ऑपरेटर की पुस्तिका के साथ संलग्न होता है, तो इसका मतलब है कि इसे "ई-अपशिष्ट" (प्रबंधन और हथालन) नियम के अंतर्गत सम्मिलित किया गया है और इसके पुनर्नवीनीकरण, नवीनीकरण, विघटन और निपटान के लिए बनाया गया है। MoEF & CC भारत सरकार द्वारा प्रकाशित (भारतीय "ई- अपशिष्ट" (प्रबंधन और हथालन))

2. करें

- क. उपकरण को सिर्फ अधिकृत पुनः नवीनीकरणकर्ता को ही निपटारन करने हेतु हस्तांतरित करें। ख. जब उपकरण कार्यरत ना हो, इसे अलग क्षेत्र में रखें ताकि उपकरण से होने वाली दुर्घटनाओं से बचा जा सके।
ना करें
- क. इस उपकरण को स्वयं उपयोगकर्ता द्वारा नहीं खोला जाना चाहिए, बल्कि केवल अधिकृत सेवा कर्मियों द्वारा ही खोला जाना चाहिए।
- ख. इस उपकरण को पुनः बिक्री के लिए किसी भी अनधिकृत संस्था /भंगार वाला /कबाड़ीवाला को ना दे।
- ग. इस उपकरण को किसी घरेलू अपशिष्ट सामान के साथ मिलाकर ना रखें।
- घ. उपकरण के बदले हुए या आंतरिक पुरजो को खुले क्षेत्र में न रखें।
- 3. यदि किसी अनधिकृत विभाग या व्यक्ति के द्वारा निपटारन किया जाता है तो यह पर्यावरण (सुरक्षा) अधिनियम 1986 के अंतर्गत आता है।
- 4. यह उत्पाद ई- अपशिष्ट (प्रबंधन और हथालन) नियम के तहत निर्दिष्ट खतरनाक पदार्थों की आवश्यकता का पालन करता है।
MoEF & CC, भारत सरकार द्वारा प्रकाशित (भारतीय "ई- अपशिष्ट" (प्रबंधन और हथालन))
- 5. उपरोक्त पदार्थों के निपटारन के लिए नजदीकी निपटारन संस्थान (संकीर्ण क्षेत्र) में कॉल करें। अधिक जानकारी के लिए हमारे नंबर **08069379999**, टोल फ्री नंबर **1800-315-9999** पर पर कॉल करें। सभी संग्रहण केंद्र व पिक-अप की सुविधाएं किसी थर्ड -पार्टी जो "LG Electronics India Pvt. Ltd." को अपनी सेवाएं प्रदान कर रही हों से करवाएं।
अधिक जानकारी के लिए, कृपया देखें वेब साइट : <http://www.lg.com/in>

INSTALLATION

Before Installation

Notes for Installation

- Do not lean the appliance more than 30°. Doing so can cause malfunctions.
- Keep a distance of 10 cm from front and sides of the product.
- If you do not use the appliance for a while due to moving, etc., store it in an environment where water does not freeze.
 - The appliance may malfunction due to freezing.
- Install on a hard and level floor/wall.
 - If the floor/wall of the installation site is uneven, vibration or noise may occur, and the appliance may fall over and cause injury.
- Places where installation should be avoided for hygienic management of water purifiers and prevention of condensation.
 - Outdoors or in direct sunlight
 - A place close to the toilet
 - In front of air conditioner/heater
 - Other places with high humidity or temperature
- Height between immediate water reservoir tank to water purifier inlet should be more than 4 meter for effective working of the product.
- For optimum performance of product, installation condition should be ≤ 250 mg/L TDS, hardness ≤ 125 mg/L and turbidity ≤ 5 NTU.

NOTE

- All models can only be installed with water supply from overhead storage tank. No other water supply should be used for installation of these models.
-

Ambient Temperature

- The appliance is designed to operate within a limited range of ambient temperatures, depending on the climate zone.
Install the appliance inside with a surrounding temperature of over 5 °C and less than 43 °C.

Turning on the Power

Connecting the Appliance

After installing the appliance, connect the power plug into the outlet socket.

NOTE

- Before moving and discarding the appliance, disconnect the plug from the socket outlet.
-

Final Installation Check

Testing the Appliance

- 1 Make sure that hoses are connected properly.
- 2 After installation, dispense water for the first time when water tank is full. Same process is to be followed after every filter change or digital sterilization. Appropriate time taken to fill the tank to the fullest is 1 hour, depending on water pressure, temperature, etc.
 - Water may remain inside the water filtration system due to the inspection process carried out while manufacturing the appliance.

NOTE

- Do not connect the water supply pipe of the appliance to the hot water pipe, and connect it only to the cold water pipe.

- When cutting the tube, cut it vertically to prevent water leakage.

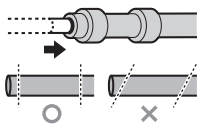

OPERATION

Before Use

General Notes

- If the appliance is not used for a long period, dispense the stored water from water purifier tank. If water has been left for a long period, bacteria can be generated and water taste can be changed.
- When you fill the cup with water, place it close to the water tap. Water may splash out of the cup and fall to the floor.
- Open the water supply valve. The appliance operates normally when water is supplied properly at a consistent pressure that is within the operating requirement.
- It is very important to replace the filter periodically in order to drink clean water. If an expired filter is used, the water taste may be changed and the filtration function may be degraded.
- Do not use filtered water to replace water in a humidifier or fishbowl. Leaving filtered water as it is for a long period of time may multiply the bacteria.
- Use the appliance only after closing the appliance cover completely. Otherwise, insects or other foreign substances may get in.

WARNING

- If the product will not be used for 2 or more days, unplug the power cord and close water supply valve before leaving premises and drain the water inside of water filtration system including tank completely before consumption of water.
-

NOTE

- All models of water purifier comes with a unique flow sensor which turns on only if there is running water supply to water purifier.
 - If no/lower water supply than specified limit is available, then water purifier will stop for 15 minutes and later, runs again for few seconds to check water supply.

- If water supply is detected, then water purifier will work normally otherwise it will repeat to check cycle again.
 - If water supply is available and you want to start water purifier immediately, must turn off the power supply and wait until the display gets turned off, and turn on the power again.
-

UV Sterilization

This feature is only available on some models.

UV Sterilization uses UV light to keep the water clean.

- **UV Sterilization** runs automatically for 75 minutes in every 6 hours. This function will momentarily stop each time when tank cover is opened if it is in operation and will resume after tank cover is closed.

Suggestion for Energy Saving

- If the appliance is not used for a long period, drain the remaining water completely and unplug the power plug.

Product Features

The appearance or components of the appliance may differ from model to model.

Exterior

Front and Rear

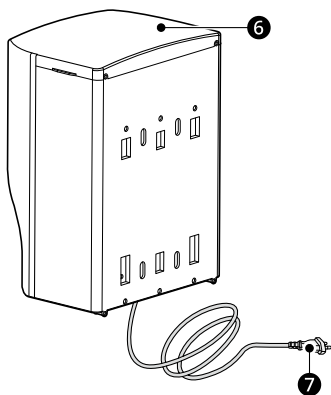
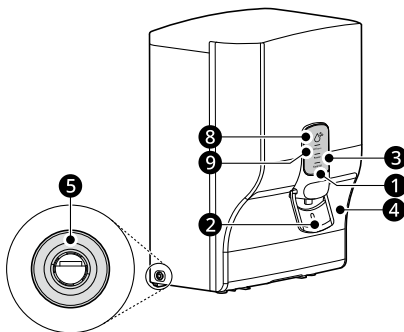

- ① Tank Full Indicator
- ② Touch Lever
- ③ Power Indicator
- ④ Filter Cover
- ⑤ Water Supply Hose
- ⑥ Top Cover
- ⑦ Power Cord
- ⑧ Filter Change Indicator*¹

⑨ UV Sterilizing Indicator

*1 This feature is applicable only for out sediment filter.

Accessories

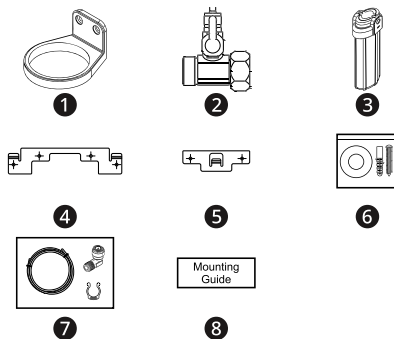

- ① Mounting Bracket
- ② Adaptor
- ③ Out Sediment Filter
- ④ Upper Mounting Plate (1 EA)
- ⑤ Lower Mounting Plate (1 EA)
- ⑥ Screw Kit
 - Screw (6 EA)
 - Anchor (6 EA)
 - Teflon Tape (1 roll)
- ⑦ Hose Assembly
 - Hose (1 EA)
 - Connector (2 EA)
 - Locker (2 EA)
- ⑧ Mounting Guide

Control Panel

The actual control panel may differ from model to model.

Control Panel and Functions

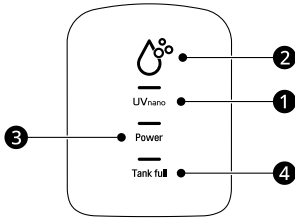

1 UV Sterilizing Indicator

Purified water is sterilized by the UV LED. When UV LED indicator will glow, it indicates that UV sterilization is **ON**.

When tank cover is open, UV LED will be automatically turned off for your safety.

NOTE

- The UV LED operates in any of the following 2 cases.
 - It operates for 75 minutes in every 6 hours.
 - It operates for 75 minutes after approximately 2 seconds when power is turned on following a power failure.
- Disclaimer:
UV nano is a compound word derived from the words UV and its unit, nanometre.

2 Filter Change Indicator

This feature is applicable for out sediment filter. When the color of indicator changes from blue to amber, this indicates that it is time for preventive maintenance service. Please call LG customer care for service.

3 Power Indicator

The Power LED glows to indicate **ON** condition of water purifier.

4 Tank Full Indicator

When the water storage tank gets filled up completely then tank full indicator will turn **ON**.

Using Purified Water

When you press the touch lever, purified water will come out.

If you wish to dispense continuously, lift the touch lever upward.

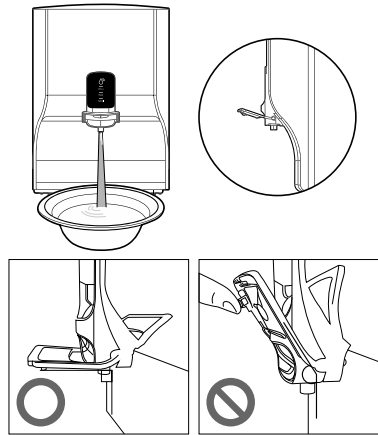

CAUTION

- Open this lever to 90 degrees only. Opening more than 90 degrees may cause it to malfunction/damage.

MAINTENANCE

Cleaning

Cleaning the Storage Tank

1 Close the water supply valve.

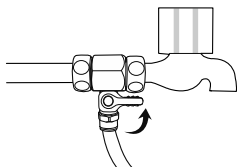

2 Drain water inside the storage tank completely using the drain hose and the water outlet.

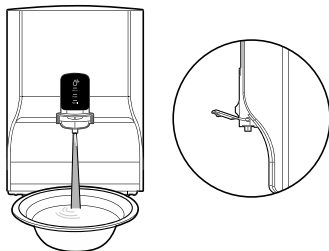

3 Unplug the power cord.

4 Open the top cover by lifting it upward, and then unlock the storage tank cover.

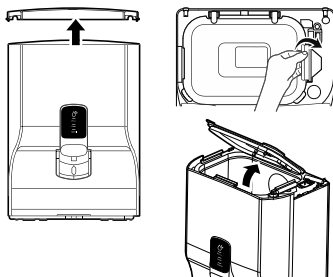

CAUTION

- Handle with care, sharp edges may cause injury.
- Do not put pressure or weight on tank cover, it may cause damage or injury.

5 Wipe the surface of the storage tank with soft clean cloth.

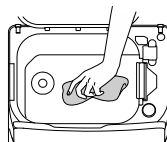

CAUTION

- Avoid touching any interconnecting part inside water tank. It may cause damage to the product.

6 Rinse the storage tank with purified water/ halogenated solution like chlorine. Drain completely once in four months.

WARNING

- Take care of water spattering, it may cause electric shock.

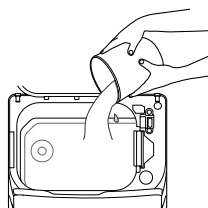

7 Insert and lock the storage tank cover.

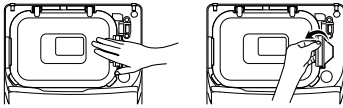

8 Close the top cover, plug in the power cord and open the water supply valve.

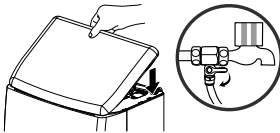

9 When tank is full, dispense water for the first time. Approximately time taken to fill the tank to fullest is 1 hour, depending on water pressure, temp etc.

⚠ WARNING

- Unplug the power cord when cleaning the storage tank. It may cause electric shock.

⚠ CAUTION

- Clean the tank by only using purified water. Do not use chemical except chlorine or detergent for cleaning the storage tank. Chemical or detergent will not be washed away completely, it can be harmful to the human body.

Cleaning the Water Outlet

Clean the water outlet periodically using a soft clean brush. Fur or foreign substances may accumulate in the water outlet.

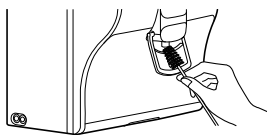

Replacing

Replacing the Water Filter

Process of Purification

Drinking water

- Step 1 ①
Out sediment filter
 - Remove big particles, rust stains, mud etc.
- Step 2 ②
Sedi + HMR carbon filter
 - Remove unseen dregs, other contamination and invisible fine particles.
 - Removes heavy metals*¹: arsenic, lead, cadmium, copper, chromium, iron and mercury.
- Step 3 ③
Ultra filtration filter
 - Removes only bacteria and fine particles substance.
- Step 4 ④
Virus clean⁺ filter
 - Removes Virus. (MS-2 Phage)*¹

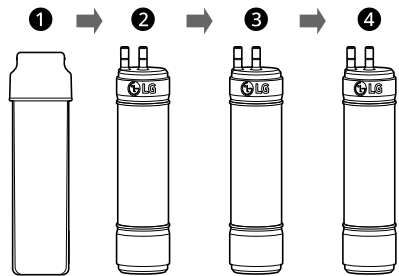

*1 This feature is as per 3rd party testing in accordance with applicable standards.

Filter Replacement Period

The filter replacement period refers to the period that the purification performance of the filter is maintained. And the replacement period is lesser in the case of a place with poor water quality or a large purification amount.

Filter name	Recommended purification amount (in litres)*1
Out sediment filter	3000
Sedi + HMR carbon filter	3000
Ultra filtration filter	6000
Virus clean+ filter	6000

- After installation, dispense water for the first time when water tank is full. Same process is to be followed after every filter change or digital sterilization. Approximate time taken to fill the tank to the fullest is 1 hour, depending on water pressure, temperature etc.
- There is no impact on TDS of water.

*1 This is as per LGEIL standard.

WARNING

- Filter replacement and /or AMC request can only be placed via calling LG customer care (refer last page).
- Warranty shall be void in case of use of counterfeit (duplicate) filters or replacement of filters from unauthorized sources.
- Using counterfeit filters or procuring filters from unauthorized sources may negatively impact or degrade product performance and product life. It may not be safe drinking water and may also impact user's health.
- LG shall not be responsible for any damage arising directly or indirectly out of any defect being noticed in the product due to usage of such counterfeit filters.

CAUTION

- Out sediment filter may get choked in abnormal turbidity (sand and mud) condition, it is suggested to switch **ON** water purifier after 1-2 hour of overhead tank filling so that sand/mud will get settled. Out sediment filter should be cleaned regularly to prevent choking in above condition for better performance.

NOTE

- If you wish to replace the filter, contact LG electronics customer care.
- After replacing the filter, check if there is a leak from the product.

TROUBLESHOOTING

Before Calling for Service

Water

Symptoms	Possible Cause & Solution
Water tastes strange.	Have you left the water purifier for a period of 2 or more days without using it? <ul style="list-style-type: none"> The taste of water may change as it ages. Use the water purifier after discharging the tank one time. In case issue persists please contact LG customer care service.
	Have you installed the appliance long ago or not changed filter for a long period? <ul style="list-style-type: none"> If the filter is not replaced regularly, the water quality of the appliance will deteriorate. Replace a new water filter.
	Input TDS of water may get increased from recommended value. <ul style="list-style-type: none"> Contact LG Electronics service centre.
Fine particles occur in the filtered water.	Did water bubbles form? <ul style="list-style-type: none"> Water bubbles may form in the draining process. It is safe for you to drink. If fine particles exist continuously after you receive water from the water purifier and several minutes have passed, cut off the tap water supply and power supply and contact LG customer care service.

Dispensing

Symptoms	Possible Cause & Solution
Water does not dispense.	Did you shut off the valve located at the connection to the water source? <ul style="list-style-type: none"> Open the valve.
	Did you unplug the power plug from the outlet socket? <ul style="list-style-type: none"> Plug the power plug into the outlet socket correctly.
	Did you miss the filter replacement period? <ul style="list-style-type: none"> Request for filter replacement.
	Does water not come out when you press the dispense lever? <ul style="list-style-type: none"> Contact LG customer care service.
The purification amount has reduced suddenly.	Is it time to replace the filter? <ul style="list-style-type: none"> Request for filter replacement.

Symptoms	Possible Cause & Solution
The purification amount has reduced suddenly.	<p>Is the water supply valve closed?</p> <ul style="list-style-type: none"> • Open the water supply valve.

Noises

Symptoms	Possible Cause & Solution
The appliance is noisy and generates abnormal sounds.	<p>Is the appliance installed on a weak floor or improperly levelled?</p> <ul style="list-style-type: none"> • Install the appliance on a solid and flat area.
	<p>Does the rear of the appliance touch the wall?</p> <ul style="list-style-type: none"> • Adjust the installation position to allow enough clearance around the appliance.
	<p>Is there an object on top of the appliance?</p> <ul style="list-style-type: none"> • Remove the object on top of the appliance.
	<p>Is the water pressure high?</p> <ul style="list-style-type: none"> • You may hear a valve operating sound when starting or ending water dispense. This is normal.

APPENDIX

Water Piping Diagram

Water Piping Diagram

WW120NNC

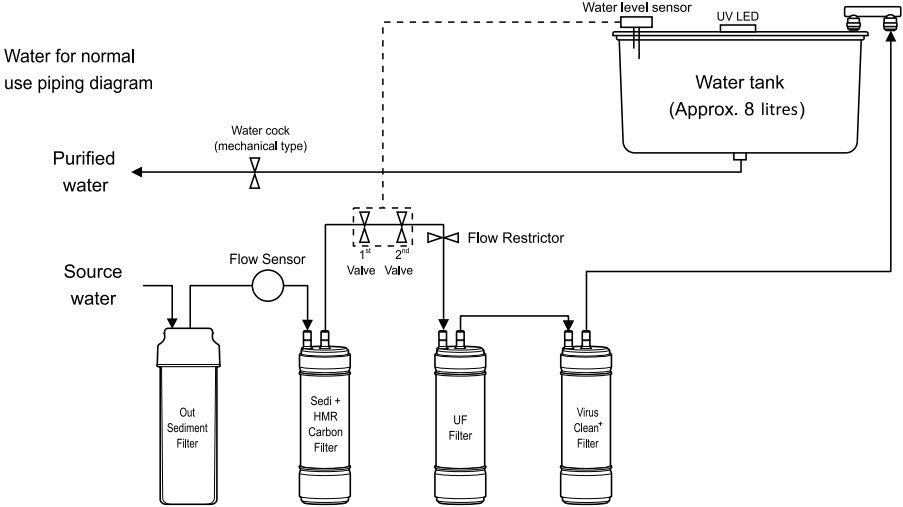

Electrolysis Sterilizing Care
Water piping diagram

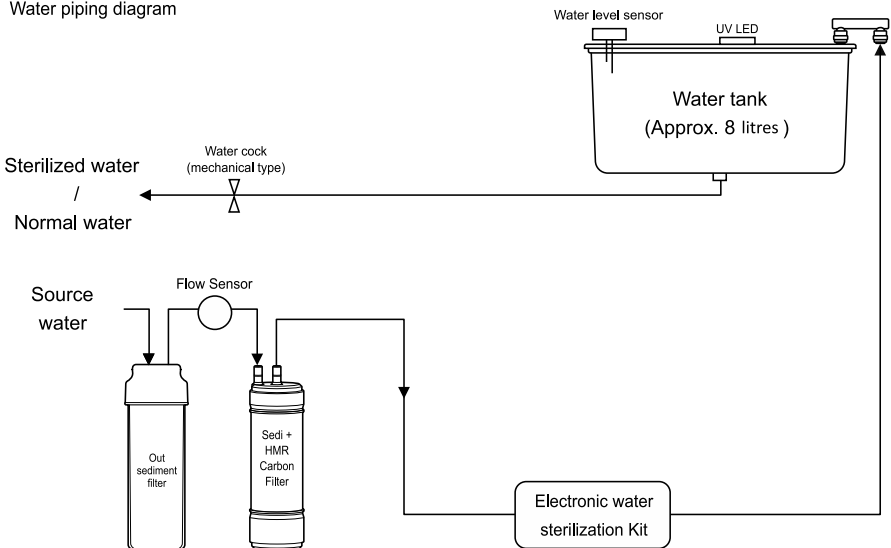

Product Information

Product Specifications

Model Name		WW120NNC
Purification method		Ultra filtration + Virus clean ⁺
UV sterilization		Yes
Rated voltage		230 V~ 50 Hz
Power rating		Water purifying: 20 W
Volume of tank		Approx. 8 L
Filter material	Out sediment filter	Polypropylene module
	Sedi + HMR carbon filter	Polypropylene module + carbon Block
	Ultra filtration filter	Polysulfone
	Virus clean ⁺ filter	Carbon block + Cellulose + Polypropylene
Dimension		365 mm (W) x 283 mm (D) x 506 mm (H)
Net weight		7.5 kg
Installation water pressure limit		40 - 860 kPa (0.4 - 8.8 kgf/cm ²)
		Recommended input water quality
Total Dissolved Solids (TDS)		≤ 250 mg/L
Total hardness		≤ 125 mg/L
Turbidity		≤ 5 NTU

Warranty

Warranty and Service Information

Warranty

The Water Purifier (hereinafter referred as product) comes with 1 year warranty on all parts (except Plastic parts, Consumables, Loose Plastic Parts, Filters, RO Filter) and thereafter a 9 years additional warranty only on the stainless steel tank from the date of purchase on producing the tax paid invoice of the product provided always that the warranty card bears the rubber stamp, date and signature of our authorized dealer.

9 YEAR ADDITIONAL WARRANTY ON THE STAINLESS STEEL TANK

The 9 Year warranty on the Stainless Steel Tank will continue even after the expiry of 1 year period from the date of purchase. This warranty covers Stainless Steel Tank only. However the water tank should be used only for purpose as specified in the user manual. The company's obligation under this warranty shall be limited to repair or providing replacement of defective parts only under the warranty period. During the additional warranty period, it does not cover parts such as PCB/Controller assembly, solenoid valve, flow sensor, UV LED lamp, water level sensor, filters, consumable parts, etc. The standard visiting charges will be applicable within municipal limit of town where LG Electronics India Pvt. Ltd. (LGEIL) has its Authorized Service Centre, Service Outside municipal limit will attract to and fro travelling, other incidental expense in addition to standard visiting charges, as per the prevailing from time to time. During the additional warranty period only the parts replaced or repaired shall be free of costs, but service charges shall always be payable by the customer.

TERMS & CONDITIONS

1. The warranty is confined to the first purchaser of the Water Purifier only & is non-transferable.
2. Repairs & replacements will be carried out through the Authorized Service Centres of LG Electronics India Pvt. Ltd. (hereinafter referred as LG or LGEIL). Customer may place their service call through the LG customer care or through the dealer from whom the product has been purchased. In case the customer shifts the place of residence during warranty period, it is advised to contact our helpline.
3. Repair under warranty shall be carried out by an authorized service personnel only. The details of centralized helplines are attached.
4. For units installed beyond municipal limits of the jurisdiction of company's Authorized Service Centre, it is responsibility of the purchaser to contact the nearest authorized service centre and bring the unit to the authorized service at its own cost and risk. All expense incurred in collecting the units or parts thereof from the company's authorized service centre, as well as expenses incurred with deputing of service personnel/ technician toward conveyance and other incidentals etc. will be borne by the customer. Local charges for transportation and handling charges may vary from location to location. Customers are advised to verify before. In case the customer desires to bring the unit on its own to the Authorized Service Centre, the same shall be at its own risks & consequences.
5. The concerned authorized service centre will advise the customer whether to effect the repairs at site or at the authorized service centre.
6. Call registered with the centralized helpline/Authorized service centre, wherein only cleaning of the unit/parts in the unit due to dust accumulation on portions of the units are not to be considered as defects.
7. In case of repairs or replacement of any part/s of the unit, this warranty will thereafter continue and remain in force only for the unexpired period of the warranty. LGEIL may use parts that are new or refurbished and equivalent to new in performance and reliability. Replacement of parts would be purely at the discretion of LGEIL alone. In case the replacement of the entire unit is being made, (subject to the sole discretion of LGEIL), the same model shall be replaced and in the event such model has been discontinued, it shall be replaced with the model price equivalent at the time of purchase.

8. In case of any damage to the product/customer abuse/repairs by un-authorized personnel's/misuse detected/ by the Authorized Service Centre personnel, the warranty conditions are not applicable and repairs will be done subject to availability of parts and on a chargeable basis only.
9. This warranty shall not cover any consequential or resulting liability, damage or loss to property or life arising directly or indirectly out of any defect being noticed in the equipment during warranty period of the Water Purifier. The company's obligation under this warranty shall be limited to repair or providing replacement of defective parts only under the warranty period.
10. The company or its Authorized Service Centre reserves the right to retain any part's or component replaced its discretion, in the event of defect being noticed in the equipment during warranty period.
11. While the company will make every effort to carry out repairs at the earliest, it however is made expressly clear that the company is under no obligation to do so in a specified period of time.
12. Warranty does not cover accessories external to the equipment supplied by the dealer.
13. In the event of any unforeseen circumstance, and spares not being available, the company's prevailing depreciation rules will be binding on the purchaser to accept as a commercial solution in lieu of repairs.
14. If any coloured internal or external components are replaced, there will be commitment to ensure that the shades match with the original or other components. The replaced shades, patterns, tints may vary from the customer's unit due to continuous usage of the unit. Any matching components changed at customer's request will be chargeable basis except the component which actually needed.
15. Free Installation or Demo of the product, can be availed only once & within 3 months from the date of purchase.
16. Any extended warranty offered by LGEIL has to be supported by relevant proof.
17. During 1st year warranty LGEIL recommend hygiene maintenance, provides 1 free scheduled visit depending upon model for service of the product, for which customer has to connect LG customer care or to confirm in case call received from LGEIL.
18. Warranty shall expire after the warranty period as mentioned above even if the Water Purifier may not be in use for any time during the warranty period for any reason.
19. Only courts in state of Delhi and places where LGEIL has its branch office shall have the jurisdiction for settling any claims, disputes arising under the warranty.

Warranty is not applicable in any of the following cases :

1. The warranty card is not completed properly at the time of purchase.
2. The completed warranty card is not presented to authorized service personnel at the time of service of the product.
3. The product is not operated according to instructions given in the Operating Instruction Booklet/ Owner's Manual.
4. The product is used for commercial purposes.
5. The input TDS of source water is more than the specifications as mentioned in the owner's manual.
6. The product has failed under certain conditions like water logging, flood, fire, misuse etc.
7. Defects/malfunction are caused by improper or reckless use, which shall be determined by the company personnel.
8. Any repair work is carried out by persons other than authorized service personnel.
9. Defect/malfunction are caused which are beyond control like lightening, abnormal voltage, Acts of God, virus etc.
10. Defects/malfunction caused while in transit to service centre or purchaser's residence.
11. Defects caused by rodents bite or by pests and vermin ants/Insects/animals/birds etc.
12. The serial number is deleted, defected or altered.
13. Damage is caused to the product or any part/s due to transportation or shifting.
14. Any accessory external to the equipment are supplied by dealer or LG.

15. Any issue is caused by usage of 3rd party product like voltage stabilizer, power outlet socket, MCB, extension board etc.

CUSTOMER'S COPY

CUSTOMER'S COPY

MODEL No. :

DATE OF PURCHASE :

UNIT SERIAL No. :

CUSTOMER'S NAME & ADDRESS _____ _____ TEL. _____

DEALER'S NAME & ADDRESS _____ _____ TEL. _____

Customer's Signature

Dealer's Signature

Memo

Memo

Memo



LG Electronics India Pvt. Ltd.

Phone	08069379999 1800 315 9999 [Toll Free]
WhatsApp No.	9711709999
Mobile Application	'LG Service India Mobile App' available at Google Play
SNS	www.facebook.com/LGIndiaPage www.twitter.com/LGIndia
Address	Regd. Office: LG Electronics India Pvt. Ltd., A-24/6 Mohan Cooperative Industrial Estate, Mathura Road, New Delhi-110044 CIN No. U32107DL1997PTC220109

24 hours, 7 days a week (except National Holidays)