

INSTALLATION MANUAL

AIR-TO-WATER HEAT PUMP

Please read this installation manual completely before installing the product. Installation work must be performed in accordance with the national wiring standards by authorized personnel only. Please retain this installation manual for future reference after reading it thoroughly.

THERMA V™

Original instruction



MFL68681818
Rev.07_032624

www.lg.com

Copyright © 2020 - 2024 LG Electronics Inc. All Rights Reserved.

PORTUGUÊS

ENGLISH

MAGYAR

ITALIANO

БЪЛГАРСКИ

ESPAÑOL

SRPSKI

FRANÇAIS

HRVATSKI

DEUTSCH

SLOVENŠČINA

EMHNİKA

DANSK

ČEŠTINA

NEDERLANDS

POLSKI

LIMBA ROMÂNĂ

TABLE OF CONTENTS

7 PREFACE

[Chapter 1]

8 SAFETY INSTRUCTIONS

[Chapter 2]

16 INSTALLATION PART

[Chapter 3]

19 GENERAL INFORMATION

- 19 Model Information
- 22 Model name and related information
- 22 How to find additional model information
- 23 Parts and Dimensions
- 29 Control Parts
- 31 Control Panel
- 32 Typical Installation Example
- 35 Cycle Diagram (For Split IWT)
- 36 Cycle Diagram (For Hydrosplit IWT)
- 37 Piping Diagram (For Split IWT)
- 38 Piping Diagram (For Hydrosplit IWT)
- 39 System planning and preparation

[Chapter 4]

40 INSTALLATION OF OUTDOOR UNIT

- 40 Conditions where Outdoor Unit is Installed
- 40 Drill a Hole in the Wall (For Split)
- 41 Transporting the Unit
- 42 Installation at Seaside
- 43 Seasonal Wind and Cautions in Winter

[Chapter 5]**44 INSTALLATION OF INDOOR UNIT**

- 44 Conditions where Indoor Unit is Installed
- 45 Transporting the Unit
- 46 Connecting Condensate drainage
- 46 Front Panel Removal
- 47 Floor area requirement : Indoor unit (For Split IWT)
- 48 Ventilation requirements
- 51 Electrical Wiring

[Chapter 6]**55 PIPING AND WIRING FOR OUTDOOR UNIT**

- 55 Refrigerant Piping (For Split IWT)
- 59 Water Piping (For Hydrosplit IWT)
- 60 Wiring Procedure for Power Cable and Connecting Cable
- 63 Finalizing (For Split)
- 64 Finalizing (For Hydrosplit)
- 65 Leakage test and Evacuation (For Split IWT)
- 67 Electrical Wiring

[Chapter 7]**72 HYDRAULIC CONNECTION FOR INDOOR UNIT**

- 72 General Considerations
- 74 Connection to the Domestic hot water system
- 77 Connection to the Heating system
- 79 Water Charging
- 80 Water pump Capacity
- 80 Pressure Drop
- 81 Performance curve
- 83 Water Quality
- 83 Frost protection

[Chapter 8]**84 ACCESSORIES INSTALLATION**

- 85 Before Installation
- 86 Domestic hot water expansion vessel – integrated into the unit
- 87 Buffer tank – integrated into the unit
- 90 Thermostat
- 94 2nd Circuit
- 99 3rd Party Boiler
- 100 3rd Party Controller
- 101 Meter Interface
- 102 Central Controller
- 105 Dry Contact
- 108 External Controller - Setting up programmable digital input operation
- 109 Remote Temperature Sensor
- 112 External pump
- 113 Wi-fi Modem
- 115 Smart Grid (For Split IWT)
- 116 Energy State (For Hydrosplit IWT)
- 117 Digital Input for energy saving (ESS, Smart Grid)(For Hydrosplit IWT)
- 118 2Way Valve
- 119 Final check

[Chapter 9]**120 CONFIGURATION**

- 120 DIP Switch Setting (For Split IWT)
- 124 DIP Switch Setting (For Hydrosplit IWT)

130 SERVICE SETTING

- 130 How to enter service setting
- 130 Service setting
- 131 Service contact
- 132 Model information
- 133 RMC version information
- 134 Open source license

135 INSTALLER SETTING

- 135 How to enter installer setting
- 136 Installer setting (For Split IWT)
- 139 Installer setting (For Hydrosplit IWT)
- 142 Select Temperature Sensor
- 143 Use Heating Tank Heater
- 144 Mixing circuit (For Split IWT)
- 145 Mixing Circuit (For Hydrosplit IWT)
- 148 Use External Pump (For Split IWT)
- 149 Use External Pump (For Hydrosplit IWT)
- 150 RMC master/slave
- 151 LG Therma V Configuration
- 152 Forced operation
- 153 Pump Capacity (For Split IWT)
- 154 Pump Prerun/Overrun
- 155 Water Flow Control (For Hydrosplit IWT)
- 156 Password Reset
- 157 Heating temp. setting
- 158 Air heating set temp.
- 159 Water heating set temp
- 160 TH on/off Variable, heating air (For Split IWT)
- 161 TH on/off Variable, heating water (For Split IWT)
- 162 Hysteresis Heating Water (For Hydrosplit IWT)
- 163 Hysteresis Room Air(Heating) (For Hydrosplit IWT)
- 164 Pump setting in heating
- 165 Heater on temperature
- 166 Screed drying
- 168 Cooling temp. setting
- 169 Air cooling set temp.
- 170 Water cooling set temp
- 171 Water supply off temp. during cooling
- 173 TH on/off Variable, cooling air (For Split IWT)
- 174 TH on/off Variable, cooling water (For Split IWT)
- 175 Hysteresis Cooling Water (For Hydrosplit IWT)
- 176 Hysteresis Room Air(Cooling) (For Hydrosplit IWT)
- 177 Pump setting in cooling
- 178 Seasonal auto temp. (For Split IWT)

180	Seasonal auto temp. (For Hydrosplit IWT)
182	DHW set temp
183	Tank disinfection setting 1, 2
184	Tank setting 1
185	Tank setting 2
187	DHW time setting
189	Pump test run
190	Frost Protection Temp.
192	Dry Contact Mode
193	Central Control Address
194	CN_CC
195	Smart Grid (SG) (For Split IWT)
196	Power Supply Blockage (Smart Grid) (For Split IWT)
197	Modbus Address
198	Modbus gateway memory map (For Hydrosplit IWT)
201	CN_EXT
202	3rd Party Boiler
203	Meter Interface
204	Energy state (For Hydrosplit IWT)
206	Thermostat control type (For Hydrosplit IWT)
207	Pump operation time
208	IDU operation time
209	Current flow rate
210	Data logging

[Chapter 10]

211 COMMISSIONING

211	Check List before Starting Operation
212	Starting Operation
213	Starting Operation flow chart
213	Airborne Noise Emission
214	Vacuum & Charge of Refrigerant
217	Decommissioning and Recycling
219	Replacing magnesium anode
220	Troubleshooting
225	Reset of the thermal protection of the electrical heater
226	Open Source Software Notice Information

PREFACE





This installation manual is to present information and guide about understanding, installing, and checking **THERMAV**.

Your careful reading before installation is highly appreciated to make no mistake and to prevent potential risks. The manual is divided into ten chapters. These chapters are classified according to installation procedure. See the table below to get summarized information.

Chapters	Contents
Chapter 1	<ul style="list-style-type: none"> • Warning and Caution concerned with safety. • This chapter is directly related with human safety. We strongly recommend reading this chapter carefully.
Chapter 2	<ul style="list-style-type: none"> • Items Inside product Box • Before starting installation, please make it sure that all parts are found inside the product box.
Chapter 3	<ul style="list-style-type: none"> • Fundamental knowledge about THERMAV. • Model identification, accessories information, cycle diagram, parts and dimensions, etc. • This chapter is important to understand THERMAV.
Chapter 4	<ul style="list-style-type: none"> • Installation about the outdoor unit. • Installation location, constraints on installation site, etc
Chapter 5	<ul style="list-style-type: none"> • Installation about the indoor unit. • Installation location, constraints on installation site, etc
Chapter 6	<ul style="list-style-type: none"> • How to perform piping and wiring at the outdoor unit. • Refrigerant pipe connection between the indoor unit and the outdoor unit. • Water pipe connection between the indoor unit and outdoor unit. • Electrical wiring at the outdoor unit.
Chapter 7	<ul style="list-style-type: none"> • How to perform piping (for water) and wiring at the indoor unit. • Water pipe connection between the indoor unit and pre-built under floor water loop pipe. • Electrical wiring at the indoor unit. • System set-up and configuration. • As many control parameters of THERMAV is adjustable by control panel, deep understanding about this chapter is required to secure the operation flexibility of THERMAV. • For more detailed information, please read the separate operation manual to use control panel and adjust control parameters.
Chapter 8	<ul style="list-style-type: none"> • Information about supported accessories • Specification, Constraints, and wiring are described. • Before purchasing accessories, please find supported specification to buy proper one.
Chapter 9	<ul style="list-style-type: none"> • Information about installation setting. • DIP switch, service, installer setting etc.
Chapter 10	<ul style="list-style-type: none"> • Check points before starting operation are explained. • Troubleshooting, maintenance, and error code list are presented to correct problems.

REMARK : ALL CONTENTS OF THIS MANUAL ARE SUBJECT TO CHANGE WITHOUT NOTICE. TO GET THE LATEST INFORMATION, PLEASE VISIT LG ELECTRONICS WEB SITE.

SAFETY INSTRUCTIONS

	<p>Read the precautions in this manual carefully before operating the unit.</p>		<p>This appliance is filled with flammable refrigerant (R32)</p>
	<p>This symbol indicates that the Operation Manual should be read carefully.</p>		<p>This symbol indicates that a service personnel should be handling this equipment with reference to the Installation Manual.</p>

The following safety guidelines are intended to prevent unforeseen risks or damage from unsafe or incorrect operation of the appliance. The guidelines are separated into 'WARNING' and 'CAUTION' as described below.

 This symbol is displayed to indicate matters and operations that can cause risk. Read the part with this symbol carefully and follow the instructions in order to avoid risk.

WARNING

This indicates that the failure to follow the instructions can cause serious injury or death.

CAUTION

This indicates that the failure to follow the instructions can cause the minor injury or damage to the product.

WARNING

Installation

- Do not use a defective or underrated circuit breaker. Use this appliance on a dedicated circuit.
 - There is risk of fire or electric shock.
- For electrical work, contact the dealer, seller, a qualified electrician, or an Authorized Service Center.
 - There is risk of fire or electric shock.

- Always ground the unit.
 - There is risk of fire or electric shock.
- Install the panel and the cover of control box securely.
 - There is risk of fire or electric shock.
- Always install a dedicated circuit and breaker.
 - Improper wiring or installation may cause fire or electric shock.
- Use the correctly rated breaker or fuse.
 - There is risk of fire or electric.
- Do not modify or extend the power cable.
 - There is risk of fire or electric shock.
- Do not install, remove, or reinstall the unit by yourself (customer).
 - There is risk of fire, electric shock, explosion, or injury
- For antifreeze, always contact the dealer or an authorized service center.
 - Almost the antifreeze is a toxic product.
- For installation, always contact the dealer or an authorized Service Center.
 - There is risk of fire, electric shock, explosion, or injury.
- Do not install the unit on a defective installation stand.
 - It may cause injury, accident, or damage to the unit.
- Be sure the installation area does not deteriorate with age.
 - If the base collapses, the unit could fall with it, causing property damage, unit failure, and personal injury.
- Do not install the water pipe system as Open loop type.
 - It may cause failure of unit.
- Use a vacuum pump or inert (nitrogen) gas when doing leakage test or purging air. Do not compress air or oxygen and do not use flammable gases.
 - There is the risk of death, injury, fire or explosion.
- Make sure the connected condition of connector in product after maintenance.
 - Otherwise, it may cause product damage.
- Do not touch leaked refrigerant directly.
 - There is risk of frostbite.

- Copper in contact with refrigerants shall be oxygen-free or deoxidized, for example Cu-DHP as specified in EN 12735-1 and EN 12735-2.
- Compliance with national gas regulations shall be observed.
- Refrigerant tubing shall be protected or enclosed to avoid damage.
- The installation of pipe-work shall be kept to a minimum.
- A brazed, welded, or mechanical connection shall be made before opening the valves to permit refrigerant to flow between the refrigerating system parts. A vacuum valve shall be provided to evacuate the interconnecting pipe and/or any uncharged refrigerating system part.
- Any person who is involved with working on or breaking into a refrigerant circuit should hold a current valid certificate from an industry-accredited assessment authority, which authorises their competence to handle refrigerants safely in accordance with an industry recognised assessment specification.
- Do not use means to accelerate the defrosting process or to clean, other than those recommended by the manufacturer.
- Do not pierce or burn.
- Be aware that refrigerants may not contain an odour.
- Dismantling the unit, treatment of the refrigerant oil and eventual parts should be done in accordance with local and national standards.
- Flexible refrigerant connectors (such as connecting lines between the indoor and outdoor unit) that may be displaced during normal operations shall be protected against mechanical damage.
- Pipe-work shall be protected from physical damage.
- Mechanical connections (mechanical connectors or flared joints) shall be accessible for maintenance purposes.

Operation

- Take care to ensure that power cable could not be pulled out or damaged during operation.
 - There is risk of fire or electric shock.

- Do not place anything on the power cable.
 - There is risk of fire or electric shock.
- Do not plug or unplug the power supply plug during operation.
 - There is risk of fire or electric shock.
- Do not touch (operate) the unit with wet hands.
 - There is risk of fire or electric shock.
- Do not place a heater or other appliances near the power cable.
 - There is risk of fire or electric shock.
- Do not allow water to run into electric parts.
 - There is risk of fire, failure of the unit, or electric shock.
- Do not store or use flammable gas or combustibles near the unit.
 - There is risk of fire or failure of unit.
- Do not use the unit in a tightly closed space for a long time.
 - It may cause damage to the unit.
- When flammable gas leaks, turn off the gas and open a window for ventilation before turning the unit on.
 - There is risk of explosion or fire.
- If strange sounds, or smell or smoke comes from unit, turn the breaker off or disconnect the power supply cable.
 - There is risk of electric shock or fire.
- Stop operation and close the window in storm or hurricane. If possible, remove the unit from the window before the hurricane arrives.
 - There is risk of property damage, failure of unit, or electric shock.
- Do not open the front cover of the unit while operation. (Do not touch the electrostatic filter, if the unit is so equipped.)
 - There is risk of physical injury, electric shock, or unit failure.
- Do not touch any electric part with wet hands. you should be power off before touching electric part.
 - There is risk of electric shock or fire.
- Do not touch refrigerant pipe and water pipe or any internal parts while the unit is operating or immediately after operation.
 - There is risk of burns or frostbite, personal injury.

- If you touch the pipe or internal parts, you should be wear protection or wait time to return to normal temperature.
 - Otherwise , it may cause burns or frostbite, personal injury.
- Turn the main power on 6 hours ago before the product starting operation.
 - Otherwise, it may cause compressor damage.
- Do not touch electric parts for 10 minutes after main power off.
 - There is risk of physical injury, electric shock.
- The inside heater of product may operate during stop mode. It is intended to protect the product.
- Be careful that some part of the control box are hot.
 - There is risk of physical injury or burns.
- When the unit is soaked (flooded or submerged), contact an Authorized Service Center.
 - There is risk of fire or electric shock.
- Be cautious that water could not be poured to the unit directly.
 - There is risk of fire, electric shock, or unit damage.
- Ventilate the unit from time to time when operating it together with a stove, etc.
 - There is risk of fire or electric shock.
- Turn the main power off when cleaning or maintaining the unit.
 - There is risk of electric shock.
- Take care to ensure that nobody could step on or fall onto the unit.
 - This could result in personal injury and unit damage.
- If the unit is not used for long time, we strongly recommend not to switch off the power supply to the unit.
 - There is risk of water freezing.
- The appliance shall be stored in a well-ventilated area where the room size corresponds to the room area as specified for operation.
- The appliance shall be stored in a room without continuously operating open flames (for example an operating gas appliance) and ignition sources (for example an operating electric heater).

- The appliance shall be stored so as to prevent mechanical damage from occurring.
- Servicing shall only be performed as recommended by the equipment manufacturer. Maintenance and repair requiring the assistance of other skilled personnel shall be carried out under the supervision of the person competent in the use of flammable refrigerants.)
- When mechanical connectors are reused indoors, sealing parts shall be renewed. When flared joints are reused indoors, the flare part shall be re-fabricated.
- Periodic(more than once/year) cleaning of the dust or salt particles stuck on the heat exchangers by using water.
- Keep any required ventilation openings clear of obstruction.

CAUTION

Installation

- Always check for gas (refrigerant) leakage after installation or repair of unit.
 - Low refrigerant levels may cause failure of unit.
- Keep level even when installing the unit.
 - To avoid vibration or water leakage.
- Use two or more people to lift and transport the unit.
 - Avoid personal injury.
- In order to avoid a hazard due to inadvertent resetting of the thermal cut-out, this appliance must not be supplied through an external switching device, such as a timer, or connected to a circuit that is regularly switched on and off by the utility.
- Do not install the unit in potentially explosive atmospheres.
- The water may drip from the discharge pipe of the pressure-relief device and that this pipe must be left open to the atmosphere.
- The pressure-relief device is to be operated regularly to remove lime deposits and to verify that it is not blocked.
- A discharge pipe connected to the pressure-relief device is to be installed in a continuously downward direction and in a frost-free environment.

Operation



- Do not use the unit for special purposes, such as preserving foods, works of art, etc.
 - There is risk of damage or loss of property.
- Use a soft cloth to clean. Do not use harsh detergents, solvents, etc.
 - There is risk of fire, electric shock, or damage to the plastic parts of the unit.
- Do not step on or put anything on the unit.
 - There is risk of personal injury and failure of unit.
- Use a firm stool or ladder when cleaning or maintaining the unit.
 - Be careful and avoid personal injury.
- Do not turn on the breaker or power under condition that front panel cabinet, top cover, control box cover are removed or opened.
 - Otherwise it may cause fire, electric shock, explosion or death.
- The appliance shall be disconnected from its power source during service and when replacing parts.
- Means for disconnection must be incorporated in the fixed wiring in accordance with the wiring rules.
- The Installation kit supplied with the appliance are to be used and that old Installation kit should not be reused.
- If the supply cord is damaged, it must be replaced by the manufacturer, its service agent or similarly qualified persons in order to avoid a hazard. Installation work must be performed in accordance with the national wiring standards by authorized personnel only.
- This equipment shall be provided with a supply conductor complying with the national regulation.
- The instructions for service to be done by specialized personnel, mandated by the manufacturer or the authorized representative may be supplied in only one Community language which the specialized personnel understand.



- This appliance is not intended for use by persons (including children) with reduced physical, sensory or mental capabilities or lack of experience and knowledge, unless they have been given supervision or instruction concerning use of the appliance by a person responsible for their safety. Children should be supervised to ensure that they do not play with the appliance.

INSTALLATION PART

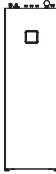

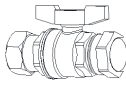
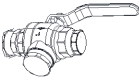

Thank you for choosing LG Electronics Air-to-Water Heat Pump **THERMAV.**
Before starting installation, please make it sure that all parts are found inside the product box.

(For Split IWT) INDOOR UNIT BOX

Item	Image	Quantity
Indoor Unit		1
Installation Manual		1
Owner's / Installation manual		1

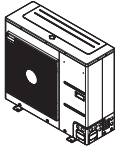

Item	Image	Quantity
Shut-off valve		1
Shut-off valve with integrated strainer		1
Gasket (G1")		2
Gasket (G3/4")		3



OUTDOOR UNIT BOX

Item	Image	Quantity
Outdoor Unit U36A Chassis		1
Damper		4
Drain Cap		2
Drain Nipple		1



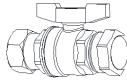
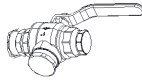

(For Hydrosplit IWT)

INDOOR UNIT BOX



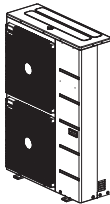







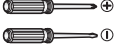

Item	Image	Quantity
Indoor Unit		1
Installation Manual		1
Owner's / Installation manual		1

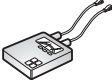
Item	Image	Quantity
Shut-off valve		1
Shut-off valve with integrated strainer		1
Gasket (G1")		4
Gasket (G3/4")		3

OUTDOOR UNIT BOX

Item	Image	Quantity
Outdoor Unit U60A Chassis		1
Drain Cap		4
Drain Nipple		1
Strainer		1
Damper		4

INSTALLATION TOOLS

Figure	Name	Figure	Name
	Screw driver		Ohmmeter
	Electric drill		Hexagonal wrench
	Measuring tape, Knife		Ammeter
	Hole core drill		Leak detector
	Spanner		Thermometer, Horizontal meter
	Torque wrench		Flaring tool set
	Manifold Gauge		Vacuum Pump

GENERAL INFORMATION

With advanced inverter technology, **THERMAV** is suitable for applications like under floor heating, under floor cooling, and hot water generation. By Interfacing to various accessories user can customize the range of the application.

In this chapter, general information of **THERMAV** is presented to identify the installation procedure. Before beginning installation, read this chapter carefully and find helpful information on installation.

Model Information

Factory Model Name

Outdoor unit (For Split IWT)

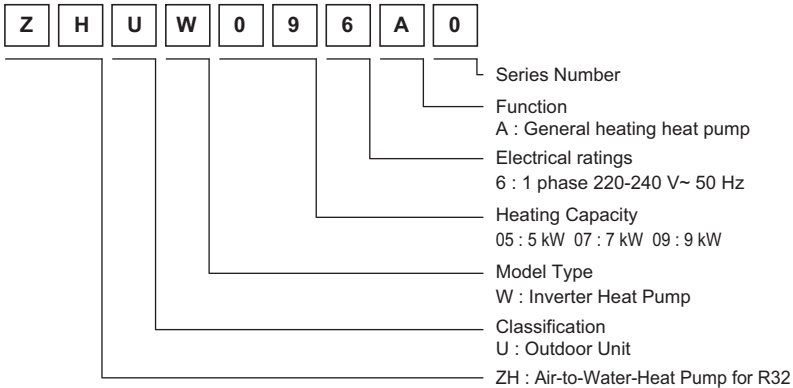

Outdoor unit (For Hydrosplit IWT)

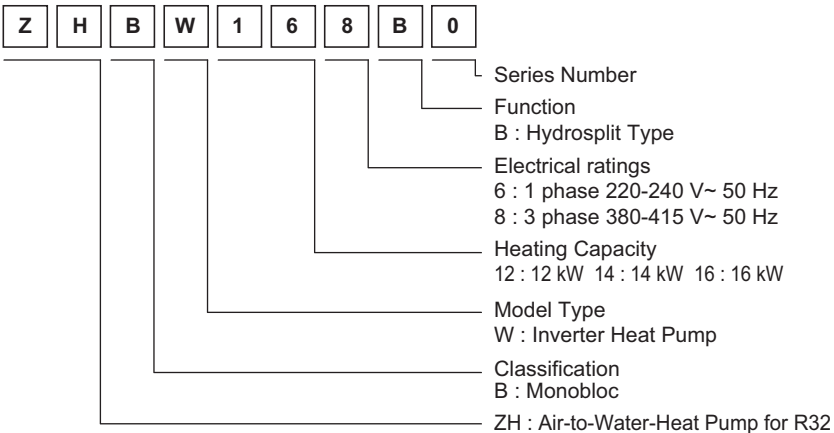

Indoor unit

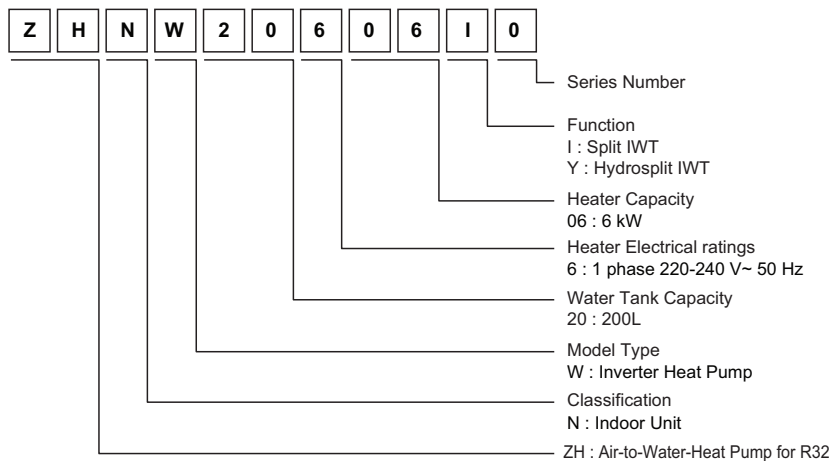

- IWT : Integrated water tank Indoor unit

Buyer Model Name

Outdoor unit (For Split IWT)

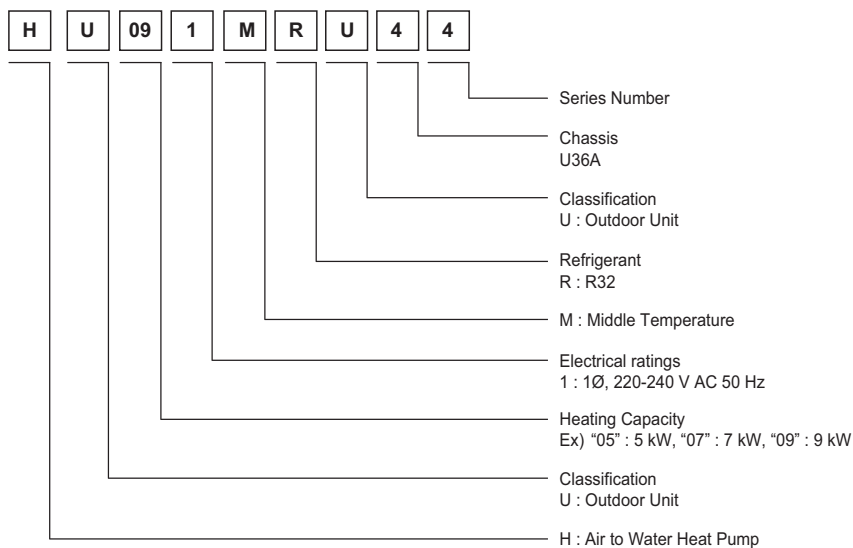

Outdoor unit (For Hydrosplit IWT)

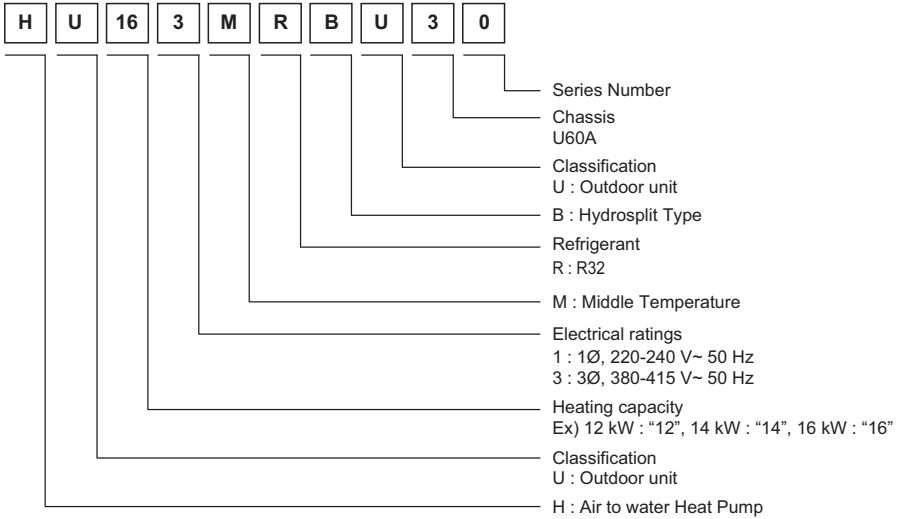

Indoor unit

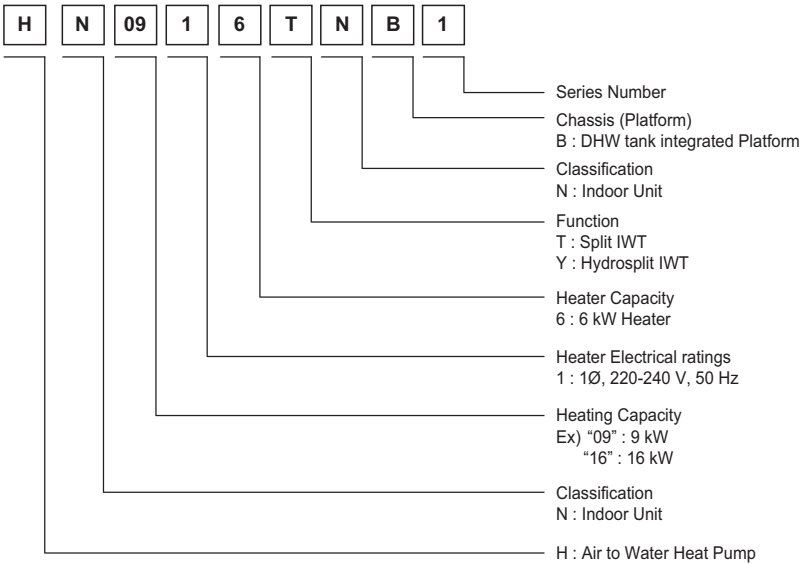

- IWT : Integrated water tank Indoor unit
- DHW : Domestic hot water

Model name and related information

Type	Refrigerant	Model Name			Built-In Electric Heater(kW)	Capacity		Power Source (Unit)						
		Outdoor Unit		Indoor Unit		Heating (kW)* ¹	Cooling (kW)* ²							
		Phase (Ø)	Capacity (kW)	Tank Capacity (L)										
Split	R32	1	5	200	1Ø 2 (2) 1Ø 4 (2+2) 3Ø 6 (2+2+2)	5.5	5.5	220-240 V 50 Hz						
			7			7.0	7.0							
			9			9.0	9.0							
Hydrosplit		1	12			12	200	1Ø 2 (2) 1Ø 4 (2+2) 3Ø 6 (2+2+2)	12.0	12.0	220-240 V 50 Hz			
						14			14.0	14.0				
						16			16.0	16.0				
			3			12			12	200	1Ø 2 (2) 1Ø 4 (2+2) 3Ø 6 (2+2+2)	12.0	12.0	380-415 V 50 Hz
									14			14.0	14.0	
									16			16.0	16.0	

*1 : tested under EN14511

(water temperature 30 °C → 35 °C at outdoor ambient temperature 7 °C / 6 °C)

*2 : tested under EN14511

(water temperature 23 °C → 18 °C at outdoor ambient temperature 35 °C / 24 °C)

※ All appliances were tested at atmospheric pressure.

How to find additional model information

Energy Labels and Product Fiches for all possible combinations can be found at <https://www.lg.com/global/support/cedoc/cedoc>.

Search for outdoor unit name in cedoc page.

Parts and Dimensions

Indoor unit (For Split IWT) : External

(unit : mm)

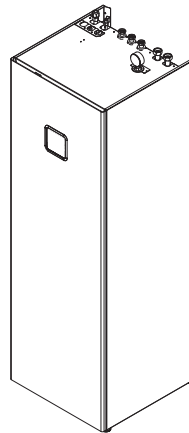
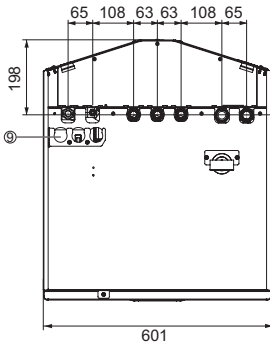
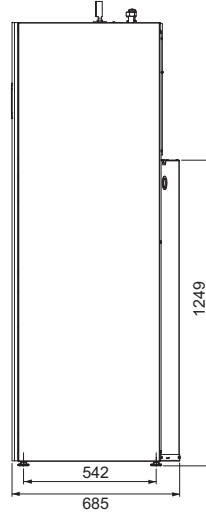
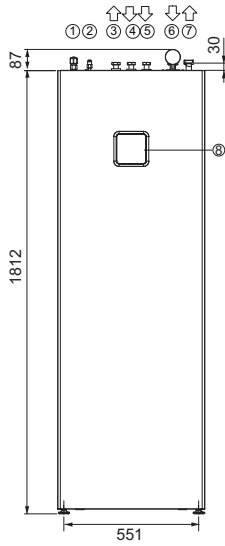

Description

1	SAE 5/8" Refrigerant gas pipe
2	SAE 3/8" Refrigerant liquid pipe
3	G3/4" Domestic hot water outlet
4	G3/4" Domestic cold water Inlet
5	G3/4" DHW Re-circulation
6	G1" Heating circuit inlet
7	G1" Heating circuit outlet
8	Built-in Remote controller
9	Electrical conduits

Indoor unit (For Split IWT) : Internal

(unit : mm)

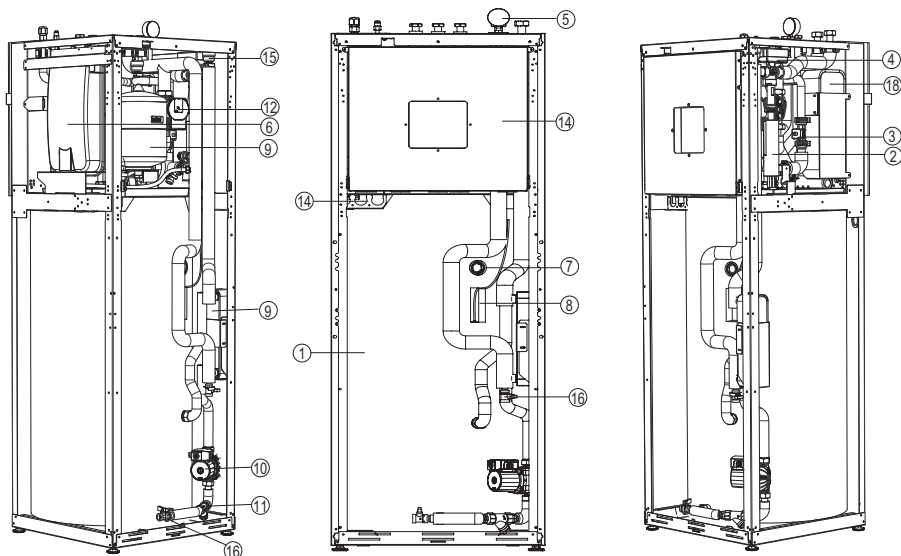

Description

No	Item	No	Item
1	Domestic hot water tank	10	DHW water pump
2	Electric heater	11	DHW strainer
3	Flow sensor	12	Main water pump
4	3-way-valve DHW / Heating	13	DHW Expansion vessel (Accessory)
5	Pressure gauge	14	Control box
6	Expansion vessel for Heating	15	Air vent
7	Magnesium anode	16	Drain cock
8	DHW tank sensor	17	Conduits for electrical wiring
9	Plate-heat-exchanger (Water/DHW)	18	Plate-heat-exchanger (Refrigerant/Water)

Outdoor unit (For Split IWT) : External

Product Heating Capacity :
5 kW, 7 kW, 9 kW
U36A Chassis
(unit : mm)

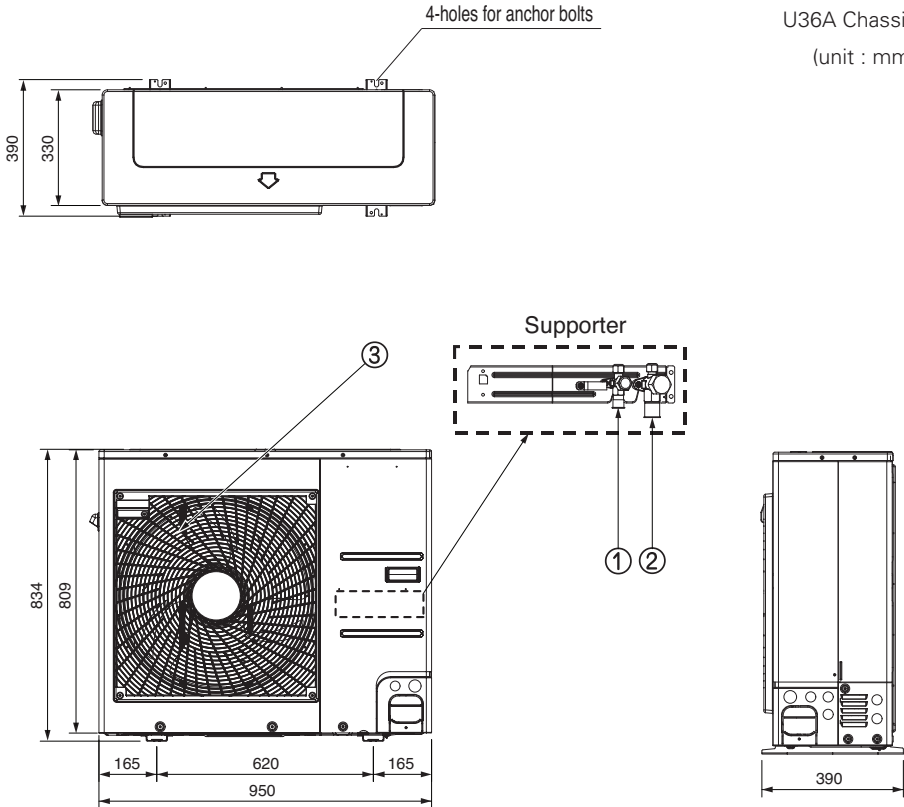

Description

No	Name
1	Liquid-side Service Valve
2	Gas-side Service Valve
3	Air discharge Grille

Indoor unit (For Hydrosplit IWT) : External

(unit : mm)

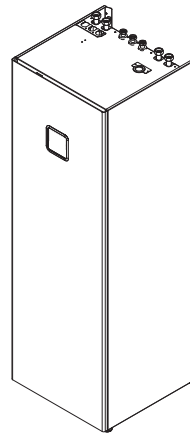
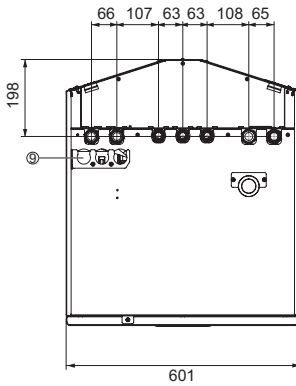
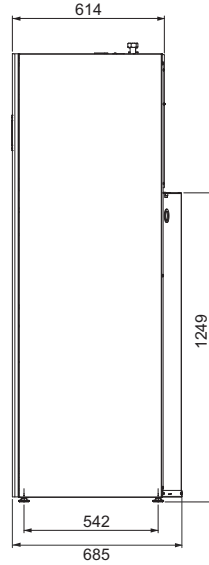
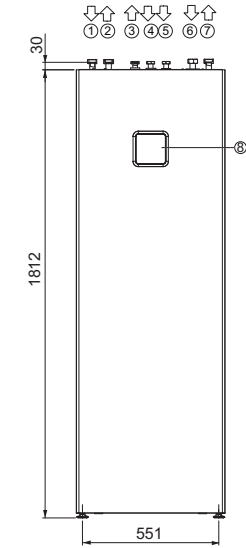

Description

1	G1" Inlet from outdoor unit
2	G1" Outlet to outdoor unit
3	G3/4" Domestic hot water outlet
4	G3/4" Domestic cold water Inlet
5	G3/4" DHW Re-circulation
6	G1" Heating circuit inlet
7	G1" Heating circuit outlet
8	Built-in Remote controller
9	Electrical conduits

Indoor unit (For Hydrosplit IWT) : Internal

(unit : mm)

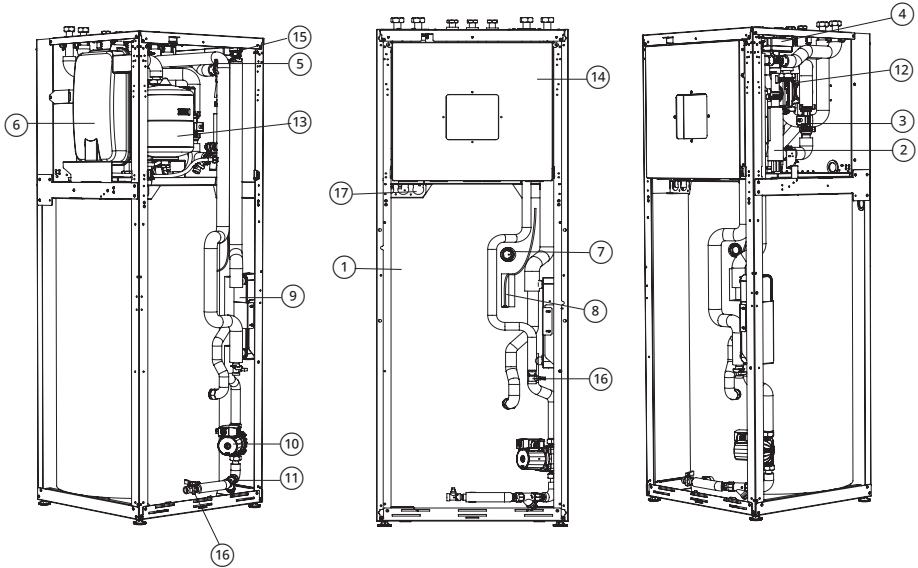

Description

No	Item	No	Item
1	Domestic hot water tank	10	DHW water pump
2	Electric heater	11	DHW strainer
3	Flow sensor	12	Main water pump
4	3-way-valve DHW / Heating	13	DHW Expansion vessel (Accessory)
5	Water pressure sensor	14	Control box
6	Expansion vessel for Heating	15	Air vent
7	Magnesium anode	16	Drain cock
8	DHW tank sensor	17	Conduits for electrical wiring
9	Plate-heat-exchanger (Water/DHW)		

Outdoor unit (For Hydrosplit IWT) : External

Product Heating Capacity : 12 kW, 14 kW, 16 kW
 U60A Chassis
 (unit : mm)

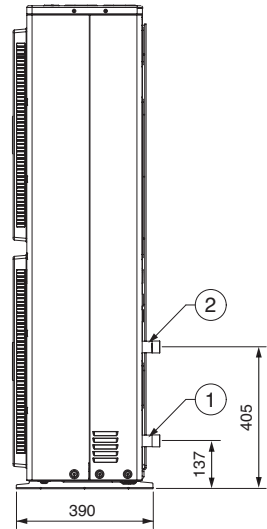
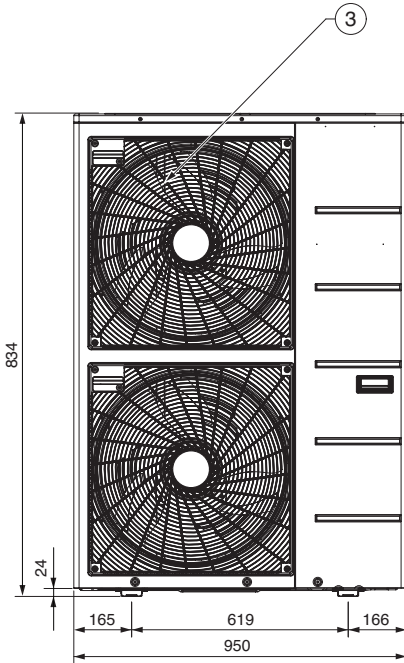
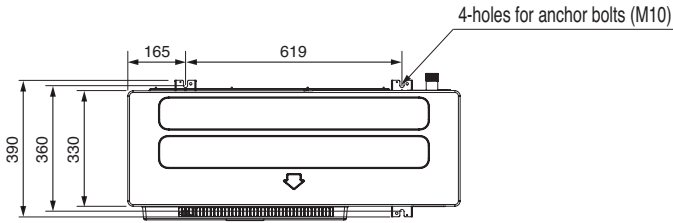

Description

No	Name
1	Entering Water Pipe
2	Leaving Water Pipe
3	Air discharge Grille

Control Parts

Control Box : Indoor Unit (For Split IWT)

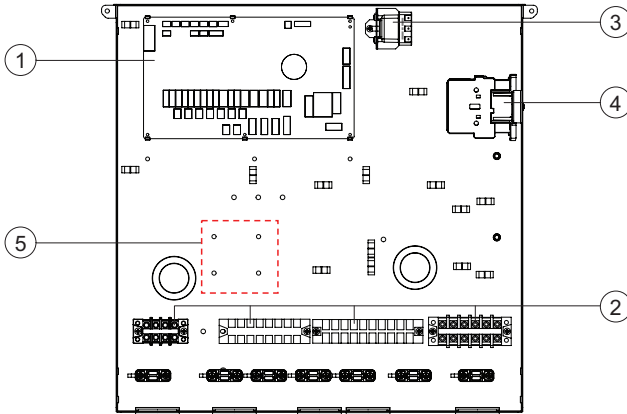

Description

No	Name	Remark
1	Main PCB	The main PCB(Printed Circuit Board) controls the functioning of the unit
2	Terminal blocks	The terminal blocks allow easy connection of field wiring
3	Safety thermostat for Electric heater	The safety thermostat protects the backup heater against overload or short circuit
4	Electric heater Relay	-
5	Holes for dry contact	-

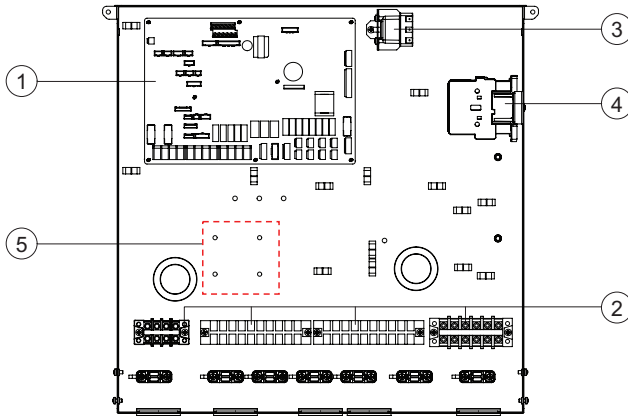
Control Box : Indoor Unit (For Hydrosplit IWT)**Description**

No	Name	Remark
1	Main PCB	The main PCB(Printed Circuit Board) controls the functioning of the unit
2	Terminal blocks	The terminal blocks allow easy connection of field wiring
3	Safety thermostat for Electric heater	The safety thermostat protects the backup heater against overload or short circuit
4	Electric heater Relay	-
5	Holes for dry contact	-

Control Panel

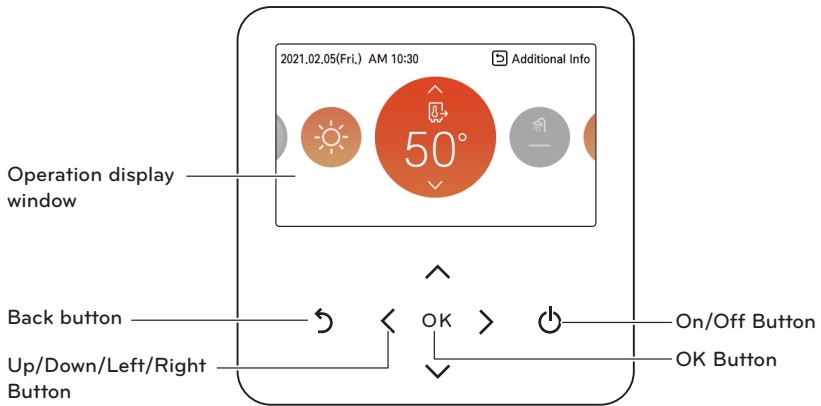

Operation display window	Operation and Settings status display
Back button	When you move to the previous stage from the menu's setting stage
Up/down/left/right button	When you change the menu's setting value
OK button	When you save the menu's setting value
On/Off button	When you turn ON/OFF the AWHP

Typical Installation Example

CAUTION

If **THERMAV** is installed with pre-existing boiler, the boiler and **THERMAV** should not be operated together. If entering water temperature of **THERMAV** is above 55 °C, the system will stop operation to prevent mechanical damage of the product. For detailed electric wiring and water piping, please contact authorized installer. Some installation scenes are presented for example. As these scenes are conceptual figures, installer should optimize the installation scene according to the installation conditions.

CASE 1 : Connecting Heat Emitters for Heating and Cooling & DHW

(Under floor loop, Fan Coil Unit, Radiator, and Domestic hot water)

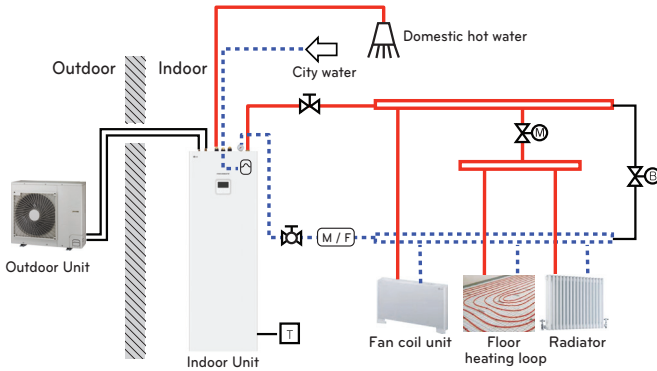

NOTE

- Room thermostat
 - Type of thermostat and specification should be complied with chapter 8 and chapter 9 of **THERMAV** installation manual.
- 2way valve
 - It is important to install 2way valve to prevent dew condensation on the floor and radiator while cooling mode.
 - Type of 2way control valve and specification should be complied with chapter 8 and chapter 9 of **THERMAV** installation manual.
 - 2way valve should be installed at the supply side of the collector.
- By-pass valve
 - To secure enough water flow rate, by-pass valve should be installed at the collector.
 - By-pass valve should guarantee minimum water flow rate in any case. Minimum water flow rate is described in water pump characteristics curve.
- DHW Expansion vessel
 - The cold DHW connection must be fitted with an expansion vessel suitable for drinking water. The selection and installation must be in accordance with the standard DIN 4807 T5.
 - An expansion vessel of 8 l volume that can be integrated into the unit is available as accessory [OSHE-12KT]. the installation method of Expansion vessel can be found in chapter 8 of **THERMAV** installation manual.

High Temperature	2way valve (Field supply)	Room Thermostat (Field supply)
Low Temperature	By-pass valve (Field supply)	DHW Expansion vessel (Accessory)
Magnetic Filter (Mandatory)	Shut-off valve with strainer	Shut-off valve

CASE 2 : Connecting mixed Circuit

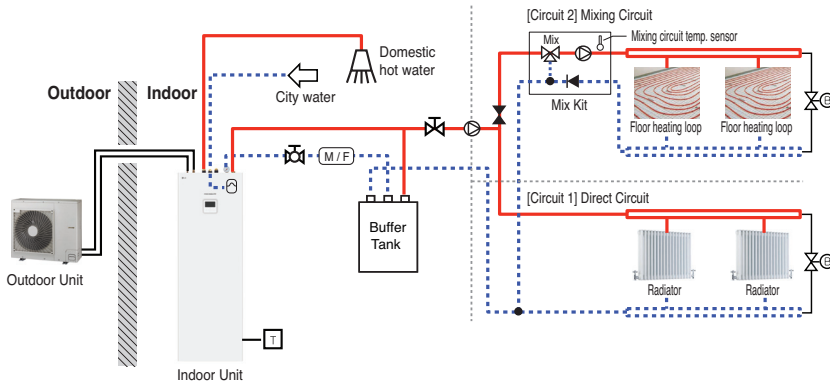

NOTE

- Mix Kit
 - You can install it when you want to set the temperature of two rooms individually
 - When heating, Circuit 2 can not be higher than Circuit 1.
 - When cooling, Circuit 2 can not be lower than Circuit 1.
 - The types and specifications of the Mix Kit are to comply with chapter 8 and chapter 9 of the **THERMAV** Installation Manual.
- Buffer Tank
 - A Buffer tank of 40 l volume that can be integrated into the unit is available as accessory [OSHB-40KT].
 - the installation method of Buffer tank can be found in chapter 8 of **THERMAV** installation manual.
- External pump
 - For Hydrosplit IWT, the location of the external pump may vary depending on the installer settings.

High Temperature	Mix Kit (Field supply)	Room Thermostat (Field supply)
Low Temperature	By-pass valve (Field supply)	DHW Expansion vessel (Accessory)
Magnetic Filter (Mandatory)	Shut-off valve with strainer	Buffer tank (Accessory)
Shut-off valve	Pump (Field supply)	Pressure Regulation valve (Field supply)

CASE 3 : Connecting 3rd Party Boiler

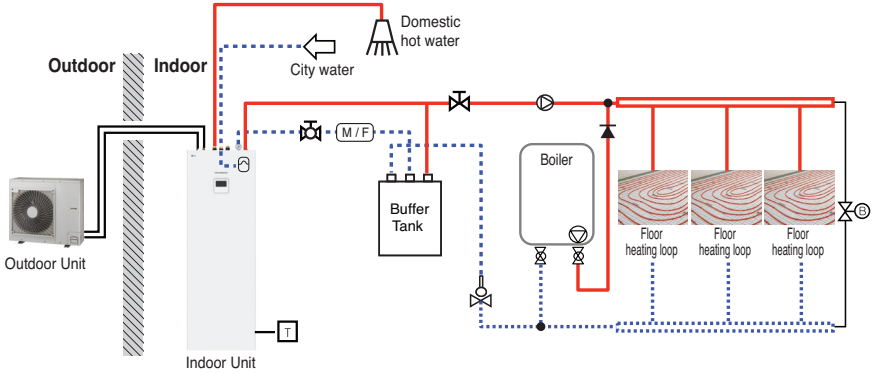

NOTE

- 3rd party Boiler
 - You can control the boiler automatically and manually by comparing the outside temperature and the set temperature.

High Temperature	2way valve (Field supply)	Room Thermostat (Field supply)
Low Temperature	By-pass valve (Field supply)	DHW Expansion vessel (Accessory)
Magnetic Filter (Mandatory)	Shut-off valve with strainer	Buffer tank (Accessory)
Shut-off valve	Pump (Field supply)	Aquistat Valve
Check Valve	Air vent (Field supply)	

For Hydrosplit IWT

Hydrosplit IWT has the same installation scene as Split IWT, Except for connection with outdoor unit.

- The outdoor unit and the indoor unit are connected by water pipes.
- To protect the product, be sure to install a strainer on the outdoor unit water inlet pipe.
- Install an air vent(Field supply) on the highest point of the water connection between outdoor and indoor unit.
- Make sure that the water pipes are protected from freezing in case of heat pump failure or power outage (e.g. Anti-freeze valve, that drains the water if temperature drops too much).

(For Split IWT)

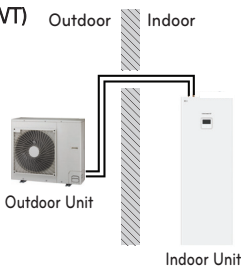

(For Hydrosplit IWT)

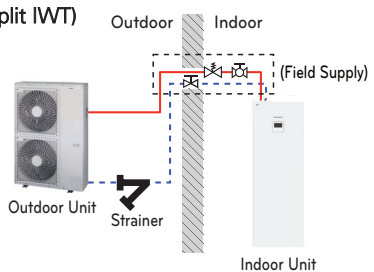

Cycle Diagram (For Split IWT)

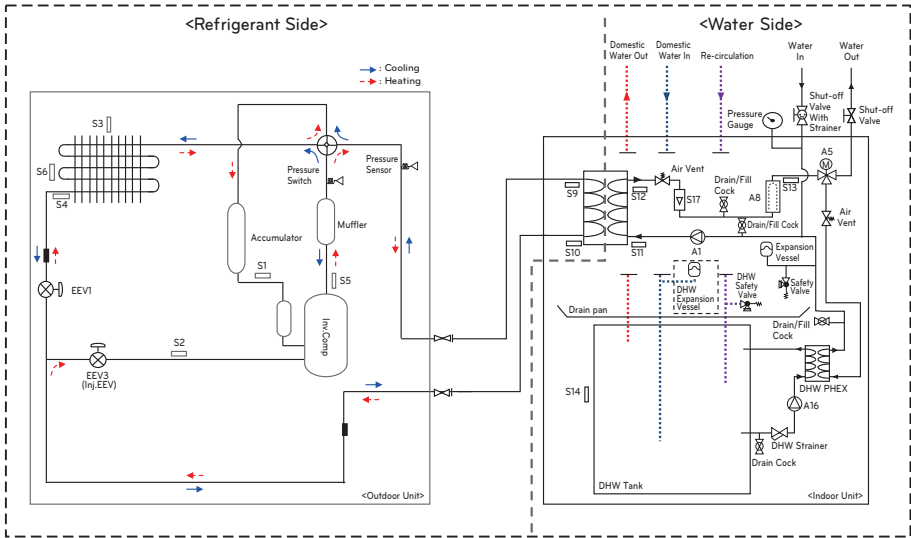

Description

Category	Symbol	Meaning	PCB Connector
Refrigerant side	S1	Compressor-suction pipe temperature sensor	CN_SUCTION
	S2	Inlet IHEX temperature sensor	CN_VI_IN
	S3	Outdoor air temperature sensor	CN_AIR
	S4	Outdoor-HEX temp. sensor	CN_C_PIPE
	S5	Compressor-discharge pipe temperature sensor	CN_DISCHARGE
	S6	Outdoor-HEX middle temp. sensor	CN_MID
	S9	PHEX gas temp. sensor	CN_PIPE/OUT
	S10	PHEX liquid temp. sensor	CN_PIPE/IN
	EEV1	Electronic Expansion Valve (Heating)	CN_EEV1(WH)
	EEV3	Electronic Expansion Valve (Injection)	CN_EEV3(YL)
Water Side	S11	Inlet water temperature sensor	CN_TH3
	S12	Outlet water temperature sensor	
	S13	Electric heater outlet sensor	
	S14	DHW tank temperature sensor	CN_TH4
	S17	Flow sensor	CN_F_METER
	A1	Main water pump	CN_MOTOR1 CN_W_PUMP_A
	A16	DHW Water pump	CN_W_PUMP_B
	A5	3Way Valve	CN_3WAY_A
A8	Electric backup heater	CN_E_HEAT_A	

Cycle Diagram (For Hydrosplit IWT)

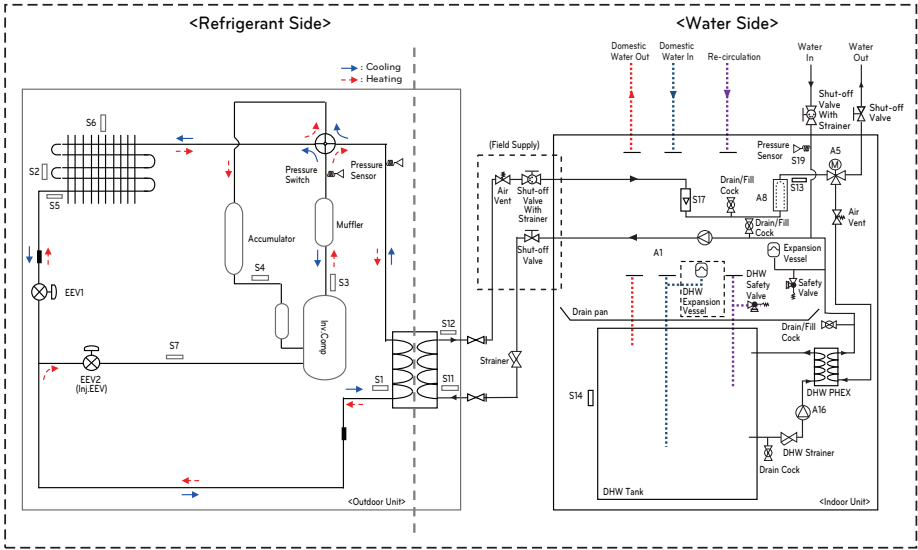

Description

Category	Symbol	Meaning	PCB Connector
Refrigerant side	S1	PHEX liquid temperature sensor	CN_PIPE_IN
	S2	Outdoor-HEX middle temperature sensor	CN_MID
	S3	Compressor-discharge pipe temperature sensor	CN_DISCHARGE
	S4	Compressor-suction pipe temperature sensor	CN_SUCTION
	S5	Outdoor-HEX temperature sensor	CN_C_PIPE
	S6	Outdoor air temperature sensor	CN_AIR
	S7	Compressor-injection pipe temperature sensor	CN_VI_IN
	EEV1	Electronic Expansion Valve (Heating/Cooling)	CN_EEV1
EEV2	Electronic Expansion Valve (Injection)	CN_EEV_MAIN	
Water Side	S11	Inlet water temperature sensor	CN_WATER_IN_BL
	S12	Outlet water temperature sensor	CN_WATER_OUT_BL
	S13	Electric heater outlet sensor	CN_TH3
	S14	DHW tank temperature sensor	CN_TH4
	S17	Flow sensor	CN_F_SENSOR
	S19	Water pressure sensor	CN_H2O_PRESS
	A1	Main water pump	CN_MOTOR1 CN_PUMP_A1
	A16	DHW Water pump	CN_PUMP_A4
A5	3Way Valve	CN_3WAY_A	
A8	Electric backup heater	CN_TANK_HEATER	

Piping Diagram (For Split IWT)

The following diagram shows an exemplary installation scene. For other examples, please ask your local LG Partner for support.

CAUTION

The diagram represents a schematic overview of the required system components and their location. It does not include all necessary components and safety devices according to DIN EN 12828, and eventually required equipment for maintenance and service. Local/national regulation needs to be followed! Subject to technical changes.

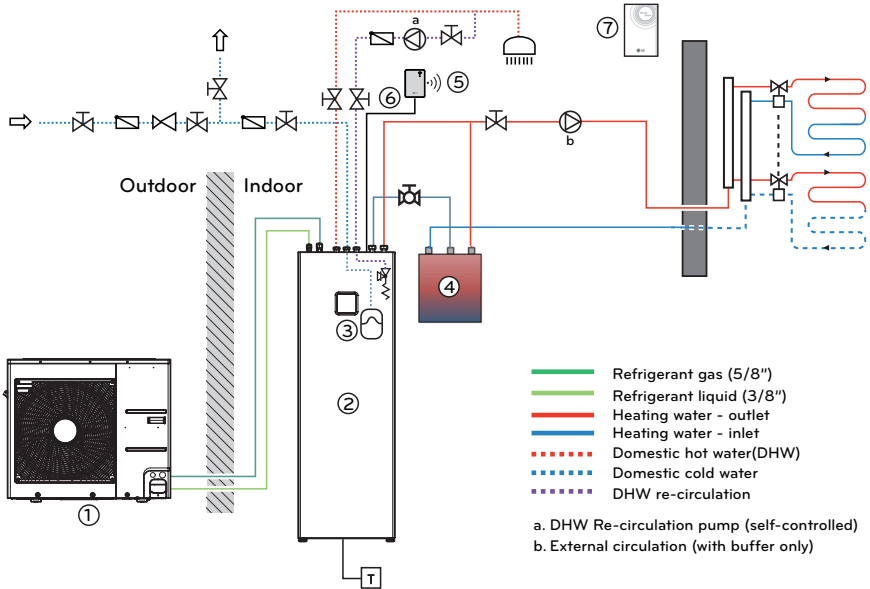

LG supply

- | | |
|---|------------------------------------|
| ① Outdoor unit [HU0X1MR.U44] | ⑤ WiFi modem [PWFMD200] |
| ② Indoor unit [HN0916T.NB1] | ⑥ Extension cable(10m) [PWYREW000] |
| ③ DHW expansion vessel (8l) [OSHE-12KT] | ⑦ Room air sensor [PQRSTA0] |
| ④ Buffer tank (40l) [OSHB-40KT] | |

Piping Diagram (For Hydrosplit IWT)

The following diagram shows an exemplary installation scene. For other examples, please ask your local LG Partner for support.

CAUTION

The diagram represents a schematic overview of the required system components and their location. It does not include all necessary components and safety devices according to DIN EN 12828, and eventually required equipment for maintenance and service. Local/national regulation needs to be followed! Subject to technical changes.

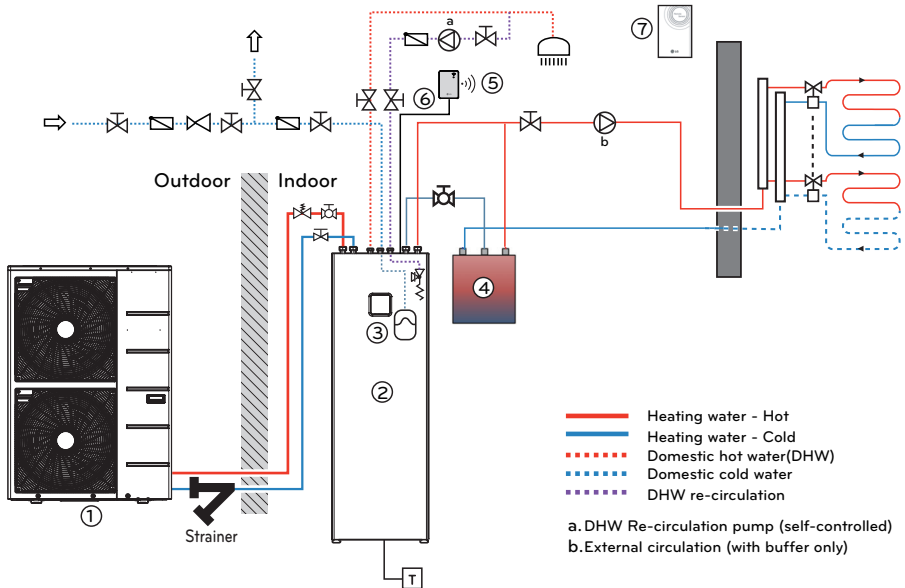

LG supply

- | | |
|---|------------------------------------|
| ① Outdoor unit [HU1XXMRB.U30] | ⑤ WIFI modem [PWFMD200] |
| ② Indoor unit [HN1616Y.NB1] | ⑥ Extension cable(10m) [PWYREW000] |
| ③ DHW expansion vessel (8l) [OSHE-12KT] | ⑦ Room air sensor [PQRSTA0] |
| ④ Buffer tank (40l) [OSHB-40KT] | |

System planning and preparation

The design of the system must be planned and executed by a professional HVAC installer according to European and National regulations and Standards. The following points should be explicitly taken into account.

CAUTION

- Make sure that the minimum water flow rate as given in the Specification is never undercut. Install a Hydraulic separator, buffer tank connected in parallel to the heating system or a bypass valve with sufficient dimension!
- If the heat pump is installed together with an external boiler, the devices should not be operated at the same time. If operated in parallel, take appropriate measures to prevent hot water from entering the heat pump. If the temperature is higher than the operating range of the heat pump it can lead to malfunctions or damage the product.
- When using an Underfloor heating system:
 - Respect the maximum temperature as given by the manufacturer. An independent overheat cut-off device is recommended.
 - When using underfloor cooling, the adequacy of the underfloor system must be approved by the manufacturer.
- General recommendations for Cooling operation:
 - Use diffusion resistant insulation.
 - Carefully agglutinate the joints of the insulation. If air can enter between pipe and insulation, it will get wet and useless.
 - Install a 2-way-valve to block parts of the distribution system that are not designed for cooling. Refer to chapter 3.4.13 for information how to connect the valve.
 - Install external dew point monitor (relay) in combination with dry contact. The relative humidity shall not exceed 65%.
 - Use reversible control valves (heating/cooling) for individual room control (e.g. underfloor thermostats).
- If the unit is connected to an old piping system:
 - A magnetic filter should be installed in the return pipe to protect the unit from particles that can block the heat-exchanger and damage the unit.
 - If pipe diameter is too small (<1 inch) or the pipe diameter is narrowed by scaling, it can lead to flow noise and cause problems due to limitation of water flow rate. Install a parallel buffer tank / hydronic separator.
- Prevention of noise must be taken into account when designing the installation.
 - Calculate the sound emission and respect local laws and regulations, before installing the unit.
 - Do not install the outdoor unit at an exposed position (on top of garage, high at the wall)
 - If possible, prevent installation in a corner of the house or close to other surfaces that concentrates the sound.
 - Prevent structure-borne noise. De-couple the pipes. Install the units on foundations de-coupled from the building. Use dampers.
- Make sure that enough heat is available for Defrosting. If that cannot be ensured by the heating system, install a buffer tank.
- Carefully follow the instructions regarding Condensate drainage and frost-free installation of pipes.

INSTALLATION OF OUTDOOR UNIT

The outdoor unit of **THERMAV™** is installed outside to exchange heat with ambient air. Therefore, it is important to secure proper space around the outdoor unit and care for specific external conditions.

This chapter presents a guide to install the outdoor unit, make a route to connect with the indoor, and what to do when installed around seaside.

Conditions where Outdoor Unit is Installed

- If a sunroof is built over the unit to prevent direct sunlight or rain exposure, make sure that heat radiation from the heat exchanger is not restricted.
- Ensure that the spaces indicated by arrows around front, back and side of the unit.
- Do not place animals and plants in the path of the warm air.
- Take the weight of the outdoor unit into account and select a place where noise and vibration are minimum.
- Select a place so that the warm air and noise from the outdoor unit do not disturb neighbors.

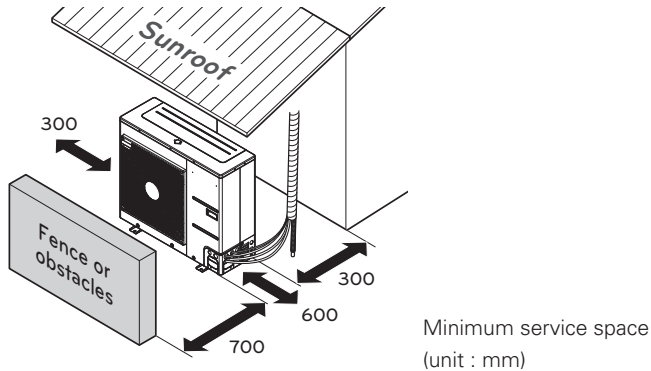

Drill a Hole in the Wall (For Split)

- If making a hole to the wall is required to connect pipe between the indoor unit and the outdoor unit, please follow below descriptions.

Drill the piping hole with a $\varnothing 70$ mm hole core drill.

Piping hole should be slightly slant to the outdoor side to prevent raindrop into indoor side.

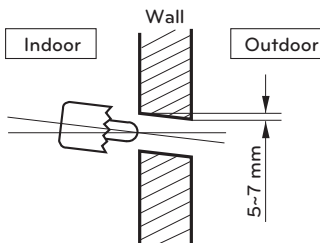

Transporting the Unit

- When carrying the suspended unit, pass the ropes between legs of base panel under the unit.
- Always lift the unit with ropes attached at four points so that impact is not applied to the unit.
- Attach the ropes to the unit at an angle $\text{\textcircled{A}}$ of 40° or less.
- Use only accessories and parts which are of the designated specification when installing.

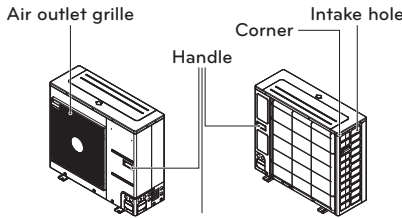
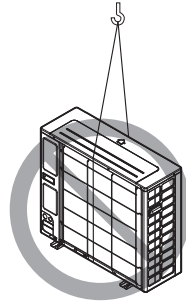
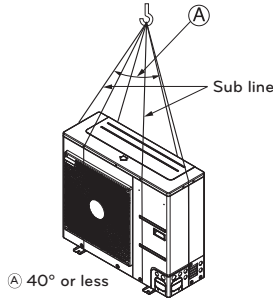

Always hold the unit by the corners, as holding it by the side intake holes on the casing may cause them to deform.

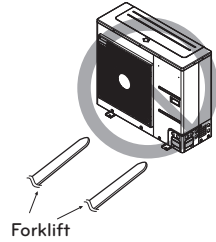

CAUTION

Be very careful while carrying the product.

- Do not have only one person carry product if it is more than 20 kg.
- PP bands are used to pack some products. Do not use them as a mean for transportation because they are dangerous.
- Do not touch heat exchanger fins with your bare hands. Otherwise you may get a cut in your hands.
- Tear plastic packaging bag and scrap it so that children cannot play with it. Otherwise plastic packaging bag may suffocate children to death.
- When carrying in Unit, be sure to support it at four points. Carrying in and lifting with 3-point support may make Outdoor Unit unstable, resulting in a fall.
- Use 2 belts of at least 8 m long.
- Place extra cloth or boards in the locations where the casing comes in contact with the sling to prevent damage.
- Hoist the unit making sure it is being lifted at its center of gravity.

Installation at Seaside

! CAUTION

- AWHP should not be installed in areas where corrosive gases, such as acid or alkaline gas, are produced.
- Do not install the product where it could be exposed to sea wind (salty wind) directly. It can result corrosion on the product. Corrosion, particularly on the condenser and evaporator fins, could cause product malfunction or inefficient performance.
- If outdoor unit is installed close to the seaside, it should avoid direct exposure to the sea wind. Otherwise it needs additional anti-corrosion treatment on the heat exchanger.

Selecting the location(Outdoor Unit)

- If the outdoor unit is to be installed close to the seaside, direct exposure to the sea wind should be avoided. Install the outdoor unit on the opposite side of the sea wind direction.

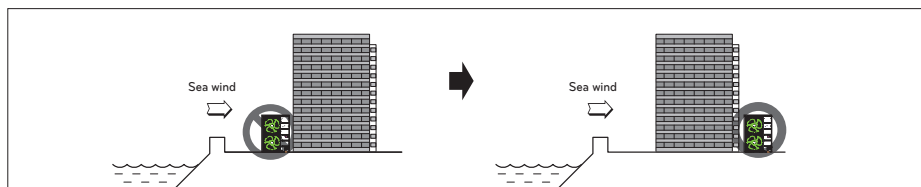

- In case, to install the outdoor unit on the seaside, set up a windbreak not to be exposed to the sea wind.

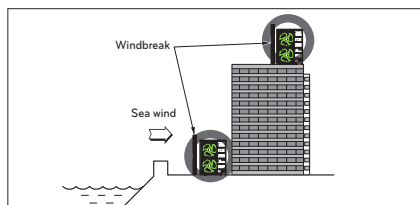

- It should be strong enough like concrete to prevent the sea wind from the sea.
- The height and width should be more than 150% of the outdoor unit.
- It should be keep more than 700 mm of space between outdoor unit and the windbreak for easy air flow.
- Select a well-drained place.
Periodic (more than once/year) cleaning of the dust or salt particles stuck on the heat exchanger by using water.
- If you can't meet above guide line in the seaside installation, please contact your supplier for the additional anti-corrosion treatment.

Seasonal Wind and Cautions in Winter

In areas with low ambient temperature, high humidity, or heavy snowfall, particular measures are required to ensure that the unit operates properly.

- Install the unit so that it does not come into direct contact with snow. If snow accumulates and freezes in the air inlet, the system may malfunction. When installing in an area with heavy snowfall, attach the hood to the system.
- Install the suction and discharge ducts to prevent the entry of snowfall or rainfall.
- When installing in an area with heavy snowfall, install it on an installation console which is 500mm higher than the average snowfall (annual average snowfall).
- The height of the H frame must be at least twice the amount of snowfall and its width must not exceed the width of the unit. (Snow may accumulate if the width of the frame is wider than the width of the unit.)
- If condensed water from the outdoor unit freezes around the product, the floor/ground may become slippery and cause an accident, so do not install the outdoor unit near a sidewalk. If it is unavoidable, install a water channel or drainage pipe to prevent condensed water from flowing onto the sidewalk.
- Use "Rapid Defrost Mode" in sites with snowfall or low temperatures and high humidity.
 - * The Rapid Defrost Mode is a rapid defrost mode designed to prevent accumulated icing in sites with snowfall or low temperatures and high humidity. Refer to "Dip Switch Setting".
- If more than 100mm of snow has accumulated on the top of the product, be sure to remove the snow before carrying out any work on the unit.
- Do not install the inlet or outlet of the unit so that they face seasonal winds.
- Make preparations for snow and/or seasonal winter winds in all areas in which the unit is installed.

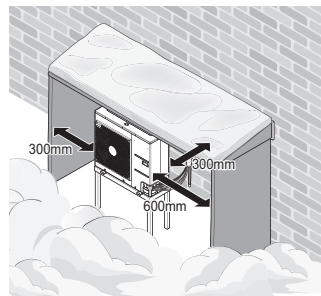
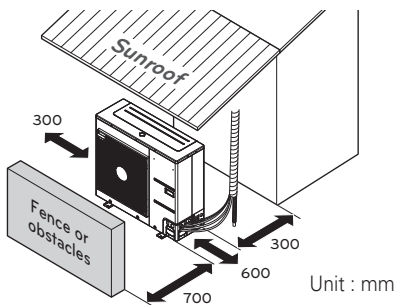

INSTALLATION OF INDOOR UNIT

The indoor unit of **THERMAV** is installed inside where terminal of under floor water pipe cycle and refrigerant pipe from the outdoor unit are accessible at the same time.

In this chapter conditions for installation place is described. In addition, considerations when installing accessories or 3rd party accessories are described, too.

Conditions where Indoor Unit is Installed

Specific conditions are required for installation place such as service space, condensate drainage, water pipe length and height, total volume of water, adjusting expansion vessel, and water quality.

General Considerations

Followings are should be considered before the installation of the indoor unit.

- The installation place should be free from outdoor weather conditions such as rain, snow, wind, frost, etc.
- Choose the place where is water-resistant or good drainage.
- Service space should be secured.
- No flammable materials around the indoor unit.
- Mice can not be appeared to prevent entering the indoor unit or attacking wires.
- Do not place anything in front of the indoor unit to ensure air circulation around the indoor unit.
- Do not locate anything under the indoor unit to be free from unexpected water out.
- In case of water pressure increasing to 3 bar or tank pressure increasing to 10 bar, water drainage should be treated when water is drained by safety valve.

WARNING

Do not block the venting openings on the backside of the unit! (For Split IWT)

CAUTION

The device must not be installed under pipelines because there is a possibility of condensate forming. Ingress of water condensate can cause disturbances in the operation.

NOTICE

The installation location of the indoor unit must be dry and in the temperature range between +10 °C and 40 °C, for a short period (up to 24h) also up to 55 °C.

Service Space

- Ensure that the spaces indicated by arrows around front, right, and top side.
- Wider spaces are preferred for easy maintenance and piping.
- If minimum service space is not secured, air circulation can be troubled and internal parts of the indoor unit can be damaged by overheating.

NOTE

- Provide enough space for servicing and air circulation. The unit is designed to allow servicing from front side. However, if it becomes necessary to replace components, a service area of approximately 500 mm on the right side, makes the task much easier.

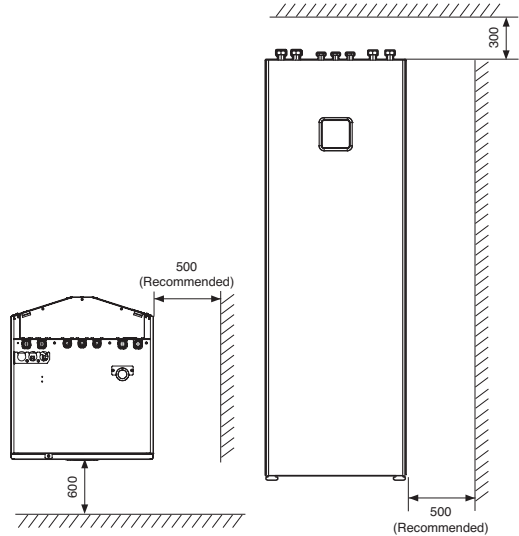

Minimum service space
(unit : mm)

Transporting the Unit

CAUTION

- The device must be transported with transport devices.
- Secure the device during transport to prevent damage.
- The device must not be stacked and other objects must not be placed on it.
- Appropriate transport equipment must be used for installing the device. Safety regulations and good practice have to be applied.
- When lifting the unit, use the dedicated carrying handles at bottom and backside of the product
- Tilt over the unit carefully with at least two persons

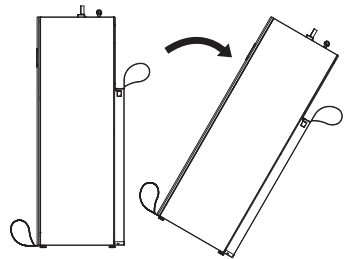

Connecting Condensate drainage

Step 1. Before the indoor unit's final positioning, attach the flexible $\varnothing 16$ hose to the drainpipe, which has been prepared in advance. Insert the drainage hose into the drain ①, which leads to the sinkhole or storm drain. Seal the gap with a suitable gasket.

Step 2. Then push the appliance to the wall ②.

CAUTION

- Attaching the hose for the condensate drain to the sewer hose can cause corrosion of the appliance's internal components.
- The drain pipe must have an odor trap!

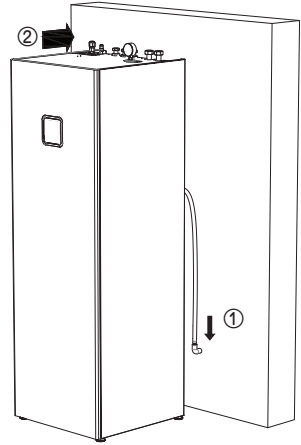

Step 3. Before connecting any pipes, level the indoor unit with supplied adjustable levelling feet.

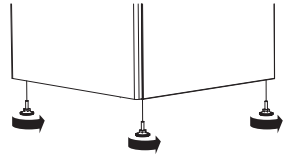

Front Panel Removal

Step 1. After releasing a screw from the top the Indoor unit, detach front panel ①.

Step 2. Tilt the front panel towards you ② and lift it ③ for opening

Step 3. Before taking front panel off completely, disconnect the cable of the remote controller ④.

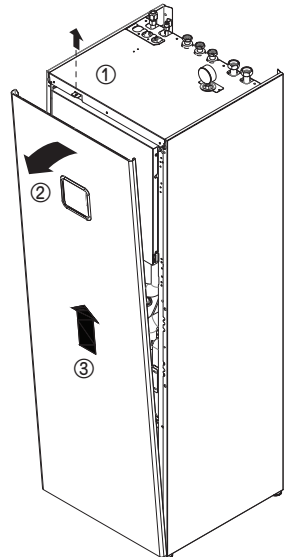
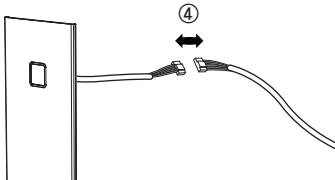

CAUTION

After installation is completed, reconnect the cable of remote controller.

Floor area requirement : Indoor unit (For Split IWT)

- If the total refrigerant charge (m_c) is in system ≥ 1.842 kg, additional minimum floor area requirements is complied in the following flow chart.

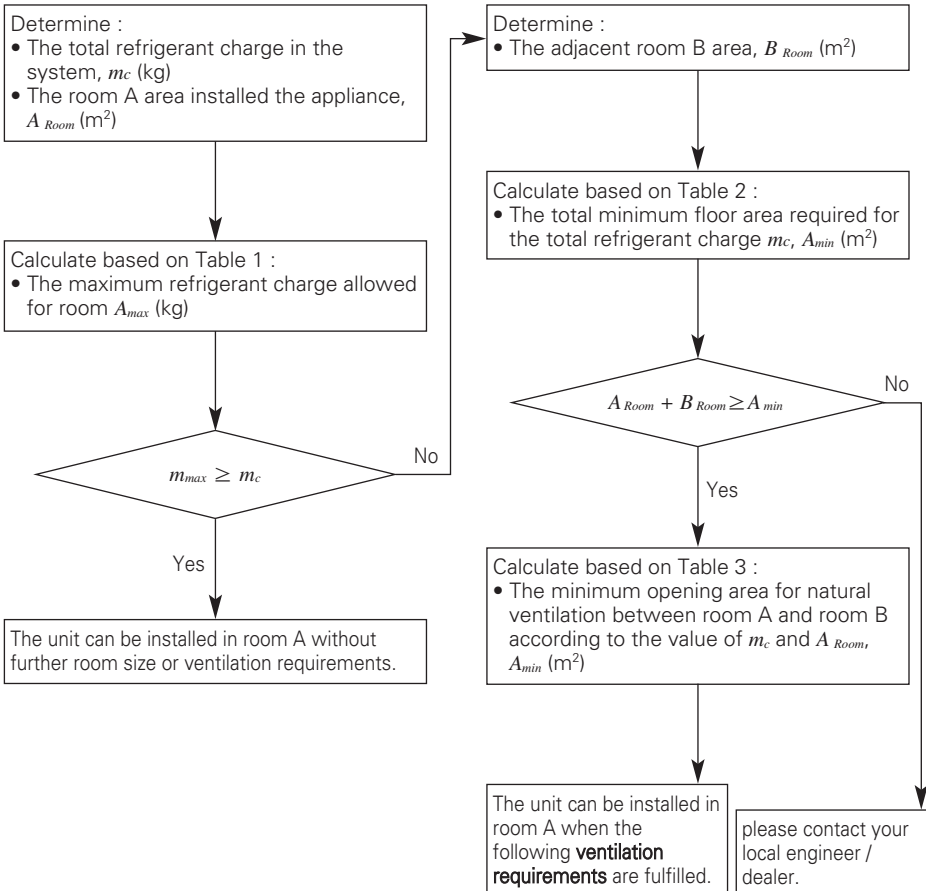
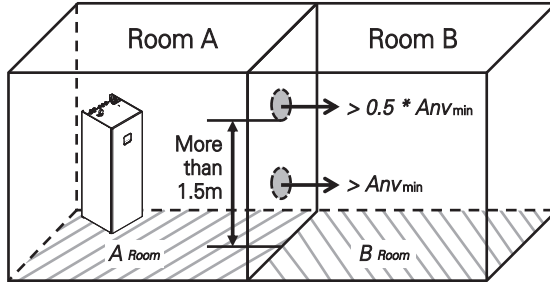

Ventilation requirements

- Two ventilation openings, one at bottom, another at top, for ventilation purposes are made between room A and room B.
- Bottom opening :
 - Must comply to the minimum area requirement of Anv_{min} .
 - Opening must be located 300mm from the floor.
 - At least 50% of required opening area must be 200mm from the floor.
 - The bottom of the opening shall not be higher than the point of release when the unit is installed and must be situated 100mm above the floor.
 - Must be as close as possible to the floor and lower than h_0 .
(h_0 =Installation height, The value of h_0 in this unit is considered as 1.2m)
- Top opening :
 - The total size of the Top opening must be more than 50% of Anv_{min}
 - Opening must be located 1500mm above the floor.
- The height of the openings between the wall and floor which connect the rooms are not less than 20 mm.
- Ventilation openings to the outside are NOT considered suitable ventilation openings (the user can block them when it is cold).

Table 1 - Maximum refrigerant charge allowed in a room

A_{room} (m ²)	Maximum refrigerant charge in a room m_{max} (kg)	
	Based on h_0 1.2 m	
1		0.28
2		0.55
3		0.83
4		1.11
5		1.38
6		1.66
7		1.81
8		1.94
9		2.06
10		2.17
11		2.27
12		2.37
13		2.47
14		2.57
15		2.66
16		2.74
17		2.83
18		2.91
19		2.99
20		3.07
21		3.14

NOTE

- The value of "Release height (h_0)" in this unit is considered 1200 mm to comply to IEC 60335-2-40:2013 A1 2016 Clause GG2.
- For intermediate A_{room} values, the value that corresponds to the lower A_{room} value from the table is considered. (If $A_{room}=10.5$ m², consider the value that corresponds to $A_{room}=10$ m².)

Table 2 - Minimum floor area

Total Ref. Amount m_c (kg)	Minimum Floor Area A_{min} (m ²)
	Based on h_0 1.2 m
1.84	7.20
1.86	7.36
1.88	7.52
1.90	7.68
1.92	7.84
1.94	8.01
1.96	8.17
1.98	8.34
2.00	8.51
2.02	8.68
2.04	8.85
2.06	9.03
2.08	9.21
2.10	9.38
2.12	9.56
2.14	9.74
2.16	9.93
2.18	10.11
2.20	10.30
2.22	10.49
2.24	10.68
2.26	10.87
2.28	11.06
2.30	11.26
2.32	11.45
2.34	11.65
2.36	11.85
2.38	12.05
2.40	12.26
2.42	12.46
2.44	12.67
2.46	12.88
2.48	13.09
2.50	13.30
2.52	13.51
2.54	13.73
2.56	13.94
2.58	14.16
2.60	14.38
2.62	14.61
2.64	14.83
2.66	15.05
2.68	15.28
2.70	15.51
2.72	15.74
2.74	15.97
2.76	16.21

Total Ref. Amount m_c (kg)	Minimum Floor Area A_{min} (m ²)
	Based on h_0 1.2 m
2.78	16.44
2.80	16.68
2.82	16.92
2.84	17.16
2.86	17.40
2.88	17.65
2.90	17.89
2.92	18.14
2.94	18.39
2.96	18.64
2.98	18.89
3.00	19.15
3.02	19.41
3.04	19.66
3.06	19.92
3.08	20.18
3.10	20.45

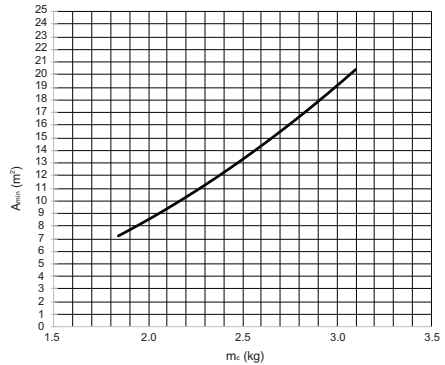

NOTE

- The value of "Release height (h_0)" in this unit is considered 1200 mm to comply to IEC 60335-2-40:2013 A1 2016 Clause GG2.
- For intermediate m_c values, the value that corresponds to the higher m_c value from the table is considered.
(If $m_c = 1.85$ kg, the value that corresponds to $m_c = 1.86$ kg is considered.)
- Systems with total refrigerant charge lower than 1.84 kg are not subjected to any room area requirements.
- Charges above 3.10 kg are not allowed in the unit.

Table 3 - Minimum venting opening area for natural ventilation

A_{room} (m^2)	Minimum opening area $A_{\text{nv_min}}$ (cm^2) (Based on h_0 1.2 m)													
	Total Ref. Amount m_c (kg)													
	3.1	3.0	2.9	2.8	2.7	2.6	2.5	2.4	2.3	2.2	2.1	2.0	1.9	
1	808	779	751	722	693	665	636	607	579	550	522	493	464	
2	729	700	671	643	614	586	557	528	500	471	443	414	385	
3	650	621	592	564	535	507	478	449	421	392	364	335	306	
4	571	542	513	485	456	428	399	370	342	313	285	256	227	
5	492	463	434	406	377	349	320	291	263	234	206	177	148	
6	413	384	355	327	298	270	241	212	184	155	126	98	69	
7	380	350	321	291	262	232	203	173	144	114	85	55	25	
8	355	324	293	263	232	202	171	141	110	80	49	19		
9	328	297	265	234	202	171	139	108	77	45	14			
10	301	269	236	204	172	140	107	75	43	10				
11	273	240	207	174	141	108	75	42	9					
12	245	211	177	144	110	76	42	9						
13	217	182	148	113	79	44	10							
14	188	153	118	83	47	12								
15	159	123	88	52	16									
16	130	94	57	21										
17	101	64	27											
18	72	34												
19	42	4												
20	13													

NOTE

- The value of "Release height (h_0)" in this unit is considered 1200 mm to comply to IEC 60335-2-40:2013 A1 2016 Clause GG2.
- For intermediate A_{room} values, the value that corresponds to the lower A_{room} value from the table is considered. (If $A_{\text{room}}=10.5 \text{ m}^2$, consider the value that corresponds to $A_{\text{room}}=10 \text{ m}^2$.)
- For intermediate m_c values, the value that corresponds to the higher m_c value from the table is considered. (If $m_c = 2.15 \text{ kg}$, the value that corresponds to $m_c = 2.2 \text{ kg}$ is considered.)

Electrical Wiring

Two kind of cables should be connected to the outdoor unit : One is 'Power cable', the other one is 'Connecting cable'. Power cable is a cable which is used to supply external electricity to the outdoor unit. This cable is generally connected between external power source (such as main electric power distribution panel of user's house) and the outdoor unit. Connecting cable is, on the other hand, used to connect between the outdoor unit and the indoor unit to supply electric power to the indoor unit and to establish the communication between the outdoor unit and the indoor unit.

Procedure for wiring to the outdoor unit is four steps. Before starting wiring, check if wire specification is suitable and read following directions and cautions VERY carefully.

CAUTION

The power cord connected to the outdoor unit should be complied with IEC 60245 or HD 22.4 S4 (This equipment shall be provided with a cord set complying with the national regulation.)

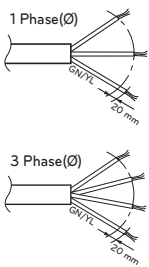

NORMAL CROSS-SECTIONAL AREA

Model Name		Area (mm ²)	Cable Type	
Phase (Ø)	Capacity (kW)			
1	5	4	H07RN-F	
	7			
	9			
	12			
3	14	6		
	16			
	12			2.5
	14			
16				

The connecting cable connected to the outdoor unit should be complied with IEC 60245 or HD 22.4 S4 (This equipment shall be provided with a cord set complying with the national regulation.)

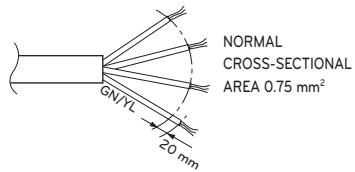

When the connection line between the indoor unit and outdoor unit is over 40 m, connect the telecommunication line and power line separately.

In order to avoid a hazard due to inadvertent resetting of the thermal cut-out, this appliance must not be supplied through an external switching device, such as a timer, or connected to a circuit that is regularly switched on and off by the utility.

If the supply cord is damaged, it must be replaced by the manufacturer, its service agent or similarly qualified persons in order to avoid a hazard.

Precautions when laying power wiring

Use round pressure terminals for connections to the power terminal block.

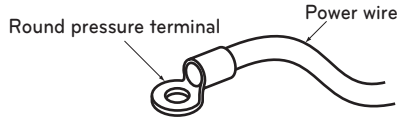

When none are available, follow the instructions below.

- Do not connect wiring of different thicknesses to the power terminal block. (Slack in the power wiring may cause abnormal heat.)
- When connecting wiring which is the same thickness, do as shown in the figure below.

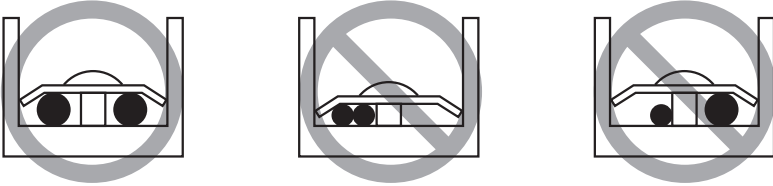

- For wiring, use the designated power wire and connect firmly, then secure to prevent outside pressure being exerted on the terminal block.
- Use an appropriate screwdriver for tightening the terminal screws. A screwdriver with a small head will strip the head and make proper tightening impossible.
- Over-tightening the terminal screws may break them.

WARNING

Make sure that the screws of the terminal are free from looseness.

Point for attention regarding quality of the public electric power supply

- European/International Technical Standard setting the limits for voltage changes, voltage fluctuations and flicker in public low-voltage supply systems for equipment with rated current ≤ 75 A.
- European/International Technical Standard setting the limits for harmonic currents produced by equipment connected to public low-voltage systems with input current ≤ 16 A or > 75 A per phase.

For Split IWT

- This equipment complies with IEC (EN) 61000-3-12 in harmonic currents emission limits corresponding $R_{sce} = 33$.
- This equipment complies with IEC (EN) 61000-3-3.

For Hydrosplit IWT/ 1 Phase

- This equipment complies with IEC (EN) 61000-3-12 in harmonic currents emission limits corresponding $R_{sce} = 33$.
- This equipment complies with reference impedance for IEC (EN) 61000-3-11.

For Hydrosplit IWT/ 3 Phase

- This equipment complies with IEC (EN) 61000-3-12 provided that the short-circuit power S_{sc} is greater than or equal to 1959 kVA at the interface point between the user's supply and the public system. It is the responsibility of the installer or user of the equipment to ensure, by consultation with the distribution network operator if necessary, that the equipment is connected only to a supply with a short-circuit power S_{sc} greater than or equal to 1959 kVA.
- This equipment complies with IEC (EN) 61000-3-3.

1Ø Electric Heater

- This equipment complies with IEC (EN) 61000-3-12 in harmonic currents emission limits corresponding $R_{sce} = 33$.
- This device is intended for the connection to a power supply system with a maximum permissible system impedance Z_{MAX} of 0.4516Ω at the interface point (power service box) of the user's supply. The user has to ensure that this device is connected only to a power supply system which fulfills the requirement above. If necessary, the user can ask the public power supply company for the system impedance at the interface point.

3Ø Electric Heater

- This equipment complies with IEC (EN) 61000-3-2.
- This equipment complies with IEC (EN) 61000-3-3.

Circuit Breaker Specification

Perform the electrical wiring work according to the electrical wiring connection.

- All wiring must comply with local requirements.
- Select a power source that is capable of supplying the current required by the air conditioner.
- Use a recognized ELCB (Earth Leakage Circuit Breaker) between the power source and the unit.
- A disconnection device to adequately disconnect all supply lines must be fitted.
- Model of circuit breaker recommended by authorized personnel only.

When the electrical phase of outdoor unit and heater is same

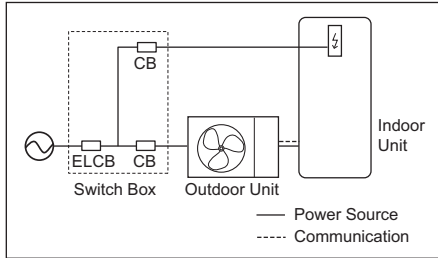

When the electrical phase of outdoor unit and heater is NOT same

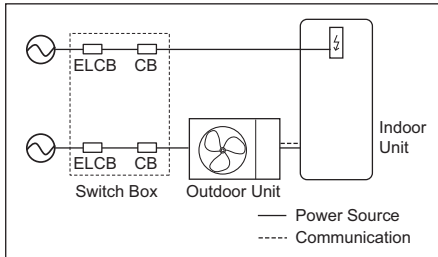

Type	Capacity [kW]	Phase [Ø]	Area [mm ²]	ELCB [A]
Split	5 / 7 / 9	1	4	16 / 20 / 25
Hydrosplit	12 / 14 / 16	1	6	40
	12 / 14 / 16	3	2.5	16

Type	Capacity [kW]	Phase [Ø]	Area [mm ²]	Maximum Current [A]
Electric Heater	2 / 4	1	4	11.1 / 19.9
	6	3	2.5	11.1

PIPING AND WIRING FOR OUTDOOR UNIT

Procedures about refrigerant piping, water piping and electric wiring at the outdoor are described in this chapter. Most of procedures are similar to those of LG Air Conditioner.

*Pipes and wires should be purchased separately for installation of the product.

Refrigerant Piping (For Split IWT)

Before starting refrigerant piping, constraints in pipe length and elevation should be examined. After resolving all constraints, some preparations are required to proceed. Then connecting pipe to the outdoor and the indoor unit is beginning.

Constraints in Pipe Length and Elevation

Refrigerant	Capacity (kW)	Pipe Diameter [mm(inch)]		Length A (m)		Elevation B (m)	Additional Refrigerant (g/m) 40 (longer than 10 m)
		Gas	Liquid	Standard	Max.	Max.	
R32	5/7/9	15.88(5/8")	9.52(3/8")	5	50	30	

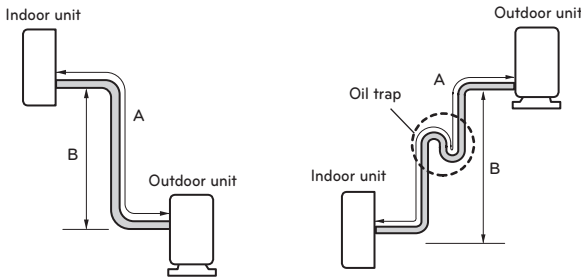

CAUTION

- For R32 products, standard pipe length is 5 m, If the pipe length is longer than 10 m, additional charge of the refrigerant is required according to the table.
 - Example : If R32 9 kW model is installed at a distance of 50 m, 1 600 g of refrigerant should be added according to following formula : $(50-10) \times 40 \text{ g} = 1 600 \text{ g}$
- Rated capacity of the product is based on standard length and maximum allowable length is based on the product reliability in the operation.
- Improper refrigerant charge may result in abnormal operation.
- Oil trap should be installed every 10 meters.
- Installing a refrigerant pipe that is shorter than the standard length may result in noise or abnormal operation of the product.

NOTE

Fill in the f-gas Label attached on outdoor about the quantity of the fluorinated greenhouse gases (This note about f-gas label may not apply depending on your product type or market.)

- Manufacturing site (See Model Name label)
- Installation site (If possible being placed adjacent to the service points for the addition or removal of refrigerant)
- The total Charge (① + ②)

Preparation for Piping

- Main cause of gas leakage is defect in flaring work. Carry out correct flaring work in the following procedure.
- Use the de-oxidised copper as piping materials to install.

Step 1. Cut the pipes and the cable.

- Use the accessory piping kit or the pipes purchased locally.
- Measure the distance between the indoor unit and the outdoor unit.
- Cut the pipes a little longer than measured distance.
- Cut the cable 1.5 m longer than the pipe length.

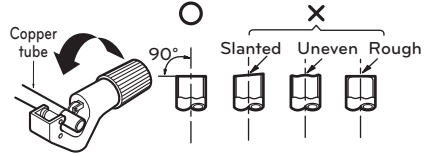

Step 2. Burrs removal

- Completely remove all burrs from the cut cross section of pipe/tube.
- Put the end of the copper tube/pipe to downward direction as you remove burrs in order to avoid to let burrs drop in the tubing.

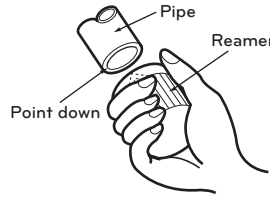

Step 3. Putting nut on

- Remove flare nuts attached to indoor and outdoor units, than put them on pipe/tube having completed burr removal. (Not possible to put them on after flaring work)

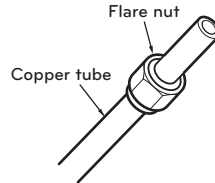

Step 4. Flaring work.

- Carry out flaring work using dedicated flaring tool as shown below.

Pipe diameter [inch(mm)]	A inch (mm)	
	Wing nut type	Clutch type
1/4 (6.35)	0.04~0.05(1.1~1.3)	0~0.02 (0~0.5)
3/8 (9.52)	0.06~0.07(1.5~1.7)	
1/2 (12.7)	0.06~0.07(1.6~1.8)	
5/8 (15.88)	0.06~0.07(1.6~1.8)	
3/4 (19.05)	0.07~0.08(1.9~2.1)	

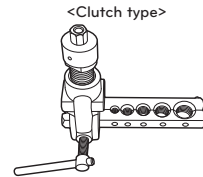
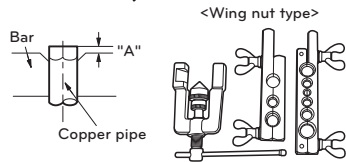

- Firmly hold copper tube in a bar(or die) as indicated dimension in the table above.

Step 5. Check

- Compare the flared work with right figure.
- If flare is seemed to be defective, cut off the flared section and do flaring work again.

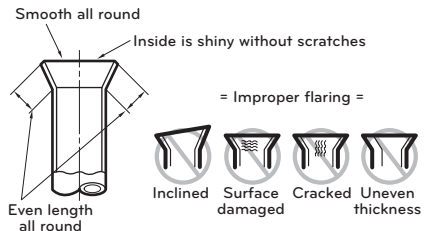

Even length all round

Inclined

Surface damaged

Cracked

Uneven thickness

Connecting Pipe to Indoor Unit

Connecting pipe to the indoor unit is two steps. Read following directions carefully.

Step 1. Pre-tightening.

- Align the center of the pipes and sufficiently tighten the flare nut by hand.

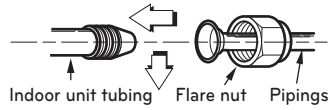

Step 2. Tightening.

- Tighten the flare nut with a wrench.
- Tightening torque is as following.

Outside diameter [mm(inch)]	Torque [kgf-m]
6.35 (1/4)	1.8 ~ 2.5
9.52 (3/8)	3.4 ~ 4.2
12.7 (1/2)	5.5 ~ 6.6
15.88 (5/8)	6.6 ~ 8.2
19.05 (3/4)	9.9 ~ 12.1

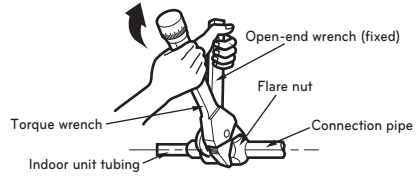

Connecting Pipe to Outdoor Unit

Connecting pipe to the outdoor unit is five steps including PCB setting.

Step 1. Determine direction of pipes.

- The pipes can be connectable in three directions.
- The directions are expressed in below figure.
- When connecting in a downward direction, knock out the knock-out hole of the base pan.
- Detailed geometry may vary by model.

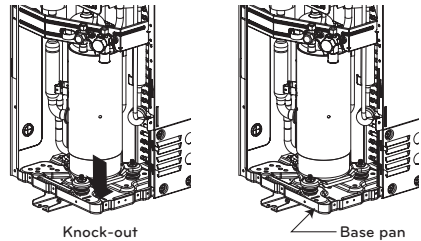
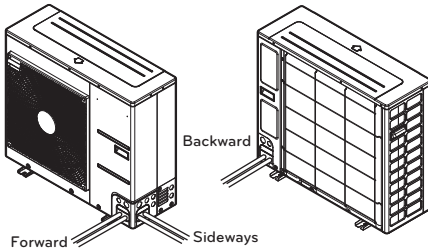

Step 2. Tightening

- Align the center of the pipes and sufficiently tighten the flare nut by hand.
- Tighten the flare nut with a wrench until the wrench clicks.
- Tightening torque is as following.

Outside diameter [mm(inch)]	Torque [kgf·m]
6.35 (1/4)	1.8 ~ 2.5
9.52 (3/8)	3.4 ~ 4.2
12.7 (1/2)	5.5 ~ 6.6
15.88 (5/8)	6.6 ~ 8.2
19.05 (3/4)	9.9 ~ 12.1

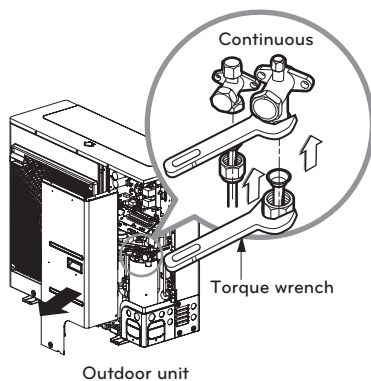
**Step 3. Preventing entering of foreign objects**

- Plug the pipe through-holes with putty or insulation material (procured locally) to fill up all gaps as shown in right figure.
- If insects or small animals enter the outdoor unit, it may cause a short circuit in the electrical box.
- Finally, form the pipes by wrapping the connecting portion of the indoor unit with insulation material and secure it with two kinds of vinyl tape. Ensuring thermal insulation is very important.

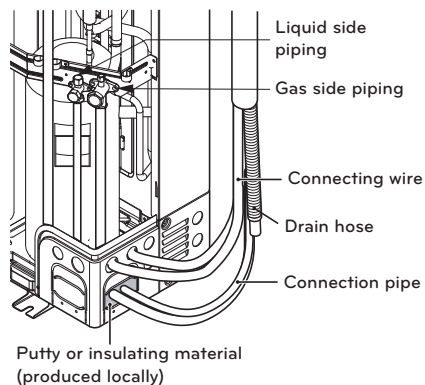

Water Piping (For Hydrosplit IWT)

Before starting water piping between outdoor unit and indoor unit, read chapter 7 described General considerations, water charging, and pipe insulations about water piping.

Step 1. Connect the water pipes at outdoor unit.

- Check the location inlet and outlet.
- When the water pipes are connected. It must be tightened the nut with two wrench.
- Otherwise pipes can be deformed.
- Maximum allowable Torque at the water piping connection is 50 N-m

NOTE

To protect the product, be sure to install a provided strainer on the outdoor unit water inlet pipe.

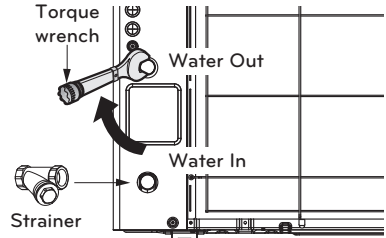

Step 2. Connect the water pipes at indoor unit.

- Before connecting pipes, use the provided gasket (G1") for each pipe at indoor unit.
- Check the location inlet and outlet.

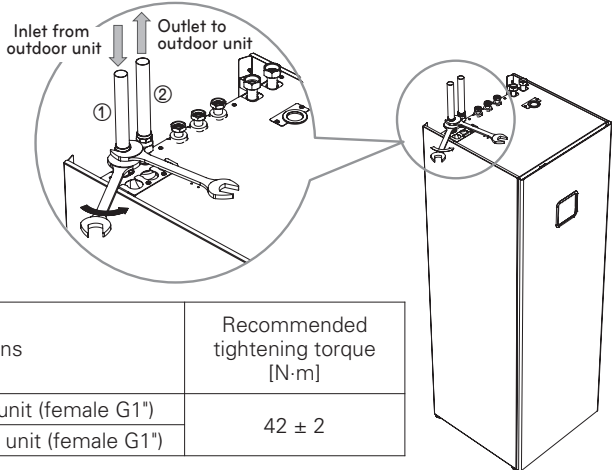

No.	Connections	Recommended tightening torque [N-m]
①	Inlet pipe from outdoor unit (female G1")	42 ± 2
②	Outlet pipe from outdoor unit (female G1")	

Step 3. After checking the water leaks and air purging, and then insulate water pipes.

- For venting, Install an air vent on the highest point of the water connection between outdoor and indoor unit.

NOTE

Make sure that the water pipes are protected from freezing in case of heat pump failure or power outage (e.g. Anti-freeze valve, that drains the water if temperature drops too much).

Wiring Procedure for Power Cable and Connecting Cable

This cable is generally connected between external power source (such as main electric power distribution panel of user's house) and the unit. Before starting wiring, check if wire specification is suitable and read following directions and cautions VERY carefully.

⚠ CAUTION

The Power cord connected to the unit should be selected according to the following specifications.

Step 1. : Disassemble side panel and front panel from the unit by loosening screws.

Step 2. : Connect power cable to main power terminal

See below figure for detailed information. When connecting earth cable, the diameter of cable should refer to the below table. The earth cable is connected to the Control box case where earth symbol is \perp marked.

Step 3. : Use cable clamps (or cord clamps) to prevent unintended move of power cable.

Step 4. : Reassemble the side panel to the unit by fastening screws.

(For Split)

U36A Chassis

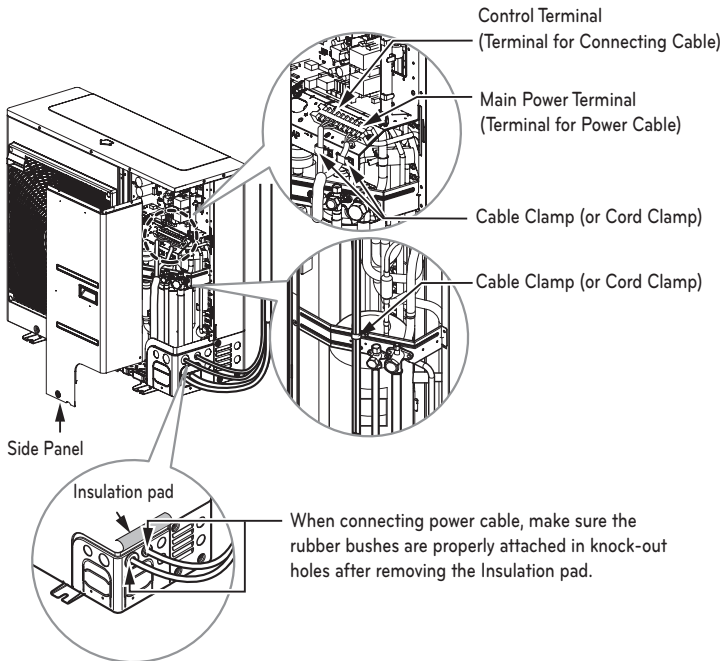

(For Hydrosplit)
U60A Chassis

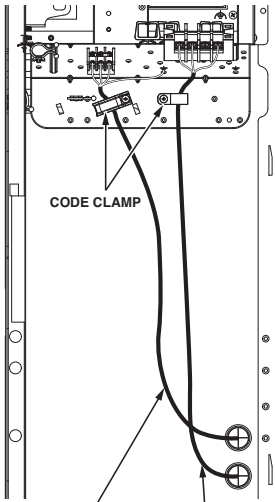
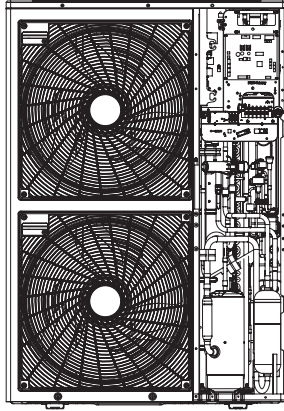

LOW VOLTAGE UNIT POWER
U60A (1Ø : 12, 14, 16 kW)

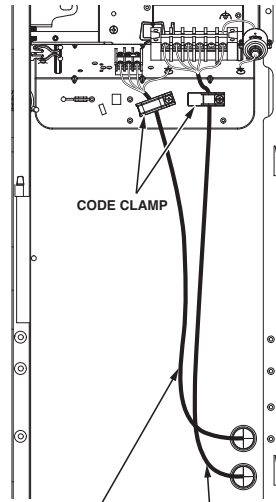

LOW VOLTAGE UNIT POWER
U60A (3Ø : 12, 14, 16 kW)

Failure to do these instruction can result in fire, electric shock or death.

- Make sure the power cable do not touch to copper tube.
- Make sure to fix [cord clamp] firmly to sustain the connection of terminal.
- Make sure to connect unit power & heater power separately.

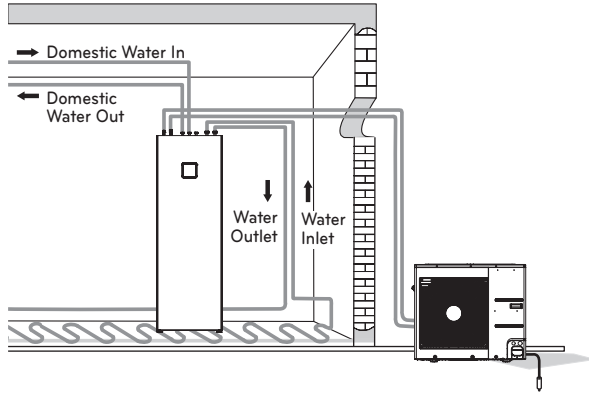

⚠ CAUTION

After checking and confirming following conditions, start wiring work.

- Secure dedicated power source for the Air-to-Water heat pump. The wiring diagram (attached inside the control box of the indoor unit) is presenting related information.
- Provide a circuit breaker switch between power source and the outdoor unit.
- Although it is very rare case, sometimes the screws used to fasten internal wires can be loosen due to the vibration while product transportation. Check these screws and make it sure if they are all fastened tightly. If not tightened, burn-out of the wire can be occurred.
- Check the specification of power source such as phase, voltage, frequency, etc.
- Confirm that electrical capacity is sufficient.
- Be sure that the starting voltage is maintained at more than 90 percent of the rated voltage marked on the name plate.
- Confirm that the cable thickness is as specified in the power sources specification. (Particularly note the relation between cable length and thickness.)
- Provide an ELB(earth leakage breaker) when the installation place is wet or moist.
- The following troubles would be caused by abnormal voltage supply such as sudden voltage increasing or voltage drop-down.
 - Chattering of a magnetic switch. (frequent on and off operation.)
 - Physical damage of parts where magnetic switch is contacted.
 - Break of fuse.
 - Malfunction of overload protection parts or related control algorithms.
 - Failure of compressor start up.
- Ground wire to ground outdoor unit to prevent electrical shock.

Finalizing (For Split)

After pipes are connected and electric cables are wired, pipe forming and some tests are remained. Especially, careful attention is required while proceeding leakage test because the leakage of the refrigerant effects degrade of performance directly. Also, it is very hard to find leaked point after all installation procedures are finished.

1. Pipe Forming

Do pipe forming by wrapping the connecting cable and refrigerant pipe (between the indoor unit and outdoor unit) with thermal insulation material and secure it with two kinds of vinyl tape.

- Tape the refrigerant pipe, power cable and connecting cable from down to up.
- Secure the taped pipe is along with the exterior wall. Form a trap to prevent water entering the room and electrical part.
- Fix the taped pipe onto the wall by saddle or equivalent.

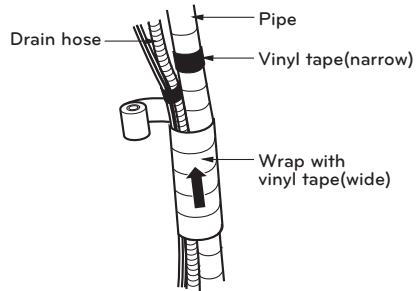

2. Taping Procedure

- Tape the pipes, connecting cable and power cable from down to up. If taping direction is up to down, rain drop may be sinking into the pipes or cables.
- Secure the taped pipe along the exterior wall using saddle or equivalent.
- Trap is required to prevent water from entering into electrical parts.

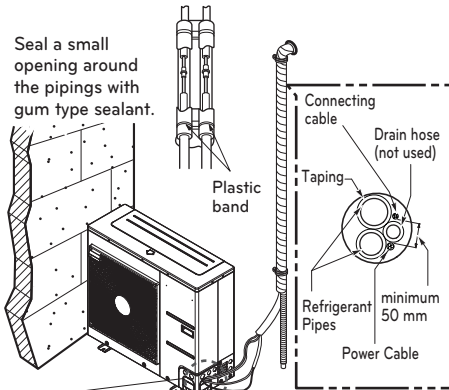

- Trap is required to prevent water from entering into electrical parts.

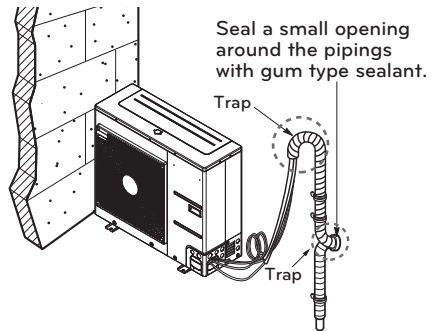

* Outdoor unit figure is a representative model U36A chassis.

Finalizing (For Hydrosplit)

1. Condensate drainage

The condensate water must be drained in a way that no ice can built-up and block the drainage pipe. Prepare a gravel bed below the foundation and drain the water to the ground - below frost line. Alternative option (if ODU is installed next to the wall), is to drain the water into the building. In that case, the pipe must have an angle of more than 5%. Only in regions without longer periods of frost, it is acceptable to drain straight to the ground. The drainage pipe should have a suitable diameter (~ DN50).

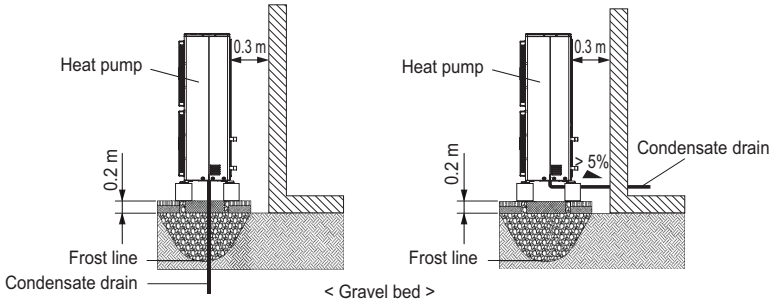

2. Electrical connection

Weather-proof cables must be used (e.g. NYY-type). It is recommended to protect the wires additionally by using a ductwork (rigid or flexible hose). Refer to the installation example cases below.

- Case1, pre-insulated pipes are used that includes ductwork for power and sensor cables.
- Case2, the heating pipes and the wires are lead through the same ductwork.

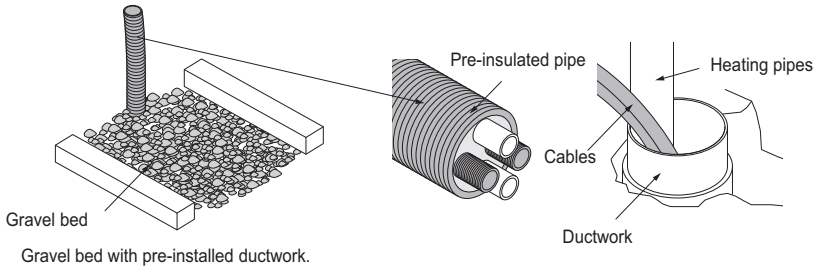

3. Heating pipes

The pipes must be insulated well. If the heat pump is used for heating and cooling, make sure that the insulation material is suitable for cooling operation.

If the pipes do not enter the building straight away (ODU installed at wall), the piped must be led through the ground below frost line. Make sure that the water pipes are protected from freezing in case of heat pump failure or power outage (e.g. Anti-freeze valve, that drains the water if temperature drops too much). Flexible hoses should be used to connect the outdoor installation with the building pipework (noise de-coupling). If the pipes (and cables) enter the building below the surface, make sure that no water can enter the building (e.g. by using a water-proof sealing).

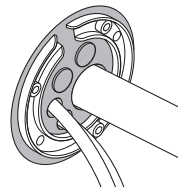

Water-proof sealing

Leakage test and Evacuation (For Split IWT)

Air and moisture remaining in the refrigerant system have undesirable effects as indicated below.

- Pressure in the system rises.
- Operating current rises.
- Cooling(or heating) efficiency drops.
- Moisture in the refrigerant circuit may freeze and block capillary tubing.
- Water may lead to corrosion of parts in the refrigeration system.

Therefore, the indoor/outdoor unit and connecting tube must be checked for leak tight, and vacuumed to remove incondensable gas and moisture in the system.

Preparation

- Check that each tube(both liquid and gas side tubes) between the indoor and outdoor units have been properly connected and all wiring for the test run has been completed. Remove the service valve caps from both the gas and the liquid side on the outdoor unit. Check that both the liquid and the gas side service valves on the outdoor unit are kept closed at this stage.

Leakage test

- Connect the manifold valve(with pressure gauges) and dry nitrogen gas cylinder to this service port with charge hoses.

CAUTION

Be sure to use a manifold valve for leakage test. If it is not available, use a stop valve for this purpose. The "Hi" knob of the manifold valve must always be kept close.

- Pressurize the system to no more than 3.0 MPa with dry nitrogen gas and close the cylinder valve when the gauge reading reached 3.0 MPa Next, test for leaks with liquid soap.

To avoid nitrogen entering the refrigerant system in a liquid state, the top of the cylinder must be higher than its bottom when you pressurize the system. Usually, the cylinder is used in a vertical standing position.

- Do a leakage test of all joints of the tubing(both indoor and outdoor) and both gas and liquid side service valves. Bubbles indicate a leak. Be sure to wipe off the soap with a clean cloth
- After the system is found to be free of leaks, relieve the nitrogen pressure by loosening the charge hose connector at the nitrogen cylinder. When the system pressure is reduced to normal, disconnect the hose from the cylinder.

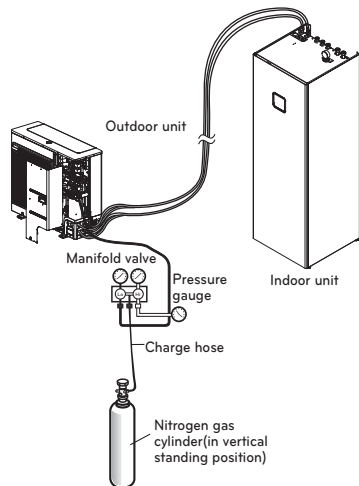

Evacuation

- Connect the charge hose end described in the preceding steps to the vacuum pump to evacuate the tubing and indoor unit. Confirm the "Lo and Hi" knob of the manifold valve is open. Then, run the vacuum pump. The operation time for evacuation varies with tubing length and capacity of the pump. The following table shows the time required for evacuation.

Required time for evacuation when 30 gal/h vacuum pump is used	
If tubing length is less than 10 m(33 ft)	If tubing length is longer than 10 m(33 ft)
30 min. or more	60 min. or more
0.8 torr or less	

- When the desired vacuum is reached, close the "Lo and Hi" knob of the manifold valve and stop the vacuum pump.

Finishing the job

- With a service valve wrench, turn the valve stem of liquid side valve counter-clockwise to fully open the valve.
- Turn the valve stem of gas side valve counter-clockwise to fully open the valve.
- Loosen the charge hose connected to the gas side service port slightly to release the pressure, then remove the hose.
- Replace the flare nut and its bonnet on the gas side service port and fasten the flare nut securely with an adjustable wrench. This process is very important to prevent leakage from the system.
- Replace the valve caps at both gas and liquid side service valves and fasten them tight. This completes air purging with a vacuum pump. The air to water heat pump is now ready to test run.

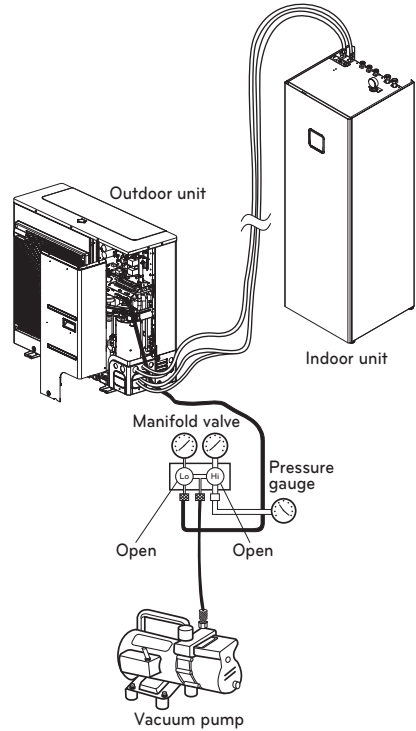

Electrical Wiring

General Consideration

Followings are should be considered before beginning indoor unit wiring.

- Field-supplied electrical components such as power switches, circuit breakers, wires, terminal boxes, etc should be properly chosen with compliance with national electrical legislation or regulation.
- Make it sure that supplied electricity is enough to operate the product including outdoor unit, electric heater, water tank heater, etc. The capacity of fuse also selected according to the power consumption.
- The main electricity supply should be dedicated line. Sharing main electricity supply with other devices such as washing machine or vacuum cleaner is not permitted.



CAUTION

- Before starting wiring job, the main electricity supply should be turned off until wiring is completed.
- When adjusting or changing wiring, the main electricity supply should be turned off and ground wire should be connected securely.
- Installation place should be free from the attack of wild animal. For example, mice's wire attacking or frog's entering into the indoor unit may cause critical electrical accident.
- All power connections should be protected from dew condensation by thermal insulation.
- All electrical wiring should comply with national or local electrical legislation or regulation.
- The ground should be connected exactly. Do not earth the product to the copper pipe, steel fence at the veranda, city water outlet pipe, or any other conductivity materials.
- Fix all cable using cord clamp tightly. (When cable is not fixed with cord clamp, use additionally supplied cable ties.)

Conduits for electrical wiring

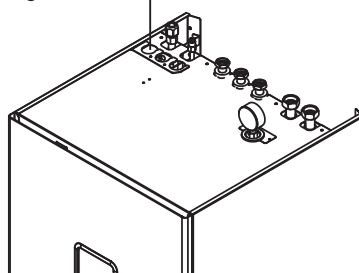

Terminal Block Information (For Split IWT)

Symbols used below pictures are as follows :

- L, L1, L2, L3 : Live (230 V AC)
- N : Neutral (230 V AC)
- BR : Brown , WH : White , BL : Blue , BK : Black

⚠ CAUTION

Before electric wiring, please check model name
 - Model : HN0916T NB1

Terminal Block 1

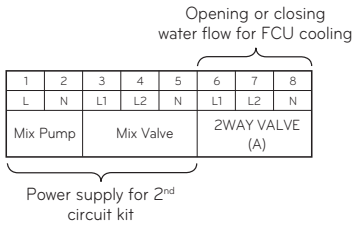

Terminal Block 2

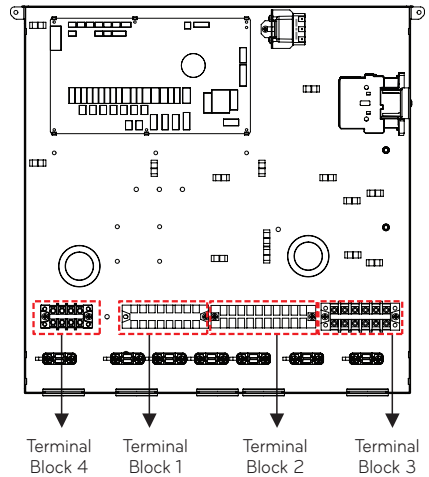
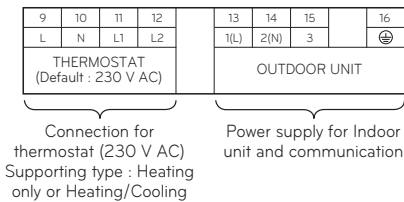

Terminal Block 3

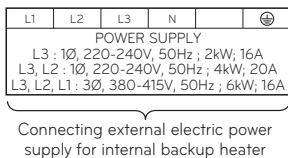

Terminal Block 4

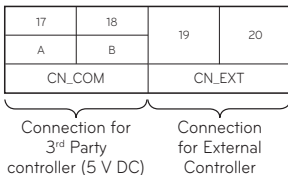

Terminal Block Information (For Hydrosplit IWT)

Symbols used below pictures are as follows :

- L, L1, L2, L3 : Live (230 V AC)
- N : Neutral (230 V AC)
- BR : Brown , WH : White , BL : Blue , BK : Black

⚠ CAUTION

Before electric wiring, please check model name
 - Model : HN1616Y NB1

Terminal Block 1

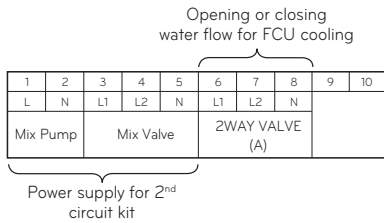

Terminal Block 2

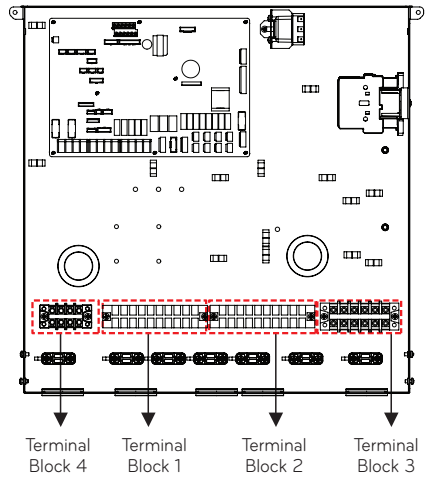
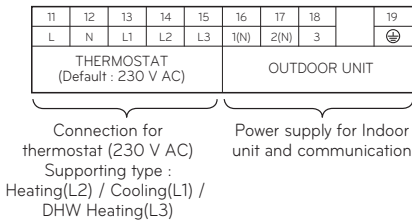

Terminal Block 3

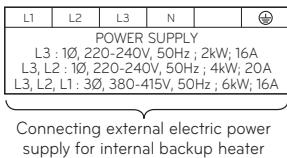

Terminal Block 4

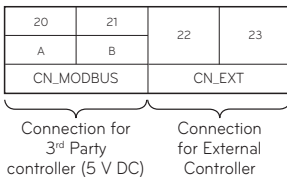

! CAUTION

You should separate the communication wiring, in case of communication wiring length is over 40 m.

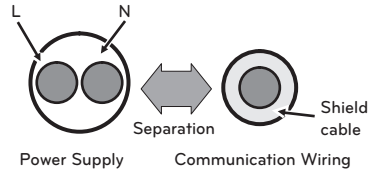

Connecting with Outdoor Unit

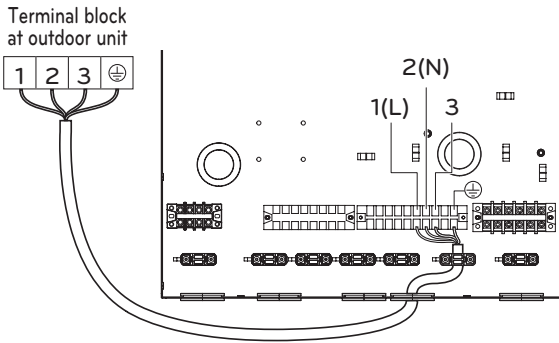

The feature may be changed according to the type of model.

Electric Heater Wiring

CAUTION

Power Cable Specification : The power cord connected to the electric heater should be complied with IEC 60245 or HD 22.4 S4(Rubber insulated cord, type 60245 IEC 66 or H07RN-F)

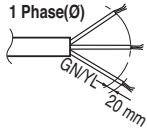

(For 2kW, 4kW)



Additional bridge Wire from L3 to L2

(For 4kW)

NORMAL CROSS-SECTIONAL AREA 4 mm²

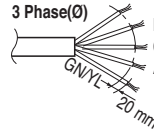

(For 6kW)

NORMAL CROSS-SECTIONAL AREA 2.5 mm²

If the supply cord is damaged, it must be replaced by the manufacturer, its service agent or similarly qualified persons in order to avoid a hazard.

External power supply

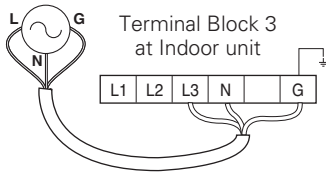

1Ø Electric Heater (2 kW)
- Input Fuse : 16 A

External power supply

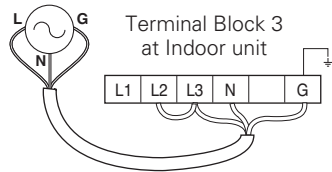

It is necessary to connect the bridge from **L3 to L2**

1Ø Electric Heater (4 kW)
- Input Fuse : 20 A

External power supply

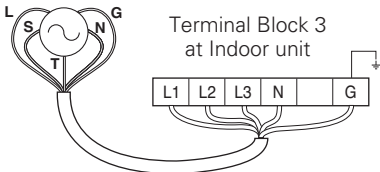

3Ø Electric Heater (6 kW)
- Input Fuse : 3 x 16 A

HYDRAULIC CONNECTION FOR INDOOR UNIT

Procedures about water piping at the indoor unit are described in this chapter.

General considerations, water piping, water charging, and pipe insulations will be shown for hydraulic connection procedures. The other accessories connection, such as DHW expansion vessel, buffer tank, thermostat, 2way valves, etc will be dealt in separated chapter.

General Considerations



CAUTION

Followings are should be considered before beginning water circuit connection.

- Service space should be secured.
- Water pipes and connections should be cleaned using water.
- Space for installing external water pump should be provided if internal water pump capacity is not enough for installation field.
- Never connect electric power while proceeding water charging.

Definition of terms are as follow :

- Water piping : Installing pipes where water is flowing inside the pipe.
- Water circuit connecting : Making connection between the product and water pipes or between pipes and pipes.

Connecting valves or elbows are, for example, in this category.

Configuration of water circuit is shown in Chapter 2.

All connections should be complied with presented diagram.

While installing water pipes, followings should be considered :

- While inserting or putting water pipes, close the end of the pipe with pipe cap to avoid dust entering.
- When cutting or welding the pipe, always be careful that inner section of the pipe should not be defective. For example, no weldments or no burrs are found inside the pipe.
- Drain piping should be provided in case of water discharge by the operation of the safety valve. This situation can be happened when the internal pressure is over 3.0 bar or water tank pressure is over 10.0 bar and then water inside the indoor unit will be discharged to drain hose.
- Recommended tightening torque is as following.

Size [inch]	Recommended tightening torque [N·m]
G 3/4"	36 ± 2
G 1"	42 ± 2

While connecting water pipes, followings should be considered:

- Pipe fittings (e.g. L-shape elbow, T-shape tee, diameter reducer, etc) should be tightened strongly to be free from water leakage.
- Connected sections should be leakage-proof treatment by applying teflon tape, rubber bushing, sealant solution, etc.
- Appropriate tools and tooling methods should be applied to prevent mechanical breakage of the connections.
- Operation time of flow control valve(e.g. 3way valve or 2way valve) should be less than 90 seconds.
- Drain hose should be connected with drain piping.
- Connect the water for filling or refilling the heating system as specified by EN 1717/EN 61770 to avoid contamination of drinking water by return flow.

**WARNING****Water condensation on the floor**

While cooling operation, it is very important to keep leaving water temperature higher than 16 °C. Otherwise, dew condensation can be occurred on the floor.

If floor is in humid environment, do not set leaving water temperature below 18 °C.

Water condensation on the radiator

While cooling operation, cold water may not flow to the radiator. If cold water enters to the radiator, dew generation on the surface of the radiator can be occurred.

Drainage treatment

While cooling operation, condensed dew can drop down to the bottom of the indoor unit. In this case, prepare drainage treatment (for example, vessel to contain condensed dew) to avoid water drop.

Connection to the Domestic hot water system

The hydraulic connection has to be installed in accordance with the national and local regulations for connecting buffer tanks for DHW to enable the water flow in full force. To prevent water leakage, install a drain through the floor below the level of the device. The following picture shows the correct hydraulic connection of the device.

Water Piping

Connect the hot water pipe ①, the cold water supply ② and optionally the re-circulation pipe ③ as shown below. If a re-circulation pipe is not used, close it with a $\frac{3}{4}$ " cap.

Use a counter wrench to tighten the connections firmly.

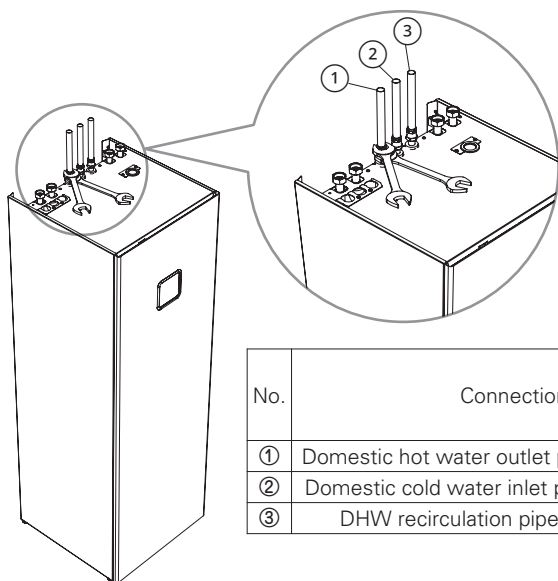

No.	Connections	Recommended tightening torque [N·m]
①	Domestic hot water outlet pipe (female G3/4")	36 ± 2
②	Domestic cold water inlet pipe (female G3/4")	
③	DHW recirculation pipe (female G3/4")	

NOTE

Before connect domestic water pipes, use the provided gaskets(G3/4") for each water pipe.

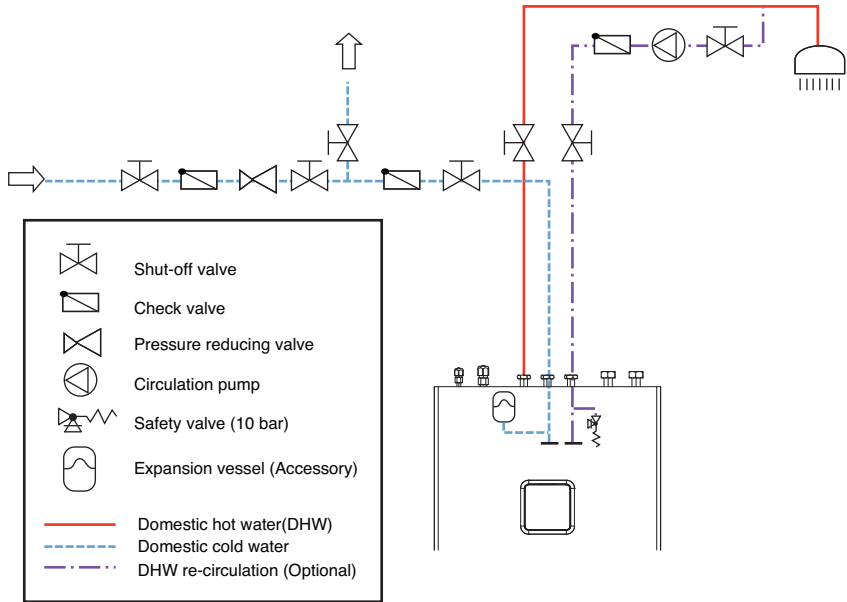

CAUTION

- Because different materials are used on the pipe installation, all connections on the device (cold and hot water, circulation, heat conductor) have to be galvanically isolated; otherwise corrosion of connections can occur on the inner side of the buffer tank for DHW. We recommend placing galvanic isolators made of red brass the length of at least twice the diameter of the pipe on the connections.
- The DHW tank is intended for storing drinking water, this is why the water has to be in accordance with the national regulations on drinking water in force; otherwise, damage to the device and a termination of the warranty can arise.
- The unit is equipped with a safety valve with a rated pressure of 1 MPa (10 bar).
- In addition, it is necessary to install either a DHW expansion vessel. Alternatively, another pressure relief valve must be installed with suitable set point lower than that of the safety valve. Such a valve would need to be equipped with a hose and connected to a sink.

Setting the pressure for the expansion vessel for DHW

NOTE

- The cold DHW connection must be fitted with an expansion vessel suitable for drinking water. The selection and installation must be in accordance with the standard DIN 4807 T5.
 - An expansion vessel of 8 l volume – that can be integrated into the unit - is available as accessory.
 - The actual size of the vessel must be decided by the installer. If a larger volume is needed, a third-party expansion vessel must be installed outside of the unit.
-
- For proper operation of the expansion vessel, a suitable setting of the vessels operating pressure must be made. The pressure is set in regards to the pressure in the DHW system. The setting needs to be checked every 12 months.
 - Expansion vessel for DHW is factory filled to a precharge pressure p_0 with dry nitrogen. The pressure must be set depending on the settings of the pressure reducing valve on the DHW supply to the building.
 - The pressure in the expansion vessel must be set according to the following formula:

$$p_0 = p_{rv} - 0,2 \text{ bar}$$

p_0 – pressure in the expansion vessel

p_{rv} – setting of the pressure reducing valve

Connection to the Heating system

The selection of circulation pumps, valves, safety elements and pipes has to be performed by the design engineer according to the heating/cooling capacity of the device and minimum water flow rate.

! CAUTION

- Before connecting the device, it is necessary to rinse the pipe system thoroughly and remove impurities. Use suitable detergents if necessary.
- Thorough venting of the system has to be ensured. Otherwise, malfunctions in operation may occur.

Water Piping

Assemble the supplied ball valves before connecting the Inlet ① and Outlet ② pipes. Use a counter wrench to tighten the connections firmly.

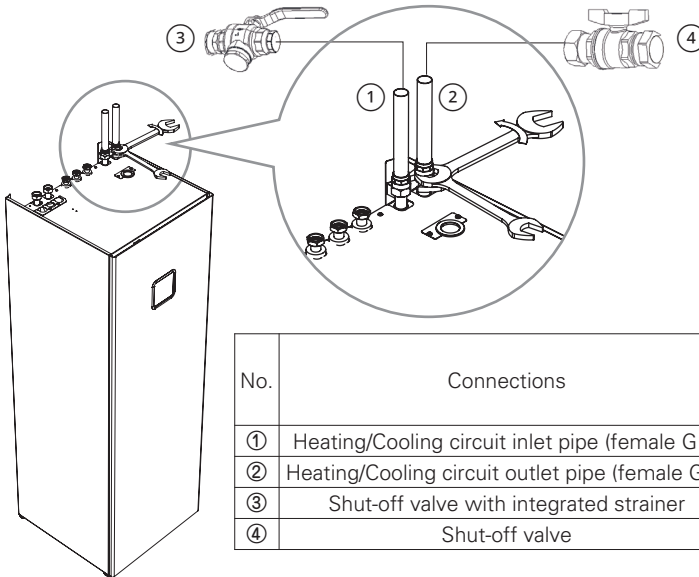

NOTE

Before connect heating water pipes, use the provided gaskets(G1") for each water pipe.

Water Volume and Expansion Vessel Pressure

- The expansion vessel must be dimensioned in accordance with standard EN 12828. The integrated vessel has a volume of 12 liters. If the expansion volume is not enough, and additional vessel must be installed externally (Field supply).
- A buffer tank of 40 liters is provided as accessory. The accumulator is needed for hydraulic balancing, ensuring unobstructed flow and defrosting.

CAUTION

- For normal operation of the expansion vessel, it is necessary to perform proper adjustments of the vessel's working pressure. The integrated vessel is supplied with a factory pre-charge of 0.75 bar. The settings have to be checked every 12 months.
- Consider the maximal operational pressure of the vessel.
- Unsuitable charge of the expansion vessel with the pressure p_0 is the reason for incorrect operation of the heating system.

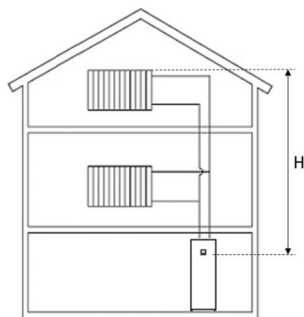

H - Height of the heating system
 p_{sv} - Pressure of the safety valve.

Setting the pressure for the expansion vessel p_0

- Before filling the system with water, check and set the pressure p_0 . The expansion vessel is factory set to the pressure specified on its data label. For correct operation of the system, set the pressure p_0 according to the equation below. The filling must not exceed the maximum operational pressure specified on the data label of the expansion vessel.
- Calculate the p_0 pressure value with the help of the equation:

$$p_0[\text{bar}] = H[\text{m}]/10 + 0,2 [\text{bar}]$$

$p_0[\text{bar}]$ – pressure in the expansion vessel

$p_{0min} [\text{bar}]$ – minimum allowable pressure of the heating system

$p_{0max} [\text{bar}]$ – maximum allowable pressure of the heating system

$H[\text{m}]$ – Height of the heating system (from expansion vessel to the highest heating body in the building).

If the calculation shows a pressure lower than 1 bar, set the pressure of the expansion vessel to 1 bar.

- Set the amount of pressure in the expansion vessel by releasing or adding dry nitrogen.
- Record the new value of the pressure p_0 on the data label.
- Open the closing valve of the expansion vessel carefully, open the vents and close the drain.

Water Charging

For water charging, please follow below procedures.

Step 1. Open all valves of whole water circuit. Supplied water should be charged not only inside the indoor unit, but also in the under floor water circuit, sanitary water tank circuit, FCU water circuit, and any other water circuits controlled by the product.

Step 2. Connect supply water into drain valve and fill valve located at the side of the shut-off valve.

CAUTION

No water-leakage permitted at the drain and fill valve. Leakage-proof treatment which is described in previous section should be applied.

Drain cock for draining the DHW tank

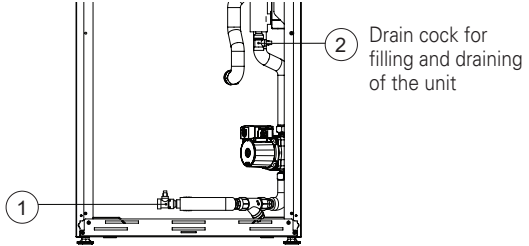

Step 3. Start to supply water. While supplying water, following should be kept.

- Pressure of supplying water should be 2.0 bar approximately.
- For supplying water pressure, time to be taken from 0 bar to 2.0 bar should be more than 1 minute. Sudden water supply can yield water drain through safety valve.
- Fully open the cap of air vent to assure air purging. If air is exist inside the water circuit, then performance degrade, noise at the water pipe, mechanical damage at the surface of electric heater coil.
- Open both the air vent in the water pipe and the air vent in the pump.

Step 4. Stop water supplying when the pressure gauge located in front of the control panel indicates 2.0 bar.

Step 5. Close drain valve and fill valve. Then wait for 20~30 seconds to observe water pressure being stabilized.

Step 6. If following conditions are satisfactory, then go to step 7(pipe insulation). Otherwise, go to step 3.

- Pressure gauge indicates 2.0 bar. Note that sometimes pressure is decreased after step 5 due to water charging inside expansion vessel.
- No air purging sound is heard or no water drop are popping out from air vent.

CAUTION

Keep the air vent of the water pipe open and keep the air vent of the pump closed. Otherwise, the pump may make noise.

Pipe Insulation

Purpose of water pipe insulation is :

- To prevent heat loss to external environment
- To prevent dew generation on the surface of the pipe in cooling operation
- Minimum insulation thickness recommendations ensure correct operation of the product, but local regulations may vary and must be followed.

Water Piping length (m)	Minimum insulation Thickness(mm)
<20	20
20~30	30
30~40	40
40~50	50

* $\lambda = 0.04 \text{ W/mk}$

Water pump Capacity

The water pump is variable type which is capable to change flow rate, so it may be required to change default water pump capacity in case of noise by water flow. In most case, however, it is strongly recommended to set capacity as Maximum.

NOTE

- To secure enough water flow rate, do not set water pump capacity as Minimum. It can lead unexpected flow rate error CH14.

Pressure Drop

NOTE

When installing the product, install additional pump in consideration of the pressure loss and pump performance.

If flow-rate is low, overloading of product can occur.

(For Split IWT)

Capacity [kW]	Rated flow-rate [LPM]	Pump Head [m] (at rated flow-rate)	Product pressure drop [m] (Plate heat exchanger)	Serviceable Head [m]
9	25.9	6.8	2.9	3.9
7	20.1	7.8	1.8	6.0
5	15.8	8.2	1.1	7.1

(For Hydrosplit IWT)

Capacity [kW]	Rated flow-rate [LPM]	Pump Head [m] (at rated flow-rate)	Product pressure drop [m] * (Plate heat exchanger)	Serviceable Head [m]
16	46.0	8.9	1.4	7.5
14	40.3	9.6	1.1	8.5
12	34.5	10.2	0.8	9.4

※ Above data is valid at Rated flow-rate with delta-temperature of 5 Kevin.

* Hydrosplit IWT should further consider the pressure drop depending on the length of indoor and outdoor piping.

Performance curve

5, 7, 9 kW / For Split IWT

Pump model (heating) : WILO Para KU 25-130/8-75/12 iPWM1

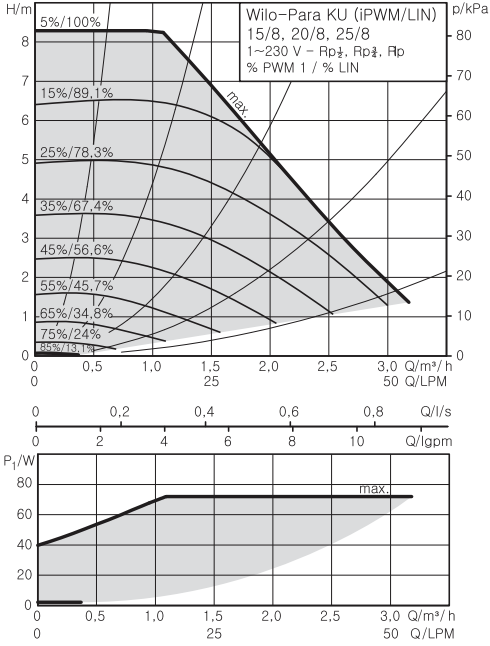

12, 14, 16 kW / For Hydrosplit IWT

Pump model (heating) : Grundfos UPML 25-105 130 PWM A

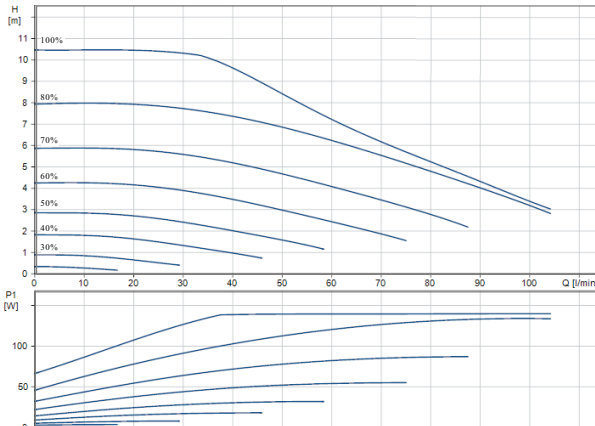

Pump model (DHW) : WILO ZRS 15/6-3 KU

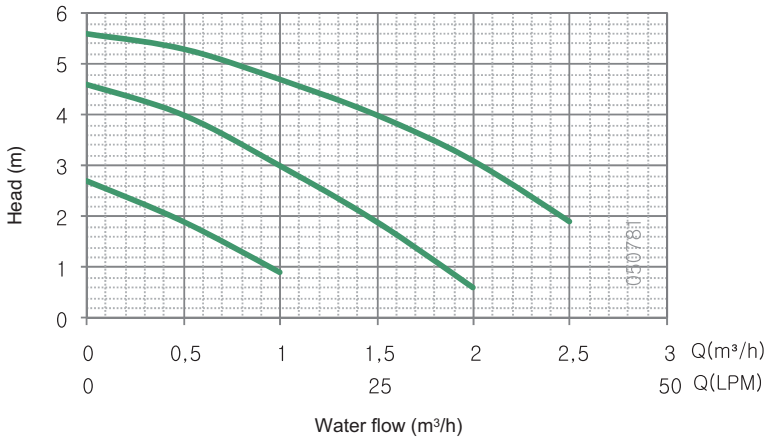

WARNING

Selecting a water flowrate outside the curves can cause damage to or malfunction of the unit.

Water Quality

Water quality should be complied with EN 98/83 EC Directives.
Detailed water quality condition can be found in EN 98/83 EC Directives.

CAUTION

- The heating system has to be filled with water with the hardness between 5 °dH and 10 °dH. Malfunctions of the device because of water hardness are not covered by the warranty.
- A galvanic disconnection between individual elements of the heating system is obligatory.
- In the case of using grey steel pipes in the heating system, it is necessary to degrease them (the interior of the pipe) before connecting them to the heat pump.
- The water in the heating system has to be in accordance with the requirements of standard VDI 2035 and must not contain microorganisms. Before filling, the heating system has to be cleaned of all impurities.
- The heating system has to be thoroughly vented. You must prevent air, including diffusion air entering the device.
- It is strongly recommended to install an additional filter on the heating water circuit. Especially to remove metallic particles from the heating piping, it is advised to use a magnetic or cyclone filter, which can remove small particles. Small particles may damage the unit and will NOT be removed by the standard filter of the heat pump system.

Frost protection

In areas of the country where entering water temperatures drop below 0 °C, the water pipe must be protected by using an approved antifreeze solution. Consult your AWHP unit supplier for locally approved solutions in your area. Calculate the approximate volume of water in the system. (Except the AWHP unit.) And add six liters to this total volume to allow for the water contained in AWHP unit.

Antifreeze type	Antifreeze mixing ratio					
	0 °C	-5 °C	-10 °C	-15 °C	-20 °C	-25 °C
Ethylene glycol	0 %	12 %	20 %	30 %	-	-
Propylene glycol	0 %	17 %	25 %	33 %	-	-
Methanol	0 %	6 %	12 %	16 %	24 %	30 %

If you use frost protection function, change DIP switch setting and input the temperature condition in Installation mode of remote controller.

CAUTION

- Use only one of the above antifreeze.
- If a antifreeze is used, pressure drop and capability degradation of the system can be occurred.
- If one of antifreezes is used, corrosion can be occurred. So please add corrosion inhibitor.
- Please check the concentration of the antifreeze periodically to keep same concentration.
- When the antifreeze is used (for installation or operation), take care to ensure that antifreeze must not be touched.
- Ensure to respect all laws and norms of your country about Anti-freeze usage.

ACCESSORIES INSTALLATION

THERMAV. can interface to various accessories to extend its functionality and to improve user convenience. In this chapter, specifications about supported 3rd party accessories and how to connect to **THERMAV.** is introduced.

The Product is designed to work with the following LG accessories. Regarding any other compatible accessories refer to Product Databook or ask your local dealer.

Accessories supported by LG Electronics

Item	Purpose	Model
Buffer Tank (40l)	For heating system - Integral at backside of unit	OSHB-40KT
DHW Expansion Vessel (8l)	For DHW system - Integrable inside of unit	OSHE-12KT
Dry contact	To receive on & off external signal	PDRYCB000
	Dry contact For Thermostat	PDRYCB320
Meter Interface	To measure production / consumption power	PENKTH000
Wi-Fi Modem	To enable remote system operation from smartphone	PWFMD200
Thermistor for 2 nd Circuit or E/heater	To interlock with 2 nd circuit operation and control temperature of main zone or To interlock with 3 rd party E/Heater and control temperature of water out 3 rd party E/Heater.	PRSTAT5K10
Extension Wire	To connect remote controller with Indoor PCB for communication	PZCWRC1
Cover Plate	To relocate remote controller from indoor unit	PDC-HK10
Remote air sensor	To control the unit using Room air as reference temperature	PQRSTA0
Extension cable	To extend Wi-Fi modem cable	PWYREW000
RS3 remote controller	To control unit with 2 remote controllers	PREMTW101
2-Remo Control Wire	The wire for 2 remo control	PZCWRC2
Central controller	To control and communicate the products	AC EZ Touch (PACEZA000) AC Smart 5 (PACS5A000) ACP 5 (PACP5A000) AC Manager 5 (PACM5A000)
ESS	To control the operation mode according to the energy storage state	(For Hydrosplit IWT) HOME 8 (PCS): D008KE1N211 HOME10(PCS): D010KE1N211 HB7H(Battery): BLGRESU7H HB10H(Battery): BLGRESU10H

Accessories supported by 3rd party Companies

Item	Purpose	Specification
Thermostat	To control by air temperature	<ul style="list-style-type: none"> • Heating-Only type (230 V AC) • Cooling/Heating type (230 V AC with Mode selection switch) • For Hydrosplit IWT, Heating / Cooling / DHW Heating type
Mix Kit	To use mixing circuit	<ul style="list-style-type: none"> • Mixing valve • Mix pump
3 rd Party Boiler	To use auxiliary boiler.	
3 rd Party Controller	To connect external controller using modbus protocol	
2way valve and actuator	To control water flow for Fan Coil Unit	2 wire,NO(Normal Open) or NC(Normal Closed) type, 230 V AC
External Pump	To control the water flow at the rear of the buffer tank	
Smart Grid	To control operation mode depending on input signal from provider	
3 rd Party ESS	To control the operation mode according to the energy storage state	For Hydrosplit IWT

Before Installation



WARNING

Followings should be kept before installation

- Main power must be turned off during installing accessories.
- 3rd party accessories should be comply with supported specification.
- Proper tools should be chosen for installation.
- Never do installation with wet hands.

Domestic hot water expansion vessel – integrated into the unit

How to install DHW expansion vessel [OSHE-12KT]

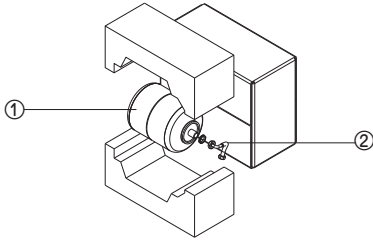

- ① DHW expansion vessel
- ② Connection pipe

Step 1. The vessel is delivered with a connection pipe(①). Screw the pipe to the dedicated port(③) inside of the unit.

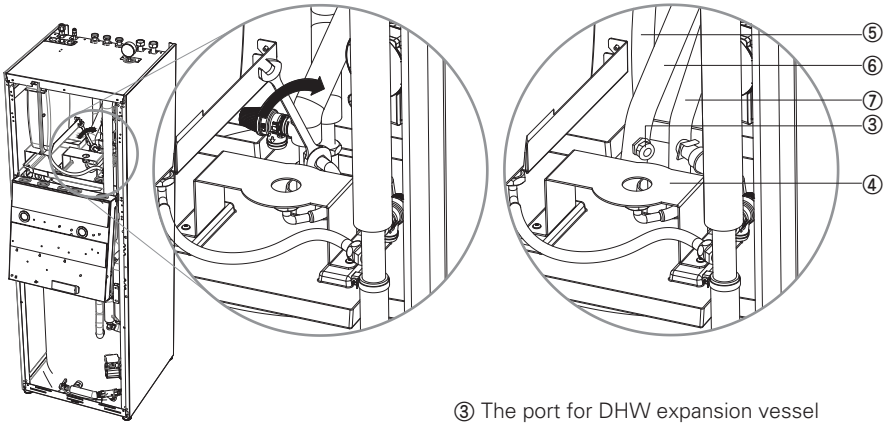

- ③ The port for DHW expansion vessel
- ④ The Holder for DHW expansion vessel
- ⑤ Domestic hot water outlet pipe
- ⑥ Domestic cold water inlet pipe
- ⑦ DHW Re-circulation pipe

Step 2. Place the vessel (①) on top of the holder (④) and fasten the connection pipe from below.

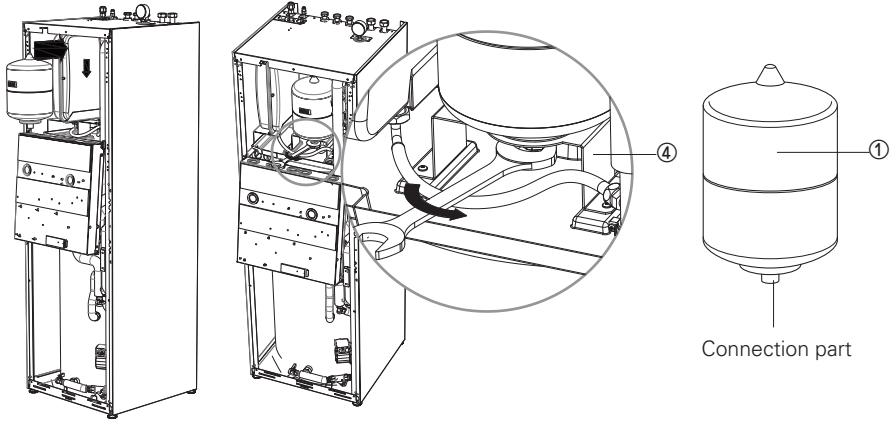

Buffer tank – integrated into the unit

How to install Buffer tank [OSHB-40KT]

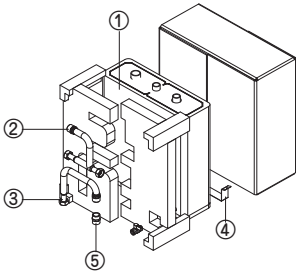

- ① Insulated buffer tank
- ② Outlet pipe assembly
- ③ Inlet pipe assembly
- ④ Buffer tank holder
- ⑤ Double nipple 1''

Step 1. Attach the buffer tank at the backside of the indoor unit and secure the provided holder with one screw on each side.

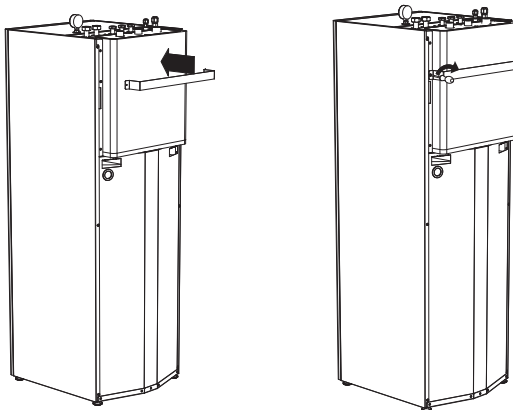

Step 2. Use the Shut-off valve with strainer supplied with the indoor unit and mount it to the inlet pipe assembly. Then screw the double nipple to the bottom part of the valve.

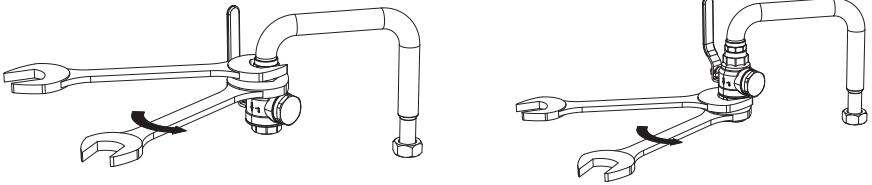

Then, attach the assembly as shown in the picture.

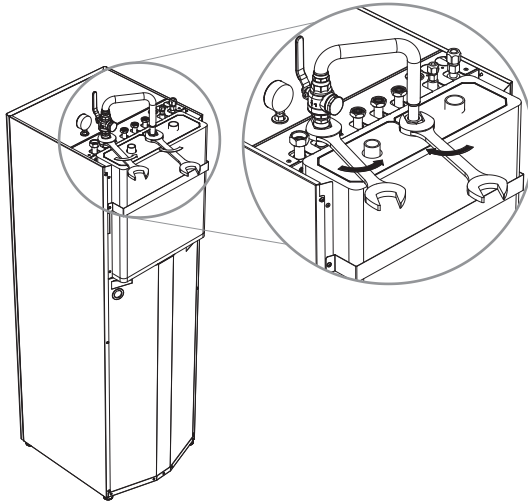

Step 3. Connect the outlet pipe assembly and the Shut-off valve – provided with the indoor unit – as shown below.

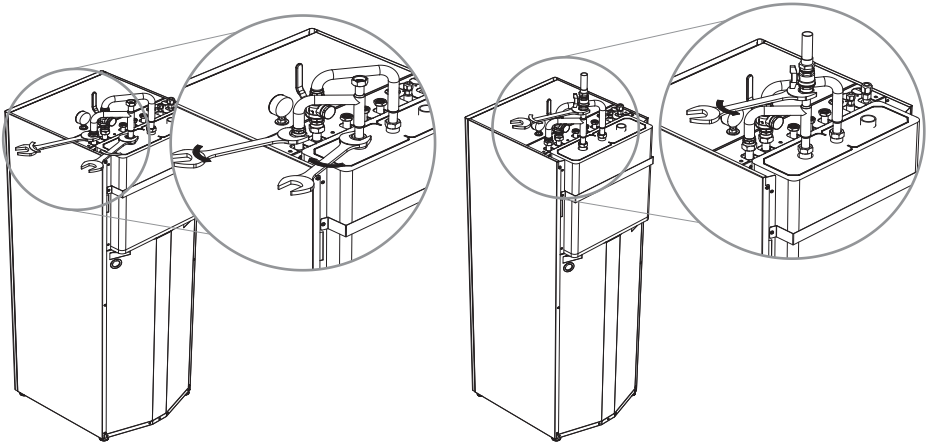

Step 4. Finally, assemble the Return pipe from the Heating system at the free connector.

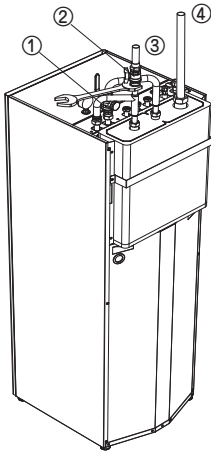

- ① Shut-off valve with strainer
- ② Shut-off valve
- ③ Outlet pipe
- ④ Inlet pipe

Thermostat

Thermostat is generally used to control the product by air temperature. When thermostat is connected to the product, the product operation is controlled by the thermostat.

Installation condition

! CAUTION

- USE 220-240 V~ Thermostat
- Some electro-mechanical type thermostat has internal delay time to protect compressor. In that case, mode change can takes time more than user's expectation. Please read thermostat manual carefully if the unit does not response quickly.
- Setting temperature range by thermostat can be different with that of the unit. The heating or cooling set temperature should be chosen within the setting temperature range of the unit.
- It is highly recommended that the thermostat should be installed where space heating is mainly applied.

Following location should be avoid to secure proper operation :

- Height from floor is approximately 1.5 m.
- Thermostat can not be located where the area may be hidden when door is open.
- Thermostat can not be located where external thermal influence may be applied. (such as above heating radiator or open window)

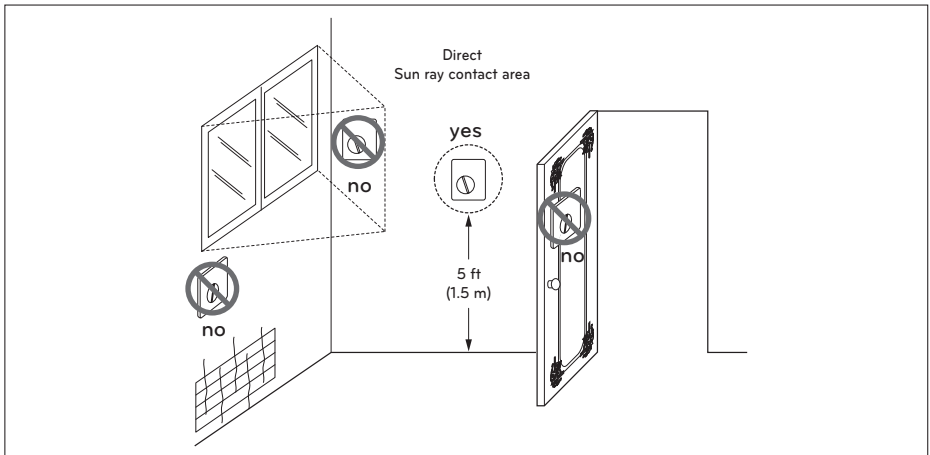

Thermostat

General Information

The Heat Pump supports following thermostats.

Type	Power	Operating Mode	Supported
Mechanical (1)	230 V~	Heating Only (3)	Yes
		Heating / Cooling (4)	
		Heating / Cooling / DHW Heating (5)	
Electrical (2)	230 V~	Heating Only (3)	Yes
		Heating / Cooling (4)	
		Heating / Cooling / DHW Heating (5)	

- (1) There is no electric circuit inside the thermostat and electric power supply to the thermostat is not required.
- (2) Electric circuit such as display, LED, buzzer, etc is included in the thermostat and electric power supply is required.
- (3) Thermostat generates "Heating ON or Heating OFF" signal according to user's heating target temperature.
- (4) Thermostat generates both "Heating ON or Heating OFF" and "Cooling ON or Cooling OFF" signal according to user's heating and cooling target temperature.
- (5) For Hydrosplit IWT, Thermostat generates "Heating ON or Heating OFF", "Cooling ON or Cooling OFF", "DHW Heating ON or DHW Heating OFF" signal according to user's heating, cooling and DHW heating target temperature.

CAUTION

Choosing heating / cooling thermostat

- Heating / cooling thermostat must have "Mode Selection" feature to distinguish operation mode.
- Heating / cooling thermostat must be able to assign heating target temperature and cooling target temperature differently.
- If above conditions are not kept, the unit can not operation properly.
- Heating / cooling thermostat must send cooling or heating signal immediately when temperature condition is satisfied. No delay time while sending cooling or heating signal is permitted.

How to wire thermostat (For Split IWT)

Follow below procedures Step 1 ~ Step 5.

Step 1. Uncover front cover of the unit and open the control box.

Step 2. Identify the power specification of the thermostat. If it is 220-240 V~, go to Step 3.

Step 3. If it is Heating only thermostat, go to step 4. Otherwise, if it is Heating / cooling thermostat, go to step 5.

Step 4. Find terminal block and connect wire as below. After connecting, go to final check step.

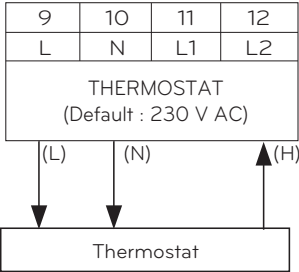

! WARNING

Mechanical type thermostat.

Do not connect wire (N) as mechanical type thermostat does not require electric power supply.

! CAUTION

Do not connect external electric loads.

Wire (L) and (N) should be used only for operation electric type thermostat.

Never connect external electric loads such as valves, fan coil units, etc. If connected, Main PCB (Heater) can be seriously damaged.

(L) : Live signal from PCB to thermostat

(N) : Neutral signal from PCB to thermostat

(H) : Heating signal from thermostat to PCB

Step 5. Find terminal block and connect wire as below.

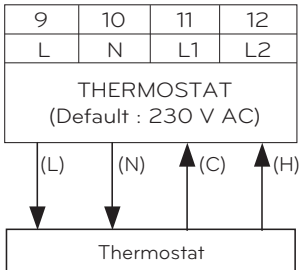

! WARNING

Mechanical type thermostat.

Do not connect wire (N) as mechanical type thermostat does not require electric power supply.

! CAUTION

Do not connect external electric loads.

Wire (L) and (N) should be used only for operation Electric type thermostat.

Never connect external electric loads such as valves, fan coil units, etc. If connected, Main PCB (Heater) can be seriously damaged.

(L) : Live signal from PCB to thermostat

(N) : Neutral signal from PCB to thermostat

(C) : Cooling signal from thermostat to PCB

(H) : Heating signal from thermostat to PCB

How to wire thermostat (For Hydrosplit IWT)

Follow below procedures Step 1 ~ Step 3.

Step 1. Uncover front cover of the unit and open the control box.

Step 2. Identify the power specification of the thermostat. If it is 220-240 V~, go to Step 3.

Step 3. Find terminal block and connect wire as below.

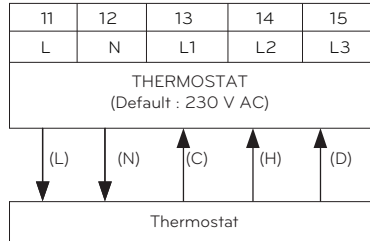

⚠ WARNING

Mechanical type thermostat.

Do not connect wire (N) as mechanical type thermostat does not require electric power supply.

⚠ CAUTION

Do not connect external electric loads.

Wire (L) and (N) should be used only for operation electric type thermostat.

Never connect external electric loads such as valves, fan coil units, etc. If connected, Main PCB (Heater) can be seriously damaged.

(L) : Live signal from PCB to thermostat

(N) : Neutral signal from PCB to thermostat

(C) : Cooling signal from thermostat to PCB

(H) : Heating signal from thermostat to PCB

(D) : DHW Heating signal from thermostat to PCB

Final check

- DIP switch setting :
Set DIP switch No. 8 to 'ON'. Otherwise, the unit can not recognize the thermostat.
- Remote Controller :
 - 'Thermostat' text is displayed on the remote controller.
 - Button input is prohibited.

2nd Circuit

The 2nd circuit is a function that can separately control the circuit1 requiring high temperature and the circuit 2 requiring medium temperature, you need to prepare a separate Mix Kit. The mix kit must be installed in the circuit 2.

For Split IWT

[Install Guide Mixing circuit [Install Guide Mixing circuit Heating]]

Circuit 1 \ Circuit 2	Floor (35°C)	Convector (FCU, 45 °C)	Radiator (45 °C)	Radiator (55 °C)
Floor (35 °C)	○	X	X	X
Convector (FCU, 45 °C)	○	○	○	X
Radiator (45 °C)	○	○	○	X
Radiator (55 °C)	○	○	○	○

[Install Guide Mixing circuit Cooling]

Circuit 1 \ Circuit 2	Floor (18 °C)	Convector (FCU, 5 °C)
Floor (18 °C)	○	X
Convector (FCU, 5 °C)	○	○

- ※ To use a floor combination during cooling operation, the flow through the floor of the flow must be blocked by the 2 way valve.
- ※ For detailed 2nd circuit remote control settings, refer to 'Mixing circuit(For split IWT)' under [Chapter 9]

NOTE

Circuit 1 = Direct circuit : Zone where the water temperature is Highest when heating

Circuit 2 = Mixing circuit : The other zone

The 2nd circuit is a function that can separately control the circuit1 requiring high temperature and the circuit 2 requiring medium temperature, you need to prepare a separate Mix Kit. The mix kit must be installed in the circuit 2.

For Hydrosplit IWT

[Install Guide Mixing circuit [Install Guide Mixing circuit Heating]]

Circuit 1 \ Circuit 2	Floor (35°C)	Convactor (FCU, 45 °C)	Radiator (45 °C)	Radiator (55 °C)
Floor (35 °C)	○	○	○	○
Convactor (FCU, 45 °C)	○	○	○	○
Radiator (45 °C)	○	○	○	○
Radiator (55 °C)	○	○	○	○

[Install Guide Mixing circuit Cooling]

Circuit 1 \ Circuit 2	Floor (18 °C)	Convactor (FCU, 5 °C)
Floor (18 °C)	○	○
Convactor (FCU, 5 °C)	○	○

* To use a floor combination during cooling operation, the flow through the floor of the flow must be blocked by the 2 way valve.

* For detailed 2nd circuit remote control settings, refer to 'Mixing Circuit(For Hydrosplit IWT)' under [Chapter 9]

NOTE

Circuit 1 = Direct circuit : Zone where the water temperature is Highest when heating

Circuit 2 = Mixing circuit : The other zone

How to Wire Mixing Kit (For Split IWT)

Follow below procedures Step 1 ~ Step 3.

Step 1. Uncover front cover of the unit.

Step 2. Find terminal block and connect wire as below

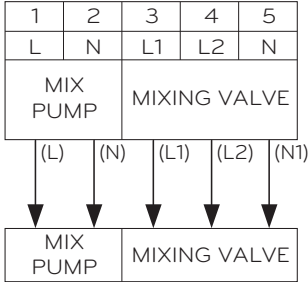

(L) : Live signal from PCB to mix pump

(N) : Neutral signal from PCB to mix pump

(L1) : Live signal (for Normal* Closed type) from PCB to mixing valve

(L2) : Live signal (for Normal Open type) from PCB to mixing valve

(N1) : Neutral signal from PCB to mixing valve

*Closed = NOT Mixed

Step3. Insert the temperature sensor to 'CN_MIX_OUT' (Brown) of the main PCB as shown below. The sensor should be mounted correctly to discharge pipe of mix pump as shown below.

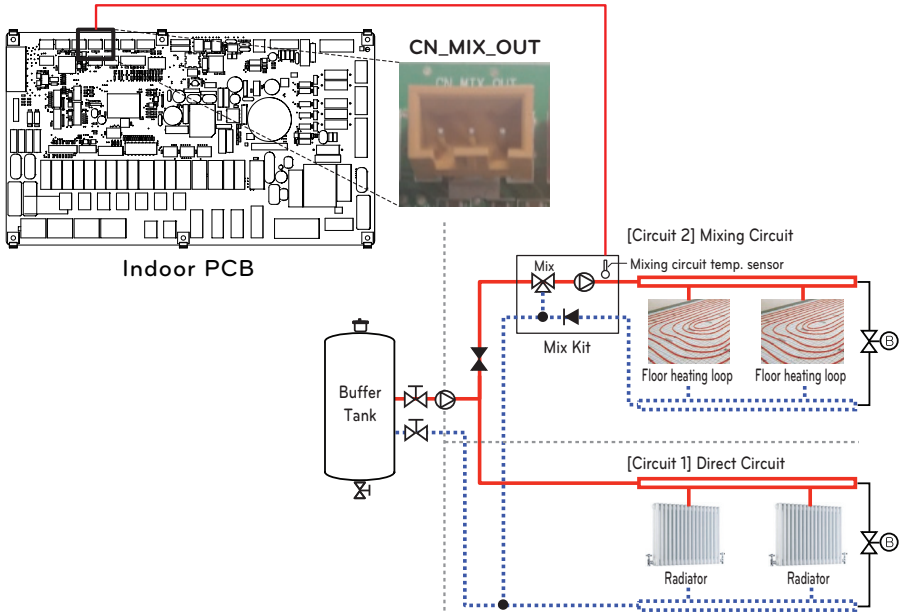

NOTE

- Temperature sensor specification:
 - Type : Thermistor, NTC
 - Resistance at 25 °C : 5 kΩ
 - Minimum operating temperature range : -30 °C~100 °C

How to Wire Mixing Kit (For Hydrosplit IWT)

Follow below procedures Step 1 ~ Step 3.

Step 1. Uncover front cover of the unit.

Step 2. Find terminal block and connect wire as below

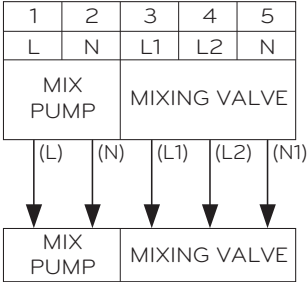

(L) : Live signal from PCB to mix pump

(N) : Neutral signal from PCB to mix pump

(L1) : Live signal (for Normal* Closed type) from PCB to mixing valve

(L2) : Live signal (for Normal Open type) from PCB to mixing valve

(N1) : Neutral signal from PCB to mixing valve

*Closed = NOT Mixed

Step3. Insert the temperature sensor to 'CN_MIX_OUT' (Brown) of the main PCB as shown below. The sensor should be mounted correctly to discharge pipe of mix pump as shown below.

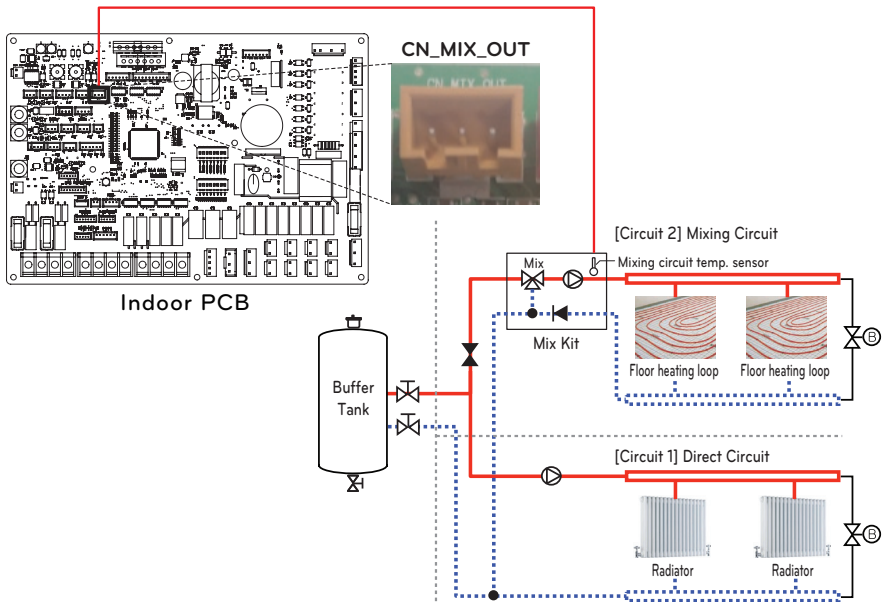

NOTE

- The location of the external pump may vary depending on the installer settings.
- Temperature sensor specification:
Type : Thermistor, NTC
Resistance at 25 °C : 5 kΩ
Minimum operating temperature range : -30 °C~100 °C

[Thermistor for Mixing circuit]



Sensor



Sensor Holder



Sensor Connector

Follow below procedures step 1 ~ step 4.

Step 1. Install sensor connector to discharge pipe of mix pump.

(Welding must be performed to connect the sensor connector to the pipe)

Step 2. Check if the power of the unit is turned off.

Step 3. Fasten the sensor connector to the sensor holder as shown in the figure below.

Step 4. Insert harness into PCB(CN_MIX_OUT) fully and fix the thermal sensor into tube connector as shown below.

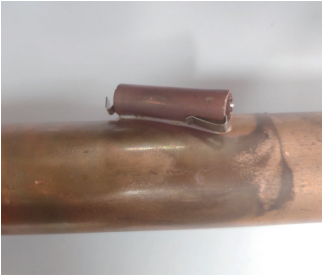

3rd Party Boiler

The product can be used by connecting an Auxiliary boiler. 3rd party boiler can be controlled by manually via RS3 remote controller or automatically itself by means of comparing the outside air temperature and the preset temperature.

How to wire 3rd party boiler

Follow below procedures step 1 ~ step 3.

Step 1. Check if the power of the unit is turned off.

Step 2. Disassemble front panels and Distinguish terminal block in Indoor PCB.

Step 3. Connect Power cable to terminal block fully.

(For Split IWT)

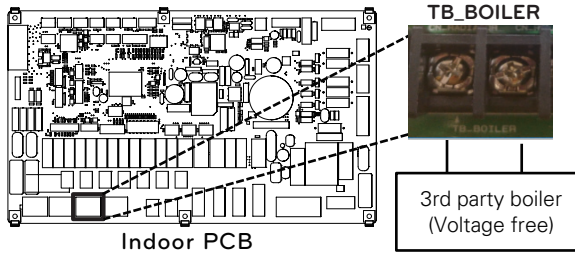

(For Hydrosplit IWT)

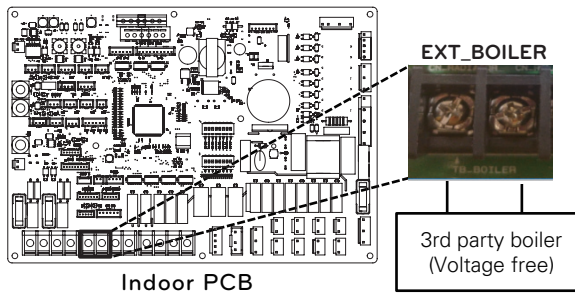

3rd Party Controller

The product can also be linked to 3rd party controller. You can connect external controllers using Modbus protocol except for LG controller. If 3rd party controller is used, LG controller is not applied to AWHP simultaneously.

How to wire 3rd party controller

Follow below procedures step 1 ~ step 4.

Step 1. Check if the power of the unit is turned off.

Step 2. Disassemble front panels and distinguish control box(Indoor) of the unit.

Step 3. Check if the harness(White) is inserted fully to the indoor unit PCB.

Step 4. Connect the 3rd party controller to terminal block 4 completely. (including Meter interface module)

(For Split IWT)

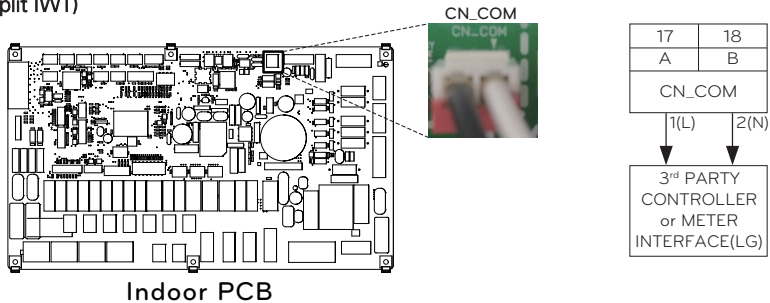

(For Hydrosplit IWT)

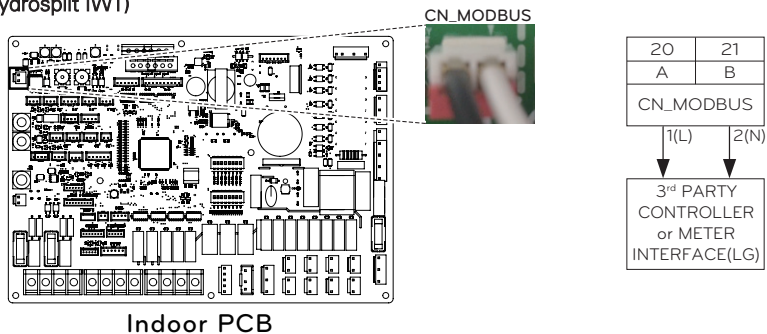

Meter Interface

This product can be used by connecting the meter interface module supplied in the field. The meter interface module can communicate with the wired remote controller. The meter interface module lets you know the amount of power generated by the product.

- For detailed installation method refer to meter interface Installation Manual.

How to wire Meter Interface

[Parts of Meter interface]

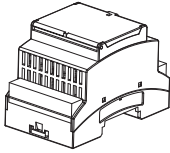

Meter interface body

Follow below procedures step 1 ~ step 4.

Step 1. Check if the power of the unit is turned off.

Step 2. Disassemble front panels and Distinguish control box(Indoor) of the unit.

Step 3. Check if the harness(White) is inserted fully to the indoor unit PCB.

Step 4. Connect the external pump to terminal block 4.

(For Split IWT)

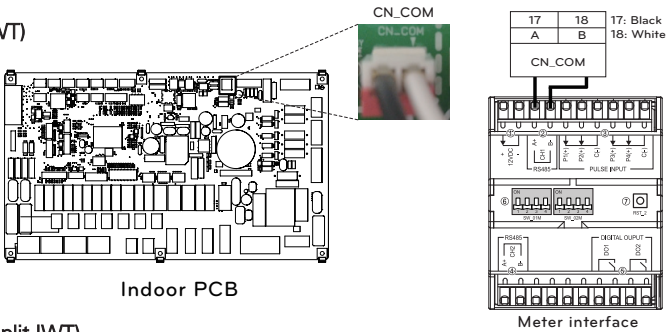

(For Hydrosplit IWT)

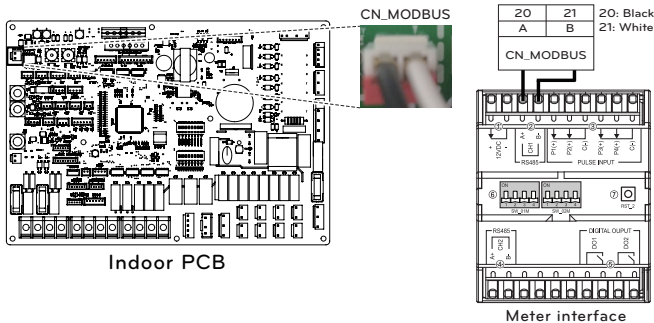

Central Controller

The product can communicate and control through the central controller. The following functions can be controlled in the central control linked state (Operation/Stop, Desired temperature, Hot water operation / stop, Warm water temperature, Full lock, Etc)

LG Central controller

Item	Purpose	Model
ACP 5	To control AWHP using LG central controller	PACEZA000
AC Smart 5		PACS5A000
ACP Ez Touch		PACP5A000

Accessories for Central controller

Item	Purpose	Model
PI485 Gateway	To connect LG Central Controller / Modbus	PMNFP14A1
Modbus RTU Gateway	To communicate and control BMS / 3 rd party controller directly.	PMBUSB00A

NOTE

- PI485 is required for central controller.
- For Hydrosplit IWT, When Modbus protocol is used, PI485 and Modbus RTU Gateway are not required.

How to Installation PI485

Fix the PI485 PCB as shown in below images.

For detailed installation method refer to PI485 Installation Manual

Product Heating Capacity : 12 kW, 14 kW, 16 kW

U60A Chassis

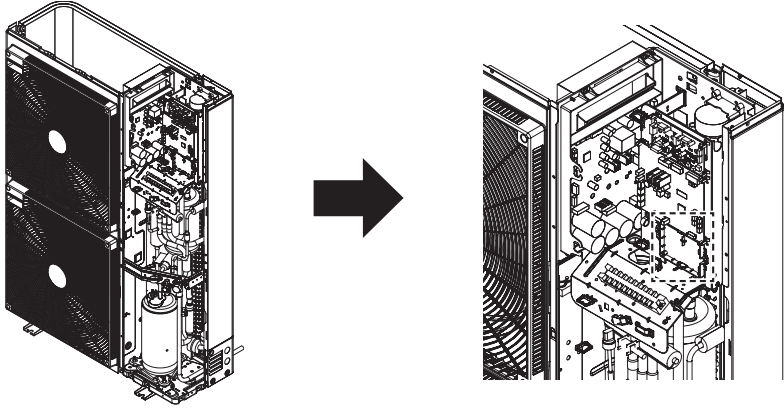

Product Heating Capacity : 5 kW, 7 kW, 9 kW

U36A Chassis

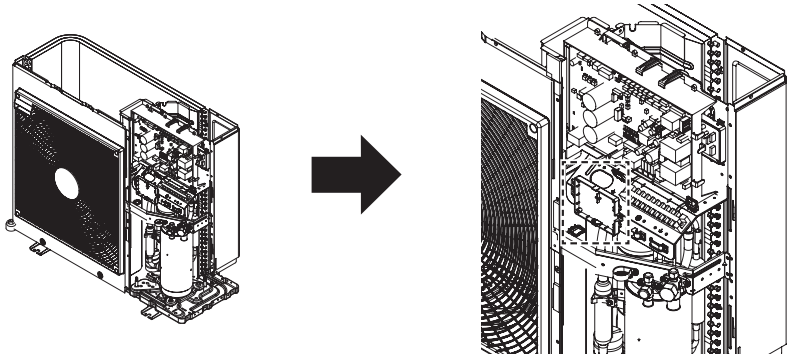

- For detailed installation instructions, refer to the manual included in the accessories.

How to Installation Modbus gateway

Connect the Modbus gateway as shown in below diagram.

For detailed installation method refer to Modbus gateway Installation Manual.

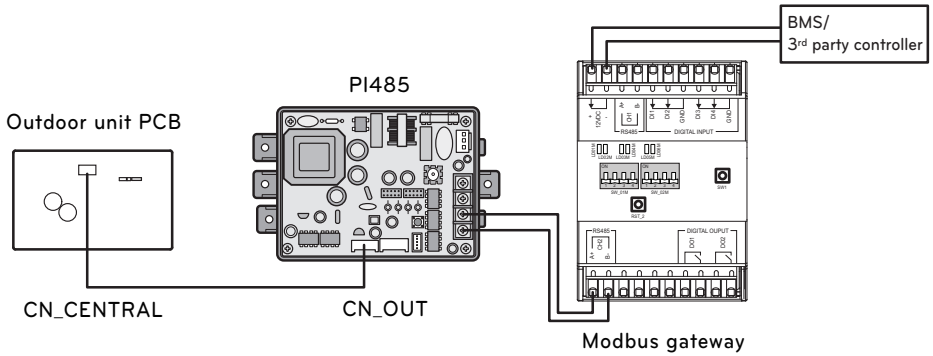

Dry Contact

Dry Contact is a solution for automatic control of HVAC system at the owner's best. In simple words, it's a switch which can be used to turn the unit On/Off after getting the signal from external sources.

How to install dry contact

[Parts of Dry contact]



Dry Contact body



Cable(for connecting with IDU)

Follow below procedures step 1 ~ step 6.

Step 1. Check if the power of the unit is turned off.

Step 2. Disassemble front panels and distinguish terminal block in Indoor PCB.

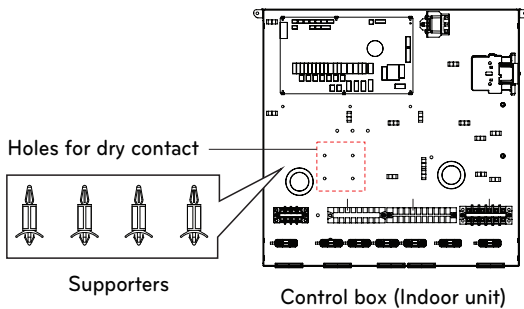

Step 3. Before installing the dry contact PCB inside control box, Remove the marking label on control box for using the holes.

Step 4. Secure the dry contact PCB using the provided supporters in control box.

Step 5. Connect cable to the unit PCB(CN_CC) fully.

Step 6. Then, Insert harness to the dry contact PCB(CN_INDOOR) firmly as shown below.

(For Split IWT)

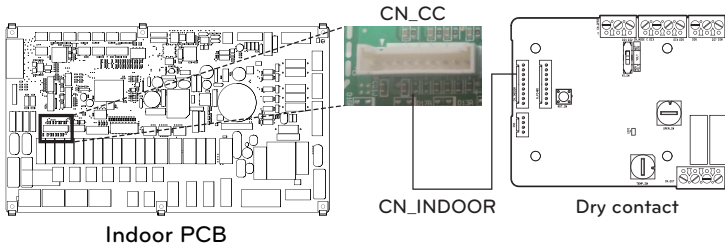

(For Hydrosplit IWT)

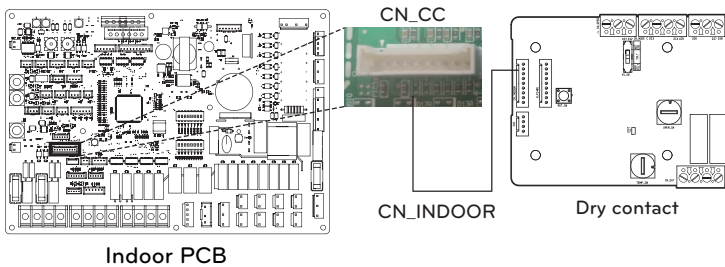
**NOTE**

- For more information about installing Dry Contact, Please refer installation manual provided with Dry Contact.
- For system set-up, please read chapter 9.

[Setting of Contact Signal Input - PDRYCB320]

- For input contact closure only(No power input)

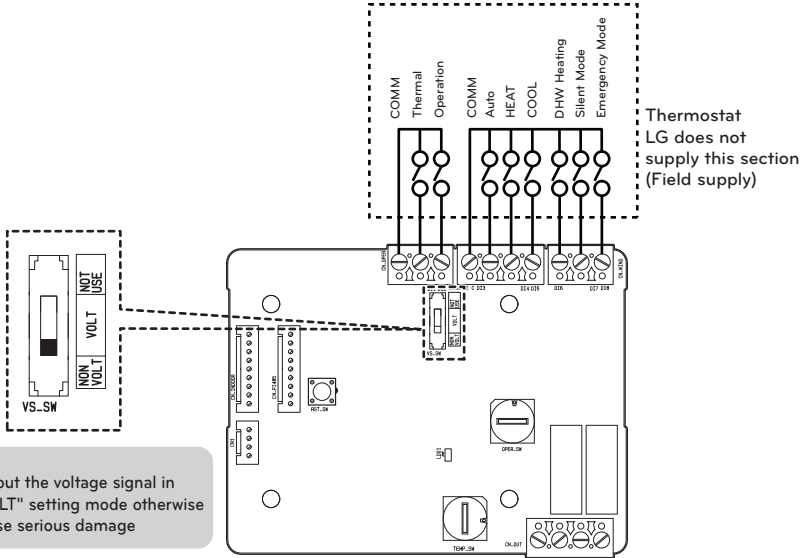

Notes

Do not input the voltage signal in "NON VOLT" setting mode otherwise it will cause serious damage

- For input contact voltage : DC 12 V, AC 24 V~

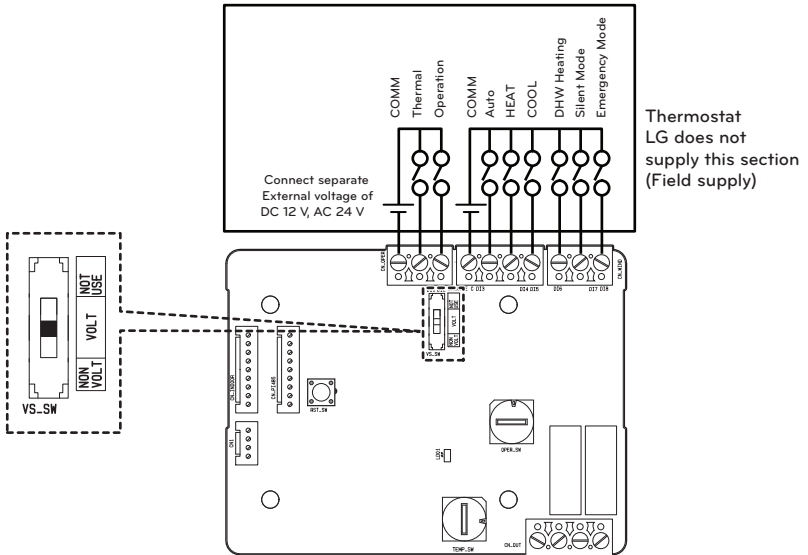

External Controller - Setting up programmable digital input operation

If you require to control depending on external digital input(ON/OFF), connect cable to indoor PCB(CN_EXT).

Follow below procedures step 1 ~ step 4.

Step 1. Check if the power of the unit is turned off.

Step 2. Disassemble front panels and distinguish control box(Indoor) of the unit

Step 3. Check of the harness(Blue) is insert fully to the indoor unit PCB (CN_EXT)

Step 4. Connect the external controller part to terminal block 4 using one of below installation examples.

(For Split IWT)

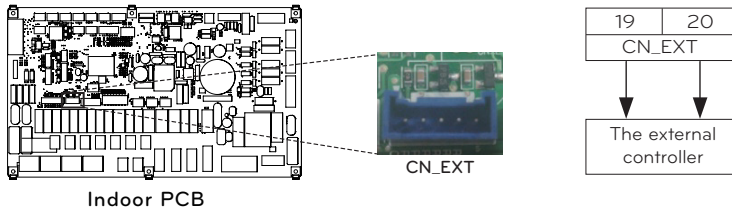

(For Hydrosplit IWT)

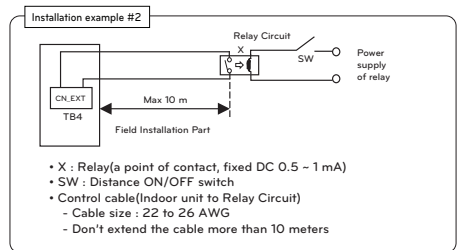
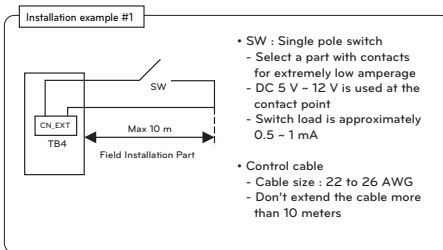
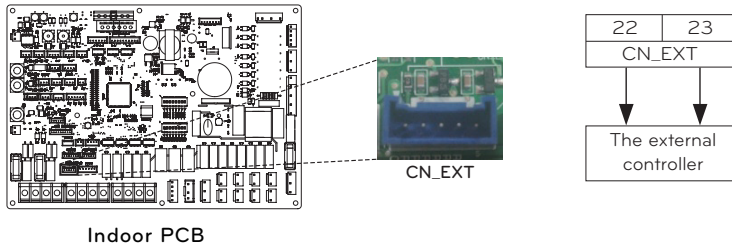

Determining the purpose of CN_EXT

Setting value: 0 ~ 3 step Indoor CN_EXT port setting

- 0: default (Not used)
- 1: Simple operation on / off
- 2: Simple dry contact operation
- 3: Simple emergency stop

Remote Temperature Sensor

Remote temperature sensor can be installed any place a user wants to detect the temperature.

- The function is not available for some products.

Installation condition

Role and constraint while installation of remote air temperature sensor is very similar to that of thermostat.

- Distance between the unit and the remote air temperature sensor should be less than 15 m due to length of the connection cable of remote air temperature sensor.
- For other constraints, please refer to previous page where constraints about thermostat is described.

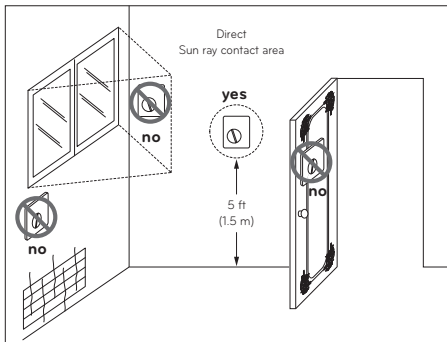

Thermostat

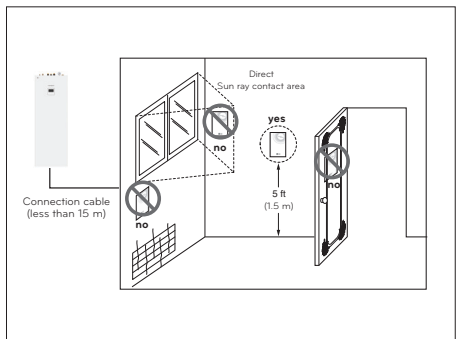

Remote Air Temperature Sensor

How to Install Remote Temperature Sensor

[Parts of Remote Temperature Sensor]



Remote sensor



Connection wire



Screw(to fix remote sensor)

Follow below procedures step 1 ~ step 6.

Step 1. Decide where the remote temperature sensor is installed. Then, Determine the location and height of the fixing screws in fig. 1 (Interval between the screws : 60 mm)

Step 2. Check if the power of the unit is turned off.

Step 3. Disassemble front panels and distinguish control box(Indoor) of the unit.

Step 4. Insert temperature sensor into PCB(CN_ROOM) and fix the sensor firmly in fig. 2.

Step 5. The Connection wire does not matter if you change the color of the wire because of nonpolar.

(For Split IWT)

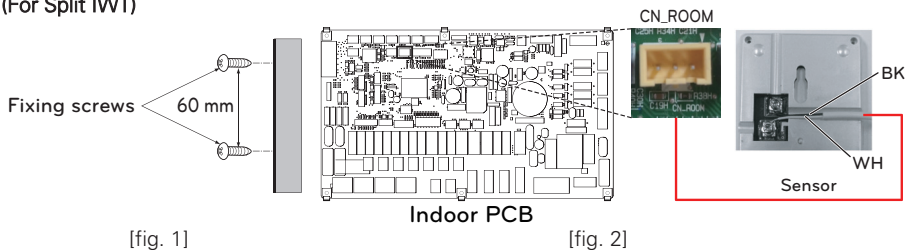

(For Hydrosplit IWT)

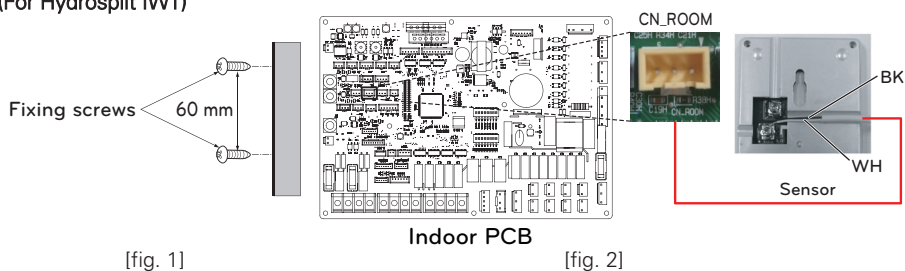

Step 6. Integrate the remote temperature sensor with the screws as the order of arrows.

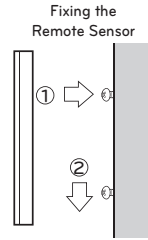

CAUTION

- Choose the place where the average temperature can be measured for the unit operates.
- Avoid direct sunlight.
- Choose the place where the cooling/heating devices do not affect the remote sensor.
- Choose the place where the outlet of the cooling fan do not affect the remote sensor.
- Choose the place where the remote sensor isn't affected when door is open.

NOTE

- For more information about installing Remote Temperature Sensor, Please refer installation manual provided with Remote Temperature Sensor.
- For system set-up, please read chapter 9.

External pump

External pump can be required when the room to take floor heating is too long or the pressure drop of heat emitter is too large to produce the required flow rate.

Also, the external pump shall be installed to assist water circulation when the buffer tank is installed.

How to wire external pump

Follow below procedures step 1 ~ step 3.

Step 1. Check if the power of the unit is turned off.

Step 2. Disassemble front panels and distinguish terminal block in Indoor PCB.

Step 3. Connect signal cable to terminal block fully.

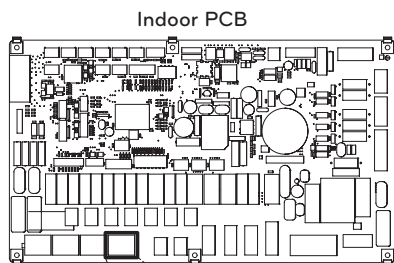

TB_EXT_PUMP



External pump
(Voltage free)

(For Split IWT)

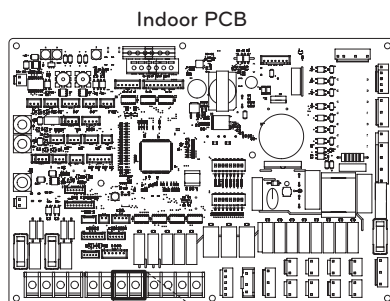

PUMP A2



External pump
(Voltage free)

(For Hydrosplit IWT)

Wi-fi Modem

Wi-fi modem enables remote system operation from smartphone. Available functions include selection of on/off, operation mode, DHW heating, temperature setup and weekly scheduling etc.

How to install Wi-fi Modem

[Parts of Wi-fi modem]

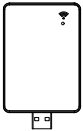

Wi-fi modem body

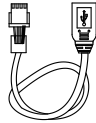

USB Cable

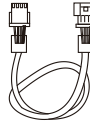

Extension Cable

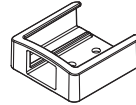

Holder

Follow below procedures step 1 ~ step 6.

Step 1. Check if the power of the unit is turned off.

Step 2. Disassemble front panels and distinguish control box(Indoor) of the unit.

Step 3. Connect the USB cable to the indoor unit PCB (CN_WF ; Blue) until it clicks into place.

Step 4. Connect the Wi-Fi modem to the USB cable fully.

Step 5. Refer to the image below to install the Wi-Fi modem in the marked position.

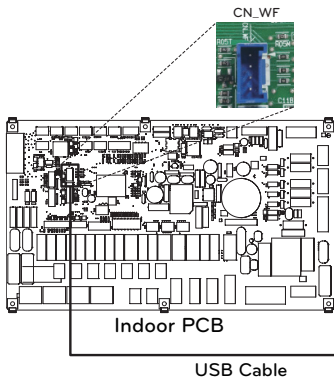

(For Split IWT)

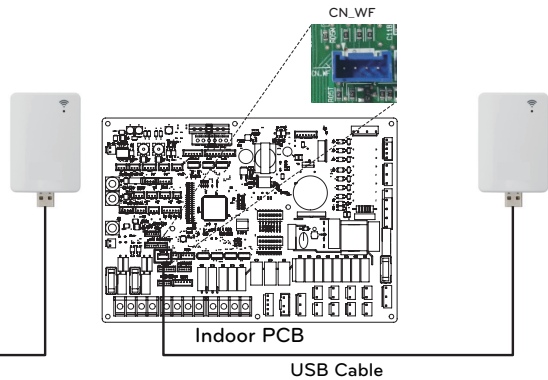

(For Hydrosplit IWT)

Step 6. Secure the holder of Wi-fi modem on top cover of the product.

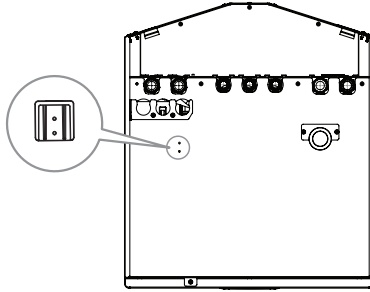

NOTE

- Please install the Wi-fi modem outside the product for smooth operation.
- Extension cable[PWYREW000] can be used if the length of the connecting cable is insufficient.

Smart Grid (For Split IWT)

This product provides smart grid function for users. It enables to stop internal operation(Heating / DHW) and control target temperature depending on input signal from power provider.

How to wire smart grid signal

Follow below procedures step 1 ~ step 3.

Step 1. Check if the power of the unit is turned off.

Step 2. Disassemble front panels and distinguish terminal block in Indoor PCB.

Step 3. Connect signal cable to terminal block in PCB (TB_SG2, TB_SG1) fully as shown below.

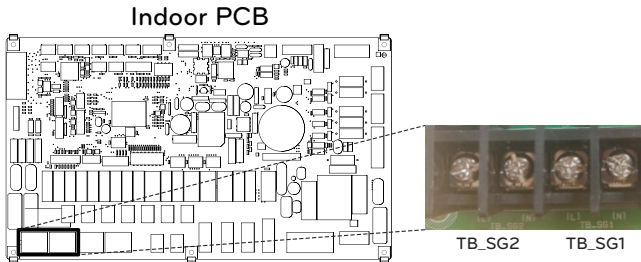

Heating and DHW Operation depend on input signal(SG1 / SG2)

Status display	Input Signal		Command	Cost (Electric)	Operation	
	SG1	SG2			Heating	Domestic How Water
SGN	Open	Open	Normal Operation	Normal Price	Maintain operation status	Maintain operation status
SG1	Close	Open	Operation Off (Utility lock)	High Price	Forced internal operation off	Forced internal operation off
SG2	Open	Close	Operation On Recommend	Low Price	Target temperature change automatically depend on SG Mode value in installer setting - Step 0 : maintain target temperature - Step 1 : increase 2 °C from target temperature - Step 2 : increase 5 °C from target temperature	Target temperature change automatically depend on SG Mode value in install setting - Step 0 : increase 5 °C from target temperature - Step 1 : increase 5 °C from target temperature - Step 2 : increase 7 °C from target temperature
SG3	Close	Close	Operation On Command	Very Low Price	Maintain operation status	Target temperature change automatically to 80 °C

Energy State (For Hydrosplit IWT)

This product provides energy states that enable customers to use as much as possible of their own renewable energy. It can shift setpoints depending on input signal from Energy Storage System (ESS) or from any other third-party device using Modbus RTU or Digital 230V inputs.

Available Energy States

There are 8 energy states available. 4 fixed and 4 customizable - each with the possibility to enhance Self-consumption of renewable energy.

Energy state	Command	Battery State of charge	Operation (standard setting)					
			Heating		Cooling		Domestic Hot Water	
			Setting	Range	Setting	Range	Setting	Range
1	Operation Off (Utility lock)	Low	Forced internal operation off	Fixed	Forced internal operation off	Fixed	Forced internal operation off	Fixed
2	Normal Operation	Normal	Maintain operation status	Fixed	Maintain operation status	Fixed	Maintain operation status	Fixed
3	Operation On Recommend	High	Increase 2 °C from target temperature	Fixed	Maintain operation Status	Fixed	Increase 5 °C from target temperature	Fixed
4	Operation On Recommend	Very High	Maintain operation status	Fixed	Maintain operation status	Fixed	DHW Target 80 °C	Fixed
5	Operation On Command	Very High	Increase from target temperature	0/+30 (Default : +5)	Decrease from target temperature	0/-30 (Default : -5)	Increase from target temperature	0/+50 (Default : +30)
6	Operation On Recommend	High	Increase from target temperature	0/+30 (Default : +2)	Decrease from target temperature	0/-30 (Default : -2)	Increase from target temperature	0/+50 (Default : +10)
7	Operation Save	Low	Decrease from target temperature	0/-30 (Default : -2)	Increase from target temperature	0/+30 (Default : +2)	Decrease from Target Temperature	0/-50 (Default : 0)
8	Operation Super Save	Very Low	Decrease from target temperature	0/-30 (Default : -5)	Increase from target temperature	0/+30 (Default : +5)	Decrease from Target Temperature	0/-50 (Default : 0)

Digital Input for energy saving (ESS, Smart Grid) (For Hydrosplit IWT)

This product provides two digital inputs (ES1/ES2) that can be used to switch between energy states when not using Modbus RTU (CN_MODBUS).

Available Energy States

There are 8 energy states available in total. Four different states can be triggered using the 230V-inputs – by default Energy states 1-4.

With the digital input assignment in the menu 'Energy state/Digital input assignment' of the control panel, different Energy states can be selected for Signals 0:1 and 1:1.

0:0 is always linked with ES2 (Normal operation) and 1:0 is always linked with ES1 (Operation off/Utility lock).

How to set Digital input signal

Follow below procedures step 1 ~ step 3.

Step 1. Check if the power of the unit is turned off.

Step 2. Disassemble front panels and distinguish terminal block in Indoor PCB.

Step 3. Connect signal cable to terminal block in PCB (ES2, ES1) fully as shown below.

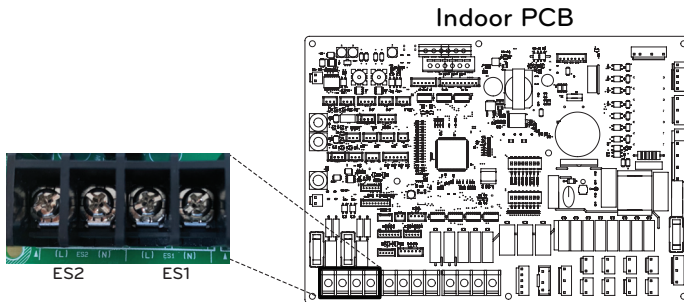

Energy state depending on input signal (ES1/ES2)

Input Signal		Output state	
ES1	ES2	Default	Range
0	0	ES2	fixed
1	0	ES1	
0	1	ES3	ES3-ES8
1	1	ES4	

2Way Valve

2way valve is required to control water flow while cooling operation. Role of 2way valve is to cut off water flow into under floor loop in cooling mode when fan coil unit is equipped for cooling operation.

General Information

THERMAV. supports following 2way valve.

Type	Power	Operating Mode	Supported
NO 2-wire (1)	230 V AC	Energize : Valve closing	Yes
		De-energize : Valve opening	
NC 2-wire (2)	230 V AC	Energize : Valve opening	Yes
		De-energize : Valve closing	

(1) : Normal Open type. When electric power is NOT supplied, the valve is open. (When electric power is supplied, the valve is closed.)

(2) : Normal Closed type. When electric power is NOT supplied, the valve is closed. (When electric power is supplied, the valve is open.)

How to Wire 2Way Valve

Follow below procedures Step 1 ~ Step 2.

Step 1. Uncover front cover of the unit.

Step 2. Find terminal block and connect wire as below.

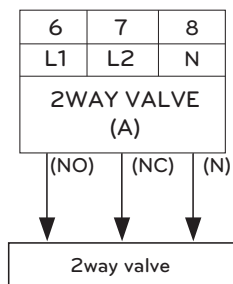

CAUTION

Dew Condensation

- Wrong wiring can yield dew condensation on the floor. If radiator is connected at the under floor water loop, dew condensation can be occurred on the surface of the radiator.

WARNING

Wiring

- Normal Open type should be connected to wire (NO) and wire (N) for valve opening in cooling mode.
- Normal closed type should be connected to wire (NC) and wire (N) for valve closing in cooling mode.

(NO) : Live signal (for Normal Open type) from PCB to 2way valve.

(NC) : Live signal (for Normal Closed type) from PCB to 2way valve.

(N) : Neutral signal from PCB to 2way valve.

Final Check

- Flow direction :
 - Water should not flow into under floor loop in cooling mode.
 - To verify the flow direction, check temperature at the water inlet of the under floor loop.
 - If correctly wired, this temperatures should not be reached below 16 °C in cooling mode.

Final check

No.	Check point	Description
1	Connection of Water Inlet/Outlet	<ul style="list-style-type: none"> - Check if the shut-off valves should be assembled with Water inlet and outlet pipe of the unit - Check the location of the water inlet/outlet water pipe
2	Hydraulic pressure	<ul style="list-style-type: none"> - Check the pressure of supplying water by using pressure gauge inside the unit - Pressure of Supplying water should be Under 3.0 bar approximately - Pressure of Supplying tank water should be Under 10.0 bar approximately
3	Water pump capacity	<ul style="list-style-type: none"> - To secure enough water flow rate, do not set water pump capacity as Minimum. - It can lead unexpected flow rate error CH14. (Refer to Chapter 4 'Water Piping and Water Circuit Connection')
4	Transmission line and power source wiring	<ul style="list-style-type: none"> - Check if Transmission line and power source wiring are separated from each other. - If it is not, electronic noise may occur from the power source.
5	The power cord specifications	<ul style="list-style-type: none"> - Check the power cord specifications (Refer to Chapter 4 'Connecting Cables')
7	2Way Valve	<ul style="list-style-type: none"> - Water should not flow into under floor loop in cooling mode. - To verify the flow direction, check temperature at the water inlet of the under floor loop. - If correctly wired, this temperatures should not be reached below 16 °C in cooling mode.
8	Air Vent	<ul style="list-style-type: none"> - Air-vent must be located highest level of Water pipe system - It should be installed at the point which is easy to service. - It takes some times to remove air in the water system if air purge is not performed sufficiently it may occur CH14 error. (refer to Chapter 4 'Water Charging')

CONFIGURATION

As **THERMAX** is designed to satisfy various installation environment, it is important to set up system correctly. If not configured correctly, improper operation or degrade of performance can be expected.

DIP Switch Setting (For Split IWT)

CAUTION

Turn off electric power supply before setting DIP switch

- Whenever adjusting DIP switch, turn off electric power supply to avoid electric shock.





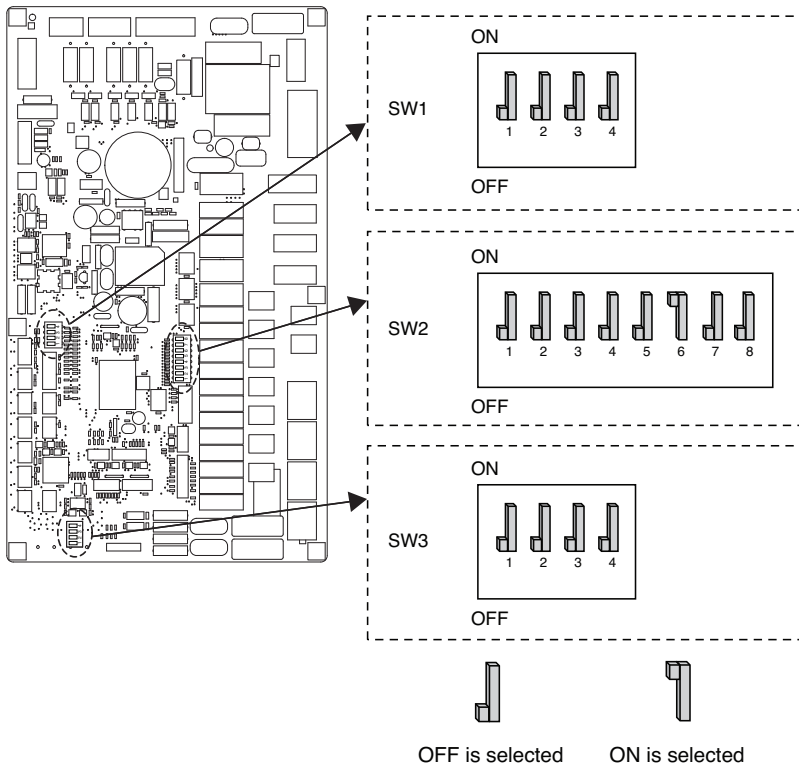























General Information

Indoor PCB









DIP Switch Information

Option Switch 2







Description	Setting		Default
Group control	1 	As Master	1 
	1 	As Slave	
Accessory installation information	2  3 	DHW integrated indoor unit + Outdoor unit is installed	2  3 
	2  3 		
	2  3 		
	2  3 	Reserved	
Cycle	4 	Heating Only	4 
	4 	Heating & Cooling	
Selecting electric heater capacity	6  7 	Electric heater is not used	6  7 
	6  7 	Electric heater is used	
	6  7 	Reserved	
	6  7 		
Thermostat installation information	8 	Thermostat is NOT installed	8 
	8 	Thermostat is installed	

* DIP switch no.5 have no function.

Option Switch 1

Description	Setting		Default
MODBUS Communication Type	1 	As Master (LG Extension Module)	1 
	1 	As Slave (3 rd Party Controller)	
MODBUS Function	2 	REGINE	2 
	2 	Unified Open Protocol	

Option Switch 3

Description	Setting		Default
Remote Room air sensor (Accessory)	1 	Remote sensor is not installed	1 
	1 	Remote sensor is installed	
Antifreeze agent	2 	Antifreeze agent is not used	2 
	2 	Antifreeze agent is used *	

* Only the switch in the table has a function. Others have no function.





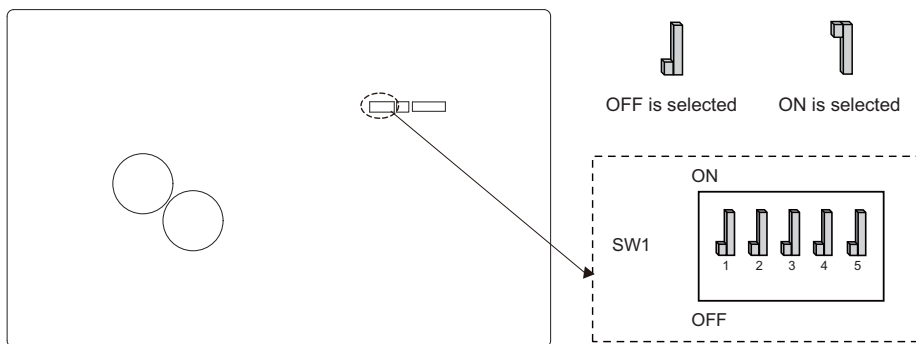

* Possibility to allow colder water temperature by setting. Bridge at CN_FLOW2 must be disconnected to enable setting

Outdoor PCB (5, 7, 9 kW)

U36A Chassis



DIP Switch Information

Description	Setting		Default
Low Noise Mode	2 	Always Mode - Maintain Low noise mode for target temperature	2 
	2 	Partial Mode - Escape low noise mode for target temperature	
Peak Control	3 	Max Mode	3 
	3 	Peak Control : To limit maximum current (Power saving)	

* Only DIP-switch no. 2 and no.3 has a function. Others have no function.

* When setting the on/off partial mode, Mode can be exited to secure capacity after operating for a certain time.

NOTE

* Input current value can be limited by DIP Switch operation.

Capacity	Mode	Peak Control Mode Running Current(A)
1Ø 5,7,9 kW	Cooling	13 / 14 / 15
	Heating	13 / 14 / 15

DIP Switch Setting (For Hydrosplit IWT)

CAUTION

Turn off electric power supply before setting DIP switch

- Whenever adjusting DIP switch, turn off electric power supply to avoid electric shock.





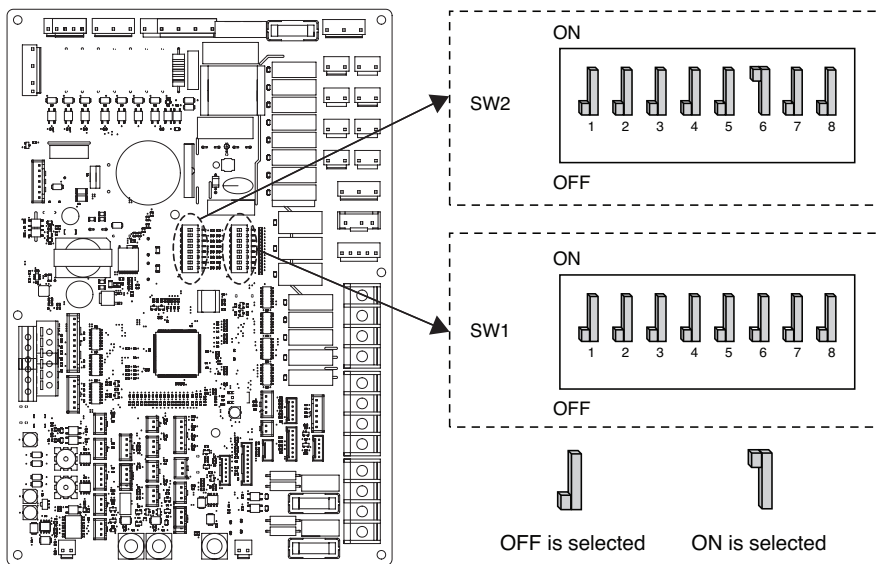

























General Information

Indoor PCB











DIP Switch Information

Option Switch 2

Description	Setting		Default
Group control	1 	As Master	1 
	1 	As Slave	
Accessory installation information	2  3 	DHW integrated indoor unit + Outdoor unit is installed	2  3 
	2  3 		
	2  3 		
	2  3 	Reserved	
Cycle	4 	Heating Only	4 
	4 	Heating & Cooling	
Room Air Sensor	5 	Room Air Sensor is not installed	5 
	5 	Room Air Sensor is installed	
Selecting electric heater capacity	6  7 	Electric heater is not used	6  7 
	6  7 	Electric heater is used	
	6  7 	Reserved	
	6  7 		
Thermostat installation information	8 	Thermostat is NOT installed	8 
	8 	Thermostat is installed	

Option Switch 1

Description	Setting		Default
MODBUS	1 	As Master (LG Extension Module)	1 
	1 	As Slave (3 rd Party Controller)	
MODBUS Function	2 	REGINE	2 
	2 	Unified Open Protocol	
ANTIFREEZE	8 	Antifreeze mode not use	8 
	8 	Antifreeze mode *	



※ Only the switch in the table has a function. Others have no function.

* Possibility to allow colder water temperature by setting.
Bridge at CN_ANTI_SW must be dis-connected to enable setting.

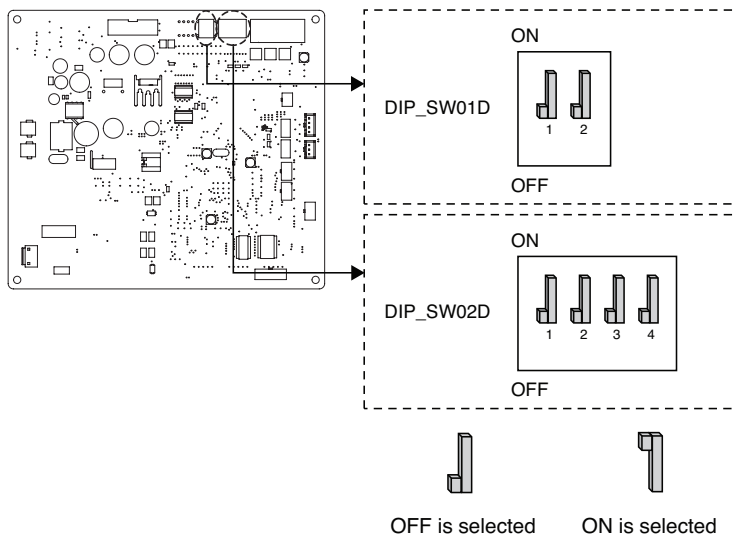







Outdoor PCB (12, 14, 16 kW)









Option Switch 1

Description	Setting		Default
Low Noise Mode	2 	Always Mode - Maintain Low noise mode for target temperature	2 
	2 	Partial Mode - Escape low noise mode for target temperature	

Option Switch 2

Description	Setting		Default
Peak Control	1  2 	Max Mode	1  2 
	1  2 	Peak Control Step 1 : To limit maximum current (Power saving)	
	1  2 	Peak Control Step 2 : To limit maximum current (Power saving)	

Option Switch 1 & 2

Description	Setting			Default
Defrost Mode	Option Switch 1  2	Option Switch 2  3	Normal Defrost Mode - The same mode as the existing defrost logic	Option Switch 1  2
	Option Switch 1  2	Option Switch 2  3	Rapid Defrost Mode - Rapid defrost mode in adverse defrosting conditions	Option Switch 2  3

* Only the switch in the table has a function. Others have no function.

* When setting the on/off partial mode, Mode can be exited to secure capacity after operating for a certain time.

NOTE

* Input current value can be limited by DIP Switch operation.

Capacity	Mode	Peak Control Mode Running Current(A)	
		Step 1	Step 2
1Ø 12,14,16 kW	Cooling	23 / 24 / 25	20 / 21 / 22
	Heating	23 / 24 / 25	20 / 21 / 22
3Ø 12,14,16 kW	Cooling	8 / 9 / 10	6 / 7 / 8
	Heating	8 / 9 / 10	6 / 7 / 8

NOTE**Emergency Operation****• Definition of terms**

- Trouble : a problem which can stop system operation, and can be resumed temporarily under limited operation without certificated professional's assist.
- Error : problem which can stop system operation, and can be resumed ONLY after certificated professional's check.
- Emergency mode : temporary heating operation while system met Trouble.

• Objective of introducing 'Trouble'

- Not like air conditioning product, Air-to-Water heat pump is generally operation in whole winter season without any system stopping.
- If system found some problem, which is not critical to system operating for yielding heating energy, the system can temporarily continue in emergency mode operation with end user's decision.

• Classified Trouble

- Trouble is classified two levels according to the seriousness of the problem : Slight Trouble and Heavy trouble
- Slight Trouble : a problem is found inside the unit. In most case, this trouble is concerned with sensor problems. The outdoor unit is operating under emergency mode operation condition which is configured by DIP switch No. 4 of the unit PCB.
- Heavy trouble : a problem is found inside the outdoor unit. As the outdoor unit has problem, the emergency mode operation is performed by electric heater located in the unit.
- Option Trouble : a problem is found for option operation such as water tank heating. In this trouble, the troubled option is assumed as if it is not installed at the system.

• When the AWHP has any trouble,

(1) If there is not a function to judge possibility of operation :

Once an error occurs mainly in indoor unit, AWHP stops. On the other hand, remote controller allows the product to activate On/ Off operation. (On : emergency operation)

- Slight / Heavy trouble : Heating Operable only
- Critical trouble : Full stop
- Treatment priority : Critical>Heavy>Slight

(2) If there is a function to judge possibility of operation :

Depending on the status of slight / heavy / critical trouble, pop-up phrase is guided separately on display.

- Slight trouble : Heating/Cooling Operable
- Heavy trouble : Heating Operable only
- Critical trouble : Service center request

AWHP operates when user pressed OK button on pop-up window.

NOTE**• Duplicated trouble : Option trouble with slight or heavy trouble**

- If option trouble is occurred with slight (or heavy) trouble at the same time, the system puts higher priority to slight (or heavy) trouble and operates as if slight (or heavy) trouble is occurred.
- Therefore, sometimes DHW heating can be impossible in emergency operation mode. When DHW is not warming up while emergency operation, please check if DHW sensor and related wiring are all Ok.

• Emergency operation is not automatically restarted after main electricity power is reset.

- In normal condition, the product operating information is restored and automatically restarted after main electricity power is reset.
- But in emergency operation, automatic re-start is prohibited to protect the product.
- Therefore, user must restart the product after power reset when emergency operation has been running.

SERVICE SETTING

How to enter service setting

To enter the menu displayed at the bottom, you need to enter the service setting menu as follows.

- In the menu screen, press [←,→(left/right)] button to select the setting category, and press [OK] button to move to the setting list.
- In the setting list, select the service setting category, and press [OK] button to move to the service setting list.

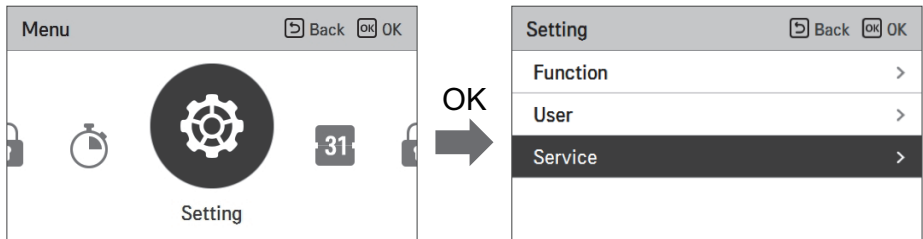

Service setting

- You can set the product service functions.
- Some functions may not be displayed/operated in some product types.

Menu	Description
Service contact	Check and input the service center phone number that you can call when there is service issue.
Model information	View product and capacity information
RMC Version Information	Check the remote controller model name and software version.
Open Source License	View the remote controller's open source license.

Service contact

Check and input the service center phone number that you can call when there is service issue.

- In the service setting list, select the service contact point and press [OK] button to move to the detail screen.
- While “edit” button is selected, press [OK] button to move to the edit screen, change it, and press [OK] button to change the service contact point.

Service	Back	OK
Service Contact		>
Model Information		>
RMC Version Information		>
Open Source License		>



Service Contact	Back	OK
Telephone +1544-7777		
Edit		



Service Contact	Back	OK
Telephone		
+	1	5 4 4 - 7 7
7 7		

Model information

Check product and capacity information to which the remote controller is connected.

- In the service setting list, select model information category, and press [OK] button to move to the detail screen.
- The unit capacity
 - $1 \text{ kWh} = 1 \text{ kBtu} * 0.29307$
 - kWh is the result calculated based on Btu, There may be a small difference between calculated and actual capacity.
 - Ex) If the unit capacity is 18 kBtu, it is displayed as 5 kWh.

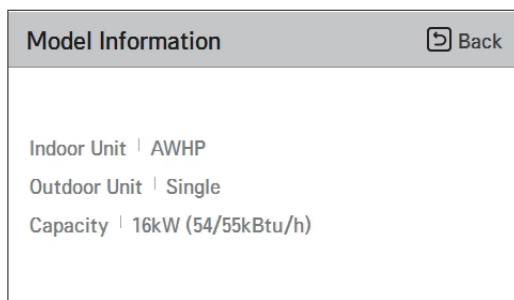
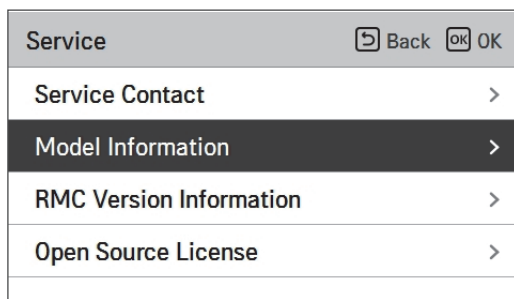

RMC version information

View the remote controller software version.

- In the service setting list, select the RMC version information and press [OK] button to move to the detail screen

Service	Back	OK
Service Contact	>	
Model Information	>	
RMC Version Information	>	
Open Source License	>	



RMC Version Information	Back
SW Version 3.03.1a	

Open source license

View the remote controller's open source license.

- In the service setting list, select the open source license category, and press [OK] button to move to the detail screen.

Service	Back	OK
Service Contact	>	
Model Information	>	
RMC Version Information	>	
Open Source License	>	



Open Source License		Back
LGE Open Source Software Notice		
Product Type	HVAC WIRED REMOTE CONTR	
Model Number/Range	RS3 Wired Remote Controller	1/401
Those products identified by the Product Type and Model Range above from LG Electronics, Inc. ("LGE") contain the open source software detailed below. Please refer to the		

INSTALLER SETTING

How to enter installer setting

CAUTION

The installer setting mode is the mode to set the remote controller's detail function. If the installer setting mode is incorrectly set, it may cause product failure, user's injury, or property damage. It must be set by the installation specialist with the installation license, and if it is installed or changed without installation license, all problems caused will be the responsibility of the installer, and may void the LG warranty.

- In the menu screen, press [←,→(left/right)] button to select the setting category, and press [^ (up)] button for 3 seconds to enter the password input screen for the installer setting.
- Input the password and press [OK] button to move to the installer setting list.

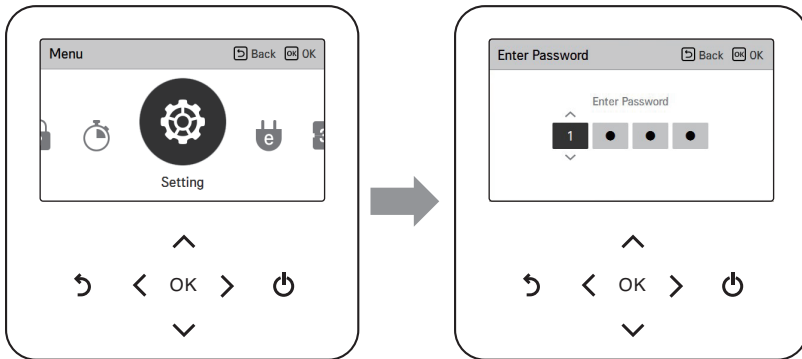

* Installer setting password

Main screen → menu → setting → service → RMC version information → SW Version

Example) SW version : 1.00.1 a

In the above case, the password is 1001.

NOTE

Some categories of the installer setting menu may not be available depending on the product function or the menu name may be different.

Installer setting (For Split IWT)

- You can set the product user functions.
- Some functions may not be displayed/operated in some product types.

Configuration

Function	Description
Select Temperature Sensor	Selection for setting temperature as air temperature or water temperature or air+water temperature.
Use Heating Tank Heater	Determine the delay time of the electric heater for the water tank.
Mixing Circuit	This function is to use mixing circuit function. Set enable/disable mixing circuit function and valve closing time and hysteresis.
Use External Pump	Set up to control an external water pump.
RMC master/slave	This function is to set master / slave to use two remote controllers in one indoor unit.
LG Therma V Configuration	This function can be set to save the environment settings of the product for use in LG Therma V Configurator through Micro SD card. (LG heating configurator)

General

Function	Description
Forced operation	Main water pump off After 20 consecutive hours, disable / enable the logic that drives the water pump by itself.
Pump Capacity	Function to change Main water pump Capacity.
Pump Prerun/Overrun	Set to reach the optimum flow rate by circulating the heating water with the water pump before heat exchange. After the operation stop, additional water pump is activated to circulate the heating water.
Password Reset	It is the function to reset (0000) the password when you forgot the password set in the remote controller.

Room Heating

Function	Description
Heating temp. setting	At the water control in heating mode, the control reference water temperature position setting.
Air heating set temp.	Adjusting range of 'Setting Air Temperature' in heating mode
Water heating set temp.	Adjusting range of 'Setting Leaving water Temperature' in heating mode.
TH on/off Variable, heating air	Heating air temperature TH On / Off Type setting
TH on/off Variable, heating water	Heating Water Outlet Temperature TH On / Off Type
Pump setting in heating	Set water pump on/off interval option during thermo off condition in heating mode
Heater on temperature	Setting outdoor air temperature where electric heater starts operation.
Screed drying	This function controls floor heating to a specific temperature for a certain period of time to cure floor cement.

Room Cooling

Function	Description
Cooling temp. setting	At the water control in cooling mode, the control reference water temperature position setting.
Air cooling set temp.	Adjusting range of 'Setting Air Temperature' in cooling mode.
Water cooling set temp.	Adjusting range of 'Setting Leaving Water Temperature' in cooling mode.
Water supply off temp. during cooling	Determine the leaving water temperature which blocks the flow into underfloor coil in cooling mode.
TH on/off Variable, cooling air	Cooling air temperature TH On / Off Type setting
TH on/off Variable, cooling water	Cooling Water Outlet Temperature TH On / Off Type.
Pump setting in cooling	Set water pump on/off interval option during thermo off condition in cooling mode.

Auto Mode

Function	Description
Seasonal auto temp	Set the operating temperature in Seasonal Auto mode.

Domestic Hot Water

Function	Description
DHW set temp.	Setting DHW set temperature.
Tank disinfection setting 1	Setting start/maintain time for disinfection.
Tank disinfection setting 2	Setting disinfection temperature.
Tank setting1	Setting minimum and maximum temperature using heat pump cycle for DHW heating.
Tank setting2	Setting temperature hysteresis.
DHW time setting	Determine follow time duration : operation time of domestic hot water tank heating, stop time of domestic hot water tank heating, and delay time of DHW tank heater operating.

Service

Function	Description
Pump test run	Main water pump test run.
Frost Protection Temp.	the function is to apply an offset to the freezing temperature of the freeze protection logic when using antifreeze mode.

Connectivity

Function	Description
Dry Contact Mode	Dry contact function is the function that can be used only when the dry contact devices is separately purchased and installed.
Central Control Address	Selection for setting temperature as air temperature or leaving water temperature or air+leaving water temperature.
CN_CC	It is the function to set whether to install (use) Dry Contact. (It is not a function for Dry Contact installation, but it is a function to set the usage of the unit's CN_CC port.)
Smart Grid(SG)	Select whether to use or not use the SG Mode function of the product, set the operation option value in SG1 step.
Modbus Address	It is function to set the address of the Modbus device that is externally linked to the product. Modbus address setting function is available from indoor unit.
CN_EXT	Function to set external input and output control according to DI / DO set by customer using dry contact port of indoor unit. Determine the use of the contact port (CN_EXT) mounted on the indoor unit PCB.
3 rd Party Boiler	Configuration to control 3 rd party boiler.
Meter Interface	When installing the meter interface to measure energy / calorie in the product, set unit spec for each port.

Information

Function	Description
Pump operation time	Function to check the main water pump operation time.
IDU operation time	Function to check the IDU operation time.
Current Flow Rate	Function to check the current flow rate.
Data logging	Display error history of connected unit.

Installer setting (For Hydrosplit IWT)

- You can set the product user functions.
- Some functions may not be displayed/operated in some product types.

Configuration

Function	Description
Select Temperature Sensor	Selection for setting temperature as air temperature or water temperature or air+water temperature.
Use Heating Tank Heater	Determine the delay time of the electric heater for the water tank.
Mixing Circuit	This function is to use mixing circuit function. Set enable/disable mixing circuit function and valve closing time and hysteresis.
Use External Pump	Set up to control an external water pump.
RMC master/slave	This function is to set master / slave to use two remote controllers in one indoor unit.
LG Therma V Configuration	This function can be set to save the environment settings of the product for use in LG Therma V Configurator through Micro SD card. (LG heating configurator)

General

Function	Description
Forced operation	Main water pump off After 20 consecutive hours, disable / enable the logic that drives the water pump by itself.
Pump Prerun/Overrun	Set to reach the optimum flow rate by circulating the heating water with the water pump before heat exchange. After the operation stop, additional water pump is activated to circulate the heating water.
Water Flow Control	Set water pump to control the water flow.
Password Reset	It is the function to reset (0000) the password when you forgot the password set in the remote controller.

Room Heating

Function	Description
Heating temp. setting	At the water control in heating mode, the control reference water temperature position setting.
Air heating set temp.	Adjusting range of 'Setting Air Temperature' in heating mode
Water heating set temp.	Adjusting range of 'Setting Leaving water Temperature' in heating mode.
Hysteresis Heating Water	Heating Water Outlet Temperature Hysteresis range setting
Hysteresis Room Air (Heating)	Heating air temperature Hysteresis range setting
Pump setting in heating	Set water pump on/off interval option during thermo off condition in heating mode
Heater on temperature	Setting outdoor air temperature where electric heater starts operation.
Screed drying	This function controls floor heating to a specific temperature for a certain period of time to cure floor cement.

Room Cooling

Function	Description
Cooling temp. setting	At the water control in cooling mode, the control reference water temperature position setting.
Air cooling set temp.	Adjusting range of 'Setting Air Temperature' in cooling mode.
Water cooling set temp.	Adjusting range of 'Setting Leaving Water Temperature' in cooling mode.
Water supply off temp. during cooling	Determine the leaving water temperature which blocks the flow into underfloor coil in cooling mode.
Hysteresis Cooling Water	Cooling Water Outlet Temperature Hysteresis range setting
Hysteresis Room Air (Cooling)	Cooling air temperature Hysteresis range setting
Pump setting in cooling	Set water pump on/off interval option during thermo off condition in cooling mode.

Auto Mode

Function	Description
Seasonal auto temp	Set the operating temperature in Seasonal Auto mode.

Domestic Hot Water

Function	Description
DHW set temp.	Setting DHW set temperature.
Tank disinfection setting 1	Setting start/maintain time for disinfection.
Tank disinfection setting 2	Setting disinfection temperature.
Tank setting1	Setting minimum and maximum temperature using heat pump cycle for DHW heating.
Tank setting2	Setting temperature hysteresis.
DHW time setting	Determine follow time duration : operation time of domestic hot water tank heating, stop time of domestic hot water tank heating, and delay time of DHW tank heater operating.

Service

Function	Description
Pump test run	Main water pump test run.
Frost Protection Temp.	the function is to apply an offset to the freezing temperature of the freeze protection logic when using antifreeze mode.

Connectivity

Function	Description
Dry Contact Mode	Dry contact function is the function that can be used only when the dry contact devices is separately purchased and installed.
Central Control Address	Selection for setting temperature as air temperature or leaving water temperature or air+leaving water temperature.
CN_CC	It is the function to set whether to install (use) Dry Contact. (It is not a function for Dry Contact installation, but it is a function to set the usage of the unit's CN_CC port.)
Modbus Address	It is function to set the address of the Modbus device that is externally linked to the product. Modbus address setting function is available from indoor unit.
CN_EXT	Function to set external input and output control according to DI / DO set by customer using dry contact port of indoor unit. Determine the use of the contact port (CN_EXT) mounted on the indoor unit PCB.
3 rd Party Boiler	Configuration to control 3 rd party boiler.
Meter Interface	When installing the meter interface to measure energy / calorie in the product, set unit spec for each port.
Energy state	Select whether to use or not use the SG Mode function of the product, set the operation option value in SG1 step.
Thermostat control type	Setting Thermostat control type

Information

Function	Description
Pump operation time	Function to check the main water pump operation time.
IDU operation time	Function to check the IDU operation time.
Current Flow Rate	Function to check the current flow rate.
Data logging	Display error history of connected unit.

Select Temperature Sensor

The product can be operated according to air temperature or water temperature. The selection for setting temperature as air temperature or water temperature is determined.

- In the installer setting list, Select Temperature Sensor category, and press [OK] button to move to the detail screen.

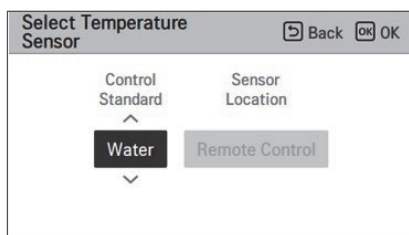
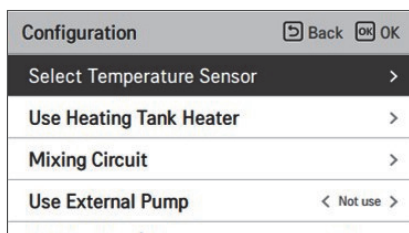
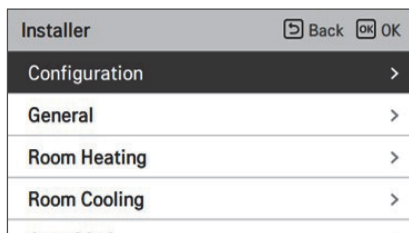

Control Standard	Sensor Location	Temperature target	Required accessories
Water (Default)	-	Inlet or Outlet water temp.	-
Air	Remote Control	Room air temp. only	Cover plate PDC-HK10 or (PREMTW101 + PZCWRC2)
	Indoor unit		Remote room sensor PQRSTA0 ¹⁾
Air+Water	Remote control	Room air temp. and (Inlet or Outlet) water temp.	Cover plate PDC-HK10 or (PREMTW101 + PZCWRC2)
	Indoor unit		Remote room sensor PQRSTA0 ¹⁾

NOTE

1) Sensor must be enabled by DIP switch first, before setting is available.

Use Heating Tank Heater

This is a function to determine the delay time of the electric heater for water tank.

- In the installer setting list, Select Configuration category, and press [OK] button to move to the detail screen.

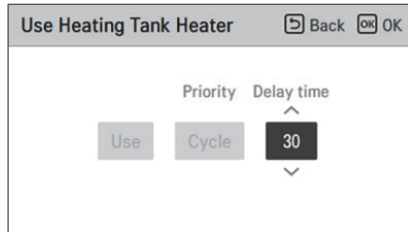
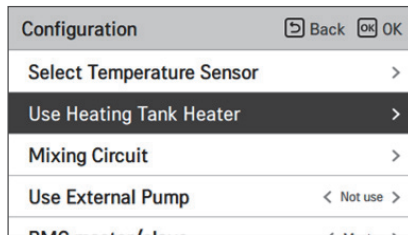
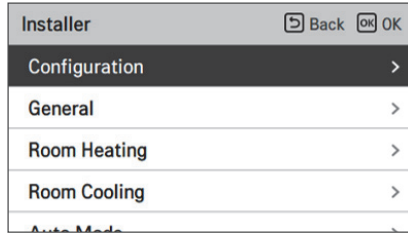

Function	Unit	Default	Value
Delay time	minute	30	10/20/30/40/50/60/90/120/1440

Mixing circuit (For Split IWT)

Function to set whether or not to use a installed mixing circuit function using mixing kit.

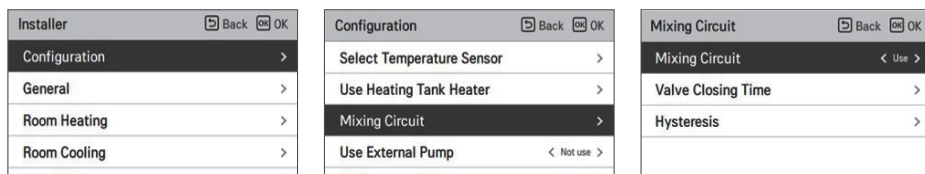

You can set valve closing time[s] and hysteresis temperature[°C] on screen by yourself.

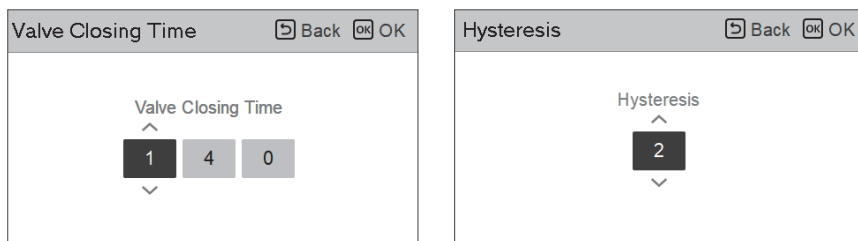

Activating this function, It allows 2 zones(Circuit1, Circuit2) temperature to be controlled, separately.

- In case of heating, the temperature of Circuit2 can not be set higher than Circuit1 temperature.
- In case of cooling, the temperature of Circuit2 can not be set lower than Circuit1 temperature.

Setting range

- Mixing circuit setting : Use / Not Use
- Value Closing Time : 60 ~ 999 s (Default: 240)
- Hysteresis (Thermal On / Off) : 1 ~ 5 °C (Default: 2)

Mixing Circuit (For Hydrosplit IWT)

Function to set whether or not to use an installed mixing circuit function using mixing kit.

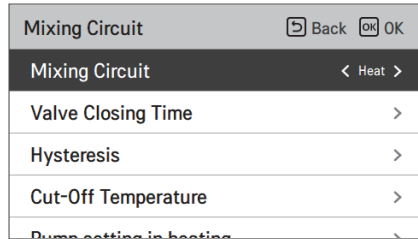
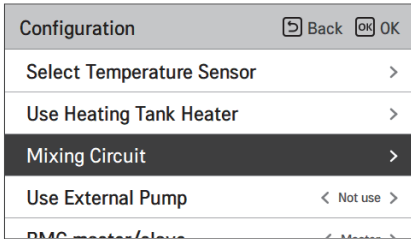

Value	Default
Not Use / Heat / Cool	Not Use

You can set valve closing time[s] and hysteresis temperature[°C] on screen by yourself. Setting the cut-off temperature protects the water from flowing over the cut-off temperature in the mixing circuit during heating operation.

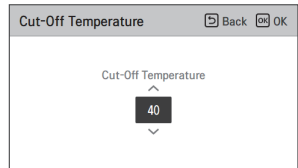
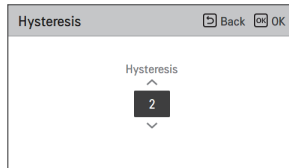
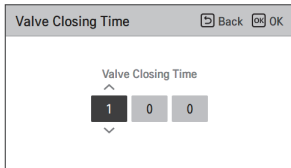

Value	Default	Range
Valve Closing Time	240 s	60 ~ 999 s
Hysteresis	2 °C	1 ~ 3 °C
Cut-Off Temperature	40 °C	20 ~ 65 °C

You can set the operation of the outdoor unit when only the mixing circuit is operating and the direct circuit is not operating.

Type1	Type2 (Default)
Outdoor Operation	Outdoor Not Operation

Mixing Circuit	Back	OK
Hysteresis		>
Cut-Off Temperature		>
Pump setting in heating		>
Pump setting in cooling		>
Comp. Operation	< Type2	>

Value	Default
Type 1 / Type 2	Type 2

CAUTION

Set Type 1 only at the installation site with a small load or no buffer tank.

When setting Type 1 in a site with a large load or a site with a buffer tank, overheating may occur in the direct circuit.

Installer setting function to set water mixing pump operation / delay time option in heating/cooling mode

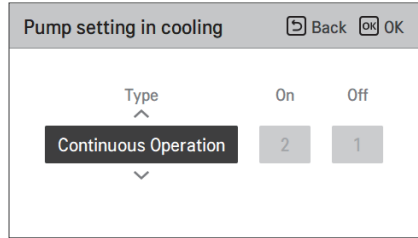
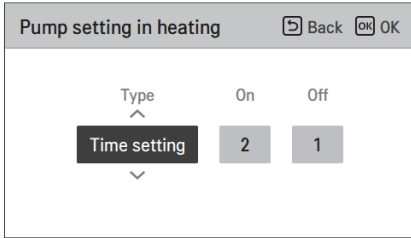

Value	Default	Range
Type	Time Setting	Time Setting / Continuous Operation
On	2 min	1 ~ 60 min
Off	1 min	1 ~ 60 min

* When Continuous Operation is selected, On, Off is disabled.

Activating this function, It allows 2 circuits (Circuit 1, Circuit 2) temperature to be controlled, separately.

NOTE

When using the Mixing Circuit function, the external pump setting must be changed to 'Circuit 1'.

Use External Pump (For Split IWT)

This function can be set to control the external water pump.

- In the installer setting list, select Use External Pump category, and press [OK] button to move to the detail screen.

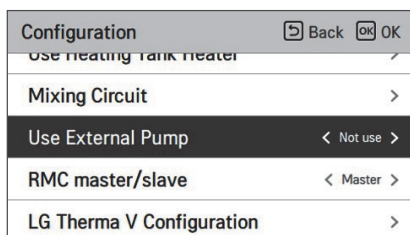
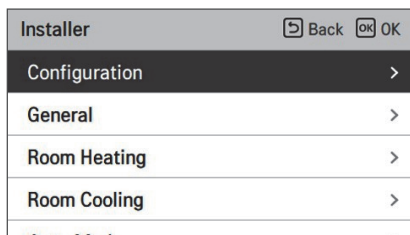

Value	
Not use (Default)	Use

Use External Pump (For Hydrosplit IWT)

This function can be set to control the external water pump.

- In the installer setting list, select Use External Pump category, and press [OK] button to move to the detail screen.
- Heating/Cooling
You can use this feature when you have installed a 3 Way valve to switch the water flow between the underfloor and the water tank. The external pump operates only in the direction of water flow in the underfloor.
- Circuit1
This function controls the external pump when operating the mixing circuit. The external pump should be controlled according to Th/on and Th/off in Circuit1(Direct circuit). Therefore, when using the mixing circuit, be sure to set the external pump to 'Circuit1'.

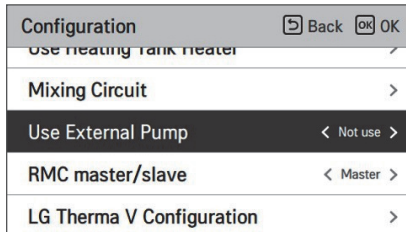
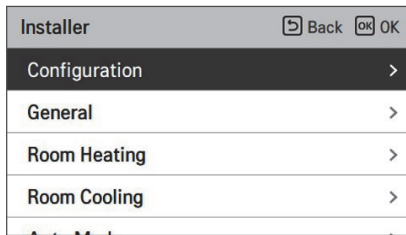

Value			
Not use (Default)	Use	Heat & Cool	Circuit1

RMC master/slave

This function can be select Master/Slave on remote controller to use 2 Remote Control environment

- In the Installer setting list, and select RMC master/slave setting category, and press [<, >] button to following setting values.

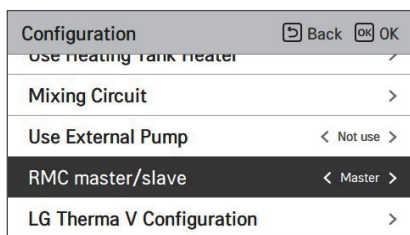
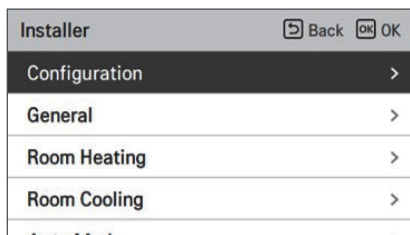

Value	
Master (Default)	Slave

LG Therma V Configuration

This function can be set to save the installation settings of the product for use in LG Therma V Configurator through SD Card (LG heating configurator).

- In the Installer setting list, and select LG Therma V Configuration setting category, and press [OK] button to move to the detail screen.

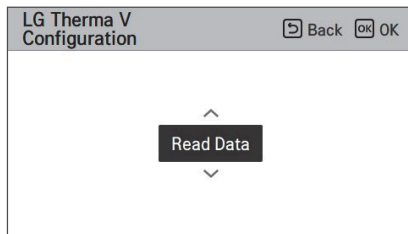
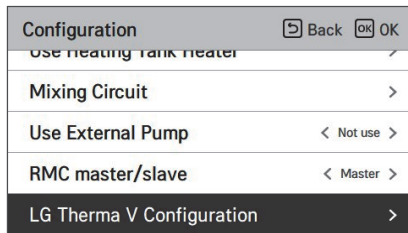
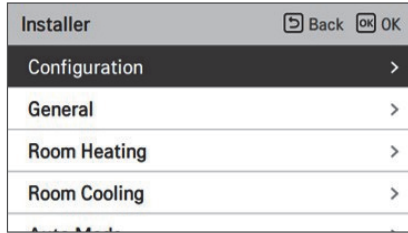

Value	
Read Data (Default)	Save Data

NOTE

When saving the environment settings of the product in the micro SD Card, please be sure to save the file name as "RS3_AWHP_DATA"

Forced operation

- If the product is not used for a long time, the main water pump will be forced to operate for preventing pump failure and PHEX freezing.
- Water pump off After 20 consecutive hours, disable / enable the logic that drives the water pump by itself
- In the installer setting list, select Forced operation category, and press [OK] button to move to the detail screen

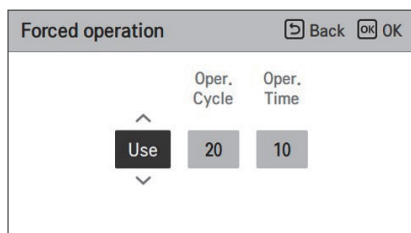
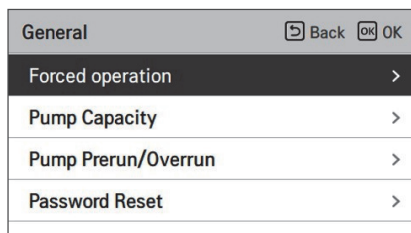
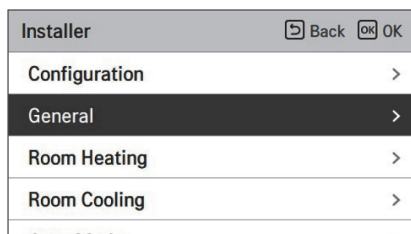

Type	Use (Default)	Not use
Oper. Cycle	20 ~ 180 hours (Default : 20 hours)	-
Oper. Time	1 ~ 10 min (Default : 10 min)	-

Pump Capacity (For Split IWT)

It is a function to enable installer to control the main water pump capacity application model.

- In the installer setting list, select Pump Capacity category, and press [OK] button to move to the detail screen.

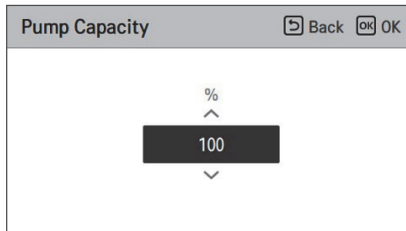
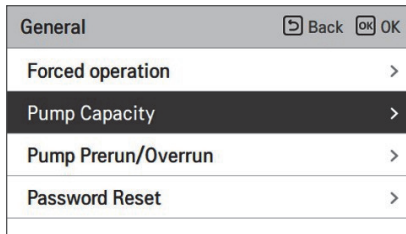
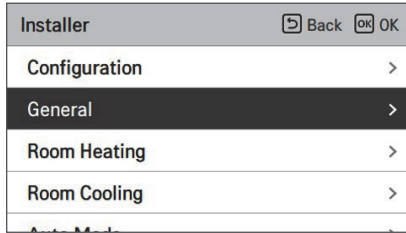

Value	Description
100 (Default)	10~100 : % Change unit: 5

Pump Prerun/Overrun

Pump Prerun operates to ensure sufficient flow before the compressor is operated. This is a function that allows heat exchange to work smoothly.

Pump Overrun is a function to prevent water pump failure and to help mechanical life.

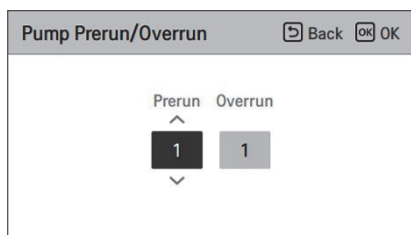
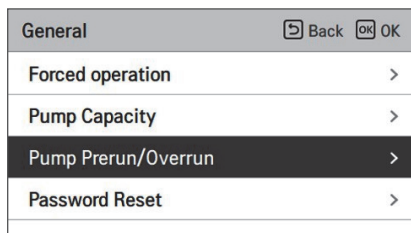
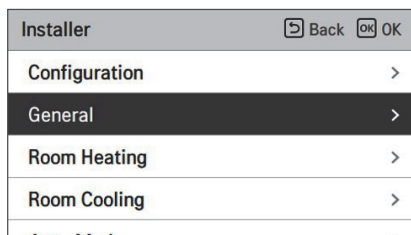

Value	Default	Setting Range
Prerun	1 min	1~10 min
Overrun	1 min	1~10 min

Water Flow Control (For Hydrosplit IWT)

This function controls the water flow by controlling the water pump. Select the way to control the water pump and set the target value

- In the installer setting list, select Configuration category, and press [OK] button to move to the detail screen.
- Optimal Flow Rate
The water pump is automatically controlled at the optimum flow rate required according to the desired temperature of the Main screen.
- Pump Capacity
It operates with the capacity set for the water pump.
- Fixed Flow Rate
The water pump is automatically controlled to maintain the set flow rate.
- Fixed ΔT
Set the target ΔT (* ΔT = temperature difference between inlet and outlet water temperature)
The water pump is automatically controlled to maintain the set ΔT .

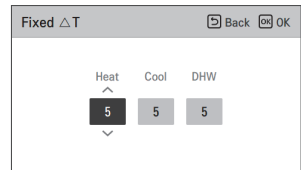
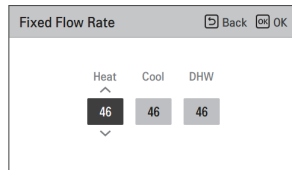
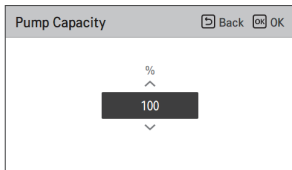
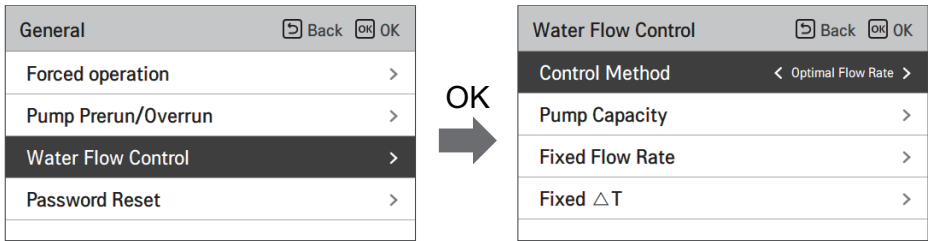

Flow Control Method			
Optimal Flow Rate (Default)	Pump Capacity	Fixed Flow Rate	Fixed ΔT

Password Reset

It is the function to reset (0000) when you forgot the password set in the remote controller.

- In the installer setting list, select the password reset setting category, and press [OK] button to move to the detail screen.
- When you press “reset” button, a popup screen appears, and when you press “check” button, password reset starts, and the user password is changed to 0000.

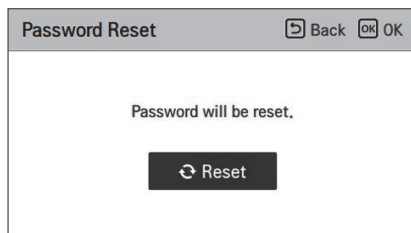
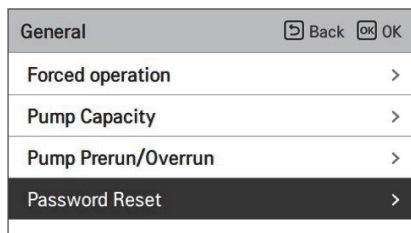
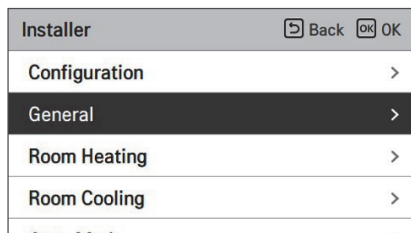

Heating temp. setting

- At the water control in heating mode, the control reference water temperature position setting - If the air / leaving water temperature selection setting is set to leaving water temperature
- Change setting values using [<,>(left/right)] button
- The function is not available for some products.

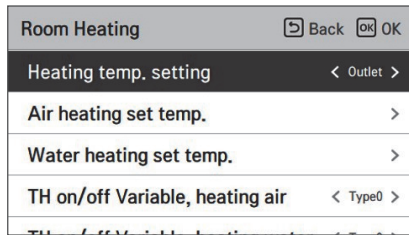
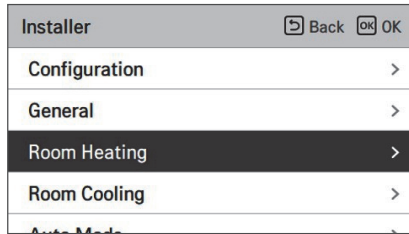

Value	
Outlet (Default)	Inlet

Air heating set temp.

Determine heating setting temperature range when air temperature is selected as setting temperature

- In the installer setting list, select Air heating set temp. category, and press [OK] button to move to the detail screen.

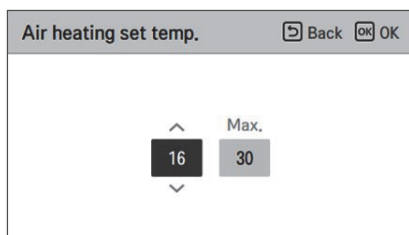
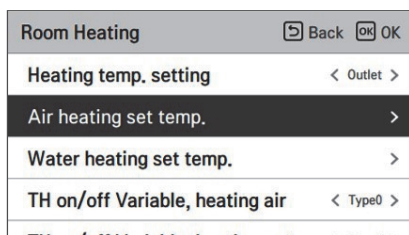
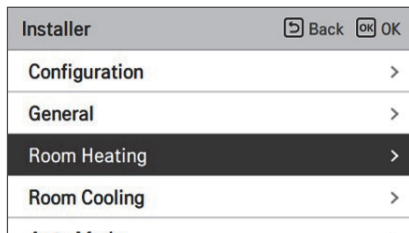

Value	Default	Range
Max.	30	30~24
Min.	16	22~16

* Upper / lower limit / default value is in °C

NOTE

It is possible to control the unit based on room air temperature by using either remote air temperature sensor or wired remote controller (RS3).

- Remote room air sensor is an accessory (PQRSTA0) and sold separately.
- DIP switch setting should be set properly in order to control the unit based on room air temperature.

Water heating set temp

Determine heating setting temperature range when water temperature is selected as setting temperature.

- In the installer setting list, select Water heating set temp. category, and press [OK] button to move to the detail screen.

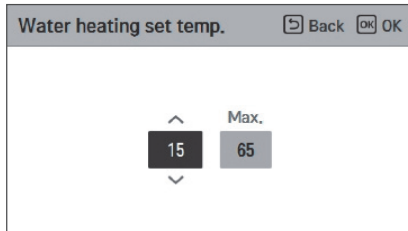
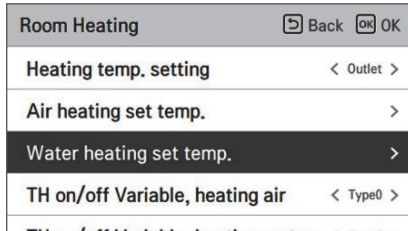
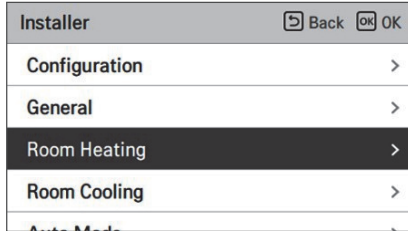

Value		Default	Range
Max.	Outlet	65	65 ~ 35
	Inlet	55	55 ~ 35
Min.	E/heater use	15	34 ~ 15
	E/heater Not use	20	34 ~ 20

* Value is in °C

NOTE

- When the E/heater is not used, the minimum temperature of the water temperature can be set from 34 °C to 20 °C and default value is 20 °C.

TH on/off Variable, heating air (For Split IWT)

It is a function to adjust the heating air temperature Thermal On / Off temperature according to the field environment in order to offer optimized heating operation.

- You can set the following setting values using [<, >(left/right)] button.

Installer	Back OK OK
Configuration	>
General	>
Room Heating	>
Room Cooling	>
Auto Mode	>



Room Heating	Back OK OK
Air heating set temp.	>
Water heating set temp.	>
TH on/off Variable, heating air	< Type0 >
TH on/off Variable, heating water	< Type0 >
Pump setting in heating	>

Value	Description	
	TH On	TH Off
Type0 (Default)	-0.5 °C	1.5 °C
Type1	-1 °C	2 °C
Type2	-2 °C	3 °C
Type3	-3 °C	4 °C

TH on/off Variable, heating water (For Split IWT)

It is a function to adjust the heating water temperature Thermal On / Off temperature according to the field environment in order to offer optimized heating operation.

- You can set the following setting values using [,>](left/right)] button.

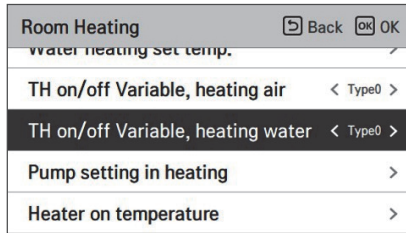
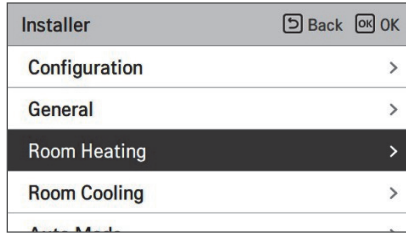

Value	Description	
	TH On	TH Off
Type0 (Default)	-2 °C	2 °C
Type1	-3 °C	3 °C
Type2	-4 °C	4 °C
Type3	-1 °C	1 °C

Hysteresis Heating Water (For Hydrosplit IWT)

It is a function to adjust the heating water temperature Thermal On / Off temperature according to the field environment in order to offer optimized heating operation.

- In the Installer setting list, and select Hysteresis Heating Water category, and press [OK] button to move to the detail screen.

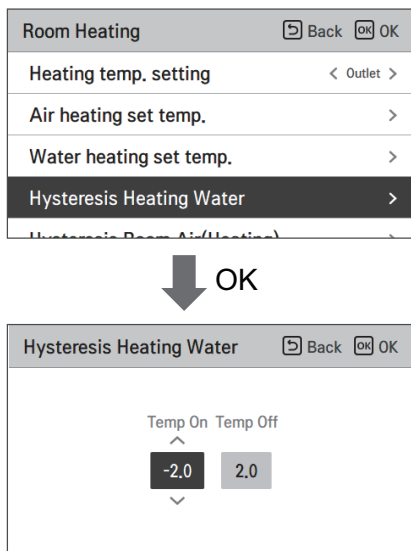

Type	Default	Range
Temp On	-2	0 ~ -9
Temp Off	2	4 ~ 0

Hysteresis Room Air(Heating) (For Hydrosplit IWT)

It is a function to adjust the heating air temperature Thermal On / Off temperature according to the field environment in order to offer optimized heating operation.

- In the Installer setting list, and select Hysteresis Room Air(Heating) category, and press [OK] button to move to the detail screen.

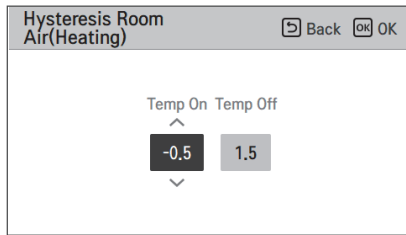
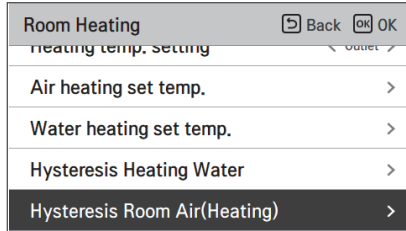

Type	Default	Range
Temp On	-0.5	0 ~ -3
Temp Off	1.5	4 ~ 0

Pump setting in heating

- It is a function to help the water pump's mechanical life by putting the water pump's rest time.
- Installer setting function to set water pump on/off interval option during thermo off condition in heating mode.
- In the installer setting list, select Pump setting in heating category, and press [OK] button to move to the detail screen.

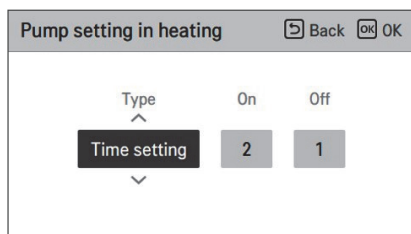
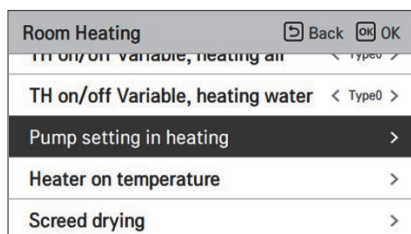
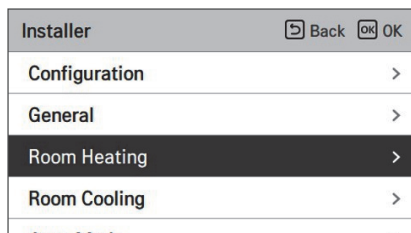

Type	On	Off
Time setting (Default)	1 ~ 60 min (Default : 2 min)	1 ~ 60 min (Default : 1 min)
Operation continue	-	-

Heater on temperature

Depending on local climatic conditions, it is necessary to change the temperature condition in which electric heater turns on / off.

- In the installer setting list, Heater on temperature category, and press [OK] button to move to the detail screen.

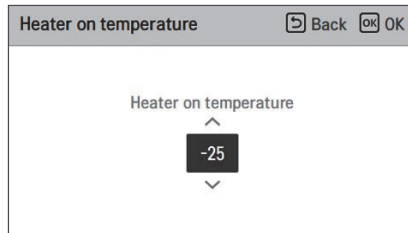
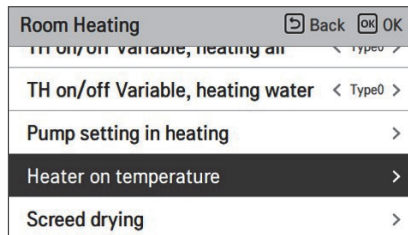
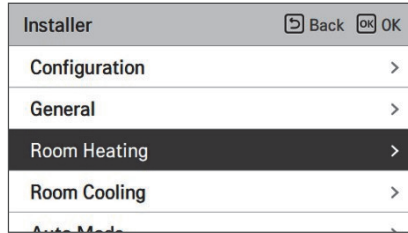

Default	Range
-5	18~-25

* Upper / lower limit / default value is in °C

Screed drying

This function is a unique feature of AWHP that, when AWHP is installed in a new concrete structure, controls the specific temperature floor heating out temperature for a certain period of time to cure the floor cement.

- In the installer setting list, select Screed drying category, and press [OK] button to move to the detail screen.

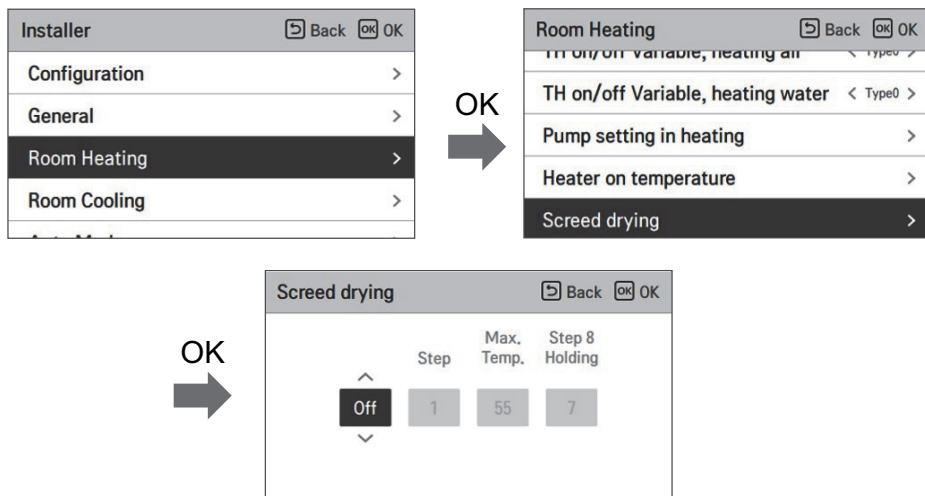

How to display

Main Screen - Displays 'Screed drying' on the desired temperature display. The step in progress at the bottom of the display is displayed.

Setting value

- Start-up step: 1 ~ 11
- Maximum temperature : 35 °C ~ 55 °C (Default : 55 °C)
- Step 8 Holding time : 1 days ~ 30 days (Default : 7 days)

Function operation

- It is performed by the following procedure from the selected starting step.
- After all steps are completed, turn off the cement curing operation.

Step	1	2	3	4	5	6	7	8	9	10	11
Leaving Water target temperature[°C]	25	Max.T	Off	25	35	45	Max.T	Max.T	45	35	25
Duration [hours]	72	96	72	24	24	24	24	Holding time	72	72	72

* If the upper limit setting value of the heating LW temperature is 55 °C or lower, it is set to 55 °C forcibly.

NOTE

- During Screed drying operation, button input except for installer function and temperature display is restricted.
- When the power is applied again after a power outage during product operation, the product operation state before power failure is remembered and the product is automatically operated.
- Screed drying operation stops when an error occurs / When error is cleared, restart cement Screed drying. (However, if the wired remote control is reset to the error occurrence state, it is compensated in the unit of one day)
- Upon releasing after an error, Screed drying operation may take up to 1 minute of waiting time after boot up. (The Screed drying operation status is judged as 1 minute cycle.)
- During Screed drying operation, installer function Screed drying operation is selectable.
- During Screed drying operation, starting operation, low noise mode off, low noise time setting off, hot water off, solar heat off.
- During Screed drying operation, simple, sleep, on, off, weekly, holiday, heater does not execute reservation operation.

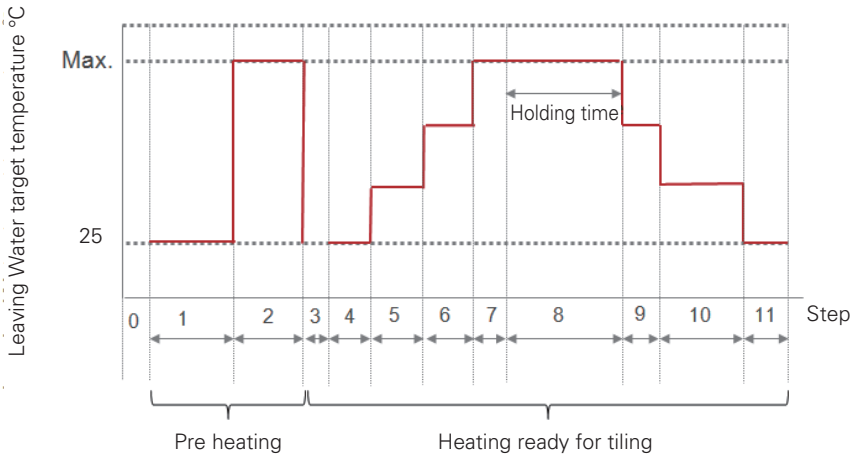

Cooling temp. setting

- At the water control in cooling mode, the control reference water temperature position setting
- If the air / leaving water temperature selection setting is set to leaving water temperature
- Change setting values using [**<**,**>**(left/right)] button.
- The function is not available for some products.

Installer	Back	OK
General		
Room Heating		>
Room Cooling		>
Auto Mode		>
Domestic Hot Water		>



Room Cooling	Back	OK
Cooling temp. setting	< Outlet >	
Air cooling set temp.		>
Water cooling set temp.		>
Water supply off temp. during cooling		>

Value	
Outlet (Default)	Inlet

Air cooling set temp.

Determine cooling setting temperature range when air temperature is selected as setting temperature.

- In the installer setting list, select Air cooling set temp category, and press [OK] button to move to the detail screen.

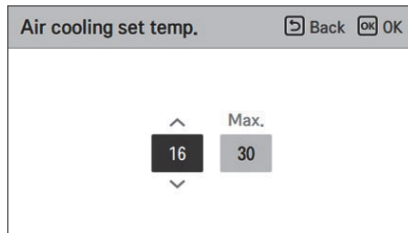
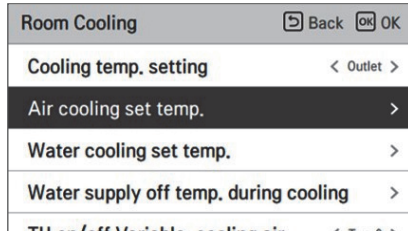
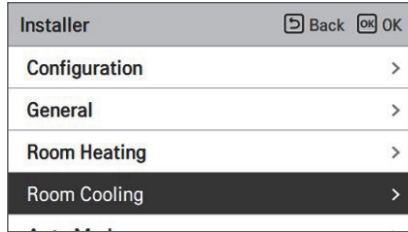

Value	Default	Range
Max.	30	30~24
Min.	18	22~16

* Upper / lower limit / default value is in °C

NOTE

It is possible to control the unit based on room air temperature by using either remote air temperature sensor or wired remote controller (RS3).

- Remote room air sensor is an accessory (PQRSTA0) and sold separately.
- DIP switch setting should be set properly in order to control the unit based on room air temperature.

Water cooling set temp

Determine cooling setting temperature range when water temperature is selected as setting temperature.

- In the installer setting list, select water cooling set temp category, and press [OK] button to move to the detail screen.

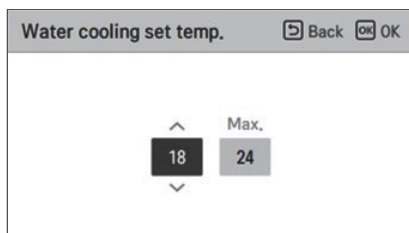
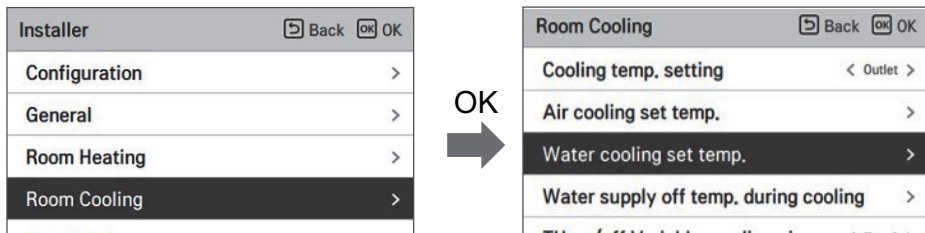

Value		Default	Range	
			Outlet	Inlet
Max.		24	22~27	22~27
Min.	FCU use	5	5~20	10~20
	FCU Not use	16	16~20	20

* Value is in °C

* When set to inlet temperature, the default value of Min. temp is set to the minimum value that can be set.

NOTE

Water condensation on the floor

- While cooling operation, it is very important to keep leaving water temperature higher than 16 °C. Otherwise, dew condensation can be occurred on the floor.
- If floor is in humid environment, do not set leaving water temperature below 18 °C.

NOTE

Water condensation on the radiator

- While cooling operation, cold water may not flow to the radiator. If cold water enters to the radiator, dew generation on the surface of the radiator can be occurred.

Water supply off temp. during cooling

Determine the leaving water temperature which blocks the flow into underfloor coil in cooling mode. This function is used for preventing condensation on the floor in cooling mode

- In the installer setting list, select Water supply off temp. during cooling category, and press [OK] button to move to the detail screen.

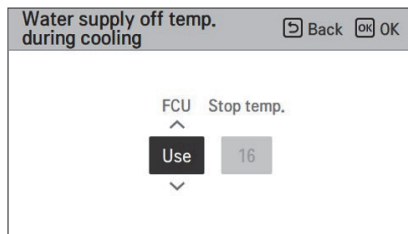
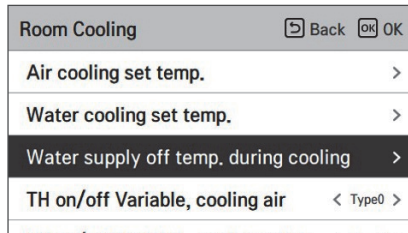
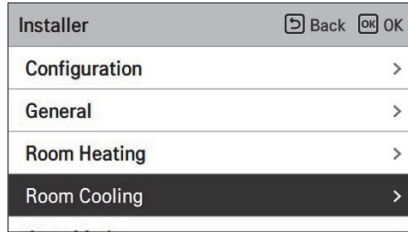

Value	Default	Setting Range
FCU	Use	Use / Not use
Stop temp.	16	25 ~ 16

* Value is in °C

NOTE

- If the FCU is not used, the stop temp. cannot be set.
- Depending on FCU setting, the water cooling set temperature range is adjusted.

- Stop temp. : cut-off temperature. Stop temp. is valid when FCU is installed.
- FCU : determines if FCU is installed or not.
- Example : If FCU is set as 'Use', Stop temp. setting is disabled. However, if actually FCU is NOT installed in the water loop, the unit operates continuously in cooling mode until water temperature meets desired temperature. In this case, a condensed water may form on the floor caused by cold water in the underfloor coil.
- Example : If Stop temp. is set as '20' and FCU is set as 'Not use' and actually FCU is installed in the water loop, then the Stop temp. is used and the unit stops operation in cooling mode when the leaving water temperature is below 20 °C. As a result, the unit may not offer enough cooling since the cold water with desired temperature doesn't flow into the FCU.



CAUTION

FCU Installation

- If FCU is used, related 2way valve should be installed and connected to the Main PCB assembly 1.
- If FCU is set as 'Use' whereas FCU or 2way valve is NOT installed, the unit can do abnormal operation.

TH on/off Variable, cooling air (For Split IWT)

It is a function to adjust the cooling air temperature Thermal On / Off temperature according to the field environment in order to offer optimized heating operation.

- You can set the following setting values using [**<**,**>**(left/right)] button.

Installer	Back OK
General	>
Room Heating	>
Room Cooling	>
Auto Mode	>
Domestic Hot Water	>



Room Cooling	Back OK
water cooling set temp.	>
Water supply off temp. during cooling	>
TH on/off Variable, cooling air	< Type0 >
TH on/off Variable, cooling water	< Type0 >
Pump setting in cooling	>

Value	Description	
	TH On	TH Off
Type0 (Default)	0.5 °C	-0.5 °C
Type1	1 °C	-1 °C
Type2	2 °C	-2 °C
Type3	3 °C	-3 °C

TH on/off Variable, cooling water (For Split IWT)

It is a function to adjust the cooling water temperature Thermal On / Off temperature according to the field environment in order to offer optimized heating operation.

- You can set the following setting values using [<, >] (left/right) button.

Installer	Back	OK
General		✓
Room Heating		>
Room Cooling		>
Auto Mode		>
Domestic Hot Water		>



Room Cooling	Back	OK
water cooling set temp.		✓
Water supply off temp. during cooling		>
TH on/off Variable, cooling air	< Type0 >	
TH on/off Variable, cooling water	< Type0 >	
Pump setting in cooling		>

Value	Description	
	TH On	TH Off
Type0 (Default)	0.5 °C	-0.5 °C
Type1	1 °C	-1 °C
Type2	2 °C	-2 °C
Type3	3 °C	-3 °C

Hysteresis Cooling Water (For Hydrosplit IWT)

It is a function to adjust the cooling water temperature Thermal On / Off temperature according to the field environment in order to offer optimized cooling operation.

- In the Installer setting list, and select Hysteresis Cooling Water setting category, and press [OK] button to move to the detail screen.

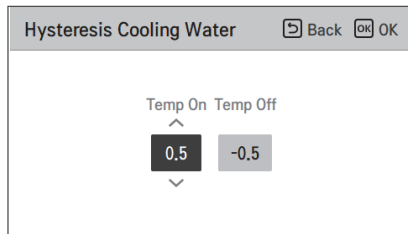
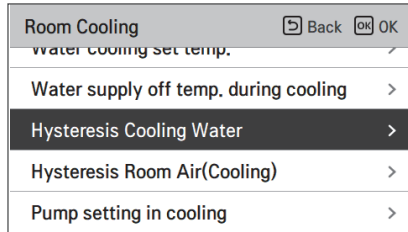

Type	Default	Range
Temp On	0.5	3 ~ 0
Temp Off	-0.5	0 ~ -3

Hysteresis Room Air(Cooling) (For Hydrosplit IWT)

It is a function to adjust the cooling air temperature Thermal On / Off temperature according to the field environment in order to offer optimized cooling operation.

- In the Installer setting list, and select Hysteresis Room Air(Cooling) setting category, and press [OK] button to move to the detail screen.

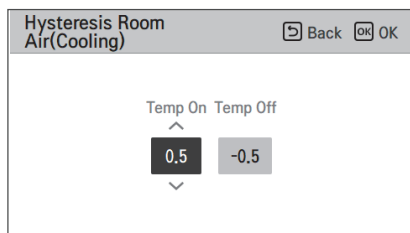
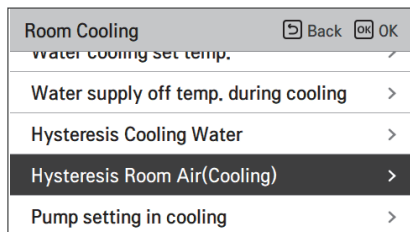

Type	Default	Range
Temp On	0.5	3 ~ 0
Temp Off	-0.5	0 ~ -3

Pump setting in cooling

- It is a function to help the water pump's mechanical life by putting the water pump's rest time.
- Installer setting function to set water pump on/off interval option during thermo off condition in cooling mode.
- In the installer setting list, select Pump setting in cooling category, and press [OK] button to move to the detail screen.

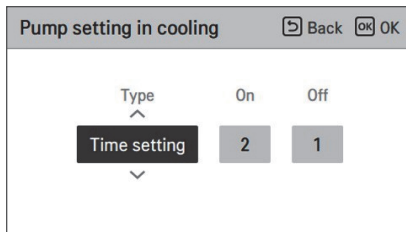
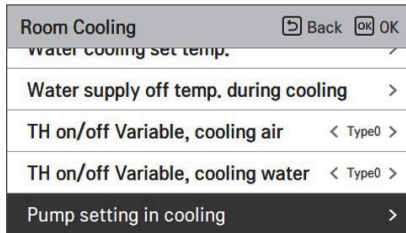
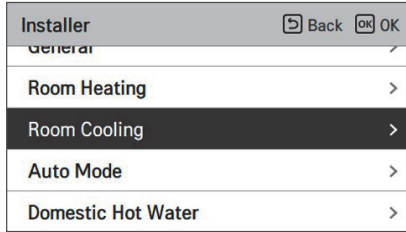

Type	On	Off
Time setting (Default)	1 ~ 60 min (Default : 2 min)	1 ~ 60 min (Default : 1 min)
Operation continue	-	-

Seasonal auto temp. (For Split IWT)

It is the function to set the operation reference value in Seasonal Auto mode.

- In the installer setting list, select Seasonal auto temp category, and press [OK] button to move to the detail screen.

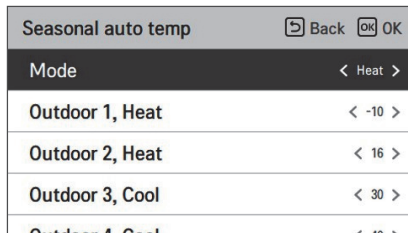
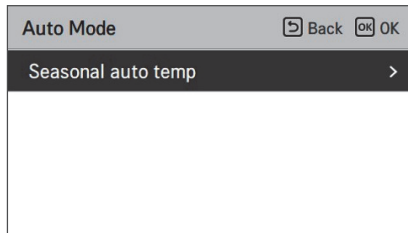
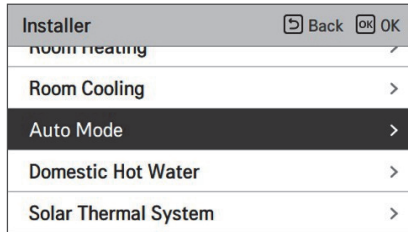

Function	Description	Range	Default	Boundary
Outdoor1,Heat (Out1)	Heating lower ambient temp	-25 ~ 35 °C	-10 °C	Out1 ≤ Out2-1
Outdoor2,Heat (Out2)	Heating higher ambient temp		16 °C	Out2 ≥ Out1 +1 Out2 ≤ Out3 -5
Outdoor3,Cool (Out3)	Cooling lower ambient temp	10 ~ 46 °C	30 °C	Out3 ≥ Out2 +5 Out3 ≤ Out4 -1
Outdoor4,Cool (Out4)	Cooling higher ambient temp		40 °C	Out4 ≥ Out3 +1
Water1,Heat (LW1)	Heating higher water temp	Use heater : LW STD : 15~65 °C EW STD : 15~55 °C Not use heater : LW STD : 20~65 °C EW STD : 20~55 °C	35 °C	LW1 ≥ LW2
Water 2,Heat (LW2)	Heating lower water temp		28 °C	LW1 ≥ LW2
Water3,Cool (LW3)	Cooling higher water temp	Use FCU & 5 °C IDU : LW STD : 5~27 °C EW STD : 10~27 °C Use FCU & 6 °C IDU : LW STD : 6~27 °C EW STD : 11~27 °C Not use FCU : LW STD : 16~27 °C EW STD : 20~27 °C	20 °C	LW3 ≥ LW4
Water4,Cool (LW4)	Cooling lower water temp		16 °C	LW3 ≥ LW4
Air 1, Heat (RA1)	Heating higher air temp	16 ~ 30 °C	30 °C	RA1 ≥ RA2
Air 2, Heat (RA2)	Heating lower air temp		26 °C	RA1 ≥ RA2
Air 3, Cool (RA3)	Cooling higher air temp	18(16) ~ 30 °C	22 °C	RA3 ≥ RA4
Air 4, Cool (RA4)	Cooling lower air temp		18 °C	RA3 ≥ RA4

- Setting range: Celsius

- Seasonal Auto Driving mode: Heating, Heating & Cooling, Cooling

* If heating mode is selected, heating & cooling or cooling can not be selected.

- Depending on the air / outflow control selection value, the water / air related setting value is displayed on the screen (seasonal auto temp).

Seasonal auto temp. (For Hydrosplit IWT)

It is the function to set the operation reference value in Seasonal Auto mode.

- In the installer setting list, select Seasonal auto temp category, and press [OK] button to move to the detail screen.

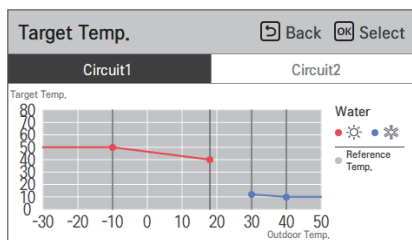
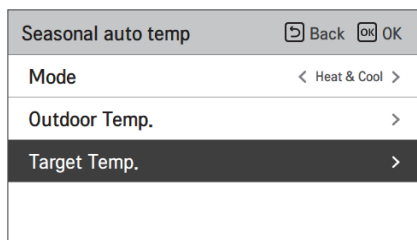
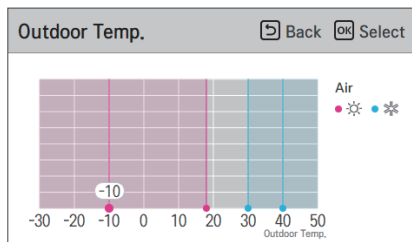
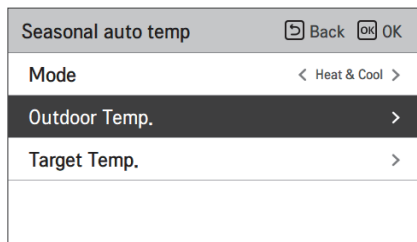
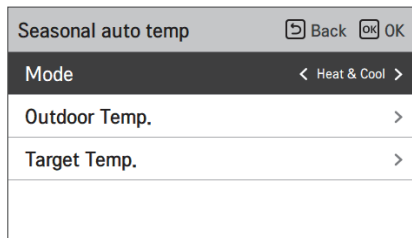
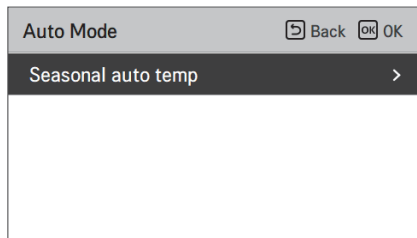

Function	Description	Range	Default (Circuit1)	Default (Circuit2)	Boundary
Outdoor1,Heat (Out1)	Heating lower ambient temp	-25 ~ 35 °C	-10 °C		Out1 ≤ Out2-1
Outdoor2,Heat (Out2)	Heating higher ambient temp		18 °C		Out2 ≥ Out1 +1 Out2 ≤ Out3 -5
Outdoor3,Cool (Out3)	Cooling lower ambient temp	10 ~ 46 °C	30 °C		Out3 ≥ Out2 +5 Out3 ≤ Out4 -1
Outdoor4,Cool (Out4)	Cooling higher ambient temp		40 °C		Out4 ≥ Out3 +1
Water1,Heat (LW1)	Heating higher water temp	Use heater : LW STD : 15~65 °C EW STD : 15~55 °C Not use heater : LW STD : 20~65 °C EW STD : 20~55 °C	50 °C	35 °C	LW1 ≥ LW2
Water 2,Heat (LW2)	Heating lower water temp		40 °C	28 °C	LW1 ≥ LW2
Water3,Cool (LW3)	Cooling higher water temp	Use FCU & 5 °C IDU : LW STD : 5~27 °C EW STD : 10~27 °C Use FCU & 6 °C IDU : LW STD : 6~27 °C EW STD : 11~27 °C Not use FCU : LW STD : 16~27 °C EW STD : 20~27 °C	12 °C	18 °C	LW3 ≥ LW4
Water4,Cool (LW4)	Cooling lower water temp		10 °C	16 °C	LW3 ≥ LW4
Air 1, Heat (RA1)	Heating higher air temp	16 ~ 30 °C	21 °C		RA1 ≥ RA2
Air 2, Heat (RA2)	Heating lower air temp		19 °C		RA1 ≥ RA2
Air 3, Cool (RA3)	Cooling higher air temp	18 ~ 30 °C	21 °C		RA3 ≥ RA4
Air 4, Cool (RA4)	Cooling lower air temp		19 °C		RA3 ≥ RA4

- Setting range: Celsius

- Seasonal Auto Driving mode: Heating, Heating & Cooling

* If heating mode is selected, heating & cooling or cooling can not be selected.

- Depending on the air / outflow control selection value, the water / air related setting value is displayed on the screen (seasonal auto temp) .

DHW set temp

Determine heating setting temperature range when DHW temperature is selected as setting temperature

- In the installer setting list, select DHW set temp. category, and press [OK] button to move to the detail screen.

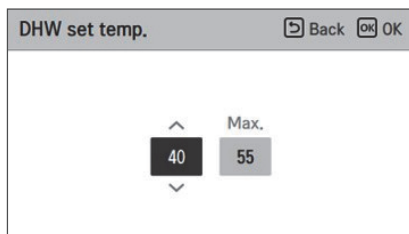
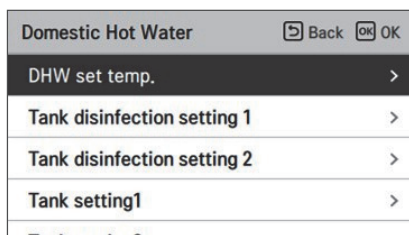
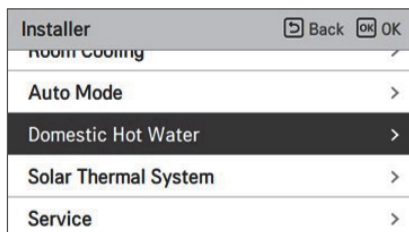

Value	Default	Range
Max.	55	80~50
Min.	40	40~30

* Upper / lower limit / default value is in °C

Tank disinfection setting 1, 2

- Disinfection operation is special DHW tank operation mode to kill and to prevent growth of legionella inside the tank.
 - Disinfection active : Selecting enable or disable of disinfection operation.
 - Start date : Determining the date when the disinfection mode is running.
 - Start time : Determining the time when the disinfection mode is running.
 - Max temp. : Target temperature of disinfection mode.
 - Duration time : Duration of disinfection mode.

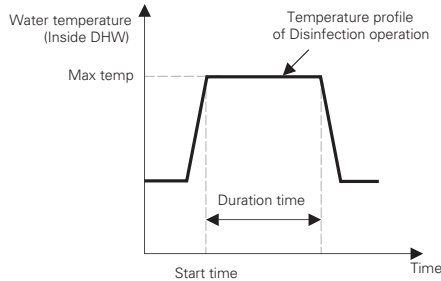

- In the installer setting list, select 'Domestic Hot Water' category, and press [OK] button to move to the tank disinfection setting screen.

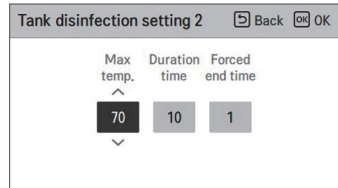
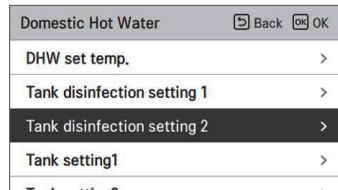
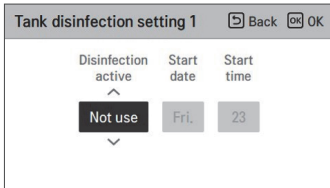
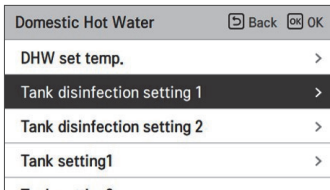

Value	Default	Range
Disinfection active	Not use	Use / Not use
Start date	Fri.	Mon. ~ Sun.
Start time	23	23 ~ 00

Value	Default	Range
Max temp.	70	60 ~ 80
Duration time	10	60 ~ 5 (Change unit: 5)
Forced and time	1	1 ~ 12

NOTE

DHW heating should be enable

- If Disinfection active is set as 'Not use', that is 'disable disinfection mode', Start date and Start time is not used.

Tank setting 1

- In the installer setting list, select tank setting 1 category, and press [OK] button to move to the detail screen.

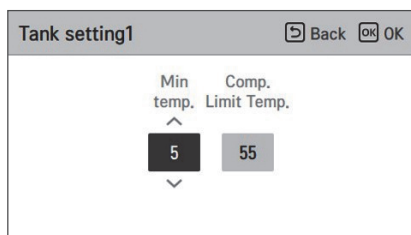
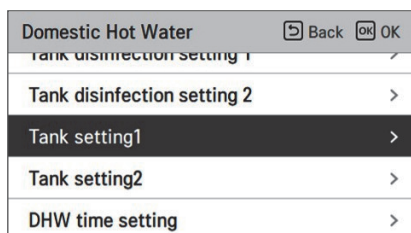
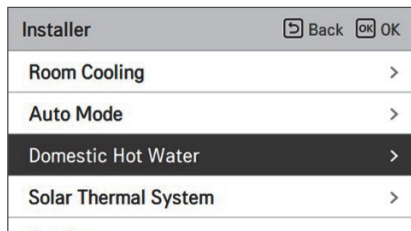

Value	Default	Range
Min temp	5 °C	30 ~ 1 °C
Comp. Limit Temp	55 °C	58 ~ 40 °C

Tank setting 2

- In the installer setting list, select tank setting 2 category, and press [OK] button to move to the detail screen.

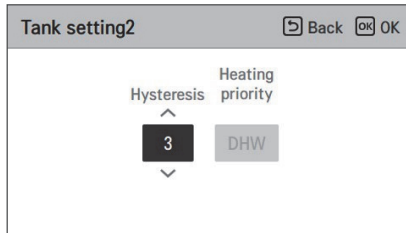
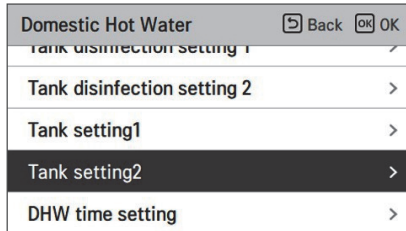
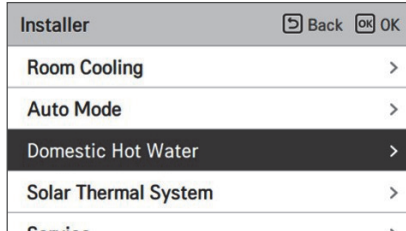

Value	Default	Range
Hysteresis	3 °C	4 ~ 2 °C

NOTE

The Heating priority in IWT products is always 'DHW'.

• Tank setting 1, 2

Descriptions for each parameters are as following.

- Min temp. : temperature gap from Max outdoor temp.
- Comp. Limit Temp. : maximum temperature generated by AWHP compressor cycle.
- Example : If Min temp. is set as '5' and Comp. Limit Temp. is set as '48', then Session A (see the graph) will be started when the water tank temperature is below 43 °C.... If temperature is above 48 °C..., then Session B will be started.
- Hysteresis : temperature gap from target DHW temperature. This value is required to prevent frequent On and Off of electric heater.
- Example : If user's target temperature is set as '70' and Hysteresis is set as '3', then the electric heater will be turned off when the water temperature is above 73 °C. The electric heater will be turned on when the water temperature is below 70 °C.
- Example : If Heating priority is set as 'DHW', that means heating priority is on DHW heating, DHW is heated by AWHP compressor cycle and electric heater. In this case the under floor can not be heated while DHW heating. On the other hand, if the Heating priority is set as 'Floor heating', that means heating priority is on under floor heating, DHW tank is ONLY heated by electric heater. In this case the under floor heating is not stopped while DHW is heated.

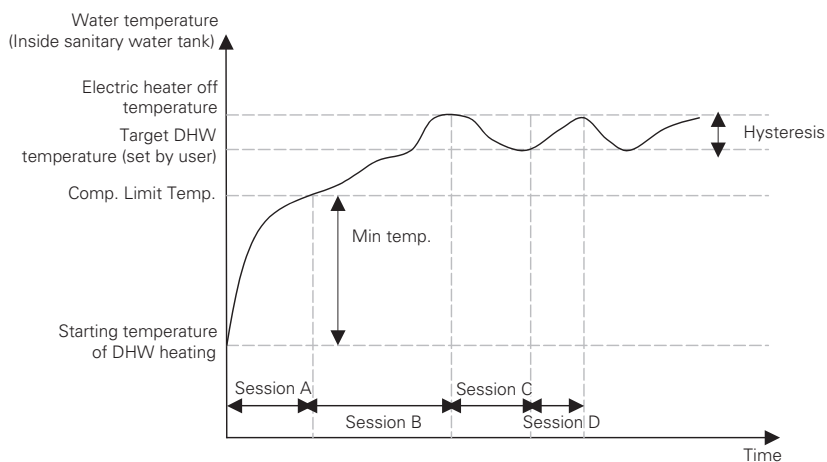

- Session A : Heating by AWHP compressor cycle and electric heater
- Session B : Heating by electric heater
- Session C : No heating (Electric heater is Off)
- Session D : Heating by electric heater

NOTE

DHW heating does not operate when it is disabled.

DHW time setting

Determine following time duration : operation time of DHW tank heating, stop time of DHW tank heating, and delay time of DHW tank heater operating.

- Active time : This time duration defines how long time DHW tank heating can be continued.
- Stop time : This time duration defines how long time DHW tank heating can be stopped. It is also regarded as time gap between DHW tank heating cycle.
- Electric heater delay time : This time duration defines how long time electric heater will not be turned on in DHW heating operation. The electric heater delay time setting can be set in the **'Use Heating Tank Heater'** category.
- Example of timing chart :

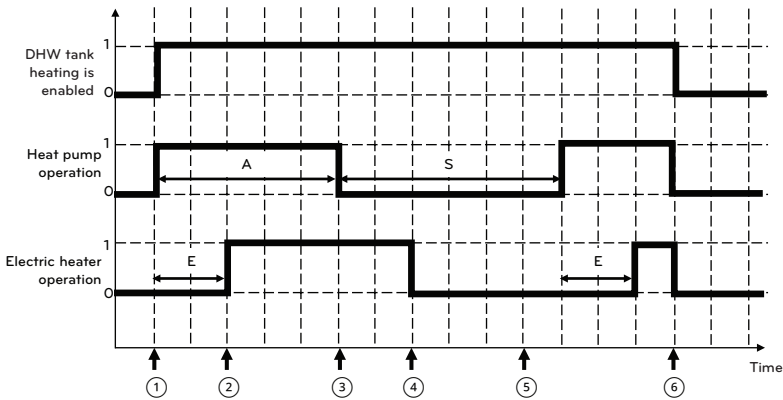

- * 1=active / 0=not active
- * A = Active time
- * S = Stop time
- * E = Electric heater delay time

①	Heat pump ON condition
②	Electric heater starts after delay time, if heat pump has not reached target temperature yet
③	Heat pump OFF even if hot water target is not reached
④	Hot water heating interrupted (Heat pump may commence with Heating or Cooling during Stop time)
⑤	Hot water heating re-starts
⑥	DHW heating is disabled (by reaching target temperature or by schedule or manually)

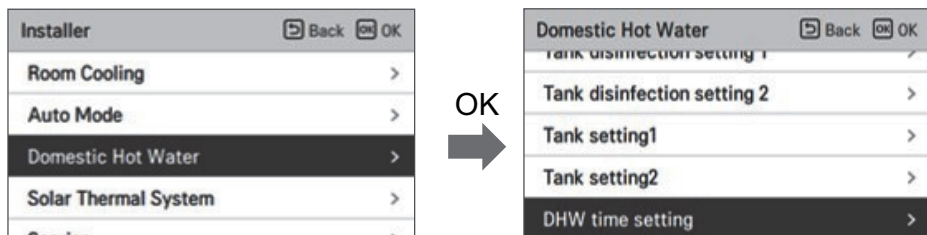

Value	Default	Range
Active time	30 min	5~95 min
Stop time	30 min	0~600 min

Pump test run

The pump test run is the function to test run by operating the main water pump for one hour. This function can be used for air vents / flow sensors and others.

- In the installer setting list, Pump Test run category, and press [OK] button to move to the detail screen.

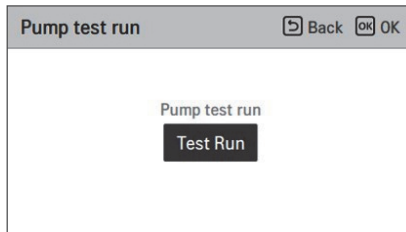
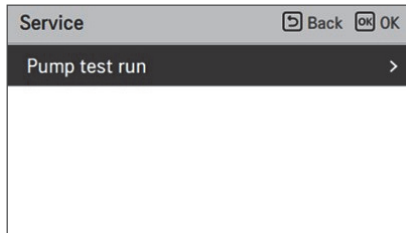
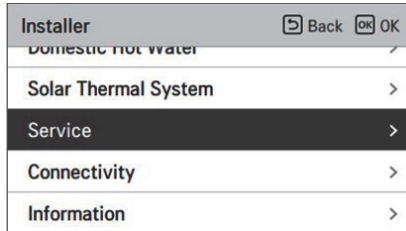

Frost Protection Temp.

Frost protection temperature setting is available in installer mode. It prevents frostbite from happening in the range of -25 to -5 degree celsius.

- Change setting values using [**<**, **>**(left/right)] button.

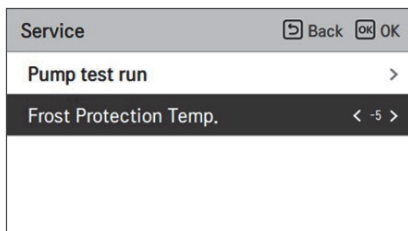
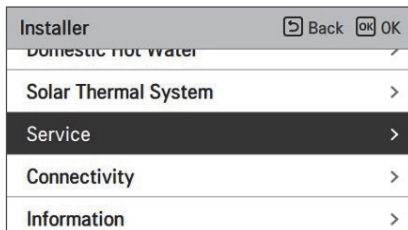

Default	Value
-5	-5 / -10 / -15 / -20 / -25

(For Split IWT)

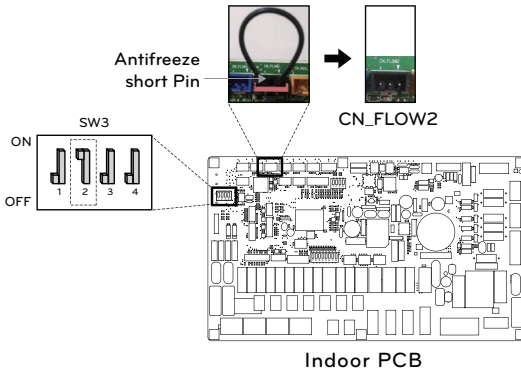

NOTE

To use this function, the antifreeze short pin(CN_FLOW2) must be open and switch No.2 in Option SW 3 must be on.

(For Hydrosplit IWT)

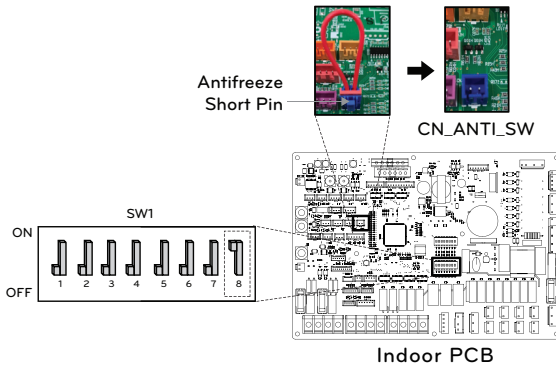

NOTE

To use this function, the antifreeze short pin (CN_ANTI_SW) must be open and Switch No.8 in option SW1 must be on.

Dry Contact Mode

Dry contact function is the function that can be used only when the dry contact devices is separately purchased and installed.

- Change setting values using [<,>(left/right)] button.
- Setting up operation status when dry contact on
 - Auto : Automatically, Operation ON with release hard lock
 - Manual : Keep Operation OFF with release hard lock
- ※ Dry contact Off : Operation Off + Hard Lock

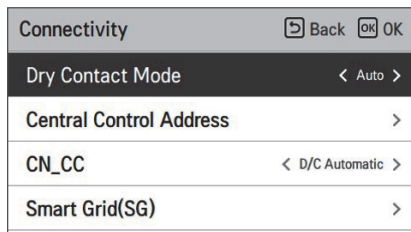
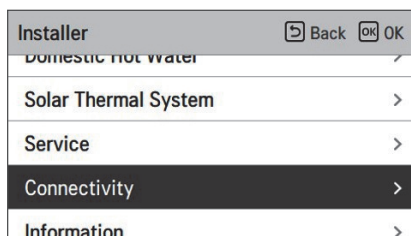

Value
Auto (Default)
manual

NOTE

For dry contact mode related detail functions, refer to the individual dry contact manual.

What is dry contact?

It means the contact point signal input when the hotel card key, human body detection sensor, etc. are interfacing with the unit.

Added system functionality by using external inputs (dry contacts and wet contacts).

Central Control Address

When connecting the central control, set the central control address of the unit.

- In the installer setting list, select Central Control Address category, and press [OK] button to move to the detail screen.

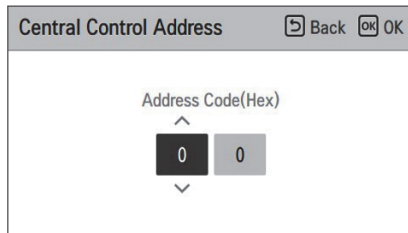
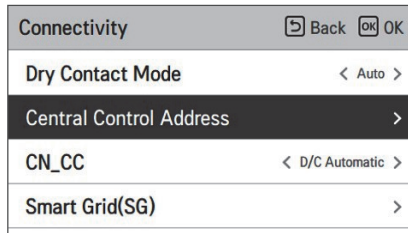
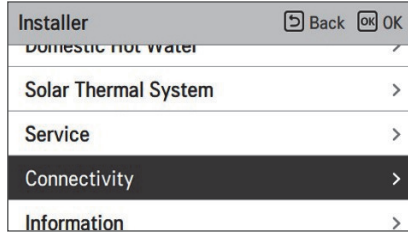

NOTE

Enter address code as hexadecimal value

Front: Central Control Gr. No.

Back side: Central control indoor the number

CN_CC

It is the function to set the usage of the unit's CN_CC port.

- Change setting values using [<,>(left/right)] button

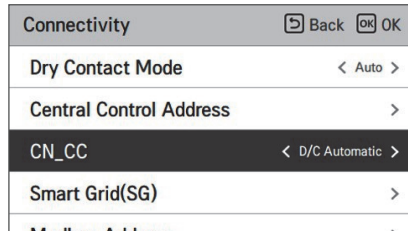
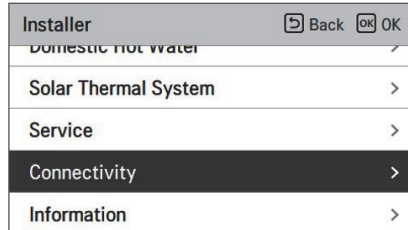

Value	Description
D/C Automatic (Default)	When power is applied to the product, the unit when the contact point is on in Dry Contact installed state recognizes Dry Contact installation
D/C Not Installed	Do not use (install) Dry Contact
D/C Installed	Use (install) Dry Contact

NOTE

CN_CC is the device connected to the unit to recognize and control the external contact point.

Smart Grid (SG) (For Split IWT)

It is the function to enable / disable the Smart Grid function and to set the reference value at SG2 status.

- In the installer setting list, select Smart Grid(SG) category, and press [OK] button to move to the detail screen.

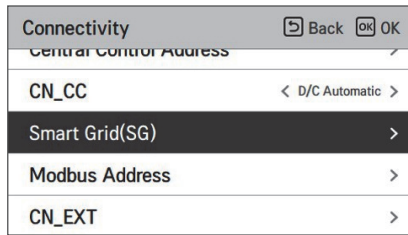
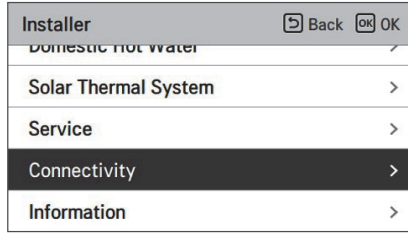

Value	Mode
Not use (Default)	-
Use	Step 0
	Step 1
	Step 2

Power Supply Blockage (Smart Grid) (For Split IWT)

The heat pump operated automatically by the power supply status signals from power supply companies. This function can respond to European countries' special tariff for heat pump using on a smart grid.

4 modes
depending on
power supply status

Power Supply Status



Operating Mode

0:0 [Normal Operation]

The heat pump works at maximum efficiency.

1:0 [Switch-off command, Utility lock]

Deactivates the heat pump to avoid peak load. The maximum blocking time depends on the system's thermal storage capacity, but amounts to at least 2 hours 3 times a day. (No frost protection)

0:1 [Switch-on recommendation]

The switch-on recommendation and set value storage tank temperature is increased, depending on the parameter "Mode SG"

Mode SG : set temperature + α
depending on the below
parameter

Step 0 (DHW +5 °C)

Step 1 (H/P+2 °C, DHW +5 °C)

Step 2 (H/P+5 °C, DHW +7 °C)

1:1 [Switch-on command]

The command activates the compressor. Optionally, electric heater can be activated to utilize electricity surpluses.

Modbus Address

It is function to set the address of the Modbus device that is externally linked to the product. Modbus address setting function is available from indoor unit.

- In the installer setting list, select Modbus Address , and press [OK] button to move to the detail screen.

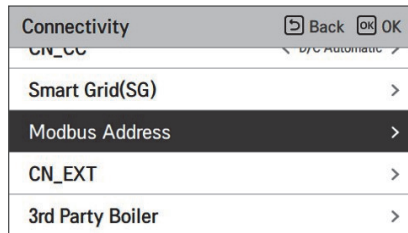
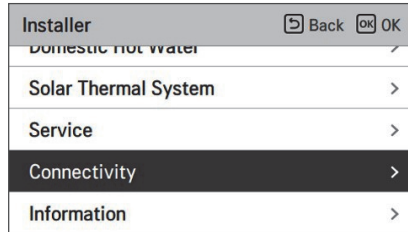

NOTE

To use this function, switch No.1 of option switch 1 must be turned ON.

Modbus gateway memory map (For Hydrosplit IWT)

NOTE

In case of Split IWT, RTU Gateway should be installed for using modbus and refer to the RTU Gateway installation manual for memory maps.

Baud Rate : 9 600 bps Stop Bit : 1 stop bit Parity : None Parity

Coil Register (0x01)

Register	Description	Value explanation
00001	Enable/Disable (Heating/Cooling)	0 : Operation OFF / 1 : Operation ON
00002	Enable/Disable (DHW)	0 : Operation OFF / 1 : Operation ON
00003	Silent Mode Set	0 : Silent mode OFF / 1 : Silent mode ON
00004	Trigger Disinfection operation	0 : Keep status / 1 : Operation start
00005	Emergency Stop	0 : Normal operation / 1 : Emergency stop
00006	Trigger Emergency Operation	0 : Keep status / 1 : Operation Start

Discrete Register (0x02)

Register	Description	Value explanation
10001	Water flow status	0 : Flow rate ok / 1 : Flow rate too low
10002	Water Pump status	0 : Water Pump OFF / 1 : Water Pump ON
10003	Ext. Water Pump status	0 : Water Pump OFF / 1 : Water Pump ON
10004	Compressor status	0 : Compressor OFF / 1 : Compressor ON
10005	Defrosting status	0 : Defrost OFF / 1 : Defrost ON
10006	DHW heating status (DHW Thermal On/Off)	0 : DHW inactive / 1 : DHW active
10007	DHW Tank disinfection status	0 : Disinfection inactive / 1 : Disinfection active
10008	Silent mode status	0 : Silent mode inactive / 1 : Silent mode active
10009	Cooling status	0 : No cooling / 1 : Cooling operation
10010	Solar pump status	0 : Solar pump OFF / 1 : Solar pump ON
10011	Backup heater (Step 1) status	0 : OFF / 1 : ON
10012	Backup heater (Step 2) status	0 : OFF / 1 : ON
10013	DHW boost heater status	0 : OFF / 1 : ON
10014	Error status	0 : no error / 1 : error state
10015	Emergency Operation Available (Space heating/cooling)	0 : Unavailable / 1 : Available
10016	Emergency Operation Available (DHW)	0 : Unavailable / 1 : Available
10017	Mix pump status	0 : Mix pump OFF / 1 : Mix pump ON

Holding Register (0x03)

Register	Description	Value explanation
40001	Operation Mode	0 : Cooling / 4 : Heating / 3 : Auto
40002	Control method (Circuit 1/2)	0 : Water outlet temp. control 1 : Water inlet temp. control 2 : Room air control
40003	Target temp (Heating/Cooling) Circuit 1	[0.1 °C ×10]
40004	Room Air Temp. Circuit 1	[0.1 °C ×10]
40005	Shift value(Target) in auto mode Circuit 1	1K
40006	Target temp (Heating/Cooling) Circuit 2	[0.1 °C ×10]
40007	Room Air Temp. Circuit 2	[0.1 °C ×10]
40008	Shift value(Target) in auto mode Circuit 2	1K
40009	DHW Target temp.	[0.1 °C ×10]
40010	Energy state input	0 : Not Use 1 : Forced off (equal to TB_SG1=close / TB_SG2=open) 2 : Normal operation (equal to TB_SG1=open / TB_SG2=open) 3 : On-recommendation (equal to TB_SG1=open / TB_SG2=close) 4 : On-command (equal to TB_SG1=close / TB_SG2=close) 5 : On-command step 2 (++) Energy Consumption compared to Normal) 6 : On-recommendation Step 1 (+ Energy Consumption compared to Normal) 7 : Energy Saving mode (- Energy Consumption compared to Normal) 8 : Super Energy saving mode (- Energy Consumption compared to Normal)

Input Register (0x04)

Register	Description	Value explanation
30001	Error Code	Error Code
30002	ODU operation Cycle	0 : Standby(OFF) / 1 : Cooling / 2 : Heating
30003	Water inlet temp.	[0.1 °C ×10]
30004	Water outlet temp.	[0.1 °C ×10]
30005	Backup heater outlet temp.	[0.1 °C ×10]
30006	DHW tank water temp.	[0.1 °C ×10]
30007	Solar collector temp.	[0.1 °C ×10]
30008	Room air temp. (Circuit 1)	[0.1 °C ×10]
30009	Current Flow rate	[0.1 LPM ×10]
30010	Flow temp. (Circuit 2)	[0.1 °C ×10]
30011	Room air temp. (Circuit 2)	[0.1 °C ×10]
30012	Energy State input	0 : Energy state 0; 1: Energy state 1...
30013	Outdoor Air temp.	[0.1 °C ×10]
39998	Product Group	0x8X (0x80, 0x83, 0x88, 0x89)
39999	Product Info.	Split : 0 / Monobloc : 3 / High Temp. : 4 / Medium Temp. : 5 / System Boiler : 6

CN_EXT

It is a function to control external input and output according to DI type set by customer using CN-EXT Port.

- In the installer setting list, select CN-EXT Port category, and press [OK] button to move to the detail screen.

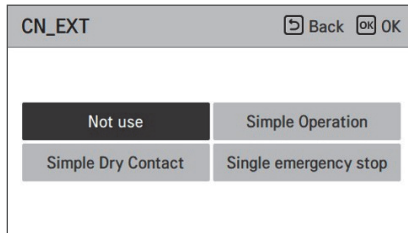
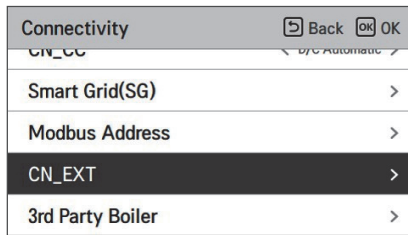
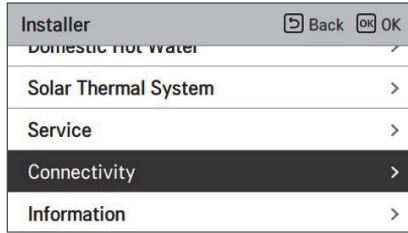

Value			
Not use (Default)	Simple Operation	Simple Dry Contact	Single emergency stop

3rd Party Boiler

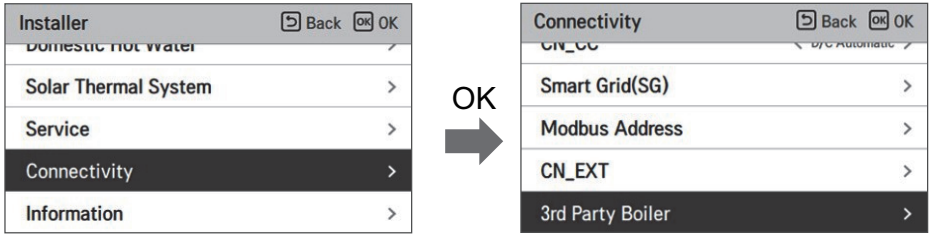

This function is to configure the 3rd party boiler to be controlled.

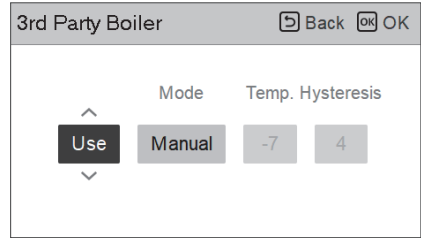
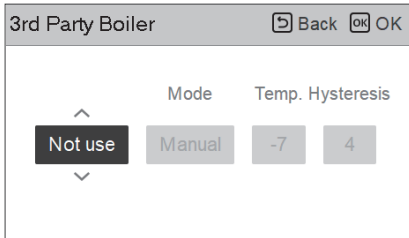

If the status of this function is "Use", you can choose control mode of boiler, Auto or Manual.

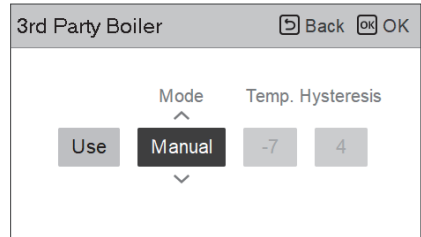
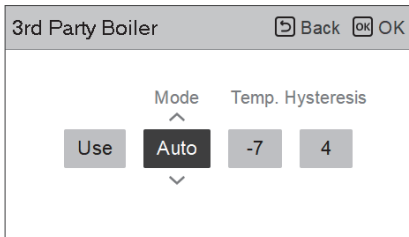

If the mode of this function is set to "Auto", you can set temperature of the boiler and hysteresis, respectively.

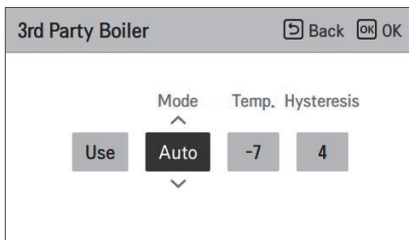

Value	Default	Range
Temp.	-7	-25 ~ 25
Hysteresis	7	2 ~ 10

External boiler ON condition :

- If outdoor temperature \leq external boiler operation temperature value (installer setting), turn off the indoor unit and operate the external boiler.

External boiler OFF condition :

- If External air temperature \geq external boiler operation temperature value (installer setting) + Hysteresis (installer setting), turn off external boiler operation and operate indoor unit

Meter Interface

It is the function that can check the status of energy and power on screen. It collects and calculates power or calorie data to create data for energy monitoring and energy warning alarm pop-ups. This function can be activated in installer mode.

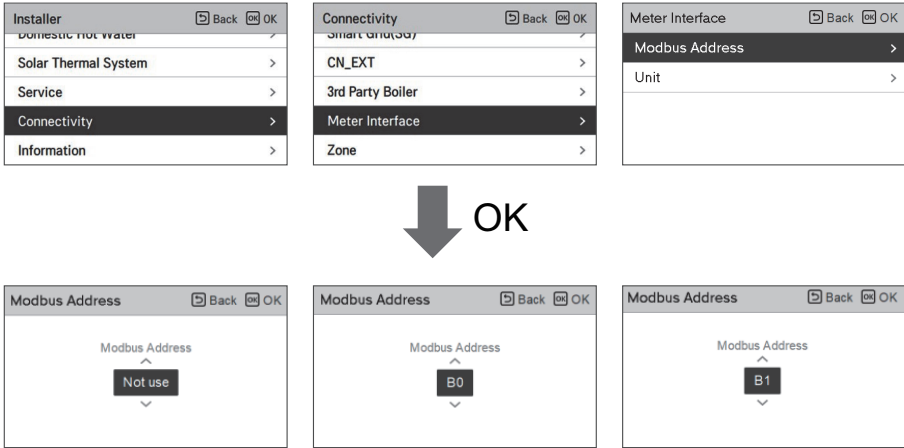

There are 2 options, modbus address and unit, in this function. Activating the modbus address option, you choose one address(B0 or B1) or don't use. Then, you set the port and specification in range of 0000.0~9999.9[pulse/kW] as shown in the figure below.

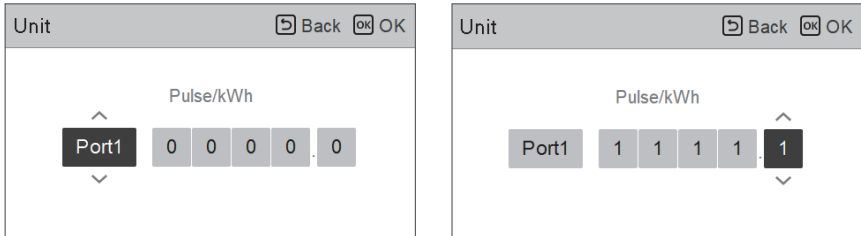

Energy state (For Hydrosplit IWT)

This function is to control the product according to the energy state. When the charged state of ESS is transmitted, it changes the target temperature of heating, cooling and DHW by setting value according to energy state.

Select either Signal Mode or Modbus Mode according to the connection type between the product and the ESS.

Select ThinQ Mode for wireless connection between the product and the ESS via ThinQ. This function is available only in Germany.

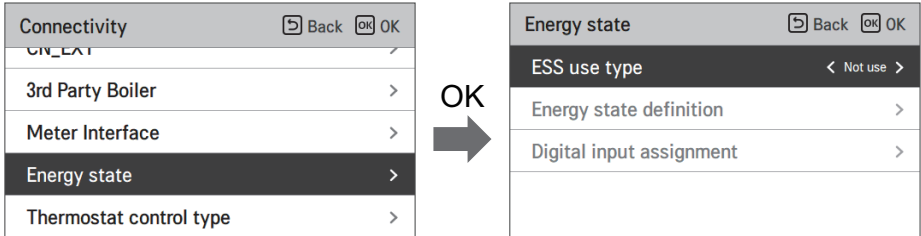

Value	Default
Not Use	Not use
Use Modbus	
Use Digital Input	
ThinQ	

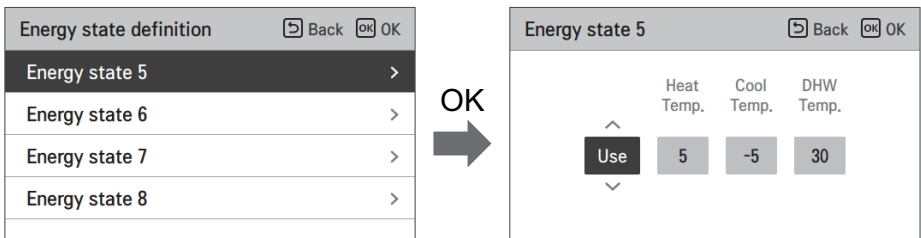

When Signal Mode of EES use type is selected, press the Digital Input Assignment button to set the energy state according to the input signal.

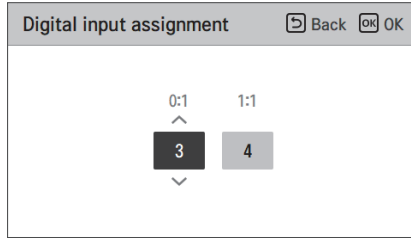

Value	Input Signal		Output state	
	ES1	ES2	Default	Range
X	0	0	ES2	fixed
X	1	0	ES1	fixed
0:1	0	1	ES3	ES3-ES8
1:1	1	1	ES4	

Thermostat control type (For Hydrosplit IWT)

It is a function to enable installer to control Water Pump Options using water flow sensor.

- In the Installer setting list, and select Connectivity category, and press [OK] button to move to the detail screen.

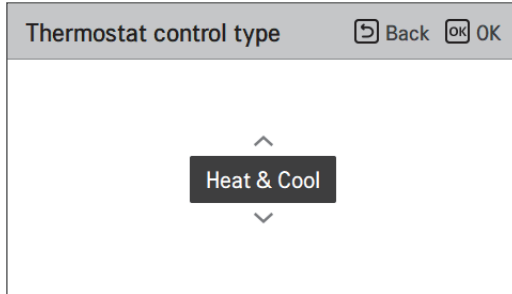
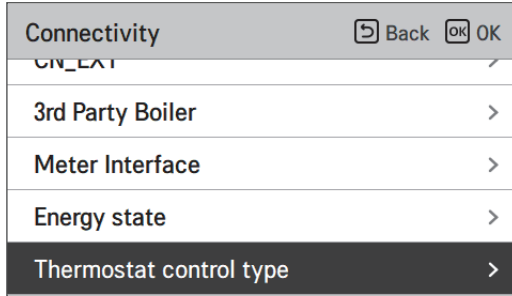

Type	
Heat & Cool (Default)	Heat & Cool / DHW

Pump operation time

It is a function to show the main water pump's operation time for check mechanical life.

- In the Installer setting list, and select Information category, and press [OK] button to move to the detail screen.

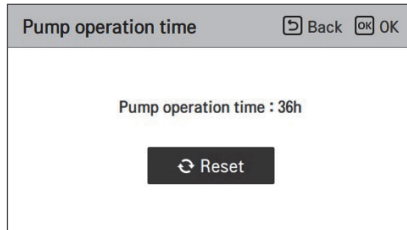
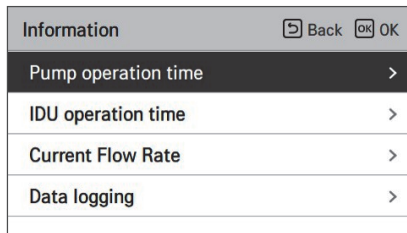
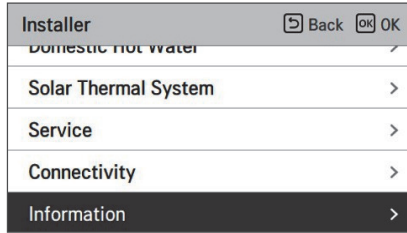

IDU operation time

It is a function to show the Indoor Unit's operation time for check mechanical life.

- In the Installer setting list, and select Information category, and press [OK] button to move to the detail screen.

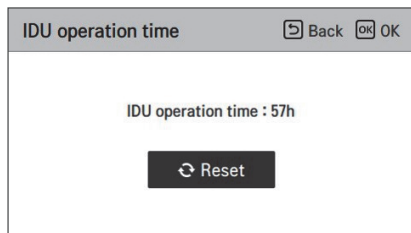
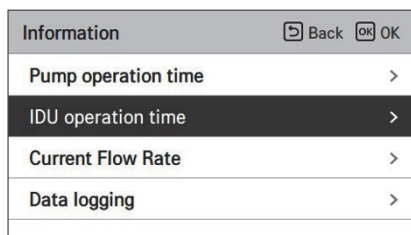
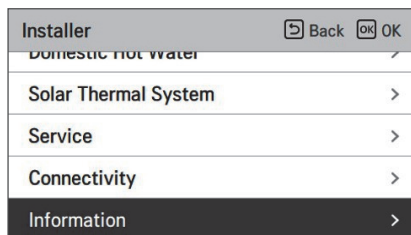

Current flow rate

It is the function to check the current flow rate.

- In the installer setting list, select Current Flow Rate category, and press [OK] button to move to the detail screen. The current flow rate can be checked. (Range : 7 ~ 80 L/min)
- The function is not available for some products.

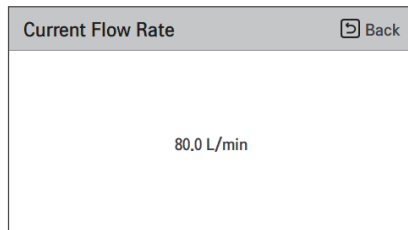
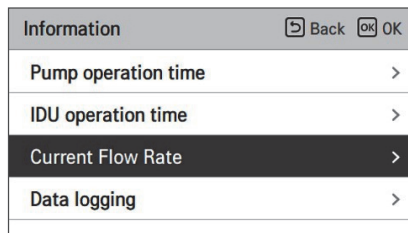
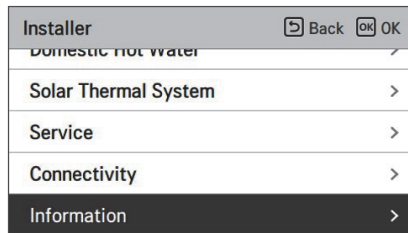

Data logging

This function is to check the operation and error history.

- In the installer setting list, select Data logging category, and press [OK] button to move to the detail screen.

Installer		Back	OK
Domestic Hot Water	>		
Solar Thermal System	>		
Service	>		
Connectivity	>		
Information	>		



Information		Back	OK
Pump operation time	>		
IDU operation time	>		
Current Flow Rate	>		
Data logging	>		



Data logging					Back
Date	Time	Oper.	Settemp	In/Out	
1970.01.01	00:10	Off	-	24° / 25°	
1970.01.01	00:09	Off	-	24° / 25°	
1970.01.01	00:09	Off	-	24° / 25°	>
1970.01.01	00:09	Off	-	24° / 25°	
1970.01.01	00:09	Off	-	24° / 25°	

NOTE

Error history lookup range: 50

Error history information

Item: date, time, mode (including Off), set temperature, incoming temperature, outgoing temperature, room temperature, Hot water operation / stop, Hot water set temperature, Hot water temperature, Outdoor unit On / Off, Error code

Number of Display: Within 50

- Save criteria ▾

▾ Error occurred, released ON / OFF of outdoor unit operation.

COMMISSIONING

If everything is going well until now, it is time to start the operation and to take advantages of **THERMAV**.

Before starting operation, pre-check points are described in this chapter. Some comments about maintenance and how to do troubleshooting are presented.

Check List before Starting Operation



CAUTION

Turn off the power before changing wiring or handling product.

No	Category	Item	Check Point
1	Electricity	Field wiring	<ul style="list-style-type: none"> All switches having contacts for different poles should be wired tightly according to regional or national legislation. Only qualified person can proceed wiring. Wiring and local-supplied electric parts should be complied with European and regional regulations. Wiring should be following the wiring diagram supplied with the product.
2		Protective devices	<ul style="list-style-type: none"> Install ELB (earth leakage breaker) with 30 mA. ELB inside the control box of the unit should be turned on before starting operation.
3		Earth wiring	<ul style="list-style-type: none"> Earth should be connected. Do not earth to gas or city water pipe, metallic section of a building, surge absorber, etc.
4		Power supply	<ul style="list-style-type: none"> Use dedicated power line.
5		Terminal block wiring	<ul style="list-style-type: none"> Connections on the terminal block (inside the control box of the unit) should be tightened.
6	Water	Charged water pressure	<ul style="list-style-type: none"> After water charging, the pressure gauge (in front of the unit) should indicate 2.0~2.5 bar. Do not exceed 3.0 bar.
7		Air purge	<ul style="list-style-type: none"> During water charging, air should be taken out through the hole of the air purge. If water does not splash out when the tip (at the top of the hole) is pressed, then air purging is not completed yet. If well purged, the water will splash out like fountain. Be careful when testing air purge. Splashed water may make your dress wet.
8		Shut-off valve	<ul style="list-style-type: none"> Two shut-off valves (located at the end of water inlet pipe and water outlet pipe of the unit) should be open.
9		By-pass valve	<ul style="list-style-type: none"> By-pass valve should be installed and adjusted to secure enough water flow rate. If water flow rate is low, flow switch error (CH14) can be occurred.
10	Product Installation	Hang to the wall	<ul style="list-style-type: none"> As the unit is hung on the wall, vibration or noise can be heard if the unit is not fixed tightly. If the unit is not fixed tightly, it can fall down during operation.
11		Parts inspection	<ul style="list-style-type: none"> There should be no apparently damaged parts inside the unit.
12		Refrigerant leakage	<ul style="list-style-type: none"> Refrigerant leakage degrades the performance. If leakage found, contact qualified LG air conditioning installation person.
13		Drainage treatment	<ul style="list-style-type: none"> While cooling operation, condensed dew can drop down to the bottom of the unit. In this case, prepare drainage treatment (for example, vessel to contain condensed dew) to avoid water drop.

To assure best performance of **THERMAV**, it is required to perform periodical check and maintenance. It is recommended to proceed following check list for once a year.



CAUTION

Turn off the power before proceeding maintenance.

No	Category	Item	Check Point
1	Water	Water pressure	<ul style="list-style-type: none"> • In normal state, the pressure gauge (in front of the unit) should indicate 2.0~2.5 bar. • If the pressure is less than 0.3 bar, please recharge the water.
2		Strainer (Water filter)	<ul style="list-style-type: none"> • Close the shut-off valves and disassemble strainer. Then wash the strainer to make it clean. • While disassembling the strainer, be careful for water flood out.
3		Safety valve	<ul style="list-style-type: none"> • Open the switch of the safety valve and check if water is flood out through the drain hose. • After checking, close the safety valve.
4	Electricity	Terminal block wiring	<ul style="list-style-type: none"> • Look and inspect if there is loosen or defected connection on the terminal block.

Starting Operation

Check before Starting Operation

1	Check to see whether there is any refrigerant leakage, and check whether the power or transmission cable is connected properly.
2	<p>Confirm that 500 V megger shows 2.0 MΩ or more between power supply terminal block and ground. Do not operate in the case of 2.0 MΩ or less.</p> <p>NOTE: Never carry out mega ohm check over terminal control board. Otherwise the control board may break.</p> <p>Immediately after mounting the unit or after leaving it turned off for an extended length of time, the resistance of the insulation between the power supply terminal board and the ground may decrease to approx. 2.0 MΩ as a result of refrigerant accumulation in the internal compressor.</p> <p>If the insulation resistance is less than 2.0 MΩ, turn on the main power supply.</p>
3	When the power is applied for the first time, operate the product after preheating for 2 hours. To protect the unit by increasing the oil temperature of the compressor.

Starting Operation flow chart

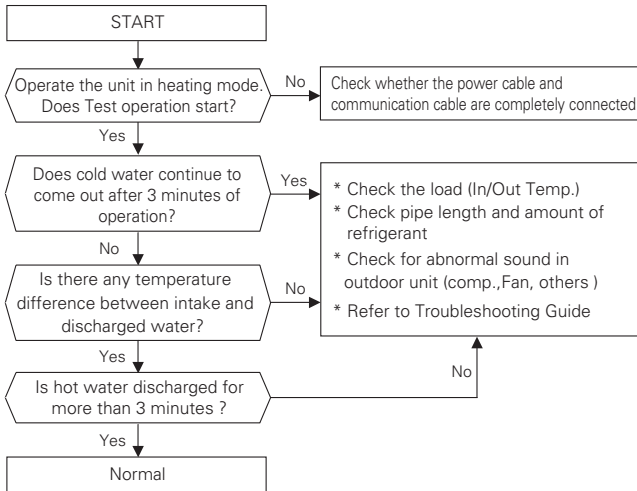

Airborne Noise Emission

The A-weighted sound pressure emitted by this product is below 70 dB.

** The noise level can vary depending on the site.

The figures quoted are emission level and are not necessarily safe working levels.

Whilst there is a correlation between the emission and exposure levels, this cannot be used reliably to determine whether or not further precautions are required.

Factor that influence the actual level of exposure of the workforce include the characteristics of the work room and the other sources of noise, i.e. the number of equipment and other adjacent processes and the length of time for which an operator exposed to the noise.

Also, the permissible exposure level can vary from country to country.

This information, however, will enable the user of the equipment to make a better evaluation of the hazard and risk.

Vacuum & Charge of Refrigerant

By default, the product was charged of refrigerant.
Vacuum and refrigerant charge, If there is leak refrigerant.

1. Vacuum

To work of vacuum action. when the leak of refrigerant.

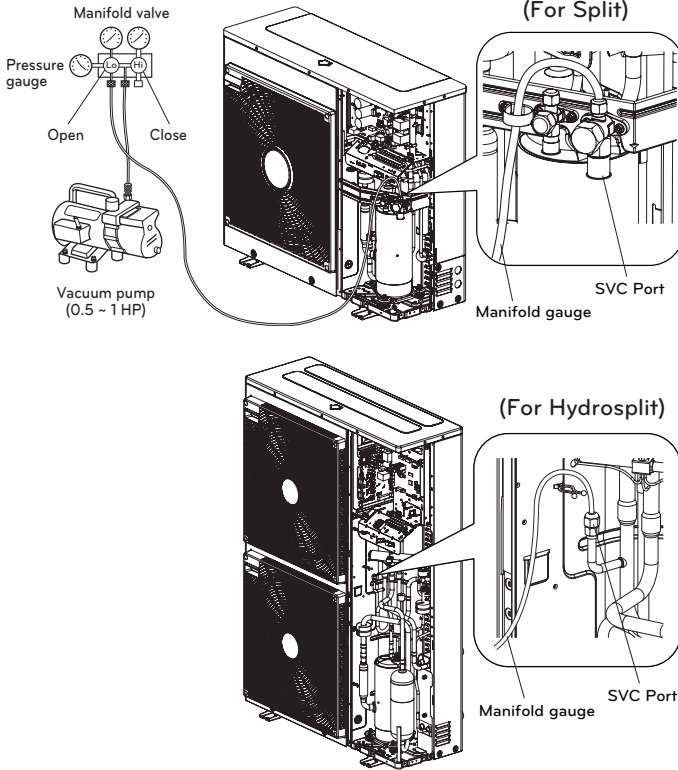

When selecting a vacuum, you should select one which is capable of achieving 0.2 Torr of ultimate vacuum.

Degree of vacuum is expressed in Torr, micron, mmHg, and Pascal (Pa). The units correlate as follows:

	Unit	Standard atmospheric pressure	Perfect vacuum
Gauge Pressure	Pa	0	-1.033
Absolute Pressure	Pa	1.033	0
Torr	Torr	760	0
Micron	Micron	760 000	0
mmHg	mmHg	0	760
Pa	Pa	1 013.33	0

2. Charge of refrigerant

You should be charged after vacuum.
 You can see amount of refrigerant at quality label.
 Please to charge at cooling mode when there is not full charging.

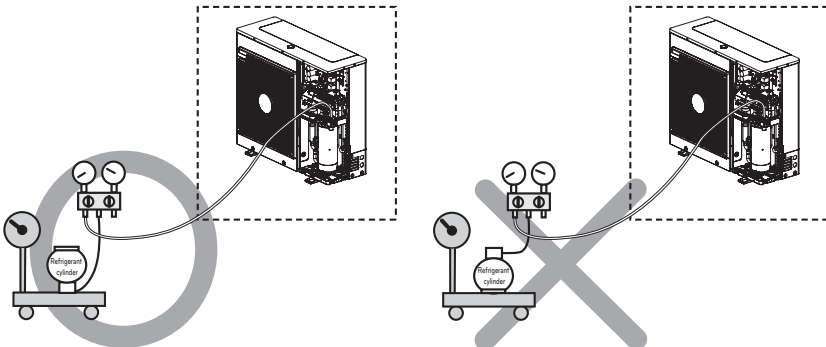
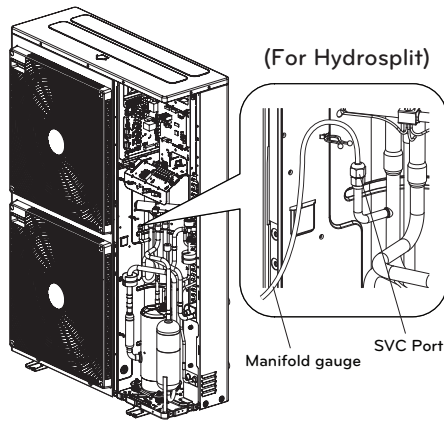
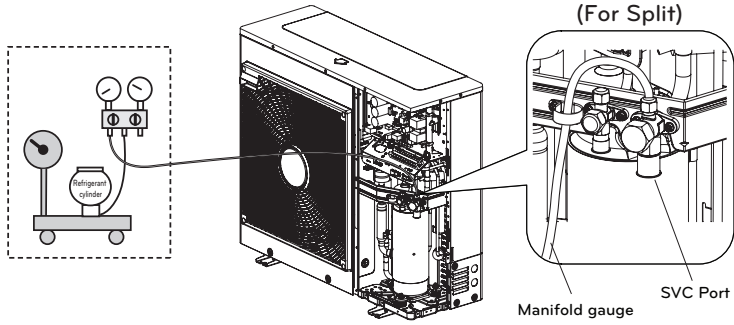

3. Location of SVC port

(For Split)

1Ø : 5 kW, 7 kW, 9 kW

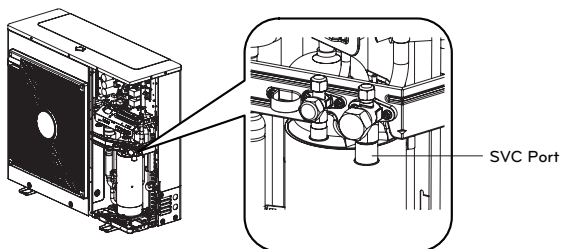

(For Hydrosplit)

1Ø : 12 kW, 14 kW, 16 kW

3Ø : 12 kW, 14 kW, 16 kW

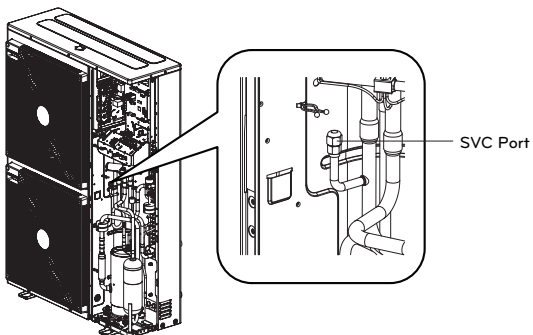

Decommissioning and Recycling

- Sort the packaging according to cardboard, wood and foil and dispose of it in appropriate containers.
- After the lifespan of the device ends it has to be disposed of in accordance with the legislation on waste electrical and electronic devices in force.

1. Extraction of Refrigerant

The indoor unit has to be connected to the outdoor unit holding the HFC refrigerant R32 which is a fluorinated greenhouse gas covered in the Kyoto protocol. You have to prevent leakage of the gas into the atmosphere. During a maintenance procedure or removal of the device, make sure that the gas is removed in accordance with the current regulations for the use of substances harmful to the ozone and fluorinated greenhouse gases.

2. Draining the unit (Heating system)

Use the drain valve below to drain the Heating system.

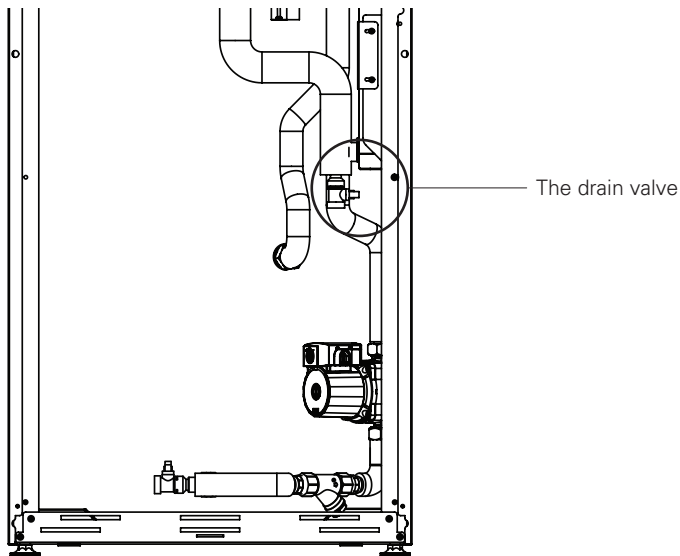

! CAUTION

Turn off the power supply of the heat pump before draining the unit.

- Turn off the unit
- Connect a hose to the drain cock and lead it into a sink.
- Open the air vent(s) at the highest level of the heating system
- Open the drain valve

3. Draining the DHW tank

Use the drain valve shown below to drain the Domestic hot water tank and circuit.

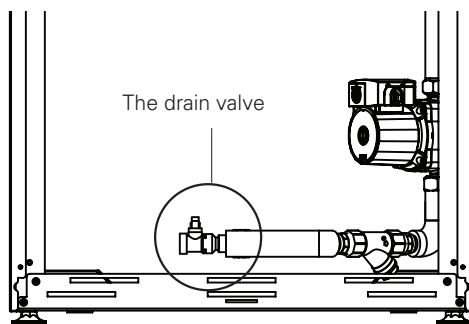

⚠ CAUTION

Turn off the power supply of the heat pump before draining the unit.

- Turn off the unit
- Close the Cold water supply line
- Connect a hose to the drain cock and lead it into a sink
- Open the drain valve
- Open the tap at the highest level of the DHW system
- If necessary, dismantle the DHW plate-heat-exchanger and push out the water by using air pressure

Replacing magnesium anode

The DHW tank is coated on the inside with special direct enamel and is equipped with a magnesium anode that protects the tank interior from corrosion.

The magnesium anode should be checked on a regular basis, at least every two year after commissioning and be replaced if necessary.

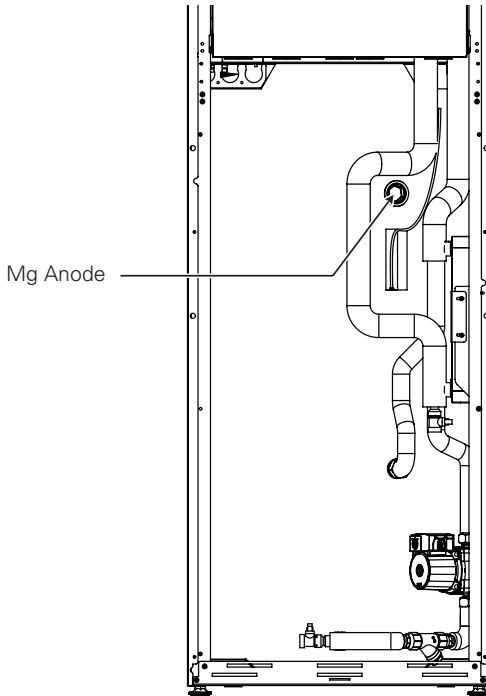

CAUTION

Before checking the anode, drain the DHW tank.

Troubleshooting

If **THERMAV** operates not properly or it does not start operation, please check following list.



CAUTION

Turn off the power before proceeding troubleshooting.

Troubleshooting for Problem while Operation

No	Problem	Reason	Solution
1	Heating or Cooling is not satisfactory.	<ul style="list-style-type: none"> Setting target temperature is not proper. 	<ul style="list-style-type: none"> Set target temperature correctly. Check if temperature is water-based or air-based. See 'Remote sensor active' and 'Temp. sensor selection' in Chapter6.
		<ul style="list-style-type: none"> Charged water is not enough. 	<ul style="list-style-type: none"> Check pressure gauge and charge more water until pressure gauge is indication 2~2.5 Bar
		<ul style="list-style-type: none"> Water flow rate is low. 	<ul style="list-style-type: none"> Check if strainer gathers too much particles. If so, strainer should be cleaned. Check if pressure gauge indicates above 4 Bar Check if water pipe is getting closed due to stacked particles or lime.
2	Although electric power supply is OK (remote controller displays information), the unit does not start working.	<ul style="list-style-type: none"> Water inlet temperature is too high. 	<ul style="list-style-type: none"> If water inlet temperature is above 57 °C, the unit does not operated for the sake of system protection
		<ul style="list-style-type: none"> Water inlet temperature is too low. 	<ul style="list-style-type: none"> If water inlet temperature is below 5 °C in cooling operation, the unit does not operated for the sake of system protection. Wait while unit warms up the water inlet temperature. If water inlet temperature is below 15 °C in heating operation, the unit does not operated for the sake of system protection. Wait while unit warms up to 18 °C the water inlet temperature. If you are not using the back up heater accessory (HA**1M E1), increase the water temperature with the external heat source (heater, boiler). If the problem persists, contact your dealer. If you want to use the screed drying function, be sure to purchase and install back up hater accessories (HA**1M E1).
3	Water pump noise.	<ul style="list-style-type: none"> Air purging is not completely finished. 	<ul style="list-style-type: none"> Open the cap of air purge and charge more water until pressure gauge is indicating 2~2.5 Bar If water does not splash out when the tip(at the top of the hole) is pressed, then air purging is not completed yet. If well purged, the water will splash out like fountain.
		<ul style="list-style-type: none"> Water pressure is low. 	<ul style="list-style-type: none"> Check if pressure gauge indicates above 0.3 Bar. Check if the expansion tank and pressure gauge operates well.
4	Water is flood out through drain hose.	<ul style="list-style-type: none"> Too much water is charged. 	<ul style="list-style-type: none"> Flood out water by opening the switch of the safety valve until pressure gauge is indicating 2~2.5 Bar.
		<ul style="list-style-type: none"> Expansion tank is damaged. 	<ul style="list-style-type: none"> Replace the expansion tank
5	DHW is not hot.	<ul style="list-style-type: none"> Thermal protector of water tank heater is activated. 	<ul style="list-style-type: none"> Open the side panel of the DHW tank and push the reset button of the thermal protector. (for more detail information, please refer to installation manual of DHW tank.
		<ul style="list-style-type: none"> DHW Heating is disabled. 	<ul style="list-style-type: none"> Select DHW Heating Operation and identify if icon is displayed on the remote controller.

Troubleshooting for Error Code

Display code	Title	Cause of error	Check point & Normal condition
1	Problem in remote room air sensor	<ul style="list-style-type: none"> • Incorrect connection between sensor and PCB(Heater). • PCB(Heater) fault • Sensor fault 	<ul style="list-style-type: none"> • Resistance: 10 kΩ at 25 centigrade (unplugged) → for Remote room air sensor • Resistance: 5 kΩ at 25 centigrade (unplugged) → for all sensors EXCEPT remote room air sensor • Voltage: 2.5 V DC at 25 centigrade (plugged) (for all sensors) • Refer resistance-temperature table to check in different temperature
2	Problem in refrigerant (inlet side) sensor		
6	Problem in refrigerant (outlet side) sensor		
8	Problem in water tank sensor		
16	Problems in sensors		
17	Problem in water-inlet sensor		
18	Problem in water-outlet sensor		
19	Problem in Electric heater outlet sensor		
10	Water pump Lock	Fault feedback signal detected From Indoor water pump (for 30 seconds)	<ul style="list-style-type: none"> • Water pump defect • If there is a leak in the water pipe system • Wiring defect • Main PCB(Indoor)/Harness defect
3	Bad communication between remote controller and unit.	<ul style="list-style-type: none"> • Incorrect connection between sensor and PCB(Heater) • PCB(Heater) fault • Sensor fault 	<ul style="list-style-type: none"> • Wire connection between remote controller and Main PCB assembly(Heater) should be tight • Output voltage of PCB should be 12 V DC
5	Bad communication between Main PCB assembly(Heater) and Main PCB assembly(Inverter) of the unit.	<ul style="list-style-type: none"> • The connector for transmission is disconnected • The connecting wires are misconnected • The communication line is broken • Main PCB assembly(Inverter) is abnormal • Main PCB assembly(Heater) is abnormal 	<ul style="list-style-type: none"> • Wire connection between remote control panel and Main PCB assembly(Heater) should be tight.
53			
9	PCB program (EEPROM) fault	<ul style="list-style-type: none"> • Electrical or mechanical damage a the EEPROM 	<ul style="list-style-type: none"> • This error can not be permitted
14	Problem in flow sensor	Flow sensor <ul style="list-style-type: none"> • Water Pump ON. : If flow rate is not more than 7 LPM or not less than 80 LPM, detect it for 15 seconds. • Water Pump OFF. : If flow rate is not less than 7 LPM, detect it for 15 seconds. 	Flow Sensor <ul style="list-style-type: none"> • Display the flow rate value that received from the indoor unit. (Range : 7 ~ 80 L/min)

Display code	Title	Cause of error	Check point & Normal condition
15	Water pipe overheated	<ul style="list-style-type: none"> Abnormal operation of electric heater Leaving water temperature is above 57 °C(R410A)/65 °C(R32) 	<ul style="list-style-type: none"> If there is no problem in electric heater control, possible maximum leaving water temperature is 57 °C (R410A)/65 °C(R32)
20	Thermal fuse is damaged	<ul style="list-style-type: none"> Thermal fuse is cut off by abnormal overheating of internal electric heater Mechanical fault at thermal fuse Wire is damaged 	<ul style="list-style-type: none"> This error will not be happened if temperature of electric heater tank is below 80 °C
21	DC PEAK (IPM Fault)	<ul style="list-style-type: none"> Instant over current Over Rated current Poor insulation of IPM 	<ul style="list-style-type: none"> An instant over current in the U,V,W phase <ul style="list-style-type: none"> - Comp lock - The abnormal connection of U,V,W Over load condition <ul style="list-style-type: none"> - Overcharging of refrigerant Pipe length. Outdoor Fan is stop Poor insulation of compressor
22	Max. C/T	Input Over Current	<ul style="list-style-type: none"> Malfunction of Compressor Blocking of Pipe Low Voltage Input Refrigerant, Pipe length, Blocked...
23	DC Link High / Low Volt	<ul style="list-style-type: none"> DC Link Voltage is above 420 V DC DC Link Voltage is below 140 V DC 	<ul style="list-style-type: none"> Check CN_(L), CN_(N) Connection Check Input Voltage Check PCB DC Link voltage sensor parts
24	High pressure Error (Activation of pressure switch)	Compressor stop by operating high pressure switch	<ul style="list-style-type: none"> High pressure switch failure Fan failure of outdoor unit Compressor check valve clogged Deformation due to breakage of refrigerant pipe Refrigerant overcharge Poor outdoor EEV Shielding (Indoor filter clogged during heating) Bad outdoor unit board
26	DC Compressor Position	<ul style="list-style-type: none"> Compressor Starting fail error 	<ul style="list-style-type: none"> Check the connection of comp wire "U,V,W" Malfunction of compressor Check the component of "IPM", detection parts.
27	AC Input Instant over Current Error	PCB(Inverter) input current is over 100 A(peak) for 2 us	<ul style="list-style-type: none"> Overload operation (Pipe clogging/Covering/EEV defect/Ref. overcharge) Compressor damage (Insulation damage/Motor damage) Input voltage abnormal (L,N) Power line assemble condition abnormal PCB assembly 1 Damage (input current sensing part)
29	Inverter compressor over current	(HM**1M U*3) Inverter Compressor input current is 30 A. (HM**3M U*3) Inverter Compressor input current is 24 A.	<ul style="list-style-type: none"> Overload operation (Pipe clogging/Covering/EEV defect/Ref. overcharge) Compressor damage(Insulation damage/Motor damage) Input voltage low ODU PCB assembly 1 damage

Display code	Title	Cause of error	Check point & Normal condition
32	High temperature in Discharge pipe of the inverter compressor	<ul style="list-style-type: none"> • Overload operation (Outdoor fan constraint, screened, blocked) • Refrigerant leakage (insufficient) • Poor INV Comp Discharge sensor • LEV connector displaced / poor LEV assembly 	<ul style="list-style-type: none"> • Check outdoor fan constraint/ screened/ flow structure • Check refrigerant leakage • Check if the sensor is normal • Check the status of EEV assembly
35	Low Presser Error	Excessive decrease of low pressure	<ul style="list-style-type: none"> • Defective low pressure sensor • Defective unit fan • Refrigerant shortage/leakage • Deformation because of damage of refrigerant pipe • Defective unit EEV • Covering / clogging (unit covering during the cooling mode / unit filter clogging during heating mode) • SVC valve clogging • Defective unit PCB(Inverter) • Defective unit pipe sensor
41	Problem in D-pipe temperature sensor	<ul style="list-style-type: none"> • Open / Short • Soldered poorly • Internal circuit error 	<ul style="list-style-type: none"> • Bad connection of thermistor connector • Defect of thermistor connector (Open/Short) • Defect of outdoor PCB(Inverter)
43	Problem in high pressure sensor	Abnormal value of sensor (Open/Short)	<ul style="list-style-type: none"> • Bad connection of connector PCB(Inverter) • Bad connection high pressure connector • Defect of high pressure connector (Open/Short) • Defect of connector PCB(Inverter) (Open/Short) • Defect of PCB(Inverter)
44	Problem in outdoor air temperature sensor	<ul style="list-style-type: none"> • Open / Short • Soldered poorly • Internal circuit error 	<ul style="list-style-type: none"> • Bad connection of thermistor connector • Defect of thermistor connector (Open/Short) • Defect of outdoor PCB(Inverter)
45	Problem in Cond. middle pipe temperature sensor		
46	Problem in suction pipe temperature sensor		
48	Condenser out pipe temperature Error		
52	PCB Communication Error	Checking the communication state between Main PCB and Inverter PCB	<ul style="list-style-type: none"> • Generation of noise source interfering with communication
54	Open and Reverse Phase Error	Prevention of phase unbalance and prevention of reverse rotation of constant-rate compressor	Main power wiring fault

Display code	Title	Cause of error	Check point & Normal condition
60	PCB(Inverter) & Main EEPROM check sum error	EEPROM Access error and Check SUM error	<ul style="list-style-type: none"> • EEPROM contact defect/wrong insertion • Different EEPROM Version • ODU Inverter & Main PCB assembly 1 damage
61	High temperature in Cond. Pipe	<ul style="list-style-type: none"> • Overload operation (Outdoor fan constraint, screened, blocked) • Unit heat exchanger contaminated • EEV connector displaced / poor EEV assembly • Poor Cond. Pipe sensor assembly / burned 	<ul style="list-style-type: none"> • Check outdoor fan constraint / screened / flow structure • Check if refrigerant overcharged • Check the status of EEV assembly • Check the status of sensor assembly / burn
62	Heat sink Temp, High error	Heat sink sensor detected high temp.(85 °C)	<ul style="list-style-type: none"> • Part no. : EBR37798101~09 <ul style="list-style-type: none"> - Check the Heat sink sensor: 10 kΩ / at 25 °C Unplugged) - Check the outdoor fan is driving rightly • Part no. : EBR37798112~21 <ul style="list-style-type: none"> - Check the soldered condition in the 22,23 pin of IPM, PFCM - Check the screw torque of IPM, PFCM - Check the spreadable condition of thermal grease on IPM, PFCM - Check the outdoor fan is driving rightly
65	Problem in Heat sink Temperature sensor	Abnormal value of sensor(Open/Short)	<ul style="list-style-type: none"> • Check if there is defect of thermistor connector (Open/Short) • Check defect of outdoor PCB(Inverter)
67	Fan lock error	Fan RPM is less than 10 for 5 seconds from start-up operation. Fan RPM is less than 40 in operation except for start-up operation	<ul style="list-style-type: none"> • Fan motor damage. • Assembly condition abnormal. • Jammed fan by surroundings.
114	Problem in Vapor injection inlet temperature sensor	<ul style="list-style-type: none"> • Open / short of outdoor unit sensor • Soldered poorly • Internal circuit error 	<ul style="list-style-type: none"> • Bad connection of thermistor connector • Defect of thermistor connector (Open/Short) • Defect of outdoor PCB(Outdoor)
115	Problem in Vapor injection outlet temperature sensor		
231	Problem in Water pressure sensor	Water Pressure Sensor of indoor unit is damaged.	<ul style="list-style-type: none"> • Sensor mismatch on the main PCB of Indoor unit. • The main PCB of Indoor unit.
232	Problem in Flow sensor	Flow Sensor of indoor unit is damaged.	<ul style="list-style-type: none"> • Sensor failure (Reason of major defect)

Reset of the thermal protection of the electrical heater

The thermal protection of the electrical heater is an additional safeguard protecting the device in the following cases:

- The electrical relay, which turns on the electrical flow heater can be permanently short-circuited.
- At commissioning, air is in the system; this causes heating without heat extraction.

The easiest way to determine whether the thermal protection of the electrical heater is operative is to force the Backup heater to work using the Emergency mode (refer to the Owner's manual for more detail).

Determine if you can feel by hand the difference between the supply line and the return line. The electrical heater works if the supply line is warmer.

In case the electrical heater does not work because of one of the aforementioned reasons, the Safety thermostat has to be reset manually after the problem is resolved.

First you have to remove the front panel. Reset the safety thermostat by pressing the red button until you hear a "CLICK".

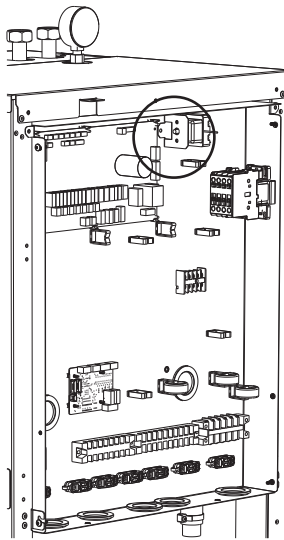

CAUTION

Resetting the device can only be performed by installers, authorized contractors for commission or authorized maintenance worker in a voltage-free state.

Open Source Software Notice Information

To obtain the source code under GPL, LGPL, MPL, and other open source code licenses, that is contained in this product, Please visit <https://opensource.lge.com>.

In addition to the source code, all referred license terms, warranty disclaimers and copyright notice are available for download. LG Electronics will also provide open source code to you on CD-ROM for a charge covering the cost of performing such distribution (such as the cost of media, shipping, and handling) upon email request to opensource@lge.com. This offer is valid for three(3) years from the date on which you purchased the product.



Eco Design requirement

The information for Eco design is available on the following free access website.

<https://www.lg.com/global/support/cedoc/cedoc>

[Representative] LG Electronics Inc. EU Representative : LG Electronics European Shared Service
Center B.V. Krijgsman 1, 1186 DM Amstelveen, The Netherlands

[Manufacturer] KRONOTERM d.o.o, Tranava 5E, 3303 Gomilsko, Brezovica, Slovenia