



INSTALLATION MANUAL

AIR CONDITIONER

Please read this installation manual completely before installing the product.
Please retain this installation manual for future reference after reading it thoroughly.

Wall Mounted / Art Cool Gallery Series
Original instruction



MFL69485413
Rev.35_112025



www.lg.com

Copyright © 2017 - 2025 LG Electronics Inc. All Rights Reserved.

РУССКИЙ ЯЗЫК

ENGLISH

УКРАЇНСЬКА

ITALIANO

ҚАЗАҚ ТІЛІ

ESPAÑOL

БЕЛАРУСКАЯ МОВА

FRANÇAIS

ЎЗБЕК ТИЛИ

DEUTSCH

ΕΛΛΗΝΙΚΑ

ČEŠTINA

NETERLANDS

POLSKI

LIMBA ROMÂNĂ

TIPS FOR SAVING ENERGY

Here are some tips that will help you minimize the power consumption when you use the air conditioner.

You can use your air conditioner more efficiently by referring to the instructions below:

- Do not cool excessively indoors. This may be harmful for your health and may consume more electricity.
- Block sunlight with blinds or curtains while you are operating the air conditioner.
- Keep doors or windows closed tightly while you are operating the air conditioner.
- Adjust the direction of the air flow vertically or horizontally to circulate indoor air.
- Speed up the fan to cool or warm indoor air quickly, in a short period of time.
- Open windows regularly for ventilation as the indoor air quality may deteriorate if the air conditioner is used for many hours.
- Clean the air filter once every 2 weeks. Dust and impurities collected in the air filter may block the air flow or weaken the cooling / dehumidifying functions.

For your records

Staple your receipt to this page in case you need it to prove the date of purchase or for warranty purposes.

Write the model number and the serial number here:

Model number : _____

Serial number : _____





You can find them on a label on the side of each unit.

Dealer's name : _____

Date of purchase : _____

SAFETY INSTRUCTIONS

The following symbols are displayed on indoor and outdoor units.

	Read the precautions in this manual carefully before operating the unit.		This appliance is filled with flammable refrigerant (for R32)
	This symbol indicates that the Operation Manual should be read carefully.		This symbol indicates that a service personnel should be handling this equipment with reference to the Installation Manual.

The following safety guidelines are intended to prevent unforeseen risks or damage from unsafe or incorrect operation of the appliance.

The guidelines are separated into 'WARNING' and 'CAUTION' as described below.

 This symbol is displayed to indicate matters and operations that can cause risk.
Read the part with this symbol carefully and follow the instructions in order to avoid risk.

WARNING

This indicates that the failure to follow the instructions can cause serious injury or death.

CAUTION

This indicates that the failure to follow the instructions can cause the minor injury or damage to the product.

WARNING

Installation

- Compliance with national gas regulations shall be observed.
- Do not use a defective or underrated circuit breaker. Use this appliance on a dedicated circuit.
 - There is risk of fire or electric shock.

- For electrical work, contact the dealer, seller, a qualified electrician, or an Authorized Service Center.
 - Do not disassemble or repair the product. There is risk of fire or electric shock.
- Always ground the product.
 - There is risk of fire or electric shock.
- Install the panel and the cover of control box securely.
 - There is risk of fire or electric shock.
- Always install a dedicated circuit and breaker.
 - Improper wiring or installation may cause fire or electric shock.
- Use the correctly rated breaker or fuse.
 - There is risk of fire or electric shock.
- Do not modify or extend the power cable.
 - There is risk of fire or electric shock.
- Do not install, remove, or re-install the unit by yourself (customer).
 - There is risk of fire, electric shock, explosion, or injury.
- Be cautious when unpacking and installing the product.
 - Sharp edges could cause injury. Be especially careful of the case edges and the fins on the condenser and evaporator.
- For installation, always contact the dealer or an Authorized Service Center.
 - There is risk of fire, electric shock, explosion, or injury.
- Do not install the product on a defective installation stand.
 - It may cause injury, accident, or damage to the product.
- Be sure the installation area does not deteriorate with age.
 - If the base collapses, the air conditioner could fall with it, causing property damage, product failure, and personal injury.

- Do not turn on the breaker or power under condition that front panel, cabinet, top cover, control box cover are removed or opened.
 - Otherwise, it may cause fire, electric shock, explosion or death.
- Use a vacuum pump or Inert (nitrogen) gas when doing leakage test or air purge. Do not compress air or Oxygen and Do not use Flammable gases. Otherwise, it may cause fire or explosion.
 - There is the risk of death, injury, fire or explosion.
- Have all electric work done by a licensed electrician according to "Electric Facility Engineering Standard" and "Interior Wire Regulations" and the instructions given in this manual and always use a special circuit.
 - If the power source capacity is inadequate or electric work is performed improperly, electric shock or fire may result.
- Always install a dedicated circuit and breaker.
 - Improper wiring or installation may cause fire or electric shock.
- The appliance shall be stored in a well-ventilated area where the room size corresponds to the room area as specified for operation. (for R32)
- The appliance shall be stored in a room without continuously operating ignition sources (for example: open flames, an operating gas appliance or an operating electric heater.)
- Keep any required ventilation openings clear of obstruction.
- Mechanical connections shall be accessible for maintenance purposes.
- To prevent the mixing of different types of refrigerants, be sure to check the type of refrigerant used in the outdoor unit.
- The appliance shall be installed in accordance with the national wiring regulation.

Operation

- Do not let the air conditioner run for a long time when the humidity is very high and a door or a window is left open.
 - Moisture may condense and wet or damage furniture.
- Take care to ensure that power cable could not be pulled out or damaged during operation.
 - There is risk of fire or electric shock.
- Do not place anything on the power cable.
 - There is risk of fire or electric shock.
- Do not plug or unplug the power supply plug during operation.
 - There is risk of fire or electric shock.
- Do not touch(operate) the product with wet hands.
 - There is risk of fire or electrical shock.
- Do not place a heater or other appliances near the power cable.
 - There is risk of fire and electric shock.
- Do not allow water to run into electric parts.
 - There is risk of fire, failure of the product, or electric shock.
- Do not store or use flammable gas or combustibles near the product.
 - There is risk of fire or failure of product.
- Do not use the product in a tightly closed space for a long time.
 - Oxygen deficiency could occur.
- When flammable gas leaks, turn off the gas and open a window for ventilation before turn the product on.
 - Do not use the telephone or turn switches on or off. There is risk of explosion or fire.
- If strange sounds, smell or smoke comes from product. Turn the breaker off or disconnect the power supply cable.
 - There is risk of electric shock or fire.

- Stop operation and close the window in storm or hurricane. If possible, remove the product from the window before the hurricane arrives.
 - There is risk of property damage, failure of product, or electric shock.
- Do not open the inlet grill of the product during operation. (Do not touch the electrostatic filter, if the unit is so equipped.)
 - There is risk of physical injury, electric shock, or product failure.
- When the product is soaked (flooded or submerged), contact an Authorized Service Center.
 - There is risk of fire or electric shock.
- Be cautious that water could not enter the product.
 - There is risk of fire, electric shock, or product damage.
- Ventilate the product from time to time when operating it together with a stove, etc.
 - There is risk of fire or electric shock.
- Turn the main power off when cleaning or maintaining the product.
 - There is risk of electric shock.
- When the product is not be used for a long time, disconnect the power supply plug or turn off the breaker.
 - There is risk of product damage or failure, or unintended operation.
- Take care to ensure that nobody could step on or fall onto the outdoor unit.
 - This could result in personal injury and product damage.
- When mechanical connectors are reused indoors, sealing parts shall be renewed. (for R32)
- When flared joints are reused indoors, the flare part shall be refabricated. (for R32)

- Periodic (more than once/year) cleaning of the dust or salt particles stuck on the heat exchanger by using water.
- Do not use means to accelerate the defrosting process or to clean, other than those recommended by the manufacturer.
- Do not pierce or burn refrigerant cycle part.
- Be aware that refrigerants may not contain an odour.

CAUTION

Installation

- Always check for gas (refrigerant) leakage after installation or repair of product.
 - Low refrigerant levels may cause failure of product.
- Install the drain hose to ensure that water is drained away properly.
 - A bad connection may cause water leakage.
- Keep level even when installing the product.
 - To avoid vibration or water leakage.
- Do not install the product where the noise or hot air from the outdoor unit could damage the neighborhoods.
 - It may cause a problem for your neighbors.
- Use two or more people to lift and transport the product.
 - Avoid personal injury.
- Do not install the product where it will be exposed to sea wind (salt spray) directly.
 - It may cause corrosion on the product. Corrosion, particularly on the condenser and evaporator fins, could cause product malfunction or inefficient operation.

- Any person who is involved with working on or breaking into a refrigerant circuit should hold a current valid certificate from an industry-accredited assessment authority, which authorises their competence to handle refrigerants safely in accordance with an industry recognised assessment specification. (for R32)
- The appliance shall be stored so as to prevent mechanical damage from occurring.
- Refrigerant tubing shall be protected or enclosed to avoid damage.
- Flexible refrigerant connectors (such as connecting lines between the indoor and outdoor unit) that may be displaced during normal operations shall be protected against mechanical damage.
- The installation of pipe-work shall be kept to a minimum.
- Pipe-work shall be protected from physical damage.
- A brazed, welded, or mechanical connection shall be made before opening the valves to permit refrigerant to flow between the refrigerating system parts.
- Dismantling the unit, treatment of the refrigerant oil and eventual parts should be done in accordance with local and national standards.
- Do not install the unit in potentially explosive atmospheres.

Operation

- Do not expose the skin directly to cool air for long periods of time. (Don't sit in the draft.)
 - This could harm to your health.
- Do not use the product for special purposes, such as preserving foods, works of art, etc. It is a consumer air conditioner, not a precision refrigeration system.
 - There is risk of damage or loss of property.

- Do not block the inlet or outlet of air flow.
 - It may cause product failure.
- Use a soft cloth to clean. Do not use harsh detergents, solvents, etc.
 - There is risk of fire, electric shock, or damage to the plastic parts of the product.
- Do not touch the metal parts of the product when removing the air filter. They are very sharp!
 - There is risk of personal injury.
- Do not step on or put anything on the product. (outdoor units)
 - There is risk of personal injury and failure of product.
- Always insert the filter securely. Clean the filter every two weeks or more often if necessary.
 - A dirty filter reduces the efficiency of the air conditioner and could cause product malfunction or damage.
- Do not insert hands or other objects through the air inlet or outlet while the product is operated.
 - There are sharp and moving parts that could cause personal injury.
- Do not drink the water drained from the product.
 - It is not sanitary and could cause serious health issues.
- Use a firm stool or ladder when cleaning or maintaining the product.
 - Be careful and avoid personal injury.
- Replace the all batteries in the remote control with new ones of the same type. Do not mix old and new batteries or different types of batteries.
 - There is risk of fire or explosion.
- Do not recharge or disassemble the batteries. Do not dispose of batteries in a fire.
 - They may burn or explode.

- If the liquid from the batteries gets onto your skin or clothes, wash it well with clean water. Do not use the remote if the batteries have leaked.
 - The chemicals in batteries could cause burns or other health hazards.
- If you eat the liquid from the batteries, brush your teeth and see doctor. Do not use the remote if the batteries have leaked.
 - The chemicals in batteries could cause burns or other health hazards.
- Servicing shall only be performed as recommended by the equipment manufacturer. Maintenance and repair requiring the assistance of other skilled personnel shall be carried out under the supervision of the person competent in the use of flammable refrigerants. (for R32)
- Means for disconnection must be incorporated in the fixed wiring in accordance with the wiring rules.
- If the supply cord is damaged, it must be replaced by the manufacturer, its service agent or similarly qualified persons in order to avoid a hazard.

TABLE OF CONTENTS

2 TIPS FOR SAVING ENERGY

3 SAFETY INSTRUCTIONS

13 INSTALLATION PARTS





13 INSTALLATION TOOLS

14 INSTALLATION MAP

15 INSTALLATION

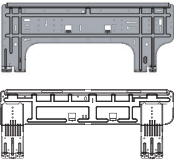
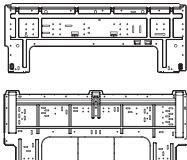
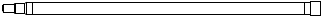







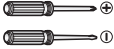

- 15 Select the best Location
- 17 Fixing Installation Plate
- 18 Drill a Hole in the Wall
- 18 Flaring Work
- 19 Connecting the Piping (SJ/SK)
- 22 Connecting the Piping (SV)
- 26 Checking the Drainage
- 27 Manual the decor, air filter Assembly & Disassembly
- 28 Installation of filters
- 28 Wiring Connection
- 30 DIP Switch Setting
- 31 Group Control Setting
- 36 Model Designation
- 36 Airborne Noise Emission
- 36 Limiting concentration

INSTALLATION PARTS

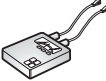
Name		Shape	
Installation plate		 <p>SJ</p>	 <p>SK SV</p>
Drain hose			
Screw	Type "A"		
	Type "C"		-
Cloth tape			-

Cloth tape is not attached to the product.

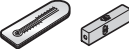
INSTALLATION TOOLS

Figure	Name	Figure	Name
	Screw driver		Multi-meter
	Electric drill		Hexagonal wrench
	Measuring tape, Knife		Ammeter
	Hole core drill		Gas-leak detector
	Spanner		Thermometer, Level
	Torque wrench		Flaring tool set

INSTALLATION MAP

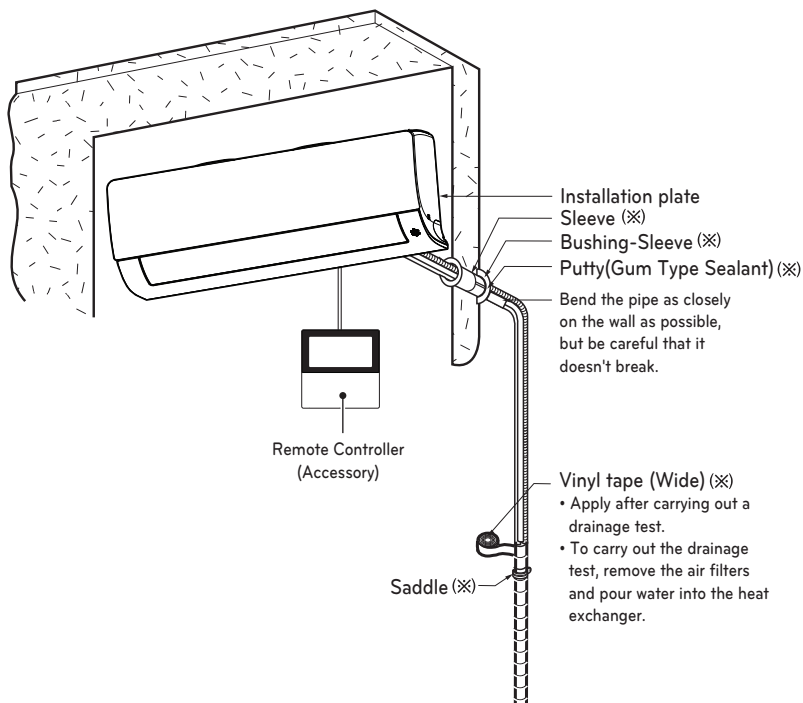

* The feature can be changed according to type of model.

NOTE

- You should purchase the installation parts.

INSTALLATION

Select the best Location

- There should not be any heat or steam near the unit.
- Select a place where there are no obstacles around of the unit.
- Make sure that condensation drainage can be conveniently routed away.
- Do not install near a doorway.
- Ensure that the interval between a wall and the left (or right) of the unit is more than 100 mm. The unit should be installed as high as possible on the wall, allowing a minimum of 200 mm from ceiling.
- Use a metal detector to locate studs to prevent unnecessary damage to the wall.

Do not use nails and/or screws to attach indoor units to sheetrock, drywall, plasterboard, tile, plywood, or similar material types without proper anchors.

Indoor units must be securely, and properly mounted and anchored or damage and/or injury may result from improper installation.

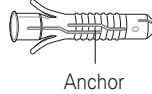

Anchor	Screw
mm	mm
6 x 30	4 x 50

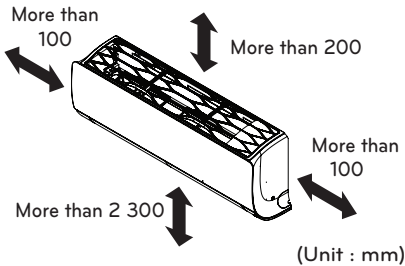

* The feature can be changed according to type of model.

CAUTION

Install the indoor unit on the wall where the height from the floor is more than 2 300 mm.

Minimum floor area (for R32)

- The appliance shall be installed, operated and stored in a room with a floor area larger than the minimum area.
- Use the graph of table to determine the minimum area.

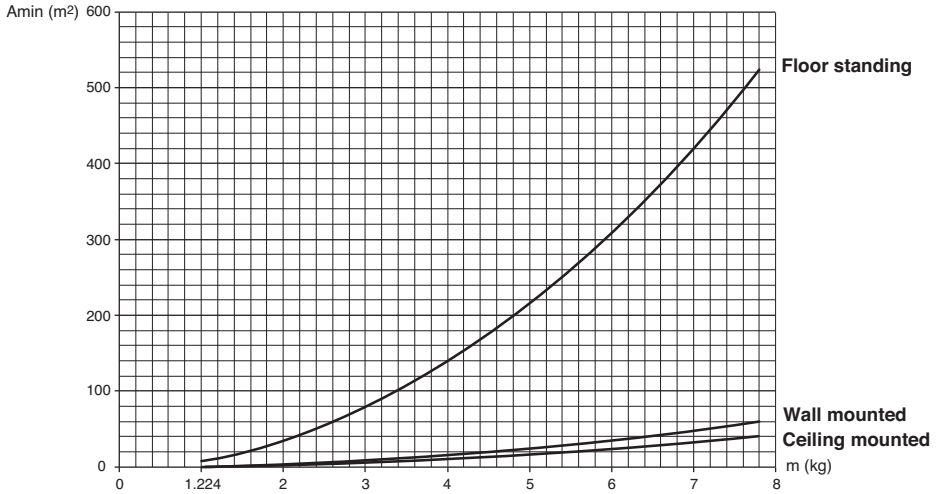

- m : Total refrigerant amount in the system
- Total refrigerant amount : factory refrigerant charge + additional refrigerant amount
- Amin : minimum area for installation

Floor location		Floor location	
m (kg)	Amin (m ²)	m (kg)	Amin (m ²)
< 1.224	-	4.6	181.56
1.224	12.9	4.8	197.70
1.4	16.82	5	214.51
1.6	21.97	5.2	232.02
1.8	27.80	5.4	250.21
2	34.32	5.6	269.09
2.2	41.53	5.8	288.65
2.4	49.42	6	308.90
2.6	58.00	6.2	329.84
2.8	67.27	6.4	351.46
3	77.22	6.6	373.77
3.2	87.86	6.8	396.76
3.4	99.19	7	420.45
3.6	111.20	7.2	444.81
3.8	123.90	7.4	469.87
4	137.29	7.6	495.61
4.2	151.36	7.8	522.04
4.4	166.12		

Wall mounted		Wall mounted	
m (kg)	Amin (m ²)	m (kg)	Amin (m ²)
< 1.224	-	4.6	20.17
1.224	1.43	4.8	21.97
1.4	1.87	5	23.83
1.6	2.44	5.2	25.78
1.8	3.09	5.4	27.80
2	3.81	5.6	29.90
2.2	4.61	5.8	32.07
2.4	5.49	6	34.32
2.6	6.44	6.2	36.65
2.8	7.47	6.4	39.05
3	8.58	6.6	41.53
3.2	9.76	6.8	44.08
3.4	11.02	7	46.72
3.6	12.36	7.2	49.42
3.8	13.77	7.4	52.21
4	15.25	7.6	55.07
4.2	16.82	7.8	58.00
4.4	18.46		

Ceiling Mounted		Ceiling Mounted	
m (kg)	Amin (m ²)	m (kg)	Amin (m ²)
< 1.224	-	4.6	13.50
1.224	0.956	4.8	14.70
1.4	1.25	5	15.96
1.6	1.63	5.2	17.26
1.8	2.07	5.4	18.61
2	2.55	5.6	20.01
2.2	3.09	5.8	21.47
2.4	3.68	6	22.98
2.6	4.31	6.2	24.53
2.8	5.00	6.4	26.14
3	5.74	6.6	27.80
3.2	6.54	6.8	29.51
3.4	7.38	7	31.27
3.6	8.27	7.2	33.09
3.8	9.22	7.4	34.95
4	10.21	7.6	36.86
4.2	11.26	7.8	38.83
4.4	12.36		

Fixing Installation Plate

The wall you select should be strong and solid enough to prevent vibration

- 1 Mount the installation plate on the wall with type "A" screws. If mounting the unit on a concrete wall, use anchor bolts.
 - Mount the installation plate horizontally by aligning the centerline using Horizontal meter.

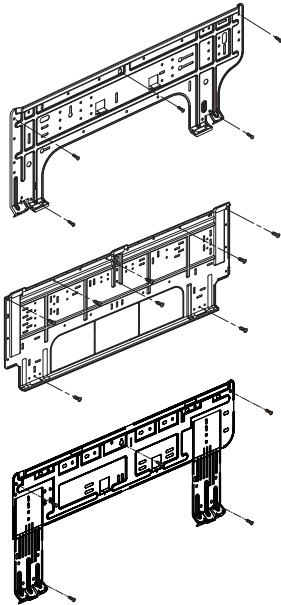

* The feature can be changed according to type of model.

- 2 Measure the wall and mark the centerline. It is also important to use caution concerning the location of the installation plate. Routing of the wiring to power outlets is through the walls typically. Drilling the hole through the wall for piping connections must be done safely.

SJ Chassis

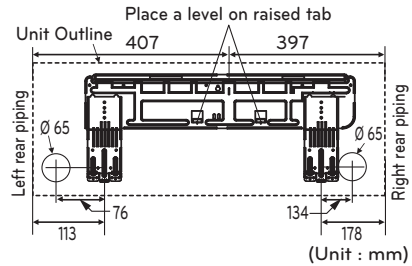
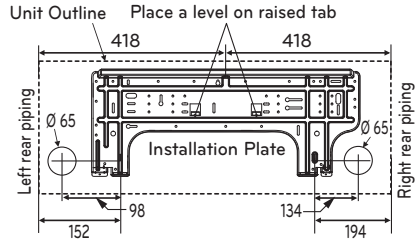

SK Chassis

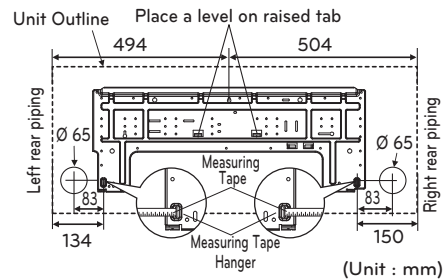

SV Chassis

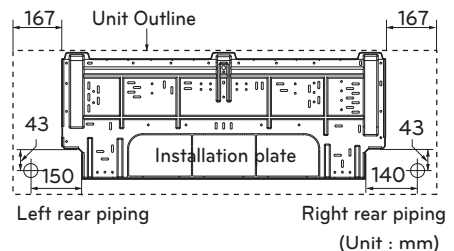

- 3 Install after removing one of the indicated cutting phase according to the installation location of the indoor unit's piping.

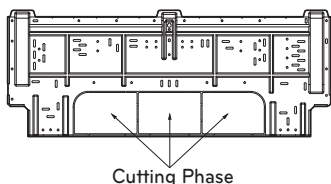

Drill a Hole in the Wall

- Drill the piping hole with a \varnothing 65 mm hole core drill. Drill the piping hole at either the right or the left with the hole slightly slanted to the outdoor side.

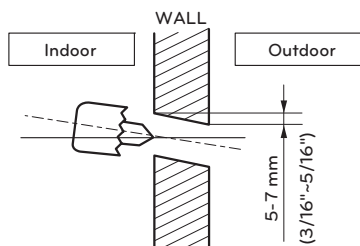

Flaring Work

Main cause for gas leakage is due to defect of flaring work. Carry out correct flaring work in the following procedure.

Cut the pipes and the cable

- 1 Use the piping kit accessory or the pipes purchased locally.
- 2 Measure the distance between the indoor and the outdoor unit.
- 3 Cut the pipes a little longer than measured distance.
- 4 Cut the cable 1.5 m longer than the pipe length.

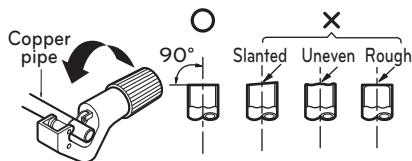

CAUTION

(for R32)

- When mechanical connectors are reused indoors, sealing parts shall be renewed.
- When flared joints are reused indoors, the flare part shall be re-fabricated.

Burrs removal

- 1 Completely remove all burrs from the cut cross section of pipe/tube.
- 2 While removing burrs put the end of the copper tube/pipe in a downward direction while removing burrs location is also changed in order to avoid dropping burrs into the tubing.

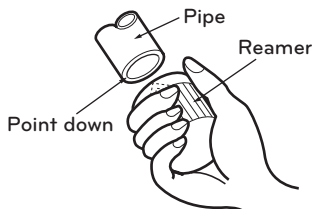

Putting nut on

- Remove flare nuts attached to indoor and outdoor unit, then put them on pipe/tube having completed burr removal. (not possible to put them on after finishing flare work)

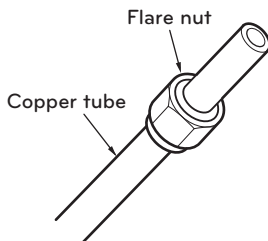

Flaring work

- 1 Firmly hold copper pipe in a bar with the dimension shown in below table table below.
- 2 Carry out flaring work with the flaring tool.

Pipe diameter inch (mm)	A inch (mm)	
	Wing nut type	Clutch type
Ø 1/4 (Ø 6.35)	0.04~0.05 (1.1~1.3)	0~0.02 (0~0.5)
Ø 3/8 (Ø 9.52)	0.06~0.07 (1.5~1.7)	
Ø 1/2 (Ø 12.7)	0.06~0.07 (1.6~1.8)	
Ø 5/8 (Ø 15.88)	0.06~0.07 (1.6~1.8)	
Ø 3/4 (Ø 19.05)	0.07~0.08 (1.9~2.1)	

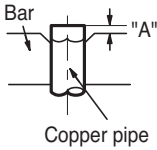

<Wing nut type>

<Clutch type>

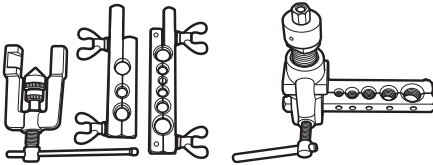

Check

- 1 Compare the flared work with the figure by.
- 2 If a flared section is defective, cut it off and do flaring work again.

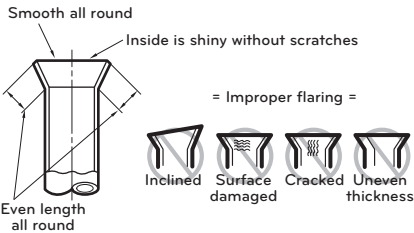

Connecting the Piping (SJ/SK)

- 1 Pull the cover at the bottom of the indoor unit. Pull the cover ① → ②.
- 2 Remove the cover from the indoor unit.

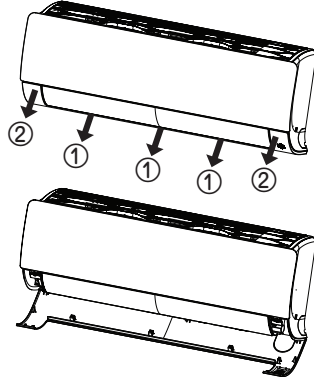

- 3 Pull back the tubing holder.
- 4 Remove pipe port cover and positioning the tubing

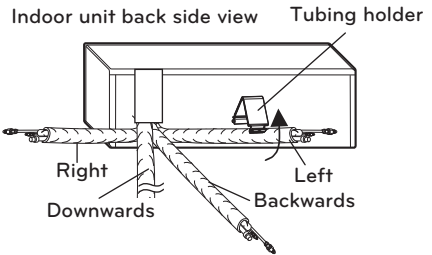

* The feature can be changed according to type of model.

Assembly of chassis cover

- 1 Insert 3 hooks of the chassis cover into gap of the chassis certainly.

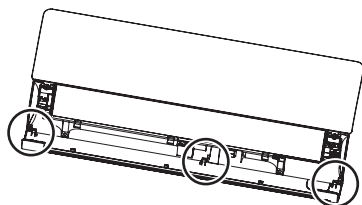
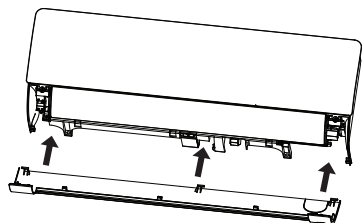

- 2 Push the hooks to assemble chassis cover. Push the chassis cover ① → ②.

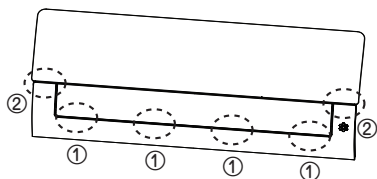

Good case

- Press on the tubing cover and unfold the tubing to downward slowly. And then bend to the left side slowly.

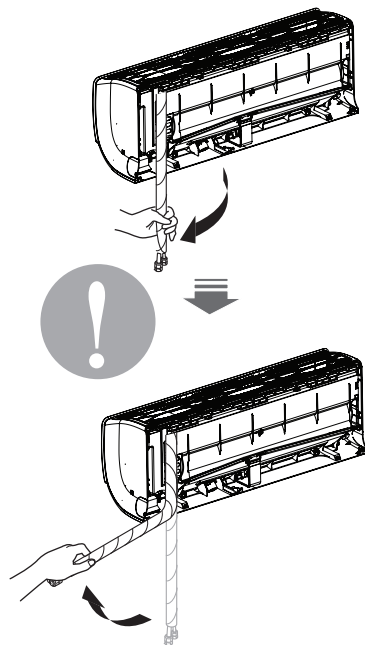

* The feature can be changed according to type of model.

Bad case

- Following bending case from right to left directly may cause damage to the tubing.

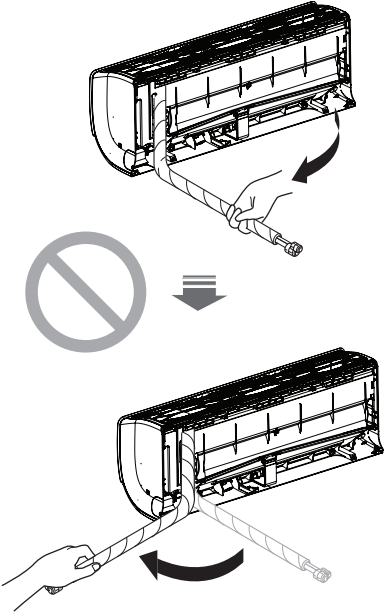

* The feature can be changed according to type of model.

CAUTION

Installation Information. For right piping. Follow the instruction above.

Installation of Indoor Unit(SJ/SK)

- 1 Hook the indoor unit onto the upper portion of the installation plate. (engage the three hooks at the top of the indoor unit with the upper edge of the installation plate) Ensure that the hooks are properly seated on the installation plate by moving it left and right.

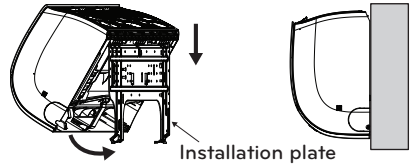

- 2 Unlock the tubing holder from the chassis and mount between the chassis and installation plate in order to separate the bottom side of the indoor unit from the wall.

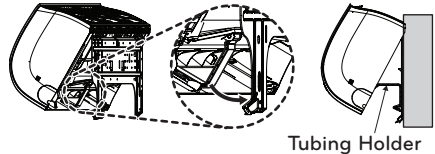

* The feature can be changed according to type of model.

Piping

- 1 Insert the connecting cable through the bottom side of indoor unit and connect the cable (You can see detail contents in 'Connecting the cables' section)

<Left side piping>

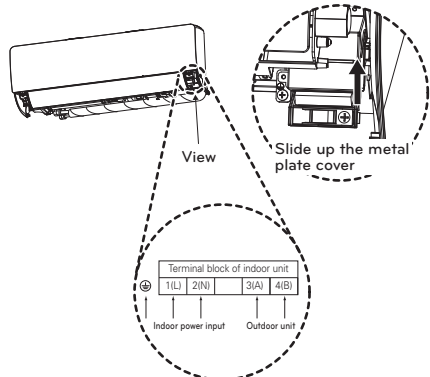

<Right side piping>

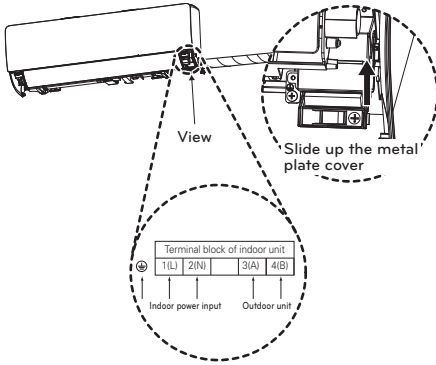

- 2 Secure the cable onto the control board with the cable retainer.
- 3 Tape the tubing pipe, drain hose and the connection cable. Be sure that the drain hose is located at the lowest side of the bundle. Locating at the upper side can cause overflow from the drain pan through the inside of the unit.

<Left side piping>

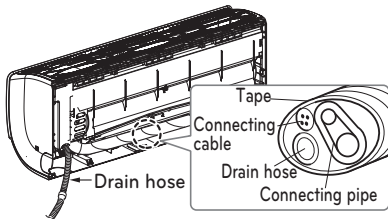

<Right side piping>

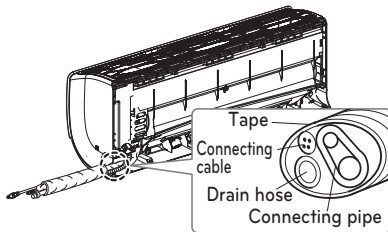

Connecting the Piping (SV)

- 1 Open the panel of the indoor unit.
- 2 Remove the chassis cover from the unit by loosening 5 screws.

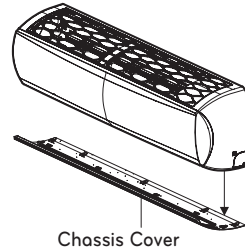
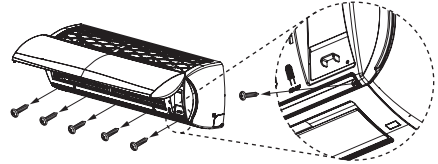

- 3 Pull back the tubing holder.
- 4 Remove the pipe port cover and position the piping.

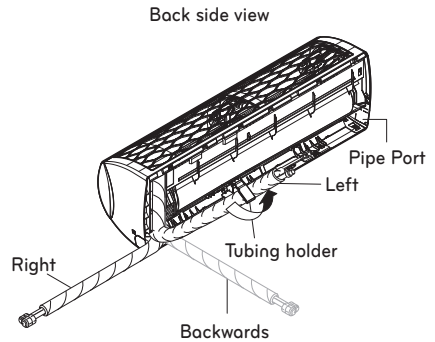

* The feature can be changed according to type of model.

Good case

- Press on the tubing cover and unfold the tubing to downward slowly. And then bend to the left side slowly.

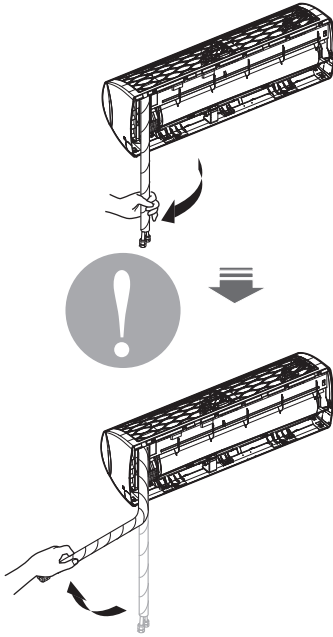

* The feature can be changed according to type of model.

Bad case

- Following bending case from right to left directly may cause damage to the tubing.

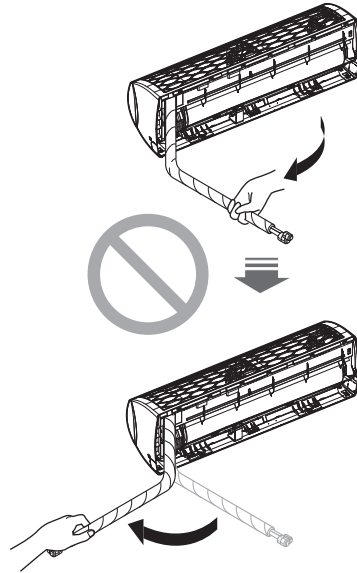

* The feature can be changed according to type of model.

CAUTION

Installation Information. For right piping. Follow the instruction above.

Installation of Indoor Unit(SV)

- Hook the indoor unit onto the upper portion of the installation plate.(engage the three hooks at the top of the indoor unit with the upper edge of the installation plate) Ensure that the hooks are properly seated on the installation plate by moving it left and right

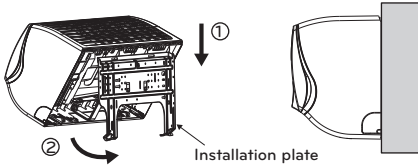

- Unlock the tubing holder from the chassis and mount between the chassis and installation plate in order to separate the bottom side of the indoor unit from the wall.

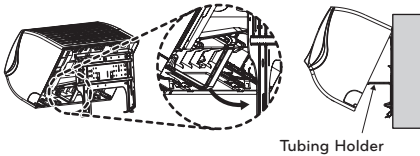

* The feature can be changed according to type of model.

Piping

- Insert the connecting cable through the bottom side of indoor unit and connect the cable (You can see detail contents in 'Connecting the cables' section)

<Left side piping>

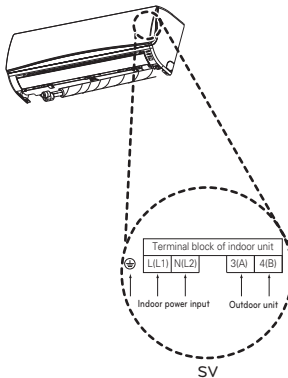

<Right side piping>

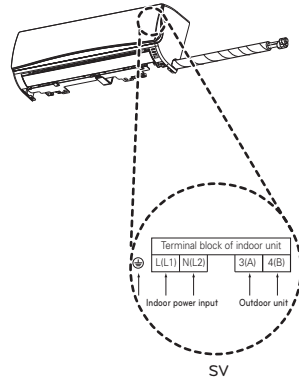

- Secure the cable onto the control board with the cable retainer.
- Tape the tubing pipe, drain hose and the connection cable. Be sure that the drain hose is located at the lowest side of the bundle. Locating at the upper side can cause overflow from the drain pan through the inside of the unit.

<Left side piping>

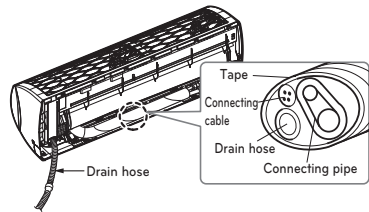

<Right side piping>

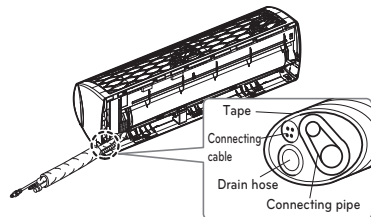

* The feature can be changed according to type of model.

CAUTION

If the drain hose is routed inside the room insulate the hose with an insulation material* so that dripping from sweating condensation* will not damage furniture or floors.

* Foamed polyethylene or equivalent is recommended.

Connecting the installation pipe and drain hose to the indoor unit.

- 1 Align the center of the pipes and sufficiently tighten the flare nut by hand

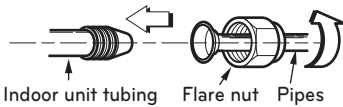

- 2 Tighten the flare nut with a wrench

Outside diameter		Torque
mm	inch	kgf.m
Ø 6.35	1/4	1.8~2.5
Ø 9.52	3/8	3.4~4.2
Ø 12.7	1/2	5.5~6.5
Ø 15.88	5/8	6.3~8.2
Ø 19.05	3/4	9.9~12.1

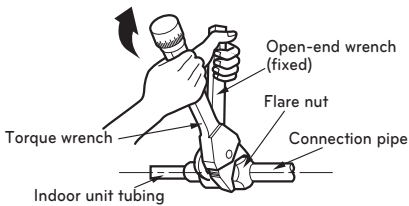

- 3 When needed to extend the drain hose of indoor unit, assembly the drain pipe as shown on the drawing

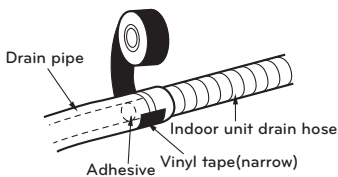

Wrap the insulation material around the connecting portion.

- 1 Overlap the connection pipe insulation material and the indoor unit pipe insulation material. Bind them together with vinyl tape so that there may be no gap.

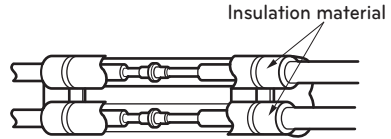

- 2 Set the tubing cutting line upward. Wrap the area which accommodates the rear piping housing section with vinyl tape.

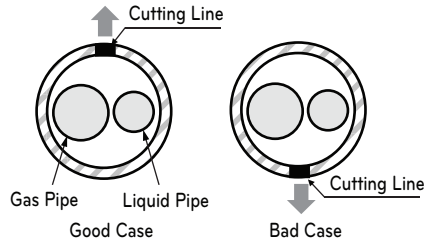

* Tubing cutting line have to be upward.

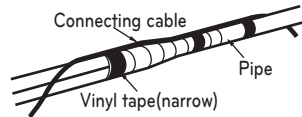
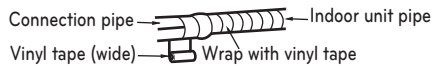

- 3 For left rear piping, bundle the piping and drain hose together by wrapping them cloth tape over the range within which they fit into the rear piping housing section.

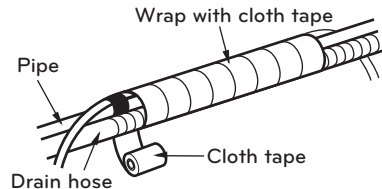

* Wrap the piping of the indoor unit that are visible from the outside with vinyl tape.

Finishing the indoor unit installation

- 1 Mount the tubing holder in the original position.
- 2 Ensure that the hooks are properly seated on the installation plate by moving it left and right.
- 3 Press the lower left and right sides of the unit against the installation plate until the hooks engage into their slots (clicking sound).
- 4 Finish the assembly by screwing the unit to the installation plate by using two pieces of type "C" screws. And assemble a chassis cover.

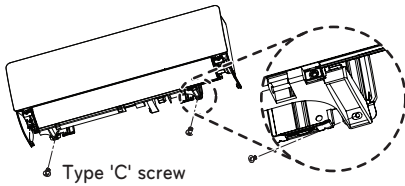
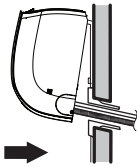

Checking the Drainage

To check the drainage

- 1 Pour a glass of water on the evaporator.
- 2 Ensure the water flows through the drain hose of the indoor unit without any leakage and goes out the drain exit.

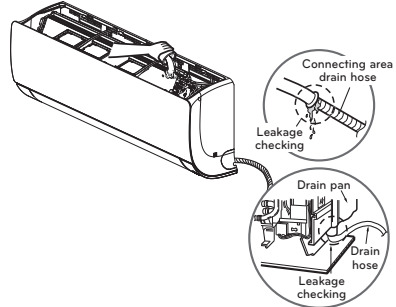

Drain piping

- 1 The drain hose should point downward for easy drain flow.

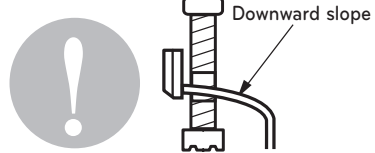

- 2 Do not make drain piping like the following.

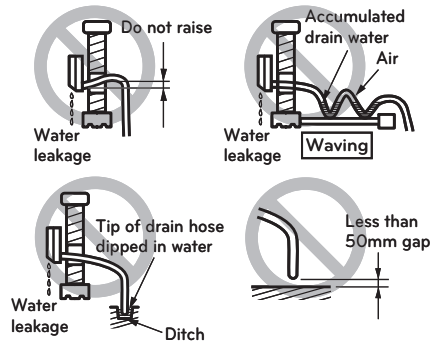

* The feature can be changed according to type of model.

Manual the decor, air filter Assembly & Disassembly SJ/SK Chassis

Disassemble the decor

- 1 Turn off the power and unplug the power cord.
- 2 Pull the decor at the bottom of the indoor unit.



- 3 Remove the decor from the indoor unit.



Assemble the decor

- 1 Turn off the power and unplug the power cord.
- 2 Insert 3 hooks of the decor into gap of the indoor unit certainly.

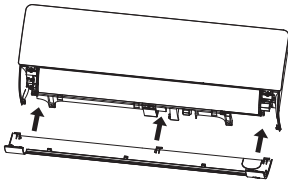

- 3 Push the hooks to assemble the decor.

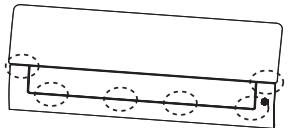

NOTE

- The air filter can be broken when it is bended.

Disassemble the air filter

- 1 Turn off the power and unplug the power cord.
- 2 Hold the knob of air filter, Lift it up slightly.



- 3 Hold the knob of the air filter, lift it up slightly and remove it from the unit.



Assemble the air filter

- 1 Turn off the power and unplug the power cord.
- 2 Insert the hooks of the air filter into the front grille.



- 3 Push down hooks to assemble the air filter.

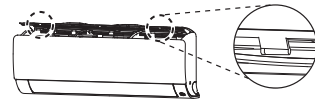

- 4 Check side of the front grille for the air filter assembled correctly.



NOTE

- If the air filter is not assembled correctly, Dust and othr substance come into the indoor unit. If look at the indoor unit from higher than it, can assemble the air filter easily

Installation of filters

SJ/SK Chassis

- 1 Pull out the [Allergy free filter + Triple Filter] from the separately packed plastic bag.
- 2 Detach the two nitto tapes from the filter.
- 3 Insert the filter into the filter case.
- 4 Detach two nitto tapes from the plasma filter.

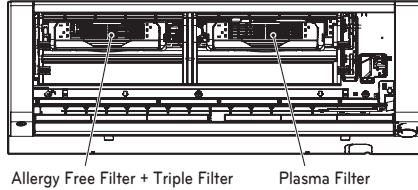

* The feature can be changed according to type of model.

Wiring Connection

- Connect the wires to the terminals on the control board individually according to the outdoor unit connection.
- Ensure that the color of the wires of outdoor unit and the terminal No. are the same as those of indoor unit respectively.
- The installation of a residual current device (RCD) having a rated residual operating current not exceeding 30 mA is advisable.

SJ/SK

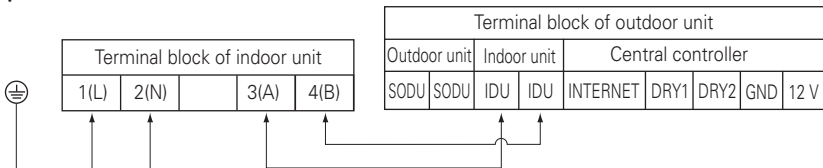

SV

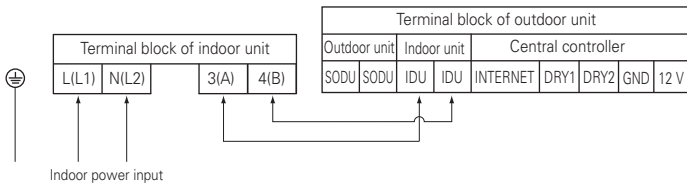

※ Resistance measurement position for incorrect wiring.

CAUTION

The connecting cable connected to the indoor and outdoor unit should be complied with the following specifications (This equipment shall be provided with a cable set complying with the national regulation).

If the supply cable is damaged, it must be replaced by a special cable or assembly available from the manufacturer of its service agent.

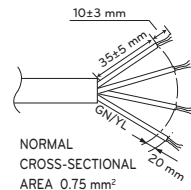

! WARNING

Make sure that the screws of the terminal are free from looseness.

! CAUTION

The Power cord connected to the unit should be selected according to the following specifications.

! CAUTION

Be sure to test the power line and communication line for incorrect wiring before power is applied.

- 1) If the power line and communication line are swapped over, the product will be damaged.
- 2) Incorrect wiring confirmation test method
 - : Measure the resistance across the power terminals (L,N) using a multi meter.
 - Resistance value of a normal connection: 1 MΩ or more
 - Incorrect wiring resistance value: 500 MΩ or less

! CAUTION

After the confirmation of the above conditions, prepare the wiring as follows:

- 1) Never fail to have separate power specially for the air conditioner. As for the method of wiring, follow the circuit diagram pasted on the inside of control box cover.
- 2) Provide a circuit breaker switch between power source and the unit.
- 3) The screw which fasten the wiring in the casing of electrical fittings are liable to come loose from vibrations to which the unit is subjected during the course of transportation. Check them and make sure that they are all tightly fastened. (If they are loose, it could give rise to burn-out of the wires.)
- 4) Confirm the Specification of power source
- 5) Confirm that electrical capacity is sufficient.
- 6) Be sure that the starting voltage is maintained at more than 90 percent of the rated voltage marked on the name plate.
- 7) Confirm that the cable thickness is as specified in the power sources specification. (Particularly note the relation between cable length and thickness.)
- 8) Do not install the leakage breaker in a place which is wet or moist. Water or moist may cause short circuit.
- 9) The following troubles would be caused by voltage drop-down.
 - Vibration of a magnetic switch, damage on the contact point there of, fuse breaking, disturbance to the normal function of a overload protection device.
 - Proper starting power is not given to the compressor.
- 10) Before applying power to the indoor unit, be sure to check for incorrect wiring of the power and communication lines.

DIP Switch Setting

Indoor Unit

	Function	Description	Setting Off	Setting On	Default
SW1	Communication	N/A (Default)	-	-	Off
SW2	Cycle	N/A (Default)	-	-	Off
SW3	Group Control	Selection of Master or Slave	Master	Slave	Off
SW4	Dry Contact Mode	Selection of Dry Contact Mode	Wired/Wireless remote controller Selection of Manual or Auto operation Mode	Auto	Off
SW5	Installation	Fan continuous operation	Continuous operation Removal	-	Off
SW6	Heater linkage	N/A	-	-	Off
SW7	Ventilator linkage	Selection of Ventilator linkage	Linkage Removal	Working	Off
	Vane selection (Console)	Selection of up/down side Vane	Up side + Down side Vane	Up side Vane Only	
	Region selection	Selection tropical region	General model	Tropical model	
SW8	Etc.	Spare	-	-	Off



CAUTION

For Multi V Models, DIP switch 1, 2, 6, 8 must be set OFF.

Group Control Setting

Group Control 1

■ Wired remote controller 1 + Standard Indoor Units

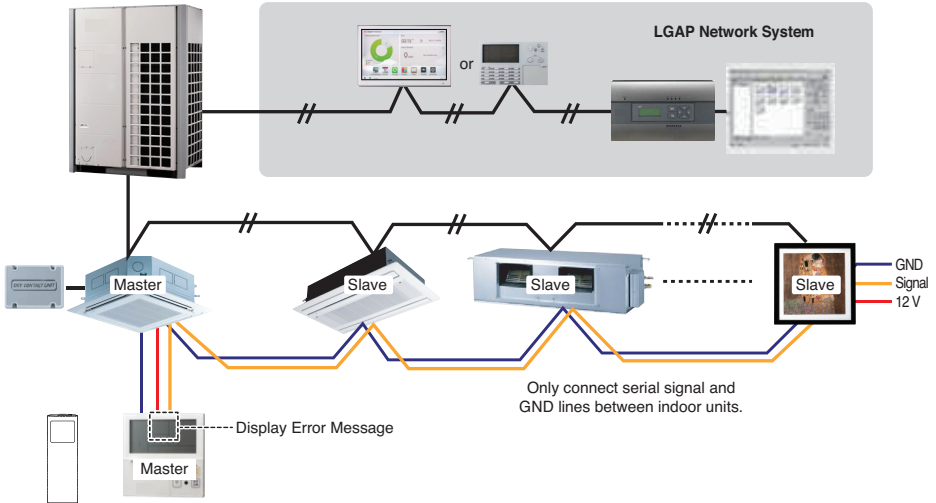

■ DIP Switch in PCB

① Master Setting
- No. 3 Off

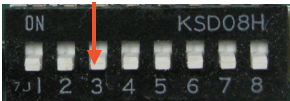

② Slave Setting
- No. 3 On

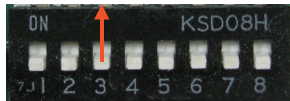

Indoor Unit DIP Switch

Some products have no DIP switch on PCB. It is possible to set indoor units to Master or Slave by using the wireless remote controller instead of DIP switch.

For the details of the setting, please refer to the manual of the wireless remote controller.

1. It is possible to 16 indoor units(Max.) by one wired remote controller.
Set only one indoor unit to Master, set the others to Slave.
2. It is possible to connect with every type of indoor units.
3. It is possible to use wireless remote controller at the same time.
4. It is possible to connect with Dry Contact and Central controller at the same time.
- The Master indoor unit is possible to recognize Dry Contact and Central Controller only.
5. In case that any error occurs at indoor unit, the error code is displayed on the wired remote controller.
It is possible to control the other indoor units except the error units.

- * It is possible to connect indoor units since Feb. 2009.
- * It can be the cause of malfunctions when there is no setting of master and slave.
- * In case of Group Control, it is possible to use following functions.
 - Selection of operation, stop or mode
 - Temperature setting and room temperature check
 - Current time change
 - Control of flow rate (High/Middle/Low)
 - Reservation settings
 - It is not possible at some functions.

Group Control 2

■ Wired remote controllers + Standard Indoor Units

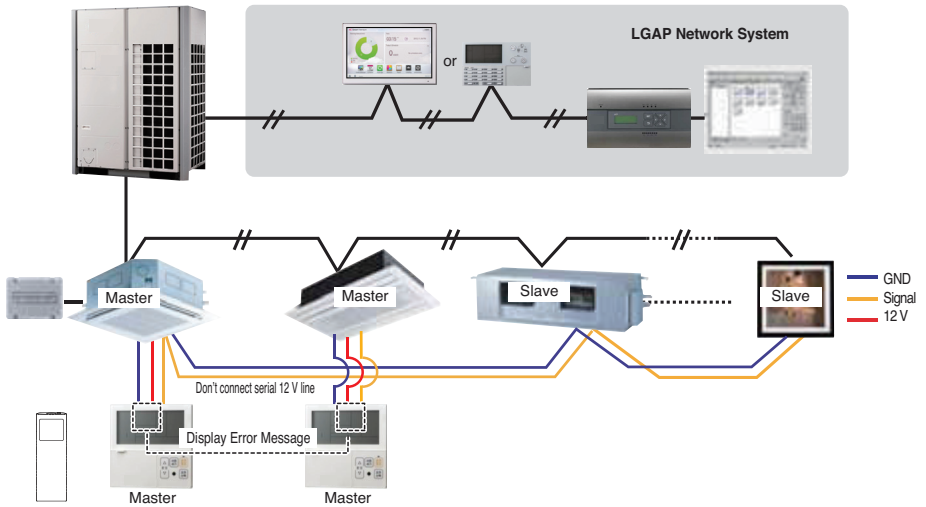

- * It is possible to control 16 indoor units(Max.) with the master wired remote control.
- * Other than those, it is same with the Group Control 1.

Group Control 3

■ Mixture connection with indoor units and Fresh Air Intake Unit

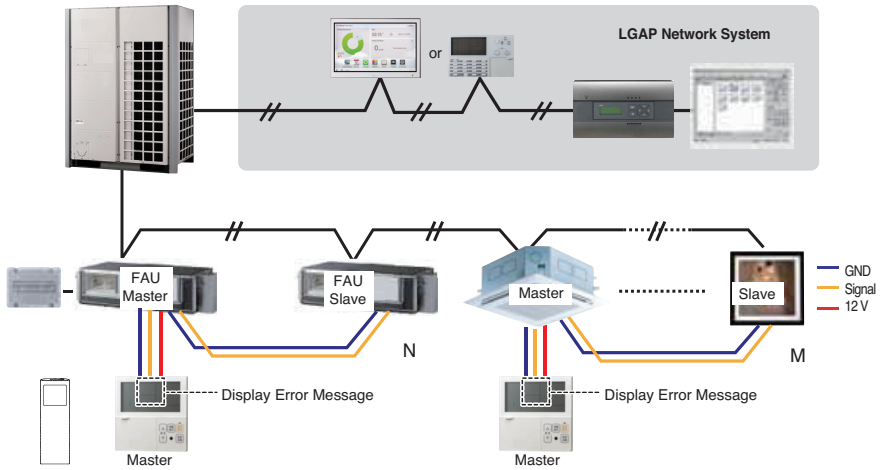

* In case of connecting with standard indoor unit and Fresh Air Intake Unit, separate Fresh Air Intake Unit with standard units. ($N, M \leq 16$) (Because setting temperature are different.)

* Other than those, it is same with Group Control 1.

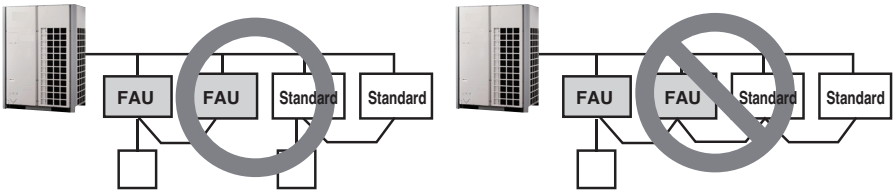

* FAU : Fresh Air Intake Unit
Standard: Standard Indoor Unit

2 Remote Control

■ Wired remote controller 2 + Indoor unit 1

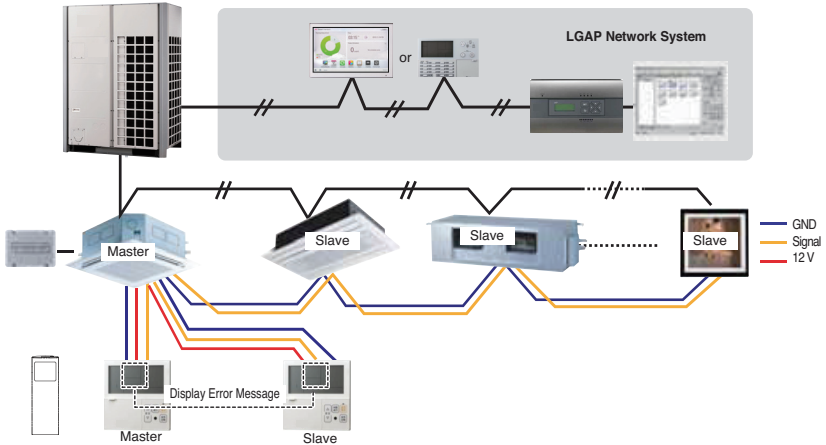

1. It is possible to connect two wired remote controllers (Max.) with one indoor unit.
Set only one indoor unit to Master, set the others to Slave.
Set only one wired remote controller to Master, set the others to Slave.
2. Every types of indoor unit is possible to connect two remote controller.
3. It is possible to use wireless remote controller at the same time.
4. It is possible to connect with Dry Contact and Central controller at the same time.
5. In case that any error occurs at indoor unit, the error code is displayed on the wired remote controller.
6. There isn't limits of indoor unit function.

Accessories for group control setting

It is possible to set group control by using below accessories.

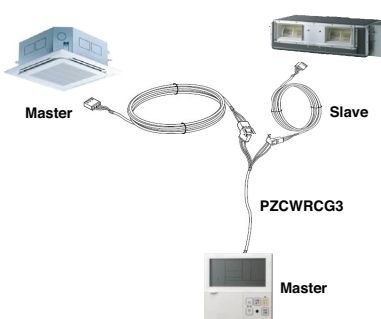
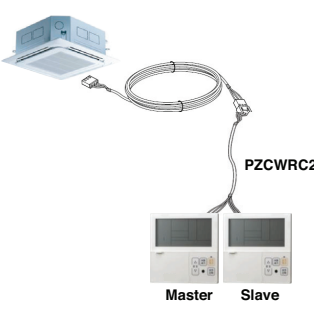
Indoor unit 2 EA + Wired remote controller 1 EA	Indoor unit 1 EA + Wired remote controller 2 EA
<p>* PZCWRCG3 cable used for connection</p>  <p>The diagram illustrates the PZCWRCG3 cable configuration. It shows a ceiling-mounted indoor unit labeled 'Master' on the left. A cable labeled 'PZCWRCG3' runs from this unit to a remote controller labeled 'Slave' on the right. Another cable labeled 'PZCWRCG3' runs from the same indoor unit to a second indoor unit labeled 'Master' at the bottom.</p>	<p>* PZCWRC2 cable used for connection</p>  <p>The diagram illustrates the PZCWRC2 cable configuration. It shows a ceiling-mounted indoor unit labeled 'Master' on the left. A cable labeled 'PZCWRC2' runs from this unit to a remote controller labeled 'Slave' on the right. Another cable labeled 'PZCWRC2' runs from the same indoor unit to a second indoor unit labeled 'Master' at the bottom, which is also connected to a remote controller labeled 'Slave'.</p>

⚠ CAUTION

Apply totally enclosed noncombustible conduit in case of local building code Requiring plenum cable usage.

Model Designation

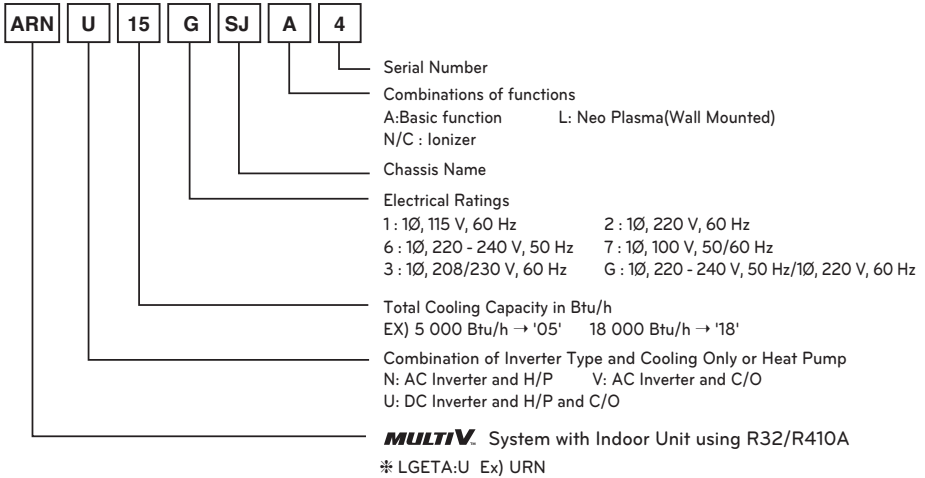

Airborne Noise Emission

The A-weighted sound pressure emitted by this product is below 70 dB.

** The noise level can vary depending on the site.

The figures quoted are emission level and are not necessarily safe working levels. Whilst there is a correlation between the emission and exposure levels, this cannot be used reliably to determine whether or not further precautions are required. Factor that influence the actual level of exposure of the workforce include the characteristics of the work room and the other sources of noise, i.e. the number of equipment and other adjacent processes and the length of time for which an operator exposed to the noise. Also, the permissible exposure level can vary from country to country. This information, however, will enable the user of the equipment to make a better evaluation of the hazard and risk.

Limiting concentration

Limiting concentration is the limit of Freon gas concentration where immediate measures can be taken without hurting human body when refrigerant leaks in the air. The limiting concentration shall be described in the unit of kg/m^3 (Freon gas weight per unit air volume) for facilitating calculation

Limiting concentration: 0.44 kg/m^3 (R410A)

■ Calculate refrigerant concentration

$$\text{Refrigerant concentration} = \frac{\text{Total amount of replenished refrigerant in refrigerant facility (kg)}}{\text{Capacity of smallest room where indoor unit is installed (m}^3\text{)}}$$



Manufacturer :
LG Electronics Inc.
84, Wanam-ro, Seongsan-gu, Changwon-si, Gyeongsangnam-do, KOREA

UK Importer : LG Electronics U.K. Ltd
Velocity 2, Brooklands Drive, Weybridge, KT13 0SL

Eco design requirement

- The information for Eco design is available on the following free access website.
<https://www.lg.com/global/support/cedoc/cedoc>