



INSTALLATION MANUAL

AIR CONDITIONER

Please read this installation manual completely before installing the product. Installation work must be performed in accordance with the national wiring standards by authorized personnel only.

Please retain this installation manual for future reference after reading it thoroughly.

Hydro Kit Wall mounted (medium temperature)
Original instruction



MFL67086714
Rev.06_090825

Copyright © 2020 - 2025 LG Electronics Inc. All Rights Reserved.

www.lg.com

РУССКИЙ ЯЗЫК

ENGLISH

УКРАЇНСЬКА

ITALIANO

ҚАЗАҚ ТІЛІ

ESPAÑOL

БЕЛАРУСКАЯ МОВА

FRANÇAIS

О'ЗБЕК ТИЛИ

DEUTSCH

ЕАМНІКА

ČEŠTINA

NEDERLANDS

POLSKI

LIMBA ROMÂNĂ

TABLE OF CONTENTS

4 SAFETY INSTRUCTIONS

12 INSTALLATION PART

13 GENERAL INFORMATION

- 13 Model Information
- 13 Accessories

16 INSTALLATION

- 16 Transporting the Unit
- 16 Selection of the best location

20 INSTALLATION OF INDOOR UNIT

- 20 Conditions where Indoor Unit is Installed

23 PIPING AND WIRING FOR INDOOR UNIT

- 23 Water Piping and Water Circuit Connection
- 26 Water pump Capacity
- 26 Pressure Drop
- 28 Typical Installation Example
- 31 Water cycle
- 33 Water Quality
- 33 Frost protection
- 34 Preparation for Piping
- 35 Electrical Wiring
- 36 Wiring Connection
- 39 Connecting Cables

40 ACCESSORIES INSTALLATION

- 40 Before Installation
- 40 Thermostat
- 44 DHW Tank
- 47 Solar Thermal Kit
- 48 Dry Contact
- 50 External Controller - Setting up programmable digital input operation
- 51 Remote Temperature Sensor
- 53 Solar pump
- 54 Wi-fi Modem
- 55 2Way Valve
- 56 3Way Valve(A)
- 57 3Way Valve(B)
- 58 Final check





59 SYSTEM SET-UP

- 59 DIP Switch Setting

64 SERVICE SETTING

64	How to enter service setting
64	Service setting
65	Service contact
66	Model information
67	RMC version Information
68	Open source license
69	Installer setting
71	3 Minutes Delay
72	Select Temperature Sensor
73	Dry Contact Mode
74	Pump test run
75	Air cooling set temp.
76	Water cooling set temp.
77	Air heating set temp.
78	Water heating set temp.
79	DHW set temp.
80	Water supply off temp. during cooling
82	Heater priority
83	DHW time setting
84	TH on/off Variable, heating air
85	TH on/off Variable, heating water
86	TH on/off Variable, cooling air
87	TH on/off Variable, cooling water
88	Heating temp. setting
89	Cooling temp. setting
90	Pump setting in heating
91	Pump setting. in cooling
92	Forced operation
93	CN_CC
94	Pump frequency setting (RPM)
95	Pump Capacity
96	CN_EXT
97	Anti-freezing Temperature
98	Pump Prerun/Overrun
99	Solar Thermal System
101	Current flow rate
102	Data logging
103	Password Initialization
104	Troubleshooting
107	Airborne Noise Emission
107	Model Designation

SAFETY INSTRUCTIONS

	Read the precautions in this manual carefully before operating the unit.		This appliance is filled with flammable refrigerant (R32)
	This symbol indicates that the Operation Manual should be read carefully.		This symbol indicates that a service personnel should be handling this equipment with reference to the Installation Manual.

The following safety guidelines are intended to prevent unforeseen risks or damage from unsafe or incorrect operation of the appliance. The guidelines are separated into 'WARNING' and 'CAUTION' as described below.

 This symbol is displayed to indicate matters and operations that can cause risk. Read the part with this symbol carefully and follow the instructions in order to avoid risk.

WARNING

This indicates that the failure to follow the instructions can cause serious injury or death.

CAUTION

This indicates that the failure to follow the instructions can cause the minor injury or damage to the product.

WARNING

Installation

- Compliance with national gas regulations shall be observed.
- Do not use a defective or underrated circuit breaker. Use this appliance on a dedicated circuit.
 - There is risk of fire or electric shock.

- For electrical work, contact the dealer, seller, a qualified electrician, or an Authorized Service Center.
 - There is risk of fire or electric shock.
- Always ground the unit.
 - There is risk of fire or electric shock.
- Install the panel and the cover of control box securely.
 - There is risk of fire or electric shock.
- Always install a dedicated circuit and breaker.
 - Improper wiring or installation may cause fire or electric shock.
- Be cautious when unpacking and installing the product.
 - Sharp edges could cause injury. Be especially careful of the case edges and the fins on the condenser and evaporator.
- Use the correctly rated breaker or fuse.
 - There is risk of fire or electric.
- Do not modify or extend the power cable.
 - There is risk of fire or electric shock.
- Do not install, remove, or reinstall the unit by yourself (customer).
 - There is risk of fire, electric shock, explosion, or injury.
- For antifreeze, always contact the dealer or an authorized service center.
 - Almost the antifreeze is a toxic product.
- For installation, always contact the dealer or an Authorized Service Center.
 - There is risk of fire, electric shock, explosion, or injury.
- Do not install the unit on a defective installation stand.
 - It may cause injury, accident, or damage to the unit.
- Do not turn on the breaker or power under condition that front panel, cabinet, top cover, control box cover are removed or opened.
 - Otherwise, it may cause fire, electric shock, explosion or death.

- Be sure the installation area does not deteriorate with age.
 - If the base collapses, the unit could fall with it, causing property damage, unit failure, and personal injury.
- Do not install the unit outdoor.
 - It may cause damage to the unit.
- Use a vacuum pump or inert (nitrogen) gas when doing leakage test or purging air. Do not compress air or oxygen and do not use flammable gases.
 - There is the risk of death, injury, fire or explosion.
- The appliance shall be stored in a well-ventilated area where the room size corresponds to the room area as specified for operation. (for R32)
- Ducts connected to an appliance shall not contain an ignition source. (for R32)
- The appliance shall be stored in a room without continuously operating ignition sources (for example: open flames, an operating gas appliance or an operating electric heater.)
- Means for disconnection must be incorporated in the fixed wiring in accordance with the wiring rules.
- This equipment shall be provided with a supply conductor complying with the national regulation.
- Have all electric work done by a licensed electrician according to "Electric Facility Engineering Standard" and "Interior Wire Regulations" and the instructions given in this manual and always use a special circuit.
 - If the power source capacity is inadequate or electric work is performed improperly, electric shock or fire may result.
- Always install a dedicated circuit and breaker.
 - Improper wiring or installation may cause fire or electric shock.
- Keep any required ventilation openings clear of obstruction.
- Mechanical connections shall be accessible for maintenance purposes.

- To prevent the mixing of different types of refrigerants, be sure to check the type of refrigerant used in the outdoor unit.
- When mechanical connectors are reused indoors, sealing parts shall be renewed. (for R32)
- When flared joints are reused indoors, the flare part shall be re-fabricated. (for R32)

Operation

- Do not let the air conditioner run for a long time when the humidity is very high and a door or a window is left open.
 - Moisture may condense and wet or damage furniture.
- Take care to ensure that power cable could not be pulled out or damaged during operation.
 - There is risk of fire or electric shock.
- Do not place anything on the power cable.
 - There is risk of fire or electric shock.
- Do not plug or unplug the power supply plug during operation.
 - There is risk of fire or electric shock.
- Do not touch (operate) the unit with wet hands.
 - There is risk of fire or electric shock.
- Do not place a heater or other appliances near the power cable.
 - There is risk of fire or electric shock.
- Do not allow water to run into electric parts.
 - There is risk of fire, failure of the unit, or electric shock.
- Do not store or use flammable gas or combustibles near the unit.
 - There is risk of fire or failure of unit.
- Do not use the product in a tightly closed space for a long time.
 - Oxygen deficiency could occur.

- When flammable gas leaks, turn off the gas and open a window for ventilation before turning the unit on.
 - There is risk of explosion or fire.
- If strange sounds, or smell or smoke comes from unit, turn the breaker off or disconnect the power supply cable.
 - There is risk of electric shock or fire.
- Stop operation and close the window in storm or hurricane. If possible, remove the unit from the window before the hurricane arrives.
 - There is risk of property damage, failure of unit, or electric shock.
- Do not open the front cover of the unit while operation. (Do not touch the electrostatic filter, if the unit is so equipped.)
 - There is risk of physical injury, electric shock, or unit failure.
- When the unit is soaked (flooded or submerged), contact an Authorized Service Center.
 - There is risk of fire or electric shock.
- Be cautious that water could not enter the product.
 - There is risk of fire, electric shock, or product damage.
- Ventilate the unit from time to time when operating it together with a stove, etc.
 - There is risk of fire or electric shock.
- Turn the main power off when cleaning or maintaining the unit.
 - There is risk of electric shock.
- Take care to ensure that nobody could step on or fall onto the unit.
 - This could result in personal injury and unit damage.
- For installation, always contact the dealer or an Authorized Service Center.
 - There is risk of fire, electric shock, explosion, or injury.
- If the unit is not used for long time, we strongly recommend not to switch off the power supply to the unit.
 - There is risk of water freezing.

- Periodic (more than once/year) cleaning of the dust or salt particles stuck on the heat exchanger by using water.
- Do not use means to accelerate the defrosting process or to clean, other than those recommended by the manufacturer.
- Do not pierce or burn refrigerant cycle part.
- Be aware that refrigerants may not contain an odour.

CAUTION

Installation

- Always check for gas (refrigerant) leakage after installation or repair of unit.
 - Low refrigerant levels may cause failure of unit.
- Keep level even when installing the unit.
 - To avoid vibration or water leakage.
- Use two or more people to lift and transport the unit.
 - Avoid personal injury.
- Any person who is involved with working on or breaking into a refrigerant circuit should hold a current valid certificate from an industry accredited assessment authority, which authorises their competence to handle refrigerants safely in accordance with an industry recognised assessment specification. (for R32)
- The appliance shall be stored so as to prevent mechanical damage from occurring.
- If anyone other than a licensed Professional installs, repairs, or alters LG Electronics Air Conditioning Products, the warranty is voided.
 - All costs associated with repair are then the full responsibility of the owner.
- Do not install the product where it will be exposed to sea wind (salt spray) directly.
 - It may cause corrosion on the product. Corrosion, particularly on the condenser and evaporator fins, could cause product malfunction or inefficient operation.

- Refrigerant tubing shall be protected or enclosed to avoid damage.
- Flexible refrigerant connectors (such as connecting lines between the indoor and outdoor unit) that may be displaced during normal operations shall be protected against mechanical damage.
- The installation of pipe-work shall be kept to a minimum.
- Pipe-work shall be protected from physical damage.
- A brazed, welded, or mechanical connection shall be made before opening the valves to permit refrigerant to flow between the refrigerating system parts.
- Dismantling the unit, treatment of the refrigerant oil and eventual parts should be done in accordance with local and national standards.
- Do not install the unit in potentially explosive atmospheres.

Operation

- Do not lay on the cooled floor for long time when the unit is in cooling operation.
 - This could harm to your health.
- Do not use the unit for special purposes, such as preserving foods, works of art, etc.
 - There is risk of damage or loss of property.
- Use a soft cloth to clean. Do not use harsh detergents, solvents, etc.
 - There is risk of fire, electric shock, or damage to the plastic parts of the unit.
- Do not step on or put anything on the unit.
 - There is risk of personal injury and failure of unit.
- Use a firm stool or ladder when cleaning or maintaining the unit.
 - Be careful and avoid personal injury.



- Servicing shall only be performed as recommended by the equipment manufacturer. Maintenance and repair requiring the assistance of other skilled personnel shall be carried out under the supervision of the person competent in the use of flammable refrigerants. (for R32)
- Do not unplug the power supply plug of Hydro Kit when stopping Hydro Kit operation. Always turn Hydro Kit off, using the wired remote controller.
 - A plate heat exchanger burst may happen because of disconnection of communication between Hydro Kit and the outdoor unit.

INSTALLATION PART

Thank you for choosing LG Electronics Air-to-Water Heat Pump **Hydro Kit**

Before starting installation, please make it sure that all parts are found inside the product box.

INDOOR UNIT BOX

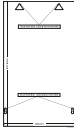
Item	Image
Indoor unit	
Owner's / Installation manual	
Installation Sheet	

GENERAL INFORMATION

With advanced inverter technology, **Hydro Kit** is suitable for applications like under floor heating, and hot water generation. By Interfacing to various accessories user can customize the range of the application.

Model Information

Model name and related information

Model Name			Built-In Electric Heater(kW)	Power Source (Electric Heater)	Power Source (Unit)
Refrigerant	Indoor Unit				
	Phase	Capacity (kW)			
R410A / R32	1Ø	5.6	6 (3+3)	220-240 V~ 50 Hz	220-240 V~ 50 Hz
		7.1			
		9.0			

Accessories

To extend the functionality of **Hydro Kit**, there are various external auxiliary apparatus called as "accessories".

They are classified by "accessories" and "3rd party accessories" according to the manufacturer. Accessories are presented LG Electronics, and 3rd party accessories are presented by related manufacturers.

Accessories supported by LG Electronics

Item	Purpose	Model
DHW Tank Kit	To operate with DHW tank	PHLTA : 1Ø PHLTC : 3Ø
Remote Air Sensor	To control by air temperature	PQRSTA0
Dry Contact	To receive on & off external signal	PDRYCB500
	Dry Contact For Thermostat	PDRYCB300
Solar Thermal Kit	To operate with solar heating system	PHLLA(Limit temperature : 96 °C)
DHW Tank	To generate and store hot water	PHS02060310 : 200 liter, Single Heating Coil, 1Ø 230 V 50 Hz 3 kW Electric Heater PHS02060320 : 200 liter, Double Heating Coil, 1Ø 230 V 50 Hz 3 kW Electric Heater PHS03060310 : 300 liter, Single Heating Coil, 1Ø 230 V 50 Hz 3 kW Electric Heater PHS03060320 : 300 liter, Double Heating Coil, 1Ø 230 V 50 Hz 3 kW Electric Heater
Thermistor for DHW Tank	To control hot water temperature of DHW tank	PHRSTA0
Drain Pan	To prevent drain water drop	PHDPB
Central Controller	Multiple installed products into one central control	
Wi-Fi Modem	To enable remote system operation from smartphone	PWFMDD200
Extension wire	To connect remote controller with Indoor PCB for communication	PZCWRC1
Cover Plate	To relocate remote controller from indoor unit	PDC-HK10

Accessories supported by 3rd party Companies

Item	Purpose	Specification
Solar Heating System	To generate auxiliary heating energy for water tank	<ul style="list-style-type: none"> • Solar collector • 3way valve(B)
Thermostat	To control by air temperature	Heating-Only type (230 V AC) Cooling/Heating type (230 V AC with Mode selection switch)
3 rd Party Controller	To connect external controller using modbus protocol	
3way valve and actuator	(A) : To control water flow for hot water heating or floor heating / To control water flow when installing 3rd party boiler (B) : To control close/open mode of solar circuit	3 wire, SPDT (Single Pole Double Throw) type, 230 V AC
2way valve and actuator	To control water flow for Fan Coil Unit	2 wire,NO(Normal Open) or NC(Normal Closed) type, 230 V AC

INSTALLATION

Transporting the Unit

CAUTION

Be very careful while carrying the unit.

- Do not have only one person carry the unit if it is more than 20 kg (44.1 lbs).
- PP bands are used to pack some products. Do not use them as a mean for transportation because they are dangerous.
- Tear plastic packaging bag and scrap it so that children cannot play with it. Otherwise plastic packaging bag may suffocate children to death.
- When carrying the unit, be sure to support it at 6-points. Carrying and lifting the unit with 4-point support may make it unstable, resulting in a fall.

Selection of the best location

Select space for installing the unit, which will meet the following conditions:

The place where the unit shall be installed inside.

The place shall easily bear a load exceeding four times of the unit weight.

The place where the unit shall be leveled.

The place shall allow easy water drainage.

The place where the unit shall be connected to the outdoor unit.

The place where the unit is not affected by an electrical noise.

The place where there should not be any heat source or steam near the unit.

Minimum floor area (for R32)

- The appliance shall be installed, operated and stored in a room with a floor area larger than the minimum area.
- Use the graph of table to determine the minimum area.

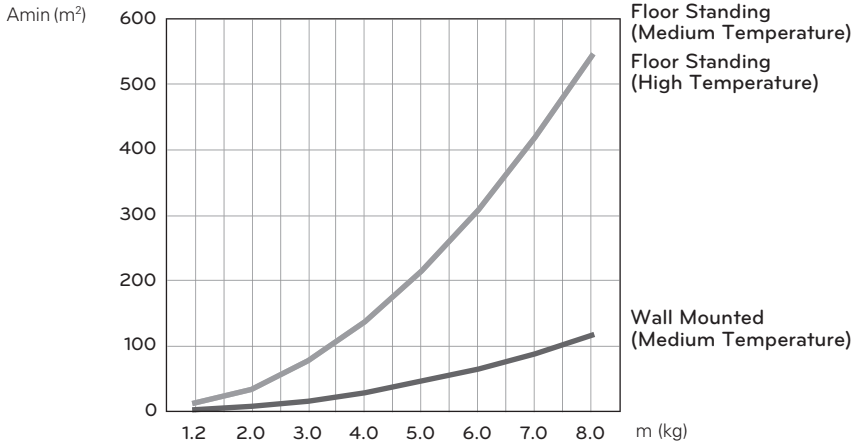

- m : Total refrigerant amount in the system
- Total refrigerant amount : factory refrigerant charge + additional refrigerant amount
- Amin : minimum area for installation

m (kg)	Wall Mounted	Floor Standing
	(h0 = 1.3)	(h0 = 0.6)
	A _{min} (m ²)	
< 1.224	-	-
1.224	2.74	12.86
1.40	3.58	16.82
1.60	4.68	21.97
1.80	5.92	27.80
2.00	7.31	34.32
2.20	8.85	41.53
2.40	10.53	49.42
2.60	12.36	58.00
2.80	14.33	67.27
3.00	16.45	77.22
3.20	18.72	87.86
3.40	21.13	99.19
3.60	23.69	111.20
3.80	26.39	123.90
4.00	29.24	137.29
4.20	32.24	151.36
4.40	35.39	166.12
4.60	38.68	181.56

m (kg)	Wall Mounted	Floor Standing
	(h0 = 1.3)	(h0 = 0.6)
	A _{min} (m ²)	
4.80	42.11	197.70
5.00	45.70	214.51
5.20	49.42	232.02
5.40	53.30	250.21
5.60	57.32	269.09
5.80	61.49	288.65
6.00	65.80	308.90
6.20	70.26	329.84
6.40	74.87	351.46
6.60	79.62	373.77
6.80	84.52	396.76
7.00	89.56	420.45
7.20	94.75	444.81
7.40	100.09	469.87
7.60	105.57	495.61
7.80	111.20	522.04
7.956	115.70	543.13
39 > m > 7.956	Ventilation	Ventilation

If this product is installed in the a room smaller than minimum floor area, there shall be continuously operated mechanical ventilation system or natural ventilation openings (for R32).

Natural ventilation

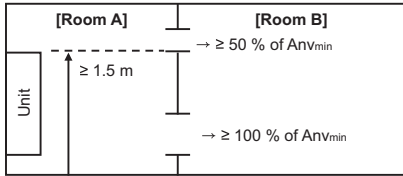

The floor area of "Room A + Room B" is considered as floor area instead of "room A" for complying with minimum floor area " A_{min} "

- Openings are permanent openings which cannot be closed.

Bottom opening:

- The area of any openings above 300 mm from the floor shall not be considered in determining compliance with AnV_{min} .
- At least 50 % of the required opening area AnV_{min} shall be below 200 mm from the floor.
- The bottom of the lowest openings shall not be higher than 100 mm from the floor.
- If the openings starts from the floor, the height must be higher than 20 mm.

Top opening:

- The total size of the top opening shall not be less than 50 % of minimum opening area for AnV_{min} and shall be at least 1.5 m above the floor.

- AnV_{min} : the minimum opening for natural ventilation

Wall Mounted (Medium temperature)			
m (kg)	AnV_{min} (cm ²)	m (kg)	AnV_{min} (cm ²)
1.224	99.2	4.8	660.2
1.4	126.8	5.0	691.6
1.6	158.2	5.2	723.0
1.8	189.6	5.4	754.3
2.0	220.9	5.6	785.7
2.2	252.3	5.8	817.1
2.4	283.7	6.0	848.5
2.6	315.1	6.2	879.8
2.8	346.4	6.4	911.2
3.0	377.8	6.6	942.6
3.2	409.2	6.8	974.0
3.4	440.6	7.0	1005.3
3.6	471.9	7.2	1036.7
3.8	503.3	7.4	1068.1
4.0	534.7	7.6	1099.5
4.2	566.1	7.8	1130.9
4.4	597.5	8.0	1162.2
4.6	628.8		

Floor Standing (Medium temperature)			
m (kg)	AnV_{min} (cm ²)	m (kg)	AnV_{min} (cm ²)
1.224	225.6	4.8	1114.7
1.4	269.4	5.0	1164.4
1.6	319.1	5.2	1214.2
1.8	368.8	5.4	1263.9
2.0	418.5	5.6	1313.6
2.2	468.3	5.8	1363.3
2.4	518.0	6.0	1413.1
2.6	567.7	6.2	1462.8
2.8	617.4	6.4	1512.5
3.0	667.2	6.6	1562.2
3.2	716.9	6.8	1612.0
3.4	766.6	7.0	1661.7
3.6	816.4	7.2	1711.4
3.8	866.1	7.4	1761.1
4.0	915.8	7.6	1810.9
4.2	965.5	7.8	1860.6
4.4	1015.3	8.0	1910.3
4.6	1065.0		

Floor Standing (High Temperature)			
m (kg)	AnV_{min} (cm ²)	m (kg)	AnV_{min} (cm ²)
1.224	229.4	4.8	1187.4
1.4	276.6	5.0	1241.0
1.6	330.2	5.2	1294.5
1.8	383.7	5.4	1348.1
2.0	437.3	5.6	1401.7
2.2	490.9	5.8	1455.3
2.4	544.5	6.0	1508.9
2.6	598.0	6.2	1562.4
2.8	651.6	6.4	1616.0
3.0	705.2	6.6	1669.6
3.2	758.8	6.8	1723.2
3.4	812.4	7.0	1776.7
3.6	865.9	7.2	1830.3
3.8	919.5	7.4	1883.9
4.0	973.1	7.6	1937.5
4.2	1026.7	7.8	1991.0
4.4	1080.2	8.0	2044.6
4.6	1133.8		

- Wall Mounted(Medium Temperature) : ARNH**GK1A4
- Floor Standing(Medium Temperature) : ARNH**GK2A4
- Floor Standing(High Temperature) : ARNH**GK3A4

Mechanical ventilation

If there is a mechanical ventilation system that satisfies with minimum air flow, a product can be installed in the room smaller than the minimum floor area.

- The room shall comply with machinery room's requirements of ISO 5149.

m (kg)	min.air flow (m ³ /h)
<1.224	-
1.224	57.2
1.4	62.5
1.6	68.4
1.8	73.9
2.0	79.3
2.2	84.5
2.4	89.6
2.6	94.5
2.8	99.3
3.0	103.9
3.2	108.5
3.4	113.0
3.6	117.4
3.8	121.7
4.0	125.9
4.2	130.1
4.4	134.2

m (kg)	min.air flow (m ³ /h)
4.6	138.2
4.8	142.2
5.0	146.1
5.2	150.0
5.4	153.8
5.6	157.6
5.8	161.3
6.0	165.0
6.2	168.6
6.4	172.2
6.6	175.8
6.8	179.3
7.0	182.8
7.2	186.3
7.4	189.7
7.6	193.2
7.8	196.5

INSTALLATION OF INDOOR UNIT

The indoor unit of **Hydro Kit** is installed inside where terminal of under floor water pipe cycle and refrigerant pipe from the outdoor unit are accessible at the same time.

In this chapter conditions for installation place is described. In addition, considerations when installing accessories or 3rd party accessories are described, too.

Conditions where Indoor Unit is Installed

Specific conditions are required for installation place such as service space, wall mounting, water pipe length and height, total volume of water, adjusting expansion vessel, and water quality.

General Considerations

Followings are should be considered before the installation of the indoor unit.

- The installation place should be free from outdoor weather conditions such as rain, snow, wind, frost, etc.
- Choose the place where is water-resistant or good drainage.
- Service space should be secured.
- No flammable materials around the indoor unit.
- Mice can not be appeared to prevent entering the indoor unit or attacking wires.
- Do not place anything in front of the indoor unit to ensure air circulation around the indoor unit.
- Do not locate anything under the indoor unit to be free from unexpected water out.
- In case of water pressure increasing to 3 bar, water drainage should be treated when water is drained by safety valve.

Service Space

- Ensure that the spaces indicated by arrows around bottom, side, and top side.
- Wider spaces are preferred for easy maintenance and piping.
- If minimum service space is not secured, air circulation can be troubled and internal parts of the indoor unit can be damaged by overheating.

NOTE

- The default setting of the product is for heating only. To use the cooling system together, DIP S / W 4 should be turned ON and additional drain pan accessory should be installed.

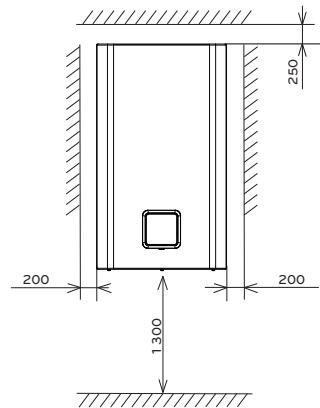

Minimum service space
(unit : mm)

Mounting to Wall

Step 1. Disconnect the remote control case from the front panel and disconnect the remote control cable.

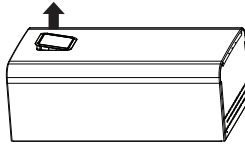

CAUTION

After installation is completed, return the remote control to its original state.

NOTE

Use a flat-blade screwdriver or a coin to remove the remote control case.

Step 2. After releasing five screws, detach front cover from the indoor unit. While detaching the front cover, grab the left and right sides of the front cover. Then pull into upward direction.

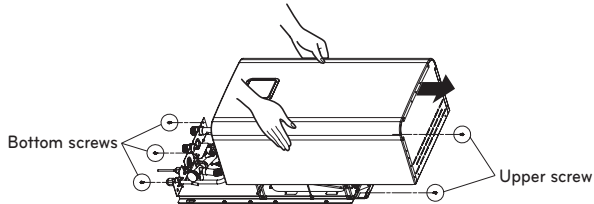

Step 3. Attach "Installation Sheet" to the wall and mark the location of bolts. This sheet helps to find correct location to the bolts.

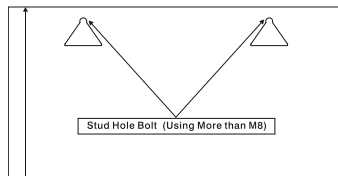

CAUTION

The sheet should be attached level. If not, the supporting plate and the indoor unit will not be mounted correctly.

- Step 4.** Detach the Installation sheet. Screw bolts at the hole marks on the wall.
When screwing bolts, use M8 ~ M11 anchor bolts to secure hanging the indoor unit.

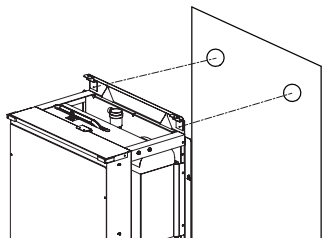
**NOTE**

Self drilling screw can be used as alternatives of M8 ~ M11 anchor bolts. But M8 ~ M11 anchor bolts are more preferred.

- Step 5.** Hang the indoor unit at the supporting plate.

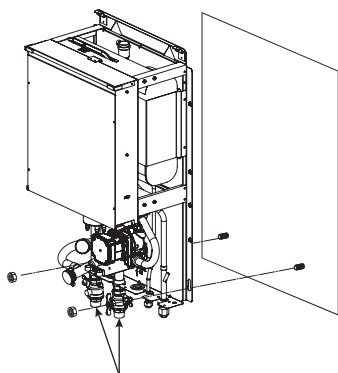

Shut-Off Valve : Field supply

PIPING AND WIRING FOR INDOOR UNIT

Procedures about water piping and electric wiring at the indoor unit are described in this chapter. Water piping and water circuit connection, water charging, pipe insulations will be shown for water piping procedures. For wiring, terminal block connection, connecting with the outdoor unit, electric heater wiring will be introduced. Accessories connection, such as sanitary water tank, thermostat, 3way or 2way valves, etc will be dealt in separated chapter.

Water Piping and Water Circuit Connection

CAUTION

General Considerations

Followings are should be considered before beginning water circuit connection.

- Service space should be secured.
- Water pipes and connections should be cleaned using water.
- Space for installing external water pump should be provided if internal water pump capacity is not enough for installation field.
- Never connect electric power while proceeding water charging.

Water Piping and Water Circuit Connection

Definition of terms are as follow :

- Water piping : Installing pipes where water is flowing inside the pipe.
- Water circuit connecting : Making connection between the product and water pipes or between pipes and pipes. Connecting valves or elbows are, for example, in this category.

While installing water pipes, followings should be considered :

- While inserting or putting water pipes, close the end of the pipe with pipe cap to avoid dust entering.
- When cutting or welding the pipe, always be careful that inner section of the pipe should not be defective. For example, no weldments or no burrs are found inside the pipe.
- Drain piping should be provided in case of water discharge by the operation of the safety valve. This situation can be happened when the internal pressure is over 3.0 bar and water inside the indoor unit will be discharged to drain hose.

While connecting water pipes, followings should be considered.

- Pipe fittings (e.g. L-shape elbow, T-shape tee, diameter reducer, etc) should be tightened strongly to be free from water leakage.
- Connected sections should be leakage-proof treatment by applying tefron tape, rubber bushing, sealant solution, etc.
- Appropriate tools and tooling methods should be applied to prevent mechanical breakage of the connections.
- Operation time of flow control valve(e.g. 3way valve or 2way valve) should be less than 90 seconds.
- Drain hose should be connected with drain piping.

 **WARNING****Installing shut-off valve**

- While assembling two shut-off valves, pop sound will be heard when valve is open or close by rotating handles. It is normal condition because the sound is due to leakage of charged nitrogen gas inside the valve. The nitrogen gas is applied to secure quality assurance.
- Before starting water charging, these two shut-off valves should be assembled with water inlet and outlet pipe of the indoor unit.
Shut-off valves : Field Supply

Water condensation on the floor

While cooling operation, it is very important to keep leaving water temperature higher than 16 °C. Otherwise, dew condensation can be occurred on the floor.

If floor is in humid environment, do not set leaving water temperature below 18 °C.

Water condensation on the radiator

While cooling operation, cold water may not flow to the radiator. If cold water enters to the radiator, dew generation on the surface of the radiator can be occurred.

Drainage treatment

While cooling operation, condensed dew can drop down to the bottom of the indoor unit. In this case, prepare drainage treatment (for example, vessel to contain condensed dew) to avoid water drop.

Water Charging

For water charging, please follow below procedures.

Step 1. Open all valves of whole water circuit. Supplied water should be charged not only inside the indoor unit, but also in the under floor water circuit, sanitary water tank circuit, FCU water circuit, and any other water circuits controlled by the product.

Step 2. Connect supply water into drain valve and fill valve.



CAUTION

No water-leakage permitted at the drain and fill valve. Leakage-proof treatment which is described in previous section should be applied.

* The configuration of the valve may vary by model type.

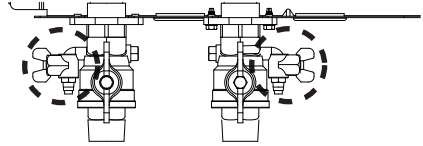

Water Out

Water In

Step 3. Start to supply water. While supplying water, following should be kept.

- Pressure of supplying water should be 2.0 bar approximately.
- For supplying water pressure, time to be taken from 0 bar to 2.0 bar should be more than 1 minute. Sudden water supply can yield water drain through safety valve.
- Fully open the cap of air vent to assure air purging. If air is exist inside the water circuit, then performance degrade, noise at the water pipe, mechanical damage at the surface of electric heater coil.

Step 4. Stop water supplying when the pressure gauge located in front of the control panel indicates 2.0 bar.

Step 5. Close drain valve and fill valve. Then wait for 20~30 seconds to observe water pressure being stabilized.

Step 6. If following conditions are satisfactory, then go to step 7(pipe insulation). Otherwise, go to step 3.

- Pressure gauge indicates 2.0 bar. Note that sometimes pressure is decreased after step 5 due to water charging inside expansion vessel.
- No air purging sound is heard or no water drop are popping out from air vent.

Pipe Insulation

Purpose of water pipe insulation is :

- To prevent heat loss to external environment
- To prevent dew generation on the surface of the pipe in cooling operation

Water pump Capacity

The water pump use variable type which is capable to change flow rate, so it may be required to change default water pump capacity in case of noise by water flow. In most case, however, it is strongly recommended to set capacity as Rated flow-rate.

NOTE

- To secure enough water flow rate, do not set water pump capacity as Minimum. It can lead unexpected flow rate error CH14.

Pressure Drop

NOTE

When installing the product, install additional pump in consideration of the pressure loss and pump performance.

If flow-rate is low, overloading of product can occur.

Capacity [kW]	Rated flow-rate [LPM]	Pump Head [m] (at rated flow-rate)	Product pressure drop [m] (Plate heat exchanger)	Serviceable Head [m]
5.6	25.9	6.1	0.4	5.7
7.1	20.1	7.3	0.3	7.0
9.0	15.8	7.5	0.2	7.3

MGQ62321902 : UPM3K GEO 20 - 75 CHBL
(5 kW, 7 kW, 9 kW)

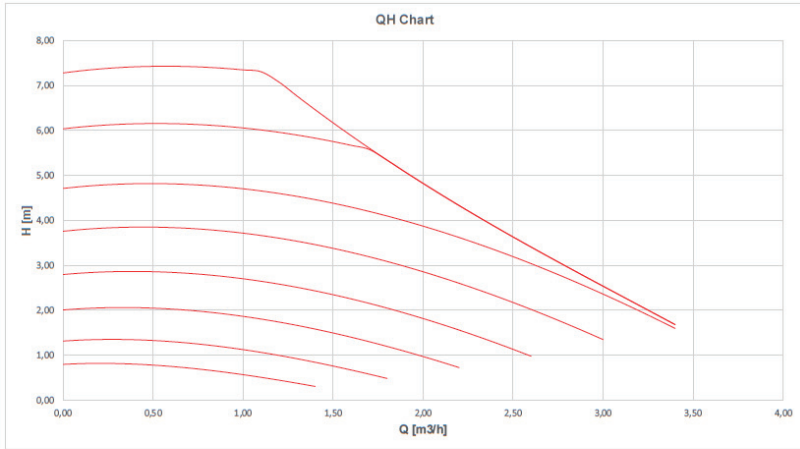

Performance test based on standard ISO 9906 with pre-pressure 2.0bar and liquid temperature 20 °C.



WARNING

Selecting a water flowrate outside the curves can cause damage to or malfunction of the unit.

Typical Installation Example

⚠ CAUTION

If **Hydro Kit** is installed with pre-existing boiler, the boiler and **Hydro Kit** should not be operated together. If entering water temperature of **Hydro Kit** is above 50 °C, the system will stop operation to prevent mechanical damage of the product. For detailed electric wiring and water piping, please contact authorized installer.
Some installation scenes are presented for example. As these scenes are conceptual figures, installer should optimize the installation scene according to the installation conditions.

CASE 1: Connecting Heat Emitters for Heating and Cooling

(Under floor loop, Fan Coil Unit, and Radiator)

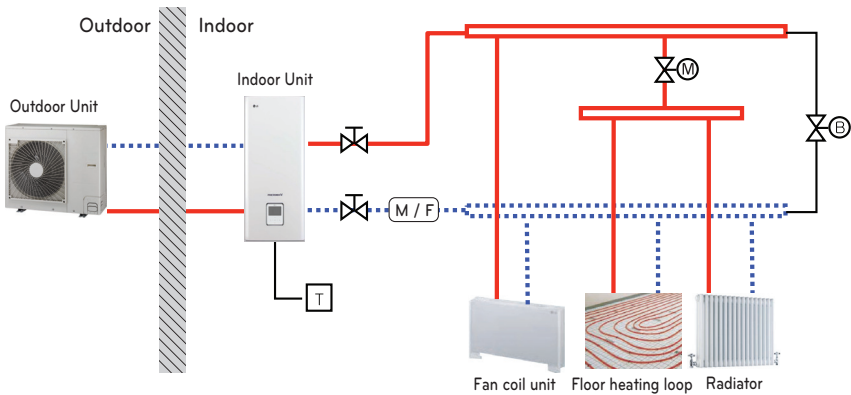

NOTE

- 2way valve
 - It is important to install 2way valve to prevent dew condensation on the floor and radiator while cooling mode.
 - 2way valve should be installed at the supply side of the collector.
- By-pass valve
 - To secure enough water flow rate, by-pass valve should be installed at the collector.
 - By-pass valve should guarantee minimum water flow rate in any case. Minimum water flow rate is described in water piping characteristics curve.

— High Temperature

..... Low Temperature

(M / F) Magnetic Filter (Recommended)



Room Thermostat(Field supply)



2way valve (Field supply)



Shut-off valve(Field supply)



By-pass valve(Field supply)

CASE 2: Connecting DHW Tank

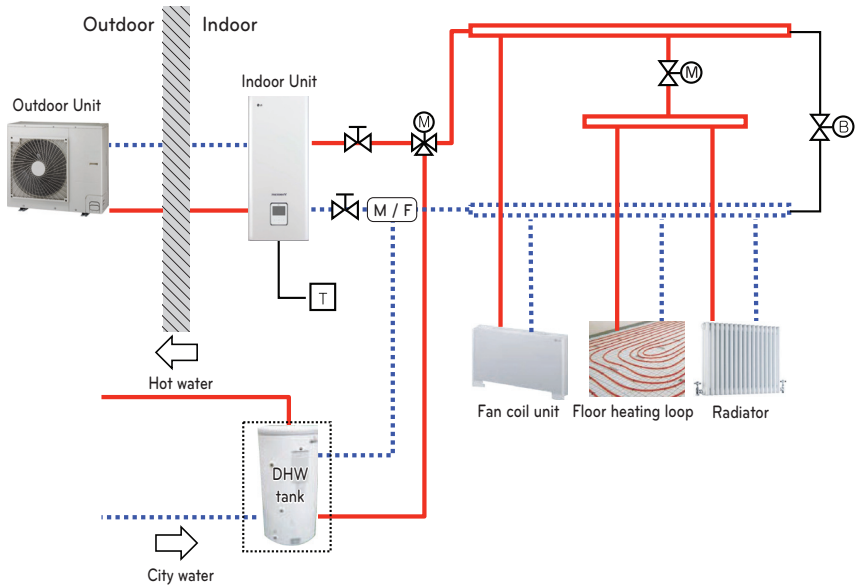

NOTE

- DHW tank
 - It should be equipped with internal electric heater to generate sufficient heat energy in very cold season.
 - DHW : Domestic Hot Water

— High Temperature

... Low Temperature

⊗ Shut-off valve(Field supply)

(M / F) Magnetic Filter (Recommended)

⊠ T Room Thermostat(Field supply)

⊗ M 2way valve
(Field supply)

⊗ B By-pass valve(Field supply)

⊗ M 3way valve
(Field supply)

CASE 3: Connecting Solar thermal system

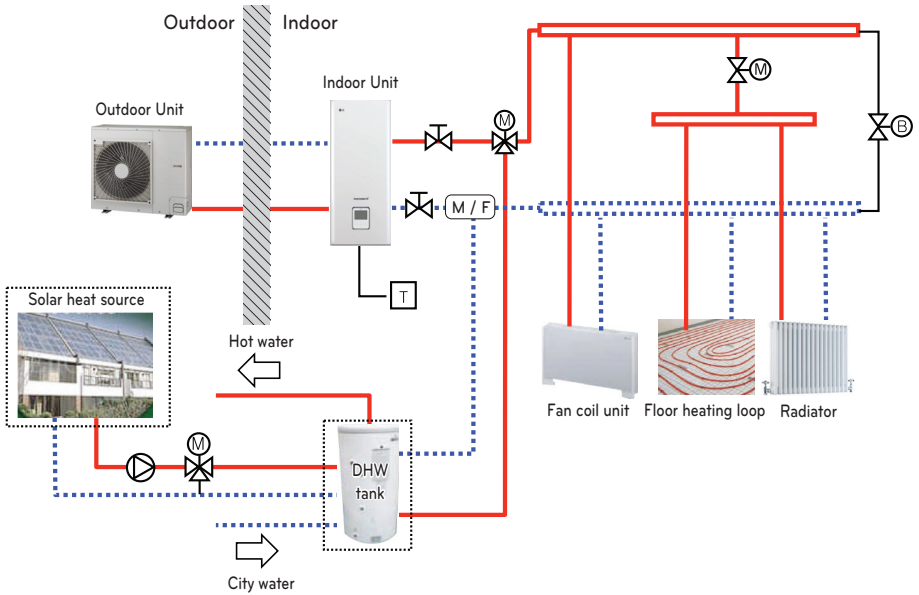

NOTE

- DHW tank
 - It should be equipped with internal electric heater to generate sufficient heat energy in very cold season.
 - DHW : Domestic Hot Water
- Pump
 - Maximum power consumption of pump should be less than 0.25 kW.

High Temperature	Room Thermostat(Field supply)	3way valve (Field supply)
Low Temperature	2way valve (Field supply)	Pump(Field supply)
Shut-off valve(Field supply)	By-pass valve(Field supply)	
Magnetic Filter (Recommended)		

Water cycle

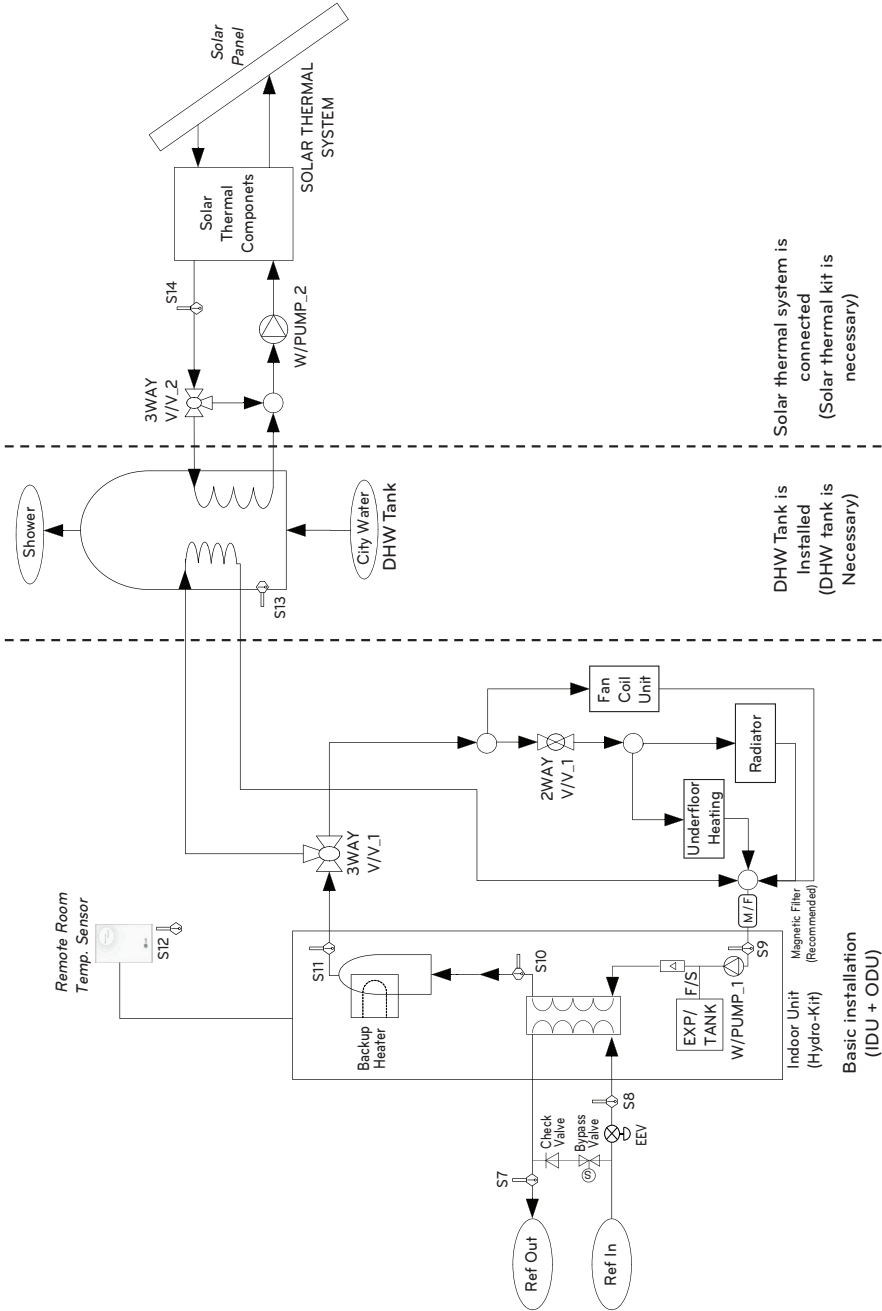

Description

Category	Symbol	Meaning	PCB Connector	Remarks
Indoor Unit	S7	Refrigerant temperature sensor (Gas side)	CN_PIPE_OUT	- Meaning is expressed based on Cooling mode.
	S8	Refrigerant temperature sensor (Liquid side)	CN_PIPE_IN	
	S9	Entering Water temperature sensor	CN_TH3	- S9, S10 and S11 are connected at 6 pin type connector CN_TH3.
	S10	Leaving Water temperature sensor		
	S11	Electric heater outlet temperature sensor		
	F/S	Flow Sensor	CN_F_METER	
	E/HT	Backup Heater	CN_E_HEAT_A CN_E_HEAT_B	- Heating capacity is divided into two level : partial capacity by E/HEAT(A) and full capacity by E/HEAT(A) + E/HEAT(B). - Operating power(230 V AC 50 Hz) of E/HEAT(A) and E/HEAT(B) are supplied by external power source via relay connector and ELB.
	W_PUMP1	Internal Water Pump	CN_MOTOR1 CN_W_PUMP_A	- Water Pump is connected at CN_MOTOR1 and CN_W_PUMP_A
	EXP/TANK	Expansion Tank	(no connector)	- Absorb volume change of heated water,
	S12	Remote Air temperature sensor	CN_ROOM	- Optional accessory (sold separately) - Model : PQRSTA0
CTR/PNL	Control Panel (or 'Remote Controller')	CN_REMO	- Pre built-in at indoor unit	
2WAY V/V_1	To control water flow for Fan Coil Unit	CN_2WAY_A	- 3 rd party accessory and Field installation (sold separately) - 2 wire NO or NC type 2way valve is supported.	
M / F	Magnetic Filter	(No connector)	- 3 rd party accessory and Field installation (sold separately) - It is strongly recommended to install an additional filter on the heating water circuit.	
Water Heating	W/TANK	DHW Tank	(No connector)	- 3 rd party accessory and Field installation (sold separately) - Generating and storing DHW by AWHP or built-in electric heater
	3WAY V/V_1	- Flow control for water which is leaving from indoor unit. - Flow direction switching between underfloor and water tank	CN_3WAY_A	- 3 rd party accessory and Field installation (sold separately) - SPDT type 3way valve is supported.
	CITY WATER	Water to be heated by Indoor unit and B/HT of W/TANK	(no connector)	- Field installation
	SHOWER	Water supplied to end-user	(no connector)	- Field installation
	S13	W/TANK water temperature sensor	CN_TH4	- S13 and S14 are connected at 4 pin type connector CN_TH4. - S13 is a part of DHW tank kit.(Model:PHLTA) - S14 is a part of solar thermal kit (Model:PHLLA)
S14	Solar-heated water temperature sensor			
Solar Heating	3WAY V/V_2	- Flow control for water which is heated and circulated by SOLAR THERMAL SYSTEM. - Flow direction switching between SOLAR THERMAL SYSTEM and W/TANK	CN_3WAY_B	- 3 rd party accessory and Field installation (sold separately) - SPDT type 3way valve is supported.
	W_PUMP/2	External Water Pump	CN_W_PUMP_B	- 3 rd party accessory and Field installation (sold separately) - If water pump of SOLAR THERMAL SYSTEM is incapable of circulation,external water pump can be used.
	SOLAR THERMAL SYSTEM	- This system can include following components : Solar panel, Sensors, Thermostats, Interim heat exchanger, Water pump, etc. - To utilized hot water heated by SOLAR THERMAL SYSTEM, end-user must install Solar-Kit accessory (PHLLA) provided by LG	(no connector)	- 3 rd party accessory and Field installation (sold separately)

Water Quality

Water quality should be complied with EN 98/83 EC Directives.
Detailed water quality condition can be found in EN 98/83 EC Directives.

CAUTION

- If the product is installed at existing hydraulic water loop, it is important to clean hydraulic pipes to remove sludge and scale.
- Installing sludge strainer in the water loop is very important to prevent performance degrade.
- Chemical treatment to prevent rust should be performed by installer.
- It is strongly recommended to install an additional filter on the heating water circuit. Especially to remove metallic particles from the heating piping, it is advised to use a magnetic or cyclone filter, which can remove small particles. Small particles may damage the unit and will NOT be removed by the standard filter of the heat pump system.

Frost protection

In areas of the country where entering water temperatures drop below 0 °C, the water pipe must be protected by using an approved antifreeze solution. Consult your AWHP unit supplier for locally approved solutions in your area. Calculate the approximate volume of water in the system. (Except the AWHP unit.) And add six liters to this total volume to allow for the water contained in AWHP unit.

Antifreeze type	Antifreeze mixing ratio					
	0 °C	-5 °C	-10 °C	-15 °C	-20 °C	-25 °C
Ethylene glycol	0 %	12 %	20 %	30 %	-	-
Propylene glycol	0 %	17 %	25 %	33 %	-	-
Methanol	0 %	6 %	12 %	16 %	24 %	30 %

If you use frost protection function, change DIP switch setting and input the temperature condition in Installation mode of remote controller. Refer to page 109 and 161.

CAUTION

- Use only one of the above antifreeze.
- If a antifreeze is used, pressure drop and capability degradation of the system can be occurred.
- If one of antifreezes is used, corrosion can be occurred. So please add corrosion inhibitor.
- Please check the concentration of the antifreeze periodically to keep same concentration.
- When the antifreeze is used (for installation or operation), take care to ensure that antifreeze must not be touched.
- Ensure to respect all laws and norms of your country about Anti-freeze usage.

Preparation for Piping

- Main cause of gas leakage is defect in flaring work. Carry out correct flaring work in the following procedure.
- Use the de-oxidised copper as piping materials to install.

Step 1. Cut the pipes and the cable.

- Use the accessory piping kit or the pipes purchased locally.
- Measure the distance between the indoor unit and the outdoor unit.
- Cut the pipes a little longer than measured distance.
- Cut the cable 1.5 m longer than the pipe length.

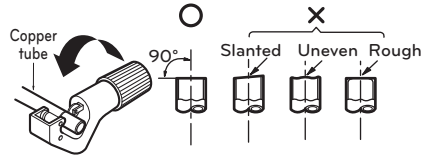

Step 2. Burrs removal

- Completely remove all burrs from the cut cross section of pipe/tube.
- Put the end of the copper tube/pipe to downward direction as you remove burrs in order to avoid to let burrs drop in the tubing.

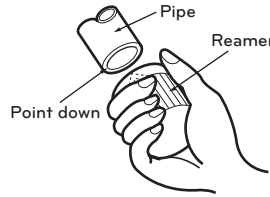

Step 3. Putting nut on

- Remove flare nuts attached to indoor and outdoor units, than put them on pipe/tube having completed burr removal. (Not possible to put them on after flaring work)

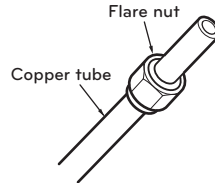

Step 4. Flaring work.

- Carry out flaring work using dedicated flaring tool for R-410A refrigerant as shown below.

Pipe diameter [inch(mm)]	A inch (mm)	
	Wing nut type	Clutch type
1/4 (6.35)	0.04~0.05(1.1~1.3)	0~0.02 (0~0.5)
3/8 (9.52)	0.06~0.07(1.5~1.7)	
1/2 (12.7)	0.06~0.07(1.6~1.8)	
5/8 (15.88)	0.06~0.07(1.6~1.8)	
3/4 (19.05)	0.07~0.08(1.9~2.1)	

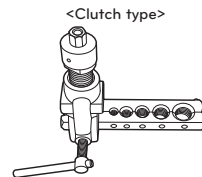
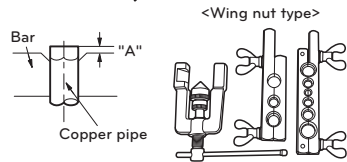

- Firmly hold copper tube in a bar(or die) as indicated dimension in the table above.

Step 5. Check

- Compare the flared work with right figure.
- If flare is seemed to be defective, cut off the flared section and do flaring work again.

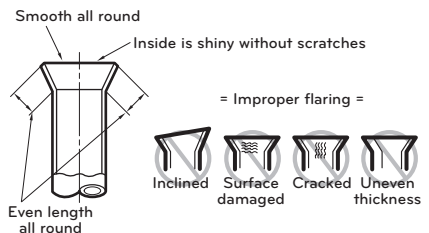

Electrical Wiring

General Consideration

Followings are should be considered before beginning indoor unit wiring.

- Field-supplied electrical components such as power switches, circuit breakers, wires, terminal boxes, etc should be properly chosen with compliance with national electrical legislation or regulation.
- Make it sure that supplied electricity is enough to operate the product including outdoor unit, electric heater, water tank heater, etc. The capacity of fuse also selected according to the power consumption.
- The main electricity supply should be dedicated line. Sharing main electricity supply with other devices such as washing machine or vacuum cleaner is not permitted.
- The installation of a residual current device (RCD) having a rated residual operating current not exceeding 30 mA is advisable.

⚠ CAUTION

- Before starting wiring job, the main electricity supply should be turned off until wiring is completed.
- When adjusting or changing wiring, the main electricity supply should be turned off and ground wire should be connected securely.
- Installation place should be free from the attack of wild animal. For example, mice's wire attacking or frog's entering into the indoor unit may cause critical electrical accident.
- All power connections should be protected from dew condensation by thermal insulation.
- All electrical wiring should comply with national or local electrical legislation or regulation.
- The ground should be connected exactly. Do not earth the product to the copper pipe, steel fence at the veranda, city water outlet pipe, or any other conductivity materials.
- Fix all cable using cord clamp tightly. (When cable is not fixed with cord clamp, use additionally supplied cable ties.)

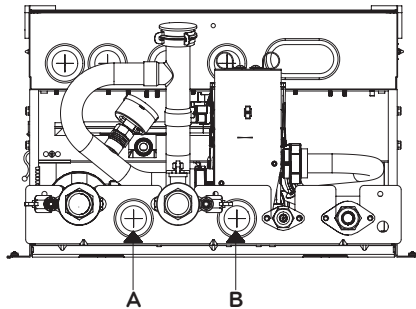

Hole A : for AC line (wire which is connected to the terminal block of the control box)

Hole B : for DC line (wire which is connected to the PCB of the control box)

Wiring Connection

Connect the wires to the terminals on the control board individually according to the outdoor unit connection.

- Ensure that the wire color of the outdoor unit and terminal No. are same as those of the indoor unit respectively.

Terminal Block 1

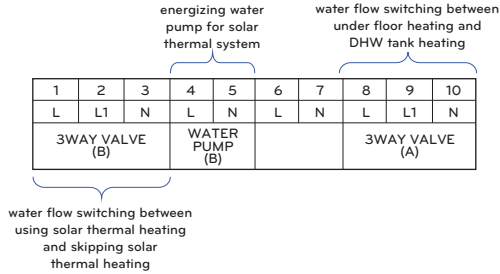

Terminal Block 2

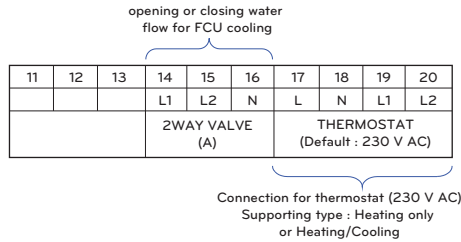

Terminal Block 3 (1Ø Electric Heater)

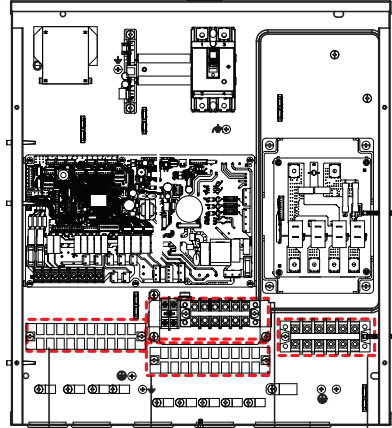
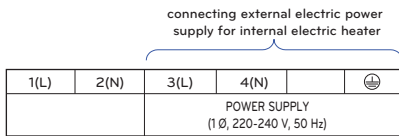

Terminal Block 1 Terminal Block 2 Terminal Block 4 & 5 Terminal Block 3

Terminal Block 4 & 5

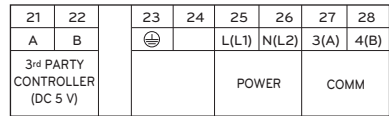

Connection for 3rd Party controller (5 V DC)

WARNING

Make sure that the screws of the terminal are free from looseness.

CAUTION

Be sure to test the power line and communication line for incorrect wiring before power is applied.

- 1) If the power line and communication line are swapped over, the product will be damaged.
- 2) Incorrect wiring confirmation test method : Measure the resistance across the power terminals (L,N) using a multi meter.
 - Resistance value of a normal connection: 1 mΩ or more
 - Incorrect wiring resistance value: 500 mΩ or less

Electric Heater Wiring

CAUTION

Power Cable Specification : The power cord connected to the outdoor unit should be complied with IEC 60245 or HD 22.4 S4(Rubber insulated cord, type 60245 IEC 66 or H07RN-F)

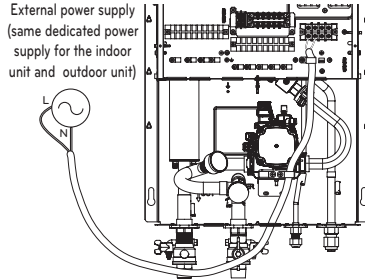
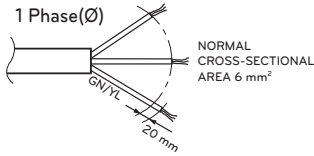

1Ø Electric Heater (For R32)

CAUTION

The power cord connected to the outdoor unit should be complied with IEC 60245 or HD 22.4 S4 (This equipment shall be provided with a cord set complying with the national regulation.)

The connecting cable connected to the outdoor unit should be complied with IEC 60245 or HD 22.4 S4 (This equipment shall be provided with a cord set complying with the national regulation.)

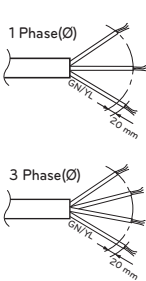

NORMAL CROSS-SECTIONAL AREA

Model Name		Area (mm ²)
Phase (Ø)	Capacity (kW)	
1	5	4
	7	
	9	
	12	
	14	
3	16	6
	12	
	14	
3	16	2.5
	16	

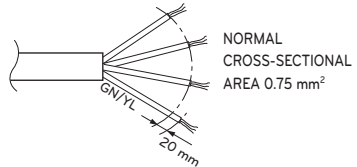

When the connection line between the indoor unit and outdoor unit is over 40 m, connect the telecommunication line and power line separately.

In order to avoid a hazard due to inadvertent resetting of the thermal cut-out, this appliance must not be supplied through an external switching device, such as a timer, or connected to a circuit that is regularly switched on and off by the utility.

If the supply cord is damaged, it must be replaced by the manufacturer, its service agent or similarly qualified persons in order to avoid a hazard.

CAUTION

After the confirmation of the above conditions, prepare the wiring as follows:

1. Use a separate power source only for the air conditioner.
For the method of wiring, follow the circuit diagram on the inner side of control box cover.
2. Install a circuit breaker between power source and the unit.
3. Make sure that wiring screws are fastened. Screw could be loose by vibration during transportation. (If screws are loose, wires could be burnt-out)
4. Check the Specification of power source
5. Make sure the electrical capacity is sufficient.
6. Starting voltage should be maintained above 90 percent of the rated voltage marked on the name plate.
7. Make sure the cable thickness matches the power sources specification.
(Please note the relation between cable length and thickness.)
8. Do not install the earth leakage breaker in a place which is wet or moist.
Water or moisture may cause a short circuit.
9. The following troubles could be caused by voltage drop-down.
 - Vibration of a magnetic switch, damage on the contact point there of, (fuse breaking), disturbance to the normal function of a an overload protection device.
 - Proper starting power is not given to the compressor.
10. Before supplying power to the indoor unit, please check the wiring of the power and communication lines.
11. If the supply cord is damaged, it must be replaced by the manufacturer, its service agent or similarly qualified persons in order to avoid a hazard.

Rating of circuit breakers

	The thickness of Minimum wire (mm ²)		Leakage circuit breaker
	Main power wire	Ground wire	
1 Unit	2.5 ~ 6	2.5	< 30 ~ 50 A 100 mA 0.1 S
2 Unit	10 ~ 16	2.5	< 75 ~ 100 A 100 mA 0.1 S
3 Unit	25 ~ 35	4	< 125 ~ 150 A 100 mA 0.1 S
4 Unit	70	6	< 175 ~ 200 A 100 mA 0.1 S

Connecting Cables

Types of the cables

Classification	Types	Cables cross section
Power cable(CV)	mm ² x cores	4.0 x 3
Power cable(H07RN-F)	mm ² x cores	1.5 x 3
Communication cable(VCTF-SB)	mm ² x cores	1.0~1.5 x 2

The distance between communication cable and power cable

- If the power cable and communication cable are tied together, system malfunction may occur with electrostatic, electromagnetic combination effect causing the interference signal. If communication cable is connected along with power cable, secure at least 50 mm distance between indoor unit power cable and communication cable.

It is the value with the assumption of the length of the parallel cable as 100 m. If it is longer than 100 m, it shall be calculated again with proportional to the added length.

If the distortion in the waveform of the power still occurs despite securing the distance, increase the distance.

※ When several power cables are inserted into the transmission line, or tied together, make sure to consider the following issues.

- Power cables and communication cable shall not be in the same transmission line.
- Power cables and communication cable shall not be tied together.



WARNING

- Are all of the indoor units and outdoor units grounded?
- If grounding is not properly done, there is a risk of electric shock. Grounding must be done by a qualified technician.
- Consider the surrounding conditions(surrounding temperature, direct sunlight, rain water, etc.) when wiring the cable.
- The thickness of the power cable is the minimum thickness of metal conductor cable. Use thicker cable considering the voltage drop.

ACCESSORIES INSTALLATION

Hydro Kit can interface to various accessories to extend its functionality and to improve user convenience. In this chapter, specifications about supported 3rd party accessories and how to connect to **Hydro Kit** is introduced.

It is noted that this chapter only deal with 3rd party accessories. For accessories supported by LG Electronics, please refer to installation manual of each accessories.

CAUTION

- Install the drain pan when cooling.
- If not installed, water may form.
- Please refer to separate installation manual when installing drain pan.

Before Installation

WARNING

Followings should be kept before installation

- Main power must be turned off during installing 3rd party accessories.
- 3rd party accessories should be comply with supported specification.
- Proper tools should be chosen for installation.
- Never do installation with wet hands.

Thermostat

Thermostat is generally used to control the product by air temperature. When thermostat is connected to the product, the product operation is controlled by the thermostat.

Installation condition

CAUTION

- USE 220-240 V~ Thermostat
- Some electro-mechanical type thermostat has internal delay time to protect compressor. In that case, mode change can takes time more than user's expectation. Please read thermostat manual carefully if the unit does not response quickly.
- Setting temperature range by thermostat can be different with that of the unit. The heating or cooling set temperature should be chosen within the setting temperature range of the unit.
- It is highly recommended that the thermostat should be installed where space heating is mainly applied.

Following location should be avoid to secure proper operation :

- Height from floor is approximately 1.5 m.
- Thermostat can not be located where the area may be hidden when door is open.
- Thermostat can not be located where external thermal influence may be applied. (such as above heating radiator or open window)

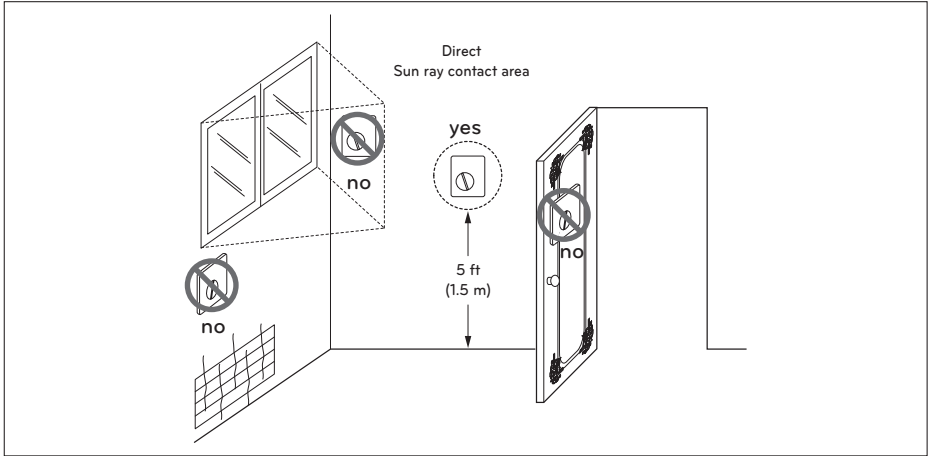

Thermostat

General Information

The Heat Pump supports following thermostats.

Type	Power	Operating Mode	Supported
Mechanical (1)	230 V~	Heating Only (3)	Yes
		Heating / Cooling (4)	Yes
Electrical (2)	230 V~	Heating Only (3)	Yes
		Heating / Cooling (4)	Yes

- (1) There is no electric circuit inside the thermostat and electric power supply to the thermostat is not required.
- (2) Electric circuit such as display, LED, buzzer, etc is included in the thermostat and electric power supply is required.
- (3) Thermostat generates "Heating ON or Heating OFF" signal according to user's heating target temperature.
- (4) Thermostat generates both "Heating ON or Heating OFF" and "Cooling ON or Cooling OFF" signal according to user's heating and cooling target temperature.

⚠ CAUTION

Choosing heating / cooling thermostat

- Heating / cooling thermostat must have "Mode Selection" feature to distinguish operation mode.
- Heating / cooling thermostat must be able to assign heating target temperature and cooling target temperature differently.
- If above conditions are not kept, the unit can not operation properly.
- Heating / cooling thermostat must send cooling or heating signal immediately when temperature condition is satisfied. No delay time while sending cooling or heating signal is permitted.

How to wire thermostat

Follow below procedures Step 1 ~ Step 5.

Step 1. Uncover front cover of the unit and open the control box.

Step 2. Identify the power specification of the thermostat. If it is 220-240 V~, go to Step 3.

Step 3. If it is Heating only thermostat, go to step 4. Otherwise, if it is Heating / cooling thermostat, go to step 5.

Step 4. Find terminal block and connect wire as below.

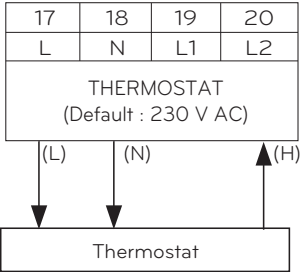

! WARNING

Mechanical type thermostat.

Do not connect wire (N) as mechanical type thermostat does not require electric power supply.

! CAUTION

Do not connect external electric loads.

Wire (L) and (N) should be used only for operation electric type thermostat.

Never connect external electric loads such as valves, fan coil units, etc. If connected, Main PCB (Heater) can be seriously damaged.

(L) : Live signal from PCB to thermostat

(N) : Neutral signal from PCB to thermostat

(H) : Heating signal from thermostat to PCB

Step 5. Find terminal block and connect wire as below.

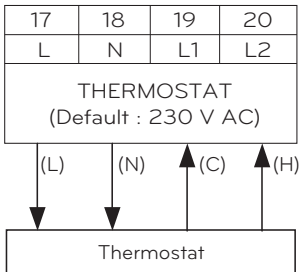

! WARNING

Mechanical type thermostat.

Do not connect wire (N) as mechanical type thermostat does not require electric power supply.

! CAUTION

Do not connect external electric loads.

Wire (L) and (N) should be used only for operation Electric type thermostat.

Never connect external electric loads such as valves, fan coil units, etc. If connected, Main PCB (Heater) can be seriously damaged.

(L) : Live signal from PCB to thermostat

(N) : Neutral signal from PCB to thermostat

(C) : Cooling signal from thermostat to PCB

(H) : Heating signal from thermostat to PCB

Final check

- DIP switch setting :
Set DIP switch No. 8 to 'ON'. Otherwise, the unit can not recognize the thermostat.
- Remote Controller :
 - 'Thermostat' text is displayed on the remote controller.
 - Button input is prohibited.

DHW Tank

To establish DHW circuit, 3way valve and DHW tank kit is required. If solar thermal system is pre-installed at the installation field, solar thermal kit is required to interface solar thermal system – to – DHW tank – to – **Hydro Kit**

Installation condition

Installing sanitary water tank requires following considerations :

- Sanitary water tank should be located at the flat place.
- Water quality should be complied with EN 98/83 EC directives.
- As this water tank is sanitary water tank (indirect heat exchange), do not use anti water-freezing treatment like ethylene glycol.
- It is highly recommend to wash out inside of the sanitary water tank after installation. It ensures generating clean hot water.
- Near the sanitary water tank there should be water supply and water drain to easy access and maintenance.
- Set the maximum value of the temperature control device of sanitary tank.

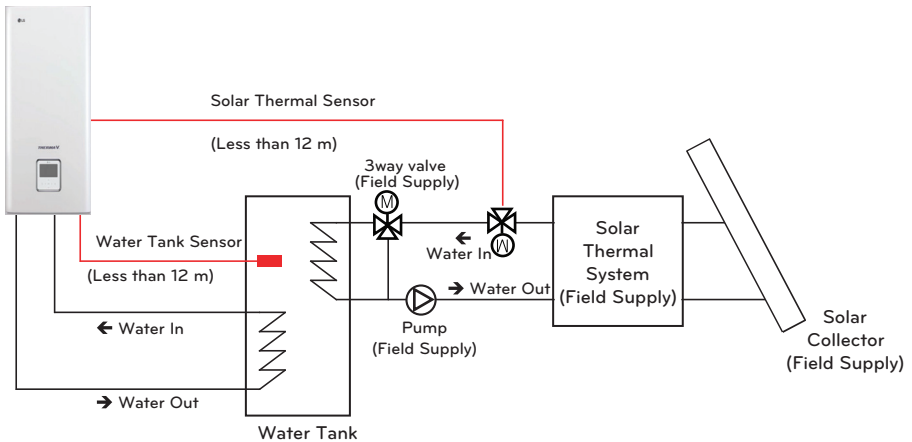

General Information

Hydro Kit supports following 3way valve.

Type	Power	Operating Mode	Supported
SPDT 3-wire (1)	230 V AC	Selecting "Flow A" between "Flow A" and "Flow B" (2)	Yes
		Selecting "Flow B" between "Flow A" and "Flow B" (3)	Yes

(1) : SPDT = Single Pole Double Throw. Three wires consist of Live1 (for selecting Flow A), Live 2 (for selecting Flow B), and Neutral (for common).

(2) : 'Flow A' means water flow from the unit to under floor water circuit.

(3) : 'Flow B' means water flow from the unit to DHW tank.

⚠ WARNING

Installing recirculation pump

When **Hydro Kit** is used with DHW tank, it is **STRONGLY** recommended to install recirculation pump to prevent flooding out cold water at the end of hot water supply and to stabilize the water temperature inside DHW tank

- The recirculation pump should be operated when DHW demand is not required. Therefore, external time scheduler to determine when the recirculation pump should turn on and turn off is required.

- The operating duration time of the recirculation pump is calculated as follow :

Duration time [minute] = $k \times V \times R$

k : 1.2 ~ 1.5 is recommended. (If distance between pump and tank is far, then choose high number)

V : Volume of sanitary water tank [liter]

R : Water flow rate of pump [liter per minute], which is determined by pump performance curve.

- The pump operating start time should be prior to the sanitary water demand.

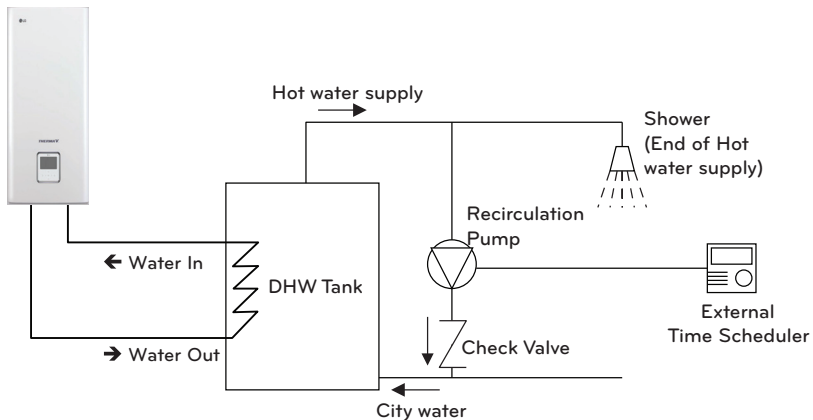

How to Wire DHW Tank Heater

Step 1. Uncover heater cover of the DHW tank. It is located side of the tank.

Step 2. Find terminal block and connect wires as below. Wires are field-supplied item.

(L) : Live signal from PCB to Heater.

(N) : Neutral signal from PCB to Heater.

! WARNING

Wire specification

- Cross-sectional area of the wire should be 6 mm².

Adjusting thermostat temperature

- To guarantee proper operation, it is recommended to set temperature of thermostat to maximum temperature (symbol at the picture).

- 1Ø Electric Heater Model and 3Ø Electric Heater Model are set by same method as below.

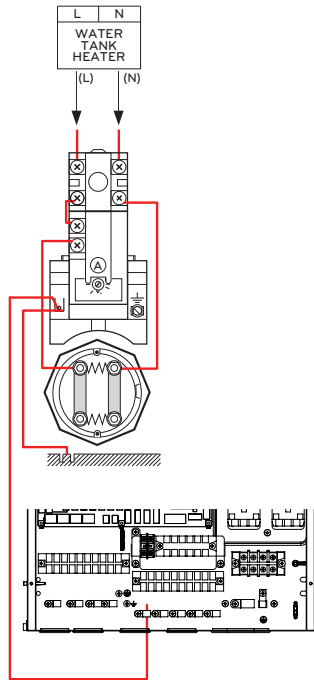

Solar Thermal Kit

This product can be used by connecting the solar thermal kit in the field. It can be utilized hot water heated by solar thermal system. End-user must be LG AWHP solar thermal kit.

How to Install Solar Thermal Kit

[Parts of Solar Thermal Kit]



Holder sensor

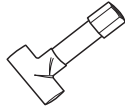

Tube Connector



Solar Thermal Sensor
12 m(1 EA)

Follow below procedures step 1 ~ step 4.

Step 1. Install tube connector(it is necessary to reduce or extend diameter of pipe.) the pipe and solar thermal kit.

Step 2. Check if the power of the unit is turned off.

Step 3. Disassemble front panels and distinguish control box(Indoor) of the unit.

Step 4. Insert harness into PCB(CN_TH4) fully and fix the thermal sensor into tube connector as shown below.

* If the DHW tank sensor is connected, disconnect the sensor from PCB first.

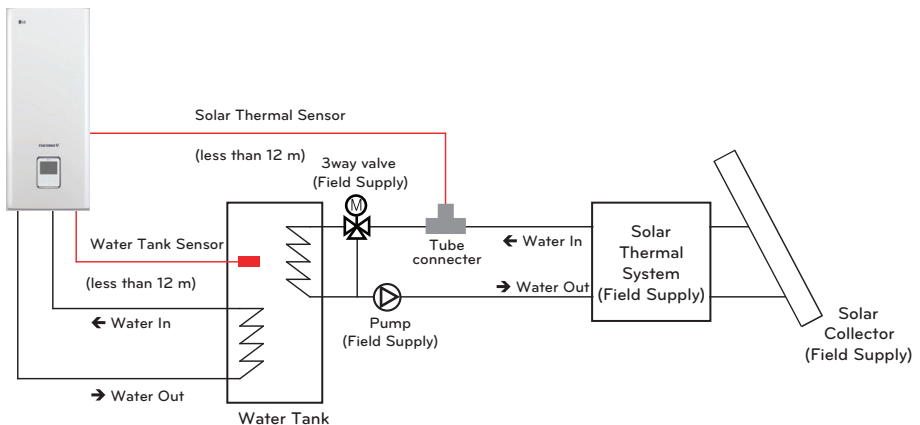
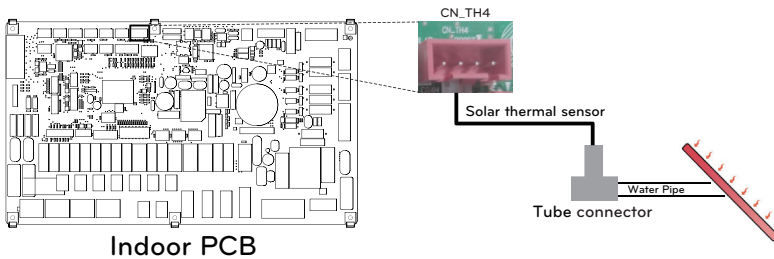

Dry Contact

Dry Contact is a solution for automatic control of HVAC system at the owner's best. In simple words, it's a switch which can be used to turn the unit On/Off after getting the signal from external sources.

How to install dry contact

[Parts of Dry contact]

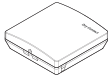

Dry Contact body



Cable(for connecting with IDU)

Follow below procedures step 1 ~ step 4.

Step 1. Check if the power of the unit is turned off.

Step 2. Disassemble front panels and distinguish terminal block in Indoor PCB.

Step 3. Connect cable to the unit PCB(CN_CC) fully.

Step 4. Then, Insert harness to the dry contact PCB(CN_INDOOR) firmly as shown below.

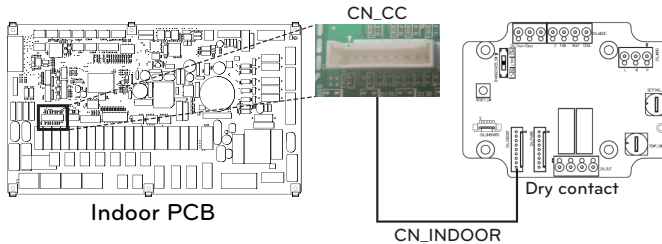

NOTE

- For more information about installing Dry Contact, Please refer installation manual provided with Dry Contact.
- For system set-up, please read chapter 8.(Especially function code No.6)

[Setting of Contact Signal Input]

- For input contact closure only(No power input)

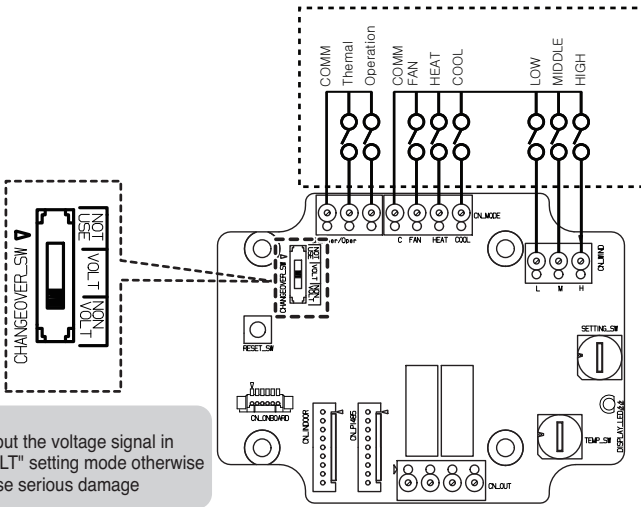

Thermostat
LG does not supply this section (Field supply)

Notes

Do not input the voltage signal in "NON VOLT" setting mode otherwise it will cause serious damage

- For input contact voltage : DC 12 V, 24 V~

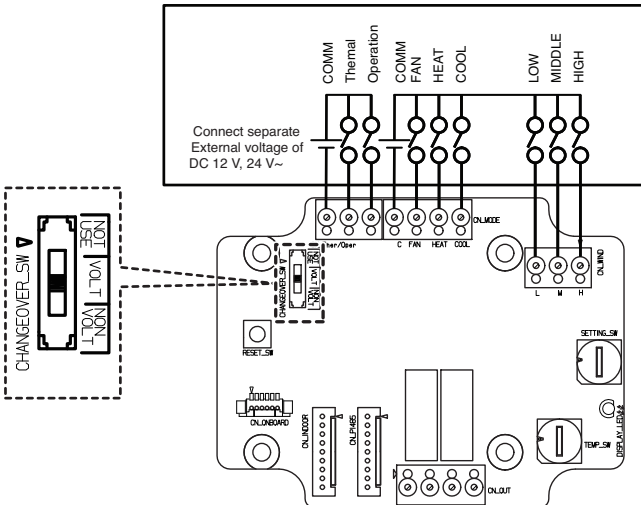

Thermostat
LG does not supply this section (Field supply)

External Controller - Setting up programmable digital input operation

If you require to operate control depending on external digital input(ON/OFF), connect cable to indoor PCB(CN_EXT).

Follow below procedures step 1 ~ step 4.

Step 1. Check if the power of the unit is turned off.

Step 2. Disassemble front panels and distinguish control box(Indoor) of the unit

Step 3. Connect the external controller to PCB(CN_EXT) completely.

Step 4. Connect the cable and field installation part.

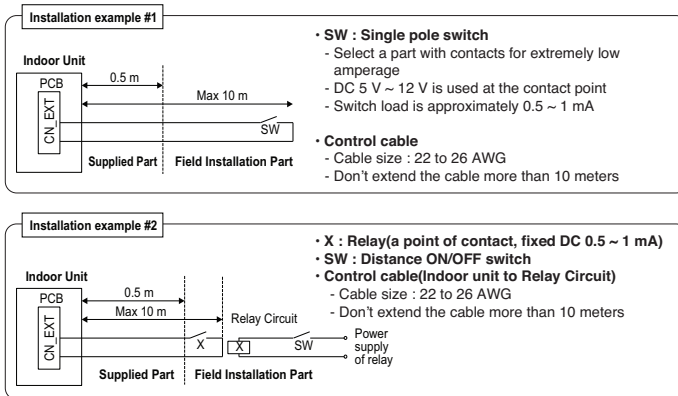
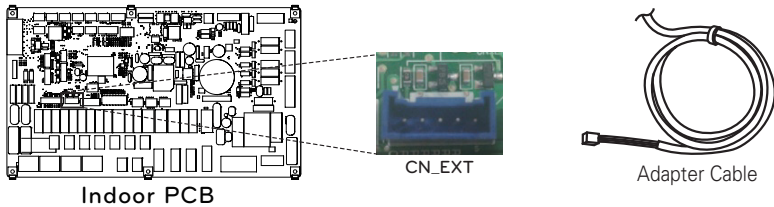

Determining the purpose of CN_EXT

Setting value: 0 ~ 5 step Indoor CN-EXT port setting

- 0: default
- 1: Simple operation on / off
- 2: Dry contact (simple contact)
- 3: Emergency stop only for indoor unit
- 4: Reattachment / absence
- 5: Emergency stop of all indoor units (It can be set only when indoor unit has emergency stop function)

Remote Temperature Sensor

Remote temperature sensor can be installed any place a user wants to detect the temperature.

- The function is not available for some products.

Installation condition

Role and constraint while installation of remote air temperature sensor is very similar to that of thermostat.

- Distance between the unit and the remote air temperature sensor should be less than 15 m due to length of the connection cable of remote air temperature sensor.
- For other constraints, please refer to previous page where constraints about thermostat is described.

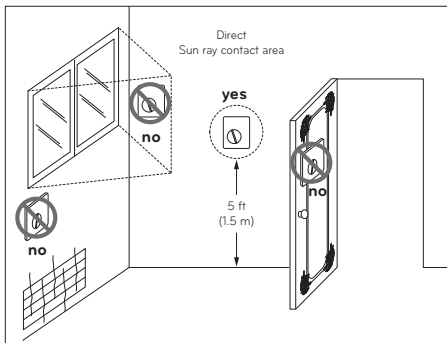

Thermostat

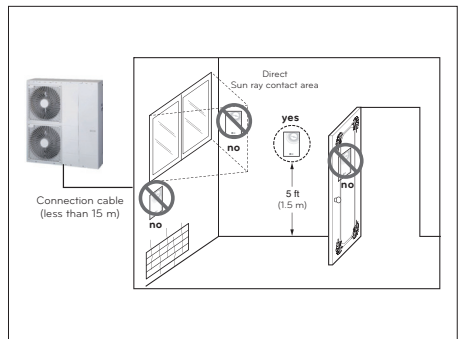

Remote Air Temperature Sensor

How to Install Remote Temperature Sensor

[Parts of Remote Temperature Sensor]



Sensor



Screw(to fix remote sensor)

Follow below procedures step 1 ~ step 5.

Step 1. Decide where the remote temperature sensor is installed. Then, Determine the location and height of the fixing screws in fig. 1 (Interval between the screws : 60 mm)

Step 2. Check if the power of the unit is turned off.

Step 3. Disassemble front panels and distinguish control box(Indoor) of the unit.

Step 4. Insert temperature sensor into PCB(CN_ROOM) and fix the sensor firmly in fig. 2.

Step 5. The Connection wire does not matter if you change the color of the wire because of nonpolar.

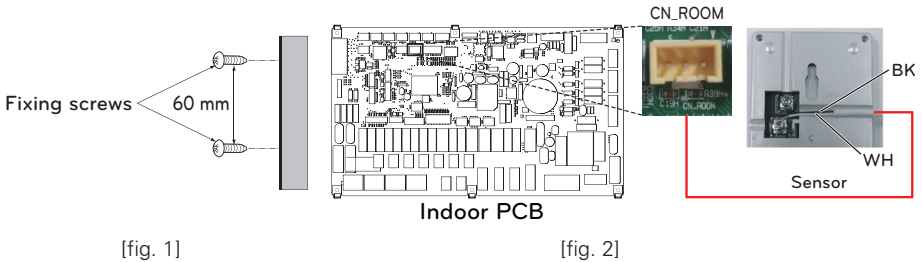

Step 6. Integrate the remote temperature sensor with the screws as the order of arrows.

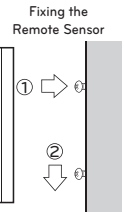

CAUTION

- Choose the place where the average temperature can be measured for the unit operates.
- Avoid direct sunlight.
- Choose the place where the cooling/heating devices do not affect the remote sensor.
- Choose the place where the outlet of the cooling fan do not affect the remote sensor.
- Choose the place where the remote sensor isn't affected when door is open.

NOTE

- For more information about installing Remote Temperature Sensor, Please refer installation manual provided with Remote Temperature Sensor.
- For system set-up, please read chapter 8. (Especially function code No.3)

Solar pump

Solar pump can be required to energize water flow when solar thermal system is installed.

How to install solar pump

Follow below procedures step 1 ~ step 4.

Step 1. Check if the power of the unit is turned off.

Step 2. Disassemble front panels and distinguish control box(Indoor) of the unit.

Step 3. Check if the harness(Black) is inserted fully to the indoor unit PCB (CN_W_PUMP_B).

Step 4. Connect the external pump to terminal block 1(4/5).

※ It is possible to un-use solar pump depending on installation environment.

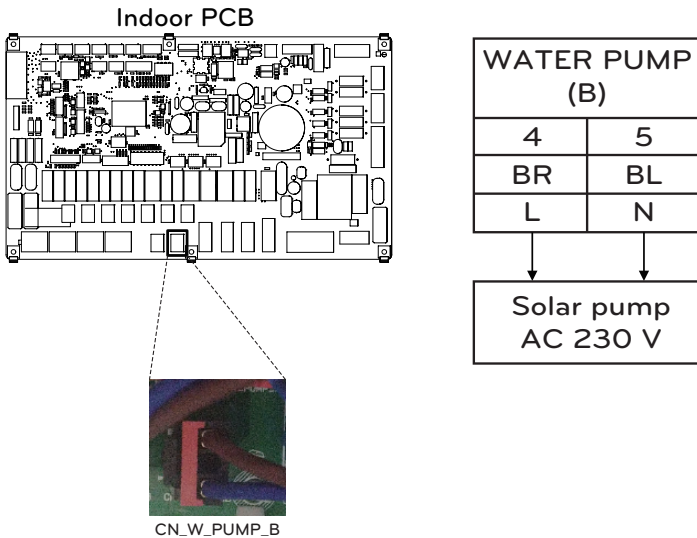

Wi-fi Modem

Wi-fi modem enables remote system operation from smartphone. Available functions include selection of on/off, operation mode, DHW heating, temperature setup and weekly scheduling etc.

How to install Wi-fi Modem

[Parts of Wi-fi modem]



Wi-fi modem body

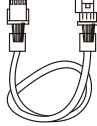

USB Cable

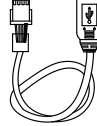

Extension Cable

Follow below procedures step 1 ~ step 5.

Step 1. Check if the power of the unit is turned off.

Step 2. Disassemble front panels and distinguish control box(Indoor) of the unit.

Step 3. Connect the USB cable to the indoor unit PCB (CN_WF ; Blue) until it clicks into place.

Step 4. Connect the Wi-Fi modem to the USB cable fully.

Step 5. Refer to the image below to install the Wi-Fi modem in the marked position.

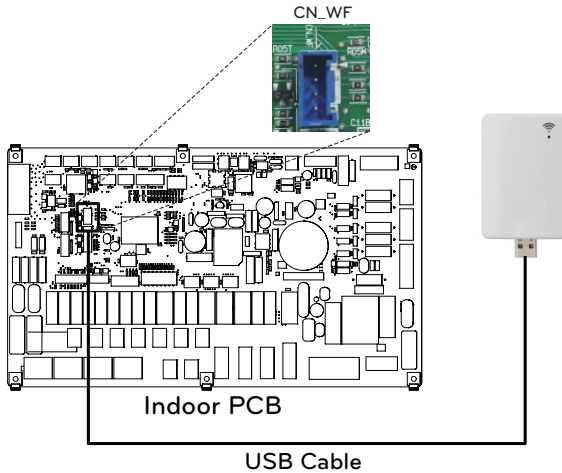

2Way Valve

2way valve is required to control water flow while cooling operation. Role of 2way valve is to cut off water flow into under floor loop in cooling mode when fan coil unit is equipped for cooling operation.

General Information

Hydro Kit supports following 2way valve.

Type	Power	Operating Mode	Supported
NO 2-wire (1)	230 V AC	Closing water flow	Yes
		Opening water flow	Yes
NC 2-wire (2)	230 V AC	Closing water flow	Yes
		Opening water flow	Yes

(1) : Normal Open type. When electric power is NOT supplied, the valve is open. (When electric power is supplied, the valve is closed.)

(2) : Normal Closed type. When electric power is NOT supplied, the valve is closed. (When electric power is supplied, the valve is open.)

How to Wire 2Way Valve

Follow below procedures Step 1 ~ Step 2.

Step 1. Uncover front cover of the unit.

Step 2. Find terminal block and connect wire as below.

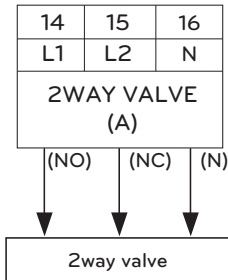

CAUTION

Dew Condensation

- Wrong wiring can yield dew condensation on the floor. If radiator is connected at the under floor water loop, dew condensation can be occurred on the surface of the radiator.

WARNING

Wiring

- Normal Open type should be connected to wire (NO) and wire (N) for valve opening in cooling mode.
- Normal closed type should be connected to wire (NC) and wire (N) for valve closing in cooling mode.

(NO) : Live signal (for Normal Open type) from PCB to 2way valve.

(NC) : Live signal (for Normal Closed type) from PCB to 2way valve.

(N) : Neutral signal from PCB to 2way valve.

Final Check

- Flow direction :
 - Water should not flow into under floor loop in cooling mode.
 - To verify the flow direction, check temperature at the water inlet of the under floor loop.
 - If correctly wired, this temperatures should not be approached to 6 °C in cooling mode.

3Way Valve(A)

3Way Valve(A) is required to operate DHW water tank. Role of 3way valve is flow switching between under floor heating loop and water tank heating loop. Plus, it is required to operate 3rd party boiler.

General Information

Hydro Kit supports following 3way valve.

Type	Power	Operating Mode	Supported
SPDT 3-wire (1)	220-240 V~	Selecting "Flow A" between "Flow A" and "Flow B" (2)	Yes
		Selecting "Flow B" between "Flow A" and "Flow B" (3)	Yes

(1) : SPDT = Single Pole Double Throw. Three wires consist of Live1 (for selecting Flow A), Live 2 (for selecting Flow B), and Neutral (for common).

(2) : Flow A means 'water flow from the unit to under floor water circuit.'

(3) : Flow B means 'water flow from the unit to DHW water tank.'

How to wire 3way valve(A)

Follow below procedures Step 1 ~ Step 2.

Step 1. Uncover front cover of the unit.

Step 2. Find terminal block and connect wire as below.

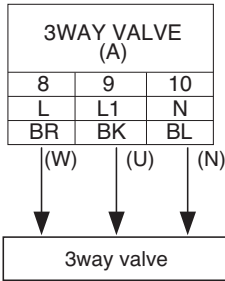

WARNING

- 3way valve should select water tank loop when electric power is supplied to wire (W) and wire (N).
- 3way valve should select under floor loop when electric power is supplied to wire (U) and wire (N).

(W) : Live signal (Water tank heating) from PCB to 3way valve

(U) : Live signal (Under floor heating) from PCB to 3way valve

(N) : Neutral signal from PCB to 3way valve

3Way Valve(B)

3way valve(B) is required to operate Solar thermal system. Role of 3way valve is flow switching between open and close mode of the solar circuit.

General Information

Hydro Kit supports following 3way valve.

Type	Power	Operating Mode	Supported
SPDT 3-wire (1)	220-240 V~	Selecting "Flow A" between "Flow A" and "Flow B" (2)	Yes
		Selecting "Flow B" between "Flow A" and "Flow B" (3)	Yes

(1) : SPDT = Single Pole Double Throw. Three wires consist of Live1 (for selecting Flow A), Live 2(for selecting Flow B), and Neutral (for common).

(2) : Flow B means 'heat source toward solar panel repeatedly'. (close mode of circuit)

(3) : Flow A means 'heat source flow from solar panel to DHW tank in solar circuit'.
(open mode of circuit)

How to wire 3way valve(B)

Follow below procedures Step 1 ~ Step 2.

Step 1. Uncover front cover of the unit.

Step 2. Find terminal block and connect wire as below.

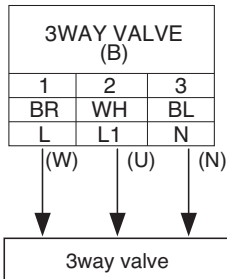

WARNING

- 3way valve should select "close solar circuit" when electric power is supplied to wire (W) and wire (N).
- 3way valve should select "open solar circuit" when electric power is supplied to wire (U) and wire (N).

(W) : Live signal (close solar circuit) from PCB to 3way valve

(U) : Live signal (open solar circuit) from PCB to 3way valve

(N) : Neutral signal from PCB to 3way valve

Final check

No.	Check point	Description
1	Connection of Water Inlet/Outlet	<ul style="list-style-type: none"> - Check if the shut-off valves should be assembled with Water inlet and outlet pipe of the unit - Check the location of the water inlet/outlet water pipe
2	Hydraulic pressure	<ul style="list-style-type: none"> - Check the pressure of supplying water by using pressure gauge inside the unit - Pressure of Supplying water should be Under 3.0 bar approximately
3	Water pump capacity	<ul style="list-style-type: none"> - To secure enough water flow rate, do not set water pump capacity as Minimum. - It can lead unexpected flow rate error CH14.
4	Transmission line and power source wiring	<ul style="list-style-type: none"> - Check if Transmission line and power source wiring are separated from each other. - If it is not, electronic noise may occur from the power source.
5	The power cord specifications	<ul style="list-style-type: none"> - Check the power cord specifications
6	3Way Valve	<ul style="list-style-type: none"> - Water should flow from Water outlet of the unit to sanitary tank Water inlet when sanitary tank heating is selected. - To verify the flow direction, Make sure that the water outlet temperature of the unit and water inlet temperature of sanitary Water tank are similar
7	2Way Valve	<ul style="list-style-type: none"> - Water should not flow into under floor loop in cooling mode. - To verify the flow direction, check temperature at the water inlet of the under floor loop. - If correctly wired, this temperatures should not be approached to 6 °C in cooling mode.
8	Air Vent	<ul style="list-style-type: none"> - Air-vent must be located highest level of Water pipe system - It should be installed at the point which is easy to service. - It takes some times to remove air in the water system if air purge is not performed sufficiently it may occur CH14 error.

SYSTEM SET-UP

As **Hydro Kit** is designed to satisfy various installation environment, it is important to set up system correctly. If not configured correctly, improper operation or degrade of performance can be expected.

DIP Switch Setting

⚠ CAUTION

Turn off electric power supply before setting DIP switch

- Whenever adjusting DIP switch, turn off electric power supply to avoid electric shock.





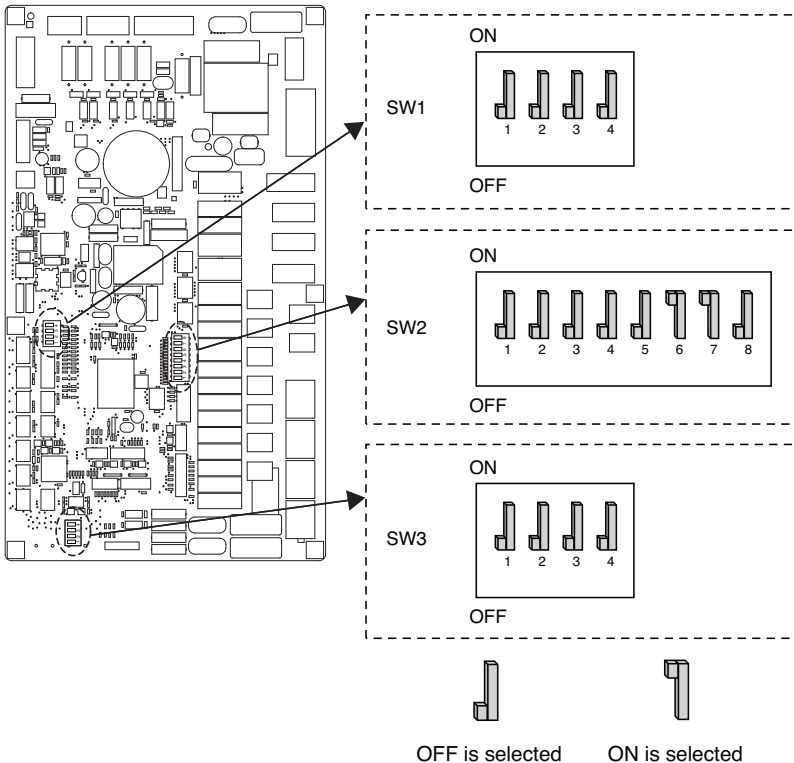























General Information

Indoor PCB















DIP Switch Information

Option Switch 2

Description	Setting	Default	
Role when central controller is equipped	1 	1 	
	1 		As Slave
Accessory installation information	  2 3	 	
	  2 3		Unit + Outdoor unit + DHW tank is installed
	  2 3		Unit + Outdoor unit + DHW tank + Solar thermal system is installed
	  2 3		Reserved
Cycle	4 	4 	
	4 		Heating & Cooling
Selecting electric heater capacity	  6 7	 	
	  6 7		1Ø model : Half capacity is used 3Ø model : 1/3 capacity is used
	  6 7		Reserved
	  6 7		Full capacity is used
Thermostat installation information	8 	8 	
	8 		Thermostat is installed

Option Switch 3

Description	Setting	Default
Remote Air Sensor	1  Remote sensor is not installed	1 
	1  Remote sensor is installed	
ANTIFREEZE	2  Antifreeze mode not use	2 
	2  Antifreeze mode	
Reserved	  3 3 Reserved	3 
Reserved	  4 4 Not Use	4 

NOTE**Emergency Operation****• Definition of terms**

- Trouble : a problem which can stop system operation, and can be resumed temporarily under limited operation without certificated professional's assist.
- Error : problem which can stop system operation, and can be resumed ONLY after certificated professional's check.
- Emergency mode : temporary heating operation while system met Trouble.

• Objective of introducing 'Trouble'

- Not like airconditioning product, Air-to-Water heat pump is generally operation in whole winter season without any system stopping.
- If system found some problem, which is not critical to system operating for yielding heating energy, the system can temporarily continue in emergency mode operation with end user's decision.

• Classified Trouble

- Trouble is classified two levels according to the seriousness of the problem : Slight Trouble and Heavy trouble
- Slight Trouble : a problem is found inside the unit. In most case, this trouble is concerned with sensor problems. The outdoor unit is operating under emergency mode operation condition which is configured by DIP switch No. 4 of the unit PCB.
- Heavy trouble : a problem is found inside the outdoor unit. As the outdoor unit has problem, the emergency mode operation is performed by electric heater located in the unit.
- Option Trouble : a problem is found for option operation such as water tank heating. In this trouble, the troubled option is assumed as if it is not installed at the system.

• When the AWHP has any trouble,

(1) If there is not a function to judge possibility of operation :

Once an error occurs mainly in indoor unit, AWHP stops. On the other hand, Remocon allows the product to activate On/ Off operation. (On : emergency operation)

- Slight / Heavy trouble : Heating Operable only
- Critical trouble : Full stop
- Treatment priority : Critical>Heavy>Slight

(2) If there is a function to judge possibility of operation :

Depending on the status of slight / heavy / critical trouble, pop-up phrase is guided separately on display.

- Slight trouble : Heating/Cooling Operable
- Heavy trouble : Heating Operable only
- Critical trouble : Service center request

AWHP operates when user pressed OK button on pop-up window.

NOTE**• Duplicated trouble : Option trouble with slight or heavy trouble**

- If option trouble is occurred with slight (or heavy) trouble at the same time, the system puts higher priority to slight (or heavy) trouble and operates as if slight (or heavy) trouble is occurred.
- Therefore, sometimes DHW heating can be impossible in emergency operation mode. When DHW is not warming up while emergency operation, please check if DHW sensor and related wiring are all Ok.

• Emergency operation is not automatically restarted after main electricity power is reset.

- In normal condition, the product operating information is restored and automatically restarted after main electricity power is reset.
- But in emergency operation, automatic re-start is prohibited to protect the product.
- Therefore, user must restart the product after power reset when emergency operation has been running.

SERVICE SETTING

How to enter service setting

To enter the menu displayed at the bottom, you need to enter the service setting menu as follows.

- In the menu screen, press [←,→(left/right)] button to select the setting category, and press [OK] button to move to the setting list.
- In the setting list, select the service setting category, and press [OK] button to move to the service setting list.

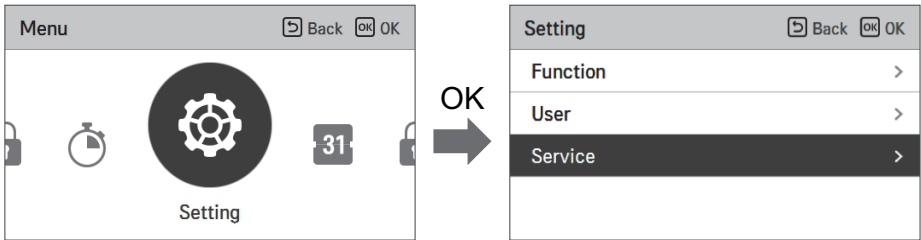

Service setting

- You can set the product service functions.
- Some functions may not be displayed/operated in some product types.

Menu	Description
Service contact	Check and input the service center phone number that you can call when there is service issue.
Model information	View product and capacity information
RMC Version Information	Check the remote controller model name and software version.
Open Source License	View the remote controller's open source license.

Service contact

Check and input the service center phone number that you can call when there is service issue.

- In the service setting list, select the service contact point and press [OK] button to move to the detail screen.
- While “edit” button is selected, press [OK] button to move to the edit screen, change it, and press [OK] button to change the service contact point.

Service		Back	OK
Service Contact	>		
Model Information	>		
RMC Version Information	>		
Open Source License	>		



Service Contact		Back	OK
Telephone +1544-7777			
Edit			



Service Contact		Back	OK
Telephone			
+	1	5	4 4 - 7 7
7	7		

Model information

Check product and capacity information to which the remote controller is connected.

- In the service setting list, select model information category, and press [OK] button to move to the detail screen.
- The unit capacity
 - $1 \text{ kWh} = 1 \text{ kBtu} * 0.29307$
 - kWh is the result calculated based on Btu, There may be a small difference between calculated and actual capacity.
 - Ex) If the unit capacity is 18 kBtu, it is displayed as 5 kWh.

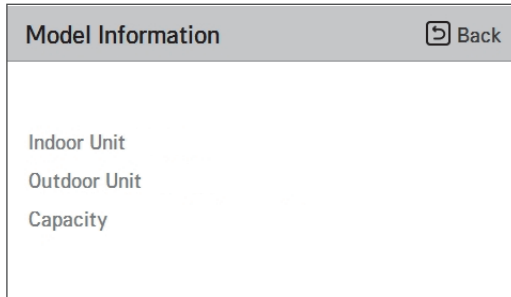
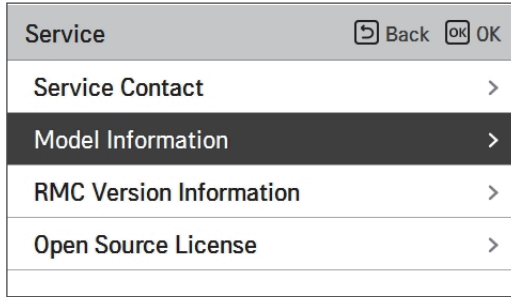

RMC version Information

View the remote controller software version.

- In the service setting list, select the RMC version information and press [OK] button to move to the detail screen

Service	⏪ Back	OK
Service Contact		>
Model Information		>
RMC Version Information		>
Open Source License		>



RMC Version Information	⏪ Back
SW Version 3.03.1a	

Open source license

View the remote controller's open source license.

- In the service setting list, select the open source license category, and press [OK] button to move to the detail screen.

Service	Back	OK
Service Contact	>	
Model Information	>	
RMC Version Information	>	
Open Source License	>	



Open Source License		Back
LGE Open Source Software Notice		
Product Type	HVAC WIRED REMOTE CONTR	
Model Number/Range	RS3 Wired Remote Controller	1/401
Those products identified by the Product Type and Model Range above from LG Electronics, Inc. ("LGE") contain the open source software detailed below. Please refer to the		

Installer setting

- You can set the product user functions.
- Some functions may not be displayed/operated in some product types.

Function	Description
3 Minutes Delay	Factory use only
Select Temperature Sensor	Selection for setting temperature as air temperature or leaving water temperature or air+leaving water temperature
Dry Contact Mode	Dry contact function is the function that can be used only when the dry contact devices is separately purchased and installed.
Pump Test run	Water pump test run
Air cooling set temp.	Adjusting range of 'Setting Air Temperature' in cooling mode
Water cooling set temp.	Adjusting range of 'Setting Leaving Water Temperature' in cooling mode
Air heating set temp.	Adjusting range of 'Setting Air Temperature' in heating mode
Water heating set temp.	Adjusting range of 'Setting Heating Flow Temperature' in heating mode
DHW Set Temp.	Setting DHW set temperature
Water supply off temp. during cooling	Determine leaving water temperature when the unit is turned off. This function is used for preventing condensation on the floor in cooling mode
Heater priority	Determine electric heater and water heater on and off
DHW time setting	Determine follow time duration : operation time of domestic hot water tank heating, stop time of domestic hot water tank heating, and delay time of DHW tank heater operating
TH on/off Variable, heating air	Heating air temperature TH On / Off Type setting
TH on/off Variable, heating Water	Heating Water Outlet Temperature TH On / Off Type

Function	Description
TH on/off Variable, cooling air	Cooling air temperature TH On / Off Type setting
TH on/off Variable, cooling water	Cooling Water Outlet Temperature TH On / Off Type
Heating temp. setting	At the leaving water control in heating mode, the control reference water temperature position setting
Cooling temp. setting	At the leaving water control in cooling mode, the control reference water temperature position setting
Pump setting in heating	Set water pump on / off delay option in heating mode
Pump setting in cooling	Set water pump on / off delay option in cooling mode
Forced operation	Water pump off After 20 consecutive hours, disable / enable the logic that drives the water pump by itself
CN_CC	It is the function to set whether to install (use) Dry Contact. (It is not a function for Dry Contact installation, but it is a function to set the usage of the unit's CN_CC port.)
Pump frequency setting(RPM)	Function to change Water Pump RPM
Pump Capacity	Function to change Water Pump Capacity
CN_EXT	Function to set external input and output control according to DI / DO set by customer using dry contact port of indoor unit. Determine the use of the contact port (CN_EXT) mounted on the indoor unit PCB
Anti-freezing Temperature	This function prevents the product from freezing.
Pump Prerun/Overrun	Set to reach the optimum flow rate by circulating the heating water with the water pump before heat exchange. After the operation stop, additional water pump is activated to circulate the heating water.
Solar Thermal System	Function to set operation reference value in Solar Thermal System.
Current flow rate	Function to check the current flow rate.
Data logging	Display error history of connected unit
Password Initialization	It is the function to initialize (0000) the password when you forgot the password set in the remote controller.

3 Minutes Delay

Temporarily eliminates the 3-minute delay function of the outdoor unit Comp factory use only

- In the installer setting list, select 3 Minutes Delay category, and press [OK] button to move to the detail screen.

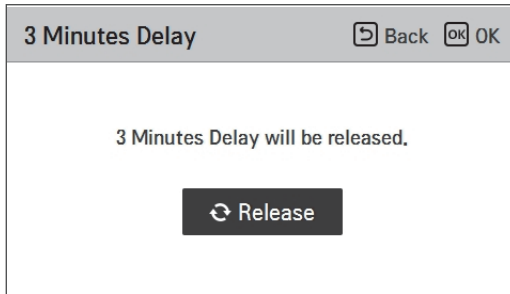
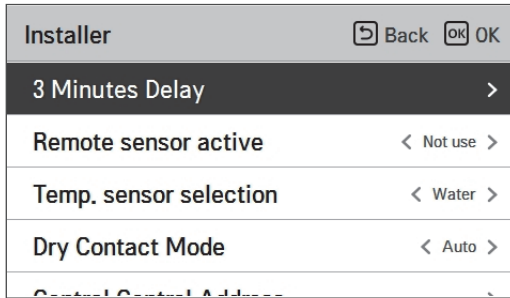

Select Temperature Sensor

The product can be operated according to air temperature or leaving water temperature. The selection for setting temperature as air temperature or leaving water temperature is determined.

- In the installer setting list, Select Temperature Sensor category, and press [OK] button to move to the detail screen.

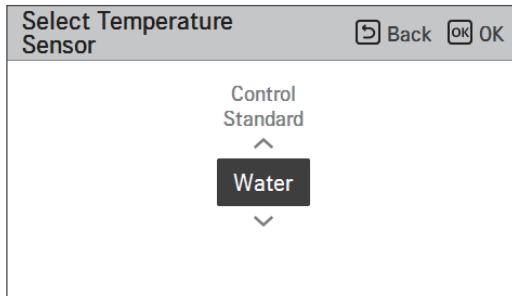
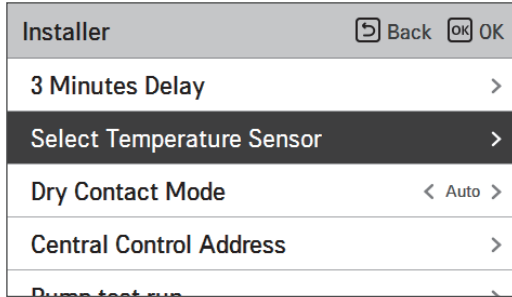

Value	
Water	Air

NOTE

Air temperature as setting temperature is ONLY available when Remote Air Sensor Connection is enabled and Remote Air Sensor Connection is set as 02.

Dry Contact Mode

Dry contact function is the function that can be used only when the dry contact devices is separately purchased and installed.

- Change setting values using [<,>(left/right)] button.

Installer		Back	OK
3 Minutes Delay		>	
Remote sensor active	< Not use >		
Temp. sensor selection	< Water >		
Dry Contact Mode	< Auto >		
Control Control Address			

Value
Auto
manual

NOTE

For dry contact mode related detail functions, refer to the individual dry contact manual.

What is dry contact?

It means the contact point signal input when the hotel card key, human body detection sensor, etc. are interfacing with the air conditioner.

Added system functionality by using external inputs (dry contacts and wet contacts).

Pump test run

The pump test run is the function to test run by operating the water pump. This function can be used for air vents / flow sensors and others.

- In the installer setting list, Pump Test run category, and press [OK] button to move to the detail screen.

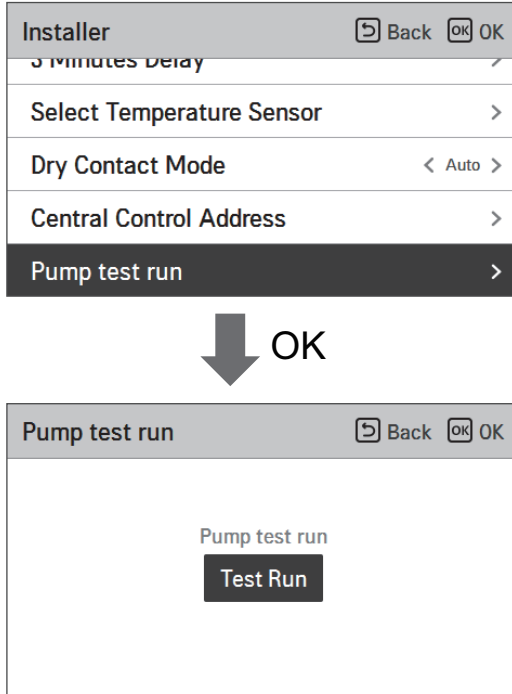

Air cooling set temp.

Determine cooling setting temperature range when air temperature is selected as setting temperature.

- In the installer setting list, select Air cooling set temp category, and press [OK] button to move to the detail screen.

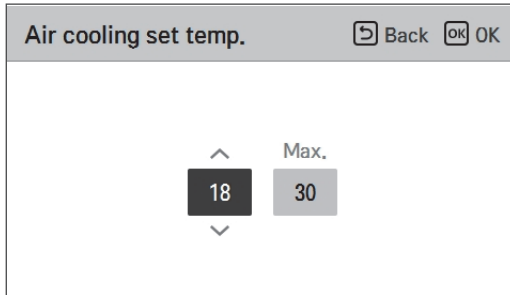
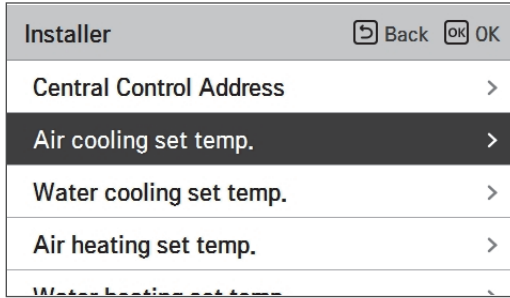

Value	Default	Range
Max.	30	24~30
Min.	16	16~22

* Upper / lower limit / default value is in °C

NOTE

Only available when remote air temperature sensor is connected.

- Accessory PQRSTA0 should be installed.
- Also, Remote air sensor connection should be set properly.

Water cooling set temp.

Determine cooling setting temperature range when leaving water temperature is selected as setting temperature.

- In the installer setting list, select water cooling set temp category, and press [OK] button to move to the detail screen.

The screen shows the 'Installer' menu with the following options: Central Control Address, Air cooling set temp., Water cooling set temp. (highlighted), Air heating set temp., and Water heating set temp. The 'Back' and 'OK' buttons are visible in the top right corner.



The detail screen for 'Water cooling set temp.' shows a current value of 5 and a maximum value of 24. The 'Back' and 'OK' buttons are visible in the top right corner.

Value	Default	Range
Max.	24	20~25
Min.	16	16~20

* Upper / lower limit / default value is in °C

NOTE

Water condensation on the floor

- While cooling operation, it is very important to keep leaving water temperature higher than 16 °C. Otherwise, dew condensation can be occurred on the floor.
- If floor is in humid environment, do not set leaving water temperature below 18 °C.

NOTE

Water condensation on the radiator

- While cooling operation, cold water may not flow to the radiator. If cold water enters to the radiator, dew generation on the surface of the radiator can be occurred.

Air heating set temp.

Determine heating setting temperature range when air temperature is selected as setting temperature

- In the installer setting list, select Air heating set temp. category, and press [OK] button to move to the detail screen.

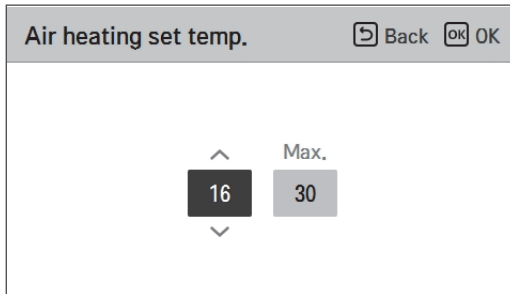
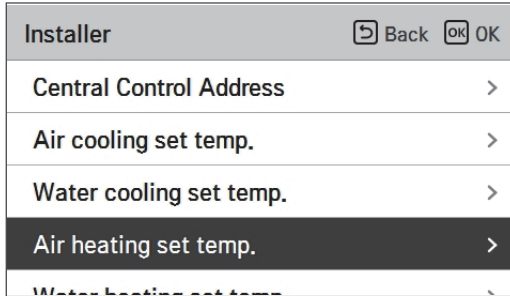

Value	Default	Range
Max.	30	24~30
Min.	16	16~22

* Upper / lower limit / default value is in °C

CAUTION

Only available when remote air temperature sensor is connected.

- Accessory PQRSTA0 should be installed.
- Also, Remote air sensor connection should be set properly.

Water heating set temp.

Determine heating setting temperature range when leaving water temperature is selected as setting temperature.

- In the installer setting list, select Water heating set temp. category, and press [OK] button to move to the detail screen.

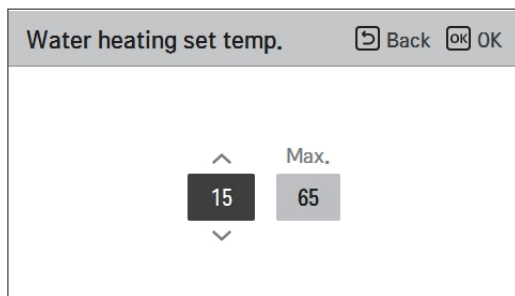
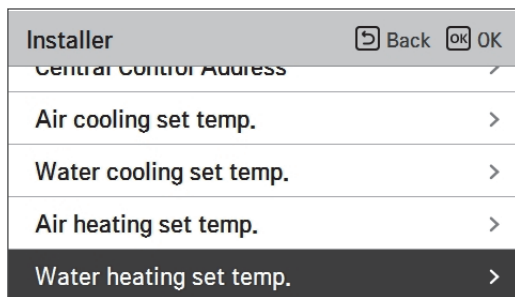

Value	Default	Range
Max.	50	35~50
Min.	20	20~34

* Upper / lower limit / default value is in °C.

NOTE

- When the E/heater is not used, the minimum temperature of the water temperature can be set from 34 °C to 20 °C.

DHW set temp.

Determine heating setting temperature range when DHW temperature is selected as setting temperature

- In the installer setting list, select DHW set temp. category, and press [OK] button to move to the detail screen.

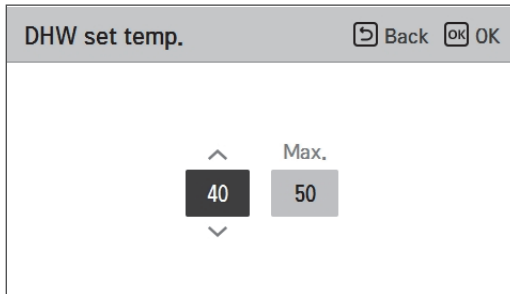
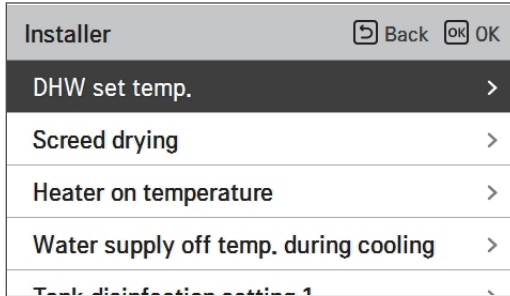

Value	Range
Max.	50
Min.	40

* Upper / lower limit / default value is in °C

Water supply off temp. during cooling

Determine leaving water temperature when the unit is turned off. This function is used for preventing condensation on the floor in cooling mode

- In the installer setting list, select Water supply off temp. during cooling category, and press [OK] button to move to the detail screen.

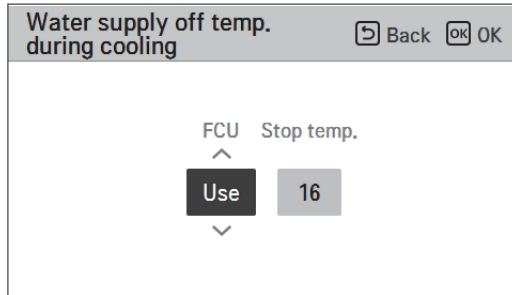
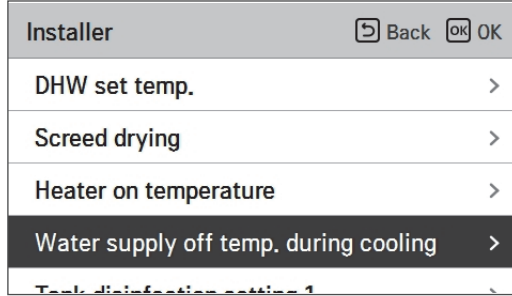

Function	Value	Default	Setting Rang
cooling water temperature	Water supply off temperature	16	25~16
	FCU Use/ not use	use	Use / Not Use

- Stop temp. : cut-off temperature. Stop temp. is valid when FCU is installed.
- FCU : determines if FCU is installed or not.
- Example : If Stop temp. is set as '10' and FCU is 'Use' and actually FCU is NOT installed in the water loop, the unit stop operation in cooling mode when the leaving water temperature is below 10 °C.
- Example : If Stop temp. is set as '10' and FCU is 'Not use' and actually FCU is installed in the water loop, the Stop temp. is not used and the unit do NOT stop operation in cooling mode when the leaving water temperature is below 10 °C.



CAUTION

FCU Installation

- If FCU is used, related 2way valve should be installed and connected to the unit PCB.
- If FCU is set as 'Not use' but FCU or 2way valve is NOT installed, the unit can do abnormal operation.

Heater priority

- Heater priority : determine electric heater and DHW tank heater on and off.
- Example : If Heater priority is set as 'Main+Boost heater ON', then electric heater and DHW tank heater are on and off according to control logic. If Heater priority is set as 'Boost heater only ON', then electric heater is never turned on and only DHW tank heater is on and off according to control logic.
- In the installer setting list, heater priority category, and press [OK] button to move to the detail screen.

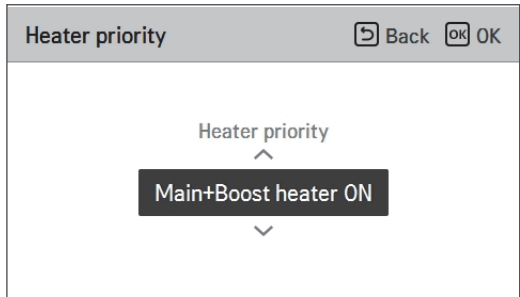
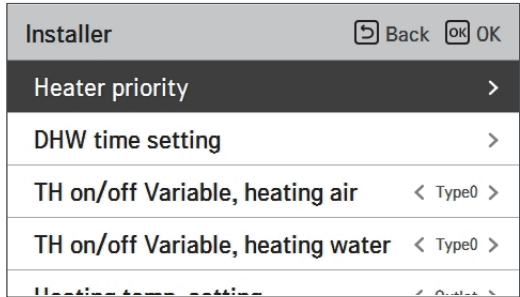

Value	
Boost heater only ON	Main+Boost heater ON

DHW time setting

Determine following time duration : operation time of DHW tank heating, stop time of DHW tank heating, and delay time of DHW tank heater operating.

- Active time : This time duration defines how long time DHW tank heating can be continued.
- Stop time : This time duration defines how long time DHW tank heating can be stopped. It is also regarded as time gap between DHW tank heating cycle.
- Boost heater delay time : This time duration defines how long time DHW tank heater will not be turned on in DHW heating operation.
- Example of timing chart :

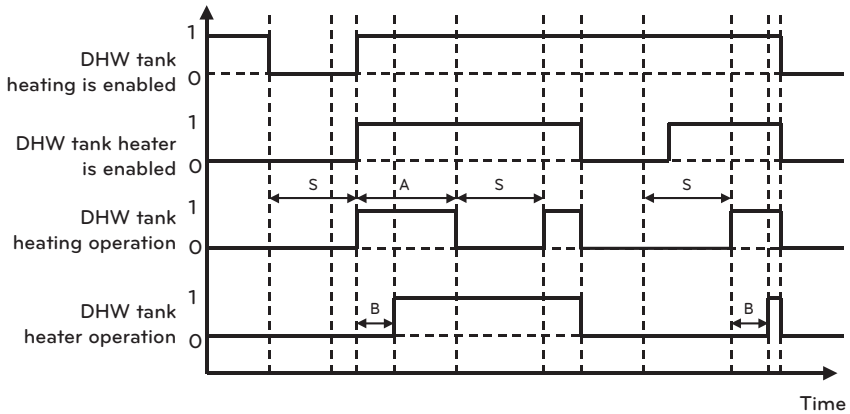

※ 1=active / 0=not active

※ A = Active time

※ S = Stop time

※ B = Boost heater delay time

Installer		Back	OK
Heater priority	>		
DHW time setting	>		
TH on/off Variable, heating air	< Type0 >		
TH on/off Variable, heating water	< Type0 >		
Heating temp. setting	< Type0 >		

OK



DHW time setting			Back	OK
Active time	Stop time	Boost heater delay time		
30	180	20		

TH on/off Variable, heating air

It is a function to adjust the heating air temperature Thermal On / Off temperature according to the field environment in preparation for heating or heating claim.

- You can set the following setting values using [<, >(left/right)] button.

Installer	Back	OK
Heater priority		>
DHW time setting		>
TH on/off Variable, heating air	< Type0	>
TH on/off Variable, heating water	< Type0	>
Heating temp. setting		>

Value	Description	
	TH On	TH Off
Type0	-0.5 °C	1.5 °C
Type1	-1 °C	2 °C
Type2	-2 °C	3 °C
Type3	-3 °C	4 °C

TH on/off Variable, heating water

It is a function to adjust the heating water temperature Thermal On / Off temperature according to the field environment in preparation for heating or heating claim.

- You can set the following setting values using [<,>(left/right)] button.



Installer	⏪ Back	OK ⏩
Heater priority		>
DHW time setting		>
TH on/off Variable, heating air	<	Type0 >
TH on/off Variable, heating water	<	Type0 >
Heating temp. setting		>

Value	Description	
	TH On	TH Off
Type0	-2 °C	2 °C
Type1	-3 °C	3 °C
Type2	-4 °C	4 °C
Type3	-1 °C	1 °C

TH on/off Variable, cooling air

It is a function to adjust the cooling air temperature Thermal On / Off temperature according to the field environment in preparation for cooling or cooling claim.

- You can set the following setting values using [\leftarrow , \rightarrow (left/right)] button.

Installer	 Back	 OK
TH on/off Variable, heating air	\leftarrow Type0	\rightarrow
TH on/off Variable, heating water	\leftarrow Type0	\rightarrow
TH on/off Variable, cooling air	\leftarrow Type0	\rightarrow
TH on/off Variable, cooling water	\leftarrow Type0	\rightarrow
Pump setting in heating		\downarrow

Value	Description	
	TH On	TH Off
Type0	0.5 °C	-0.5 °C
Type1	1 °C	-1 °C
Type2	2 °C	-2 °C
Type3	3 °C	-3 °C

TH on/off Variable, cooling water

It is a function to adjust the cooling water temperature Thermal On / Off temperature according to the field environment in preparation for cooling or cooling claim.

- You can set the following setting values using [<,>(left/right)] button.

Installer	Back	OK
TH on/off Variable, heating air	<	Type0 >
TH on/off Variable, heating water	<	Type0 >
TH on/off Variable, cooling air	<	Type0 >
TH on/off Variable, cooling water	<	Type0 >
Pump setting in heating		

Value	Description	
	TH On	TH Off
Type0	0.5 °C	-0.5 °C
Type1	1 °C	-1 °C
Type2	2 °C	-2 °C
Type3	3 °C	-3 °C

Heating temp. setting

- At the leaving water control in heating mode, the control reference water temperature position setting
- If the air / leaving water temperature selection setting is set to leaving water temperature
- Change setting values using [<,>(left/right)] button
- The function is not available for some products.

Installer		Back	OK
heater priority			
DHW time setting			>
TH on/off Variable, heating air	<	Type0	>
TH on/off Variable, heating water	<	Type0	>
Heating temp. setting	<	Outlet	>

Value	
Outlet (Default)	Inlet

Cooling temp. setting

- At the leaving water control in cooling mode, the control reference water temperature position setting
- If the air / leaving water temperature selection setting is set to leaving water temperature
- Change setting values using [,>(left/right)] button.
- The function is not available for some products.

Installer		Back	OK
DRW time setting			
TH on/off Variable, heating air	<	Type0	>
TH on/off Variable, heating water	<	Type0	>
Heating temp. setting	<	Outlet	>
Cooling temp. setting	<	Outlet	>

Value	
Outlet (Default)	Inlet

Pump setting in heating

- It is a function to help the water pump's mechanical life by putting the water pump's rest time
- Installer setting function to set water pump operation / delay time option in heating mode
- In the installer setting list, select Pump setting in heating category, and press [OK] button to move to the detail screen.

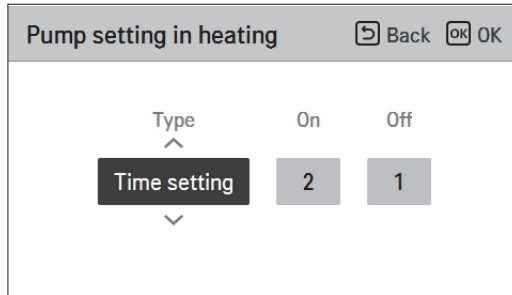
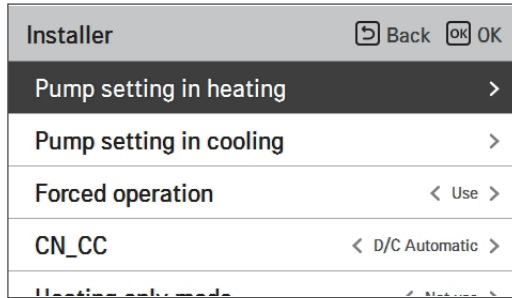

Type	Time setting	Operation continue
On	1 min ~ 60 min	-
Off	1 min ~ 60 min	-

Pump setting. in cooling

- It is a function to help the water pump's mechanical life by putting the water pump's rest time
- installer setting function to set water pump operation / delay time option in cooling mode
- In the installer setting list, select Pump setting in cooling category, and press [OK] button to move to the detail screen.

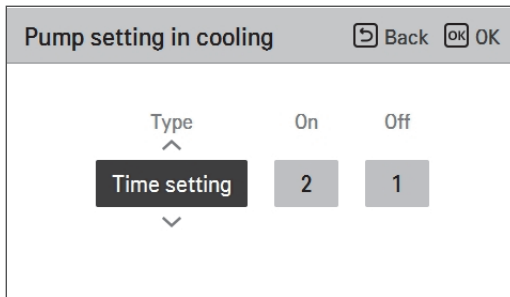
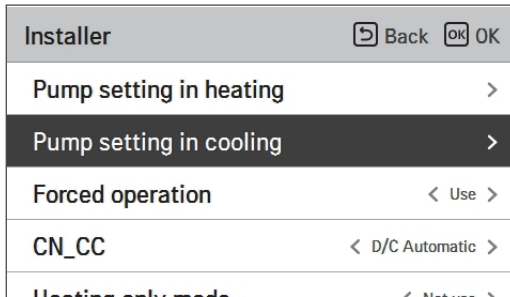

Type	Time setting	Operation continue
On	1 min ~ 60 min	-
Off	1 min ~ 60 min	-

Forced operation

- If the product is not used for a long time, the product will be forced to operate to prevent pump failure and PHEX freezing
- Water pump off After 20 consecutive hours, disable / enable the logic that drives the water pump by itself
- In the installer setting list, select Forced operation category, and press [OK] button to move to the detail screen

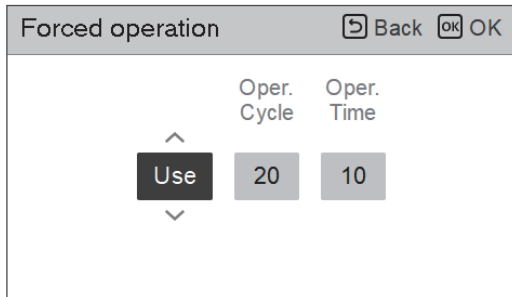
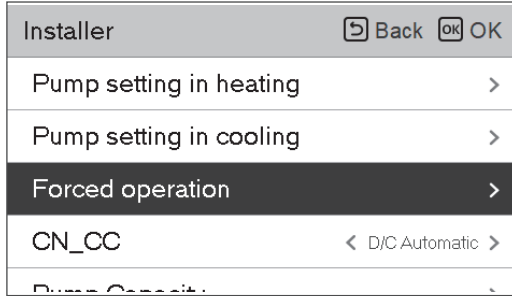

Type	Use	Not use
Oper. Cycle	20 hours ~ 180 hours	-
Oper. Time	1 min ~ 10 min	-

CN_CC

It is the function to set the usage of the unit's CN_CC port.

- Change setting values using [<,>(left/right)] button

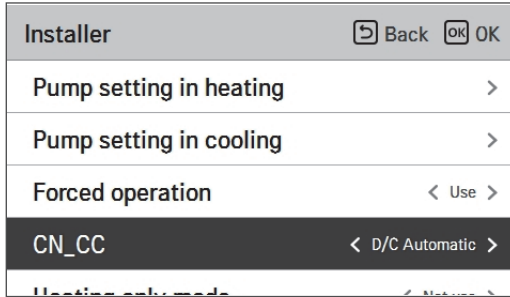

Value	Description
D/C Automatic	When power is applied to the product, the unit when the contact point is on in Dry Contact installed state recognizes Dry Contact installation
D/C Not Installed	Do not use (install) Dry Contact
D/C Installed	Use (install) Dry Contact

NOTE

CN_CC is the device connected to the unit to recognize and control the external contact point.

Pump frequency setting (RPM)

It is a function to enable installer to control pump RPM of AC pump application model.

- In the installer setting list, select Pump frequency setting(RPM) category, and press [OK] button to move to the detail screen.
- The function is not available for some products.

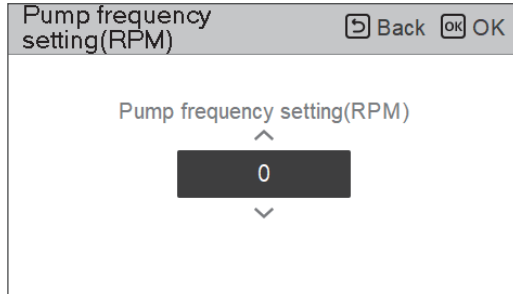
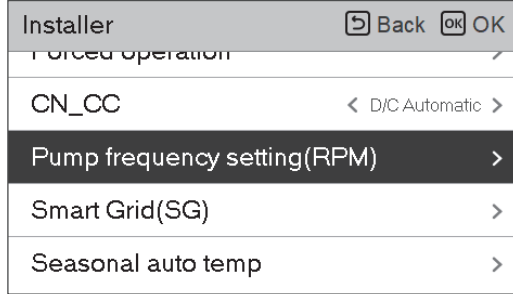

Value	Description
3 500	500~3 700 : RPM Change unit : 10

Pump Capacity

It is a function to enable installer to control Pump capacity application model.

- In the installer setting list, select Pump Capacity category, and press [OK] button to move to the detail screen.
- The function is not available for some products.

Installer		Back	OK
Forced operation		>	
CN_CC	<	D/C Automatic	>
Pump Capacity		>	
Smart Grid(SG)		>	
Success auto temp		>	



Pump Capacity		Back	OK
% ^ <div style="background-color: black; color: white; padding: 5px; display: inline-block;">0</div> v			

Value	Description
100 (Default)	10~100 : % Change unit: 5

CN_EXT

It is a function to control external input and output according to DI type set by customer using CN-EXT Port.

- In the installer setting list, select CN-EXT Port category, and press [OK] button to move to the detail screen.

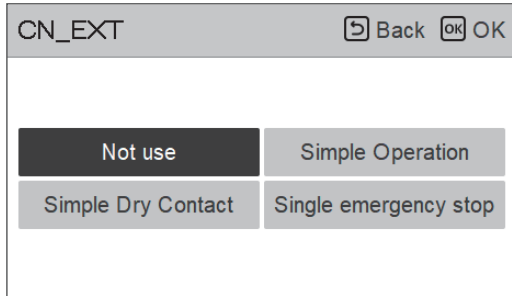
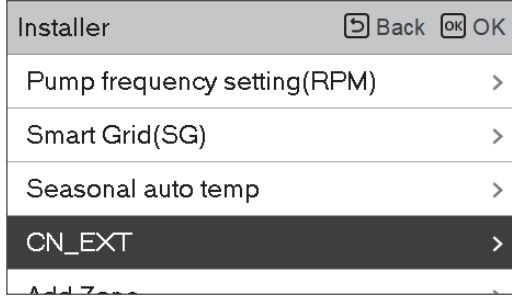

Value			
Not use	Simple Operation	Simple Dry Contact	Single emergency stop

Anti-freezing Temperature

Anti-freeze temperature setting is available in installer mode. It prevents frostbite from happening in the range of -25 to -5 degree celsius.

- Change setting values using [**<**, **>**(left/right)] button.
- The function is not available for some products.

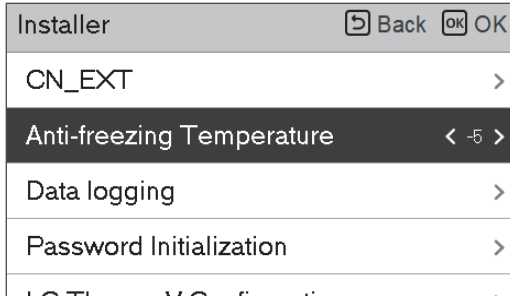

NOTE

To use this function, the antifreeze short pin(CN_FLOW2) must be open and switch No.2 in Option SW 3 must be on.

Pump Prerun/Overrun

Pump Prerun operates to ensure sufficient flow before the compressor is operated. This is a function that allows heat exchange to work smoothly.

Pump Overrun is a function to prevent water pump failure and to help mechanical life. If the water pump has been off for 20 hours, Water pump will operate for the set time

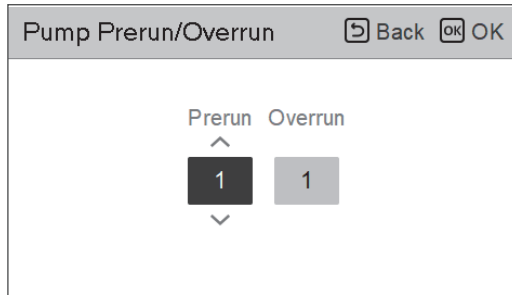
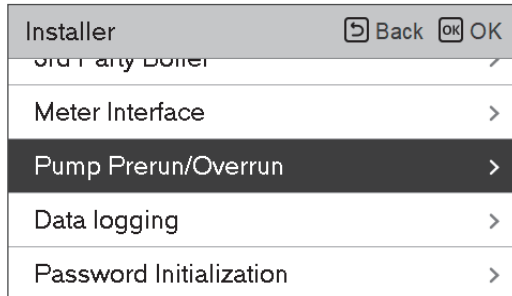

Value	Default	Setting Range
Prerun	1 min	1~10 min
Overrun	1 min	1~10 min

Solar Thermal System

It is function to set operation reference value in Solar Thermal System.

In the installer setting list, select Solar thermal system category, and press [OK] button to move to the detail screen.

Installer		Back	OK
IDU operation time	>		
Solar Thermal System	>		
Data logging	>		
Password Initialization	>		
LO Thermal Configuration	>		

Solar Thermal System		Back	OK
Solar collector set temp	>		
DHW set temp.	>		
TH on/off Variable, solar	>		
Boost Heater	>		
Solar pump flush schedule	>		

Solar collector set temp		Back	OK
Min.	Max.		
10	95		

DHW set temp.		Back	OK
Max.			
80			

TH on/off Variable, solar		Back	OK
Temp On	Temp Off		
8	2		

Boost Heater		Back	OK
Boost Heater			
Enable			

Solar pump flush schedule		Back	OK
Control	Start Hour	Start Minute	End Hour
On	06	: 00	18
			: 00

Solar pump flush setting		Back	OK
Oper. Cycle	Oper. Time		
60	1		

Solar pump test run		Back	OK
Solar pump test run			
Stop			

NOTE

To use this function, switch No.2 of option switch 2 must be turned ON and No.3 of option switch 2 must be turned OFF.

Descriptions for each parameters are as following.

- Solar collector set temp
 - Min temp : It is the minimum solar collector temperature at which the solar thermal system can operate.
 - Max temp : It is the maximum solar collector temperature at which the solar thermal system can operate.
- TH on/off Variable, solar
 - Temp on : It is the temperature difference between the current solar thermal temperature and DHW tank temperature at which the solar thermal system operates.
 - Temp off : It is the temperature difference between the current solar thermal temperature and DHW tank temperature at which the solar thermal system stops.
 - Example : If the current solar collector temperature is 80 °C and Temp on is set to 8 °C, the solar thermal system operates when the DHW tank temperature is less than 72 °C. In the same case, if Temp off is set to 2 °C, Solar Thermal System stops when DHW temperature is 78 °C.
- DHW Set Temp
 - Max : It is maximum temperature of DHW that can be reached by solar thermal system.
- Boost Heater
 - Enable : DHW tank heater can be used when operating the Solar Thermal system.
 - Disable : DHW tank heater cannot be used when operating the Solar Thermal system.
- Solar pump flush schedule
 - It is the function to circulate the solar water pump intermittently for solar collector temperature detection when the solar water pump does not operate for a long time. Turn on to use this function.
- Solar Pump flush setting
 - Oper.Cycle : When using the solar pump flush function, the solar water pump operates at the set time.
 - Oper.Time : When using the solar pump flush function, the solar water pump operates during the set time.

Function	Value	Range	Default
Solar collector set temp	Min	5 °C ~ 50 °C	10 °C
	Max	60 °C~105 °C	95 °C
DHW set temp	Max	20 °C~90 °C	80 °C
TH on/off Variable, solar	Temp On	3 °C ~ 40 °C	8 °C
	Temp Off	1 °C ~ 20 °C	2 °C
Boost Heater	Boost Heater	Enable/Disable	Enable
Solar pump flush schedule	On/OFF	On/Off	On
	Start Hour, Start Minute	00:00 ~ 24:00	6:00
	End Hour, End Minute	00:00 ~ 24:00	18:00
Solar pump test run	Pump test Run	Start/Stop	Stop
Solar pump flush setting	Oper.Cycle	30 min ~ 120 min	60 min
	Oper.Time	1 min ~ 10 min	1 min

Current flow rate

It is the function to check the current flow rate.

- In the installer setting list, select Current Flow Rate category, and press [OK] button to move to the detail screen. The current flow rate can be checked. (Range : 7 ~ 80 L/min)
- The function is not available for some products.

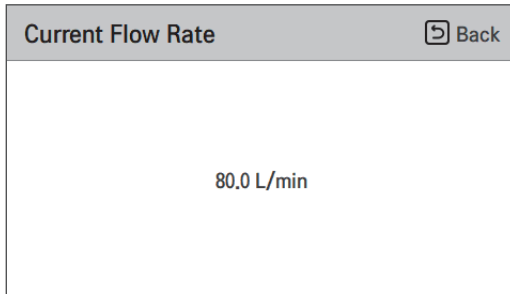
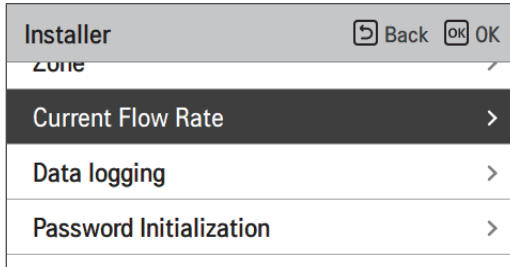

Data logging

It is the function to set the operation reference value in Seasonal Auto mode.

- In the installer setting list, select Data logging category, and press [OK] button to move to the detail screen.

Installer		Back	OK
Heating only mode			
Pump frequency setting(PWM)			>
Smart Grid(SG)			>
Seasonal auto temp			>
Data logging			>



Data logging					Back
Date	Time	Oper.	Settemp	In/Out	
1970.01.01	00:10	Off	-	24° / 25°	
1970.01.01	00:09	Off	-	24° / 25°	
1970.01.01	00:09	Off	-	24° / 25°	>
1970.01.01	00:09	Off	-	24° / 25°	
1970.01.01	00:09	Off	-	24° / 25°	

NOTE

Error history lookup range: 50

Error history information

Item: date, time, mode (including Off), set temperature, incoming temperature, outgoing temperature, room temperature, Hot water operation / stop, Hot water set temperature, Hot water temperature, Outdoor unit On / Off, Error code

Number of Display: Within 50

- Save criteria ▾

▸ Error occurred, released ON / OFF of outdoor unit operation.

Password Initialization

It is the function to initialize (0000) when you forgot the password set in the remote controller.

- In the installer setting list, select the password initialization setting category, and press [OK] button to move to the detail screen.
- When you press "initialization" button, a popup screen appears, and when you press "check" button, password initialization starts, and the user password is changed to 0000.

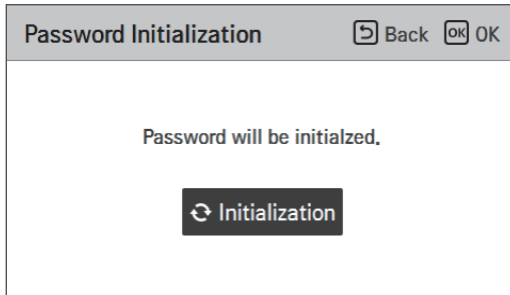
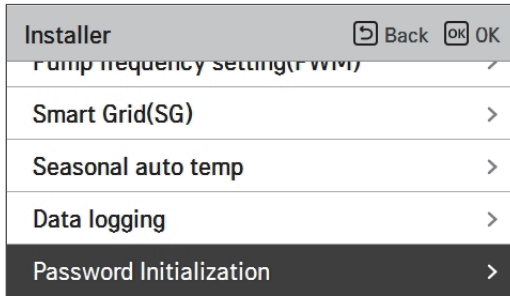

Troubleshooting

If **Hydro Kit** operates not properly or it does not start operation, please check following list.

CAUTION

Turn off the power before proceeding troubleshooting.

Troubleshooting for Problem while Operation

No	Problem	Reason	Solution
1	Heating or Cooling is not satisfactory.	<ul style="list-style-type: none"> Setting target temperature is not proper. 	<ul style="list-style-type: none"> Set target temperature correctly. Check if temperature is water-based or air-based. See "Remote sensor active" and "Temp. sensor selection" in Chapter6.
		<ul style="list-style-type: none"> Charged water is not enough. 	<ul style="list-style-type: none"> Check pressure gage and charge more water until pressure gage is indication 2~2.5 Bar
		<ul style="list-style-type: none"> Water flow rate is low. 	<ul style="list-style-type: none"> Check if strainer gathers too much particles. If so, strainer should be cleaned. Check if pressure gauge indicates above 4 Bar Check if water pipe is getting closed due to stacked particles or lime.
2	Although electric power supply is OK (remote controller displays information), the unit does not start working.	<ul style="list-style-type: none"> Water inlet temperature is too high. 	<ul style="list-style-type: none"> If water inlet temperature is above 57 °C, the unit does not operated for the sake of system protection
		<ul style="list-style-type: none"> Water inlet temperature is too low. 	<ul style="list-style-type: none"> If water inlet temperature is below 5 °C in cooling operation, the unit does not operated for the sake of system protection. Wait while unit warms up the water inlet temperature. If water inlet temperature is below 15 °C in heating operation, the unit does not operated for the sake of system protection. Wait while unit warms up to 18 °C the water inlet temperature. If you are not using the back up heater accessory (HA**1M E1), increase the water temperature with the external heat source (heater, boiler). If the problem persists, contact your dealer. If you want to use the screed drying function, be sure to purchase and install back up hater accessories (HA**1M E1).
3	Water pump noise.	<ul style="list-style-type: none"> Air purging is not completely finished. 	<ul style="list-style-type: none"> Open the cap of air purge and charge more water until pressure gage is indicating 2~2.5 Bar If water does not splash out when the tiplat (the top of the hole) is pressed, then air purging is not completed yet. If well purged, the water will splash out like fountain.
		<ul style="list-style-type: none"> Water pressure is low. 	<ul style="list-style-type: none"> Check if pressure gage indicates above 0.3 Bar. Check if the expansion tank and pressure gauge operates well.
4	Water is flood out through drain hose.	<ul style="list-style-type: none"> Too much water is charged. 	<ul style="list-style-type: none"> Flood out water by opening the switch of the safety valve until pressure gage is indicating 2~2.5 Bar.
		<ul style="list-style-type: none"> Expansion tank is damaged. 	<ul style="list-style-type: none"> Replace the expansion tank
5	DHW is not hot.	<ul style="list-style-type: none"> Thermal protector of water tank heater is activated. 	<ul style="list-style-type: none"> Open the side panel of the DHW tank and push the reset button of the thermal protector. (for more detail information, please refer to installation manual of DHW tank.
		<ul style="list-style-type: none"> DHW Heating is disabled. 	<ul style="list-style-type: none"> Select DHW Heating Operation and identify if icon is displayed on the remote controller.

Troubleshooting for Error Code

Display code	Title	Cause of error	Check point & Normal condition
1	Problem in remote room air sensor	<ul style="list-style-type: none"> • Incorrect connection between sensor and PCB(Heater). • PCB(Heater) fault • Sensor fault 	<ul style="list-style-type: none"> • Resistance: 10 kΩ at 25 centigrade (unplugged) → for Remote room air sensor • Resistance: 5 kΩ at 25 centigrade (unplugged) → for all sensors EXCEPT remote room air sensor • Voltage: 2.5 V DC at 25 centigrade (plugged) (for all sensors) • Refer resistance-temperature table to check in different temperature
2	Problem in refrigerant (inlet side) sensor		
6	Problem in refrigerant (outlet side) sensor		
8	Problem in water tank sensor		
13	Problem in solar pipe sensor		
16	Problems in sensors		
17	Problem in water-inlet sensor		
18	Problem in water-outlet sensor		
19	Problem in Electric heater outlet sensor		
10	AC Water pump Lock	Restriction of AC Water pump	<ul style="list-style-type: none"> • AC Water pump defect / assembly condition abnormal • Fan lock by foreign material
3	Bad communication between remote controller and unit.	<ul style="list-style-type: none"> • Incorrect connection between sensor and PCB(Heater) • PCB(Heater) fault • Sensor fault 	<ul style="list-style-type: none"> • Wire connection between remote controller and Main PCB assembly(Heater) should be tight • Output voltage of PCB should be 12 V DC
5	Bad communication between Main PCB assembly(Heater) and Main PCB assembly(Inverter) of the unit.	<ul style="list-style-type: none"> • The connector for transmission is disconnected • The connecting wires are misconnected • The communication line is broken • Main PCB assembly(Inverter) is abnormal • Main PCB assembly(Heater) is abnormal 	<ul style="list-style-type: none"> • Wire connection between remote control panel and Main PCB assembly(Heater) should be tight.
53			
9	PCB program (EEPROM) fault	<ul style="list-style-type: none"> • Electrical or mechanical damage a the EEPROM 	<ul style="list-style-type: none"> • This error can not be permitted
14	Problem in flow switch and flow sensor	<p>Flow switch</p> <ul style="list-style-type: none"> • It is open while internal water pump is working. • It is closed while internal water pump is not working. • It is open while DIP switch No. 5 of Main PCB assembly(Heater) is set as on. <p>Flow sensor</p> <ul style="list-style-type: none"> • Water Pump ON. : If flow rate is not more than 7 LPM or not less than 80 LPM, detect it for 15 seconds. • Water Pump OFF. : If flow rate is not less than 7 LPM, detect it for 15 seconds. 	<p>Flow switch</p> <ul style="list-style-type: none"> • It should be closed while internal water pump is working or DIP switch No. 5 of Main PCB assembly(Heater) is set as on. • It should be open while internal water pump is not working. <p>Flow Sensor</p> <ul style="list-style-type: none"> • Display the flow rate value that received from the indoor unit. (Range : 7 ~ 80 L/min)

Display code	Title	Cause of error	Check point & Normal condition
15	Water pipe overheated	<ul style="list-style-type: none">• Abnormal operation of electric heater• Leaving water temperature is above 57 °C(R410A)/65 °C(R32)	<ul style="list-style-type: none">• If there is no problem in electric heater control, possible maximum leaving water temperature is 57 °C(R410A)/65 °C(R32)
20	Thermal fuse is damaged	<ul style="list-style-type: none">• Thermal fuse is cut off by abnormal overheating of internal electric heater• Mechanical fault at thermal fuse• Wire is damaged	<ul style="list-style-type: none">• This error will not be happened if temperature of electric heater tank is below 80 °C

Airborne Noise Emission

The A-weighted sound pressure emitted by this product is below 70 dB.

** The noise level can vary depending on the site.

The figures quoted are emission level and are not necessarily safe working levels.

Whilst there is a correlation between the emission and exposure levels, this cannot be used reliably to determine whether or not further precautions are required.

Factor that influence the actual level of exposure of the workforce include the characteristics of the work room and the other sources of noise, i.e. the number of equipment and other adjacent processes and the length of time for which an operator exposed to the noise. Also, the permissible exposure level can vary from country to country.

This information, however, will enable the user of the equipment to make a better evaluation of the hazard and risk.

Model Designation

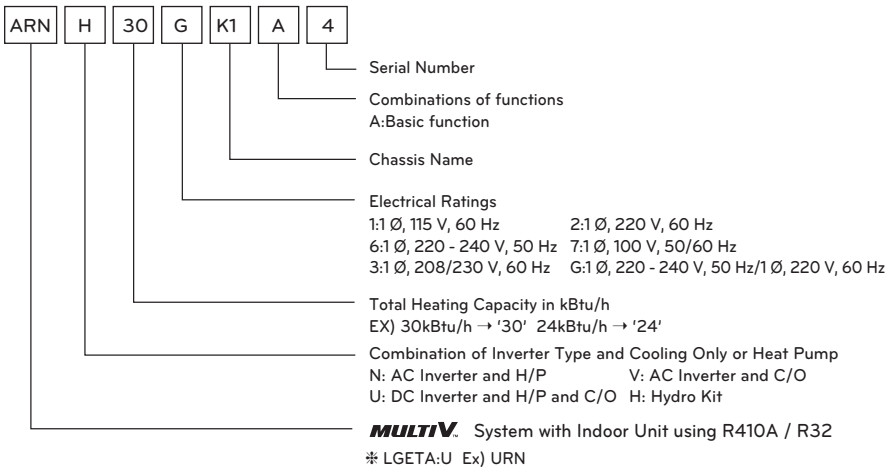



LG Electronics Inc. Single Point of Contact (EU/UK) :
LG Electronics European Shared Service Center B.V.
Krijgsman 1, 1186 DM Amstelveen, The Netherlands

Manufacturer :
LG Electronics Inc.
84, Wanam-ro, Seongsan-gu, Changwon-si, Gyeongsangnam-do, KOREA

UK Importer : LG Electronics U.K. Ltd
Velocity 2, Brooklands Drive, Weybridge, KT13 0SL

Eco design requirement

- The information for Eco design is available on the following free access website.
<https://www.lg.com/global/support/cedoc/cedoc>