

INSTALLATION MANUAL

AIR CONDITIONER

Please read this installation manual completely before installing the product.
Installation work must be performed in accordance with the national wiring standards
by authorized personnel only.
Please retain this installation manual for future reference after reading it thoroughly.

Air-to-Water Heat Pump

THERMAV™

Original instruction

[Representative] LG Electronics Inc. EU Representative : LG Electronics European Shared
Service Center B.V. Krijgsman 1, 1186 DM Amstelveen, The Netherlands

[Manufacturer] LG Electronics Inc. Changwon 2nd factory 84, Wanam-ro, Seongsan-gu,
Changwon-si, Gyeongsangnam-do, KOREA

For more information, Refer to the CD or LG Web site (www.lg.com).



P/NO : MFL68026603

www.lg.com

ENGLISH

ITALIANO

ESPAÑOL

FRANÇAIS

DEUTSCH

ΕΛΛΗΝΙΚΑ

ČEŠTINA

NETERLANDS

POLSKI

LIMBA ROMÂNĂ

TABLE OF CONTENTS

1. SAFETY PRECAUTIONS	3
2. INSTALLATION PARTS	8
3. GENERAL INFORMATION	9
MODEL INFORMATION.....	9
COMPONENTS	10
ACCESSORIES	13
4. INSTALLATION	15
TRANSPORTING THE UNIT	15
SELECTION OF THE BEST LOCATION	16
INSTALLATION CONDITIONS.....	17
INSTALLATION AT SEASIDE.....	18
SEASONAL WIND AND CAUTIONS IN WINTER.....	18
FOUNDATION FOR INSTALLATION	19
INSTALLATION SCENES	20
WATER PIPING AND WATER CIRCUIT CONNECTION.....	23
WATER VOLUME AND EXPANSION VESSEL PRESSURE.....	27
ELECTRICAL WIRING.....	28
CONNECTING CABLES.....	30
WIRING OF MAIN POWER SUPPLY AND EQUIPMENT CAPACITY	35
WATER CHARGING	36
INSTALLATION OF THE FINAL CHECK	37
5. ACCESSORIES INSTALLATION	38
INSTALLATION OF REMOTE CONTROLLER	38
THERMOSTAT	40
SANITARY WATER TANK AND SANITARY WATER TANK KIT	44
DRY CONTACT.....	47
REMOTE TEMPERATURE SENSOR.....	48
3WAY VALVE	49
AIR-VENT	50
2WAY VALVE	51
6. SYSTEM SET-UP	52
DIP SWITCH SETTING.....	52
INSTALLER SETTING	56
7. CHECK POINTS, MAINTENANCE AND TROUBLESHOOTING	71
CHECK LIST BEFORE STARTING OPERATION	71
MAINTENANCE	72
TEST RUN	72
AIRBORNE NOISE EMISSION	73
LIMITING CONCENTRATION	73
VACUUM & CHARGE OF REFRIGERANT	74
TROUBLESHOOTING	77

1. Safety Precautions

To prevent injury to the user or other people and property damage, the following instructions must be followed.

- Be sure to read before installing the unit.
- Be sure to observe the cautions specified here as they include important items related to safety.
- Incorrect operation due to ignoring instruction will cause harm or damage. The seriousness is classified by the following indications.

⚠ WARNING This symbol indicates the possibility of death or serious injury.

⚠ CAUTION This symbol indicates the possibility of injury or damage to properties only.

- Meanings of symbols used in this manual are as shown below.



Be sure not to do.



Be sure to follow the instruction.

⚠ WARNING

■ Installation

Do not use a defective or underrated circuit breaker. Use this appliance on a dedicated circuit.

- There is risk of fire or electric shock.

For electrical work, contact the dealer, seller, a qualified electrician, or an Authorized Service Center.

- There is risk of fire or electric shock.

Always ground the unit.

- There is risk of fire or electric shock.

Install the panel and the cover of control box securely.

- There is risk of fire or electric shock.

Always install a dedicated circuit and breaker.

- Improper wiring or installation may cause fire or electric shock.

Use the correctly rated breaker or fuse.

- There is risk of fire or electric.

Do not modify or extend the power cable.

- There is risk of fire or electric shock.

Do not install, remove, or reinstall the unit by yourself (customer).

- There is risk of fire, electric shock, explosion, or injury.

For antifreeze, always contact the dealer or an authorized service center.

- Almost the antifreeze is a toxic product.

For installation, always contact the dealer or an Authorized Service Center.

- There is risk of fire, electric shock, explosion, or injury.

Do not install the unit on a defective installation stand.

- It may cause injury, accident, or damage to the unit.

Be sure the installation area does not deteriorate with age.

- If the base collapses, the unit could fall with it, causing property damage, unit failure, and personal injury.

Do not install the water pipe system as Open loop type.

- It may cause failure of unit.

Use a vacuum pump or inert (nitrogen) gas when doing leakage test or purging air. Do not compress air or oxygen and do not use flammable gases.

- There is the risk of death, injury, fire or explosion.

Make sure the connected condition of connector in product after maintenance.

- Otherwise, it may cause product damage.

Do not touch leaked refrigerant directly.

- There is risk of frostbite.

■ Operation

Take care to ensure that power cable could not be pulled out or damaged during operation.

- There is risk of fire or electric shock.

Do not place anything on the power cable.

- There is risk of fire or electric shock.

Do not plug or unplug the power supply plug during operation.

- There is risk of fire or electric shock.

Do not touch (operate) the unit with wet hands.

- There is risk of fire or electric shock.

Do not place a heater or other appliances near the power cable.

- There is risk of fire or electric shock.

Do not allow water to run into electric parts.

- There is risk of fire, failure of the unit, or electric shock.

Do not store or use flammable gas or combustibles near the unit.

- There is risk of fire or failure of unit.

Do not use the unit in a tightly closed space for a long time.

- It may cause damage to the unit.

When flammable gas leaks, turn off the gas and open a window for ventilation before turning the unit on.

- There is risk of explosion or fire.

If strange sounds, or small or smoke comes from unit, turn the breaker off or disconnect the power supply cable.

- There is risk of electric shock or fire.

Stop operation and close the window in storm or hurricane. If possible, remove the unit from the window before the hurricane arrives.

- There is risk of property damage, failure of unit, or electric shock.

Do not open the front cover of the unit while operation. (Do not touch the electrostatic filter, if the unit is so equipped.)

- There is risk of physical injury, electric shock, or unit failure.

Do not touch any electric part with wet hands. you should be power off before touching electric part.

- There is risk of electric shock or fire.

Do not touch refrigerant pipe and water pipe or any internal parts while the unit is operating or immediately after operation.

- There is risk of burns or frostbite, personal injury.

If you touch the pipe or internal parts, you should be wear protection or wait time to return to normal temperature.

- Otherwise , it may cause burns or frostbite, personal injury.

Turn the main power on 6 hours ago before the product starting operation.

- Otherwise, it may cause compressor damage.

Do not touch electric parts for 10 minutes after main power off.

- There is risk of physical injury, electric shock.

The inside heater of product may operate during stop mode. It is intended to protect the product.

Be careful that some part of the control box are hot.

- There is risk of physical injury or burns.

When the unit is soaked (flooded or submerged), contact an Authorized Service Center.

- There is risk of fire or electric shock.

Be cautious that water could not be poured to the unit directly.

- There is risk of fire, electric shock, or unit damage.

Ventilate the unit from time to time when operating it together with a stove, etc.

- There is risk of fire or electric shock.

Turn the main power off when cleaning or maintaining the unit.

- There is risk of electric shock.

Take care to ensure that nobody could step on or fall onto the unit.

- This could result in personal injury and unit damage.

For installation, always contact the dealer or an Authorized Service Center.

- There is risk of fire, electric shock, explosion, or injury.

If the unit is not used for long time, we strongly recommend not to switch off the power supply to the unit.

- There is risk of water freezing.

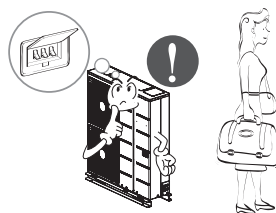

⚠ CAUTION**■ Installation**

Always check for gas (refrigerant) leakage after installation or repair of unit.

- Low refrigerant levels may cause failure of unit.

Keep level even when installing the unit.

- To avoid vibration or water leakage.

Use two or more people to lift and transport the unit.

- Avoid personal injury.

■ Operation

Do not use the unit for special purposes, such as preserving foods, works of art, etc.

- There is risk of damage or loss of property.

Use a soft cloth to clean. Do not use harsh detergents, solvents, etc.

- There is risk of fire, electric shock, or damage to the plastic parts of the unit.

Do not step on or put anything on the unit.

- There is risk of personal injury and failure of unit.

Use a firm stool or ladder when cleaning or maintaining the unit.





- Be careful and avoid personal injury.

Do not turn on the breaker or power under condition that front panel, cabinet, top cover, control box cover are removed or opened.

- Otherwise, it may cause fire, electric shock, explosion or death.

2. Installation Parts

Before starting installation, please make it sure that all parts are found inside the unit box.

Item	Image	Quantity
Installation Manual		1
Owner's Manual		1
Remote Controller		1
Cable		1

3. General Information

With advanced inverter technology, **THERMAV** is suitable for applications like under floor heating, under floor cooling, and hot water generation. By Interfacing to various accessories user can customize the range of the application.

In this chapter, general information of **THERMAV** is presented to identify the installation procedure. Before beginning installation, read this chapter carefully and find helpful information on installation.

Model Information

Model name and related information

Unit	Capacity		Power Source (Unit)	Chassis
	Heating (kW)*	Cooling (kW)**		
AHBW056A0	4.99	4.99	220-240 V~ 50 Hz	UN4
AHBW076A0	7.00	7.00	220-240 V~ 50 Hz	UN4
AHBW096A0	9.00	9.00	220-240 V~ 50 Hz	UN4
AHBW126A0	12.00	14.50	220-240 V~ 50 Hz	UN3
AHBW146A0	14.00	15.50	220-240 V~ 50 Hz	UN3
AHBW166A0	16.00	16.10	220-240 V~ 50 Hz	UN3
AHBW128A0	12.00	14.50	380-415 V ~50 Hz	UN3
AHBW148A0	14.00	15.50	380-415 V ~50 Hz	UN3
AHBW168A0	16.00	16.10	380-415 V ~50 Hz	UN3

* : tested under Eurovent Heating condition (inlet Water temperature 30 °C → 35 °C at outdoor ambient temperature 7 °C DB/ 6 °C WB)

** : tested under Eurovent Cooling condition (inlet Water temperature 23 °C → 18 °C at outdoor ambient temperature 36 °C DB/ 24 °C WB)

Components

AHBW056A0/AHBW076A0/AHBW096A0

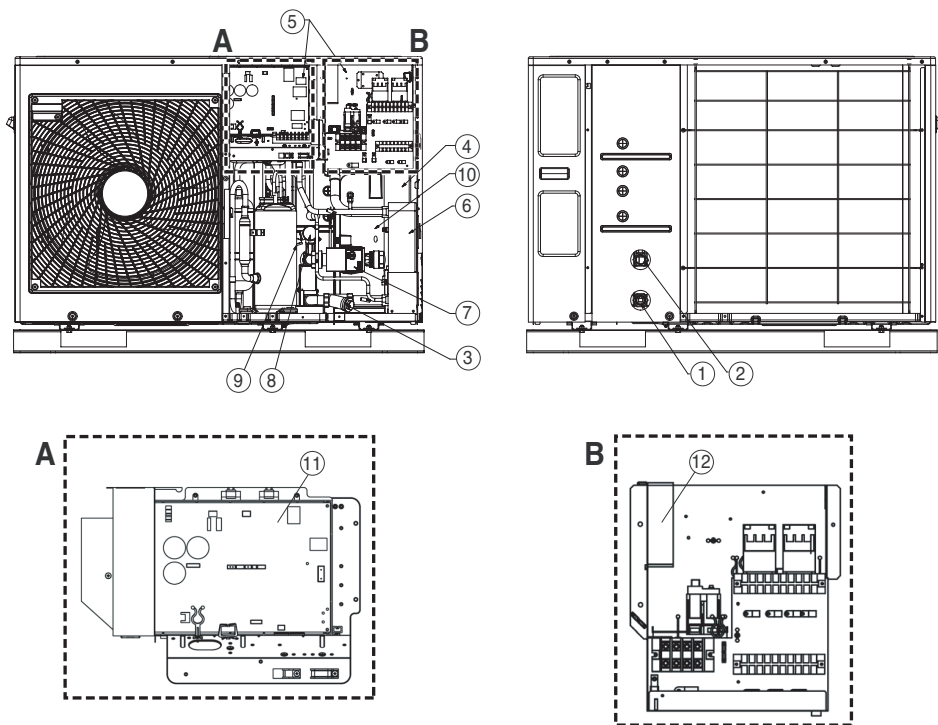

Description

No	Name	Remarks
1	Entering water pipe	PT 25.4mm(Female type)
2	Leaving water pipe	PT 25.4mm(Female type)
3	Strainer	Filtering and stacking particles inside circulating water
4	Electronic heater	Providing additional heating capacity to the water circuit
5	Control box	PCB and terminal blocks
6	Plate heat exchanger	Heat exchange between refrigerant and water
7	Water pump	Circulating the water
8	Pressure gage	Indicates circulating water pressure
9	Safety valve	Open at water pressure 3 bar
10	Expansion vassel	Protecting components from water pressure
11	Main PCB assembly(Inverter)	This PCB controls the cycle parts of the unit
12	Main PCB assembly(Heater)	This PCB controls the functioning of the unit

AHBW126A0/AHBW146A0/AHBW166A0

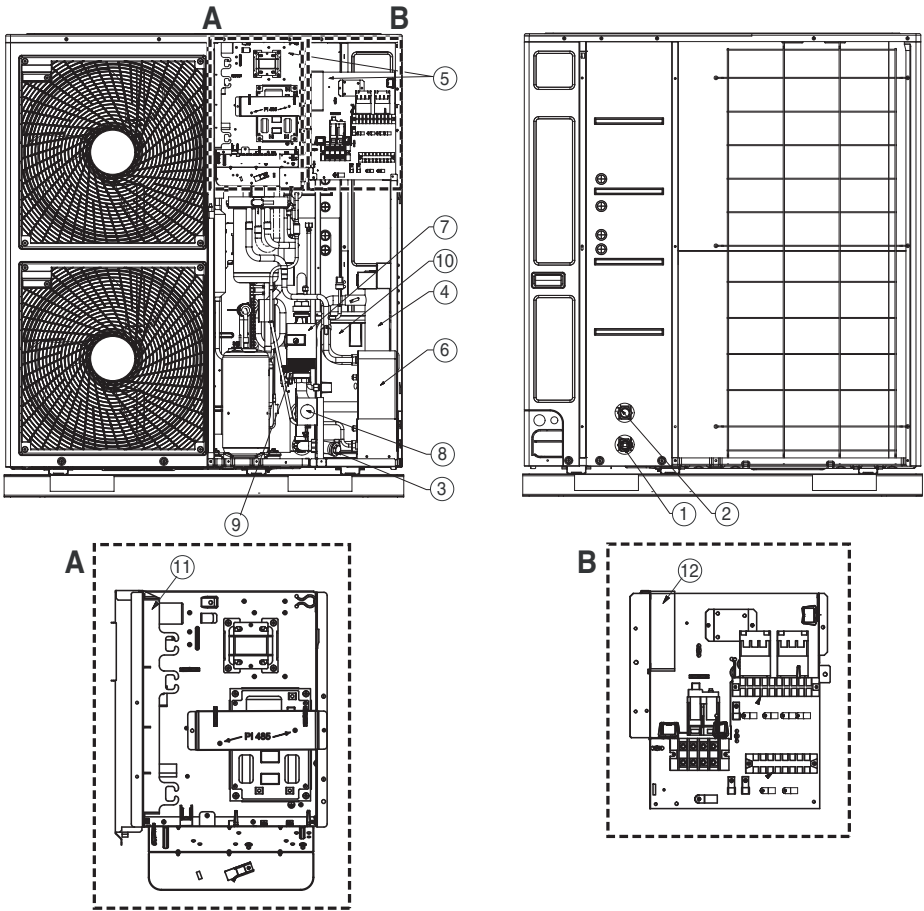

Description

No	Name	Remarks
1	Entering water pipe	PT 25.4mm(Female type)
2	Leaving water pipe	PT 25.4mm(Female type)
3	Strainer	Filtering and stacking particles inside circulating water
4	Electronic heater	Providing additional heating capacity to the water circuit
5	Control box	PCB and terminal blocks
6	Plate heat exchanger	Heat exchange between refrigerant and water
7	Water pump	Circulating the water
8	Pressure gage	Indicates circulating water pressure
9	Safety valve	Open at water pressure 3 bar
10	Expansion vassel	Protecting components from water pressure
11	Main PCB assembly(Inverter)	This PCB controls the cycle parts of the unit
12	Main PCB assembly(Heater)	This PCB controls the functioning of the unit

AHBW128A0/AHBW148A0/AHBW168A0

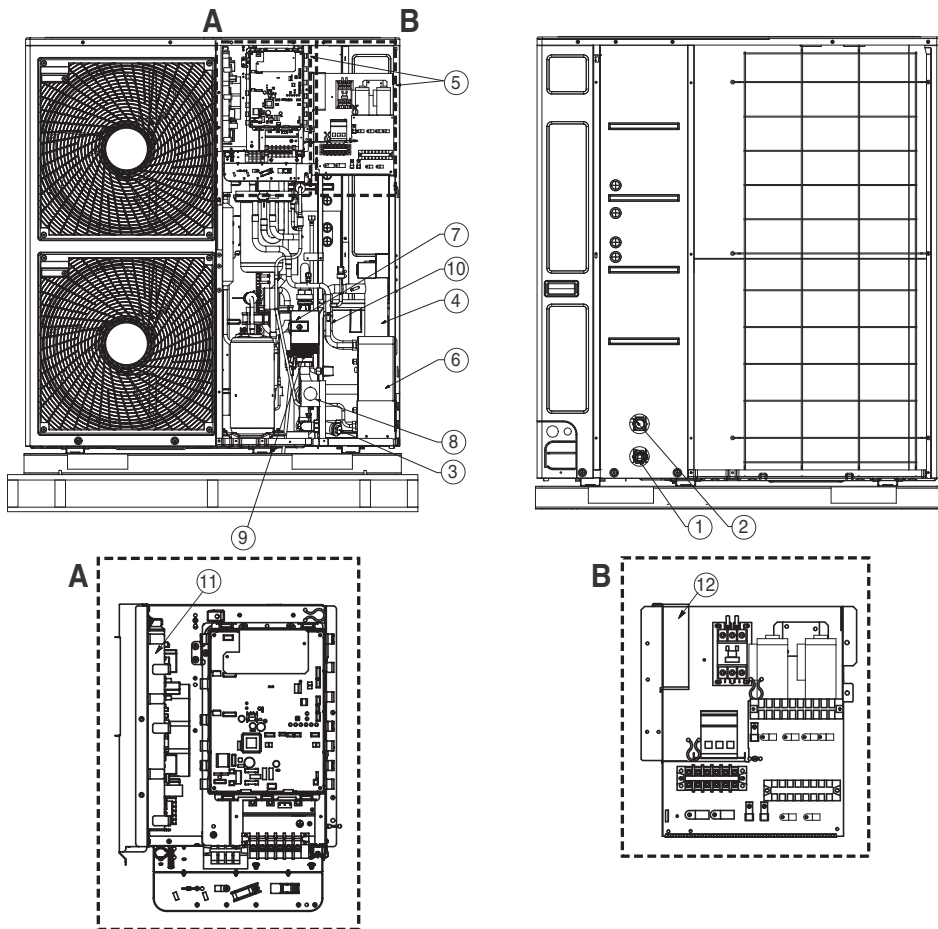

Description

No	Name	Remarks
1	Entering water pipe	PT 25.4mm(Female type)
2	Leaving water pipe	PT 25.4mm(Female type)
3	Strainer	Filtering and stacking particles inside circulating water
4	Electronic heater	Providing additional heating capacity to the water circuit
5	Control box	PCB and terminal blocks
6	Plate heat exchanger	Heat exchange between refrigerant and water
7	Water pump	Circulating the water
8	Pressure gage	Indicates circulating water pressure
9	Safety valve	Open at water pressure 3 bar
10	Expansion vassel	Protecting components from water pressure
11	Main PCB assembly(Inverter)	This PCB controls the cycle parts of the unit
12	Main PCB assembly(Heater)	This PCB controls the functioning of the unit

Accessories

To extend the functionality of **THERMAV**, there are various external auxiliary apparatus called as "accessories".

They are classified by "accessories" and "3rd party accessories" according to the manufacturer. Accessories are presented LG Electronics, and 3rd party accessories are presented by related manufacturers.

Accessories supported by LG Electronics

Item	Purpose	Model
Sanitary water tank kit	To operate with sanitary water tank	PHLTB
Remote air sensor	To control by air temperature	PQRSTA0
Dry contact	To receive on & off external signal	PQDSA
Sanitary water tank	To generate and store hot water	PHS02060310 : 200 liter, Single heating coil, 230 V~ 50 Hz 3 kW Electric heater PHS02060320 : 200 liter, Double heating coil, 230 V~ 50 Hz 3 kW Electric heater PHS03060310 : 300 liter, Single heating coil, 230 V~ 50 Hz 3 kW Electric heater PHS03060320 : 300 liter, Double heating coil, 230 V~ 50 Hz 3 kW Electric heater

Accessories supported by 3rd party Companies

Item	Purpose	Specification
Thermostat	To control by air temperature	Heating-Only type (230 V~) Cooling / Heating type (230 V~ with mode selection switch)
3way valve and actuator	To control water flow for hot water heating or floor heating	3 wire, SPDT (Single Pole Double Throw) type, 230 V~
2way valve and actuator	To control water flow for Fan Coil Unit	2 wire,NO(Normal Open) or NC(Normal Closed) type, 230 V~
Solar Heating System	To generate auxillary heating energy for water tank	

4. Installation

Transporting the Unit

- When carrying the suspended unit, pass the ropes between legs of base panel under the unit.
- Always lift the unit with ropes attached at four points so that impact is not applied to the unit.
- Attach the ropes to the unit at an angle \textcircled{A} of 40° or less.
- Use only accessories and parts which are of the designated specification when installing.

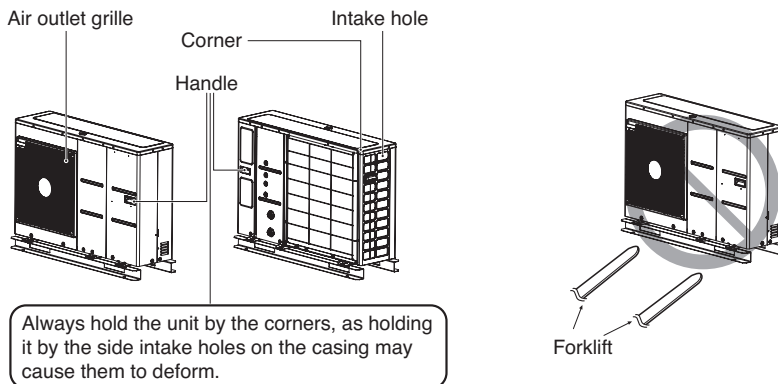
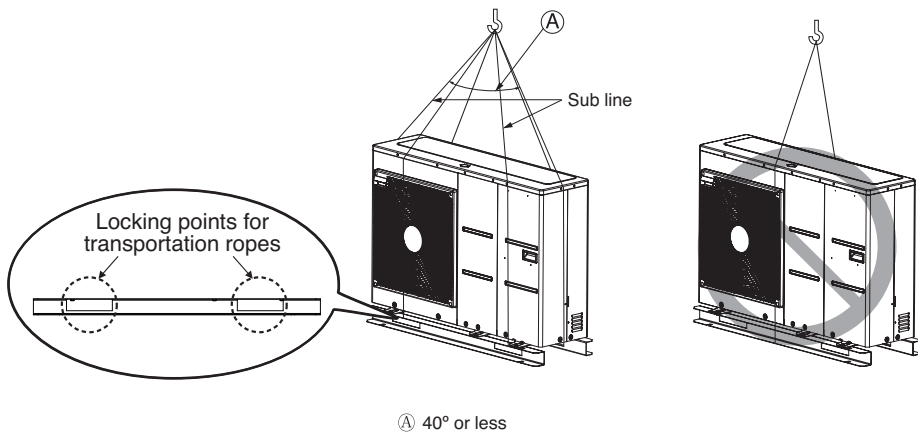

⚠ CAUTION

Be very careful while carrying the unit.

- Do not have only one person carry the unit if it is more than 20 kg (44.1 lbs).
- PP bands are used to pack some products. Do not use them as a mean for transportation because they are dangerous.
- Do not touch heat exchanger fins with your bare hands. Otherwise you may get a cut in your hands.
- Tear plastic packaging bag and scrap it so that children cannot play with it. Otherwise plastic packaging bag may suffocate children to death.
- When carrying the unit, be sure to support it at 4-points. Carrying and lifting the unit with 3-point support may make it unstable, resulting in a fall.

Selection of The Best Location

1. Select space for installing unit, which will meet the following conditions:
 - No direct thermal radiation from other heat sources
 - No possibility of annoying neighbors by noise from unit
 - No exposition to strong wind
 - With strength which bears weight of unit
 - Note that drain flows out of unit when heating
 - With space for air passage and service work shown next
 - Because of the possibility of fire, do not install unit to the space where generation, inflow, stagnation, and leakage of combustible gas is expected.
 - Avoid unit installation in a place where acidic solution and spray (sulfur) are often used.
 - Do not use unit under any special environment where oil, steam and sulfuric gas exist.
 - It is recommended to fence round the unit in order to prevent any person or animal from accessing the unit.
 - If installation site is area of heavy snowfall, then the following directions should be observed.
 - Make the foundation as high as possible.
 - Fit a snow protection hood.
2. Select installation location considering following conditions to avoid bad condition when additionally performing defrost operation.
 - Install the unit at a place well ventilated and having a lot of sunshine in case of installing the product at a place with a high humidity in winter (near beach, coast, lake, etc). (Ex) Rooftop where sunshine always shines.
 - Performance of heating will be reduced and preheat time of the unit may be lengthened in case of installing the unit in winter at following location:
 - Shade position with a narrow space
 - Location with much moisture in neighboring floor.
 - Location with much humidity around.
 - Location where ventilation is good.It is recommended to install the unit at a place with a lot of sunshine as possible as.
 - Location where water gathers since the floor is not even.
3. When installing the unit in a place that is constantly exposed to a strong wind like a coast or on a high story of a building, secure a normal fan operation by using a duct or a wind shield.
 - Install the unit so that its discharge port faces to the wall of the building. Keep a distance 300mm or more between the unit and the wall surface.
 - Supposing the wind direction during the operation season of the air conditioner, install the unit so that the discharge port is set at right angle to the wind direction.

Installation Conditions

General considerations

- If a sunroof is built over the unit to prevent direct sunlight or rain exposure, make sure that heat radiation from the heat exchanger is not restricted.
- Ensure that the spaces indicated by arrows around front, back and side of the unit.
- Do not place animals and plants in the path of the warm air.
- Take the weight of the unit into account and select a place where noise and vibration are minimum.
- Select a place so that the warm air and noise from the unit do not disturb neighbors.
- The surface of the ground or the structure must be strong enough to bear the weight of the unit.

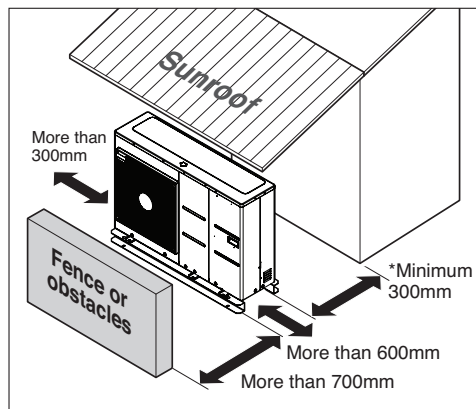

* : Please secure the space to install the shut-off valve and strainer.

Installation at Seaside

⚠ CAUTION

1. Unit should not be installed in areas where corrosive gases, such as acid or alkaline gas, are produced.
2. Do not install the unit where it could be exposed to sea wind (salty wind) directly. It can result corrosion on the unit. Corrosion, particularly on the condenser and evaporator fins, could cause unit malfunction or inefficient performance.
3. If unit is installed close to the seaside, it should avoid direct exposure to the sea wind. Otherwise it needs additional anticorrosion treatment on the heat exchanger.

Selecting the location

- 1) If the unit is to be installed close to the seaside, direct exposure to the sea wind should be avoided. Install the unit on the opposite side of the sea wind direction.

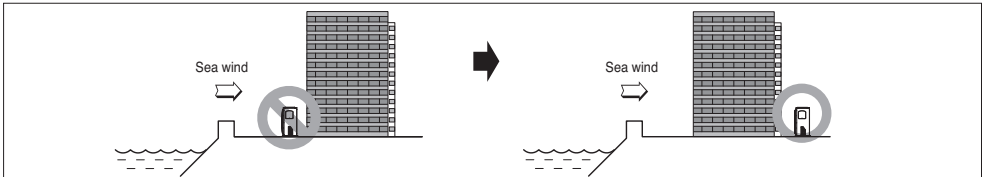

- 2) In case, to install the unit on the seaside, set up a windbreak not to be exposed to the sea wind.

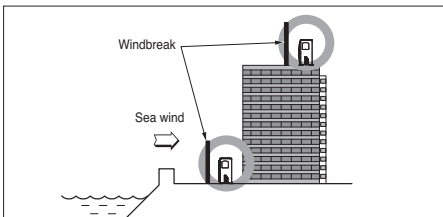

- It should be strong enough like concrete to prevent the sea wind from the sea.
- The height and width should be more than 150% of the unit.
- It should be keep more than 700 mm of space between unit and the windbreak for easy air flow.

- 3) Select a well-drained place.

1. If you can't meet above guide line in the seaside installation, please contact your supplier for the additional anticorrosion treatment.
2. Periodic (more than once/year) cleaning of the dust or salt particles stuck on the heat exchanger by using water

Seasonal Wind and Cautions in Winter

- Sufficient measures are required in a snow area or severe cold area in winter so that unit can be operated well.
- Get ready for seasonal wind or snow in winter even in other areas.
- Install a suction and discharge duct not to let in snow or rain.
- Install the unit not to come in contact with snow directly. If snow piles up and freezes on the air suction hole, the system may malfunction. If it is installed at snowy area, attach the hood to the system.
- Install the unit at the higher installation console by 500mm than the average snowfall (annual average snowfall) if it is installed at the area with much snowfall.
- Where snow accumulated on the upper part of the unit by more than 100mm, always remove snow for operation.

1. The height of H frame must be more than 2 times the snowfall and its width shall not exceed the width of the unit. (If width of the frame is wider than that of the unit, snow may accumulate.)
2. Don't install the suction hole and discharge hole of the unit facing the seasonal wind.

Foundation for Installation

- Check the strength and level of the installation ground so that the unit will not cause any operating vibration or noise after installation.
- Fix the unit securely by means of the foundation bolts. (Prepare 4sets of M12 foundation bolts, nuts and washers each which are available on the market.)
- It is best to screw in the foundation bolts until their length are 20mm from the foundation surface.

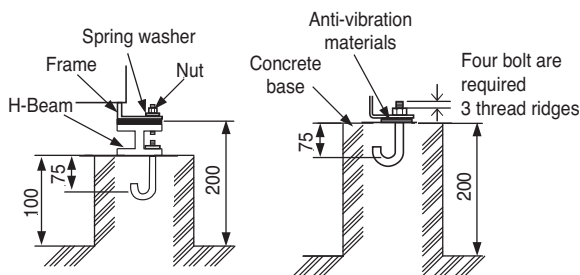
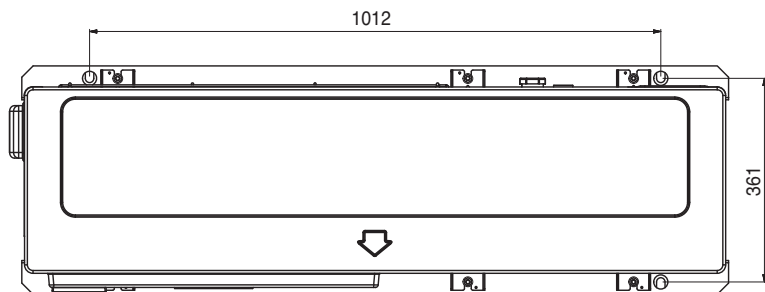

[Unit:mm]

Foundation bolt executing method

⚠ WARNING

- Be sure to remove the Pallet(Wood Support) of the bottom side of the unit Base Pan before fixing the bolt. It may cause the unstable state of the unit settlement, and may cause freezing of the heat exchanger resulting in abnormal operations.
- Be sure to remove the Pallet(Wood Support) of the bottom side of the unit before welding. Not removing Pallet(Wood Support) causes hazard of fire during welding.

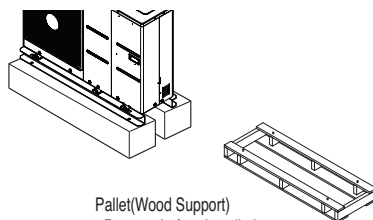

Pallet(Wood Support)
- Remove before Installation

Installation Scenes

⚠ CAUTION

If is installed with pre-existing boiler, the boiler and **THERMAV** should not be operated together. If entering water temperature of **THERMAV** is above 55 °C, the system will stop operation to prevent mechanical damage of the unit. For detailed electric wiring and water piping, please contact authorized installer.

Some installation scenes are presented for example. As these scenes are conceptual figures, installer should optimize the installation scene according to the installation conditions.





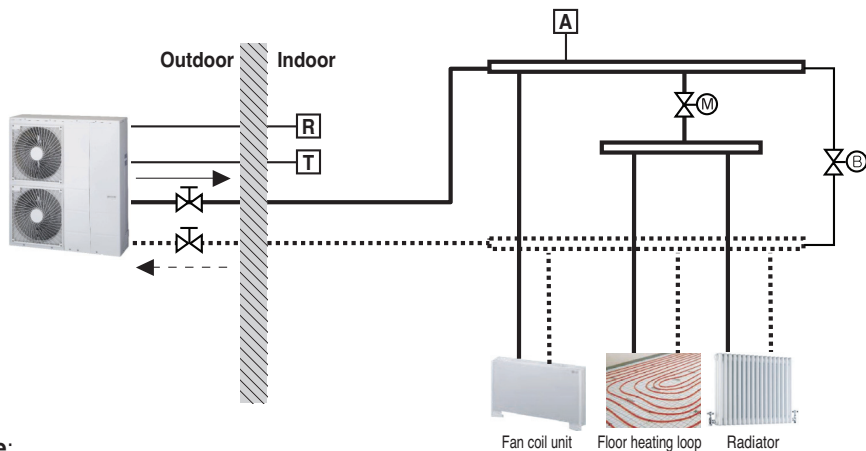

CASE 1: Connecting heat emitters for heating and cooling

(Under floor loop, Fan coil unit, and Radiator)



Note:

- Room thermostat
 - Type of thermostat and specification should be complied with chapter 5 of the installation manual.
- 2way valve
 - It is important to install 2way valve to prevent dew condensation on the floor and radiator while cooling mode.
 - Type of 2way valve and specification should be complied with chapter 5 of the installation manual.
 - 2way valve should be installed at the supply side of the collector.
- By-pass valve
 - To secure enough water flow rate, by-pass valve should be installed at the collector.
 - By-pass valve should guarantee minimum water flow rate in any case. Minimum water flow rate is described in water pump characteristics curve.

	Room thermostat(field supply)		By-pass valve(field supply)		Air vent
	2way valve (field supply)		Remote controller		Shut-off valve(field supply)
	Strainer (Mesh: 1 mm x 1 mm)				

CASE 2: Connecting sanitary water tank

(Under floor loop, Fan coil unit, and Radiator)

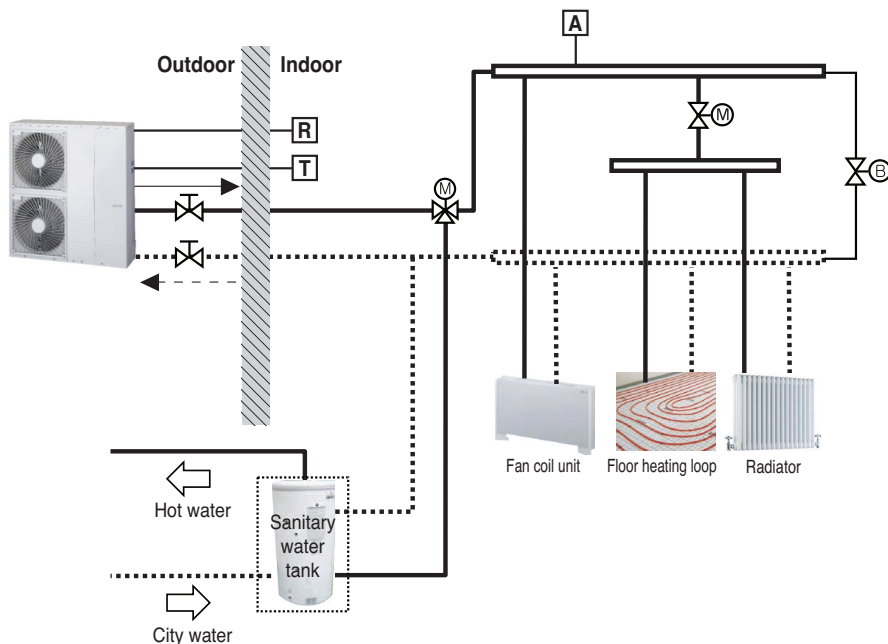

Note:

- Sanitary water tank
 - It should be equipped with internal electric heater to generate sufficient heat energy in very cold season.
- 3way valve
 - Type of 3way valve and specification should be complied with chapter 5 of the installation manual.

	Air vent		By-pass valve(Field supply)		Remote controller
	Room thermostat(Field supply)		3way valve (Field supply)		Shut-off valve(field supply)
	2way valve (Field supply)				

CASE 3: Connecting Solar thermal system

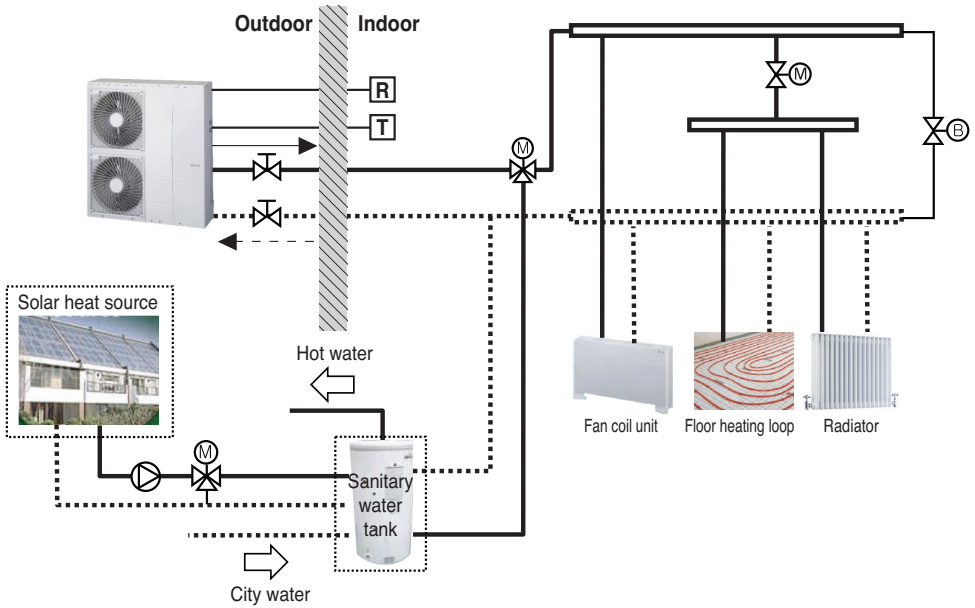

Note:

- Sanitary water tank
 - It should have additional indirect heat exchanger to utilize heat energy by solar thermal system.
- Pump
 - Maximum power consumption of pump should be less than 0.25kW.

	Pump(Field supply)		By-pass valve(Field supply)		Remote controller
	Room thermostat(Field supply)		3way valve (Field supply)		Shut-off valve(field supply)
	2way valve (Field supply)				

Water Piping and Water Circuit Connection

General considerations

Followings are should be considered before beginning water circuit connection.

- Service space should be secured.
- Water pipes and connections should be cleaned using water.
- Space for installing external water pump should be provided if internal water pump capacity is not enough for installation field.
- Never connect electric power while proceeding water charging.

Water piping and water circuit connection

Definition of terms are as follow :

- Water piping : Installing pipes where water is flowing inside the pipe.
- Water circuit connecting : Making connection between the unit and water pipes or between pipes and pipes. Connecting valves or elbows are, for example, in this category.

Configuration of water circuit is shown in Chapter 4 "Installation Scenes". All connections should be complied with presented diagram.

While installing water pipes, followings should be considered :

- While inserting or putting water pipes, close the end of the pipe with pipe cap to avoid dust entering.
- When cutting or welding the pipe, always be careful that inner section of the pipe should not be defective. For example, no weldments or no burrs are found inside the pipe.
- Drain piping should be provided in case of water discharge by the operation of the safety valve. This situation can be happened when the internal pressure is over 3.0 bar and water inside the unit will be discharged to drain hose.
- Pipe fittings (e.g. L-shape elbow, T-shape tee, diameter reducer, etc) should be tightened strongly to be free from water leakage.
- Connected sections should be leakage-proof treatment by applying teflon tape, rubber bushing, sealant solution, etc.
- Appropriate tools and tooling methods should be applied to prevent mechanical breakage of the connections.
- Operation time of flow valve(e.g. 3way valve or 2way valve) should be less than 90 seconds.
- While supplying water, pressure of supplying water should be 2.0 bar approximately.
- Pipe is insulated to prevent heat loss to external environment and to prevent dew generation on the surface of the pipe in cooling operation.

When the water pipes are connected.
It must be tightened the nut with two wrench.
Otherwise pipes can be deformed.

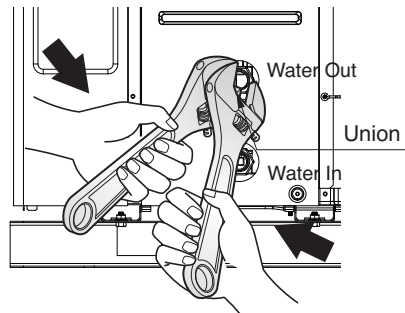

⚠ WARNING

Water condensation on the floor

While cooling operation, it is very important to keep leaving water temperature higher than 16 °C. Otherwise, dew condensation can be occurred on the floor.

If floor is in humid environment, do not set leaving water temperature below 18 °C.

Water condensation on the radiator

While cooling operation, cold water may not flow to the radiator. If cold water enters to the radiator, dew generation on the surface of the radiator can be occurred.

Drainage treatment

While cooling operation, condensed dew can drop down to the bottom of the unit. In this case, prepare drainage treatment (for example, vessel to contain condensed dew) to avoid water drop.

Water Pipe Insulation

Purpose of water pipe insulation is :

To prevent heat loss to external environment.

To prevent dew generation on the surface of the pipe in cooling operation.

To prevent pipe breakage by freeze at winter season,

※ Must be insulation at exterior water pipe between product and building.

Shutoff Valve

- Shut-Off Valve is used to connect water pipe to unit.
- Tighten the flare nut with two spanner. (check the leak to the connection.)

Water volume and pump capacity

The water pump is three speed-adjustable (Maximum / Medium / Minimum), so it may be required to change default water pump speed in case of noise by water flow. In most case, however, it is strongly recommended to set speed as Maximum.

ⓘ NOTICE

Water pump speed

To secure enough water flow rate, do not set water pump speed as "Min."

It can lead unexpected flow rate error CH14.

Product Heating Capacity: 5kw

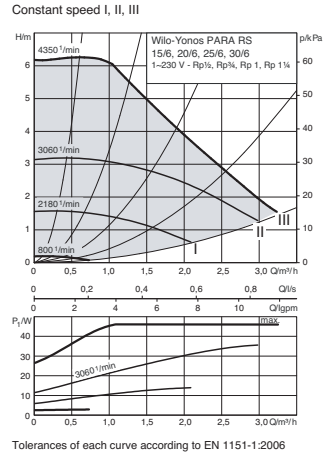
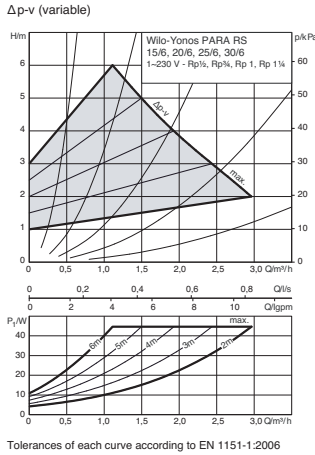

Product Heating Capacity: 7, 9kw

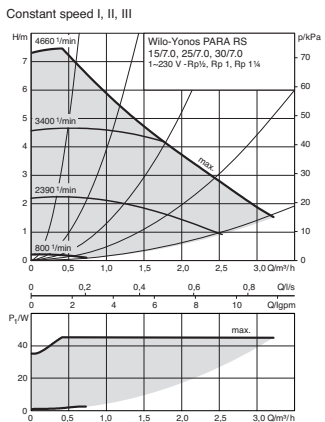
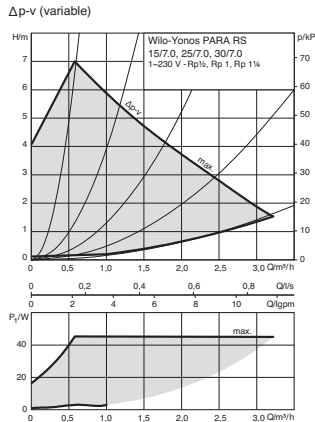

Product Heating Capacity: 12, 14, 16kw

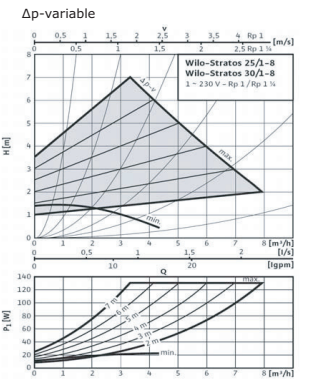
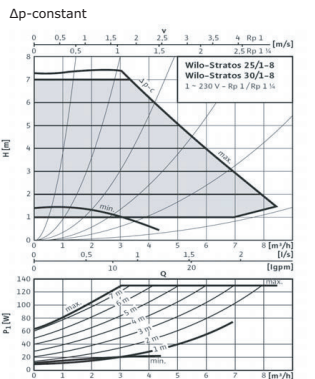

Max. : high speed setting, Med. : low speed setting

Warning : Selecting a water flowrate outside the curves can cause damage to or malfunction of the unit.

: Operation cutoff range

Water quality

Water quality should be complied with EN 98/83 EC Directives. Requirement for resolved chemical ingredients is following table. Detailed water quality condition can be found in EN 98/83 EC Directives.

Parameter	Value	Parameter	Value
Acrylamide	0.10 $\mu\text{g/l}$	Fluoride	1.5 mg/l
Antimony	5.0 $\mu\text{g/l}$	Lead	10 $\mu\text{g/l}$
Arsenic	10 $\mu\text{g/l}$	Mercury	1.0 $\mu\text{g/l}$
Benzene	1.0 $\mu\text{g/l}$	Nickel	20 $\mu\text{g/l}$
Benzo(a)pyrene	0.010 $\mu\text{g/l}$	Nitrate	50 mg/l
Boron	1.0 mg/l	Nitrite	0.50 mg/l
Bromate	10 $\mu\text{g/l}$	Pesticides	0.10 $\mu\text{g/l}$
Cadmium	5.0 $\mu\text{g/l}$	Pesticides — Total	0.50 $\mu\text{g/l}$
Chromium	50 $\mu\text{g/l}$	Polycyclic aromatic hydrocarbons	0.10 $\mu\text{g/l}$
Copper	2.0 mg/l	Selenium	10 $\mu\text{g/l}$
Cyanide	50 $\mu\text{g/l}$	Tetrachloroethene and Trichloroethene	10 $\mu\text{g/l}$
1,2-dichloroethane	3.0 $\mu\text{g/l}$	Trihalomethanes — Total	100 $\mu\text{g/l}$
Epichlorohydrin	0.10 $\mu\text{g/l}$	Vinyl chloride	0.50 $\mu\text{g/l}$

CAUTION

- If the unit is installed at existing hydraulic water loop, it is important to clean hydraulic pipes to remove sludge and scale.
- Installing sludge strainer in the water loop is very important to prevent performance degrade.
- Chemical treatment to prevent rust should be performed by installer.

Frost protection

In areas of the country where entering water temperatures drop below 0 °C, the water pipe must be protected by using an approved antifreeze solution. Consult your AWHP unit supplier for locally approved solutions in your area. Calculate the approximate volume of water in the system. (Except the AWHP unit.) And add six liters to this total volume to allow for the water contained in AWHP unit.

Antifreeze type	Antifreeze mixing ratio					
	0°C	-5°C	-10°C	-15°C	-20°C	-25°C
Ethylene glycol	0%	12%	20%	30%	-	-
Propylene glycol	0%	17%	25%	33%	-	-
Methanol	0%	6%	12%	16%	24%	30%

CAUTION

1. Use only one of the above antifreeze.
2. If a antifreeze is used, pressure drop and capability degradation of the system can be occurred.
3. If one of antifreezes is used, corrosion can be occurred. So please add corrosion inhibitor.
4. Please check the concentration of the antifreeze periodically to keep same concentration.
5. When the antifreeze is used (for installation or operation), take care to ensure that antifreeze must not be touched.
6. Ensure to respect all laws and norms of your country about Anti-freeze usage.

Water Volume and Expansion Vessel Pressure

Expansion vessel should be installed in the water circuit to protect components from water pressure.

- Minimum total water volume is 20 liter. (In special case, extra water volume might be required.)
- Pre-pressure is adjusted by the total water volume. If the unit is located at the highest position of the water circuit, adjustment is not required.
- To adjust pre-pressure, use nitrogen gas by certificated installer.

Example) Expansion vessel of 8 liter capacity

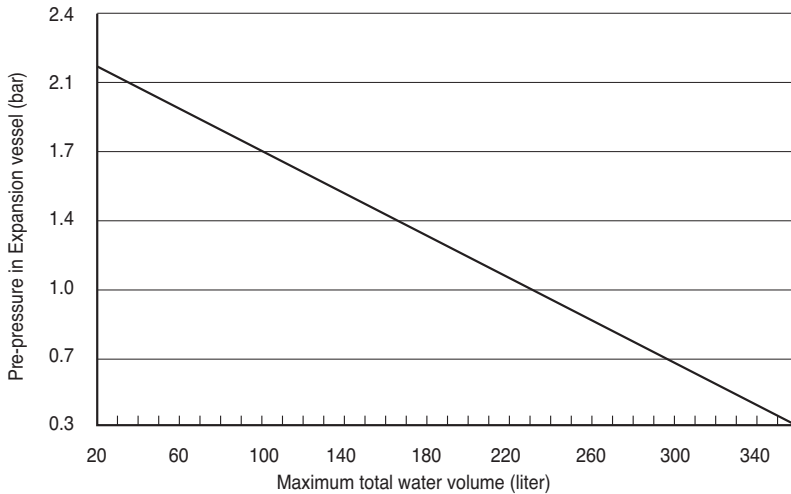

Adjusting pre-pressure of expansion vessel is as following :

Step 1. Refer "Volume-Height" table.

If installation scene is belong to Case A, go to Step 2.

Otherwise, if it is Case B, do nothing. (pre-pressure adjustment is not required.)

Otherwise, if it is Case C, go to Step 3.

Step 2. Adjust pre-pressure by following equation.

Pre-pressure [bar] = $(0.1 \cdot H + 0.3)$ [bar] where H : difference between unit and the highest water pipe
0.3 : minimum water pressure to secure unit operation

Step 3. Volume of expansion vessel is less than installation scene.

Please install additional expansion vessel at the external water circuit.

Volume-Height Table

	V < 230 liter	V ≥ 230 liter
H < 7 m	Case B	Case A
H ≥ 7 m	Case A	Case C

H : difference between unit and the highest water pipe

V : total water volume of installation scene

Electrical Wiring

1. Follow ordinance of your governmental organization for technical standard related to electrical equipment, wiring regulations and guidance of each electric power company.

WARNING

Be sure to have authorized electrical engineers do the electric work using special circuits in accordance with regulations and this installation manual. If power supply circuit has a lack of capacity or electric work deficiency, it may cause an electric shock or fire.

2. Install the Unit transmission line away from the power source wiring so that it is not affected by electric noise from the power source. (Do not run it through the same conduit.)
3. Be sure to provide designated grounding work to Unit.

CAUTION

Be sure to correct the unit to earth. Do not connect earth line to any gas pipe, liquid pipe, lightning rod or telephone earth line. If earth is incomplete, it may cause an electric shock.

4. Give some allowance to wiring for electrical part box of Units, because the box is sometimes removed at the time of service work.
5. Never connect the main power source to terminal block of transmission line. If connected, electrical parts will be burnt out.
6. Only the transmission line specified should be connected to the terminal block for Unit transmission.

CAUTION

- **This product have reversed phase protection detector that only works when the power is turned on. If there exists black out or the power goes on and off which the product is operating, attach a reversed phase protection circuit locally. running the product in reversed phase may break the compressor and other parts.**
- **Use the 2-core shield cables for communication lines. Never use them together with power lines.**
- **The conductive shielding layer of cable should be grounded to the metal part of both units.**
- **Never use multi-core cable**
- **As this unit is equipped with an inverter, to install a phase leading capacitor not only will deteriorate power factor improvement effect, but also may cause capacitor abnormal heating. Therefore, never install a phase leading capacitor.**
- **Make sure that the power unbalance ratio is not greater than 2%. If it is greater, the unit's lifespan will be reduced.**
- **Introducing with a missing N-phase or with a mistaken N-phase will break the equipment**

◆ Wire specification

Power cable specification : The power cord connected to the unit should be complied with IEC 60245 or HD 22.4 S4 (Rubber insulated cord, type 60245 IEC 66 or H07RN-F)

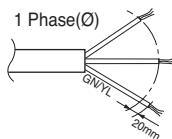

If the supply cord is damaged, it must be replaced by the manufacturer, its service agent or similarly qualified persons in order to avoid a hazard.

Terminal specification of power cable and related cautions :

Use round pressure terminals for connections to the power terminal block.

* Should be used round pressure terminals when connecting the ground at control box panel.

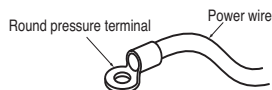

If do not use any materials when connecting cables to terminal block, follow the instructions below.

- Do not connect wiring of different thicknesses to the power terminal block. (Slack in the power wiring may cause abnormal heat.)
- When connecting wiring which is the same thickness, do as shown in the figure below.

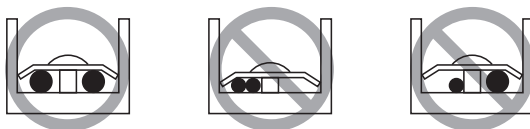

Connecting Cables

General consideration

Followings should be considered before beginning unit wiring.

- Field-supplied electrical components such as power switches, circuit breakers, wires, terminal boxes, etc should be properly chosen with compliance with national electrical legislation or regulation.
- Make it sure that supplied electricity is enough to operate the unit, electric heater, water tank heater, etc. The capacity of fuse also selected according to the power consumption.
- The main electricity supply should be dedicated line. Sharing main electricity supply with other devices such as washing machine or vacuum cleaner is not permitted.

⚠ CAUTION

- Before starting wiring job, the main electricity supply should be turned off until wiring is completed.
- When adjusting or changing wiring, the main electricity supply should be turned off and ground wire should be connected securely.
- Installation place should be free from the attack of wild animal. For example, mice's wire attacking or frog's entering into the unit may cause critical electrical accident.
- All power connections should be protected from dew condensation by thermal insulation.
- All electrical wiring should comply with national or local electrical legislation or regulation.
- The ground should be connected exactly. Do not earth the unit to the copper pipe, steel fence at the veranda, city water outlet pipe, or any other conductivity materials.
- Fix all cable using cord clamp tightly. (When cable is not fixed with cord clamp, use additionally supplied cable ties.)

Types of the cables

Power supply cable (Include earth)	Unit (spec)	AHBW056A0/076A0/096A0	AHBW126A0/146A0/166A0	AHBW128A0/148A0/168A0
Unit	No *mm ² (H07RN-F)	3 * 1.5	3 * 2.5	5 * 1.0
Heater	No *mm ² (H07RN-F)	3 * 2.5	3 * 4.0	5 * 1.5

Safety Breaker

Current Recommended Fuses	AHBW056A0/076A0/096A0	AHBW126A0/146A0/166A0	AHBW128A0/148A0/168A0
A	20	40	20

⚠ WARNING

- Earth should be connected.
- If grounding is not properly done, there is a risk of electric shock. Grounding must be done by a qualified technician.
- Consider the surrounding conditions(surrounding temperature, direct sunlight, rain water, etc.) when wiring the cable.
- The thickness of the power cable is the minimum thickness of metal conductor cable. Use thicker cable considering the voltage drop.

Wiring procedure for power cable

This cable is generally connected between external power source (such as main electric power distribution panel of user's house) and the unit. Before starting wiring, check if wire specification is suitable and read following directions and cautions VERY carefully.

Step 1. : Disassemble side panel and front panel from the unit by losing screws.

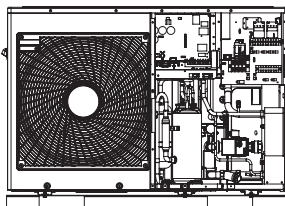

(AHBW056A0/AHBW076A0/AHBW096A0)

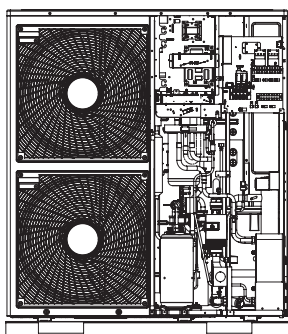

(AHBW126A0/AHBW146A0/AHBW166A0)

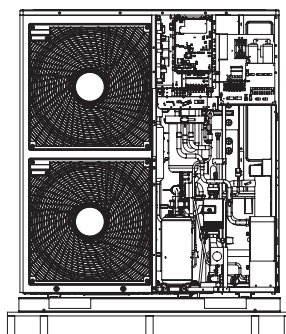

(AHBW128A0/AHBW148A0/AHBW168A0)

Step 2. : Connect power cable to main power terminal

See below figure for detailed information. When connecting earth cable, the diameter of cable should refer to the below table. The earth cable is connected to the Control box case where earth symbol is \oplus marked.

Step 3. : Use cable clamps (or cord clamps) to prevent unintended move of power cable.

Step 4. : Reassemble the side panel to the unit by fastening screws.

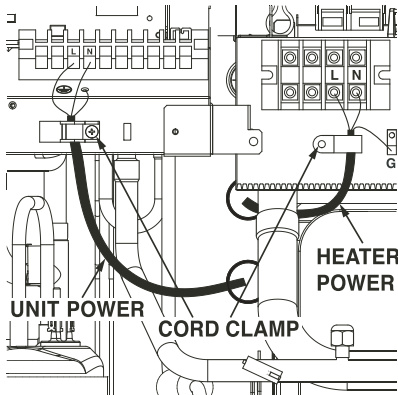

(AHBW056A0/AHBW076A0/AHBW096A0)

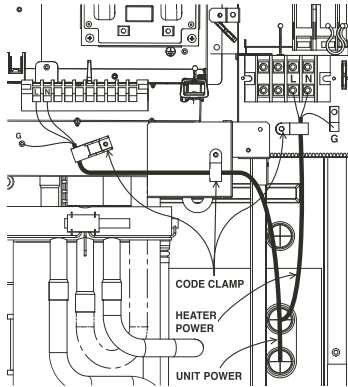

(AHBW126A0/AHBW146A0/AHBW166A0)

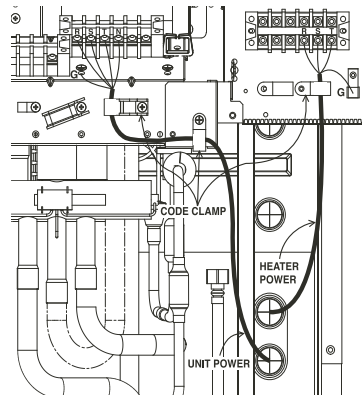

(AHBW128A0,AHBW148A0,AHBW168A0)

Failure to do these instruction can result in fire, electric shock or death.

- Make sure the power cable do not touch to copper tube.
- Make sure to fix [cord clamp] firmly to sustain the connection of terminal.
- Make sure to connect unit power & heater power separately.

Terminal block information

Symbols used below pictures are as follows :

- L, L1, L2 : Live (220-240 V~ 50 Hz)
- N : Neutral (220-240 V~ 50 Hz)
- BR : Brown , WH : White , BL : Blue , BK : Black, GR/YL : Green/Yellow

Terminal block 1

energizing water pump for solar thermal system

water flow switching between under floor heating and sanitary water tank heating

3WAY VALVE (B)			WATER PUMP (B)		WATER TANK HEATER		3WAY VALVE (A)		
1 L	2 L1	3 N	4 L	5 N	6 L	7 N	8 L	9 L1	10 N
BR	BK	BL	BR	BL	BR	BL	BR	BK	BL

water flow switching between using solar thermal heating and skipping solar thermal heating

turn on or off sanitary water tank heater

Terminal block 2

opening or closing water flow for FCU cooling

2WAY VALVE (A)			THERMOSTAT (Default : 230V AC)			
11	12	13	14	15	16	17
L1	L2	N	L	N	L1	L2
BR	BK	BL	BR	BL	BR	BK

Connection for thermostat (230V~)
Supporting type : Heating only or Heating/Cooling

Terminal block 3

AHBW**6A0(1 Phase)

		EXTERNAL POWER (W/TNK E/HEATER)	
		3	4
		L	N
		BR	BL

connecting external electric power supply for internal electric heater

AHBW**8A0(3 Phase)

			EXTERNAL POWER (INTERNAL E/HEATER)		
1	2		3	4	5
			R	S	T
			BR	BK	GY

connecting external electric power supply for internal electric heater

⚠ CAUTION

The power cord connected to the unit should be selected according to the following specifications.

Circuit breaker specification

- Select a power source that is capable of supplying the current required by the unit.
- Use a recognized circuit breaker between the power source and the unit.
A disconnection device to adequately disconnect all supply lines must be fitted.
- Capacity of circuit breaker recommended.
- Separate main power supply and heater supply.

Model	Power supply	Core Component Electrical Spec								MCA & MOP					
		Compressor		Electric Heater		Sanitary Tank Heater				For unit		For electric heater (Without S/Heater)		For electric heater (With S/Heater)	
		RLA (A)	FLA (A)	Capacity (kW)	Power Supply	RLA (A)	Capacity (kW)	Power Supply	FLA (A)	MCA (A)	MOP (A)	MCA (A)	MOP (A)	MCA (A)	MOP (A)
AHBW056A0	220-240 V~ 50 Hz	9.7	15	2+2	1 Ø	8.3	3	230 V~	12.5	14.2	23.9	18.7	27	32.2	44.7
AHBW076A0		9.7	15	2+2											
AHBW096A0		9.7	15	2+2											
AHBW126A0		17	27	3+3		12.5									
AHBW146A0		17	27	3+3											
AHBW166A0		17	27	3+3											
AHBW128A0	380-415 V~ 50Hz	5.3	9.9	2+2+2	3 Ø	8.7	8	14	12	22	21	38			
AHBW148A0		5.3	9.9	2+2+2											
AHBW168A0		5.3	9.9	2+2+2											

- S/Heater : Sanitary water tank heater
- FLA : Full load ampere
- MOP : Maximum rating of overcurrent protective device

CAUTION

After checking and confirming following conditions, start wiring work.

1. Secure dedicated power source for the Air-to-Water heat pump. The wiring diagram (attached inside the panel of the unit) is presenting related information.
2. Provide a circuit breaker switch between power source and the unit.
3. Although it is very rare case, sometimes the screws used to fasten internal wires can be loosen due to the vibration while unit transportation. Check these screws and make it sure if they are all fastened tightly. If not tightened, burn-out of the wire can be occurred.
4. Check the specification of power source such as phase, voltage, frequency, etc.
5. Confirm that electrical capacity is sufficient.
6. Be sure that the starting voltage is maintained at more than 90 percent of the rated voltage marked on the name plate.
7. Confirm that the cable thickness is as specified in the power sources specification. (Particularly note the relation between cable length and thickness.)
8. Provide an ELB(electric leakage breaker) when the installation place is wet or moist.
9. The following troubles would be caused by abnormal voltage supply such as sudden voltage increasing or voltage drop-down.
 - Chattering of a magnetic switch (frequent on and off operation)
 - Physical damage of parts where magnetic switch is contacted
 - Break of fuse
 - Malfunction of overload protection parts or related control algorithms.
 - Failure of compressor start up

Wiring of main power supply and equipment capacity

1. Use a separate unit power and heater power.
2. Bear in mind ambient conditions (ambient temperature, direct sunlight, rain water, etc.) when proceeding with the wiring and connections.
3. The wire size is the minimum value for metal conduit wiring. The power cord size should be 1 rank thicker taking into account the line voltage drops. Make sure the power-supply voltage does not drop more than 10%.
4. Specific wiring requirements should adhere to the wiring regulations of the region.
5. Power supply cords of parts of appliances for unit use should not be lighter than polychloroprene sheathed flexible cord.
6. Don't install an individual switch or electrical outlet to disconnect each of unit separately from the power supply.

WARNING

- Follow ordinance of your governmental organization for technical standard related to electrical equipment, wiring regulations and guidance of each electric power company.
- Make sure to use specified wires for connections so that no external force is imparted to terminal connections. If connections are not fixed firmly, it may cause heating or fire.
- Make sure to use the appropriate type of overcurrent protection switch. Note that generated overcurrent may include some amount of direct current.

CAUTION

- Some installation site may require attachment of an earth leakage breaker. If no earth leakage breaker is installed, it may cause an electric shock.
- Do not use anything other than breaker and fuse with correct capacity. Using fuse and wire or copper wire with too large capacity may cause a malfunction of unit or fire.

Water charging

For water charging, please follow below procedures.

- Step 1.** Open all valves of whole water circuit. Supplied water should be charged not only inside the unit, but also in the under floor water circuit, sanitary water tank circuit, FCU water circuit, and any other water circuits controlled by the product.
- Step 2.** Connect supply water into drain valve and fill valve located at the side of the shut-off valve.
- Step 3.** Start to supply water. While supplying water, following should be kept.
- Pressure of supplying water should be 2.0 bar approximately.
 - For supplying water pressure, time to be taken from 0 bar to 2.0 bar should be more than 1 minute. Sudden water supply can yield water drain through safety valve.
 - About 2 turns open the cap of air vent to assure air purging (Refer to Figure 1). If air is exist inside the water circuit, then performance degrade, noise at the water pipe, mechanical damage at the surface of electric heater coil.
- Step 4.** Stop water supplying when the pressure gage located inside unit indicates 2.0 bar.
- Step 5.** Close drain valve and fill valve. Then wait for 20~30 seconds to observe water pressure being stabilized.
- Step 6.** If following conditions are satisfactory, then go to next(pipe insulation). Otherwise, go to step 3.
- Pressure gage indicates 2.0 bar. Note that sometimes pressure is decreased after step 5 due to water charging inside expansion vessel.
 - No air purging sound is heard or no water drop are popping out from air vent.

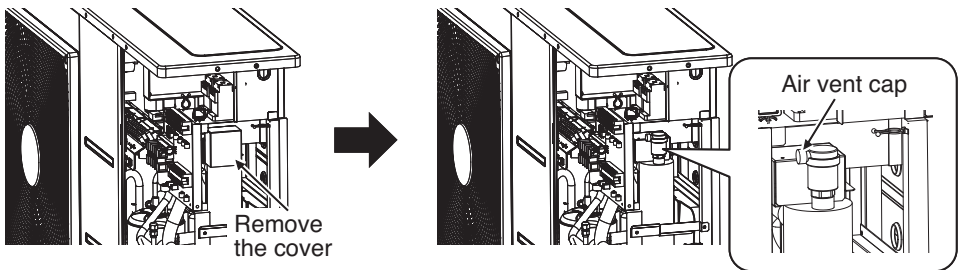

Procedures

1. Cover of electronic heater should be removed.
2. Open the air vent cap for air purging.
3. Reassembly the air vent cap & cover after air purge.

<Figure 1>

Installation of the final check

No.	Check point	Description
1	Connection of Water Inlet/Outlet	<ul style="list-style-type: none"> - Check if the shut-off valves should be assembled with Water inlet and outlet pipe of the unit - Check the location of the water inlet/outlet water pipe
2	Hydraulic pressure	<ul style="list-style-type: none"> - Check the pressure of supplying water by using pressure gage inside the unit - Pressure of Supplying water should be Under 3.0 bar approximately
3	Water pump speed	<ul style="list-style-type: none"> - To secure enough water flow rate, do not set water pump speed as 'Min'. - It can lead unexpected flow rate error CH14. (Refer to Chapter 4 'Water Piping and Water Circuit Connection')
4	Transmission line and power source wiring	<ul style="list-style-type: none"> - Check if Transmission line and power source wiring are separated from each other. - If it is not, electronic noise may occur from the power source.
5	The power cord specifications	<ul style="list-style-type: none"> - Check the power cord specifications (Refer to Chapter 4 'Connecting Cables')
6	3Way Valve	<ul style="list-style-type: none"> - Water should flow from Water outlet of the unit to sanitary tank Water inlet when sanitary tank heating is selected. - To verify the flow direction, Make sure that the water outlet temperature of the unit and water inlet temperature of sanitary Water tank are similar
7	2Way Valve	<ul style="list-style-type: none"> - Water should not flow into under floor loop in cooling mode. - To verify the flow direction, check temperature at the water inlet of the under floor loop. - If correctly wired, this temperatures should not be approached to 6°C in cooling mode.
8	Air Vent	<ul style="list-style-type: none"> - Air-vent must be located highest level of Water pipe system - It should be installed at the point which is easy to service. - It takes some times to remove air in the water system if air purge is not performed sufficiently it may occur CH14 error. (refer to Chapter 4 'Water Charging')

5. Accessories Installation

The Heat Pump can interface to various accessories to extend its functionality and to improve user convenience. In this chapter, accessories and how to connect to The Heat Pump is introduced.

See the 'System Set-Up' for a dip-switch settings and installer settings.

For accessories supported by your supplier, please refer to installation manual of each accessories.

⚠ WARNING

Followings should be kept before installation

- Main power must be turned off during installing 3rd party accessories.
- 3rd party accessories should be comply with supported specification.
- Proper tools should be chosen for installation.
- Never do installation with wet hands.

Installation of Remote Controller

1. Please fix tightly using provided screw after placing remote controller setup board on the place where you like to setup.

- Please set it up not to bend because poor setup could take place if setup board bends. Please set up remote controller board fit to the reclamation box if there is a reclamation box.

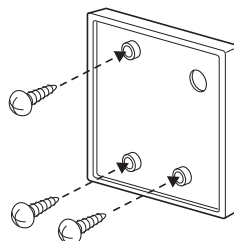

2. Can set up Wired remote controller cable into three directions.

- Setup direction: the surface of wall reclamation, upper, right
- If setting up remote controller cable into upper and right side, please set up after removing remote controller cable guide groove.

※ Remove guide groove with long nose.

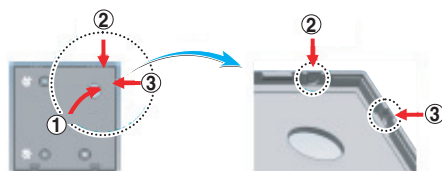

<Wire guide grooves>

- ① Reclamation to the surface of the wall
- ② Upper part guide groove
- ③ Right part guide groove

3. Please fix remote controller upper part into the setup board attached to the surface of the wall, as the picture below, and then, connect with setup board by pressing lower part.

- Please connect not to make a gap at the remote controller and setup board's upper and lower, right and left part.

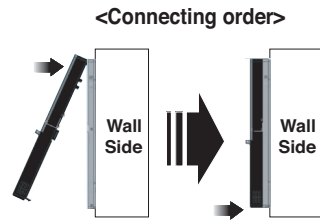

When separating remote controller from setup board, as the picture below, after inserting into the lower separating hole using screw driver and then, spinning clockwise, remote controller is separated.

- There are two separating holes. Please individually separate one at a time.
- Please be careful not to damage the inside components when separating.

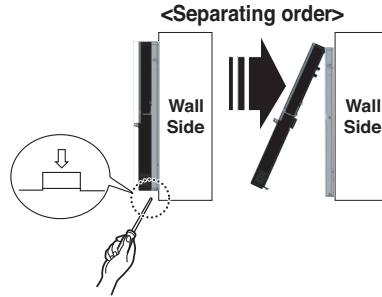

4. Please connect Main PCB (Heater) and remote controller using connection cable.

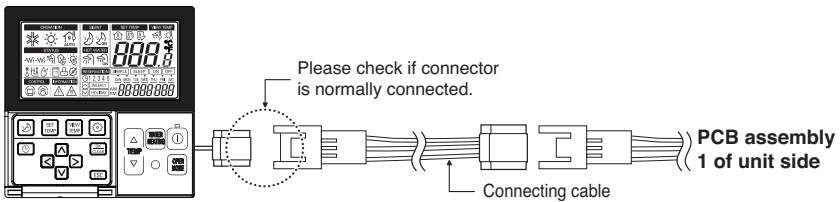

5. Please use extension cable if the distance between wired remote controller and unit is more than 10m.

⚠ CAUTION

When installing the wired remote controller, do not bury it in the wall.
(It can cause damage in the temperature sensor.)

Do not install the cable to be 50m or above. (It can cause communication error.)

- When installing the extension cable, check the connecting direction of the connector of the remote controller side and the product side for correct installation.
- If you install the extension cable in the opposite direction, the connector will not be connected.
- Specification of extension cable: 2547 1007 22# 2 core 3 shield 5 or above.

Thermostat

Thermostat is generally used to control the unit by air temperature. When thermostat is connected to the unit, the unit operation is controlled by the thermostat.

Installation condition

⚠ CAUTION

1. USE 220-240 V~ Thermostat
2. Some electro-mechanical type thermostat has internal delay time to protect compressor. In that case, mode change can take time more than user's expectation. Please read thermostat manual carefully if the unit does not response quickly.
3. Setting temperature range by thermostat can be different with that of the unit. The heating or cooling set temperature should be chosen within the setting temperature range of the unit.
4. It is highly recommended that the thermostat should be installed where space heating is mainly applied.

Following location should be avoid to secure proper operation :

- Height from floor is approximately 1.5 m.
- Thermostat can not be located where the area may be hidden when door is open.
- Thermostat can not be located where external thermal influence may be applied. (such as above heating radiator or open window)

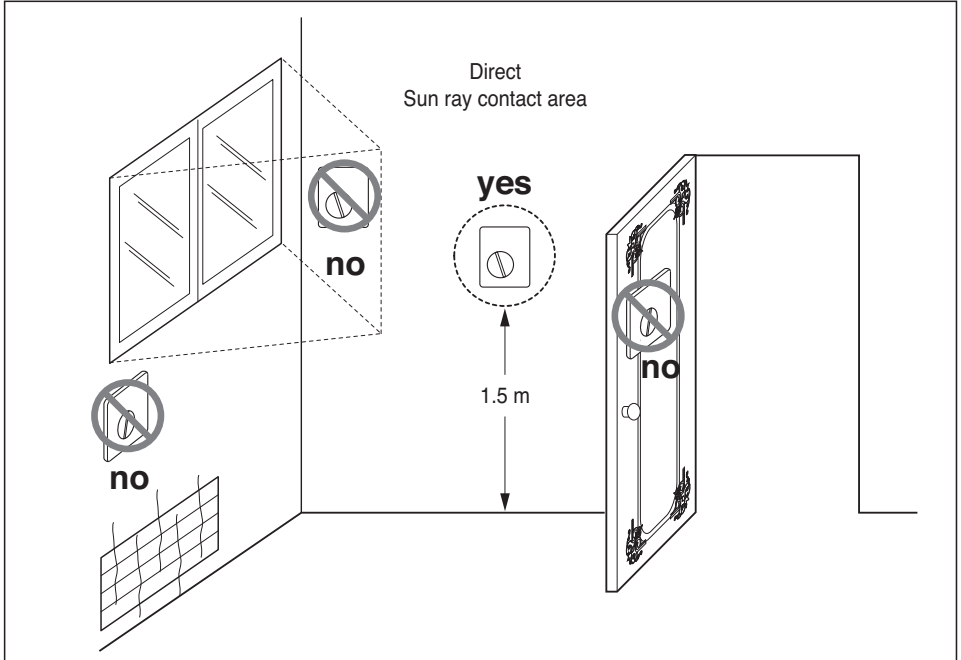

General information

The Heat Pump supports following thermostats.

Type	Power	Operating Mode	Supported
Mechanical (1)	230 V~	Heating Only (3)	Yes
		Heating / Cooling (4)	Yes
Electrical (2)	230 V~	Heating Only (3)	Yes
		Heating / Cooling (4)	Yes

- (1) There is no electric circuit inside the thermostat and electric power supply to the thermostat is not required.
- (2) Electric circuit such as display, LED, buzzer, etc is included in the thermostat and electric power supply is required.
- (3) Thermostat generates "Heating ON or Heating OFF" signal according to user's heating target temperature.
- (4) thermostat generates both "Heating ON or Heating OFF" and "Cooling ON or Cooling OFF" signal according to user's heating and cooling target temperature.

⚠ CAUTION

Choosing heating / cooling thermostat

- Heating / cooling thermostat must have "Mode Selection" feature to distinguish operation mode.
- Heating / cooling thermostat must be able to assign heating target temperature and cooling target temperature differently.
- If above conditions are not kept, the unit can not operation properly.
- Heating / cooling thermostat must send cooling or heating signal immediately when temperature condition is satisfied. No delay time while sending cooling or heating signal is permitted.

How to wire thermostat

Follow below procedures Step 1 ~ Step 5.

Step 1. Uncover front cover of the unit and open the control box.

Step 2. Identify the power specification of the thermostat. If it is 220-240 V~, go to Step 3.

Step 3. If it is Heating only thermostat, go to step 4. Otherwise, if it is Heating / cooling thermostat, go to step 5.

Step 4. Find terminal block and connect wire as below. After connecting, go to step 5.

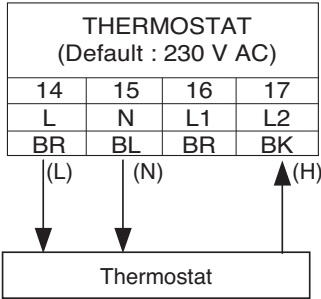

⚠ WARNING

Mechanical type thermostat

Do not connect wire (N) as mechanical type thermostat does not require electric power supply.

⚠ CAUTION

Do not connect external electric loads.

Wire (L) and (N) should be used only for operation electric type thermostat.

Never connect external electric loads such as valves, fan coil units, etc. If connected, Main PCB (Heater) can be seriously damaged.

(L) : Live signal from PCB to thermostat

(N) : Neutral signal from PCB to thermostat

(H) : Heating signal from thermostat to PCB

Step 5. Find terminal block and connect wire as below.

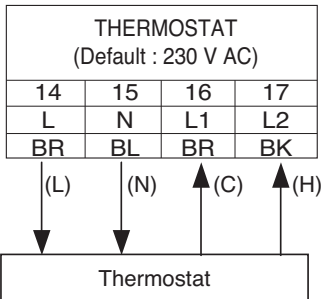

⚠ WARNING

Mechanical type thermostat

Do not connect wire (N) as mechanical type thermostat does not require electric power supply.

⚠ CAUTION

Do not connect external electric loads.

Wire (L) and (N) should be used only for operation Electric type thermostat.

Never connect external electric loads such as valves, fan coil units, etc. If connected, Main PCB (Heater) can be seriously damaged.

(L) : Live signal from PCB to thermostat

(N) : Neutral signal from PCB to thermostat

(C) : Cooling signal from thermostat to PCB

(H) : Heating signal from thermostat to PCB

Final check

- DIP switch setting :
Set DIP switch No. 8 to 'ON'. Otherwise, the unit can not recognize the thermostat.
- Remote Controller :
 - 'Thermostat' icon is displayed on the remote controller.
 - Button input is prohibited.

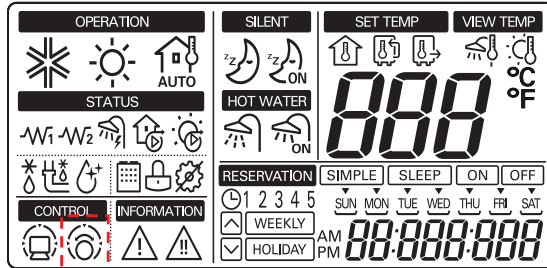





Thermostat Icon

NOTICE



Thermostat Operation with Remote Controller

Following features are permitted when thermostat is installed :

-  SET TEMP button
-  VIEW TEMP button
-  Temperature adjusting button(*)
-  Sanitary water heating Enable / Disable

(*) : Adjusted temperature is only used to control electric heater on / off condition.
The unit does not turn on / off according to the setting temperature at the remote controller.
It turns on / off according to the thermostat signal.

Following features are NOT permitted when thermostat is installed :

-  Operating mode (cooling / heating / weather-dependent) selection
-  Time scheduling
-  Operation On / Off

Sanitary Water Tank and Sanitary Water Tank Kit

To establish sanitary water circuit, 3way valve and sanitary water tank kit is required. If solar thermal system is pre-installed at the installation field, solar thermal kit is required to interface solar thermal system - to - sanitary water tank - to - The Heat Pump.

Installation condition

Installing sanitary water tank requires following considerations :

- Sanitary water tank should be located at the flat place.
- Water quality should be complied with EN 98/83 EC directives.
- As this water tank is sanitary water tank (indirect heat exchange), do not use anti water-freezing treatment like ethylene glycol.
- It is highly recommend to wash out inside of the sanitary water tank after installation. It ensures generating clean hot water.
- Near the sanitary water tank there should be water supply and water drain to easy access and maintenance.
- Set the maximum value of the temperature control device of sanitary tank.

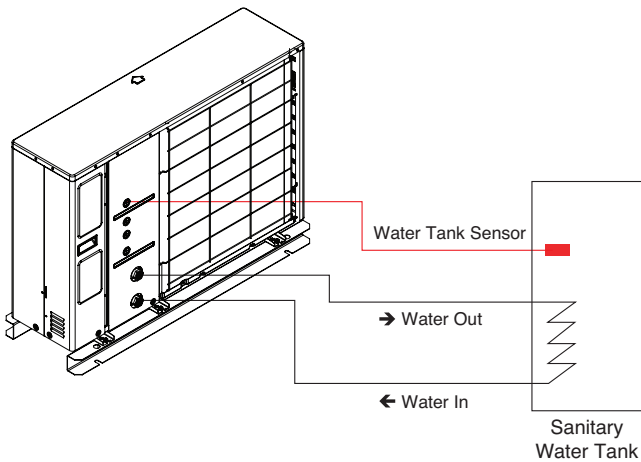

⚠ WARNING**Installing recirculation pump**

When is used with sanitary water tank, it is **STRONGLY** recommended to install recirculation pump to prevent flooding out cold water at the end of hot water supply and to stabilize the water temperature inside the sanitary water tank.

- The recirculation pump should be operated when sanitary water demand is not required.

Therefore, external time scheduler to determine when the recirculation pump should turn on and turn off is required.

- The operating duration time of the recirculation pump is calculated as follow :

$$\text{Duration time [minute]} = k * V * R$$

k : 1.2 ~ 1.5 is recommended. (If distance between pump and tank is far, then choose high number.)

V : Volume of sanitary water tank [liter]

R : Water flow rate of pump [liter per minute], which is determined by pump performance curve.

- The pump operating start time should be prior to the sanitary water demand.

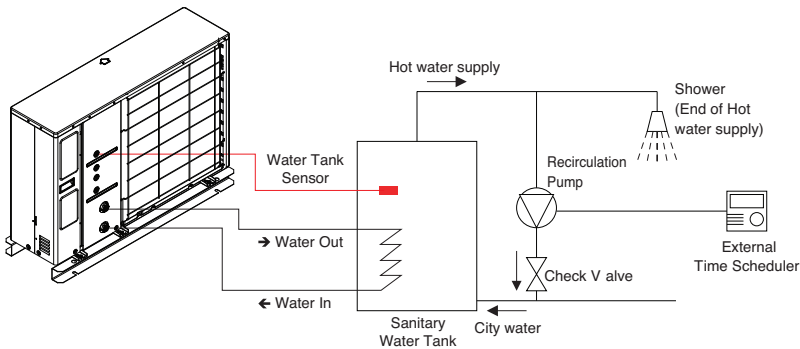
**How to install sanitary water tank**

For more detail information about installing sanitary water tank, please refer installation manual provided with sanitary water tank.

How to wire sanitary water tank heater

Step 1. Uncover heater cover of the sanitary water tank. Heater is located inside of the tank.

Step 2. Find terminal block in the water tank kit and connect wires as below. Wires are field-supplied item.

(L) : Live signal from Water tank kit to heater

(N) : Neutral signal from Water tank kit to heater

⚠ WARNING**Wire specification**

• Cross-sectional area of the wire should be 5 mm².

Adjusting thermostat temperature

• To guarantee proper operation, it is recommended to set temperature of thermostat to maximum temperature (symbol at the picture).

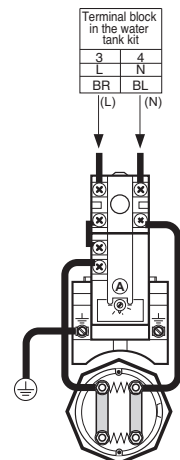

How to install sanitary water tank kit

Follow below procedures Step 1 ~ Step 5.

Step 1. Uncover the water tank kit and locate it on the wall.

Step 2. Connect the water tank kit to the main power like the below figure 2.

Step 3. Connect the water tank kit to the Main PCB assembly(Heater) like the below figure 2.

Step 4. Connect power cord of sanitary tank heater. It is located inside of the tank. Refer to the next page for more information.

Step 5. Find sanitary water tank sensor. Plug it to 'CN_TH4' (Red Connector) of the Main PCB assembly(Heater). The sensor should be mounted correctly to the sensor hole of sanitary water tank. Like below figure. 1

Step 6. Connect the Main PCB to terminal block with wire(Part 4) like figure 3.

※ This wire is only for AHBWXXXA0 model.

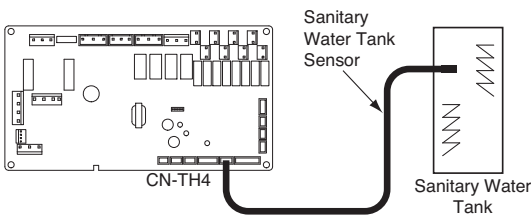

Fig. 1

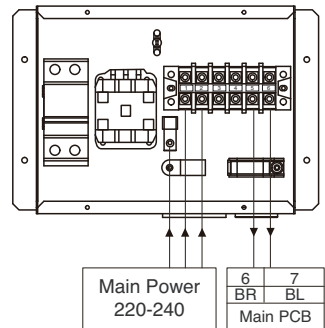

Fig. 2

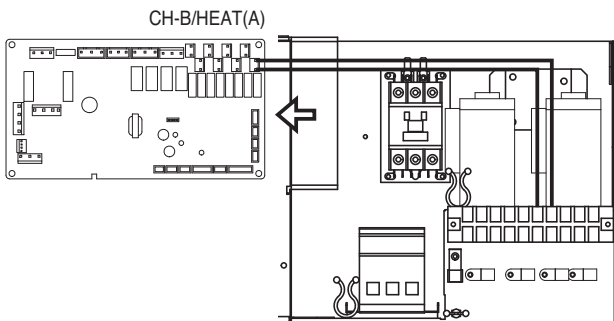

Fig. 3

⚠ CAUTION

Sensor mounting

Insert sensor into sensor socket and bolt it tightly.

Dry Contact

LG Dry Contact is a solution for automatic control of air conditioning system at the owner's behest. In simple words, it's a switch which can be used to turn the unit On/Off after getting the signal from external sources like key-in lock, door or window switch etc specially used in Hotel rooms.

How to Install Dry Contact

Connect CN_DRY with Control Unit.

- To apply power source through Dry Contact PCB.

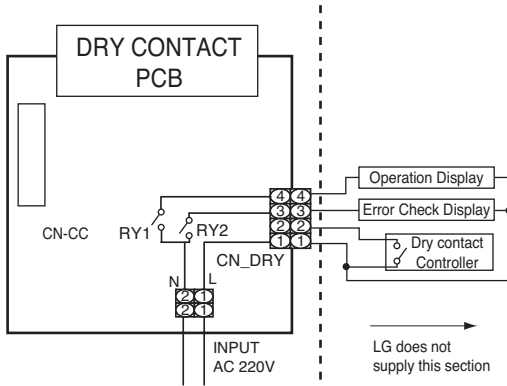

- To apply power source directly to external source.

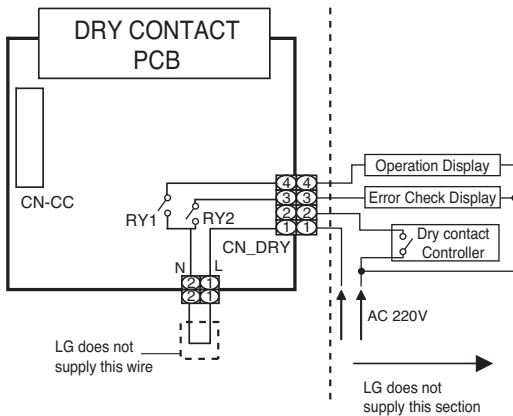

Remote Temperature Sensor

Remote temperature sensor can be installed any place a user wants to detect the temperature.

How to Install Remote Temperature Sensor

Step 1. After deciding where the remote temperature sensor is installed, decide the location and height of the fixing screws. (Interval between the screws : 60mm)

Step 2. Insert the connector of the connection wire into the space for the connector in place of the room temperature sensor.(CN_ROOM)

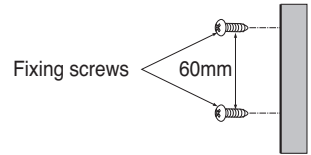

Step 3. Separately, set the option code of the attached controller on the unit.
In detail, refer to "installer setting mode".

Step 4. The Connection wire does not matter if you change the color of the wire because of non-polar.

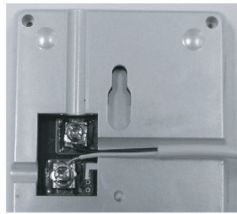

Step 5. Integrate the remote temperature sensor with the screws as the order of arrows.

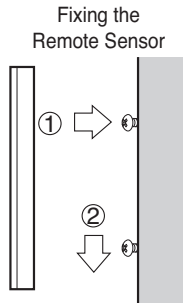

CAUTION

1. Choose the place where the average temperature can be measured for the unit operates.
2. Avoid direct sunlight.
3. Choose the place where the cooling/heating devices do not affect the remote sensor.
4. Choose the place where the outlet of the cooling fan do not affect the remote sensor.
5. Choose the place where the remote sensor isn't affected when door is open.

3Way Valve

3way valve is required to operate sanitary water tank. Role of 3way valve is flow switching between under floor heating loop and water tank heating loop.

General information

THERMAV supports following 3way valve.

Type	Power	Operating Mode	Supported
SPDT 3-wire (1)	220-240 V~	Selecting "Flow A" between "Flow A" and "Flow B" (2)	Yes
		Selecting "Flow B" between "Flow A" and "Flow B" (3)	Yes

(1) : SPDT = Single Pole Double Throw. Three wires consist of Live1 (for selecting Flow A), Live 2 (for selecting Flow B), and Neutral (for common).

(2) : Flow A means 'water flow from the unit to under floor water circuit.'

(3) : Flow B means 'water flow from the unit to sanitary water tank.'

How to wire 3way valve

Follow below procedures Step 1 ~ Step 2.

Step 1. Uncover front cover of the unit.

Step 2. Find terminal block and connect wire as below.

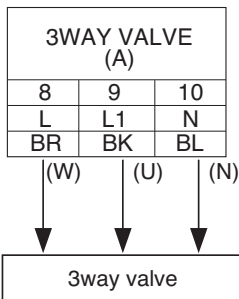

- 3way valve should select water tank loop when electric power is supplied to wire (W) and wire (N).
- 3way valve should select under floor loop when electric power is supplied to wire (U) and wire (N).

(W) : Live signal (Water tank heating) from PCB to 3way valve

(U) : Live signal (Under floor heating) from PCB to 3way valve

(N) : Neutral signal from PCB to 3way valve

⚠ WARNING

Mice can not be appeared to prevent entering the unit or attacking wires.

Final check

- Flow direction :
 - Water should flow from water outlet of the unit to sanitary tank water inlet when sanitary tank heating is selected.
 - To verify the flow direction, check temperature at the water outlet of the unit and water inlet of sanitary water tank.
 - If correctly wired, these temperatures should be almost equivalent if thermal insulation of water pipe is well performed.

- Noise or water pipe vibration while 3way valve operation
 - Due to surging effect or cavitation effect, noise or water pipe vibration can be occurred while 3way valve is operating.
 - In that case, check followings :
 - Is water circuit (both under floor water loop and sanitary water tank loop) fully charged? If not, additional water charging is required.
 - Fast valve operation yields noise and vibration. Appropriated valve operating time is 60~90 seconds.

Air-Vent

- For correct operation of the unit, all air in the system must be exhausted by manual air-vent. (located on the top of heater case)
 - It is easy to exhaust air during charging water into the system.
- Also, air can be exhausted by additional automatic air-vent. (Additional air-vent must be located highest level of water pipe system.)

2Way Valve

2way valve is required to control water flow while cooling operation. Role of 2way valve is to cut off water flow into under floor loop in cooling mode when fan coil unit is equipped for cooling operation.

General Information

THERMAV supports following 2way valve.

Type	Power	Operating Mode	Supported
NO 2-wire (1)	230V AC	Closing water flow	Yes
		Opening water flow	Yes
NC 2-wire (2)	230V AC	Closing water flow	Yes
		Opening water flow	Yes

(1) : Normal Open type. When electric power is NOT supplied, the valve is open. (When electric power is supplied, the valve is closed.)

(2) : Normal Closed type. When electric power is NOT supplied, the valve is closed. (When electric power is supplied, the valve is open.)

How to Wire 2Way Valve

Follow below procedures Step 1 ~ Step 2.

Step 1. Uncover front cover of the indoor unit and open the control box.

Step 2. Find terminal block and connect wire as below.

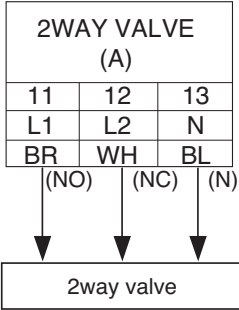

⚠ CAUTION

Dew Condensation

- Wrong wiring can yield dew condensation on the floor. If radiator is connected at the under floor water loop, dew condensation can be occurred on the surface of the radiator.

⚠ WARNING

Wiring

- Normal Open type should be connected to wire (NO) and wire (N) for valve closing in cooling mode.
- Normal Closed type should be connected to wire (NC) and wire (N) for valve closing in cooling mode.

(NO) : Live signal (for Normal Open type) from PCB to 2way valve

(NC) : Live signal (for Normal Closed type) from PCB to 2way valve

(N) : Neutral signal from PCB to 2way valve

Final Check

- Flow direction :
 - Water should not flow into under floor loop in cooling mode.
 - To verify the flow direction, check temperature at the water inlet of the under floor loop.
 - If correctly wired, this temperatures should not be approached to 6°C in cooling mode.

6. System Set-Up

The Heatpump is designed to satisfy various installation environment, it is important to set up system correctly. If not configured correctly, improper operation or degrade of performance can be expected.

DIP Switch Setting

⚠ CAUTION

Turn off electric power supply before setting DIP switch.

- Whenever adjusting DIP switch, turn off electric power supply to avoid electric shock.

General information (Main PCB assembly(Heater))

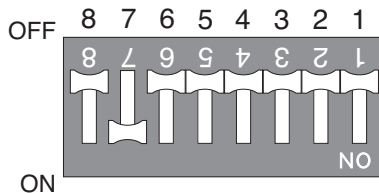
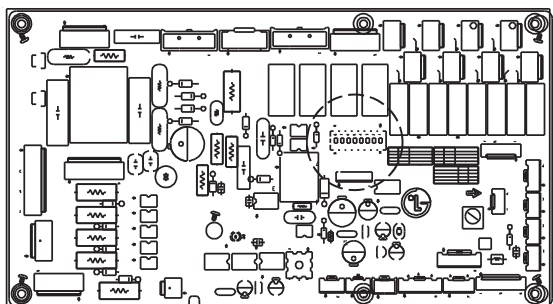

DIP switch information

- If you set Dip switch when power is on, the changed setting will not be applied immediately. The changed setting will be enabled only when Power is reset or by pressing Reset button.

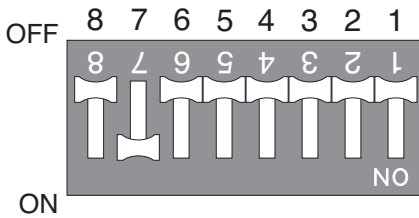

Description	Setting	1	2	3	4	5	6	7	8
Role when central controller is equipped.	As Master	X							
	As slave	●							
Accessory installation information	Unit only		X	X					
	Unit + Sanitary water tank is installed.		X	●					
	Unit + Sanitary water tank +Solar thermal system is installed.		●	X					
Emergency operation Level.	High temperature cycle				X				
	Low temperature cycle				●				
External water pump installation information.	External water pump is NOT installed.					X			
	External water pump is installed.					●			
Selecting electric heater capacity.	Step 2** capacity is used.						X	X	
	Step 1* capacity is used.						X	●	
	Electric heater is not used.						●	X	
Thermostat installation information.	Thermostat is NOT installed.								X
	Thermostat is installed.								●
Default		X	X	X	X	X	X	●	X

* Step 1. operate heater partially.

** Step 2. operate heater fully.

⚠ CAUTION

1. "X" mark means dip switch must be off. Otherwise the function may not operate correctly.
2. If each dip switch doesn't set correctly, unit will operate abnormally.
3. In case of proceeding test run, start after checking if all unit is off.

! NOTICE

Emergency operation

- **Definition of terms**

- **Trouble** : a problem which can stop system operation, and can be resumed temporally under limited operation without certificated professional's assist.
- **Error** : problem which can stop system operation, and can be resumed ONLY after certificated professional's check.
- **Emergency mode** : temporary heating operation while system met trouble.

- **Objective of introducing 'trouble'**

- Not like airconditioning unit, Air-to-Water heat pump is generally operating in whole winter season without any system stopping.
- If system found some problem, which is not critical to system operating for yielding heating energy, the system can temporarily continue in emergency mode operation with end user's decision.

- **Classified trouble**

- Trouble is classified two levels according to the seriousness of the problem : Slight Trouble and heavy trouble
- **Slight trouble** : Sensor trouble.
- **Heavy trouble** : Compressor cycle trouble.
- **Option trouble** : a problem is found for option operation such as water tank heating. In this trouble, the troubled option is assumed as if it is not installed at the system.





- **Emergency operation level**

- When system met trouble, it stops operation and wait for user's decision : Calling service center or starting emergency operation.
- To start emergency operation, user simply push ON / OFF button once more.
- Two different levels are prepared for emergency operation : High temperature cycle and low temperature cycle.
- In emergency operation mode, user can not adjust target temperature.

* It can not be operated, if the electric heater accessory is not installed.

	DIP Switch (#4)	Target Leaving Water Temperature	Target Room Air Temperature	Target Sanitary Water Temperature
High temperature cycle	OFF	50 °C	24 °C	70 °C
Low temperature cycle	ON	30 °C	19 °C	50 °C

• **Following features are permitted in emergency operation :**



-  Operation On/Off
-  VIEW TEMP button(*)
-  Temperature adjust button (*)
-  Sanitary water heating Enable / Disable

(*) : Temperature measured by failed sensor is displayed as '- -'.

(*) : Adjusted temperature is only used to control electric heater on / off condition.

The unit does not turn on / off according to the setting temperature at the remote controller. It turns on / off according to the thermostat signal.

• **Following features are NOT permitted in emergency operation :**

-  Operating mode (cooling / heating / weather-dependent) selection
-  Time scheduling
-  SET TEMP button

• **Duplicated trouble : Option trouble with slight or heavy trouble**

If option trouble is occurred with slight (or heavy) trouble at the same time, the system puts higher priority to slight (or heavy) trouble and operates as if slight (or heavy) trouble is occurred. Therefore, sometimes sanitary water heating can be impossible in emergency operation mode. When sanitary water is not warming up while emergency operation, please check whether the sanitary water sensor and related wiring are connected well or not.

• **Emergency operation is not automatically restarted after main electricity power is reset.**

In normal condition, the unit operating information is restored and automatically restarted after main electricity power is reset.

But in emergency operation, automatic re-start is prohibited to protect the unit.

Therefore, user must restart the unit after power reset when emergency operation has been running.

Installer Setting

How to enter installer setting mode

⚠ CAUTION

Installer setting mode is to set the detail function of the remote controller.

If the installer setting mode is not set correctly, it could cause problems to the unit, user injury or property damage. This must be set by a certificated installer, and any installation or change that is carried out by a non-certificated person should be responsible for the results. In this case, free service cannot be provided.

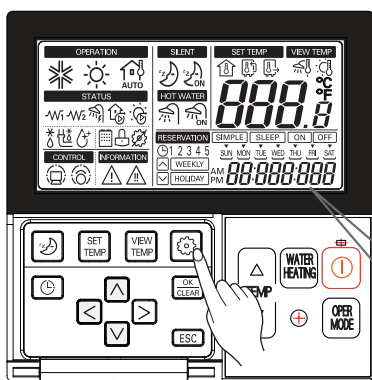

1 Press Function Setting button for 3 seconds to enter the installer setting mode.

Function Code Value

(When you enter the installer setting mode initially, function code is displayed on the bottom of the LCD screen.)

Repeat pressing button, and the function code will be changed from 01 to 2B.
Please refer the code table on the next page.

Summary

Example of function code display

02:00 1: 155

 ↓ ↓ ↓

 Function Code Value #1 Value #2

Code	Item	Detail	Remark	
01	Function	Additional refrigerant charging		
	Description	Instant cooling operation for charging additional refrigerant		
	Value #1	Note		-
		Default		01
		Range		-
	Value #2	Note		-
		Default		-
Range		-		
02	Function	Disable 3 minute delay		
	Description	Factory use only		
	Value #1	Note		-
		Default		01
		Range		-
	Value #2	Note		-
		Default		-
Range		-		
03	Function	Remote air sensor connection		
	Description	Connection information about remote air sensor		
	Value #1	Note		01:Remote air sensor is not connected and not used. 02:Remote air sensor is connected and used.
		Default		1
		Range		01 ~ 02
	Value #2	Note		-
		Default		-
Range		-		
04	Function	Celsius / Fahrenheit switching		
	Description	Display temperature in Celsius or Fahrenheit		
	Value #1	Note		01:Celsius 02:Fahrenheit
		Default		1
		Range		01 ~ 02
	Value #2	Note		-
		Default		-
Range		-		

System Set-Up

Code	Item	Detail	Remark	
05	Function	Setting temperature selection		
	Description	Selection for setting temperature as air temperature or leaving water temperature.		
	Value #1	Note		01:Air temperature 02:Leaving water temperature Air temperature as setting temperature is ONLY available when remote air sensor. Connection is enabled and Function code 03 is set as 02.
		Default		2
		Range		01 ~ 02
	Value #2	Note		-
		Default		-
		Range		-
06	Function	Auto dry contact		
	Description	Setting dry contact auto start option. If thermostat is used, value should be changed from "2" to "1".		
	Value #1	Note		01 : Auto start off 02: Auto start on
		Default		2
		Range		01 ~ 02
	Value #2	Note		-
		Default		-
		Range		-
07	Function	Address setting		
	Description	Assigning address when central controller is installed If thermostat is used, value should be changed from "2" to "1".		
	Value #1	Note		-
		Default		00
		Range		00 ~ FF
	Value #2	Note		-
		Default		-
		Range		-
11	Function	Setting air temperature in cooling mode	'Setting Air Temperature' is used when user wants to set target temperature by room air temperature.	
	Description	Adjusting range of 'Setting Air Temperature' in cooling mode		
	Value #1	Note		Upper limit of setting range
		Default		30 °C
		Range		24 ~ 30 °C
	Value #2	Note		Lower limit of setting range
		Default		18 °C
Range		18 ~ 22 °C		
12	Function	Setting leaving water temperature in cooling mode	'Setting Leaving Water Temperature' is used when user wants to set target temperature by leaving(from the unit) water temperature.	
	Description	Adjusting range of 'Setting Leaving Water Temperature' in cooling mode		
	Value #1	Note		Upper limit of setting range
		Default		24 °C
		Range		20 ~ 25 °C
	Value #2	Note		Lower limit of setting range(FCU is equipped)
		Default		06 °C
Range		06 ~ 18 °C		

Code	Item	Detail		Remark	
13	Function	Setting air temperature in heating mode		'Setting air temperature' is used when user wants to set target temperature by room air temperature.	
	Description	Adjusting range of 'Setting Air Temperature' in heating mode			
	Value #1	Note	Upper Limit of setting range		
		Default	30 °C		
		Range	24 ~ 30 °C		
	Value #2	Note	Lower Limit of setting range		
Default		16 °C			
Range		16 ~ 22 °C			
14	Function	Setting leaving water temperature in heating mode		'Setting leaving Water temperature' is used when user wants to set target temperature by leaving(from the unit) water temperature. * : Electric heater is not used	
	Description	Adjustin range of 'Setting Leaving Water Temperature' in heating mode			
	Value #1	Note	Upper Limit of setting range		
		Default	57 °C		
		Range	35 ~ 57 °C		
	Value #2	Note	Lower Limit of setting range		
Default		15 °C (*20 °C)			
Range		15 ~ 34 °C (*20 ~ 34 °C)			
15	Function	Setting sanitary tank leaving water temperature for Sanitary water heating		'Setting Sanitary Tank Leaving Water Temperature' is used when user wants to set water temperature of Sanitary Tank.	
	Description	Adjusting range of 'Setting Sanitary Tank Leaving Water Temperature' in sanitary water heating mode			
	Value #1	Note	Upper Limit of setting range		
		Default	50 °C		
		Range	50 ~ 80 °C		
	Value #2	Note	Lower Limit of setting range		
Default		40 °C			
Range		30 ~ 40 °C			
18	Function	Screed drying mode			
	Description	After installing water pipes for under floor heating, user can select screed drying mode for curing the cement			
	Value #1	Note	00:Screed drying mode is not used. 01:Screed drying mode is used.		
		Default	00		
		Range	00 ~ 01		
	Value #2	Note	-		
Default		-			
Range		-			
21	Function	Setting electric heater on / off temperature		DIP Switch setting is described in Chapter 6 of Installation Manual.	
	DIP switch setting	No.6 = Off No.7 = On	No.6 = Off No.7 = Off		
	Description	Setting for using Step 1 capacity of electric heater	Setting for using Step 2 capacity of electric heater		
	Value #1	Note	Outdoor air temperature where Step 1 capacity of electric heater starts operation.		Base outdoor air temperature
		Default	0 °C		
		Range	-15 ~ 18 °C		
	Value #2	Note	Not used		Not used
		Default	-		-
Range		-	-		

Code	Item	Detail	Remark	
22	Function	Setting cut-off temperature in cooling mode (FCU setting included)		
	Description	Determine leaving water temperature when the unit is turned off. This function is used for preventing condensation on the floor in cooling mode.		
	Value #1	Note		Cut-off temperature. Value #1 is valid when Value #2 is '01 (that means, FCU is not installed)'.
		Default		16 °C
		Range		16 ~ 25 °C
	Value #2	Note		Determines if FCU is installed or not. '01' means 'FCU is not installed', and '00' means 'FCU is installed.'
		Default		00
		Range		00(Equipped) ~ 01(not Equipped)
23	Function	Setting outdoor temperature range for weather-dependent operation		
	Description	Setting outdoor Max/Min temperature for weather-dependent operation		
	Value #1	Note		Upper Limit of setting range
		Default		-10 °C
		Range		-20 ~ 05 °C
	Value #2	Note		Lower Limit of setting range
		Default		15 °C
		Range		10 ~ 20 °C
24	Function	Setting indoor air temperature range for weather-dependent operation		
	Description	Setting indoor Max/Min temperature for weather-dependent operation		
	Value #1	Note		Upper limit of setting range
		Default		21 °C
		Range		20 ~ 30 °C
	Value #2	Note		Lower limit of setting range
		Default		16 °C
		Range		16 ~ 19 °C
25	Function	Setting leaving water temperature range for weather-dependent operation		
	Description	Setting leaving water max / min temperature for weather-dependent operation		
	Value #1	Note		Upper limit of setting range
		Default		57 °C
		Range		35 ~ 57 °C
	Value #2	Note		Lower limit of setting range
		Default		15 °C (*20 °C)
		Range		15 ~ 34 °C (*20 ~ 34 °C)

Code	Item	Detail	Remark	
26	Function	Setting disinfection operation	Sanitary water heating should be enable. • If sanitary water heating is disable, the disinfection mode will not be operated although Value #1 of Code 26 is set as '01'. • To use disinfection mode, sanitary water heating should be enable.	
	Description	Setting start/maintain time for disinfection		
	Value #1	Note		Enable / Disable of disinfection operation (00:Disable , 01:Enable)
		Default		00
		Range		00 ~ 01
	Value #2	Note		Starting date (Sunday:1,Monday:2, ..., Saturday:7)
		Default		06
		Range		01 ~ 07
	Value #3	Note		Starting time in 24 hours(00 ~ 23)
		Default		23
Range		00 ~ 23		
27	Function	Setting Disinfection Operation	• To use disinfection mode, sanitary water heating should be enable.	
	Description	Setting disinfection temperature		
	Value #1	Note		Maximum heating temperature
		Default		70 °C
		Range		40 ~ 80 °C
	Value #2	Note		Maximum heating duration in minute
		Default		10 min
		Range		05 ~ 60 min
28	Function	Setting control parameter for sanitary water heating operation	Only available when Sanitary Water Tank is installed.	
	Description	See below notes for each values		
	Value #1	Note		Temperature gap from Value #2 of Function Code 28
		Default		05 °C
		Range		01 ~ 20 °C
	Value #2	Note		Maximum temperature generated by AWHP compressor cycle
		Default		48 °C
		Range		40 ~ 50 °C
29	Function	Setting control parameter for sanitary water heating operation	Only available when Sanitary Water Tank is installed.	
	Description	See below notes for each values		
	Value #1	Note		Temperature gap from target sanitary water temperature. (This value is required to frequent ON and OFF of water tank heater.)
		Default		03 °C
		Range		02 ~ 04 °C
	Value #2	Note		Determining heating demand priority between sanitary water tank heating and under floor heating
		Default		00
		Range		00 ~ 01

Code	Item	Detail	Remark	
2A	Function	Miscellaneous setting		
	Description	Determine electric heater and water heater on and off		
	Value #1	Note	00: Operate both electric heater and Domestic hot water tank heater 01: Operate only Domestic hot water tank heater	
		Default	00	
		Range	00 ~ 01	
	Value #2	Note	Not used	
		Default	-	
Range		-		
2B	Function	Domestic hot water heating timers		
	Description	Determine following time duration : operation time of Domestic hot water tank heating, stop time of Domestic hot water tank heating, and delay time of sanitary tank heater operating.		
	Value #1	Note	This time duration defines how long time Domestic hot water tank heating can be continued.	
		Default	30 min	
		Range	5 ~ 95 min (step: 5 min)	
	Value #2	Note	This time duration defines how long time sanitary tank heating can be stopped. It is also regarded as time gap between Domestic hot water tank heating cycle.	
		Default	180 min	
		Range	0 ~ 600 min (step: 30 min)	
	Value #3	Note	This time duration defines how long time Domestic hot water tank heater will not be turned on in Domestic hot water heating operation.	
		Default	20 min	
		Range	20 ~ 95 min (step: 5 min)	
	2E	Function	Changing thermal on / off room air temp	
Description		Select Thermal on / off Temperature gap.		
Value #1		Note	Thermal on Thermal off	
			0 -0.5 °C 1.5 °C	
			1 4 °C 6 °C	
			2 2 °C 4 °C	
3 -1 °C 1 °C				
Default	0			
Range	0 ~ 3			
2F	Function	Changing thermal on / off leaving water Temp		
	Description	Select Thermal on / off Temperature gap.		
	Value #1	Note	Thermal on Thermal off	
			0 -2 °C 2 °C	
			1 -6 °C 4 °C	
			2 -2 °C 4 °C	
3 -1 °C 1 °C				
Default	0			
Range	0 ~ 3			

※ Some contents may not be displayed depending on DIP switch setting in the Main PCB assembly(Heater).

Common setting

- **Function Code 01** : Additional refrigerant charging

Additional refrigerant charging should be performed when additional refrigerant charging is required. To charge the refrigerant, the unit must run in cooling mode. Additional refrigerant charging instantly makes the unit working in cooling mode for 18 minutes.

- Note** :
- If you press any kind of button during this mode, Additional refrigerant charging mode will be finished.
 - After running 18 minutes under additional refrigerant charging mode, system will automatically turn OFF.

- **Function Code 02** : Disable 3 minute delay

Factory use only.

- **Function Code 03** : Remote air sensor connection

If user connects remote air sensor to control the unit by room air temperature, the connection information should be notified to the unit.

- Note** : If remote air sensor is connected but this function code is not set correctly, the unit can not be controlled by room air temperature.

- **Function Code 04** : Celsius / Fahrenheit switching

Temperature is displayed in Celsius or Fahrenheit.

- **Function Code 05** : Setting temperature selection

The unit can be operated according to air temperature or leaving water temperature. The selection for setting temperature as air temperature or leaving water temperature is determined.

- Note** : Air temperature as setting temperature is ONLY available when remote air sensor connection is enabled and Function Code 03 is set as 02.

- **Function Code 06** : Auto dry contact

This function allows the dry contact operate under auto run mode or manual mode with remote controller.

If thermostat is used, value should be changed from "2" to "1".

- **Function Code 07** : Address setting

When central controller is installed, address assigning is set by this function.

Temperature range setting

- **Function Code 11** : Setting air temperature in cooling mode
Determine cooling setting temperature range when air temperature is selected as setting temperature.

! NOTICE

Only available when remote air temperature sensor is connected.

- Accessory PQRSTA0 should be installed.
 - Also, Function Code 03 should be set properly.
- **Function Code 12** : Setting leaving water temperature in cooling mode
Determine cooling setting temperature range when leaving water temperature is selected as setting temperature.

! NOTICE

Water condensation on the floor

- While cooling operation, it is very important to keep leaving water temperature higher than 16 °C. Otherwise, dew condensation can be occurred on the floor.
- If floor is in humid environment, do not set leaving water temperature below 18 °C.

! NOTICE

Water condensation on the radiator

- While cooling operation, cold water may not flow to the radiator. If cold water enters to the radiator, dew generation on the surface of the radiator can be occurred.
- **Function Code 13** : Setting air temperature in heating mode
Determine heating setting temperature range when air temperature is selected as setting temperature.

! CAUTION

Only available when remote air temperature sensor is connected.

- Accessory PQRSTA0 should be installed.
 - Also, Function Code 03 should be set properly.
- **Function Code 14** : Setting leaving water temperature in heating mode
Determine heating setting temperature range when leaving water temperature is selected as setting temperature.
- **Function Code 15** : Setting sanitary tank leaving water temperature
Determine heating setting temperature range of water tank leaving water.

! NOTICE

Only available when sanitary water tank feature is installed.

- Sanitary water tank and sanitary water tank kit should be installed.
 - DIP switch No. 2 and 3 should be set properly.
- **Function Code 18** : Screed drying mode.
After installing water pipes for under floor heating, user can select screed drying mode for curing the cement.

- 1** Keep pressing programming button for 3 seconds to enter setting screen drying mode.



- 2** Press programming button to select function code 18.

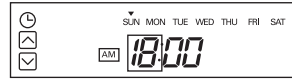

- 3** Press left, right button to move to screed drying setting part.

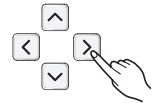

- 4** Press up, down button to adjust "01" or "00"
(00: Not Used 01: Used)

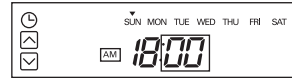

- 5** If you finish the setting, press OK / CLEAR button.

- 6** Press exit button to exit or system will automatically release without any input 25 seconds.



- 7** During the screed drying mode, "dry" is displayed.
Left days for completing the screed drying mode are displayed.

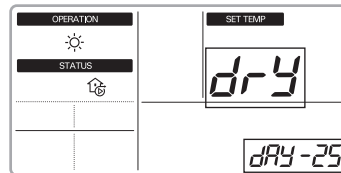

Left days

Temperature control parameter setting and etc

- **Function Code 21** : Setting electric heater On / Off temperature

Using Step 1 capacity of electric heater : when DIP switch No. 6 and 7 is set as 'OFF-ON' :

- Value #1 : outdoor air temperature where Step 1 capacity of electric heater starts operation.
- Value #2 : not used.
- Example : If Value #1 is set as '-1' and DIP switch No 6. and 7 is set as 'OFF-ON', then Step 1 capacity of electric heater will start operation when outdoor air temperature is below -1 °C and current leaving water temperature or room air temperature is much lower than target leaving water temperature or target room air temperature.

Using Step 2 capacity of electric heater : when DIP switch No. 6 and 7 is set as 'OFF-OFF' :

- Value #1 : base outdoor air temperature.
- Value #2 : not used
- Example : If Value #1 is set as '-1' and DIP switch No 6. and 7 is set as 'OFF-OFF', then step2 capacity of electric heater will start operation when outdoor air temperature is below -1 °C and current leaving water temperature or room air temperature is much lower than target leaving water temperature or target room air temperature.

- **Function Code 22** : Setting cut-off temperature in cooling mode (FCU setting included)

Determine leaving water temperature when the unit is turned off. This function is used for preventing condensation on the floor in cooling mode.

- Value #1 : cut-off temperature. Value #1 is valid when Value #2 is '01 (that means, FCU is installed)'.
- Value #2 : determines if FCU is installed or not. '01' means 'FCU is NOT installed', and '00' means 'FCU is installed.'
- Example : If Value #1 is set as '10' and Value #2 is '01' and actually FCU is NOT installed in the water loop, the unit stop operation in cooling mode when the leaving water temperature is below 10 °C.
- Example : If Value #1 is set as '10' and Value #2 is '00' and actually FCU is installed in the water loop, the Value #1 is not used and the unit do NOT stop operation in cooling mode when the leaving water temperature is below 10 °C.

! NOTICE

FCU Installation

- If FCU is used, related 2way valve should be installed and connected to the Main PCB assembly(Heater).
- If Value #2 is set as '00' but FCU or 2way valve is NOT installed, the unit can do abnormal operation.

• Function Code 23, 24, and 25 : Setting weather-dependent operation

Weather-dependent operation is that the unit automatically adjusts target temperature (leaving water or room air) according to the outdoor air temperature.

- Value #1 and Value #2 of Function Code 23 : range of outdoor air temperature
- Value #1 and Value #2 of Function Code 24 : range of auto-adjustable target room air temperature
- Value #1 and Value #2 of Function Code 25 : range of auto-adjustable target leaving water temperature

Note : Weather-dependent operation is applied for heating mode only.

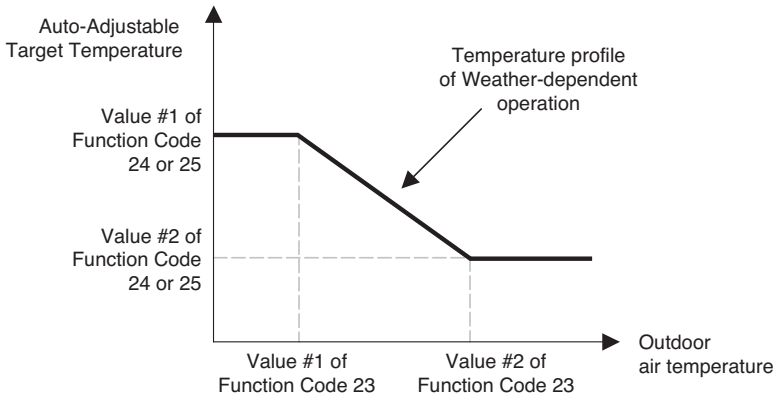

• **Function Code 26 and 27** : Setting disinfection operation

Disinfection operation is special sanitary tank operation mode to kill and to prevent growth of viruses inside the tank.

- Value #1 of Function Code 26 : Selecting enable or disable of disinfection operation. '00' for disable, and '01' for enable.
- Value #2 of Function Code 26 : Determining the date when the disinfection mode is running. '01' for Sunday, '02' for Monday, ... , and '07' for Saturday.
- Value #3 of Function Code 26 : Determining the time when the disinfection mode is running. '00' for 0:00am, '01' for 01:00am, ... , '22' for 10:00pm, and '23' for 11:00pm.
- Value #1 of Function Code 27 : Target temperature of disinfection mode.
- Value #2 of Function Code 27 : Duration of disinfection mode.

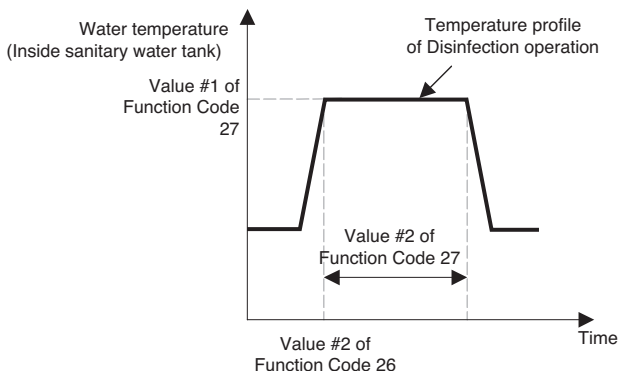

! NOTICE

Vales of Function Code 26

- If Value #1 of Function Code 26 is set as '00', that is 'disable disinfection mode', Value #2 and Value #3 is not used.
- When Value #1 is set as '01', that is 'enable disinfection mode,' Value #2 is displayed at the position of Value #1 and Value #3 is displayed at the position of Value #2. It is due to limited width of the remote controller display.

! NOTICE

Sanitary water heating should be enable.

- If sanitary water heating is disable, the disinfection mode will not be operated although Value #1 of Code 26 is set as '01'.
- To use disinfection mode, sanitary water heating should be enable.(by button input or scheduler programming)

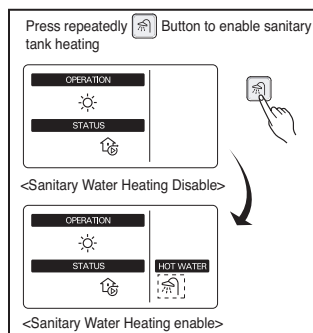

• **Function Code 28 and 29** : Setting control parameter for sanitary water heating operation

Descriptions for each parameters are as following.

- Value #1 of Function Code 28 : temperature gap from Value #2 of Function Code 28.
- Value #2 of Function Code 28 : maximum temperature generated by AWHP compressor cycle.
- Example : If Value #1 is set as '5' and Value #2 is set as '48', then Session A (see the graph) will be started when the water tank temperature is below 45 °C.... If temperature is above 48 °C..., then Session B will be started.
- Value #1 of Function Code 29 : temperature gap from target sanitary water temperature. This value is required to frequent On and Off of water tank heater.
- Value #2 of Function Code 29 : Determining heating demand priority between sanitary water tank heating and under floor heating.
- Example : If user's target temperature is set as '70' and Value #1 is set as '3', then the water tank heater will be turned off when the water temperature is above 73 °C. The water tank heater will be turned on when the water temperature is below 70 °C.
- Example : If Value #2 is set as '0', that means heating priority is on sanitary water heating, sanitary water is heated by AWHP compressor cycle and water heater. In this case the under floor can not be heated while sanitary water heating. On the other hand, if the Value #2 is set as '1', that means heating priority is on under floor heating, sanitary tank is ONLY heated by water heater. In this case the under floor heating is not stopped while sanitary water is heated.

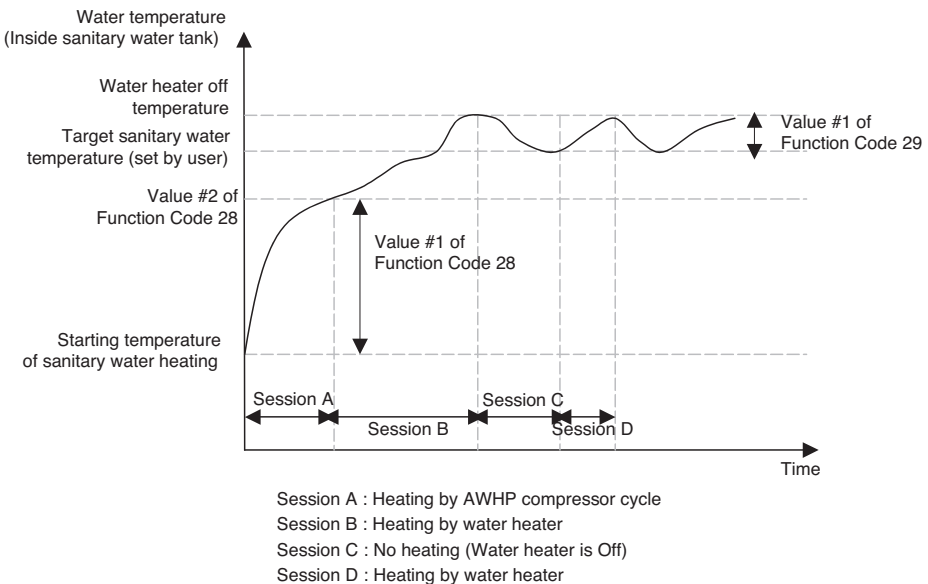

NOTICE

Sanitary water heating does not operate when it is disabled.

Enabling / Disabling of sanitary water heating is determined by pushing  button.

When  icon is displayed on the remote controller, sanitary water heating is enabled. (by button input or scheduler programming)

• **Function Code 2A** : Miscellaneous setting

- Value #1 of Function Code 2A : determine electric heater and sanitary tank heater on and off.
- Value #2 of Function Code 2A : not used.
- Example : If Value #1 is set as '0', then electric heater and sanitary tank heater are on and off according to control logic. If Value #1 is set as '1', then electric heater is never turned on and only water heater is on and off according to control logic.

• **Function Code 2B** : Sanitary water heating timers

Determine following time duration : operation time of sanitary tank heating, stop time of sanitary tank heating, and delay time of sanitary tank heater operating.

- Value #1 of Function Code 2B : This time duration defines how long time sanitary tank heating can be continued.
- Value #2 of Function Code 2B : This time duration defines how long time sanitary tank heating can be stopped. It is also regarded as time gap between sanitary tank heating cycle.
- Value #3 of Function Code 2B : This time duration defines how long time sanitary tank heater will not be turned on in sanitary water heating operation.
- Example of timing chart :

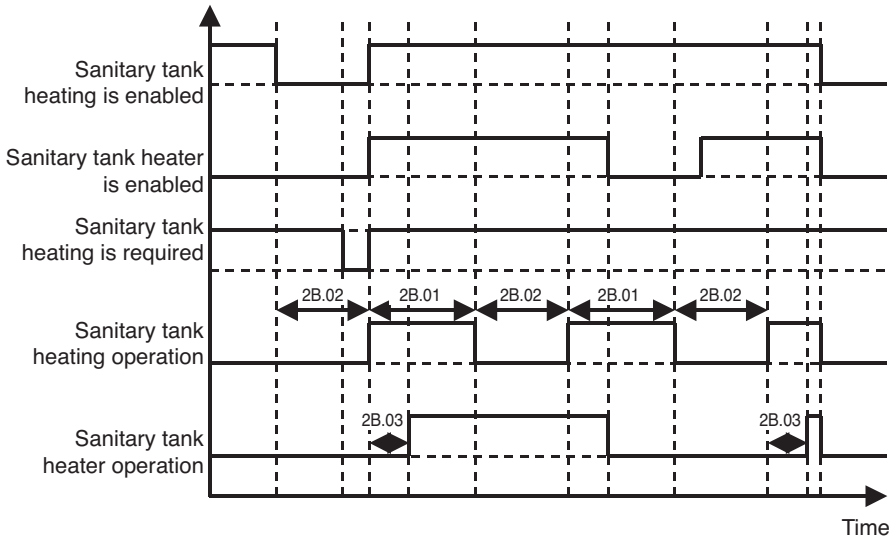

7. Check Points, Maintenance and Troubleshooting

If everything is going well until now, it is time to start the operation and to take advantages of **THERMAV**.

Before starting operation, pre-check points are described in this chapter. Some comments about maintenance and how to do troubleshooting are presented.

Check List before Starting Operation

CAUTION

Turn off the power before changing wiring or handling unit.

No	Category	Item	Check Point
1	Electricity	Field wiring	<ul style="list-style-type: none"> All switches having contacts for different poles should be wired tightly according to regional or national legislation. Only qualified person can proceed wiring. Wiring and local-supplied electric parts should be complied with European and regional regulations. Wiring should be following the wiring diagram supplied with the unit.
2		Protective devices	<ul style="list-style-type: none"> Install ELB (earth leakage breaker) with 30 mA.
3		Earth wiring	<ul style="list-style-type: none"> Earth should be connected. Do not earth to gas or city water pipe, metallic section of a building, surge absorber, etc.
4		Power supply	<ul style="list-style-type: none"> Use dedicated power line.
5		Terminal block wiring	<ul style="list-style-type: none"> Connections on the terminal block (inside of the unit) should be tightened.
6	Water	Charged water pressure	<ul style="list-style-type: none"> After water charging, the pressure gage (in front of the unit) should indicate 200~250 kPa. Do not exceed 300 kPa.
7		Air purge	<ul style="list-style-type: none"> During water charging, air should be taken out through the hole of the air purge. If water does not splash out when the tip (at the top of the hole) is pressed, then air purging is not completed yet. If well purged, the water will splash out like fountain. Be careful when testing air purge. Splashed water may make your dress wet.
8		By-pass valve	<ul style="list-style-type: none"> By-pass valve should be installed and adjusted to secure enough water flow rate. If water flow rate is low, flow switch error (CH14) can be occurred.
9	Unit Installation	Parts inspection	<ul style="list-style-type: none"> There should be no apparently damaged parts inside the unit.
10		Refrigerant leakage	<ul style="list-style-type: none"> Refrigerant leakage degrades the performance. If leakage found, contact qualified LG air conditioning installation person.
11		Drainage treatment	<ul style="list-style-type: none"> While cooling operation, condensed dew can drop down to the bottom of the unit. In this case, prepare drainage treatment (for example, vessel to contain condensed dew) to avoid water drop.

Maintenance

To assure best performance of **THERMAV**, it is required to perform periodical check and maintenance. It is recommended to proceed following check list for once a year.

⚠ CAUTION

Turn off the power before proceeding maintenance

No	Category	Item	Check Point
1	Water	Water pressure	<ul style="list-style-type: none"> • In normal state, the pressure gage (inside of the unit) should indicate 200~250 kPa. • If the pressure is less than 30 kPa, please recharge the water.
2		Strainer(Water filter)	<ul style="list-style-type: none"> • Disassemble strainer. Then wash the strainer to make it clean. • While disassembling the strainer, be careful for water flood out.
3		Safety valve	<ul style="list-style-type: none"> • Open the switch of the safety valve and check if water is flood out through the drain hose. • After checking, close the safety valve.
4	Electricity	Terminal block wiring	<ul style="list-style-type: none"> • Look and inspect if there is loosen or defected connection on the terminal block.

Test Run

Check before Test run

1	Check to see whether there is any refrigerant leakage, and check whether the power or transmission cable is connected properly.
2	<p>Confirm that 500 V megger shows 2.0 MΩ or more between power supply terminal block and ground. Do not operate in the case of 2.0 MΩ or less.</p> <p>NOTE: Never carry out mega ohm check over terminal control board. Otherwise the control board may break.</p> <p>Immediately after mounting the unit or after leaving it turned off for an extended length of time, the resistance of the insulation between the power supply terminal board and the ground may decrease to approx. 2.0 MΩ as a result of refrigerant accumulation in the internal compressor.</p> <p>If the insulation resistance is less than 2.0 MΩ, turn on the main power supply.</p>

Test run flow chart

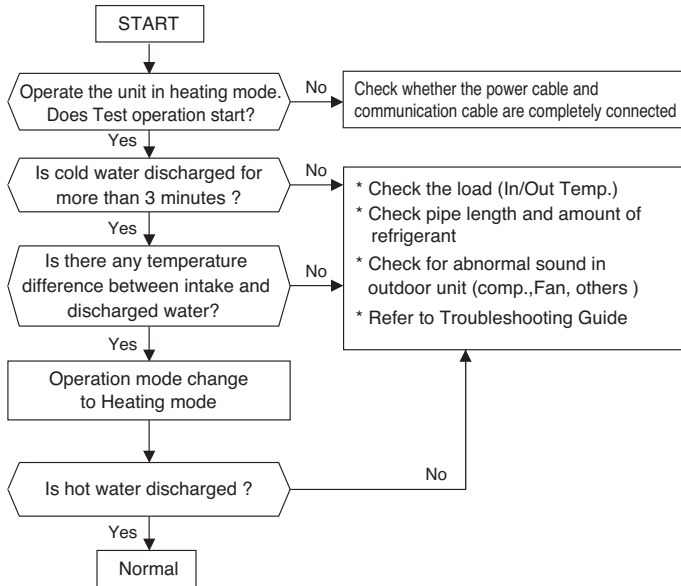

Airborne Noise Emission

The A-weighted sound pressure emitted by this product is below 70 dB.

** The noise level can vary depending on the site.

The figures quoted are emission level and are not necessarily safe working levels.

Whilst there is a correlation between the emission and exposure levels, this cannot be used reliably to determine whether or not further precautions are required.

Factor that influence the actual level of exposure of the workforce include the characteristics of the work room and the other sources of noise, i.e. the number of equipment and other adjacent processes and the length of time for which an operator exposed to the noise.

Also, the permissible exposure level can vary from country to country.

This information, however, will enable the user of the equipment to make a better evaluation of the hazard and risk.

Limiting concentration

Limiting concentration is the limit of Freon gas concentration where immediate measures can be taken without hurting human body when refrigerant leaks in the air.

The limiting concentration shall be described in the unit of kg/m^3 (Freon gas weight per unit air volume) for facilitating calculation.

Limiting concentration: 0.44kg/m^3 (R410A)

■ Calculate refrigerant concentration

$$\text{Refrigerant concentration} = \frac{\text{Total amount of replenished refrigerant in refrigerant facility (kg)}}{\text{Capacity of smallest room where indoor unit is installed (m}^3\text{)}}$$

Vacuum & Charge of Refrigerant

By default, the product was charged of refrigerant.
Vacuum and refrigerant charge, If there is leak refrigerant.

1. Vacuum

To work of vacuum action. when the leak of refrigerant.

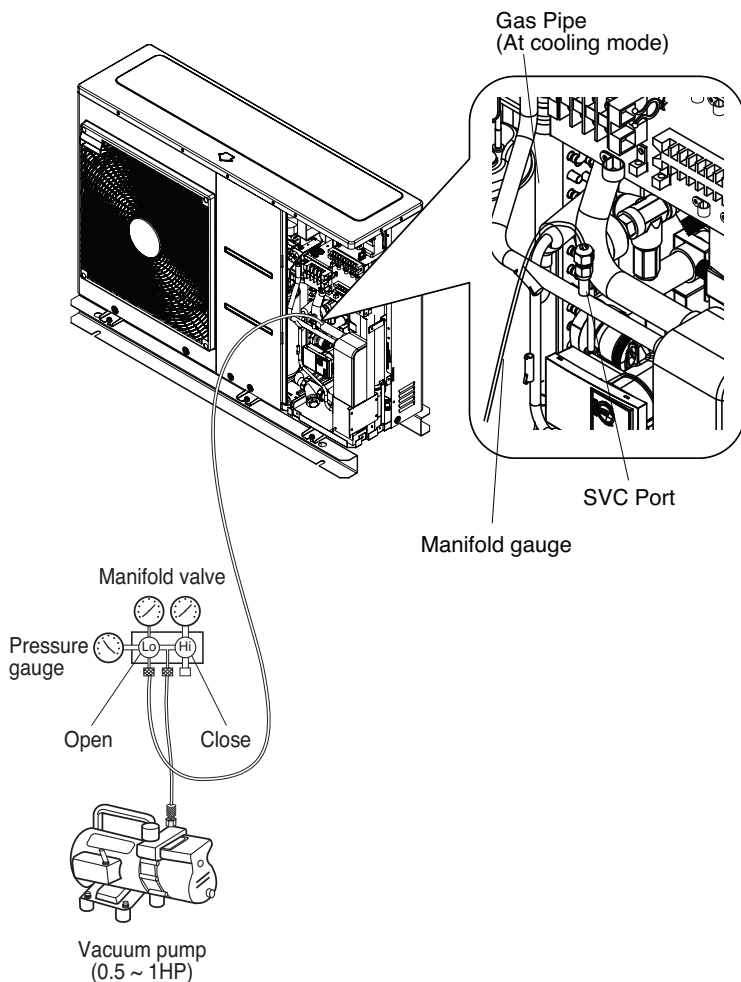

When selecting a vacuum, you should select one which is capable of achieving 0.2 Torr of ultimate vacuum.

Degree of vacuum is expressed in Torr, micron, mmHg, and Pascal (Pa). The units correlate as follows:

	Unit	Standard atmospheric pressure	Perfect vacuum
Gauge Pressure	Pa	0	-1.033
Absolute Pressure	Pa	1.033	0
Torr	Torr	760	0
Micron	Micron	760000	0
mmHg	mmHg	0	760
Pa	Pa	1013.33	0

2. Charge of refrigerant

You should be charged after vacuum.

You can see amount of refrigerant at quality label.

Please to charge at cooling mode when there is not full charging.

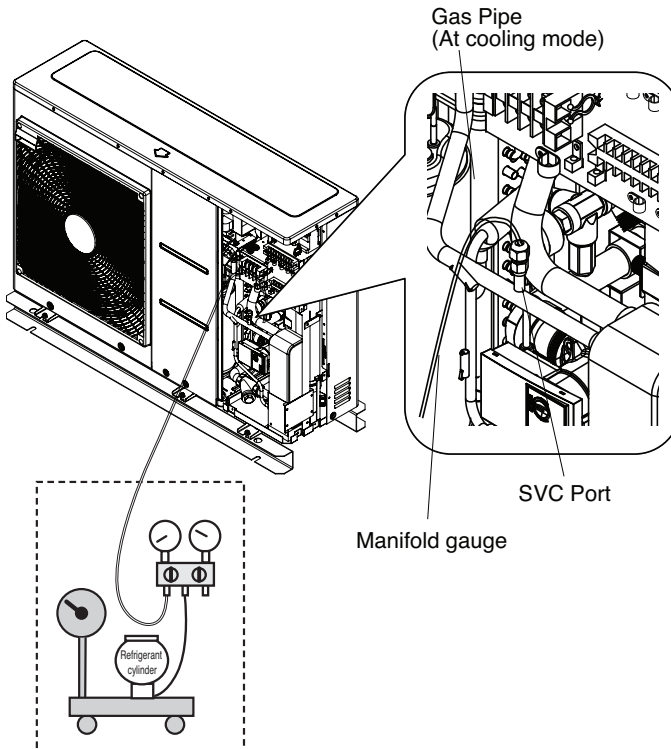

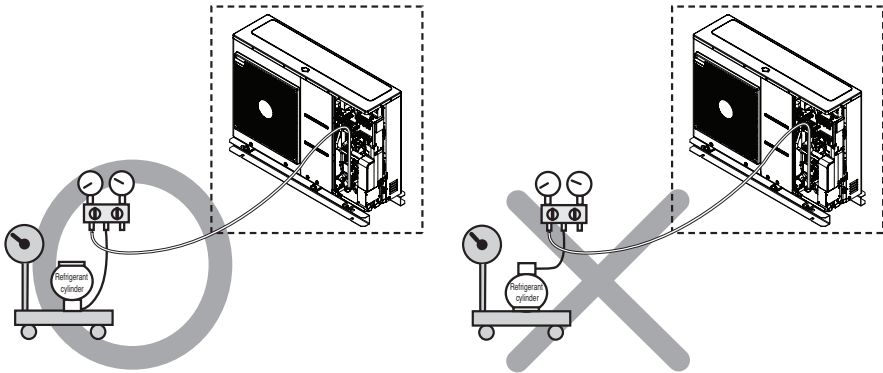

3. Location of SVC port

AHBW056A0/AHBW076A0/AHBW096A0

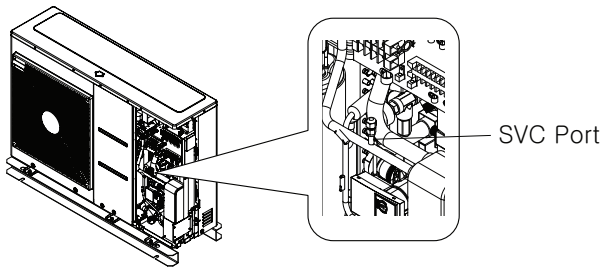

AHBW126A0/146A0/166A0
128A0/148A0/168A0

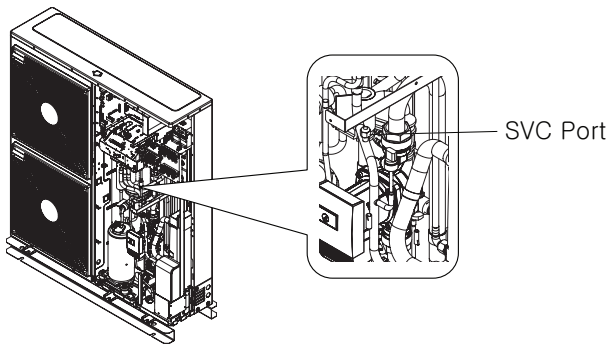



Troubleshooting

If the Heat Pump operates not properly or it does not start operation, please check following list.

⚠ CAUTION

Turn off the power before proceeding troubleshooting.

Troubleshooting for problem while operation

No	Problem	Reason	Solution
1	Heating or cooling is not satisfactory.	• Setting target temperature is not proper.	• Set target temperature correctly. • Check if temperature is water-based or air-based. See Function code 03 and 05 in Chapter 6.
		• Charged water is not enough.	• Check pressure gage and charge more water until pressure gage is indicating 200~250 kPa.
		• Water flow rate is low.	• Check if strainer gathers too much particles. If so, strainer should be cleaned. • Check if internal water pump speed is NOT set as 'High'. It should be set as 'High.' • Check if pressure gage indicates above 30 kPa. • Check if water pipe is getting closed due to stacked particles or lime.
2	Although electric power supply is OK (remote controller displays information), the unit does not start working.	• Water inlet temperature is too high.	• If water inlet temperature is above 55 °C, the unit does not operated for the sake of system protection.
		• Water inlet temperature is too low.	• If water inlet temperature is below 5 °C, the unit does not operated for the sake of system protection. Wait while unit warms up the water inlet temperature.
3	Water pump noise.	• Air purging is not completely finished.	• Open the cap of air purge and charge more water until pressure gage is indicating 200~250 kPa. • If water does not splash out when the tip (at the top of the hole) is pressed, then air purging is not completed yet. If well purged, the water will splash out like fountain.
		• Water pressure is low.	• Check if pressure gage indicates above 30 kPa. • Check if the expansion tank and pressure gage operates well.
4	Water is flood out through drain hose.	• Too much water is charged.	• Flood out the water by opening the switch of the safety valve until pressure gage is indicating 200~250 kPa.
		• Expansion tank is damaged.	• Replace the expansion tank.
5	Sanitary water is not hot.	• Thermal protector of water tank heater is activated.	• Open the side panel of the sanitary water tank and push the reset button of the thermal protector. (for more detail information, please refer to installation manual of sanitary water tank.)
		• Sanitary water heating is disabled.	• Push  button and identify if  icon is displayed on the remote controller.

Troubleshooting for Error Code

Code No.	Description	Cause	Normal Condition
1	Problem in remote room air sensor	<ul style="list-style-type: none"> • Incorrect connection between sensor and PCB(Heater). • PCB(Heater) fault • Sensor fault 	<ul style="list-style-type: none"> • Resistance: 10 kΩ at 25 centigrade (unplugged) → for Remote room air sensor • Resistance: 5 kΩ at 25 centigrade (unplugged) → for all sensors EXCEPT remote room air sensor • Voltage: 2.5 V DC at 25 centigrade (plugged) (for all sensors) • Refer resistance-temperature table to check in different temperature
2	Problem in refrigerant (inlet side) sensor		
6	Problem in refrigerant (outlet side) sensor		
8	Problem in water tank sensor		
16	Problems in sensors		
17	Problem in water-inlet sensor		
18	Problem in water-outlet sensor		
19	Problem in water-interim sensor		
3	Bad communication between remote controller and unit.	<ul style="list-style-type: none"> • Incorrect connection between sensor and PCB(Heater) • PCB(Heater) fault • Sensor fault 	<ul style="list-style-type: none"> • Wire connection between remote controller and Main PCB assembly(Heater) should be tight • Output voltage of PCB should be 12 V DC
5	Bad communication between Main PCB assembly(Heater) and Main PCB assembly(Inverter) of the unit.	<ul style="list-style-type: none"> • The connector for transmission is disconnected • The connecting wires are misconnected • The communication line is broken • Main PCB assembly(Inverter) is abnormal • Main PCB assembly(Heater) is abnormal 	<ul style="list-style-type: none"> • Wire connection between remote control panel and Main PCB assembly(Heater) should be tight.
53			
9	PCB program (EEPROM) fault	<ul style="list-style-type: none"> • Electrical or mechanical damage a the EEPROM 	<ul style="list-style-type: none"> • This error can not be permitted
14	Problem in flow switch	<ul style="list-style-type: none"> • Flow switch is open while internal water pump is working • Flow switch is closed while internal water pump is not working • Flow switch is open while DIP switch No. 5 of Main PCB assembly(Heater) is set as on 	<ul style="list-style-type: none"> • Flow switch should be closed while internal water pump is working or DIP switch No. 5 of Main PCB assembly(Heater) is set as on • Flow switch should be open while internal water pump is not working
15	Water pipe overheated	<ul style="list-style-type: none"> • Abnormal operation of electric heater • Leaving water temperature is above 57 °C 	<ul style="list-style-type: none"> • If there is no problem in electric heater control, possible maximum leaving water temperature is 57 °C
20	Thermal fuse is damaged	<ul style="list-style-type: none"> • Thermal fuse is cut off by abnormal overheating of internal electric heater • Mechanical fault at thermal fuse • Wire is damaged 	<ul style="list-style-type: none"> • This error will not be happened if temperature of electric heater tank is below 80 °C

