



Scan the QR code to see the manual.



OWNER'S MANUAL

AIR PURIFIER



Before beginning installation, read these instructions carefully. This will simplify installation and ensure that the product is installed correctly and safely. Leave these instructions near the product after installation for future reference.

ENGLISH

AS10GBDY0, AS65GDBY0

TABLE OF CONTENTS

This manual may contain images or content that may be different from the model you purchased.
This manual is subject to revision by the manufacturer.

SAFETY INSTRUCTIONS

READ AND SAVE THESE INSTRUCTIONS 3
WARNING INSTRUCTIONS 3
CAUTION INSTRUCTIONS 7

OPERATION

Product Overviews 9
Preparation before Operation 12
Examining Features 14
Operating the Air Purifier 18
Using the Extra Functions 20
Overall Air Quality 23

SMART FUNCTIONS

LG ThinQ Application 24
Smart Diagnosis 25

MAINTENANCE

Maintaining the Product 27

TROUBLESHOOTING

Before Calling for Service 31

APPENDIX

Information 35

SAFETY INSTRUCTIONS

READ AND SAVE THESE INSTRUCTIONS

The following safety guidelines are intended to prevent unforeseen risks or damage from unsafe or incorrect operation of the appliance. The guidelines are separated into 'WARNING' and 'CAUTION' as described below.

Safety Messages



This symbol is displayed to indicate matters and operations that can cause risk.

Read the part with this symbol carefully and follow the instructions in order to avoid risk.



WARNING

This indicates that failure to follow the instructions can cause serious injury or death.



CAUTION

This indicates that failure to follow the instructions can cause minor injury or damage to the product.

WARNING INSTRUCTIONS

WARNING

- To reduce the risk of explosion, fire, death, electric shock, injury or scalding to persons when using this product, follow basic precautions, including the following:

Technical Safety

- This appliance is not intended for use by persons (including children) with reduced physical, sensory or mental capabilities or lack of experience and knowledge, unless they have been given supervision or instruction concerning use of the appliance by a person

responsible for their safety. Children should be supervised to ensure that they do not play with the appliance.

- The fan is not a toy. It should not be played with or placed where young children can reach it.
- If the supply cord is damaged, it must be replaced by the manufacturer, its service agent or similarly qualified person in order to avoid a hazard.
- Only an authorized repair person should disassemble, repair, or modify the appliance.
- Do not touch the power plug with wet hands.
- Do not place the power cord under rugs, carpeting or mats.
- Do not install and use broken parts.

Installation

- Do not install the appliance on an uneven or inclined surface.
- Do not install the appliance in an area exposed to direct sunlight or near heat-generating equipment.
- Do not install the product in a place where combustible gas may leak or industrial oil or metallic particulates are present.
- Do not allow the appliance to push against the power cord or plug.
- Do not bend the power cable excessively or place a heavy object on top of it.
- Do not extend the length of the power cable or alter it.
- Do not use several devices on a multi-socket extension outlet.
- Make the connection securely so that screw in terminals may not be loosened when the cable is pulled.
- Make sure that the power cable cannot be pulled out or damaged during operation.
- When unplugging the power cord, always pull it by the plug.
- Unplug the appliance during thunder or lightning storms or when not in use for a long time.

Operation

- If the appliance is immersed in water, stop using it and contact an LG Electronics Customer Information Center.
- If there is a gas leakage (isobutane, propane, LNG, etc.), do not touch the appliance or power plug and ventilate the area immediately.
- If you detect any abnormal noise, odor or smoke, unplug the appliance immediately and contact an LG Electronics Customer Information Center.
- Do not clean the appliance with brushes, cloths or sponges which are abrasive or made of metal.
- Do not use or store fire, combustibles (ether, benzene, alcohol, drugs, propane, butane, combustible spray, insecticide, air freshener, cosmetics, etc.) or flammable materials (candles, lamps, etc.) near the product.
- Do not allow animals or pets to chew on the power cord.
- Do not move the appliance when it is in operation.
- Do not hit the appliance.
- Do not insert hands or metal objects into the air inlet or outlet.
- Do not put flammables into the appliance.
- Do not move or operate the appliance while its cover is open.
- Do not allow children to climb on or play with the appliance.
- Do not place anything on top of the appliance.
- If the electrical appliance is visibly damaged, do not allow electrical appliances to work.

UVnano Function

NOTE

- This is only for models with the UVnano function. Models with the UVnano function are equipped with a UV-C lamp (UV LED) inside the product.

- This product uses UVnano LED. Do not disconnect or replace the UVnano LED arbitrarily. LEDs must be replaced only by LG-approved service providers.
- Harmful UVnano radiation may leak if the device is used in an unintended way or if the wires are damaged. UVnano radiation, even in very small amounts, can harm the eyes and skin.
- The UVnano LED is not a part that needs cleaning, so do not clean the UVnano LED or parts with the UV hazard label separately.
- If the UVnano LED is damaged, do not operate it.
- This appliance contains a UV emitter. Do not stare at the light source.
- Before replacing the UV-C emitter, electrical appliances must be cut off from the main power source.

Maintenance

- Dispose of the packing materials (vinyl, styrofoam, etc.) to keep them out of reach of children.
- Take care not to injure or pinch yourself when you detach and reattach parts of the appliance.
- Turn off and unplug the appliance before cleaning it or replacing the filter.

CAUTION INSTRUCTIONS

CAUTION

- To reduce the risk of minor injury to persons, malfunction, or damage to the product or property when using this product, follow basic precautions, including the following:

Installation

- Do not tilt the appliance to pull or push it when transporting.
- Do not install the appliance in a vehicle, RV, or marine vessel.
- Do not place the appliance near a TV or stereo equipment.
- Do not place the appliance under bright light.
- The appliance must be installed in accordance with national wiring regulations.
- When moving or storing the appliance, wrap the power cord around the base of the appliance to prevent personal injury, damage to the cord or damage to floors.
- Do not place the appliance near curtains.

Operation

- Before turning on electrical appliances, must read maintenance instructions.
- Do not use the product for removal of toxic gas such as carbon monoxide.
- Do not use the product for ventilation purposes.
- Do not use the appliance for a long time in a region with unstable voltage.
- Do not place obstacles around the air inlet or outlet.
- For safe use of the appliance, children or others with reduced mental capabilities need to be closely monitored by a person who is responsible for their safety.
- Do not use the product for special purposes such as preserving plants, precision instruments, artworks, etc.

- Do not operate the appliance with wet hands.
- Do not let the moisture from a humidifier directly touch the appliance.
- Do not use the appliance while it is not in an upright position.
- Do not use the appliance near objects vulnerable to heat.
- Do not use detergents, cosmetics, chemicals, air fresheners, or disinfectants in the appliance.
- Do not touch any internal parts while the unit is operating or immediately after operation.
- Use the filter only for its intended purpose.
- Do not forcefully separate the filters, as the filters are attached.
- Do not insert any objects in the air outlet.

Clean Booster

- Do not disassemble the clean booster.
- Do not insert any objects into the clean booster.
- Do not operate the product while the clean booster cover and grille are separated.
- Do not insert hands or metal objects into the moving parts of the clean booster.

Maintenance

- Do not use strong detergents or solvents to clean the appliance. Use a soft cloth to clean.
- Do not clean the appliance with an alkaline detergent.
- Do not wipe the appliance surface using sulfuric acid, hydrochloric acid or organic solvents (thinner, kerosene etc.) or attach a sticker on the appliance.
- Do not allow water inside the appliance.
- Do not wash the filter with water.
- Be careful not to damage the pre-filter when cleaning it with a vacuum cleaner.

OPERATION

- The exterior or components of the product may vary depending on the model.

Product Overviews

Front

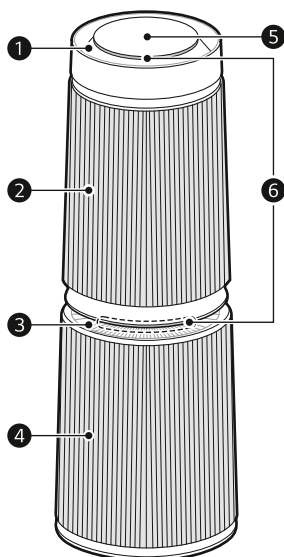

Dual Model

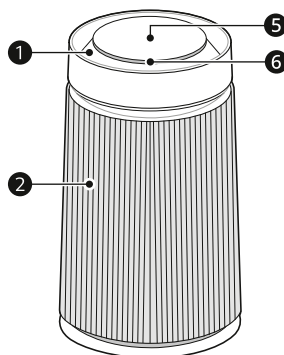

Single Model

1 Air Outlet (Top) / Clean Booster

- Purified air from the filter is emitted.
- Allows you to adjust the direction of wind emission.

2 Air Inlet (Top)

- Allows you to disassemble the front and the rear covers separately.

3 Bottom Air Outlet

- Purified air is emitted from the bottom filter.

4 Bottom Air Inlet

- Allows you to disassemble the front and the rear covers separately.

5 Status Panel/Control Panel

- Use it to check the settings of the appliance and the air quality.
- Use it to set the appliance functions.

6 Air Quality Light

- The current air quality is indicated by a color.

Back

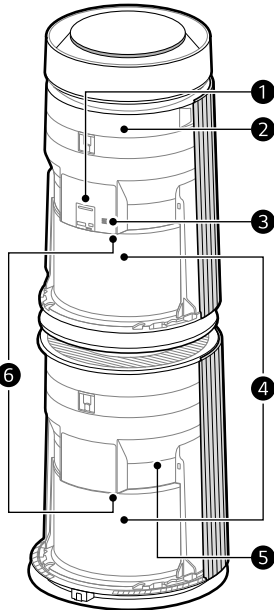

Dual Model

1 PM1.0 Sensor

- It detects the level of the concentration of particulate matter (PM).

2 Smart Diagnosis Panel

- When the product malfunctions or breaks down, the product status can be checked through **Smart Diagnosis**.

3 Odor (Gas) Sensor

- It detects a odor (gas).

4 Filter

- It eliminates fine particles, smog causing materials, sickening house syndrome materials, and domestic odor.

5 Ionizer

- Generate ions to minimize various bacteria from the air.

6 UVnano LED

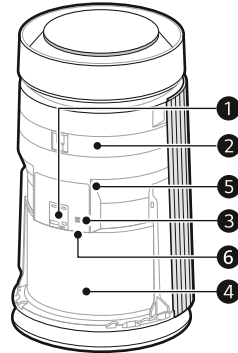

Single Model

- Remove the harmful bacteria at internal fan of the air purifier.

Filter

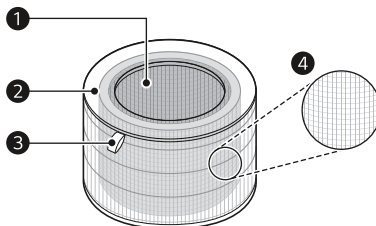

1 Photocatalytic (Deodorization) Filter

- Minimizes smog causing materials (SO₂, NO₂), sickening house syndrome materials (toluene, formaldehyde), domestic odor, and sulphur compounds.

2 Dust Collection Filter

- Minimizes PM1.0, allergen materials, bacterial and viral from the air.

3 Filter Handle

- Allows you to separate the filter from the product.

4 Pre-Filter

- Minimizes large particles floating in the air.

⚠ CAUTION

- Do not forcefully separate the filters, as the filters are attached.
- Do not throw the filters or use them for other purposes.

Components



1

- 1 Owner's Manual

Preparation before Operation

Removing the Protective Vinyl from the Filter

Unpack the appliance and remove all packing tape and filter vinyl before using the appliance.

- 1 Take the product out of the box, and remove the vinyl or the fixing tape attached to the product.
- 2 Hold the top of the rear cover of the product and pull it slightly to achieve separation.

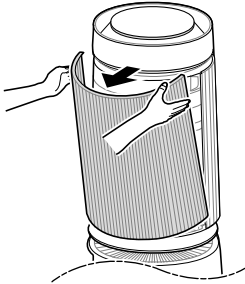

- 3 Remove the packing support (1) from near the filter inlet.

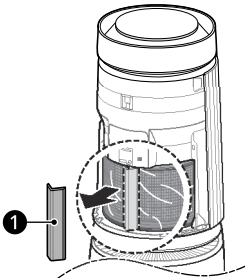

- 4 Disassemble the filter and remove the vinyl.

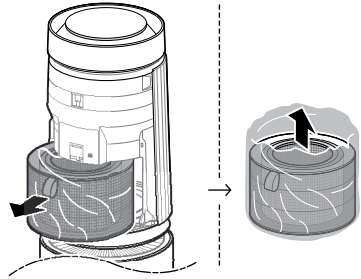

- 5 Install the filter in the appliance.

- Install it with the side where the handle (2) is attached facing up.

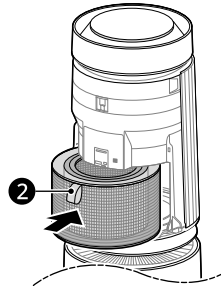

- 6** Insert the fixing part at the bottom of the cover into the fixing grooves at the bottom of the product and close the cover.

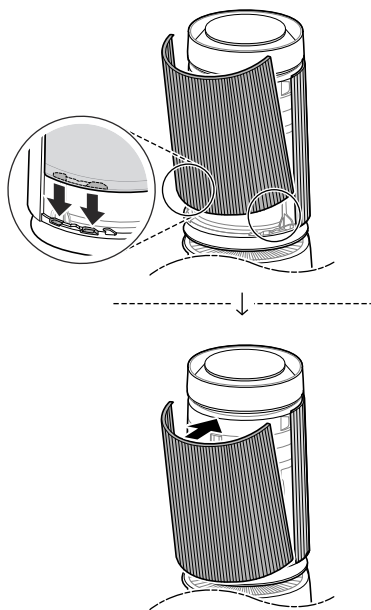

- The air inlet needs sufficient space to function properly.

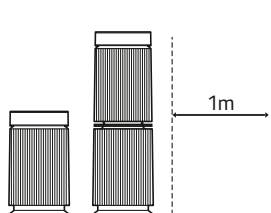

- The performance of the appliance may vary depending on the service environment (temperature, humidity, etc.).
 - The appliance can provide the guaranteed performance in an environment with humidity ranging between 40 % and 70 %.

Transportation Requirements

When you relocate or store the appliance, wind the power cord onto the bottom of the product to prevent it from dragging on the floor.

- Failure to do so may damage the power plug or leave a scratch on the floor.

When carrying the product

- Do not carry the product by holding the external cover. Doing so may allow the cover to open and the product to drop. Dropping the appliance may cause personal injury or product malfunction.

Single Model

Transport the product safely by holding the bottom of the product with both hands.

Dual Model

Transport the product safely by having two people hold the central part of the product.

⚠ CAUTION

- In case of the dual model, remove the support and the vinyl of the filter at the bottom of the air purifier in the same way.
- Be sure to remove the filter packing support and the vinyl before using the product. Failure to do so may cause product malfunction.
- Pay attention to filter direction when installing it. Failure to do so may cause product malfunction and failure.

Installation Location Requirements

Install the appliance 1 m away from a wall.

Examining Features

Controlling the Air Purifier

Control Panel

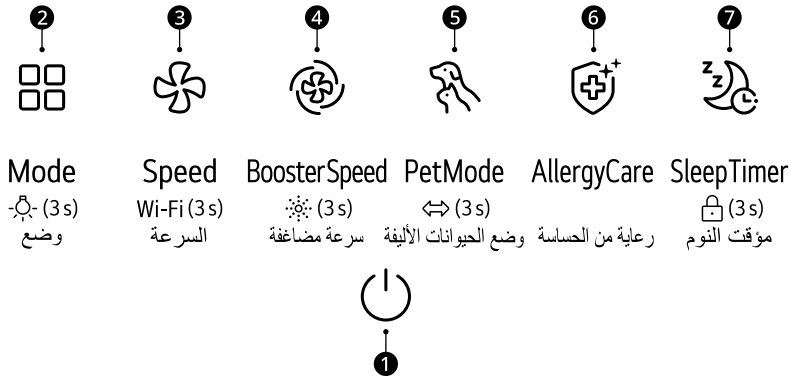

1 Start/Stop Button

Use it to turn the product on or off.

2 Mode Button

Use it to set the mode.

• Light

- Press and hold it for 3 seconds or more to turn on/off the air quality light.

3 Speed Button

Use it to adjust the fan speed of the air purifier.

• Wi-Fi Function

- Before appliance connection: Press and hold the button for 3 seconds to activate the Wi-Fi connection mode.
- Wi-Fi function off: Press and hold the **Start/Stop** button and the **Speed** button simultaneously for 3 seconds or more.

4 Booster Speed Button

Use it to adjust the fan speed of the clean booster.

• Indicator

- Press and hold it for 3 seconds or more to check the concentration of PM by its particle size. (PM10 → PM2.5 → PM1.0)

5 Pet Mode Button

Use it operating Pet Mode.

• Swing

- Press and hold it for 3 seconds or more to adjust the rotation direction of the clean booster to the left or the right.

6 Allergy Care Button

Allows you to use the Allergy Care function.

7 Sleep Timer Button

Allows you to use the sleep timer function.

- **Lock**

- Press and hold it for 3 seconds or more to lock or unlock the control panel buttons.

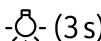
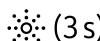
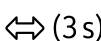
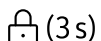
Long key buttons				
 (3 s)	Wi-Fi (3 s)	 (3 s)	 (3 s)	 (3 s)
Light	Wi-Fi Function	Indicator	Swing	Lock

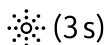
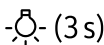
**Status Panel**

[Dual Model]

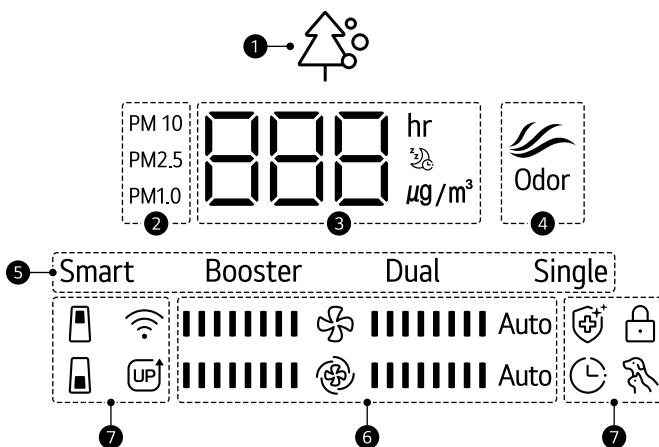

① Overall Air Quality (Color)



② The size of dust particles and the concentration of PM (color)

③ The concentration of PM and sleep timer

④ The concentration of odor (color)









⑤ Display operating mode

⑥ Display speed and booster speed

-  Speed : Displays the air purifier's fan speed.
-  Booster Speed : Displays the clean booster's fan speed.

⑦ Icons



16 OPERATION



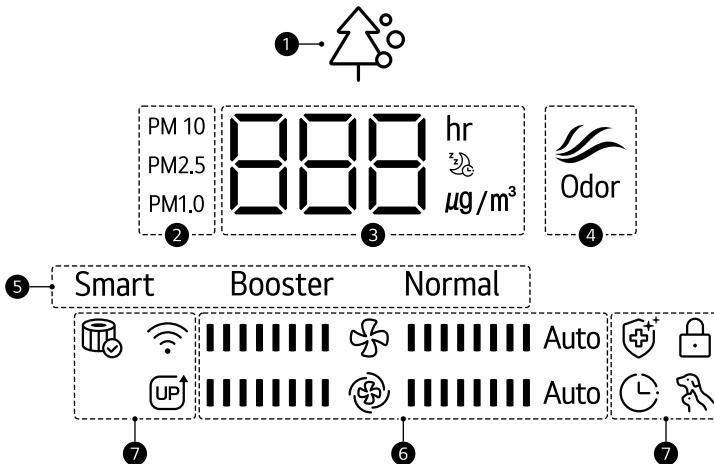



Icon	Description
	Lights up when it is time to replace the top filter.
	Lights up when it is time to replace the bottom filter.
	Lights up when the Wi-Fi function is activated.
	Lights up when there are new features that can be upgraded.
	Lights up when the Allergy Care function is activated.
	Lights up when On/Off Timer is set through the LG ThinQ Application.
	Lights up when the lock function is set.
	Lights up when the Pet Mode is activated.

[Single Model]



- ❶ Overall Air Quality (Color)
- ❷ The size of dust particles and the concentration of PM (color)
- ❸ The concentration of PM and sleep timer
- ❹ The concentration of odor (color)

- 5 Display operating mode
- 6 Display speed and booster speed
 -  Speed : Displays the air purifier's fan speed.
 -  Booster Speed : Displays the clean booster's fan speed.
- 7 Icons

Icon	Description
	Lights up when it is time to replace the filter.
	Lights up when the Wi-Fi function is activated.
	Lights up when there are new features that can be upgraded.
	Lights up when the Allergy Care function is activated.
	Lights up when On/Off Timer is set through the LG ThinQ Application.
	Lights up when the lock function is set.
	Lights up when the Pet Mode is activated.

Operating the Air Purifier

Start/Stop

Press the **Start/Stop** button to turn on or off the air purifier.

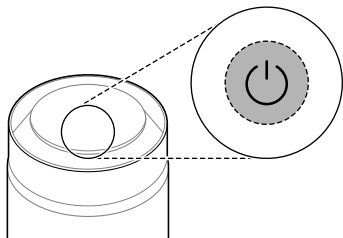

NOTE

- When the operation is started for the first time, the appliance operates in **Booster** mode.
- The most recently used mode is memorized if the power supply is cut off as a result of a power failure.
- When the operation begins, the display of sensor ready will appear for approximately 30 seconds.

Operating Mode

Each time you press the **Mode** button, the mode changes in the following order.

- Single Model : **Smart** → **Booster** → **Normal**.
- Dual Model : **Smart** → **Booster** → **Dual** → **Single**.

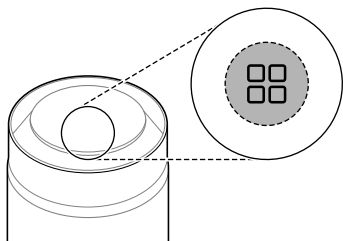

Smart Mode

Operating mode and fan speed are adjusted automatically according to overall air quality.

NOTE

- When the appliance is operated in **Smart** mode, **Speed**, **Booster Speed**, and **Swing** buttons are not operated.

Booster Mode

Clean Booster circulates the indoor air by quickly sending purified air over an extended distance.

⚠ CAUTION

- Be careful not to allow your hands to be pinched by the moving parts of the clean booster.

NOTE

- When the power cord is unplugged before the clean booster is completely closed, plug the cord in again. The clean booster will rotate and properly close.

Rotating the Clean Booster

Press the **Pet Mode** button for 3 seconds or more during operation in **Booster** mode.

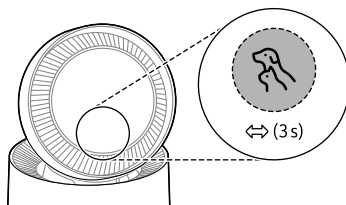

Dual Mode: Only for the relevant product

The product operates air purifiers at the top and bottom simultaneously to purify indoor air quickly.

Single Mode: Only for the relevant product

The air purifier at the bottom purifies indoor air.

- The air purifier at the top operates at a low speed.

Normal Mode: Only for the relevant product

As a basic operation mode for air purification, air speed can be adjusted.

Adjusting the Fan Speed

Adjust the fan speed of the air purifier.

Press the **Speed** button during the operation.

- Each time you press the button, the speed changes in the following order: Auto → Low → Middle → High → Turbo.

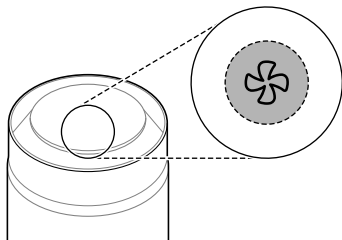

Fan Speed Display

When you adjust the speed, the speed will be displayed on the status panel. The speed increases by 2 columns each time when the level is raised.

- [Example of 'Middle' Display for Speed]



NOTE

- When the operation is started for the first time, the speed is set to Auto. In Auto mode, the speed is adjusted automatically according to the contamination level of indoor air.

Adjusting the Booster Speed

Adjust the fan speed of the clean booster.

Press the **Booster Speed** button during the **Booster** mode operation.

- Each time you press the button, the speed changes in the following order: Auto → Low → Middle → High → Turbo.

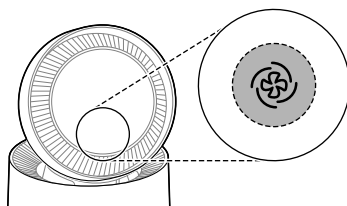

Booster Speed Display

When you adjust the booster speed, the booster speed will be displayed on the status panel. The booster speed increases by 2 columns each time the level is raised.

- [Example of 'Middle' Display for Booster Speed]



NOTE

- When the Auto mode is selected, clean booster speed is automatically adjusted to the same level as speed.

Using Pet Mode

This is a dedicated mode for pet owners.

This mode effectively inhales pet hair/dust by automatically adjusting Speed and air flow according to overall air quality.

Press the **Pet Mode** button during operation.

- 🐾 (Pet Mode) icon is shown in the status panel.

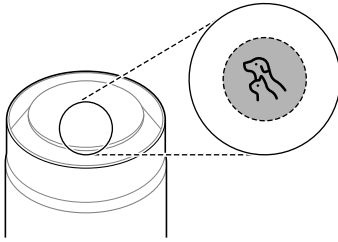

NOTE

- You can turn off the Pet Mode function in the same way as it is turned on.
- You can also change the operation mode to a desired mode by pressing the **Mode** button while Pet Mode is activated.
- Pet Mode becomes disabled when the **Sleep Timer** button is pressed while Pet Mode is activated.
- After operating 'Turbo' mode for 30 minutes, Speed is automatically adjusted according to air quality.
- Air flow can be adjusted by pressing the **Speed** button while Pet Mode is activated.
 - Each time you press the **Speed** button, the speed changes in the following order: Auto → Middle → High → Turbo.

Using the Extra Functions

Using the Allergy Care

Allergy Care refers to a function that combines the Ionizer and UVnano.

Press the **Allergy Care** button during operating.

- Allergy care icon is displayed on the status panel.

Ionizer

To generate ions to minimize various bacteria from the air.

UVnano

The fan for producing wind in the product is sterilized with UVnano LED, so you can use the product without concern.

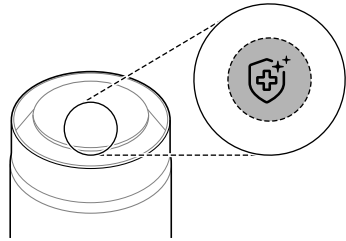

NOTE

- UVnano is a compound word of "UV" LEDs that reduce harmful bacteria and "nanometers" as in the ultraviolet wavelength unit.
- If UVnano is enabled, the UVnano LED will operate at certain intervals to sterilize the internal fan while the air purifier is operating.
- UVnano fan sterilization stops if you turn off the air purifier.

Setting the Sleep Timer

Stops the operation automatically after the operation for the set time.

Press the **Sleep Timer** button during operation.

- Each time you press the button, the setting changes in the following order: **After 2 hours** → **After 4 hours** → **After 8 hours** → **After 12 hours** → **Cancel**.
- When the sleep timer is activated, only the sleep timer icon is displayed on the status panel.

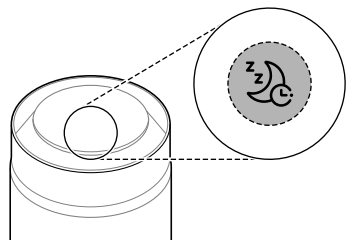

NOTE

- The speed is changed to the 'Low' level, and after a set period of time, the speed is adjusted automatically according to the air quality.
- The fan speed can be adjusted by pressing the **Speed** button while the sleep timer is activated.
- On the sleep timer setting, you can check the set time by pressing the **Sleep Timer** button again.
- The sleep timer setting will be maintained when the appliance is turned off and then on again as the result of a power failure.

Setting Control Panel Lock

You can lock the buttons on the control panel to prevent the appliance from operating due to unforeseen reasons, such as a child manipulating the buttons.

Press the **Sleep Timer** button for 3 seconds or longer during operation.

-  (Lock) is displayed on the status panel.

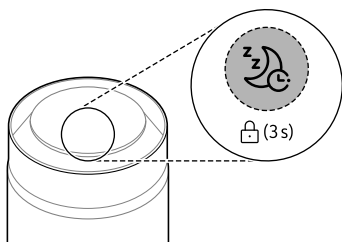
**NOTE**

- You can turn off the lock function in the same way as turning it on.
- You can also lock or unlock when the operation has stopped.

Setting the Air Quality Light

You can check the overall air quality through the air quality light.

Press the **Mode** button for 3 seconds or longer during operation.

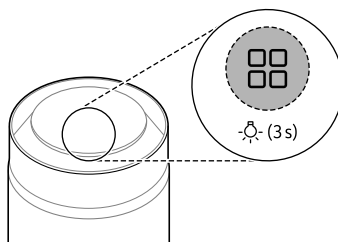
**NOTE**

- The air quality light turns white during sensor stabilization time (30 seconds). The odor (gas) sensor can be stabilized 2 minutes after its operation.

Checking the Concentration of PM

You can check the concentration of PM in the air by measuring the size of dust particles.

Press the **Booster Speed** button for 3 seconds or longer during operation.

- Each time you press the button, the setting changes in the following order: **PM10** → **PM2.5** → **PM1.0**.
- The selected PM concentration will be displayed for about 10 seconds.

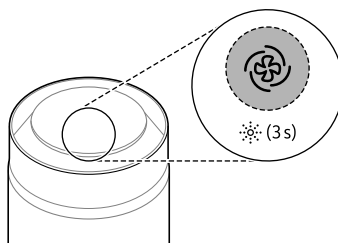
**NOTE**

- The overall air quality level is a result of both PM concentration and the odor level.

NOTE

- Whether it is a different product or the same product used in the same space, the concentration measurement may vary due to air circulation.
 - Unlike odors (gas), dust particles travel slowly. Therefore, the measured concentration may be lower than the actual concentration.
 - Air flow near the particles sensor may interrupt normal operation of the particles sensor and indicated PM concentration may be different from actual PM concentration, accordingly.
 - When the product is used in the following environment, the measured concentration of PM may differ from the actual concentration.
 - Near fabric sofas and beds, around hairy carpets, while making beds/folding clothes, while using vacuum cleaners, places with bugs and pets, and places with high humidity
 - Places where outside air is available, such as construction sites, roadsides, and factories, or near outside doors, windows, and vents
 - Places where products generating steam or fine particles (humidifiers, kitchen tools, or sprays) are used
 - The sensor may not detect particles larger than PM10 generated by activities such as dusting off blankets or cleaning, but they are removed by the filter.
 - The concentration of odors (gas) may vary due to items emitting odors such as air fresheners, deodorizers, detergents, or cosmetics.
-

Overall Air Quality

Understanding Overall Air Quality

The overall air quality is calculated based on the particles and odor (gas) concentrations and is categorized in 4 levels depending on the contamination of the air.

color	Overall air quality	Concentration of PM ($\mu\text{g}/\text{m}^3$)			Concentration of odor	
	State	PM10	PM2.5	PM1.0	State	Level
Red	Poor	255 or more	56 or more	56 or more	Very strong	4
Orange	Unhealthy	155 ~ 254	36 ~ 55	36 ~ 55	Strong	3
Yellow	Moderate	55 ~ 154	13 ~ 35	13 ~ 35	Normal	2
Green	Good	54 or less	12 or less	12 or less	Weak	1

NOTE

- The color of the overall air quality is based on the worst level detected, whether odors or particulates.
- PM (particulate matter) concentration is displayed in increments of 1 unit, from 8 to 999. PM concentration values are based on the data sheet provided by the sensor manufacturer.
- The PM concentration measurement was tested using LG Electronics' standard test materials.
- Differences in PM concentration values may be the result of different methods of measuring or differences in the actual PM concentration levels.
 - If the PM concentration is high, there may be a larger difference between the displayed concentration and the actual concentration.

SMART FUNCTIONS

LG ThinQ Application

The **LG ThinQ** application allows you to communicate with the appliance using a smartphone.

LG ThinQ Application Features

Smart Diagnosis

If you experience a problem while using the appliance, this **Smart Diagnosis** feature will help you diagnose the problem.

Settings

Allows you to set various options on the appliance and in the application.

NOTE

- In the following cases, you must update the network information for each appliance in the **LG ThinQ** application under **Device Cards** → **Settings** → **Change Network**.
 - wireless router is changed
 - wireless router password is changed
 - Internet service provider is changed
- The application is subject to change for appliance improvement purposes without notice to users.
- Functions may vary by model.

Installing LG ThinQ Application and Connecting an LG Appliance

Models with QR Code

Scan the QR code attached to the product using the camera or a QR code reader application on your smartphone.



Models without QR Code

- 1 Search for and install the **LG ThinQ** application from the Google Play Store or Apple App Store on a smartphone.
- 2 Run the **LG ThinQ** application and sign in with your existing account or create an LG account to sign in.
- 3 Touch the add (+) button on the **LG ThinQ** application to connect your LG appliance. Follow the instructions in the application to complete the process.

NOTE

- To verify the Wi-Fi connection, check that the Wi-Fi indicator on the control panel is lit.
- The appliance supports 2.4 GHz Wi-Fi networks only. To check your network frequency, contact

your Internet service provider or refer to your wireless router manual.

- **LG ThinQ** is not responsible for any network connection problems or any faults, malfunctions, or errors caused by network connection.
- The surrounding wireless environment can make the wireless network service run slowly.
- If the distance between the appliance and the wireless router is too far, the signal strength becomes weak. It may take a long time to connect or installation may fail.
- If the appliance is having trouble connecting to the Wi-Fi network, it may be too far from the router. Purchase a Wi-Fi repeater (range extender) to improve the Wi-Fi signal strength.
- The network connection may not work properly depending on the Internet service provider.
- The Wi-Fi connection may not connect or may be interrupted because of the home network environment.
- The appliance cannot be connected due to problems with the wireless signal transmission. Unplug the appliance and wait about a minute before trying again.
- If the firewall on your wireless router is enabled, disable the firewall or add an exception to it.
- The wireless network name (SSID) should be a combination of English letters and numbers. (Do not use special characters.)
- Smartphone user interface (UI) may vary depending on the mobile operating system (OS) and the manufacturer.
- If the security protocol of the router is set to **WEP**, you may fail to set up the network. Please change it to other security protocols (**WPA2** is recommended) and connect the product again.

- This function is available after registering the product in the **LG ThinQ** Application.

Open Source Software Notice Information

To obtain the source code that is contained in this product, under GPL, LGPL, MPL, and other open source licenses that have the obligation to disclose source code, and to access all referred license terms, copyright notices and other relevant documents, please visit <https://opensource.lge.com>.

LG Electronics will also provide open source code to you on CD-ROM for a charge covering the cost of performing such distribution (such as the cost of media, shipping, and handling) upon email request to opensource@lge.com.

This offer is valid to anyone in receipt of this information for a period of three years after our last shipment of this product.

Smart Diagnosis

Use this feature to help you diagnose and solve problems with your appliance.

NOTE

- For reasons not attributable to LGE's negligence, the service may not operate due to external factors such as, but not limited to, Wi-Fi unavailability, Wi-Fi disconnection, local app store policy, or app unavailability.
- The feature may be subject to change without prior notice and may have a different form depending on where you are located.

Upgrading the Product

When a new function that can be upgraded is available, **UP** icon will turn on the status panel when you turn on the product.

- From the menu on the **LG ThinQ** Application, you can upgrade the function by pressing **Feature Updates**.

Using LG ThinQ to Diagnose Issues

If you experience a problem with your Wi-Fi equipped appliance, it can transmit troubleshooting data to a smartphone using the **LG ThinQ** application.

- Launch the **LG ThinQ** application and select the **Smart Diagnosis** feature in the menu. Follow

the instructions provided in the **LG ThinQ** application.

Using Audible Diagnosis to Diagnose Issues

Follow the instructions below to use the audible diagnosis method.

- Launch the **LG ThinQ** application and select the **Smart Diagnosis** feature in the menu. Follow the instructions for audible diagnosis provided in the **LG ThinQ** application.

- 1** Press and hold the **Allergy Care** button for 5 seconds to execute the **Smart Diagnosis** function.

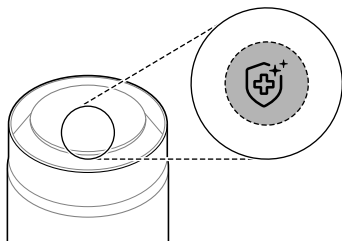

- 2** Place your smartphone near the product.
 - Make sure the microphone of the smartphone faces the front of the product.

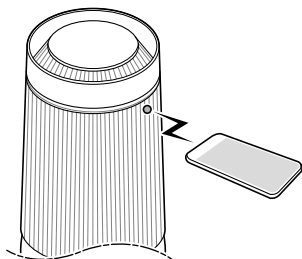

- 3** When data transmission is complete, the **Smart Diagnosis** result will be displayed on the **LG ThinQ** Application.

NOTE

- For accurate diagnosis, do not move the smartphone away from the product until the beeping stops.
 - Keep quiet around the product during **Smart Diagnosis**.
-



MAINTENANCE

Maintaining the Product

Scheduled maintenance

⚠ WARNING

- Be sure to stop the appliance operation and remove the power plug from the outlet before cleaning and replacing the filter.
- Do not spray water directly on the appliance.



Component	Cleaning frequency	Replacement frequency
 Filter	Pre-filter Clean filter as needed	1 year
 PM 1.0 sensor	2 months	-

NOTE

- The cleaning frequency may vary depending on the operating hours and environment of the appliance.
- If you do not clean the product according to the cleaning frequency, you may experience a bad odor and poor performance.
- The filter must be replaced at the end of its lifespan, and the cost of replacement filters is not covered under the warranty. To purchase new filters, contact an LG Electronics Customer Information Center or visit the website at www.lg.com

- If the PM concentration does not change on the display for a long time, clean the PM1.0 sensor even if it is not scheduled for a cleaning.

Alerts on the Status Panel

Model	Alert	Measures
Single		Replace the filter.
Dual		Replace the top purifier filter.
		Replace the bottom filter.

NOTE

- Filter replacement alerts appear based on the maximum usage time, taking into account the operating hours of the appliance. The replacement frequency is determined by the operating hours and environment.

Cleaning the Exterior

- 1 Remove any dust from the air inlet and outlet using a vacuum cleaner.

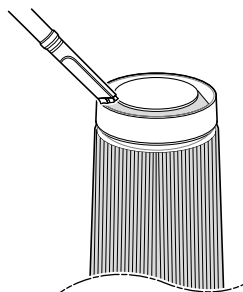

- 2 Wipe the exterior with a soft lint-free cloth.

⚠ CAUTION

- Do not wipe the appliance with an alkaline detergent.
- Never use sulphuric acid, hydrochloric acid or organic solvent (e.g., thinner, kerosene and acetone) to wipe the appliance exterior, or affix labels on the exterior. Doing so may damage the product surface.
- Care should be exercised to prevent flowing of water into the product.

NOTE

- If dust on the front and rear covers cannot be removed, disassemble the covers and clean them with water. After cleaning, dry the covers thoroughly in the shade.

Cleaning the Particles Sensor

PM1.0 sensor detects fine particles as well as coarse particles. Therefore, you need to clean its lens regularly.

- 1 Separate the rear cover of the product.
- 2 Open the sensor cover.

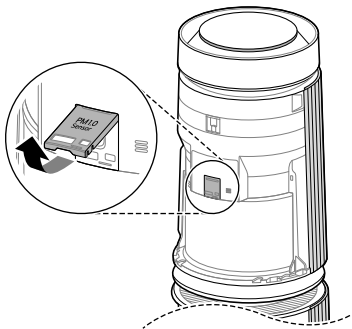

- 3 Clean the lens with a cotton swab soaked with water and clean it again with a dry cotton swab.

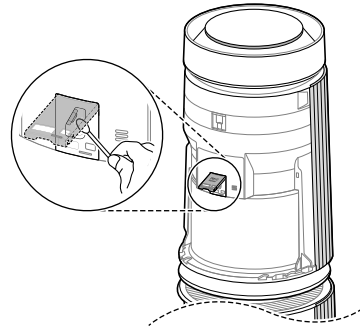

NOTE

- Do not wipe the sensor with any substances other than water. It may cause a appliance to malfunction.

Cleaning the Filters

- 1 Separate the cover of the product.
- 2 Remove particles off of the pre-filter with a vacuum cleaner or a soft brush.
 - If contamination cannot be eliminated after cleaning, replace the pre-filter.

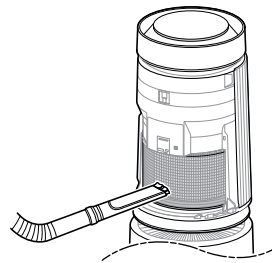

- 3 Separate the pre-filter from the total filter.
 - How to separate the pre-filter: Check the Velcro of the pre-filter and carefully remove

the pre-filter in order to avoid it being damaged.

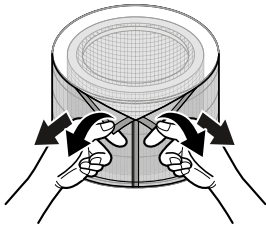

4 When you assemble the pre-filter, follow the reverse order of the separation procedure.

5 Regenerating harmful gases photocatalyst care.

- If you want to regenerate the functions of the photocatalyst deodorizing filter, expose it to direct sunlight.
- The filter is regenerated by the light.
- At night, expose the filter for about 3 hours using a light to regenerate it.
- Recommended regeneration period: About 3 hours every 2 months.

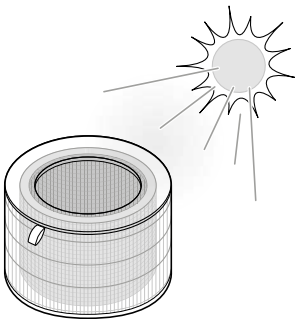

⚠ CAUTION

- Do not clean the filter with water. The service life of the filter may be reduced.
- Be careful not to damage the pre-filter when using a vacuum cleaner.
- Take caution because there is a risk of tearing or loss when separating or assembling the pre-filter.

NOTE



- In case of the dual model, clean the bottom filter in the same way.

Replacing the Filter

- 1** Separate the cover from the product and replace the filter.
 - To avoid polluting the surroundings when replacing the filter, place a newspaper on the floor before you remove the filter.
- 2** Once you have replaced the filter, disable the filter replacement alert.

Disabling the Filter Replacement Alert

Press and hold the **Speed** and **Allergy Care** buttons simultaneously for 3 seconds or more.

- The  (Single Model Filter Replacement Alert) or  (Dual Model Top Filter Replacement Notification) on the status panel is disabled and the replacement alarm is reset.

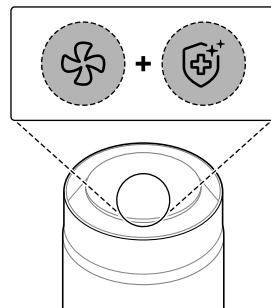

Disabling the Filter Replacement Alert (Only for relevant models)

Press and hold the **Allergy Care** and **Sleep Timer** buttons simultaneously for 3 seconds or more.

- The  (Bottom Filter Replacement Alert) on the status panel is disabled and the replacement alarm is reset.

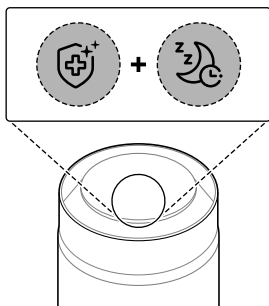

CAUTION

- Do not store the appliance at a humid place or at a place exposed to the direct sunlight. Otherwise the appliance may be deformed, malfunction or generate odor.
-

NOTE

- The filter replacement alert is disabled automatically if 24 hours have passed since it was displayed or if the product is disconnected from the power source.
-

Storage

If the appliance is not used for a long period of time, store it at a shaded and dry place.

- 1** Operate the product for one hour or more on a fine day.
 - This removes moisture and prevents molds from building-up inside the product.
- 2** Turn off the power and unplug it from the electrical outlet.
 - Wind the power cord around the bottom of the appliance.
- 3** Package the appliance to prevent the dust or foreign substance from entering the appliance. Store the packaged appliance at a shaded place.

TROUBLESHOOTING

Before Calling for Service

Please check the following before calling for service. If the problem persists, contact your local service center.

Operation

Symptoms	Possible Cause & Solution
The appliance does not operate.	<p>The power plug in unplugged from the outlet.</p> <ul style="list-style-type: none"> Plug it into the outlet properly.
There is odor, but the air quality light doesn't change.	<p>Is the air quality light red or orange?</p> <ul style="list-style-type: none"> The color of the overall air quality light is determined by the worst level sensed, whether that is a PM concentration or odor. The PM concentration level may be worse than the odor level. The odor (gas) sensor is designed to detect harmful gases. Strong food odors may not register as harmful, but the Deodorization filter will minimize them.
The air quality light stays red.	<p>Move the appliance to a different room and see if the color changes.</p> <ul style="list-style-type: none"> If the odor level is beyond the capacity of the product to dispel, the light may not change. Clean the sensor area. Remove the power plug from the outlet and reconnect it one minute later.
	<p>A substance was sprayed near the product.</p> <ul style="list-style-type: none"> Do not use sprays near the product.
The buttons on the control panel do not work.	<p>The  (Lock) is turned on on the status panel.</p> <ul style="list-style-type: none"> Press and hold the Sleep Timer button for 3 seconds to disable the lock function.
The PM concentration doesn't change.	<p>There is a foreign substance on the sensor.</p> <ul style="list-style-type: none"> Clean the PM1.0 sensor.
	<p>The product is used in an enclosed space.</p> <ul style="list-style-type: none"> In an enclosed space without frequent air exchange, the air quality may stay the same.
The PM concentration stays high.	<p>The product is located in an area with frequent airflow from the outside.</p> <ul style="list-style-type: none"> In an environment where outside air is supplied continuously, the PM concentration may remain high.

Symptoms	Possible Cause & Solution
The color of the overall air quality light does not match the PM concentration value.	<p>The overall air quality light may be reflecting the odor level.</p> <ul style="list-style-type: none"> The overall air quality is based on both the PM concentration and the odor level, and its color is determined by which is worse. If the PM concentration is low and the odor level is high, the overall air quality light will reflect the odor level.
The clean booster is not working.	<p>The Booster mode is not selected.</p> <ul style="list-style-type: none"> The booster fan speed and booster fan rotation functions work only in the Booster mode.
The PM concentration levels are different between the appliance and the LG ThinQ application.	<p>Make sure you are comparing the levels for the same size particulates.</p> <ul style="list-style-type: none"> Make sure that the levels of the PM1.0/PM2.5/PM10 are displayed consistently between the LG ThinQ application and your appliance. The LG ThinQ application may not update the sensor results as quickly as the appliance display.

Performance

Symptoms	Possible Cause & Solution
The indoor air is not purified well enough.	<p>The indoor air is very dirty.</p> <ul style="list-style-type: none"> Ventilate the indoor air before you use the product.
	<p>The pre-filter is clogged with dust.</p> <ul style="list-style-type: none"> Clean the pre-filter properly.
	<p>The filter is clogged with dust.</p> <ul style="list-style-type: none"> Replace the whole filter.
	<p>The location is too large for the capability of the air purifier.</p> <ul style="list-style-type: none"> Use a product that fits the size of the room. Place the appliance away from windows, doors, and other areas with frequent influx of outdoor air.
	<p>The air inlet or outlet is blocked.</p> <ul style="list-style-type: none"> Remove the obstacle.
	<p>The appliance is located in a corner or an area where air circulation is blocked.</p> <ul style="list-style-type: none"> Move the appliance and install it again.

Noise

Symptoms	Possible Cause & Solution
Fan is noisy even on the lowest speed.	The pre-filter is clogged with dust. <ul style="list-style-type: none"> Clean the pre-filter properly.
	The filter is clogged with dust. <ul style="list-style-type: none"> Replace the whole filter.
The appliance makes a sudden loud noise while operating.	The operating mode is set to Smart mode or the fan speed is on Auto. <ul style="list-style-type: none"> It may make a sudden noise as it automatically adjusts the air flow depending on indoor air quality.
A noise is generated when I start or stop the clean booster.	The clean booster is looking for the correct location. <ul style="list-style-type: none"> -

Odor

Symptoms	Possible Cause & Solution
A strange odor comes out from the air outlet as well as the filter.	Appliance is new. <ul style="list-style-type: none"> The odor of activated charcoal is not harmful. This is similar to the odor you may experience in a brand new car. The odor should dissipate after 1-2 weeks of use.
	The appliance is located in an area with a lot of smoke or odors. <ul style="list-style-type: none"> In areas with a lot of smoke or odors, the lifespan of the filters may be greatly decreased. For best results, ventilate the room first, then use the appliance.
	The odor is coming from the filter. <ul style="list-style-type: none"> Replace the filter. The filter replacement frequency may differ depending on the usage environment.
	The appliance is located in an area with a lot of strong odors. <ul style="list-style-type: none"> If the appliance is used near where you cook or broil fish or meat, the lifespan of the filters will be greatly decreased. For best results, ventilate the area first by opening a window or using a vent hood. Use the appliance only to minimize odors left after ventilating the area.

LG ThinQ

Symptoms	Possible Cause & Solution
<p>The product and the smartphone cannot be connected through Wi-Fi.</p>	<p>Is the Wi-Fi password used to connect to the smartphone correct?</p> <ul style="list-style-type: none"> • Press the Settings button on your smartphone, and then find your Wi-Fi in the network list. Press and hold the button to select [Clear Network], and then proceed with product registration again from the beginning.
	<p>Is your smartphone using mobile data rather than Wi-Fi?</p> <ul style="list-style-type: none"> • In the smartphone's settings, turn off Mobile Data, turn on Wi-Fi, and then register the product.
	<p>Does the name (ID) of the wireless router contain special characters?</p> <ul style="list-style-type: none"> • Set the name (ID) of the wireless router as a combination of numbers and English letters. Wi-Fi connection may be difficult if you enter special characters.
	<p>Is the frequency of the wireless router not 2.4 GHz?</p> <ul style="list-style-type: none"> • When connecting the product via Wi-Fi, only a 2.4 GHz network can be used. Set the wireless router to 2.4 GHz and then connect. To check the frequency of your wireless router, contact your Internet carrier or router manufacturer.
	<p>Are the product and the wireless router too far apart?</p> <ul style="list-style-type: none"> • If the distance between the product and the wireless router is too great, the wireless signal may be weak, and the connection may not be smooth. Move the wireless router closer to the product.

APPENDIX

Information

APPLIANCE SPECIFICATIONS

- Appearance and specifications may vary without notice to improve the quality of the appliance.

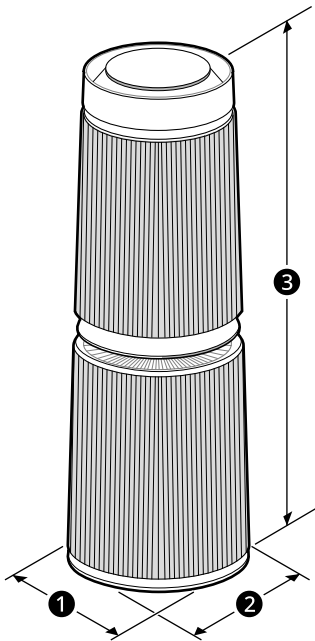

Dual Model

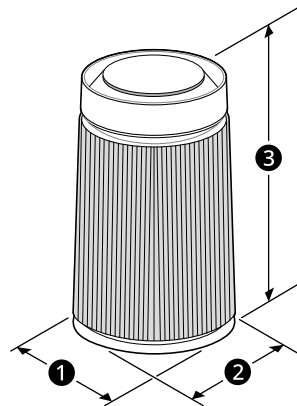

Single Model

Name	AS10GD Series, AS65GD Series
Power	AC 220 - 240 V~ 50 Hz
Dual Model Exterior Dimensions (1 x 2 x 3)	When Clean Booster is stopped: 377mm x 377mm x 1,100mm
	When Clean Booster is operating: 377mm x 377mm x 1,391mm
Single Model Exterior Dimensions (1 x 2 x 3)	When Clean Booster is stopped: 347mm x 347mm x 612mm
	When Clean Booster is operating: 347mm x 347mm x 803mm

Warranty

Warranty Information

- Warranty period of Product :
 - 1 year from the date of original retail purchase.
 - 10 Years on Inverter Motor only
(except for Wearable Air Purifier, Puricare Mini, 360° Air Purifier Hit)

LG Customer Information Centre

- For any Suggestion, Opinion & Complaints, Within UAE please Call 800 54 (LG), or please contact to our local dealer or log into www.lg.com.
- For any Suggestion, Opinion & Complaints, Out side UAE please contact to our local dealer or log into www.lg.com.

Importers

Country	Trade Name	Address
UAE	LG Electronics Gulf FZE	GF-Jebel Ali Main Warehouse, Jebel Ali Free Zone, P.O. Box: 61445 Dubai, UAE
	Al Yousuf Electronics	Al Yousuf Electronics AL YOUSUF ELECTRONICS LLC P.O. BOX NO 25 DUBAI, UAE TEL: +971 4 295 7300 FAX: +971 4 295 7988
Qatar	Video Home & Electronic Centre W.L.L	Video Home & Electronic Centre W.L.L, P.O. Box 4668, Doha, Qatar TEL: +974 4 401 1777 FAX: +974 4 476 1715
Oman	Oman Gulf Enterprises LLC	P.O. Box 421, PC 118, Muscat, Sultanate of Oman TEL: +968 2 200 6300
Iraq	Khoshnaw Company for Commercial Investment	Koya Road, Erbil, Iraq
Jordan	New Vision for Electronics & Electrical Appliances	Mecca street, Building #14, Faouri Complex, 5th Floor P.O. Box 930254 Amman, 11193 Jordan TEL: +962 6 500 4400

