



website <http://www.lgservice.com>  
e-mail <http://www.lgservice.com/techsup.html>

LG

# LG

## Air Conditioner

### *INSTALLATION MANUAL*

ENGLISH

ITALIANO

ESPAÑOL

FRANÇAIS

DEUTSCH

#### IMPORTANT

- Please read this installation manual completely before installing the product.
- Installation work must be performed in accordance with the national wiring standards by authorized personnel only.
- Please retain this installation manual for future reference after reading it thoroughly.

# TABLE OF CONTENTS

<b><i>Installation Requirements</i></b>	<b><i>Required Parts</i></b>	<b><i>Required Tools</i></b>
<b>Safety Precautions .....3</b>		
<b>Installation of Indoor, Outdoor unit .....6</b>	<ul style="list-style-type: none"> <li>• Connecting cable</li> </ul>	<ul style="list-style-type: none"> <li>• Level</li> </ul>
<b>The indoor unit installation .....9</b>	<ul style="list-style-type: none"> <li>• Four Type "A" Screw</li> <li>• Hanging Bolt (W 3/8 or M10 length 650mm)</li> </ul>	<ul style="list-style-type: none"> <li>• Screw driver</li> <li>• Electric drill</li> <li>• Hole core drill (ø70mm)</li> </ul>
<b>Remote controller installation .....23</b>		
<b>Wiring connection ....24</b>		
<b>Connecting Pipes to the Indoor Unit .....26</b>	<ul style="list-style-type: none"> <li>• Pipes: Gas side</li> <li style="padding-left: 20px;">Liquid side</li> </ul>	<ul style="list-style-type: none"> <li>• Flaring Tools set</li> <li>• Torque Wrenches</li> </ul>
<b>Installation to decorative panel .....28</b>	<ul style="list-style-type: none"> <li>• Insulated drain hose</li> <li>• Additional Drain hose</li> </ul>	<ul style="list-style-type: none"> <li>• Hexagonal Wrench (4mm, 5mm)</li> <li>• Gas-leak detector</li> </ul>
<b>Indoor unit drain piping .....29</b>	<ul style="list-style-type: none"> <li>Inner Dia</li> <li>Cassette type .....32mm</li> <li>Duct type .....25mm</li> <li>Convertible type .....25mm</li> </ul>	
<b>Test running .....32</b>		<ul style="list-style-type: none"> <li>• Owner's Manual</li> </ul>
<b>Optional operation ....34</b>		<ul style="list-style-type: none"> <li>• Thermometer</li> </ul>

# Safety Precautions



To prevent injury to the user or other people and property damage, the following instructions must be followed.

- Incorrect operation due to ignoring instruction will cause harm or damage. The seriousness is classified by the following indications.

**⚠ WARNING** This symbol indicates the possibility of death or serious injury.

**⚠ CAUTION** This symbol indicates the possibility of injury or damage.

- Meanings of symbols used in this manual are as shown below.

	<b>Be sure not to do.</b>
	<b>Be sure to follow the instruction.</b>

## ⚠ WARNING

### ■ Installation

**Do not use a defective or underrated circuit breaker. Use this appliance on a dedicated circuit.**

- There is risk of fire or electric shock.

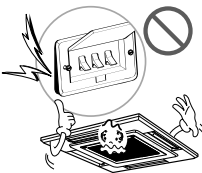

**For electrical work, contact the dealer, seller, a qualified electrician, or an Authorized Service Center.**

- Do not disassemble or repair the product. There is risk of fire or electric shock.



**Always ground the product.**

- There is risk of fire or electric shock.



**Install the panel and the cover of control box securely.**

- There is risk of fire or electric shock.



**Always install a dedicated circuit and breaker.**

- Improper wiring or installation may cause fire or electric shock.



**Use the correctly rated breaker or fuse.**

- There is risk of fire or electric shock.

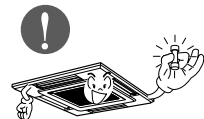

**Do not modify or extend the power cable.**

- There is risk of fire or electric shock.

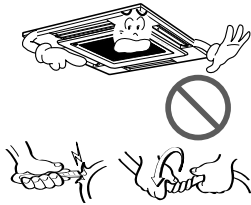

**For installation, always contact the dealer or an Authorized Service Center.**

- There is risk of fire, electric shock, explosion, or injury.

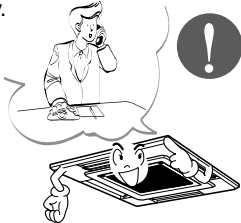

**Be sure the installation area does not deteriorate with age.**

- If the base collapses, the air conditioner could fall with it, causing property damage, product failure, and personal injury.



**Be cautious when unpacking and installing the product.**

- Sharp edges could cause injury. Be especially careful of the case edges and the fins on the condenser and evaporator.



**Do not install the product on a defective installation stand.**

- It may cause injury, accident, or damage to the product.



**Do not let the air conditioner run for a long time when the humidity is very high and a door or a window is left open.**

- Moisture may condense and wet or damage furniture.



**■ Operation**

**Do not store or use flammable gas or combustibles near the product.**

- There is risk of fire or failure of product.



**It is recommended to install the indoor unit into the one big space, rather than into the some small spaces.**

# CAUTION

## ■ Installation

Always check for gas (refrigerant) leakage after installation or repair of product.

- Low refrigerant levels may cause failure of product.

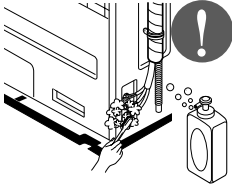

Install the drain hose to ensure that water is drained away properly.

- A bad connection may cause water leakage.

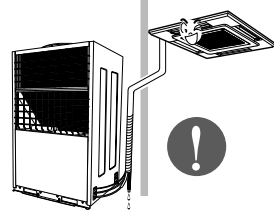

Keep level even when installing the product.

- To avoid vibration or water leakage.

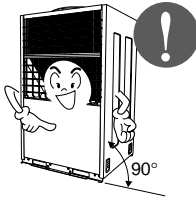

Do not install the product where the noise or hot air from the outdoor unit could damage the neighborhoods.

- It may cause a problem for your neighbors.



Use two or more people to lift and transport the product.

- Avoid personal injury.



Do not install the product where it will be exposed to sea wind (salt spray) directly.

- It may cause corrosion on the product. Corrosion, particularly on the condenser and evaporator fins, could cause product malfunction or inefficient operation.

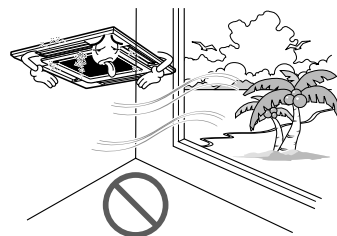

# Installation of Indoor, Outdoor Unit

## Selection of the best location

### 1. Indoor unit

#### Cassette type

- There should not be any heat source or steam near the unit.
- There should not be any obstacles to prevent the air circulation.
- A place where air circulation in the room will be good.
- A place where drainage can be easily obtained.
- A place where noise prevention is taken into consideration.
- Do not install the unit near the door way.
- Ensure the spaces indicated by arrows from the wall, ceiling, or other obstacles.
- The indoor unit must keep the maintenance space.

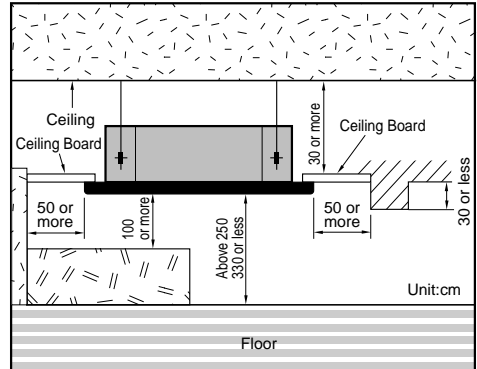

#### Duct type

- The place shall easily bear a load exceeding four times the indoor unit's weight.
- The place shall be able to inspect the unit as the figure.
- The place where the unit shall be leveled.
- The place shall allow easy water drainage. (Suitable dimension "H" is necessary to get a slope to drain as figure.)
- The place shall easily connect with the outdoor unit.
- The place where the unit is not affected by an electrical noise.
- The place where air circulation in the room will be good.
- There should not be any heat source or steam near the unit

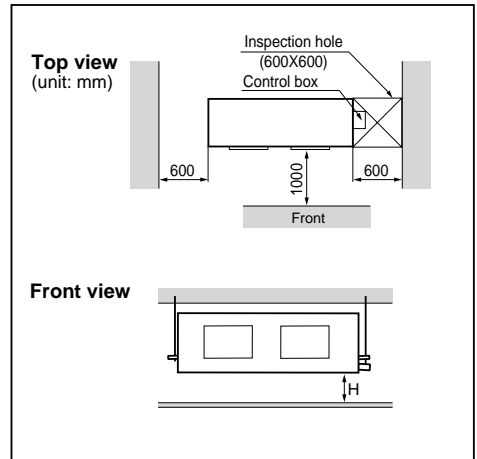

### Convertible type

- There should not be any heat source or steam near the unit.
- There should not be any obstacles to prevent the air circulation.
- A place where air circulation in the room will be good.
- A place where drainage can be easily obtained.
- A place where noise prevention is taken into consideration.
- Do not install the unit near the door way.
- Ensure the spaces indicated by arrows from the wall, ceiling, or other obstacles.

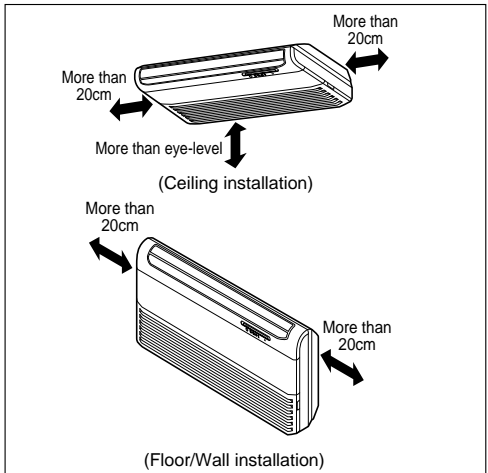

### 2. Outdoor unit

1. If an awning is built over the unit to prevent direct sunlight or rain exposure, make sure that heat radiation from the condenser is not restricted.
2. Ensure that the spaces indicated by arrows around front, back and side of the unit.
3. Do not place animals and plants in the path of the warm air.
4. Take the air conditioner weight into account and select a place where noise and vibration are minimum.
5. Select a place so that the warm air and noise from the air conditioner do not disturb neighbors.

### Rooftop Installations:

If the outdoor unit is installed on a roof structure, be sure to level the unit. Ensure the roof structure and anchoring method are adequate for the unit location. Consult local codes regarding rooftop mounting.

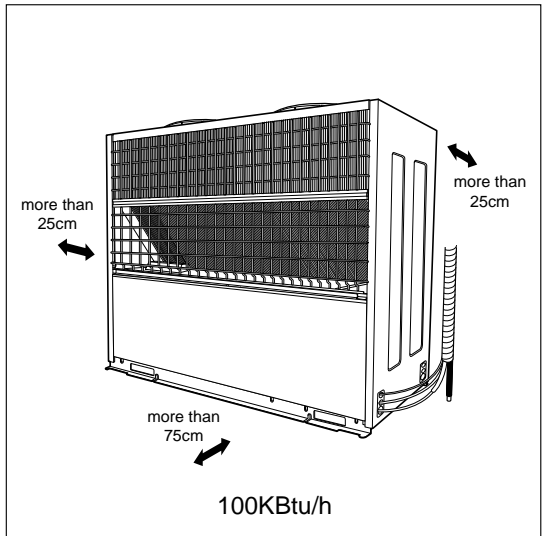
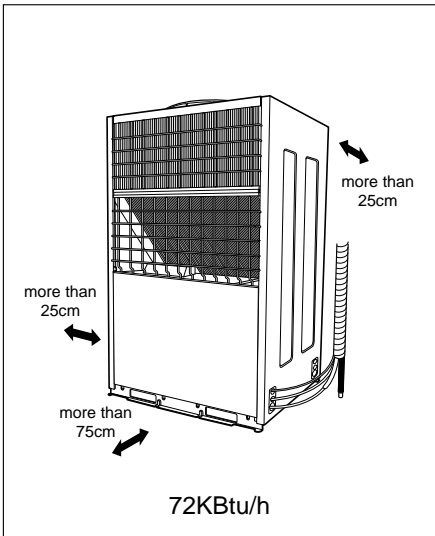

### 3. Piping length and the elevation

Install the branch pipe so that pipe length and difference between high and low will not exceed below SPEC.

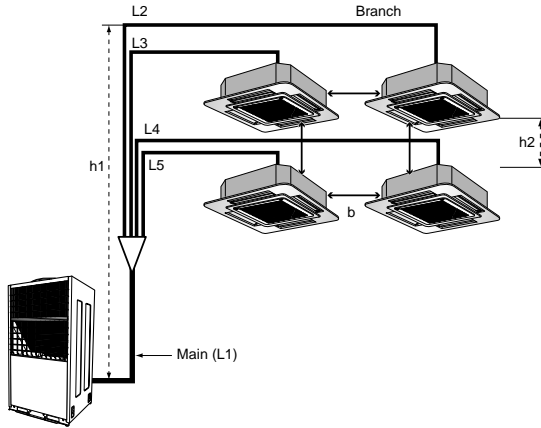

Pipe Length(m)	Spec.
Total(Main+Branch)	110
Main Pipe(L1)	50
Branch Pipe-----Total	60
Each	15
In out (h1)	30
In-In (h2)	1
L1+L2/L3/L4/L5	65
Indoor-Indoor_(b)	10

- When installing the branch pipe, direction and angle of installation is not limited.
- Take care so that burrs and foreign material may not enter into the cutting surface when connecting.
- Connect a gas pipe of Ø25.4 by welding the elbow in the outdoor unit and connect remaining those by cutting or direct insertion to the diameter of pipe.
- Don't use the liquid pipe by too bending or twisting.

### 4. Refrigerant Additional Charging Method

For additional charging method, see below table.

Duo(2 indoor unit)	Refrigerant=(L1-30) x 0.05 + (L2+L3-20) x A	
Trio(3 indoor unit)	Refrigerant=(L1-30) x 0.05 + (L2+L3+L4-20) x A	
Quartet(4 indoor unit)	Refrigerant=(L1-30) x 0.05 + (L2+L3+L4+L5-20) x A	
	Branch pipe	A
Liquid side	Ø 6.35	0.03
	Ø 9.52	0.05

<Ref. Addition charging method>

※ (L1=Main Pipe, L2~L5 : Branch Pipe)



#### CAUTION:

- Rated performance for refrigerant line length of:7.5m
- Capacity is based on standard length and maximum allowance length is on the basis of reliability.
- Improper refrigerant charge may result in abnormal cycle.
- Oil trap should be installed every 10 meters.

# The indoor unit installation

## 1. Cassette type

- The dimensions of the paper model for installing are the same as those of the ceiling opening dimensions.

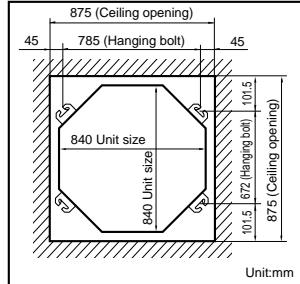
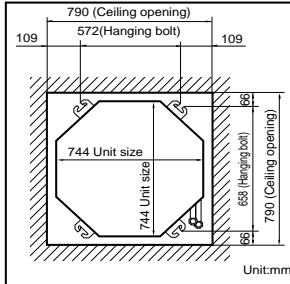
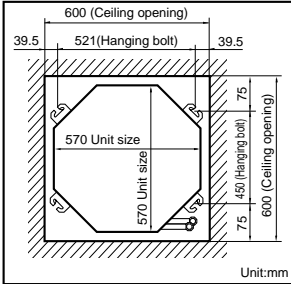

- Select and mark the position for fixing bolts and piping hole.
- Decide the position for fixing bolts slightly tilted to the drain direction after considering the direction of drain hose.
- Drill the hole for anchor bolt on the wall.



### CAUTION:

- This air-conditioner uses a drain pump.
- Horizontally install the unit using a level gauge.
- During the installation, care should be taken not to damage electric wires.

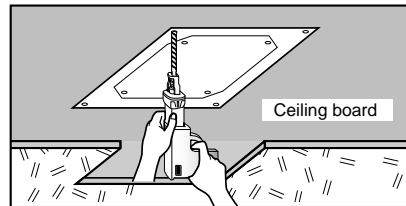
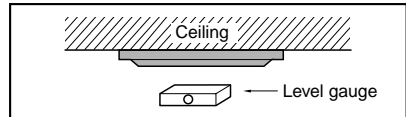

### NOTICE

- Thoroughly study the following installation locations:
  - In such places as restaurants and kitchens, considerable amount of oil steam and flour adhere to the turbo fan, the fin of the heat exchanger and the drain pump, resulting in heat exchange reduction, spraying, dispersing of water drops, drain pump malfunction, etc. In these cases, take the following actions:
    - Make sure that the ventilation fan for smoke-collecting hood on a cooking table has sufficient capacity so that it draws oily steam which should not flow into the suction of the air conditioner.
    - Make enough distance from a cooking room to install the air conditioner in such a place where it may not suck in oily steam.

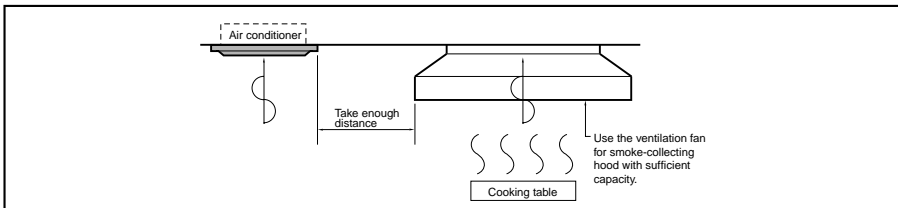

- Avoid installing air conditioner in such circumstances where cutting oil mist or iron powder is in suspension in factories, etc.
- Avoid places where inflammable gas is generated, flows in, is stored or vented.
- Avoid places where sulfurous acid gas or corrosive gas is generated.
- Avoid places near high frequency generators.

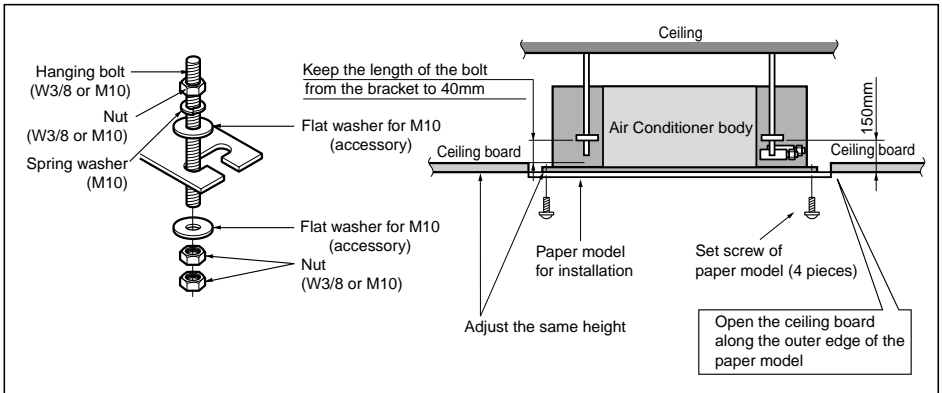

- The following parts is option.
  - ① Hanging Bolt - W 3/8 or M10
  - ② Nut - W 3/8 or M10
  - ③ Spring Washer - M10
  - ④ Plate Washer - M10

- Drill the piping hole on the wall slightly tilted to the outdoor side using a  $\varnothing 70$  hole-core drill.



**CAUTION:** Tighten the nut and bolt to prevent unit falling.

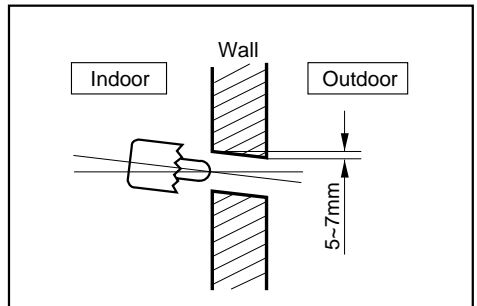

## 2. Duct type

### CASE 1

#### POSITION OF SUSPENSION BOLT

- Apply a joint-canvas between the unit and duct to absorb unnecessary vibration.
- Apply a filter Accessory at air return hole.

(Unit:mm)

Dimension Capacity	A	B	C	D	E	F	(G)	H	I
18K/24K BTU/h	932	880	355	45.5	450	30	87	750	163
30K/36K BTU/h	1232	1182	355	45.5	450	30	87	830	186
48K/60K BTU/h	1292	1230	477	56	590	30	120	1006	294

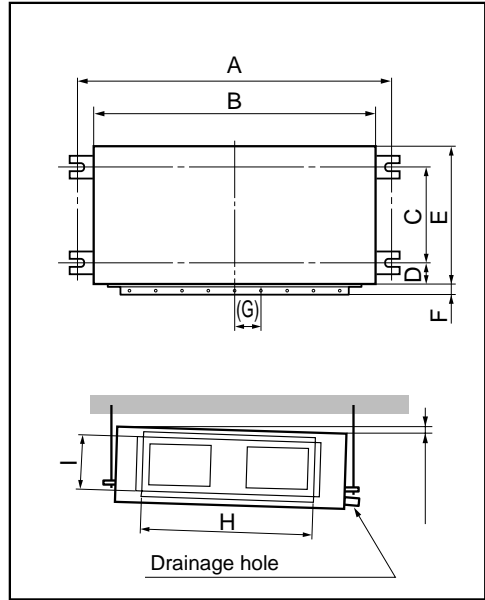

### CASE 2

- Install the unit leaning to a drainage hole side as a figure for easy water drainage.

#### POSITION OF CONSOLE BOLT

- A place where the unit will be leveled and that can support the weight of the unit.
- A place where the unit can withstand its vibration.
- A place where service can be easily performed.

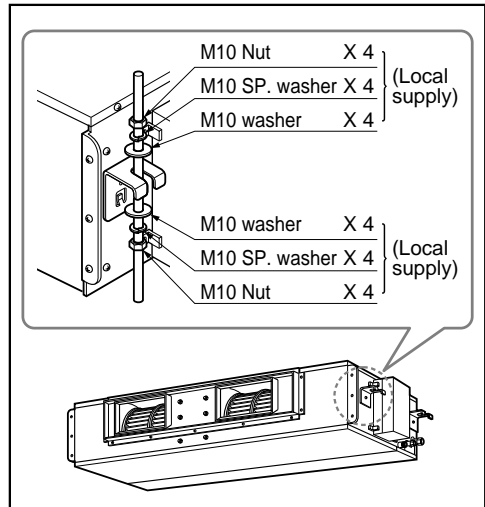

- Select and mark the position for fixing bolts.
- Drill the hole for set anchor on the face of ceiling.

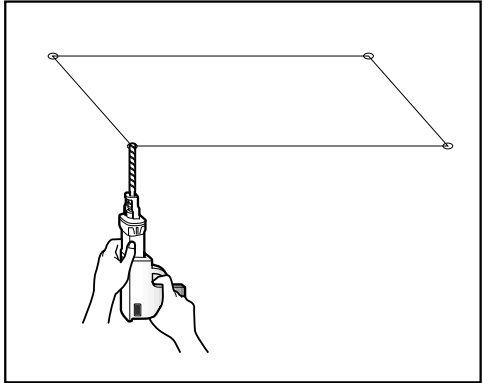

- Insert the set anchor and washer onto the suspension bolts for locking the suspension bolts on the ceiling.
- Mount the suspension bolts to the set anchor firmly.
- Secure the installation plates onto the suspension bolts (adjust level roughly) using nuts, washers and spring washers.



**CAUTION:** Tighten the nut and bolt top revent unit falling.

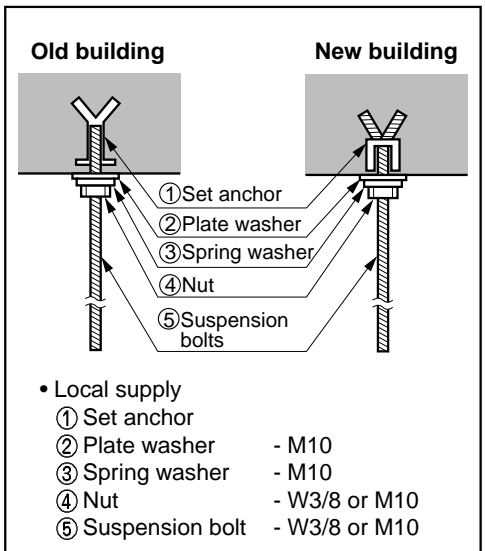

**CAUTION**

1. **Install declination** of the indoor unit is very **important for the drain** of the duct type air conditioner.
2. Minimum thickness of the insulation for the connecting pipe shall be 5mm.

**Front of view**

- The unit must be horizontal or declined to the drain hose connected when finished installation.

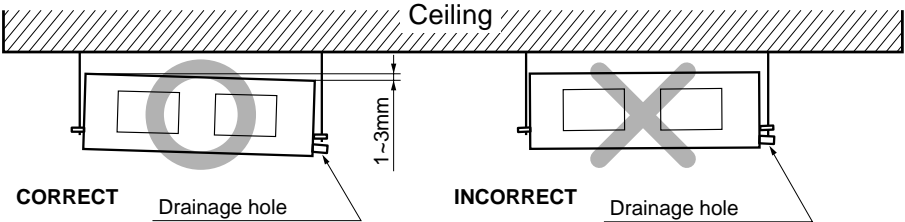

**CAUTION FOR GRADIENT OF UNIT AND DRAIN PIPING**

Lay the drain hose with a downward inclination so water will drain out.

- Always lay the drain with downward inclination (1/50 to 1/100). Prevent any upward flow or reverse flow in any part.
- 5mm or thicker formed thermal insulator shall always be provided for the drain pipe.

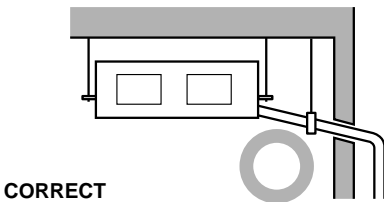
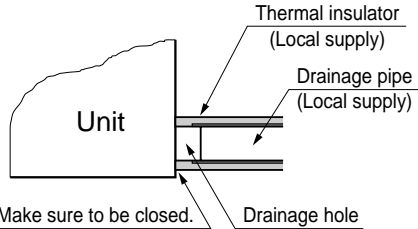

- Upward routing not allowed

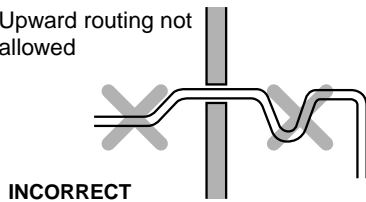

- Install the P-Trap (or U-Trap) to prevent a water leakage caused by the blocking of intake air filter.

**Applied U-Trap Dimension**

- A 70mm
- B 2C
- C 2 x SP
- SP = External Pressure (mmAq)
- Ex) External Pressure = 10mmAq
- A 70mm
- B 40mm
- C 20mm

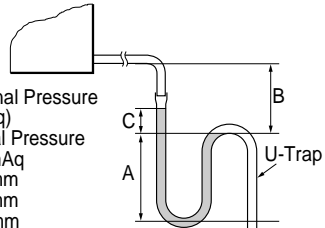

### 3. Convertible type

#### ■ Before Installing, prepare Installation Plates

- 'Installation Plates' are attached at the bottom of indoor unit.  
Detach them by removing each 3 screws at both sides.
- Detach 'Side Plate (R,L)' by removing each 2 screws on both sides.
- Pull the upper right and left side of 'Inlet Grille' to the front, and it will stop at slightly tilted position.
- Unhook the 'Inlet hanger' from the 'Hanger screw' on the both left and right side.
- Detach the 'Inlet Grille' from the Indoor Unit.

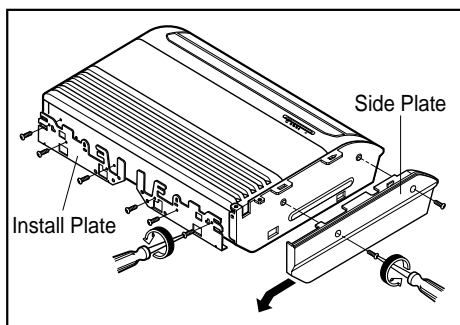

#### Installation on the ceiling

- Measure and mark the position for the Suspension bolts and the piping hole.
- Drill the hole for anchor nut on the ceiling.

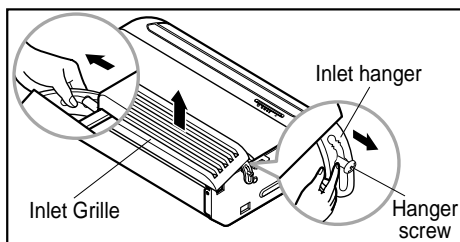

- ※ Before secure the Installation Plates, select the bent direction of the Installation Plate to the inside or the outside according to the installation circumstances.

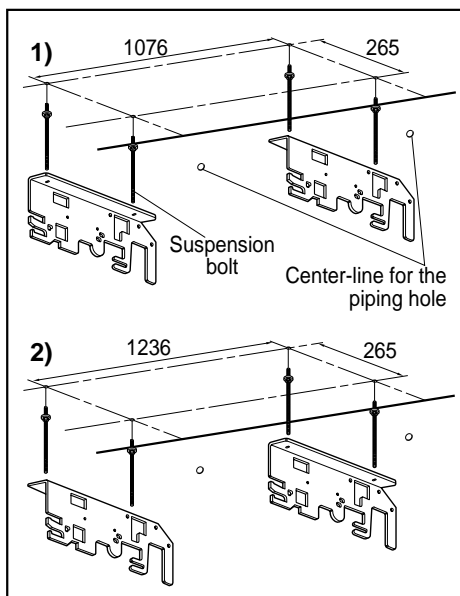

- Drill the piping hole on the wall slightly tilted to the outdoor side using a  $\phi 70$  hole-core drill.

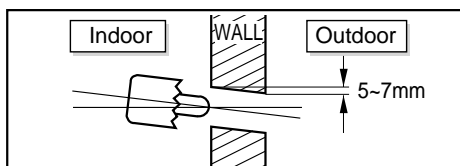

- Insert the nuts and washer onto the suspension bolts for locking the suspension bolts on the ceiling.
- Mount the suspension bolts to the anchor-nuts firmly.
- Secure the Installation plates onto the Suspension bolts (adjust level roughly,) using nuts, washers and spring washers.

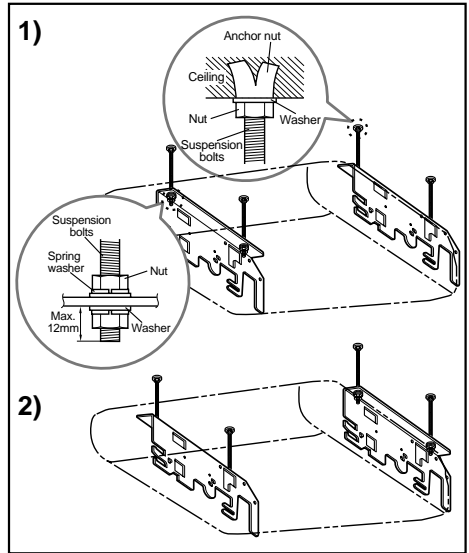

- Engage 2 hooks on the both left and right side of the unit to the lower slot of Installation Plates.
- Adjust a level with a level gauge on the direction of left-right, back-forth by adjusting suspension bolts.
- Move the hooks on the unit to the upper slot of Installation Plates. Then the unit will be declined to the bottomside so as to drain well.

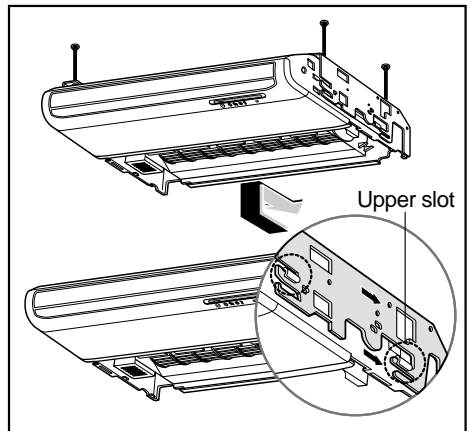
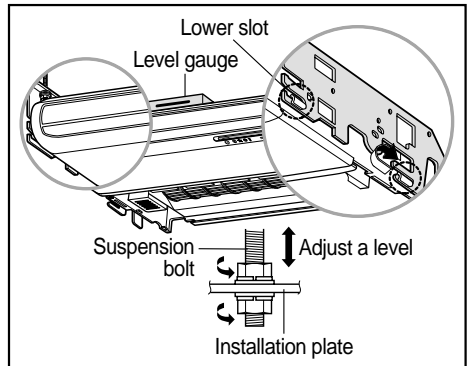

**CAUTION**

1. **Install declination** of the indoor unit is very **important for the drain** of the convertible type air conditioner.
2. Minimum thickness of the insulation for the connecting pipe shall be 7mm.
3. If the Installation Plates are fixed to horizontal line, the indoor unit after installing will be declined to the bottomside.

**Front of view**

- The unit must be horizontal or declined to the drain hose connected when finished installation.

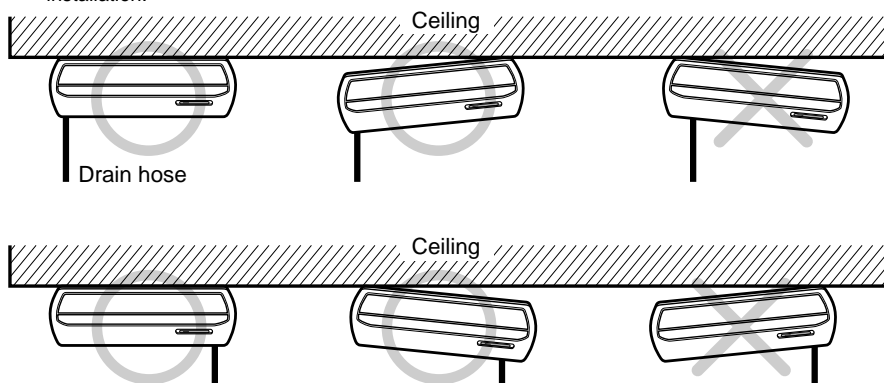

**Side of view**

- The unit must be declined to the bottomside of the unit when finished installation.

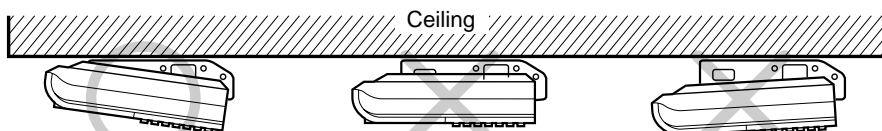

- Secure the unit to the Installation Plates with four M8 bolts and washers.

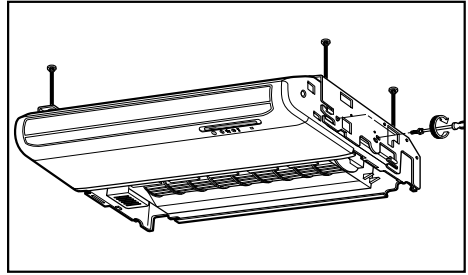

- Before working, refer to "Connecting pipe to Indoor Unit" on page 21.

- Hook up the Inlet Grille Hook to the cabinet.
- Hang the Inlet Hanger to the screw.

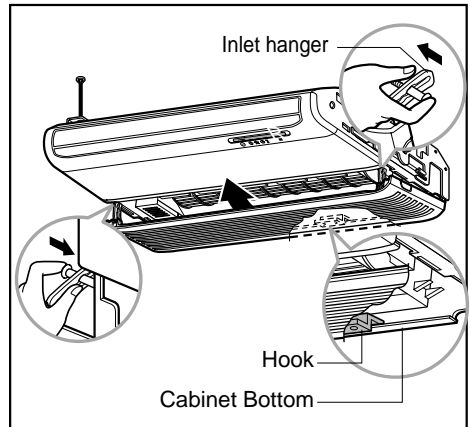

- Fit the projection hooks of the side plates to the 'Side Panel' and the 'Front Panel' by lifting it.
- Fasten the screws.

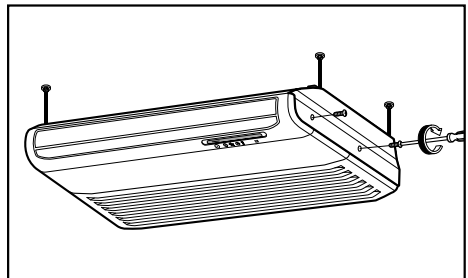
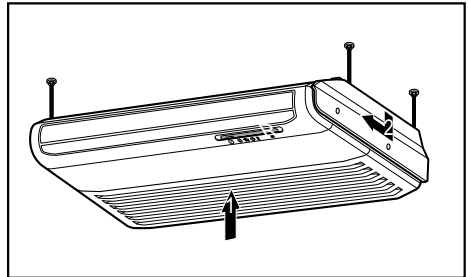

### Installation on the Wall

- Select and mark the position for fixing bolts and piping hole.  
Decide the position for fixing bolts slightly tilted to the drain direction after considering the direction of drain hose.
- Drill the hole for anchor nut on the wall.

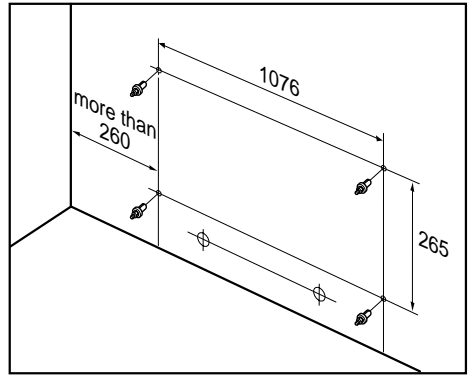

- Drill the piping hole on the wall slightly tilted to the outdoor side using a  $\phi 70$  hole-core drill.

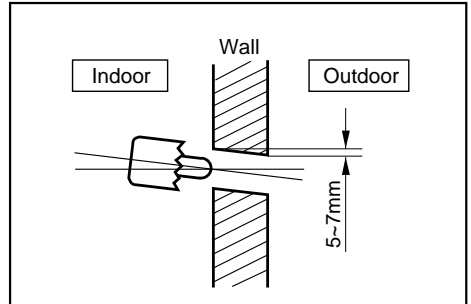

- Secure the 'Install Plate' onto the wall with four anchor bolts, washers and spring washers.

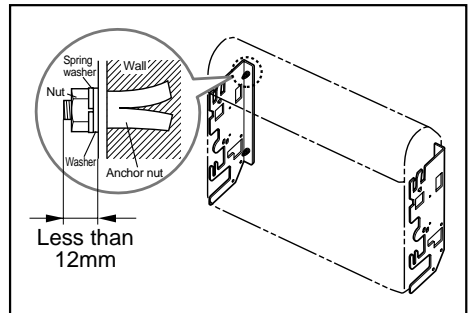

- ※ Before secure the Install Plates, select the bent direction of the 'Install Plate' to the inside or outside according to the installation circumstances.

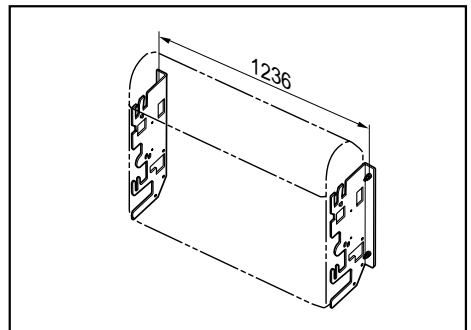

Install the Indoor unit onto Installation Plate.

- Insert 2 hooks on the both left and right side of the unit to the inner slot (wall side) of the Installation Plate.
- Secure the unit to the Installation Plate with four M8 bolts and washers.

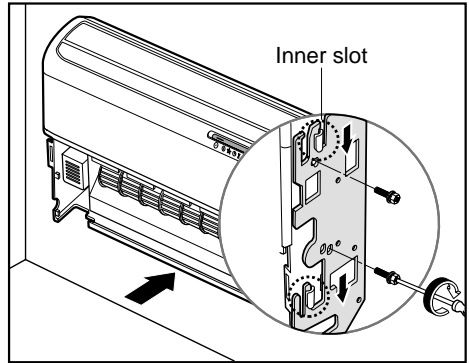

- Before working, refer to "Connecting pipe and cable to Indoor Unit" on page 21.

- Hook up the Inlet Grille Hook to the cabinet.
- Hang the Inlet Hanger to the screw.

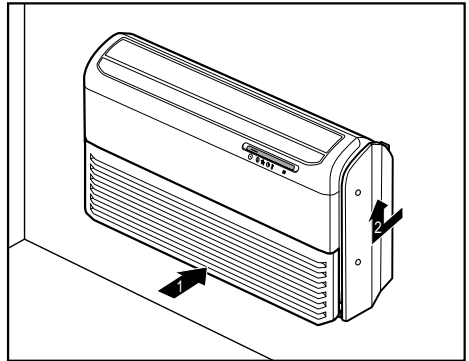

- Fit the projection hooks of the side plates to the 'Side Panel' and the 'Front Panel' by lifting it.
- Fasten the screws.

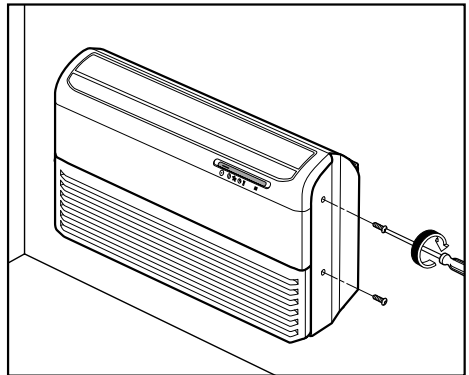

## Installation on the floor

Installation of Mount Bracket.

- Select and mark the position for Mount Brackets and the piping hole.
- Drill the hole for the anchor nut on the wall.
- Drill the piping hole using a  $\varnothing 70$  hole-core drill.
- Secure the Mount Brackets on the wall with four M4 screws.

Install the indoor unit onto the Mount Brackets.

- Engage the slot at the back of the unit with Mount Bracket.

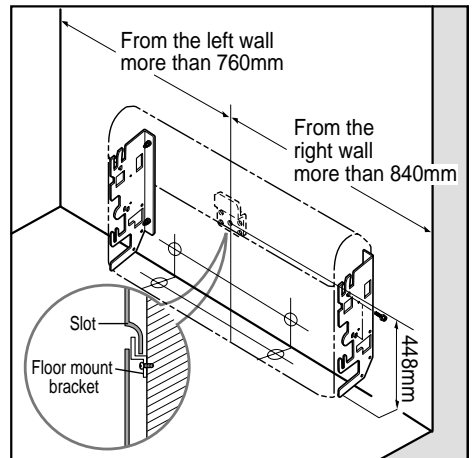

- Drill the piping hole with 70mm dia, hole core drill.
- Piping hole should be slightly slant to the outdoor side.

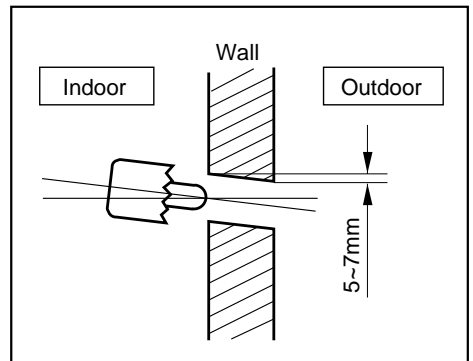

### After Installing, reassemble detached parts.

- Hang the 'Inlet Grille' and hook the 'Inlet Hanger' to the Hanger Screw.
- Assemble the 'Side Plates(R,L)' with 2 screws on both left and right side.

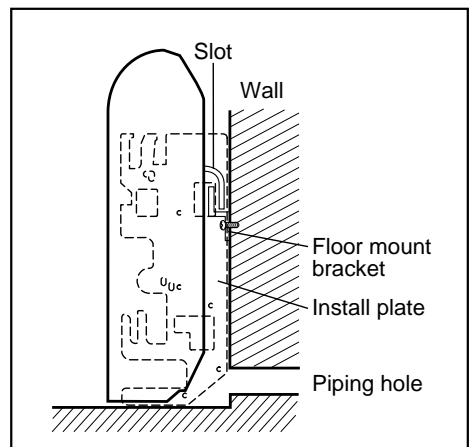

## Installation on the ceiling (Connecting the pipes to the indoor unit)

The pipe can be connected to right side, bottom or back of the unit.

### 1. For the Right Side Piping

- After bending an end of the connecting tube, align the center of the pipings and sufficiently tighten the flare nut with fingers.
- Finally, tighten the flare nut with torque wrench until the wrench clicks.
- Connect the Drain Hose insulated to the drain outlet. Drain hose should be go through under the Hose Bracket as shown in figure 4.
- Hang the drain hose on the hose hanger and fix it to the hole of the hose bracket with a screw.

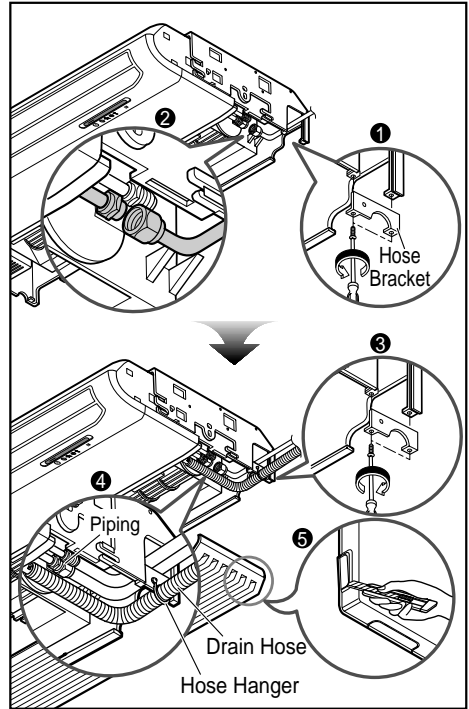

### 2. For the Bottom Side Piping

- Remove the knock-out on the bottomside of Inlet Grille
- Align the center of the pipings and sufficiently tighten the flare nut with fingers.
- Finally, tighten the flare nut with torque wrench until the wrench clicks.
- Connect the Drain Hose insulated to the drain outlet.
- Hang the drain hose on the hose hanger and fix it to the hole of cabinet bottom with a screw.

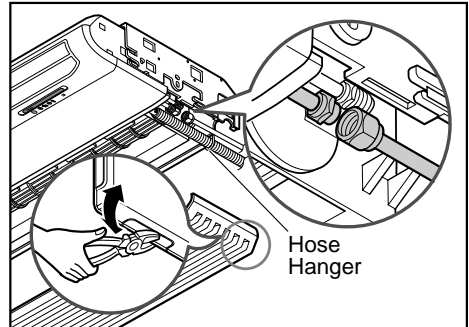

## Connecting the Drain Hose

- The drain hose can be connected to not only the right side but also left side of the unit.
- If the drain hose is connected to the left side, it should go through the cabinet bottom.
- Hang the drain hose on the hose hanger and fix it to the hole of cabinet bottom with a screw.

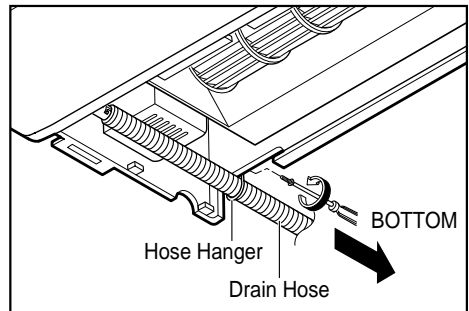

## Installation on the wall or floor (Connecting the pipes to the indoor unit)

### 1. For the Right Rear Piping

- Remove the knock-out at the back side of the cabinet.
- After bending an end of the connecting tube, align the center of the pipings and sufficiently tighten the flare nut with fingers.
- Finally, tighten the flare nut with torque wrench until the wrench clicks.
- Connect the Drain Hose insulated to the drain outlet.
- Tape the Drain Hose to the pipings to avoid coming off the drain-outlet.

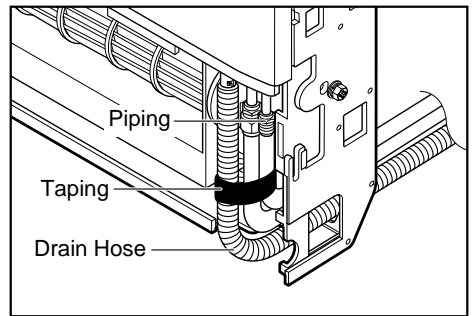

### 2. For the Right Side Piping

- After bending an end of the connecting tube, align the center of the pipings and sufficiently tighten the flare nut with fingers.
- Finally, tighten the flare nut with torque wrench until the wrench clicks.
- Connect the Drain Hose insulated to the drain outlet.
- Tape the Drain Hose to the pipings to avoid coming off the drain-outlet.

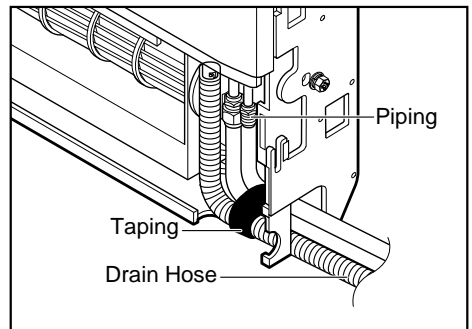

### 3. For the Right Bottom Piping

- Align the center of the pipings and sufficiently tighten the flare nut with fingers.
- Finally, tighten the flare nut with torque wrench until the wrench clicks.
- Connect the Drain Hose insulated to the drain outlet.

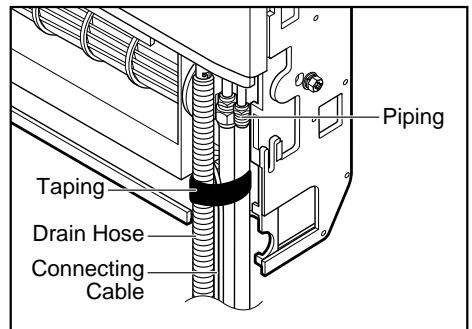

## Connecting the Drain Hose

- The drain hose can be connected to not only right side but also left side of the unit.

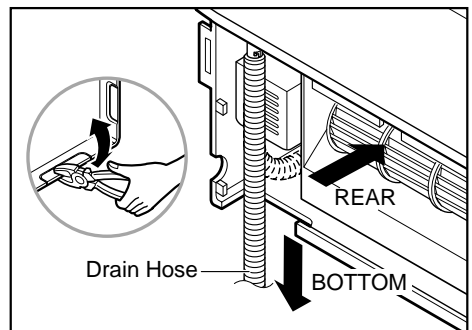

# Wired Remote Controller Installation

## DISASSEMBLING

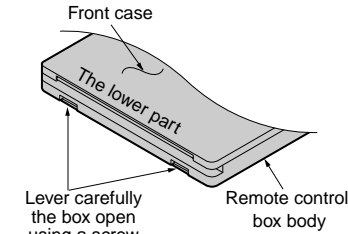

- Separate the under plate from Remote control box.

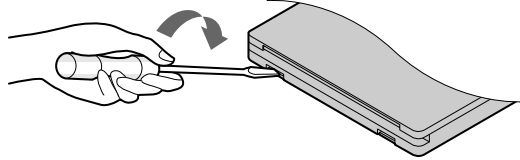

- Fix the under plate on the wall

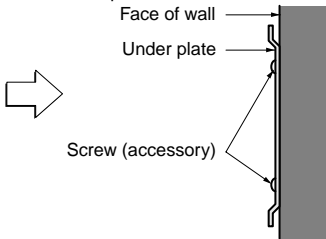

- Fix the cord clamps on the wall by  $\varnothing 3$  tapping screws (accessory).

- Fix the remote control cord.

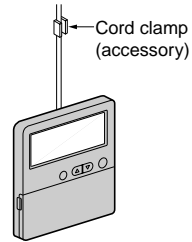
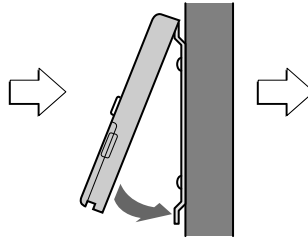

## ELECTRICAL WIRING

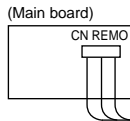

Wire and make sure that terminal numbers are matched on unit side and remote controller side.

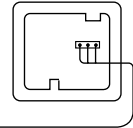

The maximum length of the cord is 100m.  
If the length of the cord exceeds 50m,  
use a wire size greater than 0.5mm<sup>2</sup>.

## Remote Controller Preparation (Convertible type)

### HOW TO MOUNT ONTO A WALL

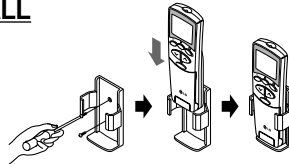

### HOW TO INSERT BATTERIES

1. Remove the battery cover from the remote controller.
  - Slide the cover according to the arrow direction.
2. Insert the two batteries.
  - Be sure that the (+) and (-) directions are correct.
  - Be sure that both batteries are new.
3. Re-attach the cover.
  - Slide it back into position.

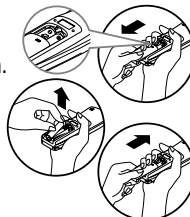

- Do not use rechargeable batteries, such batteries differ from standard dry cells in shape, dimensions, and performance.
- Remove the batteries from the remote controller if the air conditioner is not going to be used for some long time.

# Wiring Connection

- Open the control box cover and connect the Remote controller cord and Indoor power wires.

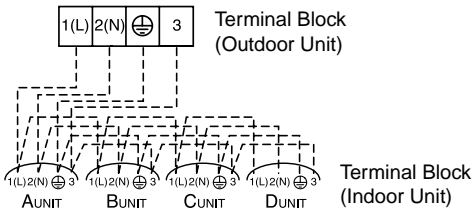
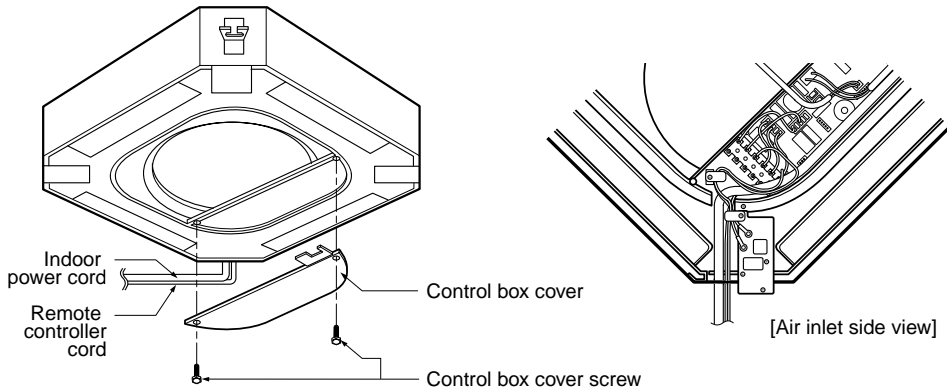

## ⚠ CAUTION

The power cord connected to the outdoor unit should be complied with the following specifications (Rubber insulation, type H05RN-F approved by HAR or SAA).

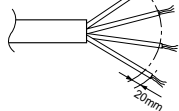

NORMAL  
CROSS-SECTIONAL  
AREA 5.5mm<sup>2</sup>

The connecting cable connected to the indoor and outdoor unit should be complied with the following specifications (Rubber insulation, type H05RN-F approved by HAR or SAA).

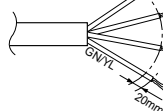

NORMAL  
CROSS-SECTIONAL  
AREA 1.25mm<sup>2</sup>

If the supply cord is damaged, it must be replaced by a special cord or assembly available from the manufacturer of its service agent.



## WARNING:

Make sure that the screws of the terminal are free from looseness.

## Electrical Wiring

1. All wiring must comply with LOCAL REGULATIONS.
2. Select a power source that is capable of supplying the current required by the air conditioner.
3. Feed the power source to the unit via a distribution switch board designed for this purpose.
4. The terminal screws inside the control box may be loose due to vibration during transport. Check the screws for loose connection.  
(Running the air conditioner with loose connection can overload and damage electrical components.)
5. Always ground the air conditioner with a grounding wire and connector to meet the LOCAL REGULATION.



### CAUTION:

- The circuit diagram is not subject to change without notice.
- Be sure to connect wires according to the wiring diagram.
- Connect the wires firmly, so that not to be pulled out easily.
- Connect the wires according to color codes by referring the wiring diagram.

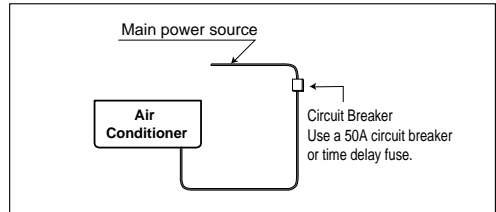

## Connecting the cable to Outdoor Unit

1. Remove the Cover control from the unit by loosening a screw.  
Connect the wires to the terminals on the control board individually as following.
2. Secure the cable onto the control board with the holder (clammer).
3. Refix the cover control to the original position with the screw.
4. Use a recognized circuit breaker between the power source and the unit. A disconnection device to adequately disconnect all supply lines must be fitted.

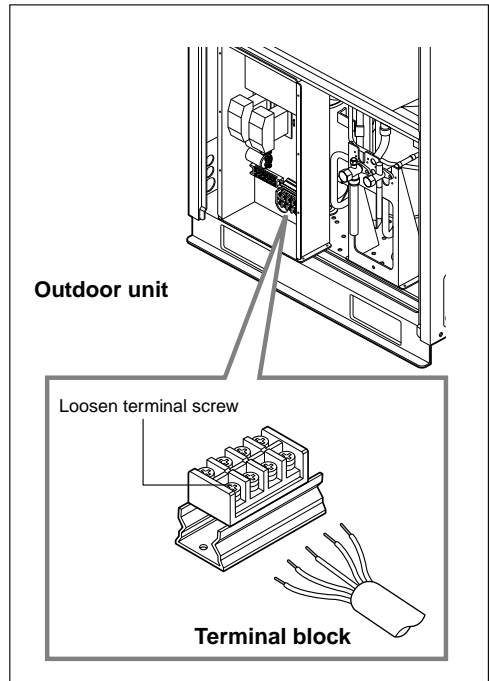

# Connecting Pipes to the Indoor Unit

## Preparation of Piping

Main cause of gas leakage is defect in flaring work. Carry out correct flaring work in the following procedure.

### 1. Cut the pipes and the cable.

- Use the accessory piping kit or the pipes purchased locally.
- Measure the distance between the indoor and the outdoor unit.
- Cut the pipes a little longer than measured distance.
- Cut the cable 1.5m longer than the pipe length.

### 2. Burrs removal

- Completely remove all burrs from the cut cross section of pipe/tube.
- Put the end of the copper tube/pipe to downward direction as you remove burrs in order to avoid to let burrs drop in the tubing.

### 3. Putting nut on

- Remove flare nuts attached to indoor and outdoor units, than put them on pipe/tube having completed burr removal.  
(Not possible to put them on after flaring work)

### 4. Flaring work

- Carry out flaring work using dedicated flaring tool for R-410A as shown below.

Outside diameter		A
mm	inch	mm
Ø6.35	1/4	0~0.5
Ø9.52	3/8	0~0.5
Ø12.7	1/2	0~0.5
Ø15.88	5/8	0~1.0
Ø19.05	3/4	0~1.0

Firmly hold copper tube in a bar(or die) as indicated dimension in the table above.

### 5. Check

- Compare the flared work with figure below.
- If flare is noted to be defective, cut off the flared section and do flaring work again.

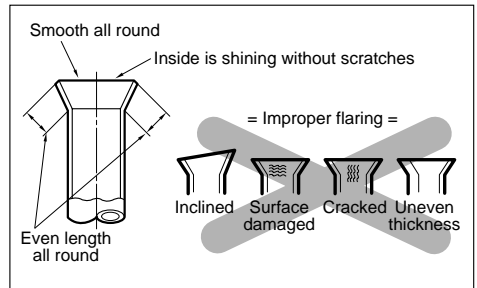
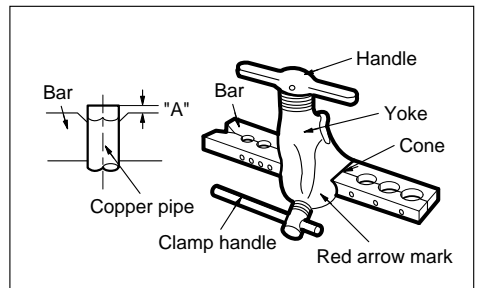
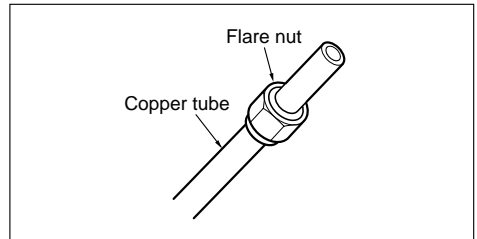
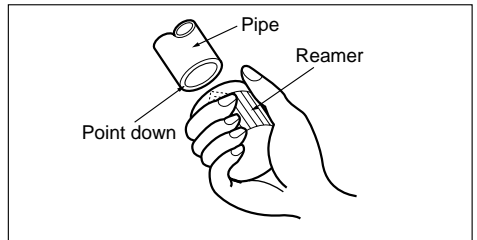
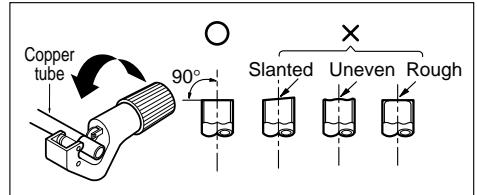

## Piping Connection

1. Form the piping according to its routing. Avoid bending and bending back the same piping point more than three times. (This will result in hardening the pipe.)
2. After deforming the piping, align centers of the union fitting of the indoor unit and the piping, and tighten them firmly with wrenches.
3. Connect pipe to the service valve or ball valve which is located below the outdoor unit.
4. After completing the piping connection, be sure to check if there is gas leakage in indoor and outdoor connection.

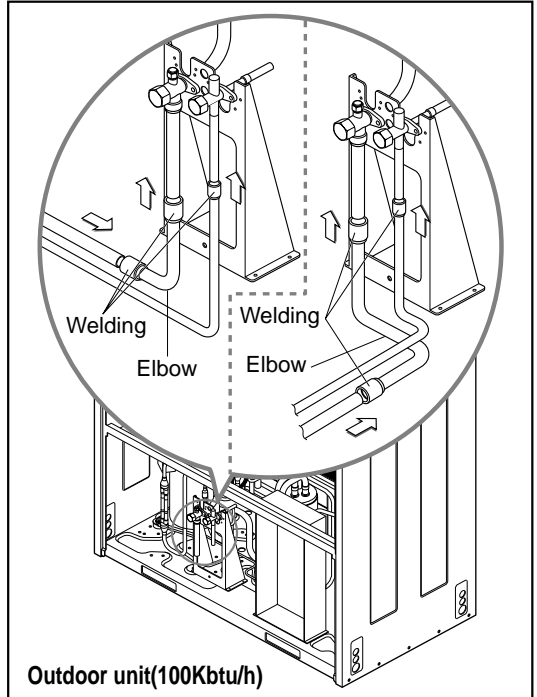
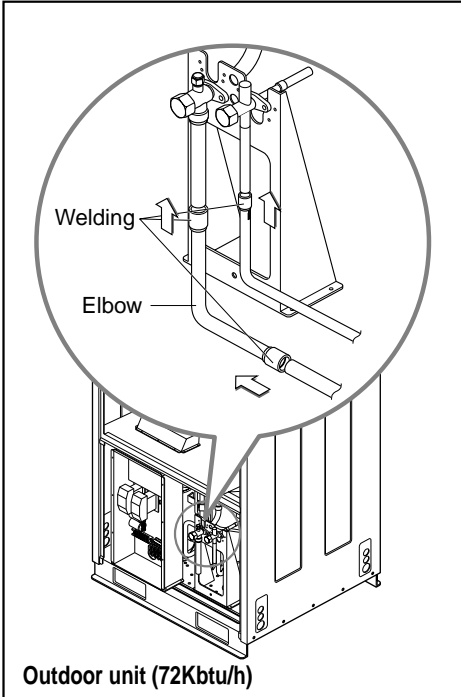

## Vacuum drying

After completing the piping connection, execute vacuum drying for the connecting piping and the indoor unit.

The vacuum drying must be carried out using the service ports of both the liquid and gas side valves.

**CAUTION:** Use two wrenches and tighten with regular torque.

Flare nut fastening torque	
Ø6.35mm	1.8kg·m
Ø9.52mm	4.0kg·m
Ø12.7mm	5.5kg·m
Ø15.88mm	6.6kg·m
Ø19.05mm	6.6kg·m

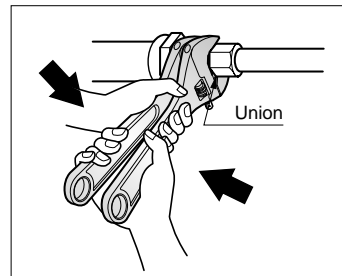

# Installation to Decorative Panel

**The decorative panel has its installation direction.**

**Before installing the decorative panel, always remove the paper template.**

1. Temporarily fix two decorative panel fixing screws (hexagon M5 screw) on the unit body. (Tighten by amount 10mm in length.)  
The fixing screws (hexagon M5 screw) are included the decorative panel box.
2. Remove the air inlet grille from the decorative panel. (Remove the hook for the air inlet grille cord.)
3. Hook the decorative panel key hole (  ) on the screws fixed in step above, and slide the panel so that the screws reach the key hole edge.
4. Retighten completely two temporarily fixed screws and other two screws. (Total 4 screws)
5. Connect the louver motor connector and display connector.
6. After tightening these screws, install the air inlet grille (including the air filter).

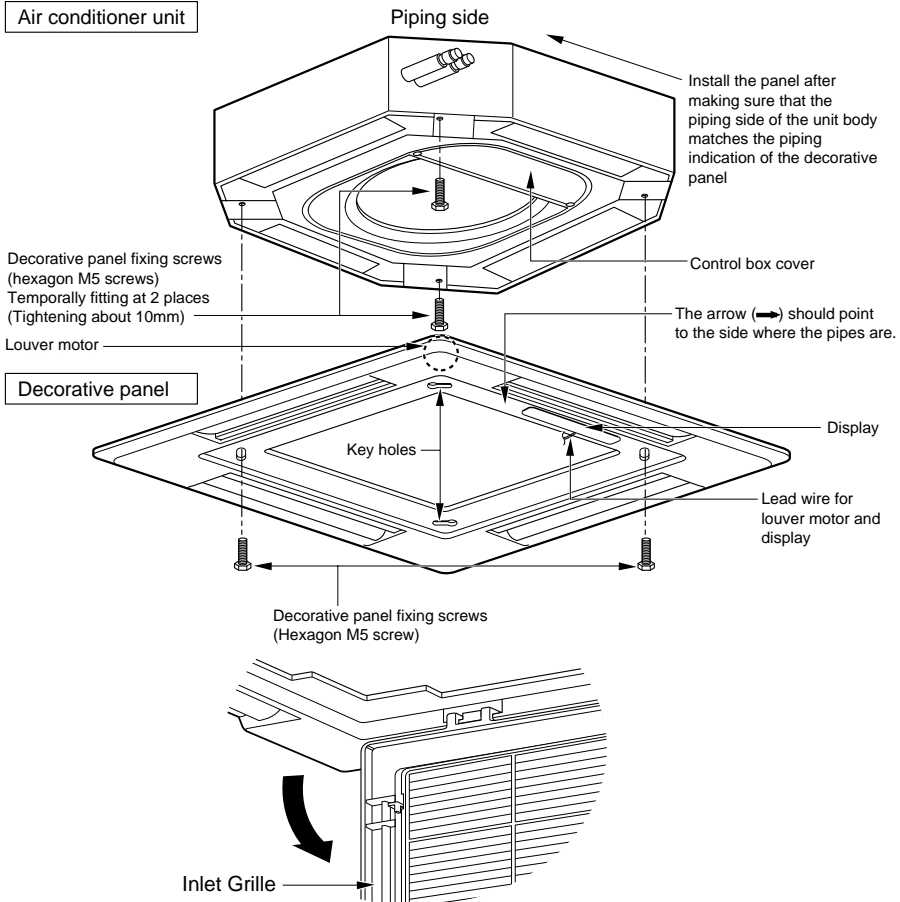



**CAUTION: Install certainly the decorative panel.**  
Cool air leakage causes sweating. ☞ Water drops fall.

### Good example

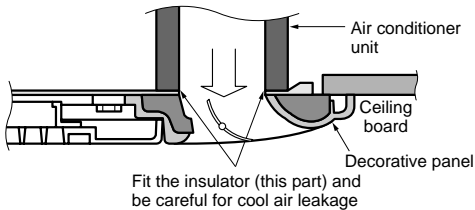

### Bad example

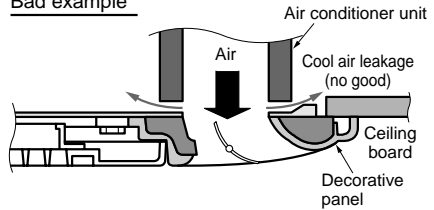

## Indoor Unit Drain Piping

- Drain piping must have down-slope (1/50 to 1/100): be sure not to provide up-and-down slope to prevent reversal flow.
- During drain piping connection, be careful not to exert extra force on the drain port on the indoor unit.
- The outside diameter of the drain connection on the indoor unit is 32mm.

Piping material: Polyvinyl chloride pipe VP-25 and pipe fittings

- Be sure to execute heat insulation on the drain piping.
- Install the drain raising pipes at a right angle to the indoor unit and no more than 300mm from the unit.

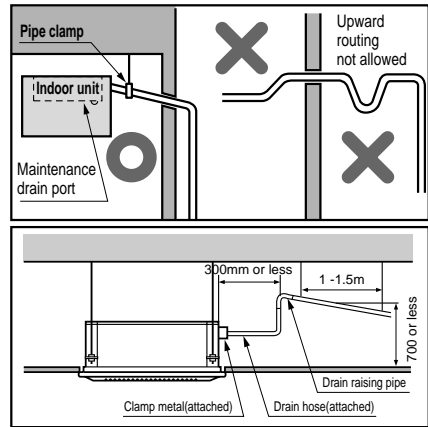

Heat insulation material: Polyethylene foam with thickness more than 8 mm.

## Drain test

The air conditioner uses a drain pump to drain water.  
Use the following procedure to test the drain pump operation:

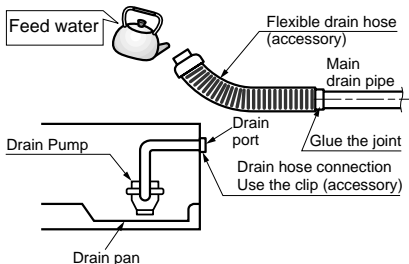

- Connect the main drain pipe to the exterior and leave it provisionally until the test comes to an end.
- Feed water to the flexible drain hose and check the piping for leakage.
- Be sure to check the drain pump for normal operating and noise when electrical wiring is complete.
- When the test is complete, connect the flexible drain hose to the drain port on the indoor unit.

## Heat insulation

1. Use the heat insulation material for the refrigerant piping which has an excellent heat-resistance (over 120°C).
2. Precautions in high humidity circumstance:

This air conditioner has been tested according to the "KS Standard Conditions with Mist" and confirmed that there is not any default. However, if it is operated for a long time in high humid atmosphere (dew point temperature: more than 23°C), water drops are liable to fall. In this case, add heat insulation material according to the following procedure:

- Heat insulation material to be prepared...  
Adiabatic glass wool with thickness 10 to 20mm.
- Stick glass wool on all air conditioners that are located in ceiling atmosphere.

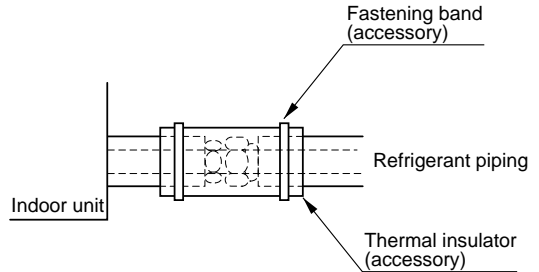

## Forming the piping

**Form the piping by wrapping the connecting portion of the indoor unit with insulation material and secure it with two kinds of vinyl tape.**

- If you want to connect an additional drain hose, the end of the drain outlet should be routed above the ground. Secure the drain hose appropriately.

**In cases where the outdoor unit is installed below the indoor unit perform the following.**

1. Tape the piping, drain hose and connecting cable from down to up.
2. Secure the tapped piping along the exterior wall using saddle or equivalent.

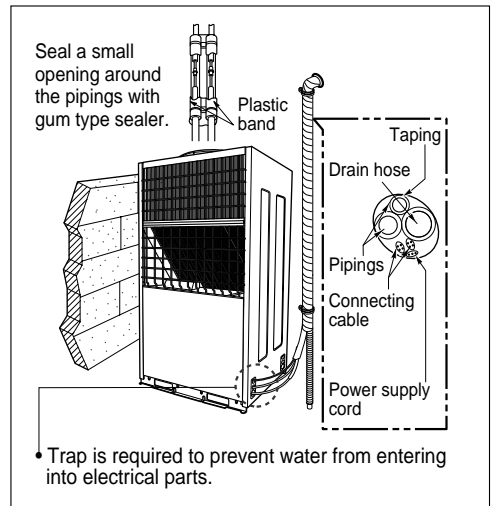

**In cases where the Outdoor unit is installed above the Indoor unit perform the following.**

1. Tape the piping and connecting cable from down to up.
2. Secure the taped piping along the exterior wall. Form a trap to prevent water entering the room.
3. Fix the piping onto the wall by saddle or equivalent.

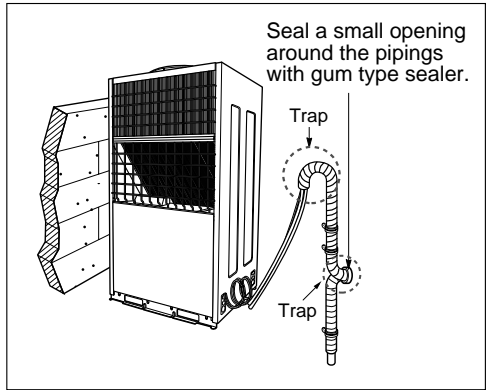

# Test running

## 1. PRECAUTIONS IN TEST RUNNING

- The initial power supply must provide at least 90% of the rated voltage. Otherwise, the air conditioner should not be operated.



**CAUTION** ① For test run, carry out the cooling operation firstly even during heating season. If heating operation is carried out firstly, it leads to the trouble of compressor. Then attention must be paid.

② Carry out the test run more than 5 minutes without fail.  
(Test run will be cancelled 18 minutes later automatically)

- The test run is started by pressing the room temperature checking button and down timer button for 3 seconds at the same time.
- To cancel the test run, press any button.

## CHECK THE FOLLOWING ITEMS WHEN INSTALLATION IS COMPLETE

- After completing work, be sure to measure and record trial run properties, and store measured data, etc.
- Measuring items are room temperature, outside temperature, suction temperature, blow out temperature, wind velocity, wind volume, voltage, current, presence of abnormal vibration and noise, operating pressure, piping temperature, compressive pressure.
- As to the structure and appearance, check following items.

- Is the circulation of air adequate?
- Is the draining smooth?
- Is the heat insulation complete (refrigerant and drain piping)?
- Is there any leakage of refrigerant?

- Is the remote controller switch operated?
- Is there any faulty wiring?
- Are not terminal screws loosened?

M4.....118N·cm{12kgf·cm}    M5.....196N·cm{20kgf·cm}  
M6.....245N·cm{25kgf·cm}    M8.....588N·cm{60kgf·cm}

## 2. Connection of power supply

### 1. Connect the power supply cord to the independent power supply.

- Circuit breaker is required.

### 2. Operate the unit for fifteen minutes or more.

## 3. Evaluation of the performance

1. Measure the temperature of the intake and discharge air.
2. Ensure the difference between the intake temperature and the discharge one is more than 8°C (Cooling) or reversely (Heating).

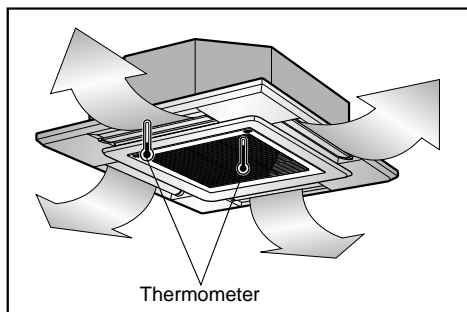



**CAUTION:** After the confirmation of the above conditions, prepare the wiring as follows:

- 1) Never fail to have an individual power specialized for the air conditioner. As for the method of wiring, be guided by the circuit diagram pasted on the inside of control box cover.
- 2) Provide a circuit breaker switch between power source and the unit.
- 3) The screw which fasten the wiring in the casing of electrical fittings are liable to come loose from vibrations to which the unit is subjected during the course of transportation. Check them and make sure that they are all tightly fastened. (If they are loose, it could give rise to burn-out of the wires.)
- 4) Specification of power source
- 5) Confirm that electrical capacity is sufficient.
- 6) Be sure that the starting voltage is maintained at more than 90 percent of the rated voltage marked on the name plate.
- 7) Confirm that the cable thickness is as specified in the power sources specification.  
(Particularly note the relation between cable length and thickness.)
- 8) Never fail to equip a leakage breaker where it is wet or moist.
- 9) The following troubles would be caused by voltage drop-down.
  - Vibration of a magnetic switch, damage on the contact point there of, fuse breaking, disturbance to the normal function of a overload protection device.
  - Proper starting power is not given to the compressor.
- 10) Use only 1 remote-controller contained in the Cassette type indoor unit, when you combine to use both cassette type indoor unit and different kind of indoor unit.  
After setting the ESP value in the Duct Type Indoor Unit, the main power turns off and then remove the remote controller.

## **HAND OVER**

Teach the customer the operation and maintenance procedures, using the operation manual (air filter cleaning, temperature control, etc.).

# Optional Operation

## 1. Two Thermistor System

- (1) Open the rear cover of the wired remote-controller to set the mode.
- (2) Select one of three selectable modes as follows.
  - Position 1: The room temperature is controlled by the thermistor of the main body.
  - Position 2: The room temperature is controlled by the thermistor of the wired remote-controller, control the temperature according to the position of wired remote-controller.
  - Position 3: The room temperature is controlled by lower temperature between the temperature of main body and of remote-controller sensor.
- (3) Move the slide switch to set position.

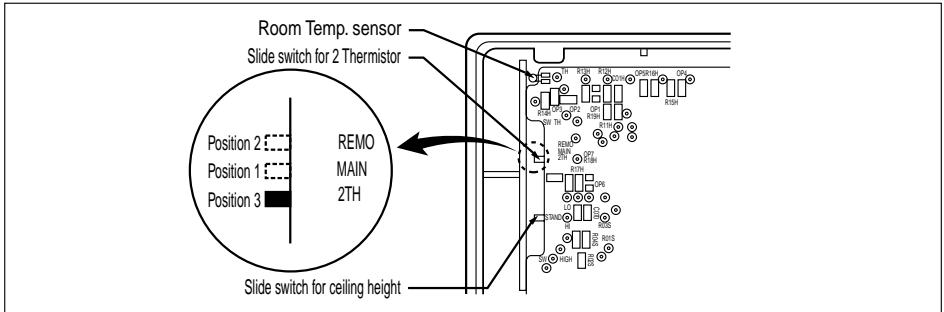

- (4) Close the rear cover and check if it works normally.



### CAUTION:

- Select the position after counselling with a customer.
- In case of cooling mode, room temperature is controlled by the main body sensor.
- To control the room temperature by a wired remote controller, install controller(room temp. sensor) to sense the temperature more accurately.
- Manufactured in the position 3.

## 2. Adjusting air volume to the height of ceiling (Cassette type)

You can choose the RPM(or air volume) of indoor motor according to the height of ceiling to supply the comfortable atmosphere to consumers.

### Procedure

1. Choose the selectable position in the table after measuring the height of ceiling.

Ceiling height	Mode of slide switch	Change of air volume	Remark
more than 3.3m	High Ceiling	Increasing	Manufactured in standard mode
2.7~3.3m	Standard	-	
less than 2.7m	Low Ceiling	Decreasing	

2. In the case of changing the height as "high" or "low", open the rear cover of the wired remote-controller.
3. Move the slide switch to the set position.

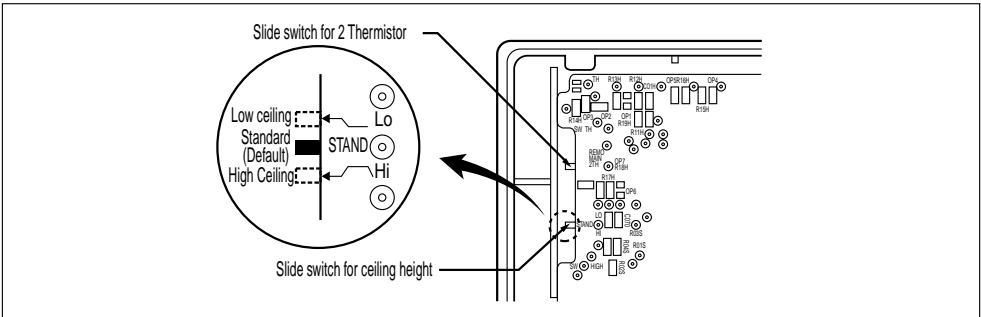

4. Close the rear cover and check if it works normally.

### 3. E.S.P.(External Static Pressure) Setting (Duct type)

- (1) Open the rear cover of the wired remote-controller to set the mode.
- (2) Select one of three selectable modes as follows.

#### ■ Without Zone System

1. Position V-H, F-H:
  - This position sets the maximum E.S.P as a default set.
2. Position V-L:
  - This position sets the minimum E.S.P as a default set.

#### ■ With Zone System

1. Position V-H:
  - Maximum E.S.P setting & Fan speed is varied according to the state of dampers by micom.
2. Position F-H:
  - Maximum E.S.P setting & Fan speed doesn't vary according to the opening & Closing of dampers.
3. Position V-L:
  - Minimum E.S.P setting & Fan speed is varied according to the state of dampers by micom.

\* Maximum : 24K-6mmAq  
Minimum : 0mmAq

- (3) Move the slide switch to set position.

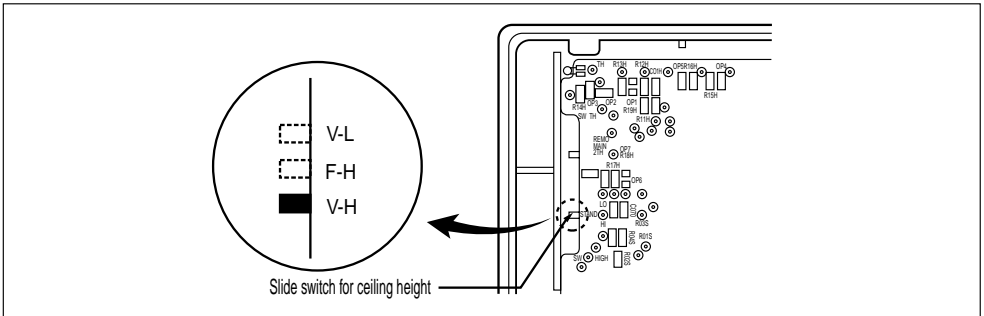

- (4) Close the rear cover and check if it works normally.



#### CAUTION:

- Select the position after checking duct work and E.S.P of the unit.
- Manufactured in the position F-H.

## 4. How to Set E.S.P?

### Procedure of RPM change:

Ex) External Static pressure is 6mmAq for 36k.

- To protect the unit, compressor is designed to be off during E.S.P. setting.

- 1** Push the "On/Off" button.  
The unit will start.

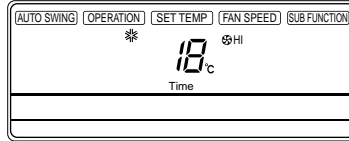
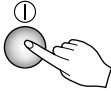

- 2** Push the "Timer" and "Wind" button simultaneously for more then 3 seconds.

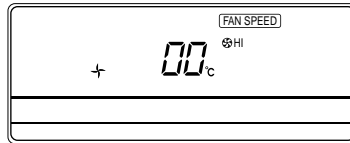
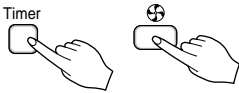

- 3** Push the "Up" of "Down" button for E.S.P adjustment.  
And, adjust the number which you want.(In this example, the number is "220". Refer to the table 1 on the next page.)

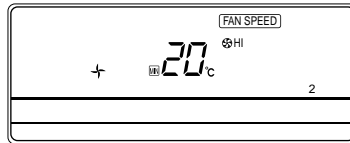
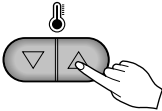

**Note:** The range of selection is from 1~254. Since, the display is two Digit only.  
If the range selection is above 100 then the third digit will appear in the screen as shown.

- 4** Shift the fan speed mode by pressing the fan speed button.  
And then, Adjust numbers of next steps by repeating the stage 3.  
(In this example, the numbers are "235" and "243" respectively)



- 5** Push the "Timer" and "Wind" button simultaneously for more than 3 seconds.  
Then, Wind Data is memorized by the EEPROM of the main PCB.

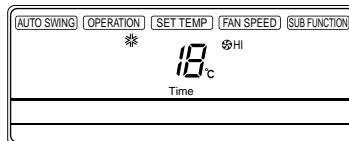

**[Table. 1]**

Static Pressure(mmAq)			0	2	4	6	8	10	12	14	15
Model Name	Step	CMM(CFM)	Setting Value								
18K	High	16.5(583)	235	230	225	215	180				
	Med	14.5(512)	245	238	235	230	215				
	Low	13(459)	254	252	248	245	240				
24K	High	18(636)	220	205	190	50	1				
	Med	16.5(583)	235	230	220	200	100				
	Low	14(494)	250	240	235	230	210				
30K	High	26.5(936)	153	150	150	148	130	1			
	Med	23(812)	173	173	175	175	170	155			
	Low	20(706)	190	190	190	190	190	190			
36K	High	32(1130)	230	230	225	220	150	1			
	Med	29(1024)	240	238	237	235	230	220			
	Low	26.5(936)	245	245	243	243	240	240			
48K	High	40(1412)	230	225	220	215	205	200	190	180	160
	Med	35(1235)	250	245	240	235	230	220	215	210	200
	Low	30(1059)	255	255	255	250	245	240	235	230	225
60K	High	50(1766)	185	180	174	162	154	140	90	5	1
	Med	45(1589)	210	205	199	191	189	180	155	138	110
	Low	40(1423)	230	225	219	215	210	205	193	180	171

**Note: 1. Be sure to set the value referring table 1. Unexpected set value will cause mal-function.**

**2. Table 1 is based at 230V. According to the fluctuation of voltage, air flow rate varies.**

## 5. Outdoor Unit PCB Setting Procedure

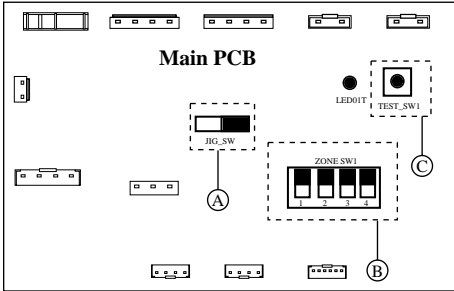

Fig.a Outdoor PCB diagram

1. JIG\_SW Setting Check the JIG\_SW to the right, or not set the JIG\_SW to the right.( A )
2. ZONE SW1 Setting Set the ZONE SW1 as below Table.a ( B )

※ S/W1 is not used.

※ 1 means S/W up.0 means S/W down.

Table.a ZONE SW1 Setting

ZONE SW1	Indoor Unit No.
	2(Duo)
	3(Trio)
	4(Quartet)

3. Auto Addressing Method Addressing work assigns address to each indoor unit. When firstly installing product or replacing the indoor unit PCB. Auto Addressing work should be done for simultaneous operation.

※ Work procedure

- 1) Set JIG\_SW and ZONE SW1 correctly.
- 2) Turn on main power.
- 3) Press the TEST\_SW1 for about 3 seconds within 3minutes After main power on.( C )
- 4) After step 3), the LED01T(green LED) rapidly flickers. When Addressing work is done, green LED is off, else LED stops flickering and lights continuously.
- 5) If you fail to perform the Addressing work, repeat step 2),3).