

# FLEX MULTI SPLIT DUAL ZONE & TRI-ZONE INSTALLATION INSTRUCTIONS

ENGLISH

FRANÇAIS

ESPAÑOL

## IMPORTANT!

**Please read this instruction sheet completely before installing the product.**

This air conditioning system meets strict safety and operating standards. As the installer or service person, it is an important part of your job to install or service the system so it operates safely and efficiently.



### WARNING

- Installation or repairs made by unqualified persons can result in hazards to you and others. Installation **MUST** conform with local building codes or, in the absence of local codes, with the National Electrical Code NFPA 70/ANSI C1-1993 or current edition and Canadian Electrical Code Part1 CSA C.22.1.
- The information contained in the manual is intended for use by a qualified service technician familiar with safety procedures and equipped with the proper tools and test instruments.
- Failure to carefully read and follow all instructions in this manual can result in equipment malfunction, property damage, personal injury and/or death.

**CAUTION:** Improper installation, adjustment, alteration, service or maintenance can void the warranty.

The weight of the condensing unit requires caution and proper handling procedures when lifting or moving to avoid personal injury. Use care to avoid contact with sharp or pointed edges.

### Safety Precautions

- Always wear safety eye wear and work gloves when installing equipment.
- Do not supply power to the unit until all wiring and tubing are completed or reconnected and checked.
- Keep hands out of fan areas when power is connected to equipment.
- R-410A causes frostbite burns.
- R-410A is toxic when burned.

**NOTE TO INSTALLING DEALER:** The Owners Instructions and Warranty are to be given to the owner or prominently displayed near the indoor Furnace/Air Handler Unit.



### Special warnings

#### When wiring:

**Electrical shock can cause severe personal injury or death. Only a qualified, experienced electrician should attempt to wire this system.**

- Do not supply power to the unit until all wiring and tubing are completed or reconnected and checked.
- Highly dangerous electrical voltages are used in this system. Carefully refer to the wiring diagram and these instructions when wiring. Improper connections and inadequate grounding can cause accidental injury or death.
- Ground the unit following local electrical codes.
- Connect all wiring tightly. Loose wiring may cause overheating at connection points and a possible fire hazard.

#### When transporting:

Be careful when picking up and moving the indoor and outdoor units. Get a partner to help, and bend your knees when lifting to reduce strain on your back. Sharp edges or thin aluminum fins on the air conditioner can cut your finger.

#### When installing...

... **in a wall:** Make sure the wall is strong enough to hold the unit's weight.

It may be necessary to construct a strong wood or metal frame to provide added support.

... **in a room:** Properly insulate any tubing run inside a room to prevent "sweating" that can cause dripping and water damage to wall and floors.

... **in moist or uneven locations:** Use a raised concrete pad or concrete blocks provide a solid, level foundation for the outdoor unit. This prevents water damage and abnormal vibration.

... **in an area with high winds:** Securely anchor the outdoor unit down with bolts and a metal frame. Provide a suitable air baffle.

... **in a snowy area(for Heat Pump Model):** Install the outdoor unit on a raised platform that is higher than drifting snow. Provide snow vents.

#### When connecting refrigerant tubing

- Keep all tubing runs as short as possible.
- Use the flare method for connecting tubing.
- Check carefully for leaks before starting the test run.

#### When servicing

- Turn the power OFF at the main power box(mains) before opening the unit to check or repair electrical parts and wiring.
- Keep your fingers and clothing away from any moving parts.
- Clean up the site after you finish, remembering to check that no metal scraps or bits of wiring have been left inside the unit being serviced.

# TABLE OF CONTENTS

## ***Installation Requirements***

**Installation Parts Provided** .....3

**Safety Precautions** .....4

**Installation of Indoor, Outdoor Unit**.....7

    Select the best location .....7

    Installation guide at the seaside.....8

    Piping length and elevation .....9

    Fixing Installation Plate(Standart Type).....10

    Preparing work for Installation (Artcool Type Only) ....11

    Sticking the installation guide map  
    and fixing Indoor unit (Artcool Type Only) .....12

    Drill a hole in the wall .....12

**Flaring Work and Connection of Piping**.....13

    Flaring work.....13

    Connecting the Piping .....14

**Connecting the Cable between Indoor Unit  
and Outdoor Unit**.....20

    Connect the cable to the Indoor unit. ....20

    Connect the cable to the Outdoor unit. ....21

    Connection method of the connecting  
    cable(Example).....22

    Connect the cable to the indoor unit(For SE, S4  
    Chassis).....23

    Checking the Drainage, Forming the Piping and  
    Long Pipe Setting.....24

    Checking the drainage.....24

    Forming the piping.....25

**Air Purging and Evacuation** .....26

    Checking method.....26

    Evacuation.....27

**Charging**.....28

**Panel Front Assembly (Artcool type Only)**.....29

**Test Running**.....30

**Combination indoor units** .....31



**Combination table of Models** .....32

## ***Required Tools***

- Level gauge
- Screw driver
- Electric drill
- Hole core drill (ø50mm)
- Horizontal meter
  
- Flaring tool set
- Specified torque wrenches  
    1.8kg.m, 4.2kg.m, 5.5kg.m, 6.6kg.m  
    (different depending on model No.)
- Spanner .....Half union
  
- A glass of water
- Screw driver
  
- Hexagonal wrench(4mm)
- Gas-leak detector
- Vacuum pump
- Gauge manifold
  
- Owner's manual
- Thermometer
- Holder Remote Control

# Installation Parts Provided

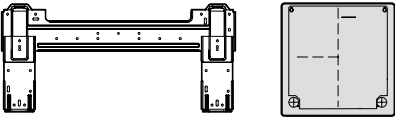
## Standard Type

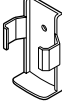
<p>Installation plate</p> 	<p>Type "A" screws and plastic anchors</p> 
<p>Type "B" screws</p> 	<p>Holder Remote Control</p> 

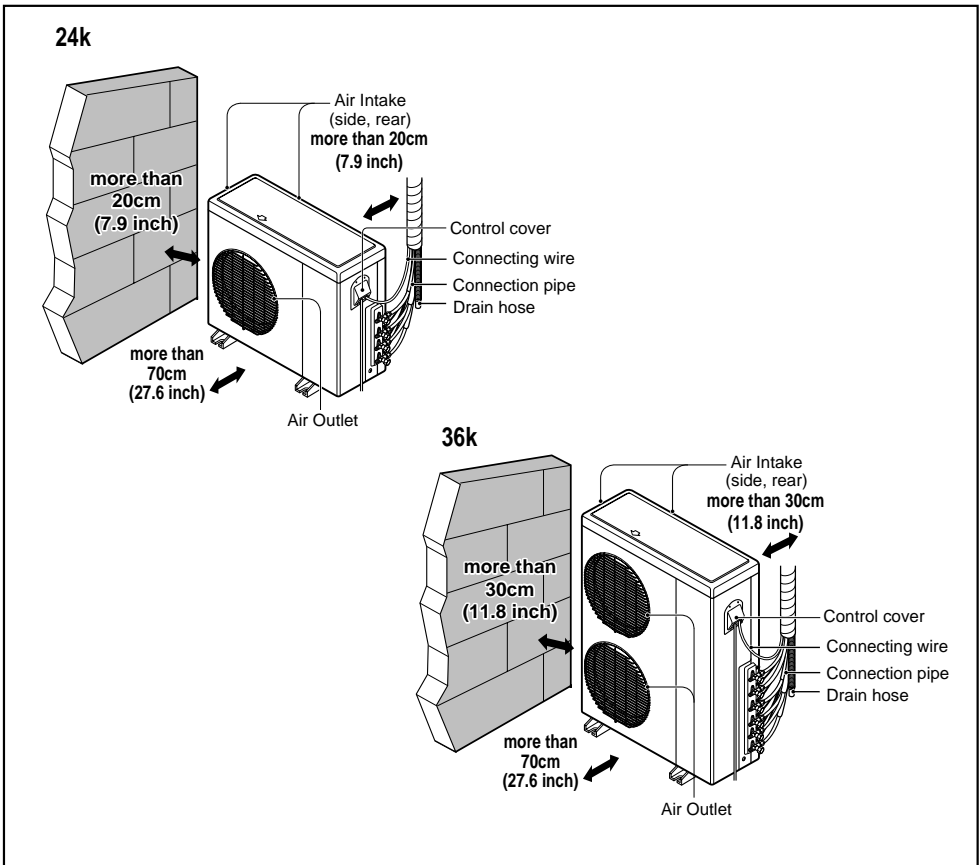

# Safety Precautions



To prevent injury to the user or other people and property damage, the following instructions must be followed.

■ Incorrect operation due to ignoring instruction will cause harm or damage. The seriousness is classified by the following indications.

**⚠ WARNING** This symbol indicates the possibility of death or serious injury.

**⚠ CAUTION** This symbol indicates the possibility of injury or damage.

■ Meanings of symbols used in this manual are as shown below.

	<b>Be sure not to do.</b>
	<b>Be sure to follow the instruction.</b>

## ⚠ WARNING

### ■ Installation

**Do not use a defective or underrated circuit breaker. Use this appliance on a dedicated circuit.**

- There is risk of fire or electric shock.

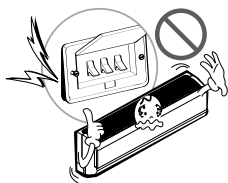

**For electrical work, contact the dealer, seller, a qualified electrician, or an Authorized Service Center.**

- Do not disassemble or repair the product. There is risk of fire or electric shock.



**Always ground the product.**

- There is risk of fire or electric shock.

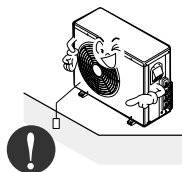

**Install the panel and the cover of control box securely.**

- There is risk of fire or electric shock.

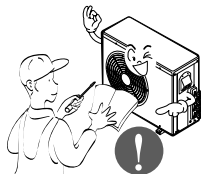

**Always install a dedicated circuit and breaker.**

- Improper wiring or installation may cause fire or electric shock.

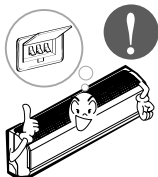

**Use the correctly rated breaker or fuse.**

- There is risk of fire or electric shock.

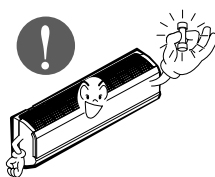

**Do not modify or extend the power cable.**

- There is risk of fire or electric shock.

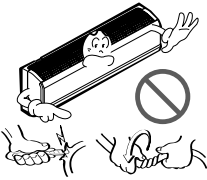

**Be cautious when unpacking and installing the product.**

- Sharp edges could cause injury. Be especially careful of the case edges and the fins on the condenser and evaporator.



**For installation, always contact the dealer or an Authorized Service Center.**

- There is risk of fire, electric shock, explosion, or injury.

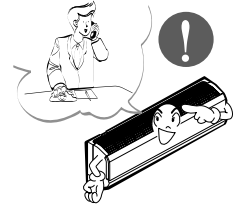

**Do not install the product on a defective installation stand.**

- It may cause injury, accident, or damage to the product.

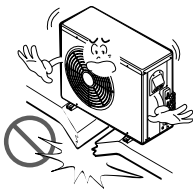

**Be sure the installation area does not deteriorate with age.**

- If the base collapses, the air conditioner could fall with it, causing property damage, product failure, and personal injury.

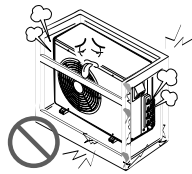

**Do not let the air conditioner run for a long time when the humidity is very high and a door or a window is left open.**

- Moisture may condense and wet or damage furniture.



## ■ Operation

**Do not store or use flammable gas or combustibles near the product.**

- There is risk of fire or failure of product.



## CAUTION

### ■ Installation

Always check for gas (refrigerant) leakage after installation or repair of product.

- Low refrigerant levels may cause failure of product.

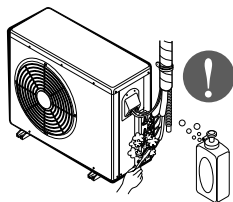

Install the drain hose to ensure that water is drained away properly.

- A bad connection may cause water leakage.

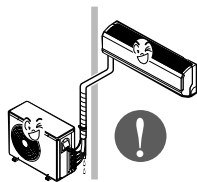

Keep level even when installing the product.

- To avoid vibration or water leakage.

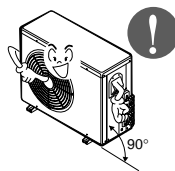

Do not install the product where the sound or hot air from the outdoor unit could be offensive to neighbors.

- It may cause a problem for your neighbors.



Use two or more people to lift and transport the product.

- Avoid personal injury.

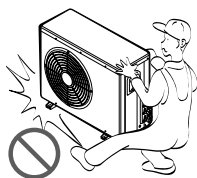

Do not install the product where it will be exposed to salt spray directly.

- It may cause corrosion on the product. Corrosion, particularly on the condenser and evaporator fins, could cause product malfunction or inefficient operation.

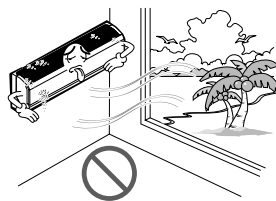

# Installation of Indoor, Outdoor Unit

Read completely, then follow step by step.

## Select the best location

### Indoor unit

1. Do not have any heat or steam near the unit.
2. Select a place where there are no obstacles in front of the unit.
3. Make sure that condensation drainage can be conveniently routed away.
4. Do not install near a doorway.
5. Ensure the spaces indicated by arrows from the wall, ceiling, fence or other obstacles.
6. Use a stud finder to locate studs to prevent unnecessary damage to the wall.



**CAUTION: Install the indoor unit on the wall where the height from the floors more than 2.3m(7.5ft).**

### Outdoor unit

1. If an awning is built over the unit to prevent direct sunlight or rain exposure, make sure that heat radiation from the condenser is not restricted.
2. Ensure that the spaces indicated by arrows around front, back and side of the unit.
3. Do not place animals and plants in the path of the warm air.
4. Take the air conditioner weight into account and select a place where noise and vibration are minimum.
5. Select a place so that the warm air and sound from the air conditioner do not disturb neighbors.

### Rooftop Installations:

If the outdoor unit is installed on a roof structure, be sure to level the unit. Ensure the roof structure and anchoring method are adequate for the unit location. Consult local codes regarding rooftop mounting.

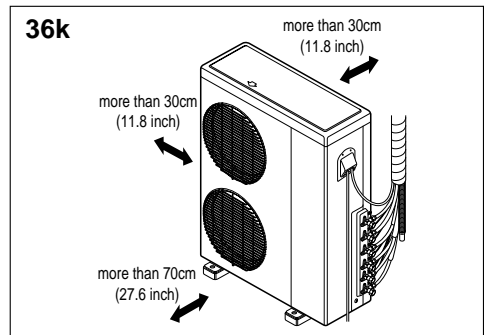
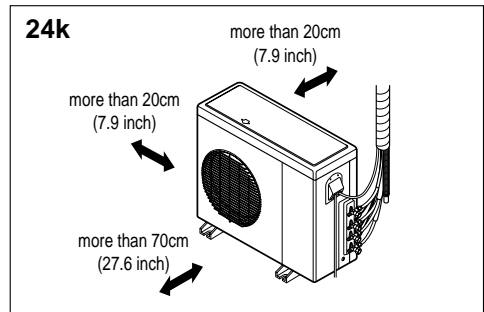
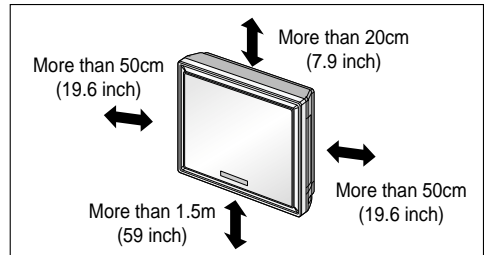
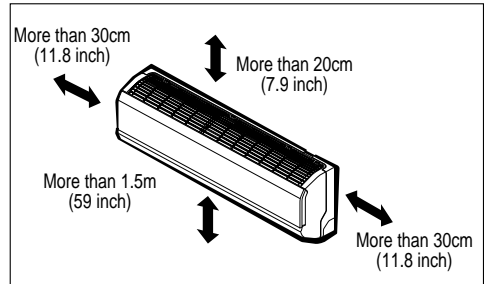

## Installation guide at the seaside

### ⚠ CAUTION

1. Air conditioners should not be installed in areas where corrosive gases, such as acid or alkaline gas, are produced.
2. Do not install the product where it could be exposed to sea wind (salty wind) directly. It can result corrosion on the product. Corrosion, particularly on the condenser and evaporator fins, could cause product malfunction or inefficient performance.
3. If outdoor unit is installed close to the seaside, it should avoid direct exposure to the sea wind. Otherwise it needs additional anticorrosion treatment on the heat exchanger.

### 1. Selecting the location(Outdoor Unit)

- 1) If the outdoor unit is to be installed close to the seaside, direct exposure to the sea wind should be avoided. Install the outdoor unit on the opposite side of the sea wind direction.

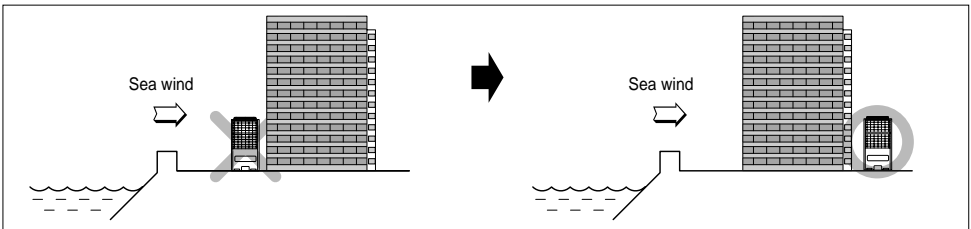

- 2) In case, to install the outdoor unit on the seaside, set up a windbreak not to be exposed to the sea wind.

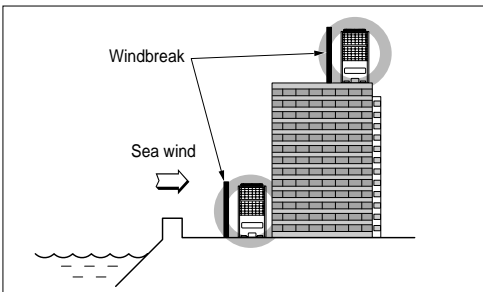

- It should be strong enough like concrete to prevent the sea wind from the sea.
- The height and width should be more than 150% of the outdoor unit.
- It should be keep more than 70 cm of space between outdoor unit and the windbreak for easy air flow.

- 3) Select a well-drained place.

1. If you can't meet above guide line in the seaside installation, please contact LG Electronics for the additional anticorrosion treatment.
2. Periodic ( more than once/year ) cleaning of the dust or salt particles stuck on the heat exchanger by using water

# Piping length and elevation

## Multi Piping Type

Capacity(Btu/h)	Max total length of all pipes (A+B/A+B+C)	Max length of each pipe (A/B/C)	Min length of each pipe (A/B/C)	Max Elevation between each indoor unit and outdoor unit (h1)	Max elevation between indoor units (h2)
24k	30m(100ft)	15m(50ft)	3m(10ft)	7.5m(25ft)	7.5m(25ft)
36k	45m(150ft)	15m(50ft)	3m(10ft)	7.5m(25ft)	7.5m(25ft)

Indoor Capacity (Btu/h)	Pipe Size			
	Gas	Liquid	Standard Length	Additional Refrigerant
9k	9.52mm(3/8")	6.35mm(1/4")	7.5m(25ft)	20g/m(0.22oz/ft)
12k	9.52mm(3/8")	6.35mm(1/4")	7.5m(25ft)	20g/m(0.22oz/ft)

24k

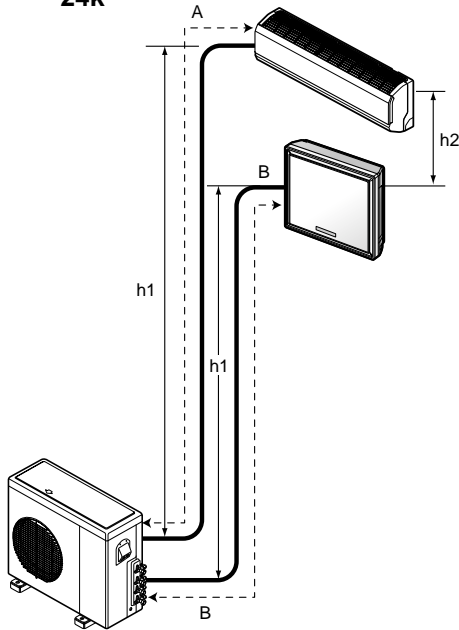

36k

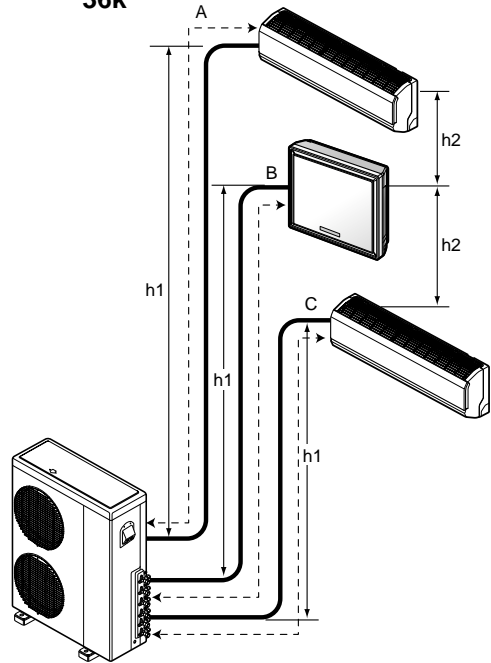

**CAUTION:** Capacity is based on standard length and maximum allowance length is on the basis of reliability.

## Fixing Installation Plate(Standart Type)

The wall you select should be strong and solid enough to prevent vibration

1. Mount the installation plate on the wall with type "A" screws. If mounting the unit on a concrete wall, use anchor bolts.
  - Mount the installation plate horizontally by aligning the centerline using a level.

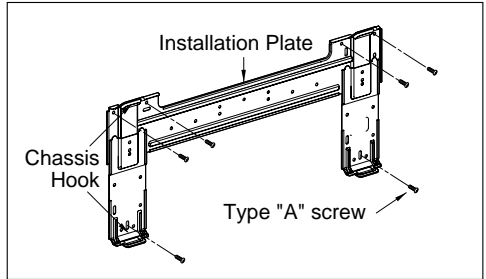

2. Measure the wall and mark the centerline. It is also important to use caution concerning the location of the installation plate-routing of the wiring to power outlets is through the walls typically. Drilling the hole through the wall for piping connections must be done safely.

CHASSIS (Grade)	Distance (mm)			
	A	B	C	D
S4	50	105	59	105
SE	65	110	85	110

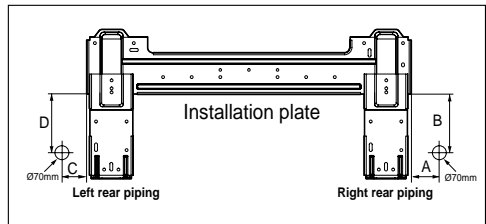

## Preparing work for Installation (Artcool Type Only)

### Open panel front

1. First, push the front panel backward and lift it up to remove the two screws.
2. The moment of lifting the both lower parts of panel front, you can hear sound this panel came out, In this time panel front is separated
3. After pull down this panel a bit, and separate connecting wire with product.

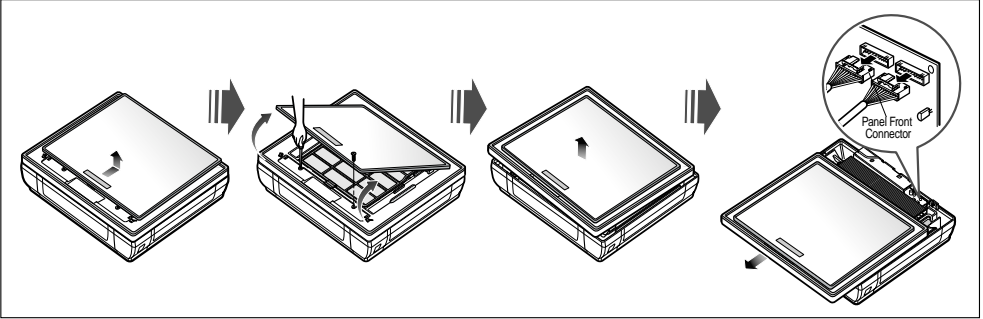

### Remove cover pipe and cover side

1. Remove two screws (for fixing cover pipe)
2. Pull up the cover side of desired connecting direction, then cover side is separated.
3. In case of connecting direction is left or right, path through the hole of cover side.

**CAUTION:** After removing the pipe hole, cut the burr for safety.

**NOTICE** When connecting pipe path through rear wall, don't remove the hole.

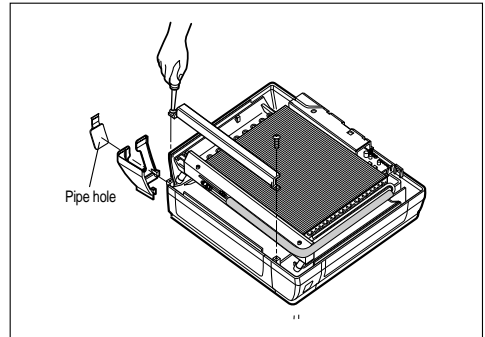

### Drain hose junction

1. Remove the rubber stopple of desired direction of drainage.
2. As the following picture, Insert drain hose in the handle of drain pan, and join drain hose and connecting hose.

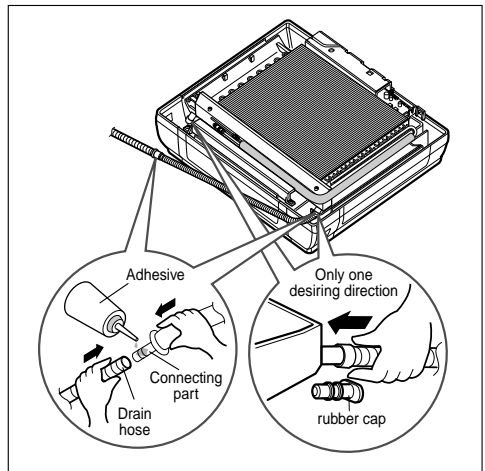

**Sticking the installation guide map and fixing Indoor unit (Artcool Type Only)**

Put an Installation Guide Map on the desired surface.

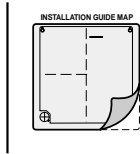

Make a hole with diameter of 6mm and depth of 30-35mm when piercing a screw point.

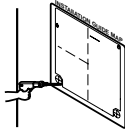

Drive the fore plastic anchors into drilled points.

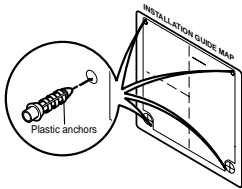

Hang the hole of product at the upper screws. (In this time, Remove the map) (Falling attention)

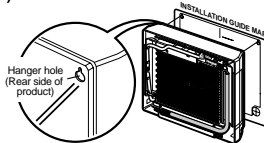

Check the fixed product with light power.

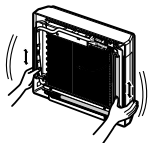

Adjust level even by level guage and fix to installation for reference on the well.

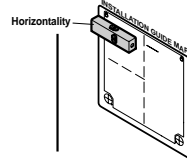

Drill the piercing part for connecting pipe as diameter 50mm. (In case of piercing rear surface)



Refer to No. 5 on this page when making a hole in the wall.

First, Drive the two points of the upper parts by screws (Leave 10mm for hanging product)

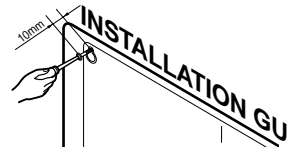

Drive the lower parts after facing the hole of product with plastic anchors, and fix completely the upper screws.

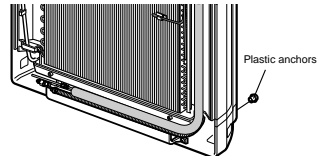

In case of nothing wrong in the matter, connect the pipe and the wire. (Installation manual reference)

**Drill a hole in the wall**

- Drill the piping hole with a  $\varnothing 70\text{mm}$  hole core drill. Drill the piping hole at either the right or the left with the hole slightly slanted to the outdoor side.

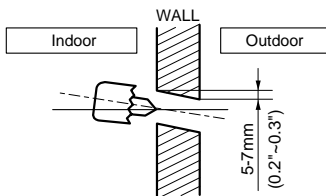

# Flaring Work and Connection of Piping

## Flaring work

Main cause for gas leakage is due to defect in flaring work. Carry out correct flaring work in the following procedure.

### Cut the pipes and the cable.

1. Use the piping kit accessory or the pipes purchased locally.
2. Measure the distance between the indoor and the outdoor unit.
3. Cut the pipes a little longer than measured distance.
4. Cut the cable 1.5m (5.0ft) longer than the pipe length.

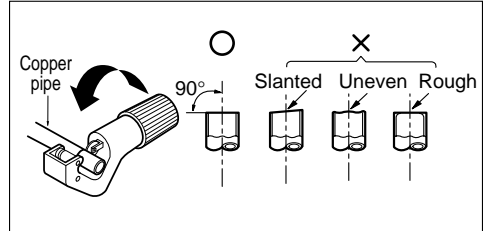

### Burrs removal

1. Completely remove all burrs from the cut cross section of pipe/tube.
2. Put the end of the copper tube/pipe in a downward direction as you remove burrs in order to avoid dropping burrs into the tubing.

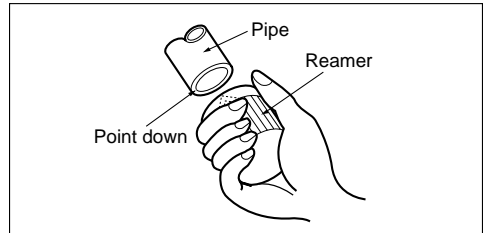

### Putting nut on

- Remove flare nuts attached to indoor and outdoor unit, then put them on pipe/tube having completed burr removal.  
(not possible to put them on after flaring work)

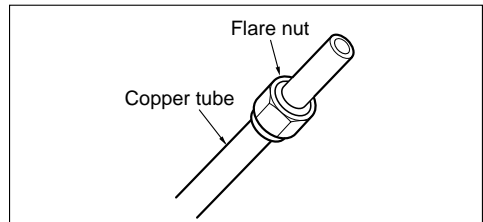

### Flaring work

- Carry out flaring work using flaring tool as shown below.
- Firmly hold copper pipe in a die in the dimension shown in the table above.

Outside diameter		A
mm	inch	mm
Ø6.35	1/4	1.1~1.3
Ø9.52	3/8	1.5~1.7

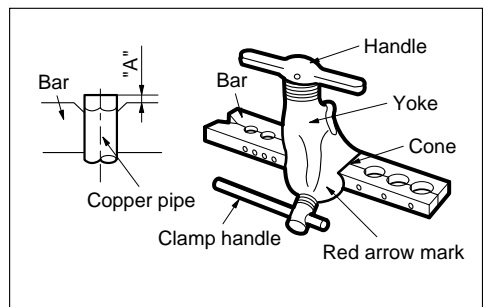

### Check

1. Compare the flared work with the figure by.
2. If a flared section is defective, cut it off and do flaring work again.

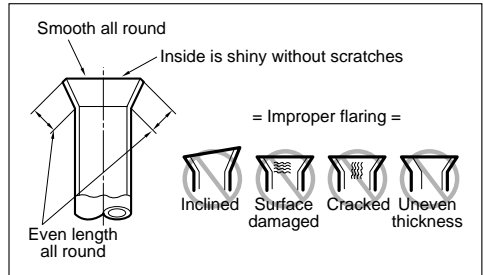

## Connecting the Piping

### Indoor

1. Prepare the indoor unit's piping and drain hose for installation through the wall.
2. Remove the plastic tubing retainer(see the illustration by) and pull the tubing and drain hose away from chassis.
3. Replace only the plastic tubing holder 1, not the holder 2 in the original position.

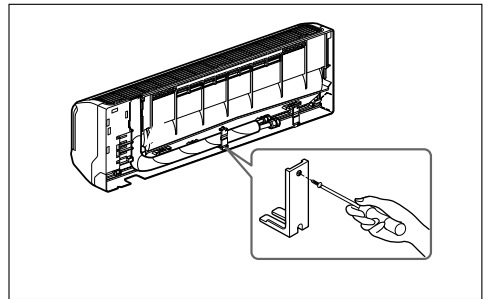

### For right rear piping

1. Route the indoor tubing and the drain hose in the direction of rear right.
2. Insert the connecting cable into the indoor unit from the outdoor unit through the piping hole.
  - Do not connect the cable to the indoor unit.
  - Make a small loop with the cable for easy connection later.
3. Tape the tubing, drain hose, and the connecting cable. Be sure that the drain hose is located at the lowest side of the bundle. Locating at the upper side can cause drain pan to overflow inside the unit.

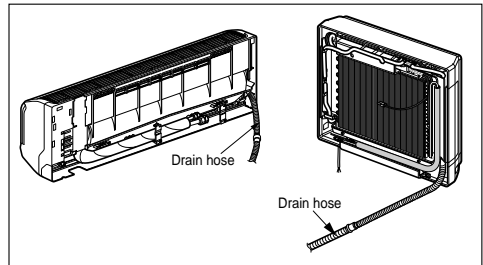

### ⚠ CAUTION

If the drain hose is routed inside the room, insulate the hose with an insulation material\* so that dripping from "sweating"(condensation) will not damage furniture or floors.

\*Foamed polyethylene or equivalent is recommended.

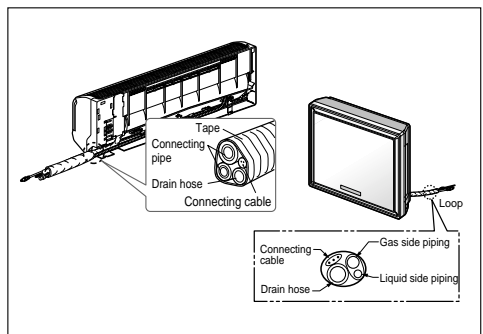

4. Indoor unit installation

Hook the indoor unit onto the upper portion of the installation plate.(Engage the two hooks of the rear top of the indoor unit with the upper edge of the installation plate.) Ensure that the hooks are properly seated on the installation plate by moving it left and right.

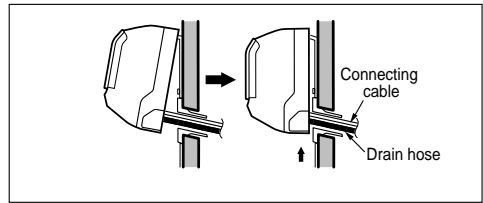

Press the lower left and right sides of the unit against the installation plate until the hooks engage into their slots(clicking sound).

**Connecting the piping to the indoor unit and drain hose to drain pipe.**

1. Align the center of the pipes and sufficiently tighten the flare nut by hand.
2. Tighten the flare nut with a wrench.

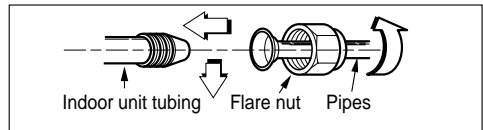

Outside diameter		Torque
mm	inch	kgf-m
Ø6.35	1/4	1.8~2.5
Ø9.52	3/8	3.4~4.2

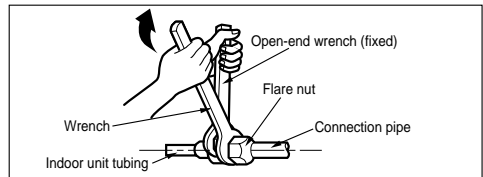

3. When extending the drain hose at the indoor unit, install the drain pipe.

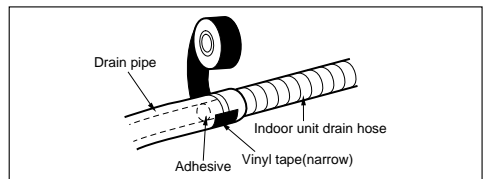

**Wrap the insulation material around the connecting portion.**

1. Overlap the connection pipe insulation material and the indoor unit pipe insulation material. Bind them together with vinyl tape so that there may be no gap.
2. Wrap the area which accommodates the rear piping housing section with vinyl tape.

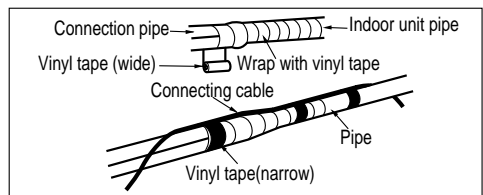
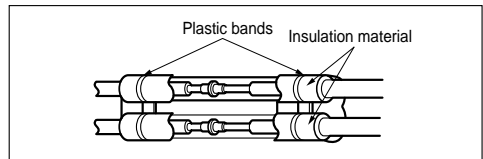

3. Bundle the piping and drain hose together by wrapping them with vinyl tape for enough to cover where they fit into the rear piping housing section.

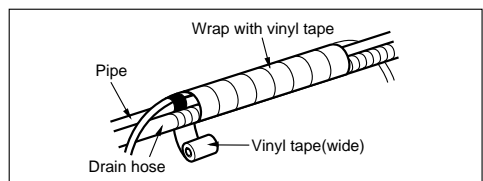

**For left rear piping**

1. Route the indoor tubing and the drain hose to the required piping hole position.
2. Insert the piping, drain hose, and the connecting cable into the piping hole.
3. Insert the connecting cable into the indoor unit.
  - Don't connect the cable to the indoor unit.
  - Make a small loop with the cable for easy connection later.
4. Tape the drain hose and the connecting cables.

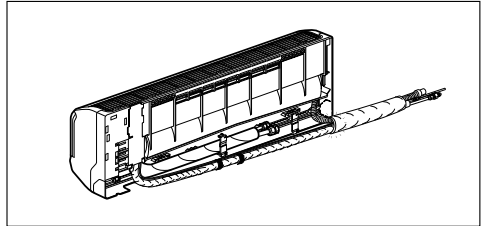
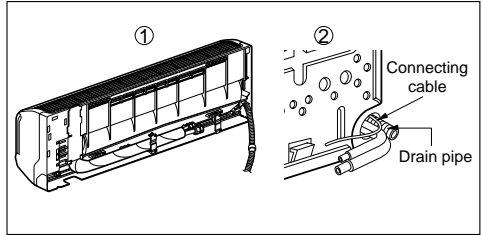

5. Indoor unit installation
  - Hang the indoor unit from the hooks at the top of the installation plate.
  - Insert the spacer etc. between the indoor unit and the installation plate and separate the bottom of the indoor unit from the wall.

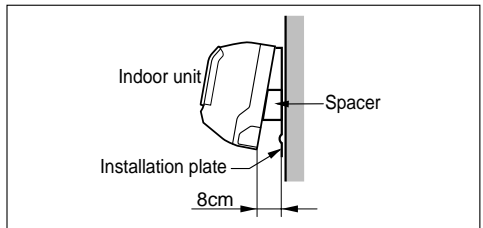

**Connecting the piping to the indoor unit and the drain hose to drain pipe.**

1. Align the center of the pipes and sufficiently tighten the flare nut by hand.

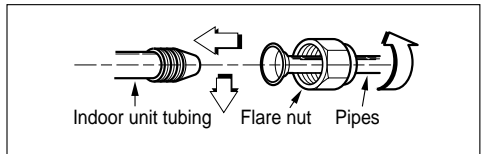

2. Tighten the flare nut with a wrench.

Outside diameter		Torque
mm	inch	kgf-m
Ø6.35	1/4	1.8~2..5
Ø9.52	3/8	3.4~4.2

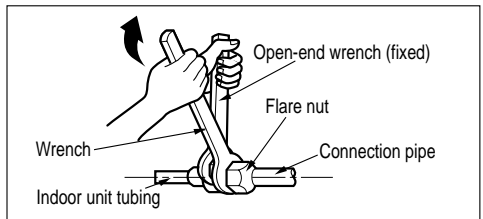

3. When extending the drain hose at the indoor unit, install the drain pipe.

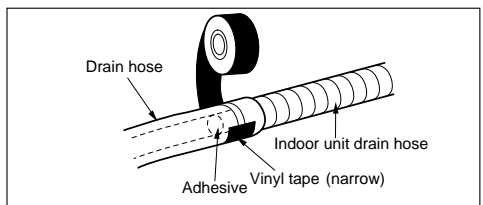

**Wrap the insulation material around the connecting portion.**

1. Overlap the connection pipe heat insulation and the indoor unit pipe heat insulation material. Bind them together with vinyl tape so that there may be no gap.
2. Wrap the area which accommodates the rear piping housing section with vinyl tape.

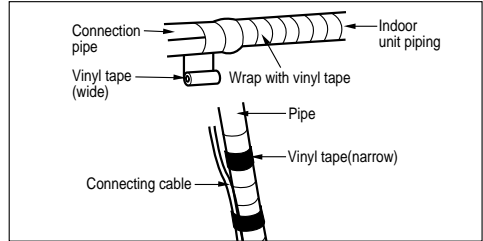
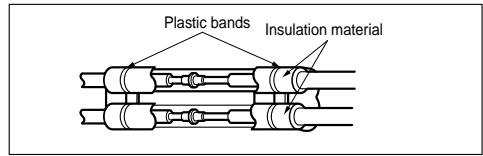

3. Bundle the piping and drain hose together by wrapping them with cloth tape over the range within which they fit into the rear piping housing section.

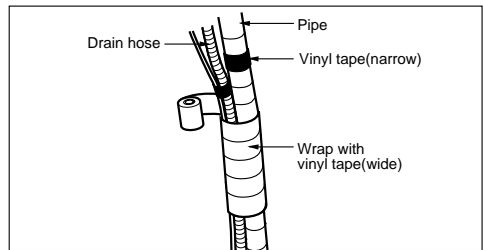

**Reroute the pipings and the drain hose across the back of the chassis.**

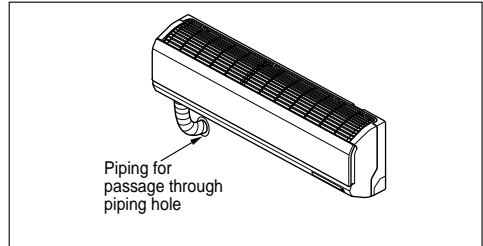

**Indoor unit installation**

1. Remove the spacer.
2. Ensure that the hooks are properly seated on the installation plate by moving it left and right.
3. Press the lower left and right sides of the unit against the installation plate until the hooks engage into their slots (clicking sound).

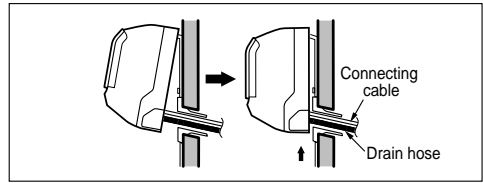

## ⚠ CAUTION

Installation Information. For left piping. Follow the instruction below.

### Good case

- Press on the upper side of clamp and unfold the tubing to downward slowly.

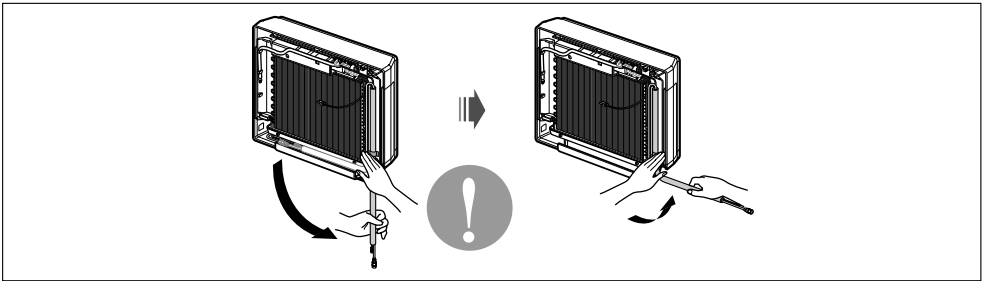
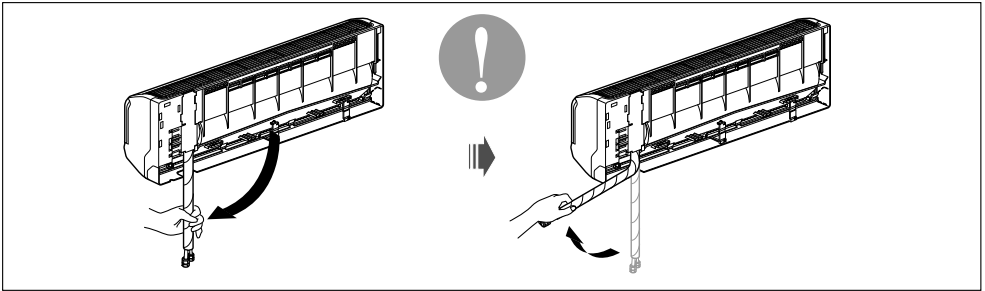

### Bad case

- Following bending type from right to left may cause damage to the tubing.

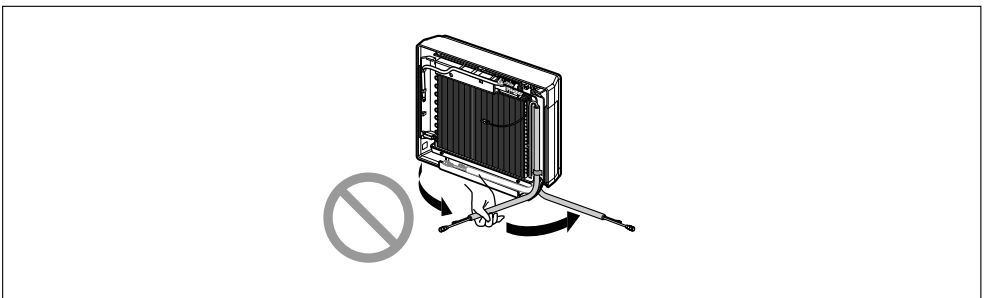
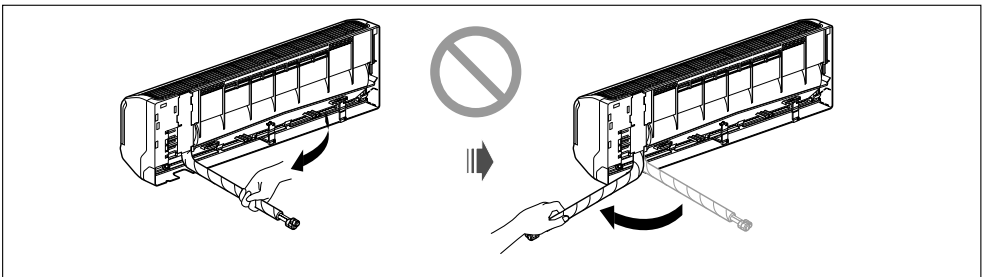

### Outdoor

Align the center of the pipings and sufficiently tighten the flare nut by hand.

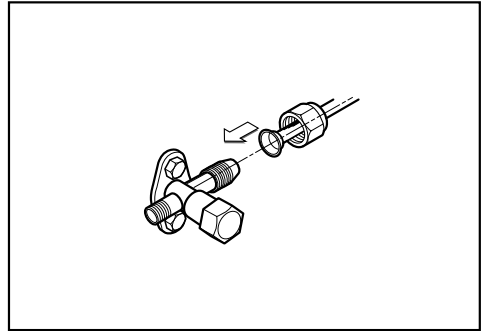

Finally, tighten the flare nut with torque wrench until the wrench clicks.

- When tightening the flare nut with torque wrench, ensure the direction for tightening follows the arrow on the wrench.

Outside diameter		Torque kgf·m
mm	inch	
Ø6.35	1/4	1.8~2.5
Ø9.52	3/8	3.4~4.2

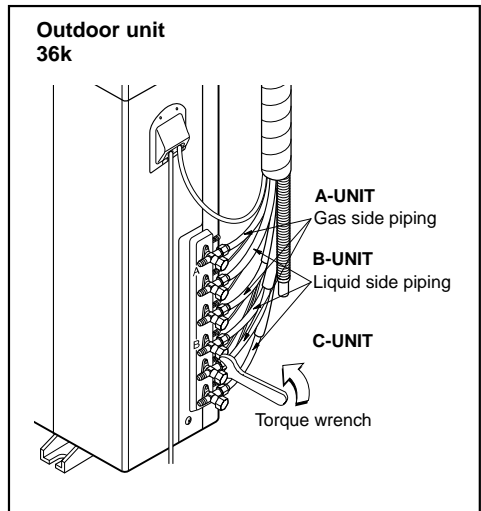
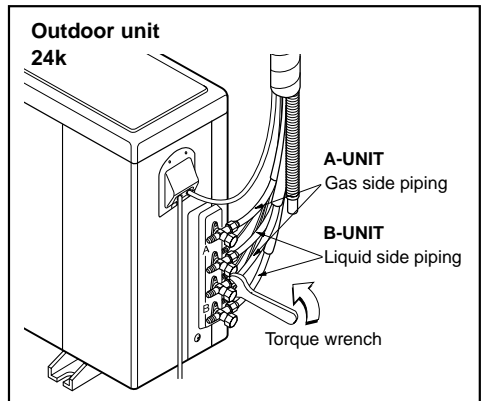

# Connecting the Cable between Indoor Unit and Outdoor Unit

## Connect the cable to the Indoor unit.

Connect the cable to the indoor unit by connecting the wires to the terminals on the control board individually according to the outdoor unit connection. (Ensure that the color of the wires of the outdoor unit and the terminal No. are the same as those of the indoor unit.)

The earth wire should be longer than the common wires.

The circuit diagram is not subject to change without notice.

When installing, refer to the electrical diagram behind the front panel of Indoor Unit.

The wiring for the outdoor unit can be found on the inside of the Outdoor Unit control cover.



### RECOMMEND:

- The circuit diagram is not subject to change without notice.
- Be sure to connect wires according to the wiring diagram.
- Connect the wires firmly, so that not to be pulled out easily.
- Connect the wires according to color codes by referring to the wiring diagram.



**RECOMMEND:** Provide a circuit breaker between power source and the outdoor unit as shown below.

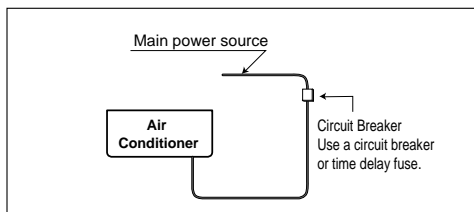

**RECOMMEND:** The power cord connected to the outdoor unit should be complied with the following specifications (ETL recognized and CSA certified).

24k

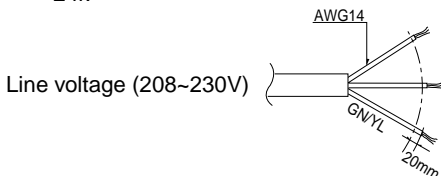

36k

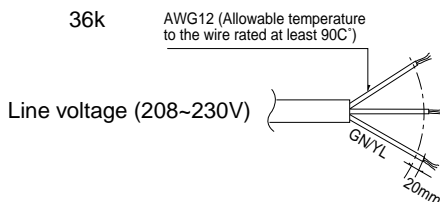

The power connecting cable connected to the indoor and outdoor unit should be complied with the following specifications (ETL recognized and CSA certified).

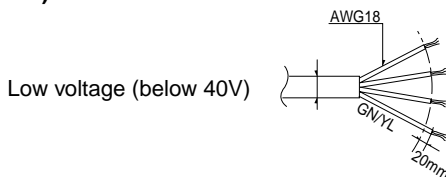

**RECOMMEND:** When using the separate wire as the power cord, please fix the separate wire into the control box panel by using tie wrap as the fixture.

## Connect the cable to the Outdoor unit.

1. Remove the cover control from the unit by loosening the screw.  
Connect the wires to the terminals on the control board individually as the following.
2. Secure the cable onto the control board with the holder (clamper).
3. Refix the cover control to the original position with the screw.

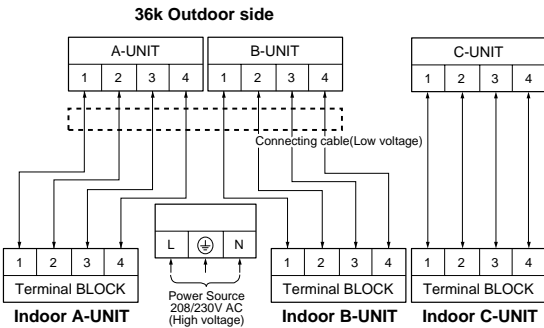
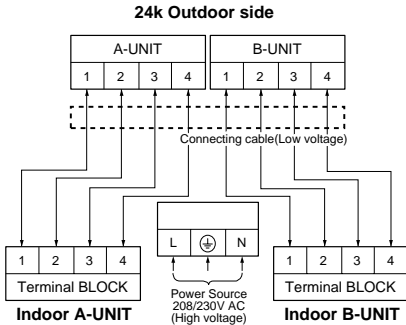
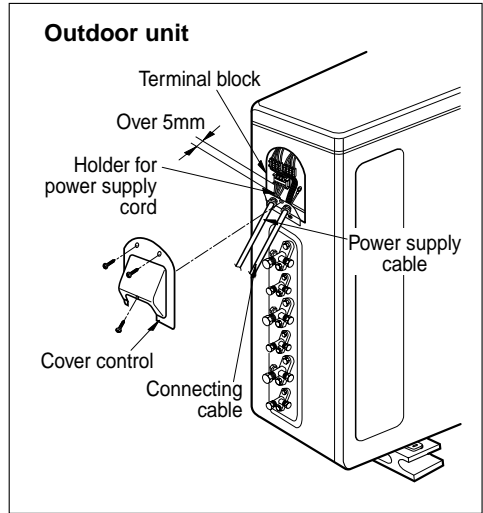

**NOTICE :**

1. Separately wire the high and low voltage line.
2. Use heat-proof electrical wiring capable of withstanding temperature up to 75°C(167°F).
3. Use outdoor and waterproof connection cable rated more than 300V for the connection between indoor and outdoor unit. (For example, Type SJO-WA)



**WARNING:**

- Be sure to comply with local codes while running the wire from the indoor unit to the outdoor unit(size of wire and wiring method, etc).
- Every wire must be connected firmly.
- No wire should be allowed to touch refrigerant tubing, the compressor or any moving parts.

## Connection method of the connecting cable(Example)

- (1) Remove two-caps on the conduit panel.
- (2) Make a hole appropriate for the passage of connection cable through on cap by tool.  
(for low voltage line)
- (3) Pass the connecting cable through the hole.
- (4) Properly connect the cable on the terminal block.
- (5) Fix the connection cable with cord clamp provided on the unit not to have strain at the terminal when the connection cable is pulled outside up to a 35 pound weight.
- (6) Wind the vinyl tape round the connecting cable for sealing between the surface of the connection cable and cap.
- (7) Finally, Fix the cap to the conduit panel.

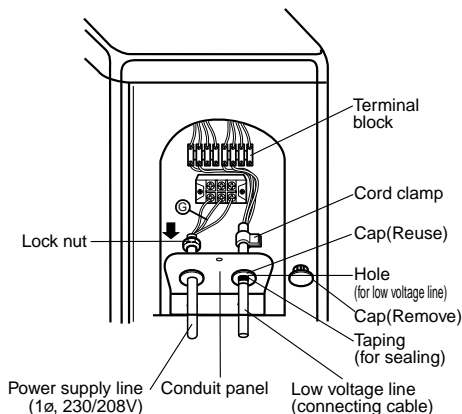

**⚠ WARNING: Loose wiring may cause the terminal to overheat or result in unit malfunction. A fire hazard may also exist. Therefore, be sure all wiring is tightly connected.**

When connecting each power wire to the corresponding terminal, follow instructions "How to connect wiring to the terminals" and fasten the wire tightly with the fixing screw of the terminal plate.

### How to connect wiring to the terminals

For strand wiring

- (1) Cut the wire end with a wire cutter or wire-cutting pliers, then strip the insulation to expose the strand wiring about 10mm(3/8").
- (2) Using a screwdriver, remove the terminal screw(s) on the terminal plate.
- (3) Using a round terminal fastener or pliers, securely clamp each stripped wire end with a round terminal.
- (4) Position the round terminal wire, and replace and tighten the terminal screw using a screwdriver.

#### High voltage

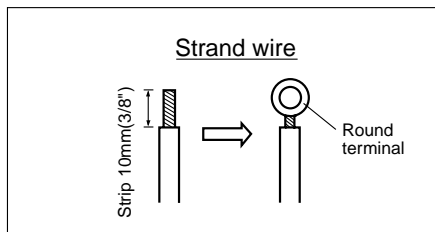

#### Low voltage

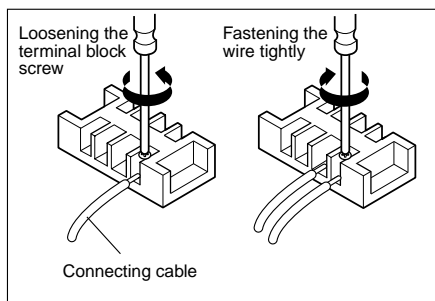



**CAUTION: Provide a circuit breaker between power source and the unit as shown below.**

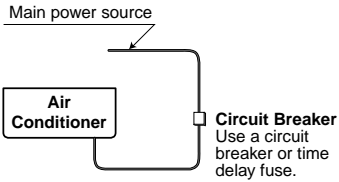

Model	Power source	Fuse or breaker Capacity
24k	1 $\phi$ ,230/208V	25A
36k	1 $\phi$ ,230/208V	40A

## Connect the cable to the indoor unit

1. Connect the wires to the terminals on the control board individually according to the outdoor unit connection.
  - Ensure that the color of the wires of outdoor unit and the terminal No. are the same as those of indoor unit respectively.

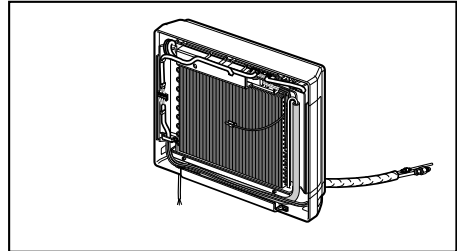
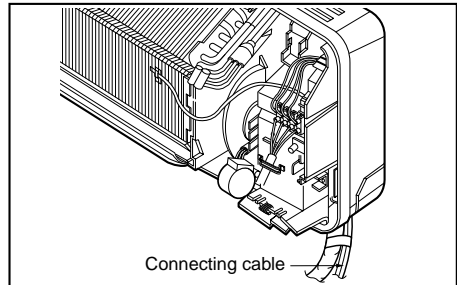

2. Attach the Grille onto the cabinet.
  - Grasp the lower left and right side of the Grille and engage four tabs on the top inside edge of the chassis.
  - Press the Grille toward the chassis until it will be back into place.

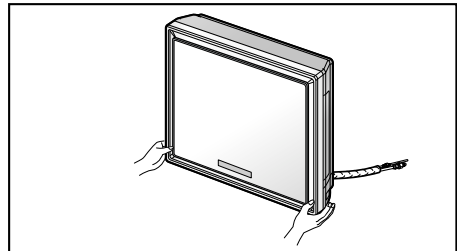
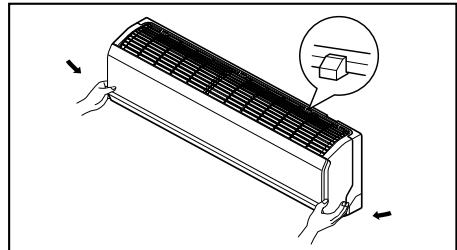

# Checking the Drainage, Forming the Pipings and Long Pipe Setting

## Checking the drainage

### To check the drainage.

1. Pour a glass of water on the evaporator.
2. Ensure the water flows through the drain hose of the indoor unit without any leakage and goes out the drain exit.

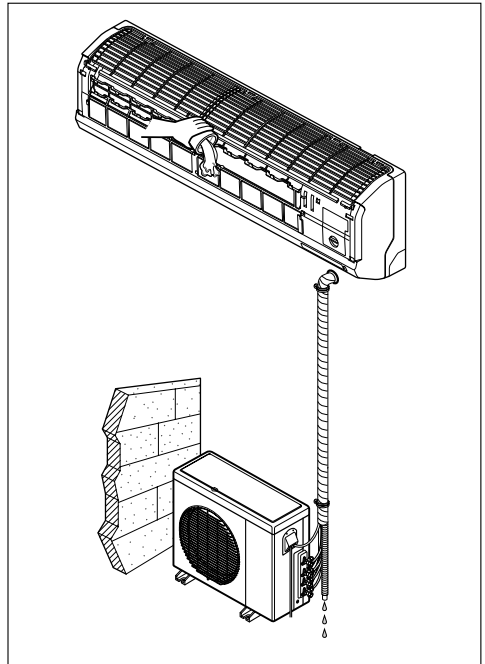

### Drain piping

1. The drain hose should point downward for easy drain flow.

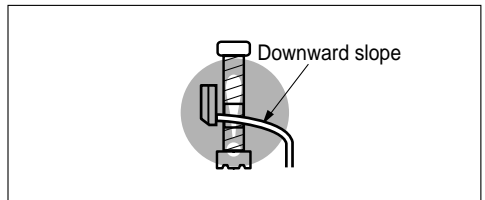

2. Do not make drain piping.

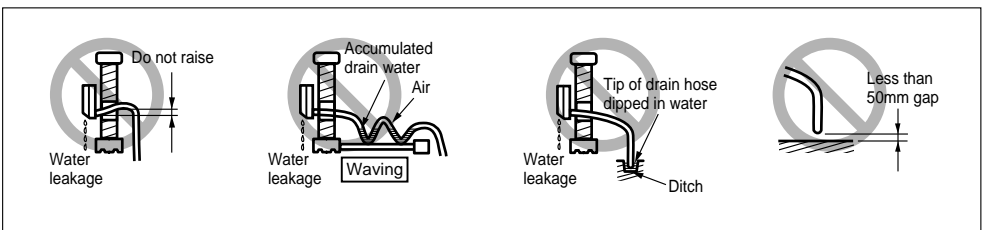

## Forming the piping

**Form the piping by wrapping the connecting portion of the indoor unit with insulation material and secure it with two kinds of vinyl tape.**

- If you want to connect an additional drain hose, the end of the drain outlet should be routed above the ground. Secure the drain hose appropriately.

**In cases where the outdoor unit is installed below the indoor unit perform the following.**

1. Tape the piping, drain hose and connecting cable from down to up.
2. Secure the tapped piping along the exterior wall using saddle or equivalent.

**In cases where the Outdoor unit is installed above the Indoor unit perform the following.**

1. Tape the piping and connecting cable from down to up.
2. Secure the taped piping along the exterior wall. Form a trap to prevent water entering the room.
3. Fix the piping onto the wall by saddle or equivalent.

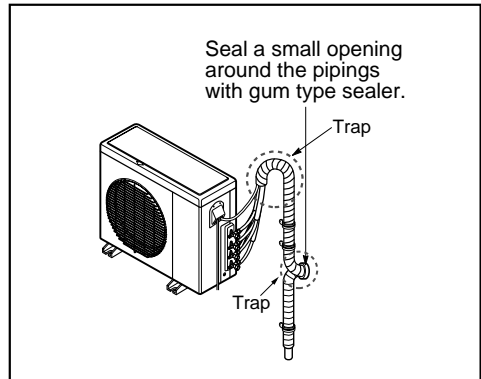
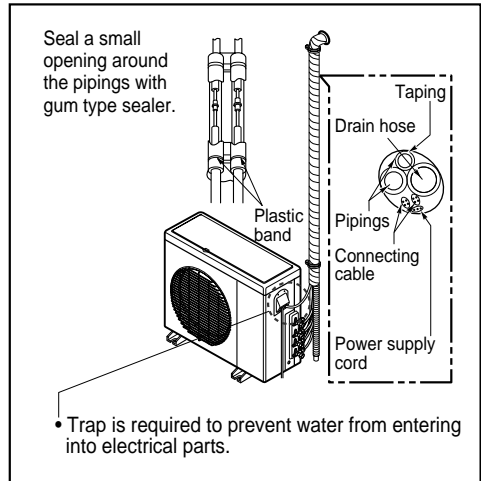

# Air Purging and Evacuation

Air and moisture remaining in the refrigerant system have undesirable effects as indicated below.

1. Pressure in the system rises.
  2. Operating current rises.
  3. Cooling(or heating) efficiency drops.
  4. Moisture in the refrigerant circuit may freeze and block capillary tubing.
  5. Water may lead to corrosion of parts in the refrigeration system.
- Therefore, the indoor/outdoor unit and connecting tube must be checked for leak tight, and vacuumed to remove incondensable gas and moisture in the system.

## Checking method

### Preparation

- Check that each tube(both liquid and gas side tubes) between the indoor and outdoor units have been properly connected and all wiring for the test run has been completed. Remove the service valve caps from both the gas and the liquid side on the outdoor unit. Check that both the liquid and the gas side service valves on the outdoor unit are kept closed at this stage.

### Leakage test

- Connect the manifold valve(with pressure gauges) and dry nitrogen gas cylinder to this service port with charge hoses.

**CAUTION:** Be sure to use a manifold valve for leak testing. The high side manifold valve must always be kept closed.

- Pressurize the system to no more than 150 P.S.I.G. with dry nitrogen gas and close the cylinder valve when the gauge reading reached 150 P.S.I.G. Next, test for leaks with liquid soap.

**CAUTION:** To avoid nitrogen entering the refrigerant system in a liquid state, the top of the cylinder must be higher than its bottom when you pressurize the system. Usually, the cylinder is used in a vertical standing position.

**NOTICE :** Leakage test should be done for each indoor unit connection set, separately.

1. Do a leakage test of all joints of the tubing(both indoor and outdoor) and both gas and liquid side service valves. Bubbles indicate a leak. Be sure to wipe off the soap with a clean cloth.
2. After the system is found to be free of leaks, relieve the nitrogen pressure by loosening the charge hose connector at the nitrogen cylinder. When the system pressure is reduced to normal, disconnect the hose from the cylinder.

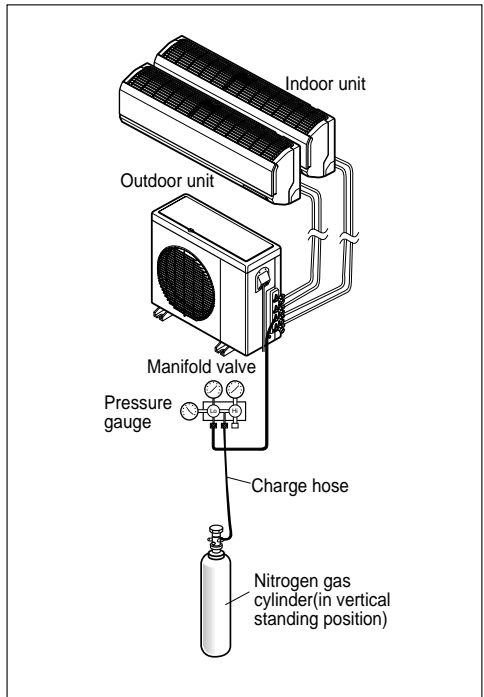

## Evacuation

1. Connect the charge hose end described in the preceding steps to the vacuum pump to evacuate the tubing and indoor unit. Confirm the "Lo" knob of the manifold valve is open. Then, run the vacuum pump. The operation time for evacuation varies with tubing length and capacity of the pump.

[Each Room] The vacuum pump must be operated less than 0.8torr of the gage pressure.

2. When the desired vacuum is reached, close the "Lo" knob of the manifold valve and stop the vacuum pump.

### Finishing the job

1. With a service valve wrench, turn the valve stem of liquid side valve counter-clockwise to fully open the valve.
2. Turn the valve stem of gas side valve counter-clockwise to fully open the valve.
3. Loosen the charge hose connected to the gas side service port slightly to release the pressure, then remove the hose.
4. Replace the flare nut and its bonnet on the gas side service port and fasten the flare nut securely with an adjustable wrench. This process is very important to prevent leakage from the system.
5. Replace the valve caps at both gas and liquid side service valves and fasten them tight.

This completes air purging with a vacuum pump.

The air conditioner is now ready for test running.

### NOTICE

: Repeat evacuation procedure for each indoor unit.

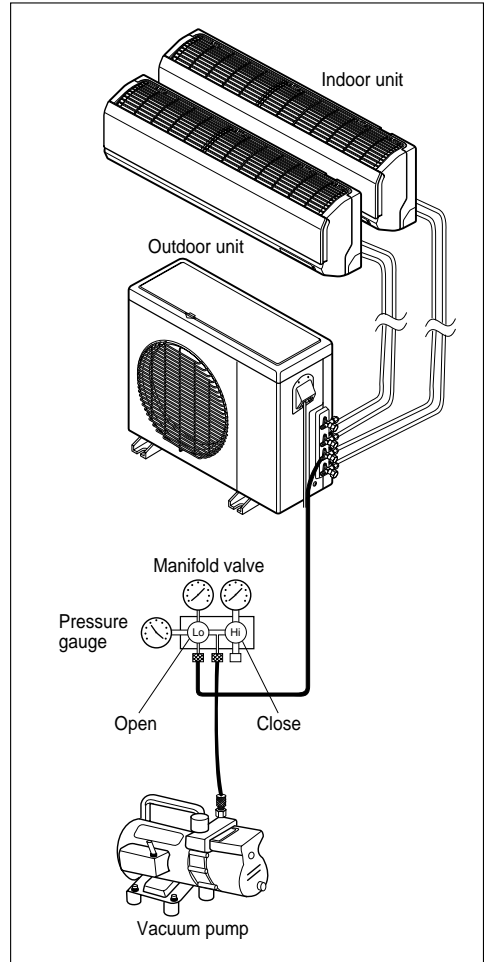

# Charging

- Each outdoor unit is factory charged (nameplate charge) for the evaporator as well as a 7.5m(25ft) line set for each indoor line.  
Any time total line set is used either shorter or longer than the nominal 22.5m(75ft: for tri-zone) line set length the refrigerant charge has to be adjusted.
- Whether the line set is made shorter or longer you must adjust the charge based on how many ft of tubing are either added or removed based on 20g(0.22oz) of R-410A per meter(foot).

Capacity (Btu/h)	Max total length of all pipes (A+B+C)	Max length of each pipe (A/B/C)	Min length of each pipe (A/B/C)	Max Elevation between each indoor unit and outdoor unit (h1)	Max elevation between indoor units (h2)	Additional Refrigerant
24k	30m(100ft)	15m(50ft)	3m(10ft)	7.5m(25ft)	7.5m(25ft)	20g/m(0.22oz/ft)
36k	45m(150ft)	15m(50ft)	3m(10ft)	7.5m(25ft)	7.5m(25ft)	20g/m(0.22oz/ft)

**Example:** A 80ft line set is used for tri - zone 5 additional ft X 0.22 ounces per foot= add 1.1 ounces of R-410A

## Important:

If you are ever uncertain of the unit charge, reclaim, evacuate and weigh in the correct charge using the unit nameplate charge adjusting for line sets longer or shorter than 7.5m(25ft) for each indoor unit.

# Panel Front Assembly (Artcool type Only)

1. First, Check the side cover assembly exactly, Fix power cord in the bottom groove of cover side left.

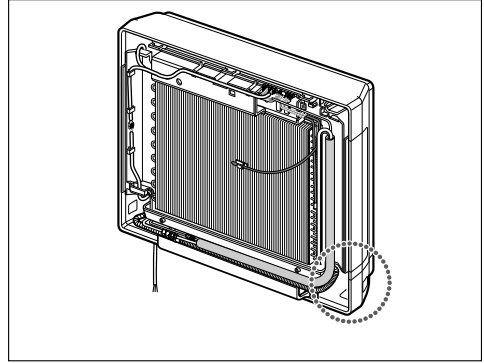

2. Assemble connecting lead wire with controller and first fix the upper part of panel front, then match the lower part of panel front

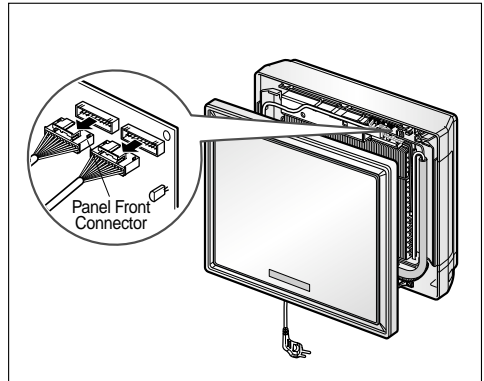

3. Suspend hook of front panel in the groove after contract lower of 2 screws.

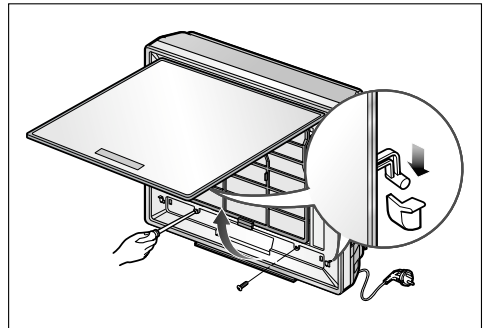

# Test Running

1. Check that all tubing and wiring have been properly connected.
2. Check that the gas and liquid side service valves are fully open.

## Prepare remote control

Remove the battery cover by pulling it according to the arrow direction.

Insert new batteries making sure that the (+) and (-) of battery are installed correctly.

Reattach the cover by pushing it back into position.

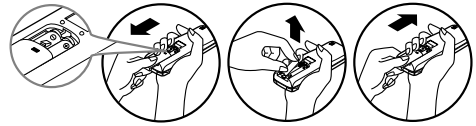

### NOTICE :

- Use 2 AAA(1.5volt) batteries. Do not use rechargeable batteries.
- Remove the batteries from the remote control if the system is not going to be used for a long time.

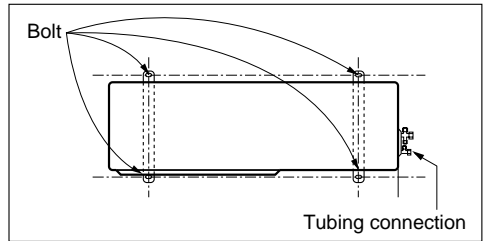

## Evaluation of the performance

Operate all indoor units for 15~20 minutes, then check the system refrigerant charge:

1. Measure the pressure of one of the gas side service valves.
2. Measure the temperature of the intake and discharge of air.
3. Ensure the difference between the intake temperature and the discharge is more than 8°C(14.4°F).
4. For reference, the gas side pressure of optimum condition is as below.(Cooling)

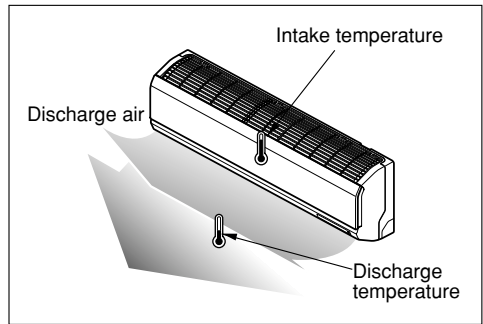

Refrigerant	Outside ambient TEMP.	The pressure of the gas side service valve.
R-410A	35°C (95°F)	8.5~9.5kg/cm <sup>2</sup> G(120~135 P.S.I.G.)

**NOTICE :** If the actual pressure are higher than shown, the system is most likely over-charged, and charge should be removed. If the actual pressure are lower than shown, the system is most likely undercharged, and charge should be added.

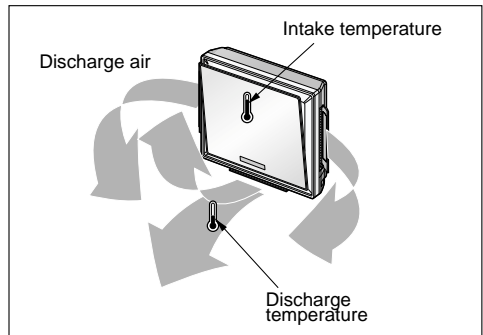

### Important:

- ❑ Individual zones should be all in the same operation mode (Heating or Cooling mode)

# Combination indoor units

The indoor units connectable to the outdoor unit are shown below.

Type	Chassis Name	Model Name	
		Capacity, Btu/h	
		9000	12000
Standard Type	S4		
Standard Type/ Artcool Mirror Type	SE		
Artcool Type	SP3		

- NOTICE** :
1. The total capacity(in Btu/h unit) of connected indoor unit models represents the total sum of the figures expressed in the indoor model name.
  2. Combinations in which the total capacity of the connected indoor units exceeds the capacity of the outdoor unit will reduce the capacity of each indoor unit below the rated capacity during simultaneous operation. Therefore, if circumstances allows, combine indoor units within the capacity of the outdoor unit

# Combination table of Models

✳ This table shows available combination.

Above standard combination, suitable performance may not be obtained depending on operating condition.

## 24k (2 rooms)

	Combination		
	Unit-A	Unit-B	Total
1 UNIT	9		9
	12		12
2 UNIT	9	9	18
	9	12	21
	12	12	24

## 36k (3 rooms)

	Combination			
	Unit-A	Unit-B	Unit-C	Total
1 UNIT	9			9
	12			12
2 UNIT	9	9		18
	9	12		21
	12	12		24
3 UNIT	9	9	9	27
	9	9	12	30
	9	12	12	33
	12	12	12	36