



website <http://www.lgservice.com>

LG

# **MULTI V™ PLUS System**

## Outdoor Unit **R410A**

### **INSTALLATION MANUAL**

**MODELS: ARUV Series  
ARUN Series**

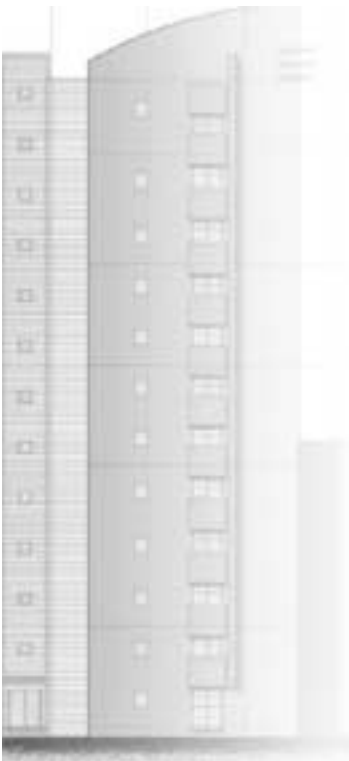

#### **IMPORTANT**

- Please read this installation manual completely before installing the product.
- Installation work must be performed in accordance with the national wiring standards by authorized personnel only.
- Please retain this installation manual for future reference after reading it thoroughly.

ENGLISH

ITALIANO

ESPAÑOL

FRANÇAIS

DEUTSCH

PORTUGUESE

# TABLE OF CONTENTS

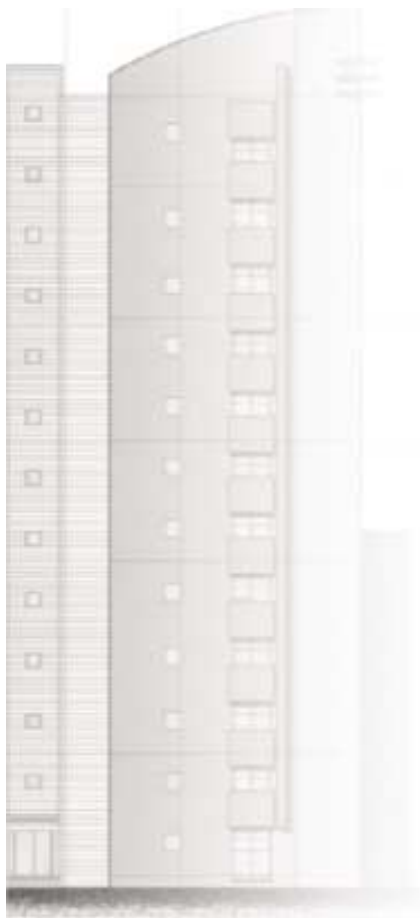

Safety Precautions.....	3
Installation Process .....	10
Outdoor units Information .....	11
Environment-friendly Alternative Refrigerant R410A .....	15
Select the Best Location .....	15
Installation Space .....	16
Lifting method .....	20
Installation .....	21
Refrigerant piping installation.....	26
Electrical Wiring.....	46
Test Run.....	72
Caution For Refrigerant Leak .....	80

# Safety Precautions



To prevent injury to the user or other people and property damage, the following instructions must be followed.

- Incorrect operation due to ignoring instruction will cause harm or damage. The seriousness is classified by the following indications.

**⚠ WARNING** This symbol indicates the possibility of death or serious injury.

**⚠ CAUTION** This symbol indicates the possibility of injury or damage to properties only.

- Meanings of symbols used in this manual are as shown below.

	<b>Be sure not to do.</b>
	<b>Be sure to follow the instruction.</b>

## ⚠ WARNING

### ■ Installation

Have all electric work done by a licensed electrician according to "Electric Facility Engineering Standard" and "Interior Wire Regulations" and the instructions given in this manual and always use a special circuit.

- If the power source capacity is inadequate or electric work is performed improperly, electric shock or fire may result.



Ask the dealer or an authorized technician to install the air conditioner.

- Improper installation by the user may result in water leakage, electric shock, or fire.



**Always ground the product.**

- There is risk of fire or electric shock.



**Always install a dedicated circuit and breaker.**

- Improper wiring or installation may cause fire or electric shock.



## Safety Precautions

**For re-installation of the installed product, always contact a dealer or an Authorized Service Center.**

- There is risk of fire, electric shock, explosion, or injury.



**Do not install, remove, or re-install the unit by yourself (customer).**

- There is risk of fire, electric shock, explosion, or injury.



**Do not store or use flammable gas or combustibles near the air conditioner.**

- There is risk of fire or failure of product.



**Use the correctly rated breaker or fuse.**

- There is risk of fire or electric shock.

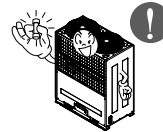

**Prepare for strong wind or earthquake and install the unit at the specified place.**

- Improper installation may cause the unit to topple and result in injury.



**Do not install the product on a defective installation stand.**

- It may cause injury, accident, or damage to the product.

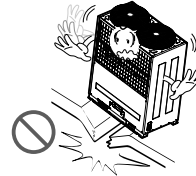

**When installing and moving the air conditioner to another site, do not charge it with a different refrigerant from the refrigerant specified on the unit.**

- If a different refrigerant or air is mixed with the original refrigerant, the refrigerant cycle may malfunction and the unit may be damaged.



**Do not reconstruct to change the settings of the protection devices.**

- If the pressure switch, thermal switch, or other protection device is shorted and operated forcibly, or parts other than those specified by LGE are used, fire or explosion may result.

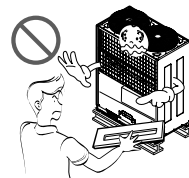

**Ventilate before operating air conditioner when gas leaked out.**

- It may cause explosion, fire, and burn.



**Securely install the cover of control box and the panel.**

- If the cover and panel are not installed securely, dust or water may enter the outdoor unit and fire or electric shock may result.

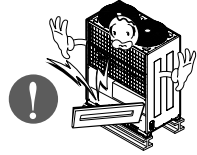

**If the air conditioner is installed in a small room, measures must be taken to prevent the refrigerant concentration from exceeding the safety limit when the refrigerant leaks.**

- Consult the dealer regarding the appropriate measures to prevent the safety limit from being exceeded. Should the refrigerant leak and cause the safety limit to be exceeded, hazards due to lack of oxygen in the room could result.



**■ Operation**

**Do not damage or use an unspecified power cord.**

- There is risk of fire, electric shock, explosion, or injury.



**Use a dedicated outlet for this appliance.**

- There is risk of fire or electrical shock.

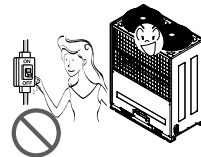

**Be cautious that water could not enter the product.**

- There is risk of fire, electric shock, or product damage.

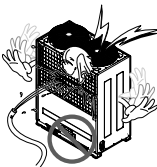

**Do not touch the power switch with wet hands.**

- There is risk of fire, electric shock, explosion, or injury.

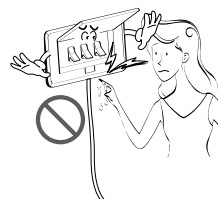

## Safety Precautions

When the product is soaked (flooded or submerged), contact an Authorized Service Center.

- There is risk of fire or electric shock.



Be cautious not to touch the sharp edges when installing.

- It may cause injury.



Take care to ensure that nobody could step on or fall onto the outdoor unit.

- This could result in personal injury and product damage.

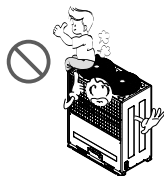

Do not open the inlet grille of the product during operation. (Do not touch the electrostatic filter, if the unit is so equipped.)

- There is risk of physical injury, electric shock, or product failure.

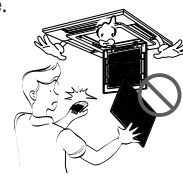

## CAUTION

### Installation

Always check for gas (refrigerant) leakage after installation or repair of product.

- Low refrigerant levels may cause failure of product.

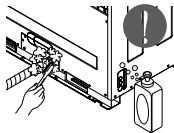

Do not install the product where the noise or hot air from the outdoor unit could damage the neighborhoods.

- It may cause a problem for your neighbors.



Keep level even when installing the product.

- To avoid vibration or water leakage.

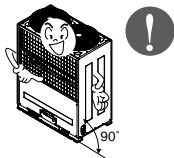

Do not install the unit where combustible gas may leak.

- If the gas leaks and accumulates around the unit, an explosion may result.



**Use power cables of sufficient current carrying capacity and rating.**

- Cables that are too small may leak, generate heat, and cause a fire.

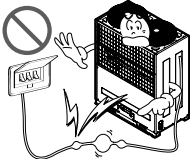

**Do not use the product for special purposes, such as preserving foods, works of art, etc. It is a consumer air conditioner, not a precision refrigeration system.**

- There is risk of damage or loss of property.

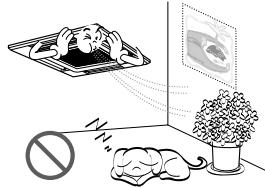

**Keep the unit away from children. The heat exchanger is very sharp.**

- It can cause the injury, such as cutting the finger. Also the damaged fin may result in degradation of capacity.



**When installing the unit in a hospital, communication station, or similar place, provide sufficient protection against noise.**

- The inverter equipment, private power generator, high-frequency medical equipment, or radio communication equipment may cause the air conditioner to operate erroneously, or fail to operate. On the other hand, the air conditioner may affect such equipment by creating noise that disturbs medical treatment or image broadcasting.



**Do not install the product where it is exposed to sea wind (salt spray) directly.**

- It may cause corrosion on the product. Corrosion, particularly on the condenser and evaporator fins, could cause product malfunction or inefficient operation.



■ Operation

**Do not use the air conditioner in special environments.**

- Oil, steam, sulfuric smoke, etc. can significantly reduce the performance of the air conditioner or damage its parts.

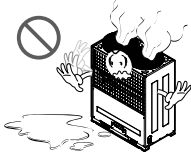

**Do not block the inlet or outlet.**

- It may cause failure of appliance or accident.

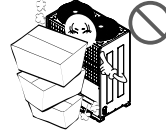

**Make the connections securely so that the outside force of the cable may not be applied to the terminals.**

- Inadequate connection and fastening may generate heat and cause a fire.



**Be sure the installation area does not deteriorate with age.**

- If the base collapses, the air conditioner could fall with it, causing property damage, product failure, or personal injury.



**Install and insulate the drain hose to ensure that water is drained away properly based on the installation manual.**

- A bad connection may cause water leakage.



**Be very careful about product transportation.**

- Only one person should not carry the product if it weighs more than 20 kg.
- Some products use PP bands for packaging. Do not use any PP bands for a means of transportation. It is dangerous.
- Do not touch the heat exchanger fins. Doing so may cut your fingers.
- When transporting the outdoor unit, suspending it at the specified positions on the unit base. Also support the outdoor unit at four points so that it cannot slip sideways.

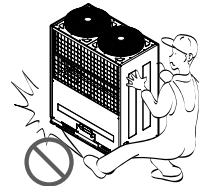

**Safely dispose of the packing materials.**

- Packing materials, such as nails and other metal or wooden parts, may cause stabs or other injuries.
- Tear apart and throw away plastic packaging bags so that children may not play with them. If children play with a plastic bag which was not torn apart, they face the risk of suffocation.



**Do not touch any of the refrigerant piping during and after operation.**

- It can cause a burn or frostbite.

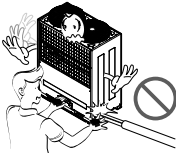

**Do not directly turn off the main power switch after stopping operation.**

- Wait at least 5 minutes before turning off the main power switch. Otherwise it may result in water leakage or other problems.

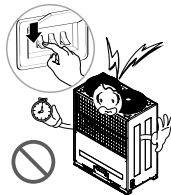

**Use a firm stool or ladder when cleaning or maintaining the air conditioner.**

- Be careful and avoid personal injury.

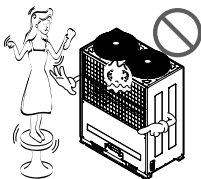

**Turn on the power at least 6 hours before starting operation.**

- Starting operation immediately after turning on the main power switch can result in severe damage to internal parts. Keep the power switch turned on during the operational season.

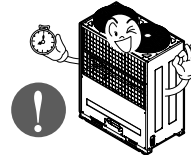

**Do not operate the air conditioner with the panels or guards removed.**

- Rotating, hot, or high-voltage parts can cause injuries.



**Auto-addressing should be done in condition of connecting the power of all indoor and outdoor units. Auto-addressing should also be done in case of changing the indoor unit PCB.**



**Do not insert hands or other objects through the air inlet or outlet while the air conditioner is plugged in.**

- There are sharp and moving parts that could cause personal injury.



# Installation Process

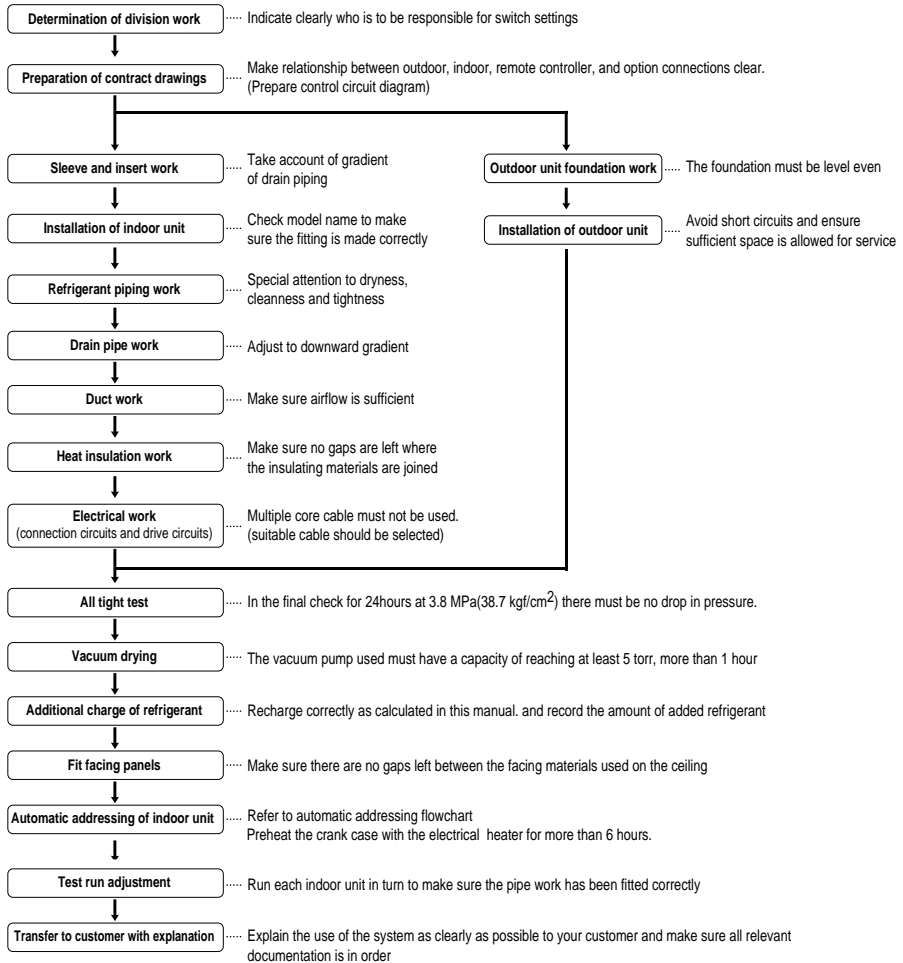

## ⚠ CAUTION

- The above list indicates the order in which the individual work operations are normally carried out but this order may be varied where local conditions warrants such change.
- The wall thickness of the piping should comply with the relevant local and national regulations for the designed pressure 3.8MPa.
- Since R410A is a mixed refrigerant, the required additional refrigerant must be charged in its liquid state.(If the refrigerant is charged in its gaseous state, its composition changes and the system will not work properly.)

# Outdoor units Information



**CAUTION:** A ratio of the connectable Indoor Units with the Outdoor: Within 50 ~ 130%  
A ratio of the running Indoor Units with the Outdoor: Within 10 ~ 100%  
130% combination ratio is a reduction in capacity in defrost

## Power Supply: Outdoor Unit (3Ø, 380 ~ 415V, 50Hz)

### ■ Cooling Only

Unit System(HP)		1 Outdoor Unit(Half size)			1 Outdoor Unit		
		5	6	8	10	12	14
Model		ARUV508T1	ARUV608T1	ARUV808T1	ARUV1008T1	ARUV1208T1	ARUV1408T1
Product Charge	kg	6	6	6	8	8	8
CF(Correction Factor)	kg	-1	-1	0	0	1	2
Max. Connectable No. of Indoor Units		6	8	13	16	20	20
Net Weight	kg	150	150	150	300	300	300
	lbs	330.7	330.7	330.7	661.4	661.4	661.4
Dimensions (W*H*D)	mm	806 * 1607 * 730	806 * 1607 * 730	806 * 1607 * 730	1280 * 1607 * 730	1280 * 1607 * 730	1280 * 1607 * 730
	inch	31.7 * 63.3 * 28.74	31.7 * 63.3 * 28.74	31.7 * 63.3 * 28.74	50.4 * 63.3 * 28.74	50.4 * 63.3 * 28.74	50.4 * 63.3 * 28.74
Connecting Pipes	Liquid Pipes[mm(inch)]	Ø9.52(3/8)	Ø9.52(3/8)	Ø9.52(3/8)	Ø9.52(3/8)	Ø12.7(1/2)	Ø12.7(1/2)
	Gas Pipes[mm(inch)]	Ø15.88(5/8)	Ø19.05(3/4)	Ø19.05(3/4)	Ø22.2(7/8)	Ø28.58(1 1/8)	Ø28.58(1 1/8)

Unit System(HP)		2 Outdoor Units					3 Outdoor Units
		16	18	20	22	24	26
Model		ARUV1608T1	ARUV1808T1	ARUV2008T1	ARUV2208T1	ARUV2408T1	ARUV2608T1
		ARUV808T1	ARUV1008T1	ARUV1008T1	ARUV1208T1	ARUV1208T1	ARUV1008T1
		ARUC808T1	ARUC808T1	ARUC1008T1	ARUC1008T1	ARUC1208T1	ARUC808T1
							ARUC808T1
Product Charge	kg	16	16	16	16	16	24
CF(Correction Factor)	kg	-2	-1	0	1	2	-2
Max. Connectable No. of Indoor Units		20	20	20	22	24	32
Net Weight	kg	300x2	300x2	300x2	300x2	300x2	300x3
	lbs	661.4x2	661.4x2	661.4x2	661.4x2	661.4x2	661.4x3
Dimensions (W*H*D)	inch	(1280 * 1607 * 730)x2	(1280 * 1607 * 730)x2	(1280 * 1607 * 730)x2	(1280 * 1607 * 730)x2	(1280 * 1607 * 730)x2	(1280 * 1607 * 730)x3
	mm	(50.4 * 63.3 * 28.74)x2	(50.4 * 63.3 * 28.74)x2	(50.4 * 63.3 * 28.74)x2	(50.4 * 63.3 * 28.74)x2	(50.4 * 63.3 * 28.74)x2	(50.4 * 63.3 * 28.74)x3
Connecting Pipes	Liquid Pipes[mm(inch)]	Ø12.7(1/2)	Ø15.88(5/8)	Ø15.88(5/8)	Ø15.88(5/8)	Ø15.88(5/8)	Ø19.05(3/4)
	Gas Pipes[mm(inch)]	Ø28.58(1 1/8)	Ø28.58(1 1/8)	Ø28.58(1 1/8)	Ø28.58(1 1/8)	Ø34.9(1 3/8)	Ø34.9(1 3/8)

Unit System(HP)		3 Outdoor Units						
		28	30	32	34	36	38	40
Model		ARUV2808T1	ARUV3008T1	ARUV3208T1	ARUV3408T1	ARUV3608T1	ARUV3808T1	ARUV4008T1
		ARUV1008T1	ARUV1008T1	ARUV1208T1	ARUV1208T1	ARUV1208T1	ARUV1408T1	ARUV1408T1
		ARUC1008T1	ARUC1008T1	ARUC1008T1	ARUC1208T1	ARUC1208T1	ARUC1208T1	ARUC1408T1
		ARUC808T1	ARUC1008T1	ARUC1008T1	ARUC1008T1	ARUC1208T1	ARUC1208T1	ARUC1208T1
Product Charge	kg	24	24	24	24	24	24	24
CF(Correction Factor)	kg	-1	0	1	2	3	4	5
Max. Connectable No. of Indoor Units		32	32	32	34	36	38	40
Net Weight	kg	300x3	300x3	300x3	300x3	300x3	300x3	300x3
	lbs	661.4x3	661.4x3	661.4x3	661.4x3	661.4x3	661.4x3	661.4x3
Dimensions (W*H*D)	mm	(1280 * 1607 * 730)x3	(1280 * 1607 * 730)x3	(1280 * 1607 * 730)x3	(1280 * 1607 * 730)x3	(1280 * 1607 * 730)x3	(1280 * 1607 * 730)x3	(1280 * 1607 * 730)x3
	inch	(50.4 * 63.3 * 28.74)x3	(50.4 * 63.3 * 28.74)x3	(50.4 * 63.3 * 28.74)x3	(50.4 * 63.3 * 28.74)x3	(50.4 * 63.3 * 28.74)x3	(50.4 * 63.3 * 28.74)x3	(50.4 * 63.3 * 28.74)x3
Connecting Pipes	Liquid Pipes[mm(inch)]	Ø19.05(3/4)	Ø19.05(3/4)	Ø19.05(3/4)	Ø19.05(3/4)	Ø19.05(3/4)	Ø19.05(3/4)	Ø19.05(3/4)
	Gas Pipes[mm(inch)]	Ø34.9(1 3/8)	Ø34.9(1 3/8)	Ø34.9(1 3/8)	Ø34.9(1 3/8)	Ø41.3(1 5/8)	Ø41.3(1 5/8)	Ø41.3(1 5/8)

## Outdoor Units Information

### ■ Heat Pump

Unit		1 Outdoor Unit(Half size)		1 Outdoor Unit			
System(HP)		5	6	8	10	12	14
Model		ARUN608T1	ARUN608T1	ARUN808T1	ARUN1008T1	ARUN1208T1	ARUN1408T1
Product Charge	kg	6	6	8	8	8	8
CF(Correction Factor)	kg	-1	-1	-1	0	1	2
Max. Connectable No. of Indoor Units		6	8	13	16	20	20
Net Weight	kg	150	150	300	300	300	300
	lbs	330.7	330.7	661.4	661.4	661.4	661.4
Dimensions (W*H*D)	mm	806 * 1607 * 730	806 * 1607 * 730	1280 * 1607 * 730	1280 * 1607 * 730	1280 * 1607 * 730	1280 * 1607 * 730
	inch	31.7 * 63.3 * 28.74	31.7 * 63.3 * 28.74	50.4 * 63.3 * 28.74	50.4 * 63.3 * 28.74	50.4 * 63.3 * 28.74	50.4 * 63.3 * 28.74
Connecting Pipes	Liquid Pipes[mm(inch)]	Ø9.52(3/8)	Ø9.52(3/8)	Ø9.52(3/8)	Ø9.52(3/8)	Ø12.7(1/2)	Ø12.7(1/2)
	Gas Pipes[mm(inch)]	Ø15.88(5/8)	Ø19.05(3/4)	Ø19.05(3/4)	Ø22.2(7/8)	Ø28.58(1 1/8)	Ø28.58(1 1/8)

Unit		2 Outdoor Units					3 Outdoor Units
System(HP)		16	18	20	22	24	26
Model		ARUN1608T1	ARUN1808T1	ARUN2008T1	ARUN2208T1	ARUN2408T1	ARUN2608T1
		ARUN808T1	ARUN1008T1	ARUN1008T1	ARUN1208T1	ARUN1208T1	ARUN1008T1
		ARUH808T1	ARUH808T1	ARUH1008T1	ARUH1008T1	ARUH1208T1	ARUH808T1
							ARUH808T1
Product Charge	kg	16	16	16	16	16	24
CF(Correction Factor)	kg	-2	-1	0	1	2	-2
Max. Connectable No. of Indoor Units		20	20	20	22	24	32
Net Weight	kg	300x2	300x2	300x2	300x2	300x2	300x3
	lbs	661.4x2	661.4x2	661.4x2	661.4x2	661.4x2	661.4x3
Dimensions (W*H*D)	mm	(1280 * 1607 * 730)x2	(1280 * 1607 * 730)x2	(1280 * 1607 * 730)x2	(1280 * 1607 * 730)x2	(1280 * 1607 * 730)x2	(1280 * 1607 * 730)x3
	inch	(50.4 * 63.3 * 28.74)x2	(50.4 * 63.3 * 28.74)x2	(50.4 * 63.3 * 28.74)x2	(50.4 * 63.3 * 28.74)x2	(50.4 * 63.3 * 28.74)x2	(50.4 * 63.3 * 28.74)x3
Connecting Pipes	Liquid Pipes[mm(inch)]	Ø12.7(1/2)	Ø15.88(5/8)	Ø15.88(5/8)	Ø15.88(5/8)	Ø15.88(5/8)	Ø19.05(3/4)
	Gas Pipes[mm(inch)]	Ø28.58(1 1/8)	Ø28.58(1 1/8)	Ø28.58(1 1/8)	Ø28.58(1 1/8)	Ø34.9(1 3/8)	Ø34.9(1 3/8)

Unit		3 Outdoor Units						
System(HP)		28	30	32	34	36	38	40
Model		ARUN2808T1	ARUN3008T1	ARUN3208T1	ARUN3408T1	ARUN3608T1	ARUN3808T1	ARUN4008T1
		ARUN1008T1	ARUN1008T1	ARUN1208T1	ARUN1208T1	ARUN1208T1	ARUN1408T1	ARUN1408T1
		ARUH1008T1	ARUH1008T1	ARUH1008T1	ARUH1208T1	ARUH1208T1	ARUH1208T1	ARUH1408T1
		ARUH808T1	ARUH1008T1	ARUH1008T1	ARUH1008T1	ARUH1208T1	ARUH1208T1	ARUH1208T1
Product Charge	kg	24	24	24	24	24	24	24
CF(Correction Factor)	kg	-1	0	1	2	3	4	5
Max. Connectable No. of Indoor Units		32	32	32	34	36	38	40
Net Weight	kg	300x3	300x3	300x3	300x3	300x3	300x3	300x3
	lbs	661.4x3	661.4x3	661.4x3	661.4x3	661.4x3	661.4x3	661.4x3
Dimensions (W*H*D)	mm	(1280 * 1607 * 730)x3	(1280 * 1607 * 730)x3	(1280 * 1607 * 730)x3	(1280 * 1607 * 730)x3	(1280 * 1607 * 730)x3	(1280 * 1607 * 730)x3	(1280 * 1607 * 730)x3
	inch	(50.4 * 63.3 * 28.74)x3	(50.4 * 63.3 * 28.74)x3	(50.4 * 63.3 * 28.74)x3	(50.4 * 63.3 * 28.74)x3	(50.4 * 63.3 * 28.74)x3	(50.4 * 63.3 * 28.74)x3	(50.4 * 63.3 * 28.74)x3
Connecting Pipes	Liquid Pipes[mm(inch)]	Ø19.05(3/4)	Ø19.05(3/4)	Ø19.05(3/4)	Ø19.05(3/4)	Ø19.05(3/4)	Ø19.05(3/4)	Ø19.05(3/4)
	Gas Pipes[mm(inch)]	Ø34.9(1 3/8)	Ø34.9(1 3/8)	Ø34.9(1 3/8)	Ø34.9(1 3/8)	Ø41.3(1 5/8)	Ø41.3(1 5/8)	Ø41.3(1 5/8)

**Power Supply: Outdoor unit (3Ø, 380V, 60Hz)****■ Cooling Only**

Unit		1 outdoor unit(half size)			1 outdoor unit		
System(HP)		5	6	8	10	12	14
Model		ARUV509T1	ARUV609T1	ARUV809T1	ARUV1009T1	ARUV1209T1	ARUV1409T1
Product Charge	kg	6	6	6	8	8	8
CF(Correction Factor)	kg	-1	-1	0	0	1	2
Max. Connectable No. of Indoor Units		6	8	13	16	16	16
Net Weight	kg	150	150	150	300	300	300
	lbs	330.7	330.7	330.7	661.4	661.4	661.4
Dimensions (W*H*D)	mm	806 * 1607 * 730	806 * 1607 * 730	806 * 1607 * 730	1280 * 1607 * 730	1280 * 1607 * 730	1280 * 1607 * 730
	inch	31.7 * 63.3 * 28.74	31.7 * 63.3 * 28.74	31.7 * 63.3 * 28.74	50.4 * 63.3 * 28.74	50.4 * 63.3 * 28.74	50.4 * 63.3 * 28.74
Connecting Pipes	Liquid Pipes[mm(inch)]	Ø9.52(3/8)	Ø9.52(3/8)	Ø9.52(3/8)	Ø9.52(3/8)	Ø12.7(1/2)	Ø12.7(1/2)
	Gas Pipes[mm(inch)]	Ø15.88(5/8)	Ø19.05(3/4)	Ø19.05(3/4)	Ø22.2(7/8)	Ø28.58(1 1/8)	Ø28.58(1 1/8)

Unit		2 outdoor units					
System(HP)		16	18	20	22	24	26
Model		ARUV1609T1	ARUV1809T1	ARUV2009T1	ARUV2209T1	ARUV2409T1	ARUV2609T1
		ARUV809T1	ARUV1009T1	ARUV1009T1	ARUV1209T1	ARUV1209T1	ARUV1409T1
		ARUC809T1	ARUC809T1	ARUC1009T1	ARUC1009T1	ARUC1209T1	ARUC1209T1
Product Charge	kg	16	16	16	16	16	16
CF(Correction Factor)	kg	-2	-1	0	1	2	3
Max. Connectable No. of Indoor Units		20	20	20	22	24	26
Net Weight	kg	300x2	300x2	300x2	300x2	300x2	300x2
	lbs	661.4x2	661.4x2	661.4x2	661.4x2	661.4x2	661.4x2
Dimensions (W*H*D)	mm	(1280 * 1607 * 730)x2	(1280 * 1607 * 730)x2	(1280 * 1607 * 730)x2	(1280 * 1607 * 730)x2	(1280 * 1607 * 730)x2	(1280 * 1607 * 730)x2
	inch	(50.4 * 63.3 * 28.74)x2	(50.4 * 63.3 * 28.74)x2	(50.4 * 63.3 * 28.74)x2	(50.4 * 63.3 * 28.74)x2	(50.4 * 63.3 * 28.74)x2	(50.4 * 63.3 * 28.74)x2
Connecting Pipes	Liquid Pipes[mm(inch)]	Ø12.7(1/2)	Ø15.88(5/8)	Ø15.88(5/8)	Ø15.88(5/8)	Ø15.88(5/8)	Ø19.05(3/4)
	Gas Pipes[mm(inch)]	Ø28.58(1 1/8)	Ø28.58(1 1/8)	Ø28.58(1 1/8)	Ø28.58(1 1/8)	Ø34.9(1 3/8)	Ø34.9(1 3/8)

Unit		3 outdoor units						
System(HP)		28	30	32	34	36	38	40
Model		ARUV2809T1	ARUV3009T1	ARUV3209T1	ARUV3409T1	ARUV3609T1	ARUV3809T1	ARUV4009T1
		ARUV1009T1	ARUV1009T1	ARUV1209T1	ARUV1209T1	ARUV1209T1	ARUV1409T1	ARUV1409T1
		ARUC1009T1	ARUC1009T1	ARUC1009T1	ARUC1209T1	ARUC1209T1	ARUC1209T1	ARUC1409T1
		ARUC809T1	ARUC1009T1	ARUC1009T1	ARUC1009T1	ARUC1209T1	ARUC1209T1	ARUC1209T1
Product Charge	kg	24	24	24	24	24	24	24
CF(Correction Factor)	kg	-1	0	1	2	3	4	5
Max. Connectable No. of Indoor Units		32	32	32	34	36	38	40
Net Weight	kg	300x3	300x3	300x3	300x3	300x3	300x3	300x3
	lbs	661.4x3	661.4x3	661.4x3	661.4x3	661.4x3	661.4x3	661.4x3
Dimensions (W*H*D)	mm	(1280 * 1607 * 730)x3	(1280 * 1607 * 730)x3	(1280 * 1607 * 730)x3	(1280 * 1607 * 730)x3	(1280 * 1607 * 730)x3	(1280 * 1607 * 730)x3	(1280 * 1607 * 730)x3
	inch	(50.4 * 63.3 * 28.74)x3	(50.4 * 63.3 * 28.74)x3	(50.4 * 63.3 * 28.74)x3	(50.4 * 63.3 * 28.74)x3	(50.4 * 63.3 * 28.74)x3	(50.4 * 63.3 * 28.74)x3	(50.4 * 63.3 * 28.74)x3
Connecting Pipes	Liquid Pipes[mm(inch)]	Ø19.05(3/4)	Ø19.05(3/4)	Ø19.05(3/4)	Ø19.05(3/4)	Ø19.05(3/4)	Ø19.05(3/4)	Ø19.05(3/4)
	Gas Pipes[mm(inch)]	Ø34.9(1 3/8)	Ø34.9(1 3/8)	Ø34.9(1 3/8)	Ø34.9(1 3/8)	Ø41.3(1 5/8)	Ø41.3(1 5/8)	Ø41.3(1 5/8)

## Outdoor Units Information

### ■ Heat Pump

Unit		1 outdoor unit(half size)		1 outdoor unit			
System(HP)		5	6	8	10	12	14
Model		ARUN509T1	ARUN609T1	ARUN809T1	ARUN1009T1	ARUN1209T1	ARUN1409T1
Product Charge	kg	6	6	8	8	8	8
CF(Correction Factor)	kg	-1	-1	-1	0	1	2
Max. Connectable No. of Indoor Units		6	8	13	16	20	20
Net Weight	kg	150	150	300	300	300	300
	lbs	330.7	330.7	661.4	661.4	661.4	661.4
Dimensions (W*H*D)	mm	806 * 1607 * 730	806 * 1607 * 730	1280 * 1607 * 730	1280 * 1607 * 730	1280 * 1607 * 730	1280 * 1607 * 730
	inch	31.7 * 63.3 * 28.74	31.7 * 63.3 * 28.74	50.4 * 63.3 * 28.74	50.4 * 63.3 * 28.74	50.4 * 63.3 * 28.74	50.4 * 63.3 * 28.74
Connecting Pipes	Liquid Pipes[mm(inch)]	Ø9.52(3/8)	Ø9.52(3/8)	Ø9.52(3/8)	Ø9.52(3/8)	Ø12.7(1/2)	Ø12.7(1/2)
	Gas Pipes[mm(inch)]	Ø15.88(5/8)	Ø19.05(3/4)	Ø19.05(3/4)	Ø22.2(7/8)	Ø28.58(1 1/8)	Ø28.58(1 1/8)

Unit		2 outdoor units					
System(HP)		16	18	20	22	24	26
Model		ARUN1609T1	ARUN1809T1	ARUN2009T1	ARUN2209T1	ARUN2409T1	ARUN2609T1
		ARUN809T1	ARUN1009T1	ARUN1009T1	ARUN1209T1	ARUN1209T1	ARUN1409T1
		ARUH809T1	ARUH809T1	ARUH1009T1	ARUH1009T1	ARUH1209T1	ARUH1209T1
Product Charge	kg	16	16	16	16	16	16
CF(Correction Factor)	kg	-2	-1	0	1	2	3
Max. Connectable No. of Indoor Units		20	20	20	22	24	26
Net Weight	kg	300 x2	300 x2	300 x2	300 x2	300 x2	300 x2
	lbs	661.4 x2	661.4 x2	661.4 x2	661.4 x2	661.4 x2	661.4 x2
Dimensions (W*H*D)	mm	(1280 * 1607 * 730)x2	(1280 * 1607 * 730)x2	(1280 * 1607 * 730)x2	(1280 * 1607 * 730)x2	661.4 x2	661.4 x2
	inch	(50.4 * 63.3 * 28.74)x2	(50.4 * 63.3 * 28.74)x2	(50.4 * 63.3 * 28.74)x2	(50.4 * 63.3 * 28.74)x2	(50.4 * 63.3 * 28.74)x2	(50.4 * 63.3 * 28.74)x2
Connecting Pipes	Liquid Pipes[mm(inch)]	Ø12.7(1/2)	Ø15.88(5/8)	Ø15.88(5/8)	Ø15.88(5/8)	Ø15.88(5/8)	Ø19.05(3/4)
	Gas Pipes[mm(inch)]	Ø28.58(1 1/8)	Ø28.58(1 1/8)	Ø28.58(1 1/8)	Ø28.58(1 1/8)	Ø34.9(1 3/8)	Ø34.9(1 3/8)

Unit		3 outdoor units						
System(HP)		28	30	32	34	36	38	40
Model		ARUN2809T1	ARUN3009T1	ARUN3209T1	ARUN3409T1	ARUN3609T1	ARUN3809T1	ARUN4009T1
		ARUN1009T1	ARUN1009T1	ARUN1209T1	ARUN1209T1	ARUN1209T1	ARUN1409T1	ARUN1409T1
		ARUH1009T1	ARUH1009T1	ARUH1009T1	ARUH1209T1	ARUH1209T1	ARUH1209T1	ARUH1409T1
		ARUH809T1	ARUH1009T1	ARUH1009T1	ARUH1009T1	ARUH1209T1	ARUH1209T1	ARUH1209T1
Product Charge	kg	24	24	24	24	24	24	24
CF(Correction Factor)	kg	-1	0	1	2	3	4	5
Max. Connectable No. of Indoor Units		32	32	32	34	36	38	40
Net Weight	kg	300x3	300x3	300x3	300x3	300x3	300x3	300x3
	lbs	661.4x3	661.4x3	661.4x3	661.4x3	661.4x3	661.4x3	661.4x3
Dimensions (W*H*D)	mm	(1280 * 1607 * 730)x3	(1280 * 1607 * 730)x3	(1280 * 1607 * 730)x3	(1280 * 1607 * 730)x3	(1280 * 1607 * 730)x3	(1280 * 1607 * 730)x3	(1280 * 1607 * 730)x3
	inch	(50.4 * 63.3 * 28.74)x3	(50.4 * 63.3 * 28.74)x3	(50.4 * 63.3 * 28.74)x3	(50.4 * 63.3 * 28.74)x3	(50.4 * 63.3 * 28.74)x3	(50.4 * 63.3 * 28.74)x3	(50.4 * 63.3 * 28.74)x3
Connecting Pipes	Liquid Pipes[mm(inch)]	Ø19.05(3/4)	Ø19.05(3/4)	Ø19.05(3/4)	Ø19.05(3/4)	Ø19.05(3/4)	Ø19.05(3/4)	Ø19.05(3/4)
	Gas Pipes[mm(inch)]	Ø34.9(1 3/8)	Ø34.9(1 3/8)	Ø34.9(1 3/8)	Ø34.9(1 3/8)	Ø41.3(1 5/8)	Ø41.3(1 5/8)	Ø41.3(1 5/8)

## Environment-friendly Alternative Refrigerant R410A

- The refrigerant R410A has the property of higher operating pressure in comparison with R22. Therefore, all materials have the characteristics of higher resisting pressure than R22 ones and this characteristic should be also considered during the installation. R410A is an azeotrope of R32 and R125 mixed at 50:50, so the ozone depletion potential (ODP) of R410A is 0. These days the developed countries have approved it as the environmental-friendly refrigerant and encouraged to use it widely to prevent environmental pollution.



### CAUTION:

- The wall thickness of the piping should comply with the relevant local and national regulations for the designed pressure 3.8MPa
- Since R410A is a mixed refrigerant, the required additional refrigerant must be charged in its liquid state. If the refrigerant is charged in its gaseous state, its composition changes and the system will not work properly.
- Do not place the refrigerant container under the direct rays of the sun to prevent it from exploding.
- For high-pressure refrigerant, any unapproved pipe must not be used.
- Do not heat up pipes more than its necessity to prevent them from softening.
- Be careful not to install wrongly to minimize economic loss because it is expensive in comparison with R22.

## Select the Best Location

Select space for installing outdoor unit, which will meet the following conditions:

- No direct thermal radiation from other heat sources
- No possibility of annoying the neighbors by noise from unit
- No exposition to strong wind
- With strength which bears weight of unit
- Note that drain flows out of unit when heating
- With space for air passage and service work shown next
- Because of the possibility of fire, do not install unit to the space where generation, inflow, stagnation, and leak of combustible gas is expected.
- Avoid unit installation in a place where acidic solution and spray (sulfur) are often used.
- Do not use unit under any special environment where oil, steam and sulfuric acid exist.
- It is recommended to fence round the outdoor unit in order to prevent any person or animal from accessing the outdoor unit.
- If installation site is area of heavy snowfall, then the following directions should be observed.
  - Make the foundation as high as possible.
  - Fit a snow protection hood.
- Select installation location considering following conditions to avoid bad condition when additionally performing defrost operation.
  1. Install the outdoor unit at a place well ventilated and having a lot of sunshine in case of installing the product at a place with a high humidity in winter (near beach, coast, lake, etc).  
(Ex) Rooftop where sunshine always shines.
  2. Performance of heating will be reduced and preheat time of the indoor unit may be lengthened in case of installing the outdoor unit in winter at following location:
    - (1) Shade position with a narrow space
    - (2) Location with much moisture in neighboring floor.
    - (3) Location with much humidity around.
    - (4) Location where ventilation is good.

It is recommended to install the outdoor unit at a place with a lot of sunshine as possible as.
  - (5) Location where water gathers since the floor is not even.

# Installation Space

## Individual Installation

### Basic space required

A space of at least 250 mm is necessary at the back for inlet air. Taking servicing, etc. from the rear into account, a space of about 900 mm should be provided, the same as at the front.

- Ⓐ 250 mm or more
- Ⓑ 900 mm or more (Control box is of a open/close type)
- Ⓒ Top discharge (open in principle)
- Ⓓ Front inlet (open in principle)
- Ⓔ Rear inlet (open in principle)

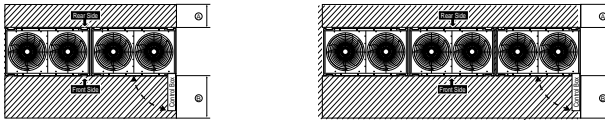
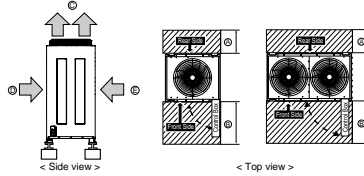

### When inlet air enters from right and left sides of unit

- Ⓐ 900 mm or more  
(Control box is of a open/close type)
- Ⓑ 250 mm or more
- Ⓒ 150 mm from the wall

**CAUTION**

Wall height(H) must not exceed height of the product. If the wall height is higher than the whole height of product by (h), Add (h) to Ⓐ, Ⓑ.

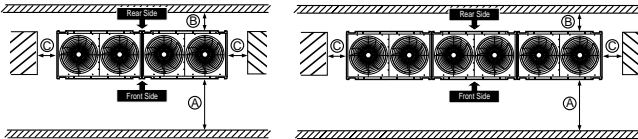
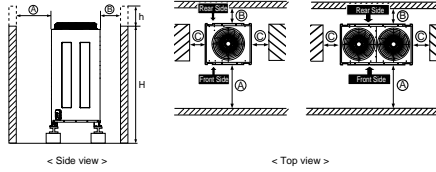

- Ⓐ 250 mm or more  
(350mm or more at the coastal area)
- Ⓑ 150 mm from the wall

**CAUTION**

Wall height(H) must not exceed height of the product. If the wall height is higher than the whole height of product by (h), Add (h) to Ⓐ, Ⓑ.

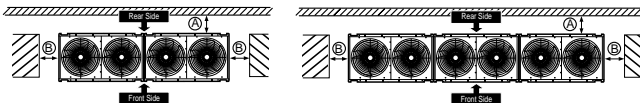
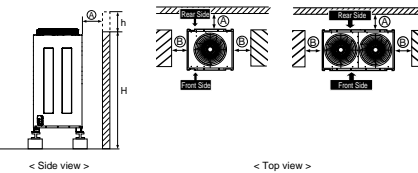

■ When unit is surrounded by walls

- Ⓐ 900 mm or more (Control box is of a open/close type)
- Ⓑ 250 mm or more

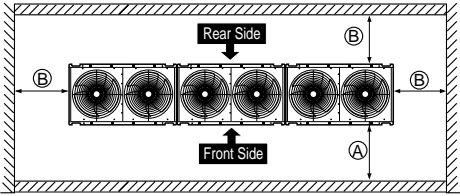
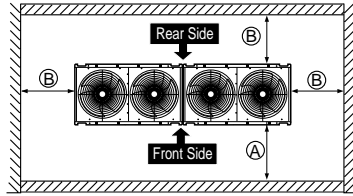
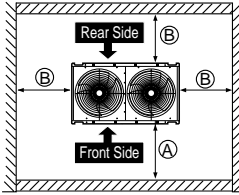
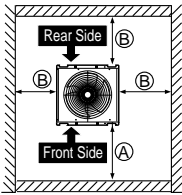

■ When there is an obstruction above the unit

- Ⓐ 45° or more
- Ⓑ 200 mm or more
- Ⓒ 250 mm or more

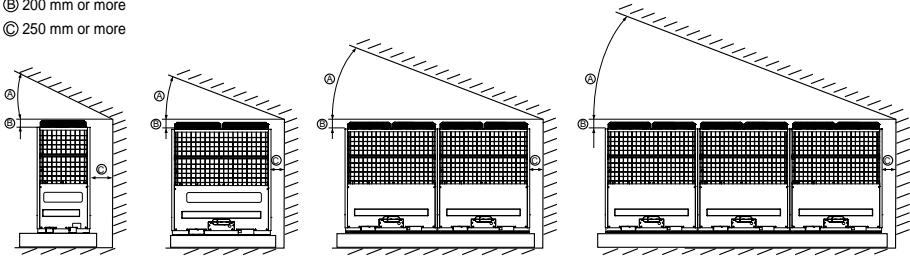

< Front view >

- Ⓓ 1000 mm or more
- Ⓔ Air outlet guide (Procured at the site)
- Ⓕ 250 mm or more

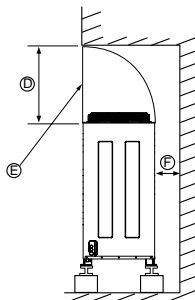

< Side view >

**Collective / Continuous installation**

Space required for collective installation and continuous installation: When installing several units, leave the space between each block as shown below considering passage for air and people.

- (A) (Be opened)
- (B) 900mm or more (control box is of a open/close type)
- (C) 250 mm or more

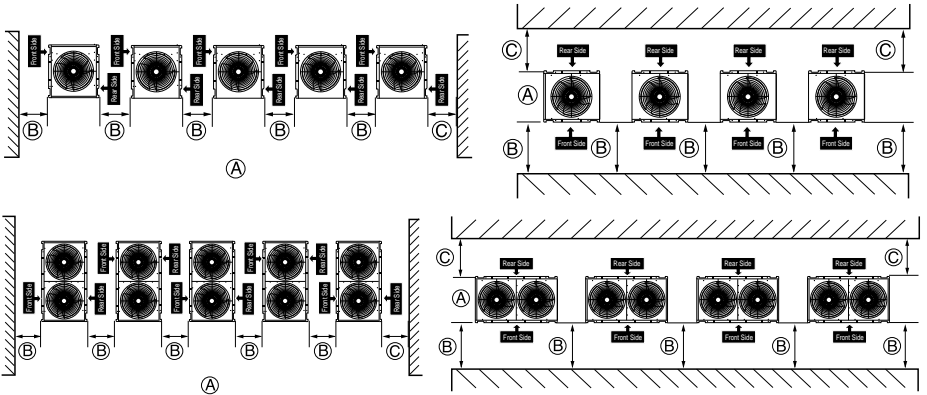

⊗ (B) = 1250mm or more at the coastal area

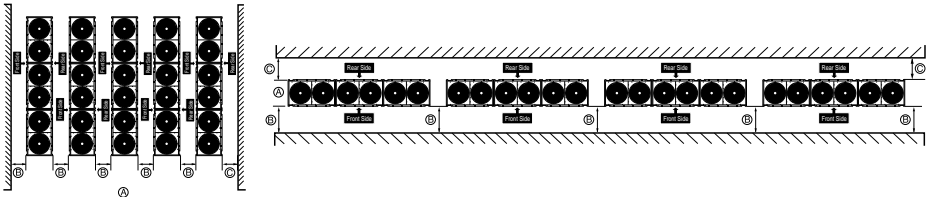
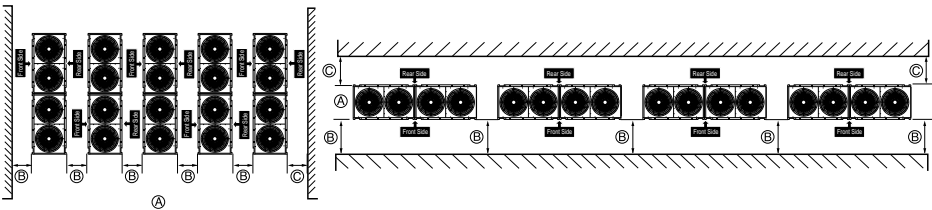
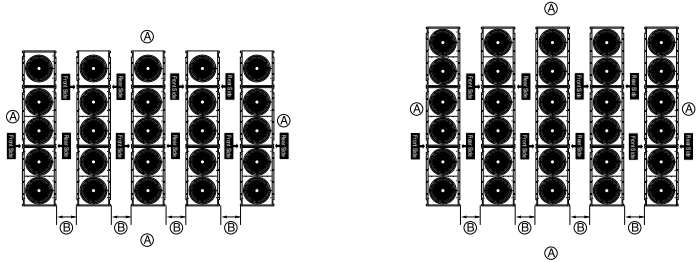

**Cautions in winter especially for seasonal wind**

- Sufficient measures are required at a snow area or severe cold area in winter so that product can be operated well.
- Get ready for seasonal wind or snow in winter even in other area.
- Install a suction and discharge duct not to let in snow or rain when the product operates at outdoor temperature of less than 10°C.
- Install the outdoor unit not to come in contact with snow directly. If snow piles up and freezes on the air suction hole, the system may malfunction. If it is installed at snowy area, attach the hood to the system.
- Install the outdoor unit at the higher installation console by 50cm than the average snowfall (annual average snowfall) if it is installed at the area with much snowfall.
- Where snow accumulated on the upper part of the outdoor unit by more than 10cm, always remove snow for operation.

1. The height of H frame must be more than 2 times the snowfall and its width shall not exceed the width of the product. (If width of the frame is wider than that of the product, snow may accumulate)
2. Don't install the suction hole and discharge hole of the outdoor unit facing to the seasonal wind.

**CAUTION**

- **Always apply main power of the outdoor unit during use of product (cooling season/heating season).**
- **Always apply power before 6 hours to heat the crank case heater where performing test run after installation of product or where operating the product after cutting the main power of the outdoor unit (for example, power failure). It may result in burning out of the compressor if not preheating the crank case with the electrical heater for more than 6 hours.(In case of the outdoor temperature below 10°C)**

## Lifting method

- When carrying the unit suspended, pass the ropes under the unit and use the two suspension points each at the front and rear.
- Always lift the unit with ropes attached at four points so that impact is not applied to the unit.
- Attach the ropes to the unit at an angle of 40° or less.

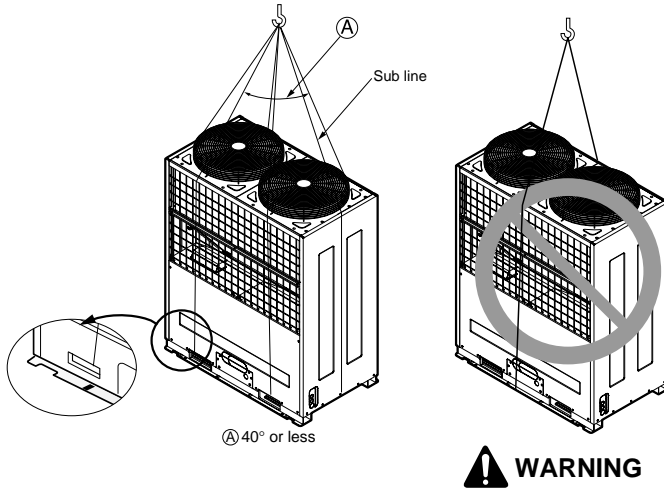

### **! CAUTION**

#### **Be very careful to carry product.**

- Do not have only one person carry product if it is more than 20 kg.
- PP bands are used to pack some products. Do not use them as a mean for transportation because they are dangerous.
- Do not touch heat exchanger fins with your bare hands. Otherwise you may get a cut in your hands.
- Tear plastic packaging bag and scrap it so that children cannot play with it. Otherwise plastic packaging bag may suffocate children to death.
- When carrying in outdoor unit, be sure to support it at four points. Carrying in and lifting with 3-point support may make outdoor unit unstable, resulting in a fall of it.

# Installation

## Location of anchor bolt

### Individual installation

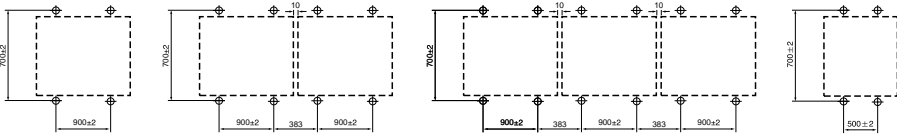

### Example of collective installation

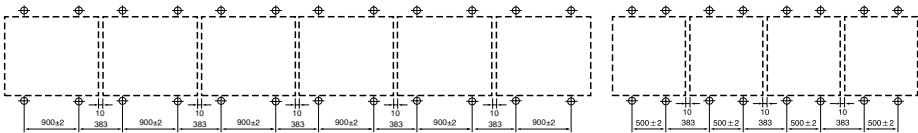

### Installation foot (Location of anchor bolt)

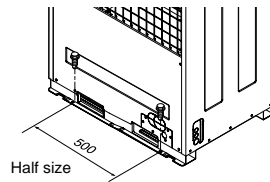
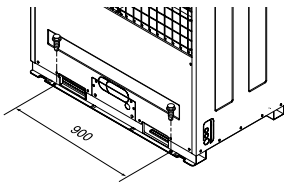

## Foundation for Installation

- Fix the unit tightly with bolts as shown below so that unit will not fall down due to earthquake or gust.
- Use the H-beam support as a base support
- Noise and vibration may occur from the floor or wall since vibration is transferred through the installation part depending on installation status. Thus, use anti-vibration materials (cushion pad) fully (The base pad shall be more than 200mm).

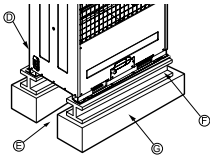
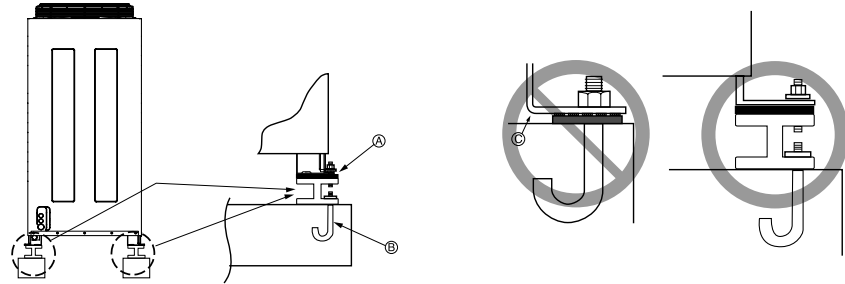

- Ⓐ Ensure that the corner part can be securely mounted. Otherwise, the support for installation may be bent.
- Ⓑ Obtain and use the M10 anchor bolt.
- Ⓒ The corner was not properly mounted.
- Ⓓ Outdoor unit (Insert the cushion pad between outdoor unit and base support to ensure that anti-vibration may be done in a wide area)
- Ⓔ Pipe and wiring space (in case of piping and wiring on the floor surface)
- Ⓕ H-Beam support
- Ⓖ Concrete base support

### WARNING

- Be sure to install unit in a place strong enough to withstand its weight. Any lack of strength may cause unit to fall down, resulting in a personal injury.
- Have installation work in order to protect against a strong wind and earthquake. Any installation deficiency may cause unit to fall down, resulting in a personal injury.
- Especially take care for support strength of the floor surface, water drain processing (processing of water flown out from the outdoor unit during operation) and paths of the pipe and wiring when making a base support.
- Don't use a tube or pipe for water drain in the base pan and perform water drain processing by using the drain path. Water drain may not be done due to freezing of a tube or pipe.

Rear view

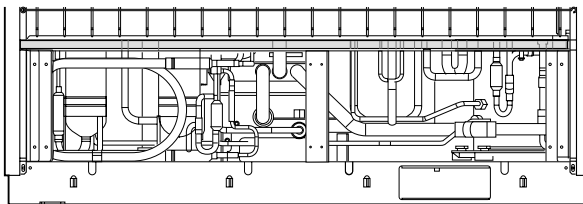

Side view

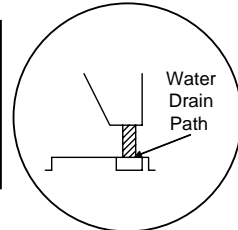

## Preparation of Piping

Main cause of gas leakage is defect in flaring work. Carry out correct flaring work in the following procedure.

### 1) Cut the pipes and the cable.

- Use the accessory piping kit or the pipes purchased locally.
- Measure the distance between the indoor and the outdoor unit.
- Cut the pipes a little longer than measured distance.
- Cut the cable 1.5m longer than the pipe length.

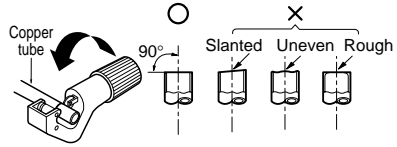

### 2) Burrs removal

- Completely remove all burrs from the cut cross section of pipe/tube.
- Put the end of the copper tube/pipe to downward direction as you remove burrs in order to avoid to let burrs drop in the tubing.

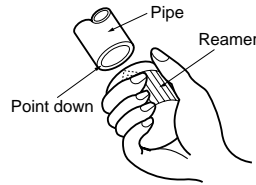

### 3) Flaring work

- Carry out flaring work using flaring tool as shown below.

Indoor unit [kW(Btu/h)]	Pipe		" A "	
	Gas	Liquid	Gas	Liquid
<5.6(19,100)	1/2"	1/4"	0.5~0.8	0~0.5
<16.0(54,600)	5/8"	3/8"	0.8~1.0	0.5~0.8
<22.4(76,400)	3/4"	3/8"	1.0~1.3	0.5~0.8

Firmly hold copper tube in a bar(or die) as indicated dimension in the table above.

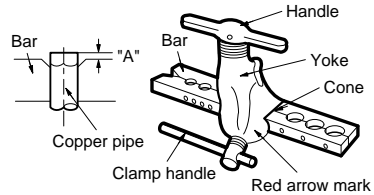

### 4) Check

- Compare the flared work with figure below.
- If flare is noted to be defective, cut off the flared section and do flaring work again.

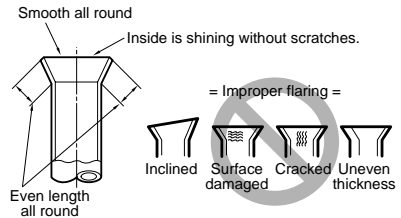

**FLARE SHAPE and FLARE NUT TIGHTENING TORQUE**

**Precautions when connecting pipes**

- See the following table for flare part machining dimensions.
- When connecting the flare nuts, apply refrigerant oil to the inside and outside of the flares and turn them three or four times at first. (Use ester oil or ether oil.)
- See the following table for tightening torque.(Applying too much torque may cause the flares to crack.)
- After all the piping has been connected, use nitrogen to perform a gas leak check.

pipe size	tightening torque(Ncm)	A(mm)	flare shape
Ø9.5	3270-3990	12.8-13.2	
Ø12.7	4950-6030	16.2-16.6	
Ø15.9	6180-7540	19.3-19.7	

**CAUTION**

- Always use a charge hose for service port connection.
- After tightening the cap, check that no refrigerant leaks are present.
- When loosening a flare nut, always use two wrenches in combination, When connecting the piping, always use a spanner and torque wrench in combination to tighten the flare nut.
- When connecting a flare nut, coat the flare(inner and outer faces) with oil for R410A(PVE) and hand tighten the nut 3 to 4 turns as the initial tightening.

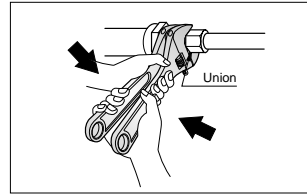

**Opening shutoff valve**

1. Remove the cap and turn the valve counter clockwise with the hexagon wrench.
2. Turn it until the shaft stops.  
Do not apply excessive force to the shutoff valve. Doing so may break the valve body, as the valve is not a backseat type. Always use the special tool.
3. Make sure to tighten the cap securely.

**Closing shutoff valve**

1. Remove the cap and turn the valve clockwise with the hexagon wrench.
2. Securely tighten the valve until the shaft contacts the main body seal.
3. Make sure to tighten the cap securely.  
\* For the tightening torque, refer to the table on the below.

**Tightening torque**

Shutoff valve size	Tightening torque N-m(Turn clockwise to close)					
	Shaft(valve body)		Cap(Valve lid)	Service port	Flare nut	Gas line piping attached to unit
Ø6.4	5.4-6.6	Hexagonal wrench 4mm	13.5-16.5	11.5-13.9	14-17	-
Ø9.5			18-22		33-39	
Ø12.7	8.1-9.9	23-27	50-60			
Ø15.9	13.5-16.5	36-44	62-75			
Ø22.2	27-33	Hexagonal wrench 10mm	-	-	22-28	
Ø25.4			-	-	-	

## HEAT INSULATION

1. Use the heat insulation material for the refrigerant piping which has an excellent heat-resistance (over 120°C).

2. Precautions in high humidity circumstance:

This air conditioner has been tested according to the "ISO Conditions with Mist" and confirmed that there is not any default. However, if it is operated for a long time in high humid atmosphere (dew point temperature: more than 23°C), water drops are liable to fall. In this case, add heat insulation material according to the following procedure:

- Heat insulation material to be prepared... Adiabatic glass wool with thickness 10 to 20mm.
- Stick glass wool on all air conditioners that are located in ceiling atmosphere.
- In addition to the normal heat insulation (thickness: more than 8mm) for refrigerant piping (gas piping: thick piping) and drain piping, add further 10mm to 30mm thickness material.

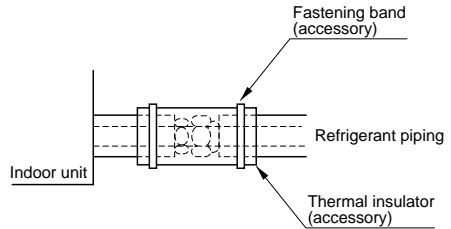

# Refrigerant piping installation

The method of connection consists of flare connections at the indoor units, flange connections for the piping of the outdoor unit and flare connections for the liquid piping. Note that the branched sections are brazed.

## ⚠ WARNING

Always use extreme care to prevent the refrigerant gas (R410A) from the leakage while using fire or flame. If the refrigerant gas comes in contact with the flame from any source, such as a gas stove, it breaks down and generates a poisonous gas which can cause gas poisoning. Never perform brazing in an unventilated room. Always conduct an inspection for gas leakage after installation of the refrigerant piping has been completed.

## Cautions in pipe connection/valve operation

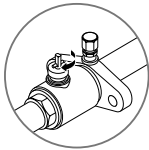

Open status when both the pipe and the valve are in a straight line.

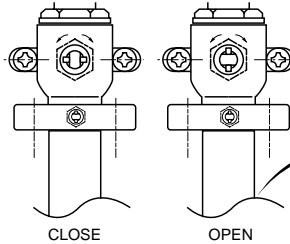

Cut both the pipe and the valve with a cutter to suit the length  
(Don't cut the length of less than 70mm)

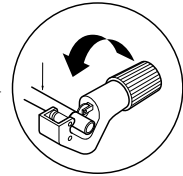

## ⚠ WARNING

After completing work, securely tighten both service ports and caps so that gas does not leak.

- ① Pipe joint (auxiliary parts): Securely perform brazing with a nitrogen blow into the service valve port. (Releasing pressure : 0.02 MPa or less)
- ② Flare nut: Loose or tighten flare nut by using the wrench with both ends. Coat the flare connection part with oil for the compressor.
- ③ Cap: Remove caps and operate valve, etc. After operation, always reattach caps (tightening torque of valve cap: 25Nm (250kg-cm) or more). (Don't remove the internal part of the port)
- ④ Service port: Make the refrigerant pipe vacuum and charge it using the service port. Always reattach caps after completing work (tightening torque of service cap: 14Nm (140kg-cm) or more).
- ⑤ Liquid pipe
- ⑥ Gas pipe
- ⑦ Elbow joint (field supply)

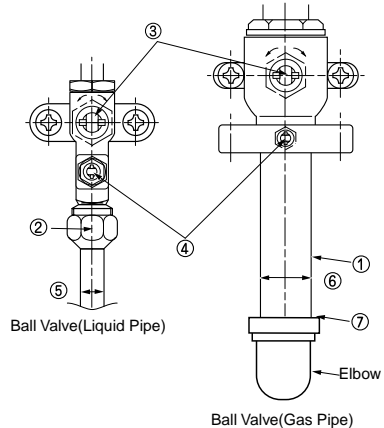

## Connection of High/Low Pressure Common pipe

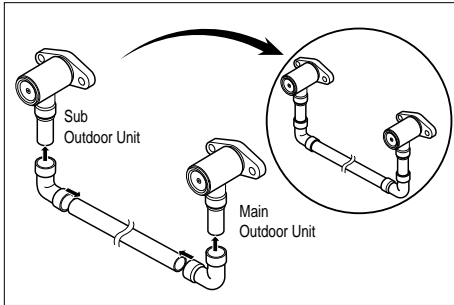

**2 outdoor units**

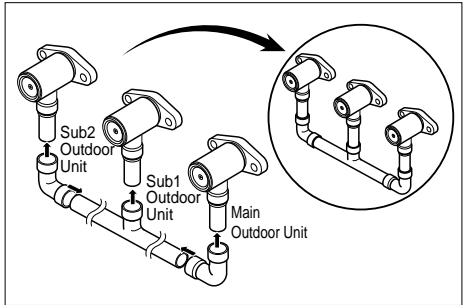

**3 outdoor units**

1. For the high/low pressure common pipe, connect both main outdoor unit and sub outdoor units to the pipe (field supply) by using elbows (field supply)
2. For cutting the pipe, connect the high/low pressure common pipe after removing burrs, dusts and foreign materials within the pipe. Otherwise, the product may not operate due to sludge within the pipe.

When connecting the pipes from the front of the outdoor unit, remove part ①.

When connecting the pipes from the side of the outdoor unit, remove part ② (the whole "Knock out" part).

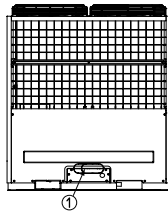

(Front)

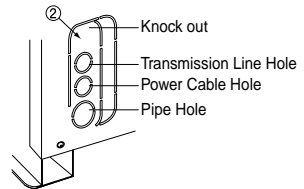

(Side)

### **⚠ WARNING**

After installing the pipe, clog the pipe excavation inlet of the front panel and the side panel (Wire may be damaged due to entering of rats, animals, etc).

## Connection of Outdoor units

### 2 outdoor units

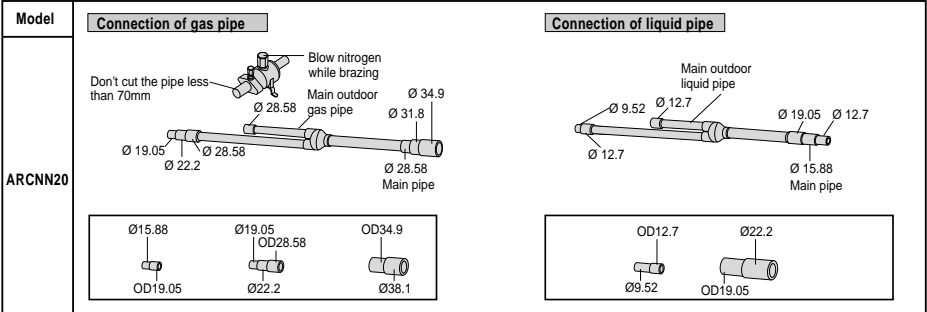

### 3 outdoor units

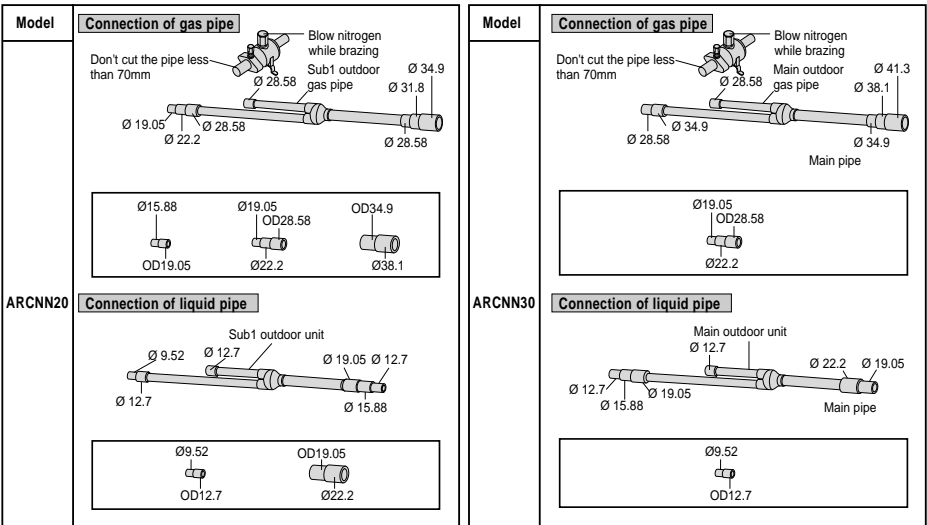

■ Y branch

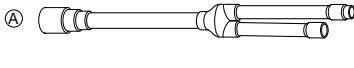

- Ⓐ To outdoor unit
- Ⓑ To branch piping or indoor unit

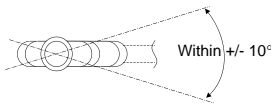

Viewed from point A in direction of arrow

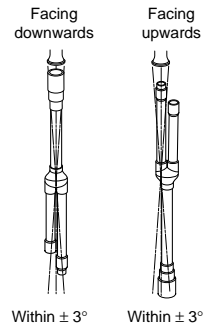

**Caution**

- Use the following materials for refrigerant piping.
  - Material: Seamless phosphorous deoxidized copper pipe
  - Wall thickness : Comply with the relevant local and national regulations for the designed pressure 3.8MPa. We recommend the following table as the minimum wall thickness.

Outer diameter [mm]	6.35	9.52	12.7	15.88	19.05	22.2	25.4	28.58	31.8	34.9	38.1	41.3
Minimum thickness [mm]	0.8	0.8	0.8	0.99	0.99	0.99	0.99	0.99	1.1	1.21	1.35	1.43

- Commercially available piping often contains dust and other materials. Always blow it clean with a dry inert gas.
- Use care to prevent dust, water or other contaminants from entering the piping during installation.
- Reduce the number of bending portions as much as possible, and make bending radius as big as possible.
- Always use the branch piping set shown below, which are sold separately.

Y branch		Header		
		4 branch	7 branch	10 branch
ARBLN02220	ARBLN03320	ARBL054	ARBL057	ARBL1010
ARBLN07120	ARBLN14520	ARBL104	ARBL107	ARBL2010

- If the diameters of the branch piping of the designated refrigerant piping differs, use a pipe cutter to cut the connecting section and then use an adapter for connecting different diameters to connect the piping.
- Always observe the restrictions on the refrigerant piping (such as rated length, difference in height, and piping diameter).  
Failure to do so can result in equipment failure or a decline in heating/cooling performance.
- A second branch cannot be made after a header. (These are shown by ⊘.)

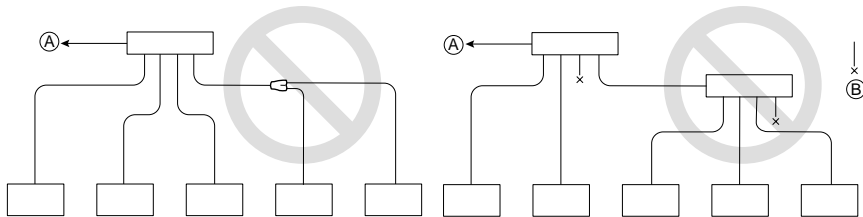

(A) To outdoor unit

(B) Sealed piping

- The system will stop due to an abnormality like excessive or insufficient refrigerant. At such a time, always properly charge the unit. When servicing, always check the notes concerning both the piping length and the amount of additional refrigerant.
- Never perform a pump down. This will not only damage the compressor but also deteriorate the performance.**
- Never use refrigerant to perform an air purge. Always evacuate using a vacuum pump.**

## Refrigerant piping installation

- Always insulate the piping properly. Insufficient insulation will result in a decline in heating/cooling performance, drip of condensate and other such problems.
- When connecting the refrigerant piping, make sure the service valves of the outdoor unit is completely closed (the factory setting) and do not operate it until the refrigerant piping for the outdoor and indoor units has been connected, a refrigerant leakage test has been performed and the evacuation process has been completed.
- Always use a non-oxidizing brazing material for brazing the parts and do not use flux. If not, oxidized film can cause clogging or damage to the compressors and flux can harm the copper piping or refrigerant oil.

### WARNING

**When installing and moving the air conditioner to another site, be sure to make recharge refrigerant after perfect evacuation.**

- If a different refrigerant or air is mixed with the original refrigerant, the refrigerant cycle may malfunction and the unit may be damaged.
- After selecting diameter of the refrigerant pipe to suit total capacity of the indoor unit connected after branching, use an appropriate branch pipe set according to the pipe diameter of the indoor unit and the installation pipe drawing.

## Pipe length between Outdoor Units (Gas pipe, Liquid pipe, High/Low Pressure Common pipe)

= Product length (1,280) +  $\alpha$  (distance between outdoor units)

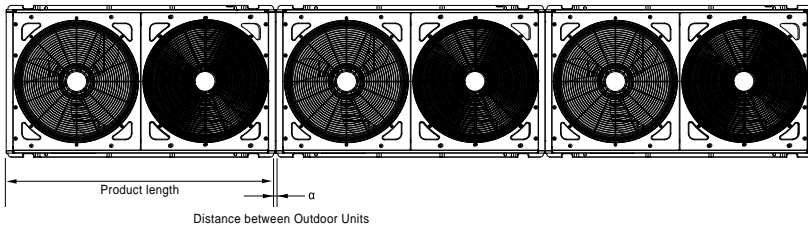
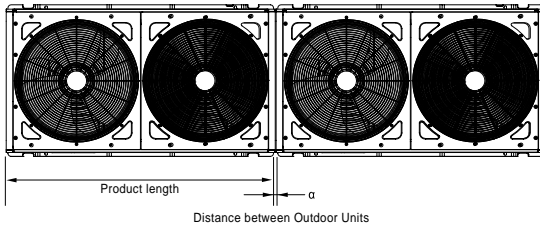

Refrigerant piping system

◆ Y branch method

Example : 5 indoor units connected

- Ⓐ : Outdoor unit
- Ⓑ : 1st branch (Y branch)
- Ⓒ : Indoor units

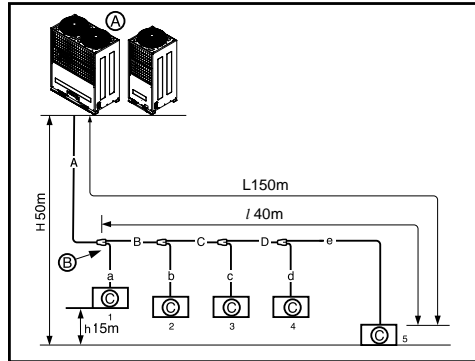

Example : 5 indoor units connected

- Ⓐ : Outdoor unit
- Ⓑ : 1st branch (Y branch)
- Ⓒ : indoor units
- Ⓓ : Connection branch pipe between outdoor units: ARCNN30
- Ⓔ : Connection branch pipe between outdoor units: ARCNN20

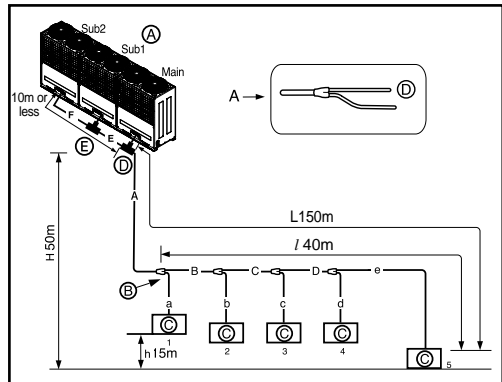

**CAUTION**

Piping length from outdoor branch to outdoor unit  $\leq 10\text{m}$ , equivalent length: max 13m (for 16HP or more)

**○ Refrigerant pipe diameter from branch to branch (B,C,D)**

Downward indoor unit total capacity [kW(Btu/h)]	Liquid pipe [mm(inch)]	Gas pipe [mm(inch)]
< 22.4(76,400)	Ø9.52(3/8)	Ø15.88(5/8)
< 33(112,600)	Ø9.52(3/8)	Ø22.2(7/8)
< 47(160,400)	Ø12.7(1/2)	Ø28.58(1 1/8)
< 71(242,300)	Ø15.88(5/8)	Ø28.58(1 1/8)
< 104(354,900)	Ø19.05(3/4)	Ø34.9(1 3/8)
104(354,900) ≤	Ø19.05(3/4)	Ø41.3(1 5/8)

**○ Total pipe length = A+B+C+D+a+b+c+d+e ≤ 300m**

<b>L</b>	Longest pipe length	Equivalent pipe length
	A+B+C+D+e ≤ 150m	* A+B+C+D+e ≤ 175m
<b>l</b>	Longest pipe length after 1st branch	
	B+C+D+e ≤ 40m	
<b>H</b>	Difference in height(outdoor unit ↔ indoor unit)	
	H ≤ 50m ( 40m : outdoor unit is lower than indoor units)	
<b>h</b>	Difference in height (indoor unit ↔ indoor unit)	
	h ≤ 15m	

**⚠ CAUTION**

- \* : Assume equivalent piping length of Y branch to be 0.5m, that of header to be 1m, calculation purpose.

### ◆ Header Method

#### Example : 6 indoor units connected

- Ⓐ : Outdoor unit
- Ⓑ : 1st branch
- Ⓒ : Indoor units
- Ⓓ : Sealed piping

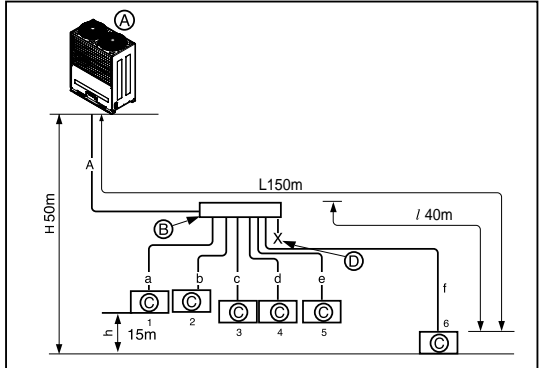

#### Example : 6 indoor units connected

- Ⓐ : Outdoor unit
- Ⓑ : 1st branch
- Ⓒ : Indoor unit
- Ⓓ : Sealed piping
- Ⓔ : Connection branch pipe between outdoor units: ARCNN30
- Ⓕ : Connection branch pipe between outdoor units: ARCNN20

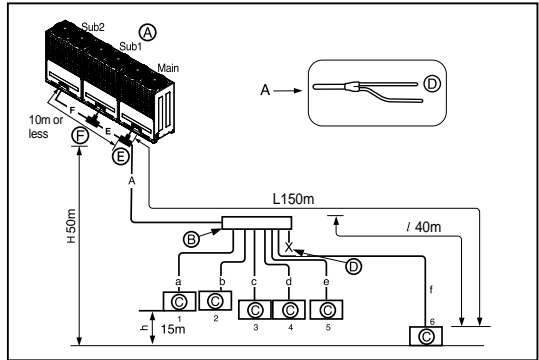

**Branch pipe can not be used after header**

○ Total pipe length =  $A+a+b+c+d+e+f \leq 300m$

L	Longest pipe length	* Equivalent pipe length
	$A+f \leq 150m$	$A+f \leq 175m$
l	Longest pipe length after 1st branch	
	$f \leq 40m$	
H	Difference in height(outdoor unit ↔ indoor unit)	
	$H \leq 50m$ (40m : outdoor unit is lower)**	
h	Difference in height (indoor unit ↔ indoor unit)	
	$h \leq 15m$	

### ⚠ WARNING

Pipe lengths after header branching (a~f)

It is recommended that difference in lengths of the pipes connected to the indoor units is minimized. Performance difference between indoor units may occur.

### ⚠ CAUTION

- \* : Assume equivalent piping length of Y branch to be 0.5m, that of header to be 1m, calculation purpose
- \*\* : Indoor unit should be installed at lower position than the header.
- Piping length from outdoor branch to outdoor unit  $\leq 10m$ , equivalent length : max 13m (for 16HP or more)

◆ **Combination of Y branch/header method**

**Example : 5 indoor units connected**

- Ⓐ : Outdoor unit
- Ⓑ : 1st branch (Y branch)
- Ⓒ : Y branch
- Ⓓ : Indoor unit
- Ⓔ : Header
- Ⓕ : Sealed piping

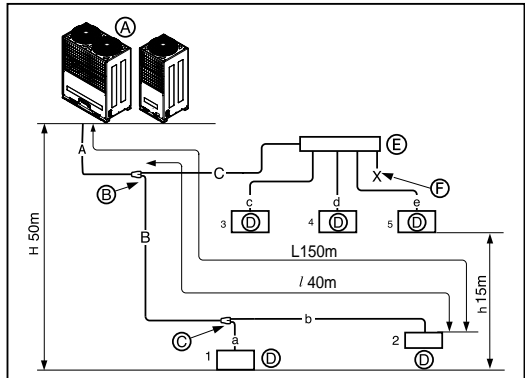

**Branch pipe can not be used after header**

**Example : 5 indoor units connected**

- Ⓐ : Outdoor unit
- Ⓑ : 1st branch
- Ⓒ : Y branch
- Ⓓ : Indoor unit
- Ⓔ : Connection branch pipe between outdoor units: ARCNN30
- Ⓕ : Connection branch pipe between outdoor units: ARCNN20
- Ⓖ : Header
- Ⓗ : Sealed piping

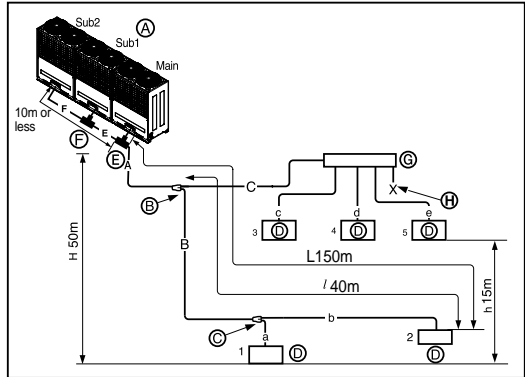

**Branch pipe can not be used after header**

### ○ Refrigerant pipe diameter from branch to branch (B,C)

Downward indoor unit total capacity [kW(Btu/h)]	Liquid pipe [mm(inch)]	Gas pipe [mm(inch)]
< 22.4(76,400)	Ø9.52(3/8)	Ø15.88(5/8)
< 33(112,600)	Ø9.52(3/8)	Ø22.2(7/8)
< 47(160,400)	Ø12.7(1/2)	Ø28.58(1 <sup>1</sup> / <sub>8</sub> )
< 71(242,300)	Ø15.88(5/8)	Ø28.58(1 <sup>1</sup> / <sub>8</sub> )
< 104(354,900)	Ø19.05(3/4)	Ø34.9(1 <sup>3</sup> / <sub>8</sub> )
104(354,900) ≤	Ø19.05(3/4)	Ø41.3(1 <sup>5</sup> / <sub>8</sub> )

### ○ Total pipe length = A+B+C+a+b+c+d+e ≤ 300m

<b>L</b>	Longest pipe length	* Equivalent pipe length
	A+B+b ≤ 150m	A+B+b ≤ 175m
<b>l</b>	Longest pipe length after 1st branch	
	B+b ≤ 40m	
<b>H</b>	Difference in height(outdoor unit ↔ indoor unit)	
	H ≤ 50m (40m : outdoor unit is lower than indoor units)**	
<b>h</b>	Difference in height (indoor unit ↔ indoor unit)	
	h ≤ 15m	



#### CAUTION

- \* : Assume equivalent pipe length of Y branch to be 0.5m, that of header to be 1m, calculation purpose
- \*\* : Indoor unit should be installed at lower position than the header



#### WARNING

It is recommended that difference of piping length connected to the indoor unit is minimized. Performance difference between indoor units may occur.

## ◆ Outdoor unit Connection

### ○ Refrigerant pipe diameter before 1st branch (A,E,F)

Upward outdoor unit total capacity [HP]	Liquid pipe [mm(inch)]	Gas pipe [mm(inch)]
5	Ø9.52(3/8)	Ø15.88(5/8)
6, 8	Ø9.52(3/8)	Ø19.05(3/4)
10	Ø9.52(3/8)	Ø22.2(7/8)
12~16	Ø12.7(1/2)	Ø28.58(1 <sup>1</sup> / <sub>8</sub> )
18~22	Ø15.88(5/8)	Ø28.58(1 <sup>1</sup> / <sub>8</sub> )
24	Ø15.88(5/8)	Ø34.9(1 <sup>3</sup> / <sub>8</sub> )
26~34	Ø19.05(3/4)	Ø34.9(1 <sup>3</sup> / <sub>8</sub> )
36~40	Ø19.05(3/4)	Ø41.3(1 <sup>5</sup> / <sub>8</sub> )

\* High/low pressure common pipe: Ø19.05(16HP or more)

### WARNING

Do not choose the main pipe diameter, namely A, by downward indoor unit total capacity but its outdoor unit model name. Do not let the connection pipe from branch to branch exceed the main pipe diameter chosen by outdoor unit model name. EX) Where connecting the indoor units to the 22 HP (61.5 kW) outdoor unit to 120% of its system capacity (73.8 kW) and branching 7k (2.1kW) indoor unit at the 1st branch

Main pipe diameter(22 HP outdoor unit): Ø28.58(gas pipe) Ø15.88(liquid pipe)

Pipe diameter between 1st and 2nd branch (71.7kW indoor units): Ø34.9(gas pipe) Ø19.05(liquid pipe) in conformity with downward indoor units.

Since the main pipe diameter of 22HP outdoor unit is Ø28.58(gas pipe) and Ø15.88(liquid pipe), it should be used as the main pipe and the connection pipe between 1st and 2nd indoor branches.

### WARNING

When the equivalent length between the outdoor unit and a indoor unit is 90 m or more, the size of main pipes (liquid pipe and gas pipe) must be increased one grade.

#### Gas pipe

5HP	.....Ø15.88 → Ø19.05
6, 8HP	.....Ø19.05 → Ø22.2
10HP	.....Ø22.2 → Ø25.4
12, 14HP	.....Ø28.58 → Not increased
16, 18, 20, 22HP	.....Ø28.58 → Ø31.8
24HP	.....Ø34.9 → Not increased
26, 28, 30, 32, 34HP	.....Ø34.9 → Ø38.1
36, 38, 40HP	.....Ø41.3 → Not increased

#### Liquid pipe

5, 6HP	.....Ø9.52 → Not increased
8, 10HP	.....Ø9.52 → Ø12.7
12, 14, 16HP	.....Ø12.7 → Ø15.88
18, 20, 22, 24HP	.....Ø15.88 → Ø19.05
26, 28, 30, 32, 34, 36, 38, 40HP	.....Ø19.05 → Ø22.2

## ◆ Indoor unit Connection

### ○ Indoor unit connecting pipe from branch (a,b,c,d,e,f)

indoor unit capacity [kW(Btu/h)]	Liquid pipe [mm(inch)]	Gas pipe [mm(inch)]
< 5.6(19,100)	Ø6.35(1/4)	Ø12.7(1/2)
< 16.0(54,600)	Ø9.52(3/8)	Ø15.88(5/8)
< 22.4(76,400)	Ø9.52(3/8)	Ø19.05(3/4)

## ◆ The Amount of Refrigerant

The calculation of the additional charge should take account of the length of pipe.

(A)	Product charge(1unit)=8kg	
(B)	Additional charge (kg)	
=	Total liquid pipe (m): Ø22.2mm	x 0.354(kg/m)
+	Total liquid pipe (m): Ø19.05mm	x 0.266(kg/m)
+	Total liquid pipe (m): Ø15.88mm	x 0.173(kg/m)
+	Total liquid pipe (m): Ø12.7mm	x 0.118(kg/m)
+	Total liquid pipe (m): Ø9.52mm	x 0.061(kg/m)
+	Total liquid pipe (m): Ø6.35mm	x 0.022(kg/m)
+	CF(kg) (Correction factor)	
	Total amount(kg)	= (A) + (B)

**CAUTION** If a negative result is obtained from the calculation, no refrigerant needs to be added.

**(A)** Outdoor Unit  
**(B)** Indoor Unit  
 A : ø9.52, 40m  
 B : ø9.52, 20m  
 C : ø9.52, 20m  
 a : ø6.35, 10m  
 b : ø6.35, 10m  
 c : ø6.35, 10m  
 d : ø6.35, 10m  
 e : ø6.35, 10m

Additional Charge = A x 0.061 + B x 0.061 + C x 0.061 + (a+b+c+d+e) x 0.022 + CF  
 = 40 x 0.061 + 20 x 0.061 + 20 x 0.061 + (10 x 5) x 0.022 - 0 (CF)  
 = 5.98(kg)

### WARNING

- ▶ Regulation for refrigerant leakage  
: the amount of refrigerant leakage should satisfy the following equation for human safety.

$$\frac{\text{Total amount of refrigerant in the system}}{\text{Volume of the room at which indoor unit of the least capacity is installed}} \leq 0.3 \text{ ( kg / m}^3 \text{)}$$

**□ If the above equation can not be satisfied, then follow the following steps.**

- Selection of air conditioning system: select one of the next
  1. Installation of effective opening part
  2. Reconfirmation of outdoor unit capacity and piping length
  3. Reduction of the amount of refrigerant
  4. Installation of 2 or more security device (alarm for gas leakage)
- Change indoor unit type  
: installation position should be over 2m from the floor (wall mounted type → cassette type)
- Adoption of ventilation system  
: choose ordinary ventilation system or building ventilation system
- Limitation in piping work  
: Prepare for earthquake and thermal stress

### WARNING

- ▶ Refer to model information since the CF value of correction factor differs depending on model.

## ◆ Distribution Method

### 1. Line Distribution

With line distribution method, it is possible to make the first and the second main pipe distribution within the third branch. Do not make the third main pipe distribution. Do not make the main pipe distribution at or after fourth branch.

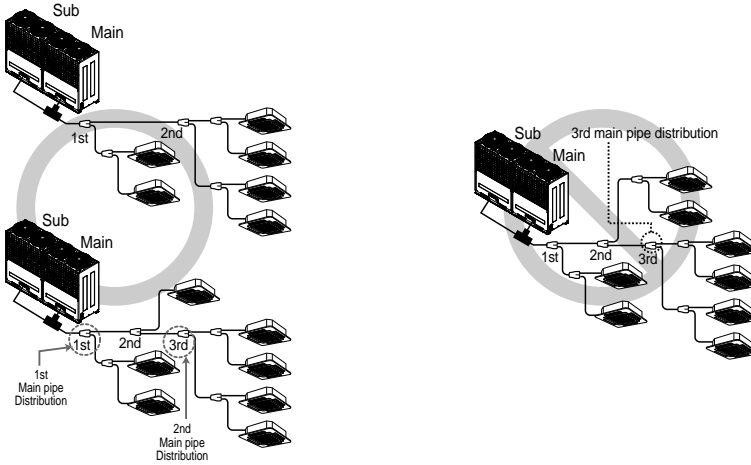

### 2. Vertical Distribution

Ensure that the branch pipes are attached vertically.

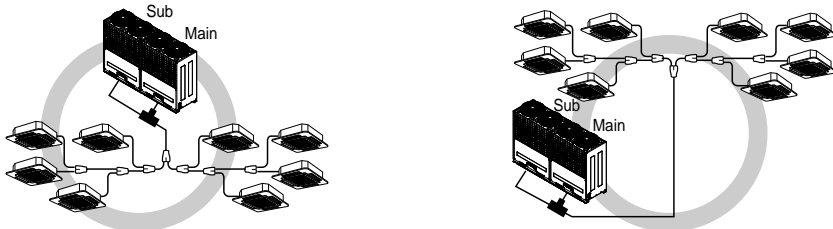

### 3. The others

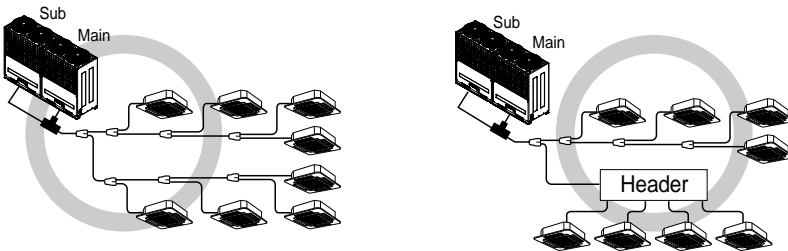

## Branch pipe Fitting

### ■ Y branch

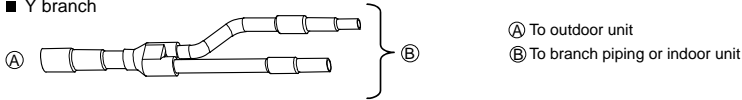

- Ensure that the branch pipes are attached horizontally or vertically (see the diagram below.)

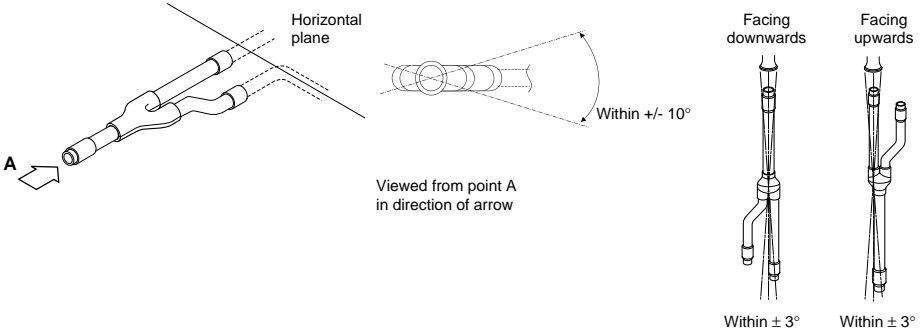

- There is no limitation on the joint mounting configuration.
- If the diameter of the refrigerant piping selected by the procedures described is different from the size of the joint, the connecting section should be cut with a pipe cutter.
- Branch pipe should be insulated with the insulator in each kit.

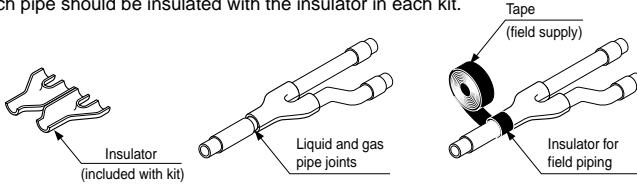

### ■ Header

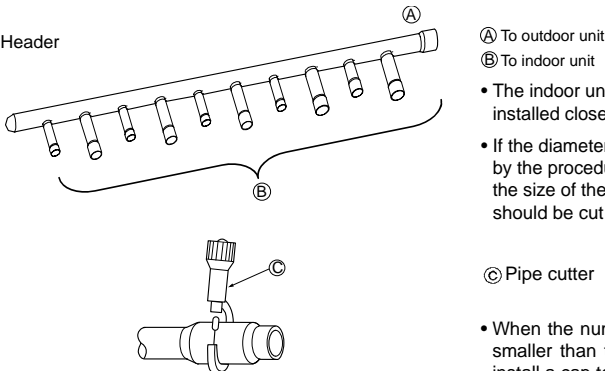

- The indoor unit having larger capacity must be installed closer to (A) than smaller one.
- If the diameter of the refrigerant piping selected by the procedures described is different from the size of the joint, the connecting section should be cut with a pipe cutter.

### (C) Pipe cutter

- When the number of pipes to be connected is smaller than the number of header branches, install a cap to the unconnected branches.

## Refrigerant piping installation

- When the number of indoor units to be connected to the branch pipes is less than the number of branch pipes available for connection then cap pipes should be fitted to the surplus branches.

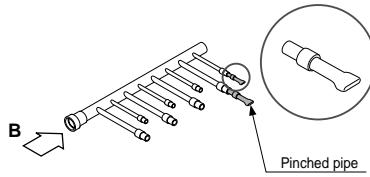

- Fit branch pipe lie in a horizontal plane.

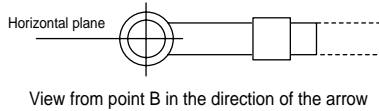

- Header should be insulated with the insulator in each kit.

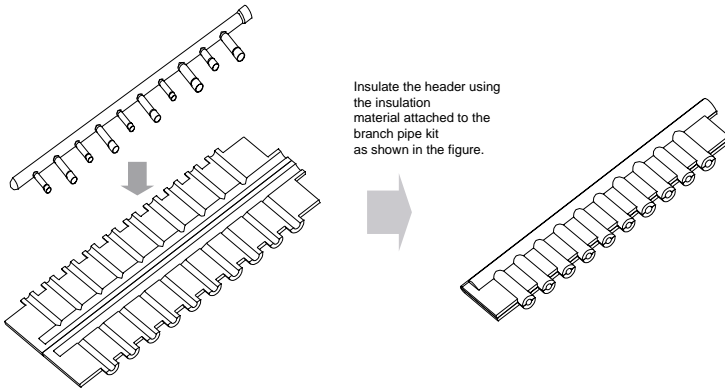

- Joints between branch and pipe should be sealed with the tape included in each kit.

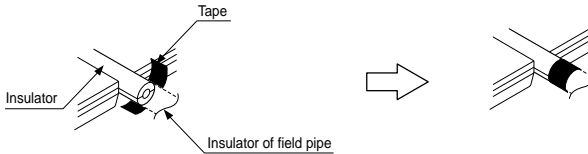

- Any cap pipe should be insulated using the insulator provided with each kit and then taped as described above.

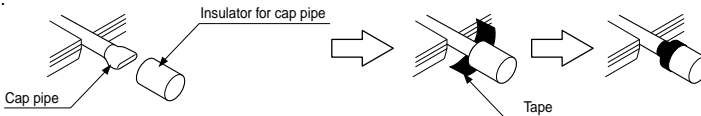

◆ Y branch pipe

[unit:mm]

ENGLISH

Models	Gas pipe	Liquid pipe
<p>ARBLN02220 ~ under 22.4kW</p>		
<p>ARBLN03320 ~ under 33.0kW</p>		
<p>ARBLN07120 ~ under 71.0kW</p>		
<p>ARBLN14520 71.0kW or more ~</p>		

◆ Header

[unit:mm]

Models	Gas pipe	Liquid pipe
4 branch ARBL054		
7 branch ARBL057		
4 branch ARBL104		
7 branch ARBL107		
10 branch ARBL1010		
10 branch ARBL2010		

## Leak Test and Vacuum drying

### (1) Leak test

Leak test should be made by pressurizing nitrogen gas to 3.8 MPa(38.7kgf/cm<sup>2</sup>). If the pressure does not drop for 24 hours, the system passes the test. If the pressure drops, check where the nitrogen leaks. For the test method, refer to the following figure. (Make a test with the service valves closed. Be also sure to pressurize liquid pipe, gas pipe and high/low pressure common pipe)

The test result can be judged good if the pressure has not been reduced after leaving for about one day after completion of nitrogen gas pressurization.

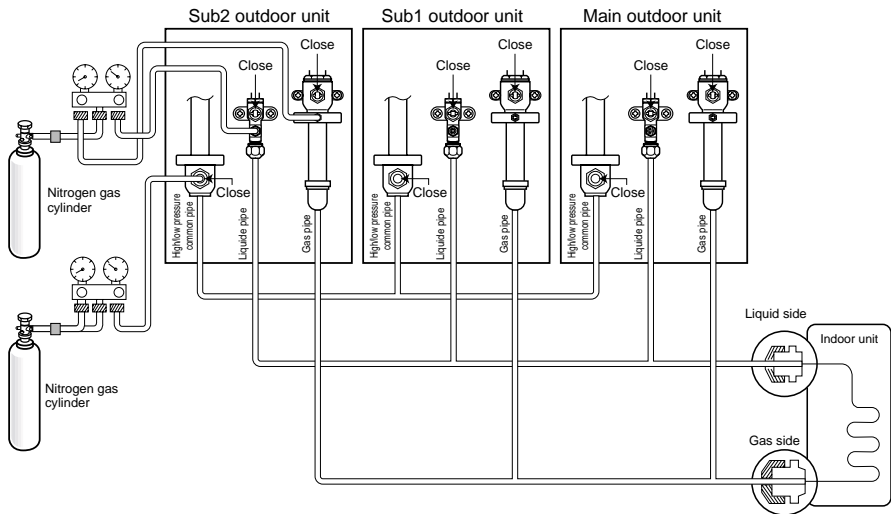

#### Note:

If the ambient temperature differs between the time when pressure is applied and when the pressure drop is checked, apply the following correction factor

There is a pressure change of approximately 0.1 kg/cm<sup>2</sup> (0.01 MPa) for each 1°C of temperature difference.

Correction= (Temp. at the time of pressurization – Temp. at the time of check) X 0.1

For example: Temperature at the time of pressurization (3.8 MPa) is 27 °C

24 hour later: 3.73 MPa, 20°C

In this case the pressure drop of 0.07 is because of temperature drop

And hence there is no leakage in pipe occurred.

#### Caution:

To prevent the nitrogen from entering the refrigeration system in the liquid state, the top of the cylinder must be at higher position than the bottom when you pressurize the system.

Usually the cylinder is used in a vertical standing position.

## (2) Vacuum

Vacuum drying should be made from the service port provided on the outdoor unit's service valve to the vacuum pump commonly used for liquid pipe, gas pipe and high/low pressure common pipe. (Make Vacuum from liquid pipe, gas pipe and high/low pressure common pipe with the service valve closed.)

\* Never perform air purging using refrigerant.

• Vacuum drying: Use a vacuum pump that can evacuate to -100.7kPa (5 Torr, -755mmHg).

1. Evacuate the system from the liquid and gas pipes with a vacuum pump for over 2 hrs and bring the system to -100.7kPa.  
After maintaining system under that condition for over 1 hr, confirm the vacuum gauge rises. The system may contain moisture or leak.
2. After evacuating the system for 2 hrs, give pressure to the system to 0.05MPa(vacuum break) with nitrogen gas and then evacuate it again with the vacuum pump for 1hr to -100.7kPa(vacuum drying). If the system cannot be evacuated to -100.7kPa within 2 hrs, repeat the steps of vacuum break and its drying. Finally, check if the vacuum gauge does not rise or not, after maintaining the system in vacuum for 1 hr.

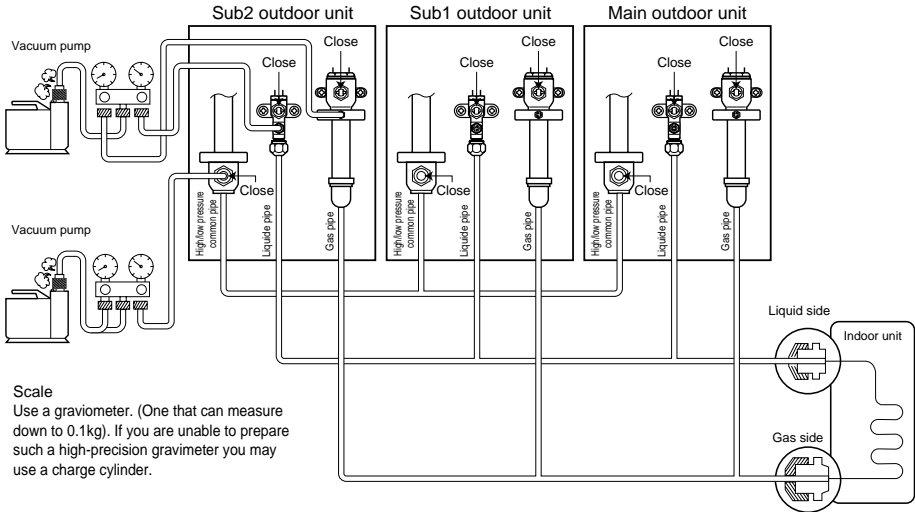

**Note :** Always add an appropriate amount of refrigerant. (For the refrigerant additional charge)  
Too much or too little refrigerant will cause trouble.

### **!** WARNING

**When installing and moving the air conditioner to another site, recharge after perfect evacuation.**

- If a different refrigerant or air is mixed with the original refrigerant, the refrigerant cycle may malfunction and the unit may be damaged.

## Thermal insulation of refrigerant piping

Be sure to give insulation work to refrigerant piping by covering liquid pipe and gas pipe separately with enough thickness heat-resistant polyethylene, so that no gap is observed in the joint between indoor unit and insulating material, and insulating materials themselves. When insulation work is insufficient, there is a possibility of condensation drip, etc. Pay special attention to insulation work to ceiling plenum.

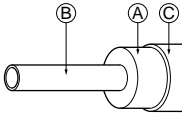

- (A) Heat insulation material
- (B) Pipe
- (C) Outer covering  
(Wind the connection part and cutting part of heat insulation material with a finishing tape.)

Heat insulation material	Glass fiber	
	Adhesive + Heat - resistant polyethylene foam + Adhesive tape	
Outer covering	Indoor	Vinyl tape
	Floor exposed	Water-proof hemp cloth + Bronze asphalt
	Outdoor	Water-proof hemp cloth + Zinc plate + Oily paint

**Note:**  
When using polyethylene cover as covering material, asphalt roofing shall not be required.

Bad example	<ul style="list-style-type: none"> <li>Do not insulate gas or low pressure pipe and liquid or high pressure pipe together.</li> </ul> <ul style="list-style-type: none"> <li>(A) Liquid pipe</li> <li>(B) Gas pipe</li> <li>(C) Power lines</li> <li>(D) Finishing tape</li> <li>(E) Insulating material</li> <li>(F) Transmission lines</li> </ul>	<ul style="list-style-type: none"> <li>Be sure to fully insulate connecting portion.</li> </ul> <p>(A) These parts are not insulated.</p>
	Good example	<ul style="list-style-type: none"> <li>(A) Liquid pipe</li> <li>(B) Gas pipe</li> <li>(C) Power lines</li> <li>(D) Insulating material</li> <li>(E) Transmission lines</li> </ul> <p>Power lines      Transmission lines</p> <p>Separation</p>

### Penetrations

Inner wall (concealed)

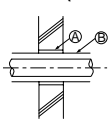

Outer wall

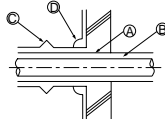

Outer wall (exposed)

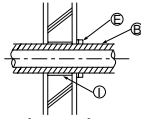

Floor (fireproofing)

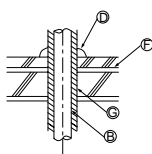

Roof pipe shaft

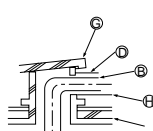

Penetrating portion on fire limit and boundary wall

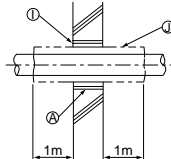

- (A) Sleeve
- (B) Heat insulating material
- (C) Lagging
- (D) Caulking material
- (E) Band
- (F) Waterproofing layer
- (G) Sleeve with edge
- (H) Lagging material
- (I) Mortar or other incombustible caulking
- (J) Incombustible heat insulation material

When filling a gap with mortar, cover the penetration part with steel plate so that the insulation material will not be caved in. For this part, use incombustible materials for both insulation and covering. (Vinyl covering should not be used.)

# Electrical Wiring

## Areas of Caution

1. Follow ordinance of your governmental organization for technical standard related to electrical equipment, wiring regulations and guidance of each electric power company.



### WARNING

Be sure to have authorized electric engineers do electric work using special circuits in accordance with regulations and this installation manual. If power supply circuit has a lack of capacity or electric work deficiency, it may cause an electric shock or fire.

2. Install the outdoor unit transmission line away from the power source wiring so that it may not be affected by electric noise from the power source. (Do not run it through the same conduit.)
3. Be sure to provide designated grounding work to outdoor unit.



### CAUTION

Be sure to put outdoor unit to earth. Do not connect earth line to any gas pipe, water pipe, lightning rod or telephone earth line. If earth is incomplete, it may cause an electric shock.

4. Give some allowance to wiring for electrical part box of indoor and outdoor units, because the box is sometimes removed at the time of service work.
5. Never connect the main power source to terminal block of transmission line. If connected, electrical parts will be burnt out.
6. Use 2-core shield cable for transmission line. (O mark in the figure below) If transmission lines of different systems are wired with the same multicore cable, the resultant poor transmitting and receiving will cause erroneous operations. (⊗ mark in the figure below)
7. Only the transmission line specified should be connected to the terminal block for outdoor unit transmission.

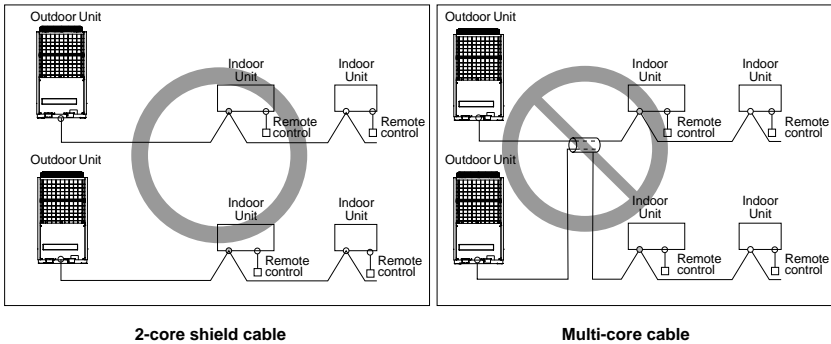

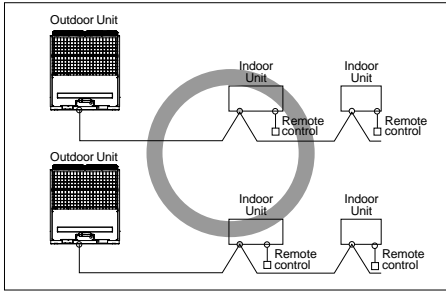

2-Core Shield Cable

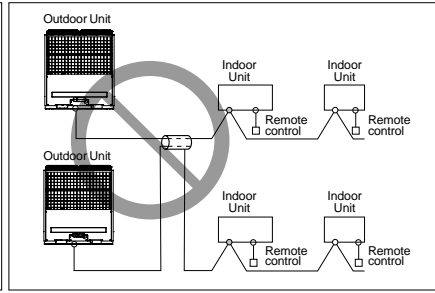

Multi-Core Cable

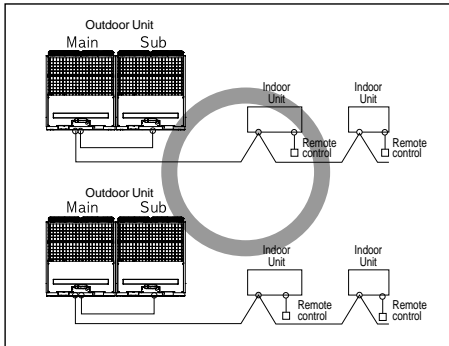

2-Core Shield Cable

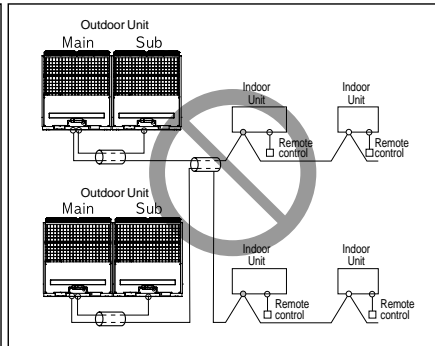

Multi-Core Cable

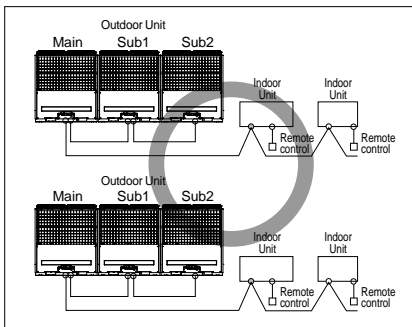

2-Core Shield Cable

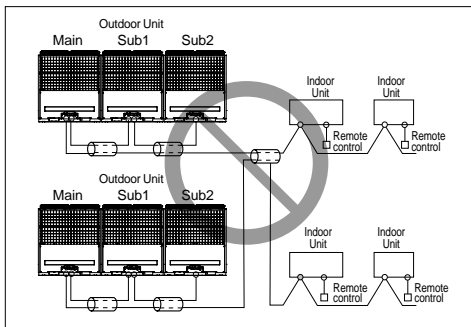

Multi-Core Cable

**⚠ WARNING**

- Use the 2-core shield cables for transmission lines. Never use them together with power cables.
- Never use multi-core cable
- As this unit is equipped with an inverter, to install a phase leading capacitor not only will deteriorate power factor improvement effect, but also may cause capacitor abnormal heating. Therefore, never install a phase leading capacitor.
- Keep power unbalance within 2% of the supply rating. Large unbalance will shorten the life of the smoothing capacitor.

## Control box and connecting position of wiring

- Remove all of the screws at front panel and remove the panel by pulling it forward.

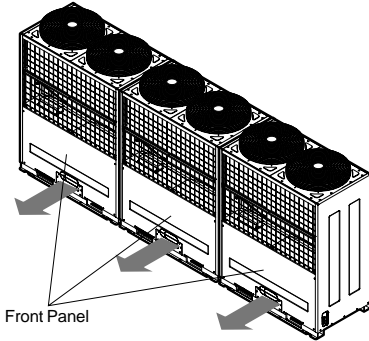

- Connect transmission line between main and sub outdoor unit through the terminal block.
- Connect transmission lines between outdoor unit and indoor units through the terminal block.
- When the central control system is connected to the outdoor unit, a dedicated PCB must be connected between them.
- When connecting transmission line between outdoor unit and indoor units with shielded wire, connect the shield ground to the earth screw.

### WARNING

The temperature sensor for outdoor air should not be exposed to direct sunlight.

- Provide an appropriate cover to intercept direct sunlight.

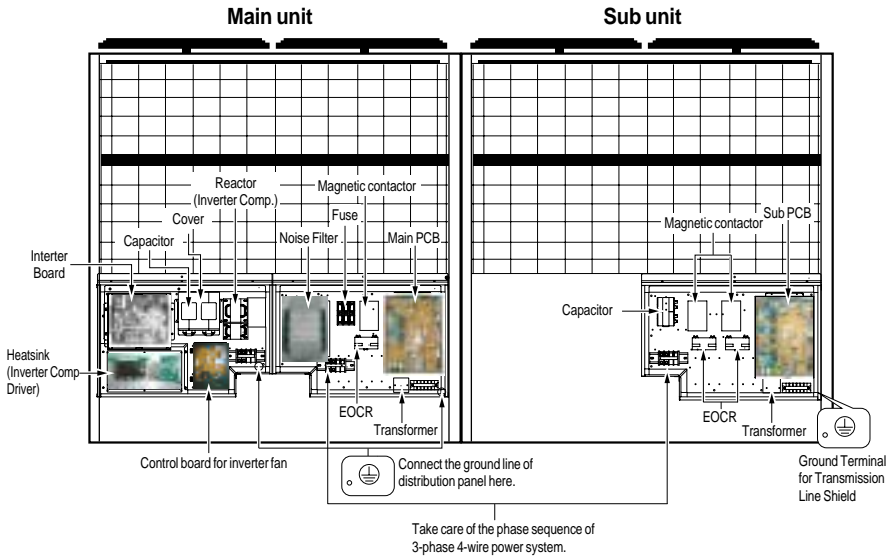

## Transmission and Power Lines

### 1) Transmission cable

- Types : shielding wire CVVS or CPEVS
- Diameter : over 0.75mm<sup>2</sup>
- Insulation material : PVC
- Maximum allowable temperature: 60°C
- Maximum allowable line length: under 220m

### 2) Remote control cable

- Types : 3-core cable

### 3) Simple central control cable

- Types : 4-core cable (Shielding wire)
- Diameter : over 0.75mm<sup>2</sup>
- Insulation material : PVC

### 4) Separation of transmission and power lines

- If transmission and power lines are run alongside each other then there is a strong likelihood of operational faults developing due to interference in the signal wiring caused by electrostatic and electromagnetic coupling.

The tables below indicates our recommendation as to appropriate spacing of transmission and power lines where these are to be run side by side

Current capacity of power line		Spacing
100V or more	10A	300mm
	50A	500mm
	100A	1000mm
	100A or more	1500mm

#### Note:

1. The figures are based on assumed length of parallel cabling up to 100m. For length in excess of 100m the figures will have to be recalculated in direct proportion to the additional length of line involved.
  2. If the power supply waveform continues to exhibit some distortion the recommended spacing in the table should be increased.
- If the lines are laid inside conduits then the following point must also be taken into account when grouping various lines together for introduction into the conduits
  - Power lines(including power supply to air conditioner) and signal lines must not be laid inside the same conduit
  - In the same way, when grouping the power lines and signal lines should not be bunched together.



#### CAUTION

- If apparatus is not properly earthed then there is always a risk of electric shocks, the earthing of the apparatus must be carried out by a qualified person.
- Use a power wire pipe for the power wiring.

## ◆ Wiring of Main Power Supply and Equipment Capacity

Outdoor unit ((3Ø, 380 ~415V, 50Hz)(3Ø, 380V, 60Hz)) indoor unit(1Ø, 220V, 50Hz)(1Ø, 220V, 60Hz)

Model	Minimum Wire Thickness(mm <sup>2</sup> )			Breaker for Wiring (NFB)	Breaker for Current Leakage(ELB)
	Main Cable	Branch	Ground		
1 outdoor unit(half size)	5.5	–	5.5	30A	30A 100mA 0.1 sec. or less
Indoor unit (all models)	2	2	2	25A	30A 30mA 0.1 sec. or less

Model	Minimum Wire Thickness(mm <sup>2</sup> )			Breaker for Wiring (NFB)	Breaker for Current Leakage(ELB)
	Main Cable	Branch	Ground		
1 outdoor unit	8	–	8	50A	50A 100mA 0.1 sec. or less
Indoor unit (all models)	4	2	4	30A	30A 30mA 0.1 sec. or less

Model	Minimum Wire Thickness(mm <sup>2</sup> )			Breaker for Wiring (NFB)	Breaker for Current Leakage(ELB)
	Main Cable	Branch	Ground		
2 outdoor units	14	–	14	75A	75A 100mA 0.1 sec. or less
Indoor unit (all models)	4	2	4	30A	30A 30mA 0.1 sec. or less

※ Power line between main outdoor unit and sub outdoor unit: 8mm<sup>2</sup>

Model	Minimum Wire Thickness(mm <sup>2</sup> )			Breaker for Wiring (NFB)	Breaker for Current Leakage(ELB)
	Main Cable	Branch	Ground		
3 outdoor units	38	–	38	110A	125A 200mA 0.1 sec. or less
Indoor unit (outdoor unit 3ØHP)	5.5	2	5.5	50A	50A 50mA 0.1 sec. or less
Indoor unit (outdoor unit 4ØHP)	8	2	8	60A	60A 60mA 0.1 sec. or less

※ Power line between main outdoor unit and sub outdoor unit: 14mm<sup>2</sup>

※ Power line between sub 1 outdoor unit and sub 2 outdoor unit: 8mm<sup>2</sup>.

1. Use a separate power supply for the outdoor unit and indoor unit.
2. Bear in mind ambient conditions (ambient temperature, direct sunlight, rain water, etc.) when proceeding with the wiring and connections.
3. The wire size is the minimum value for metal conduit wiring. The power cord size should be 1 rank thicker taking into account the line voltage drops. Make sure the power-supply voltage does not drop more than 10%.
4. Specific wiring requirements should adhere to the wiring regulations of the region.
5. Power supply cords of parts of appliances for outdoor use should not be lighter than polychloroprene sheathed flexible cord.
6. Don't install an individual switch or electrical outlet to disconnect each of indoor unit separately from the power supply.

### WARNING

- Follow ordinance of your governmental organization for technical standard related to electrical equipment, wiring regulations and guidance of each electric power company.
- Be sure to use specified wires for connections so that no external force is imparted to terminal connections. If connections are not fixed firmly, it may cause heating or fire.
- Be sure to use the appropriate type of overcurrent protection switch. Note that generated overcurrent may include some amount of direct current.

### CAUTION

- Some installation site may require attachment of an earth leakage breaker. If no earth leakage breaker is installed, it may cause an electric shock.
- Do not use anything other than breaker and fuse with correct capacity. Using fuse and wire or copper wire with too large capacity may cause a malfunction of unit or fire.

## ◆ Example Connection of Transmission Cable

### 1 Outdoor unit(Half size)

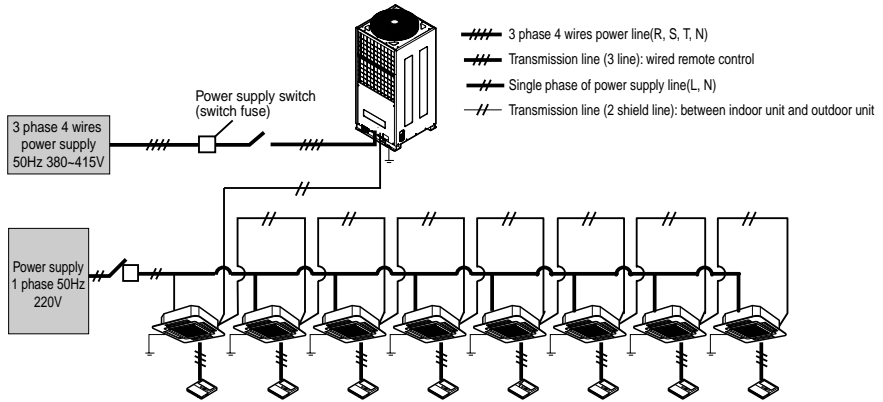

### ⚠ WARNING

- Indoor unit ground lines are required for preventing electrical shock accident in current leakage, transmission disorder by noise effect and motor current leakage (without connection to pipe).
- Don't install an individual switch or electrical outlet to disconnect each of indoor unit separately from the power supply.

Between indoor and main outdoor unit

Indoor unit		Outdoor unit		Central controller			
A	B	E	F	C	D	Vcc	GND

Main outdoor unit

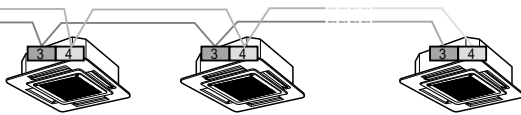

The GND terminal is a 'L' terminal for the central controller, not ground line

## ◆ Example Connection of Transmission Cable

### 1 Outdoor unit

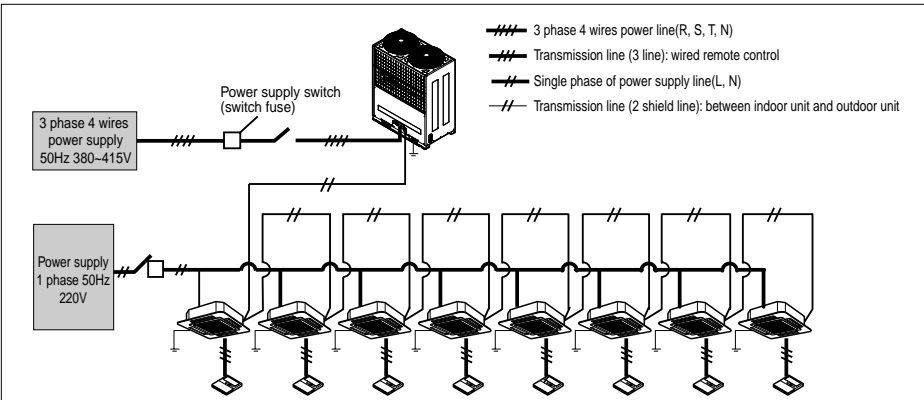

### ⚠ WARNING

- Indoor unit ground lines are required for preventing electrical shock accident in current leakage, transmission disorder by noise effect and motor current leakage (without connection to pipe).
- Don't install an individual switch or electrical outlet to disconnect each of indoor unit separately from the power supply.

Between indoor and main outdoor unit

Indoor unit		Outdoor unit		Central controller				Main outdoor unit
A	B	E	F	C	D	Vcc	GND	

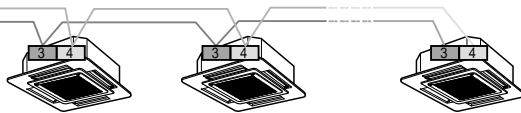

The GND terminal is a '-' terminal for the central controller, not ground line

## ◆ Example Connection of Transmission Cable

### 2 Outdoor units

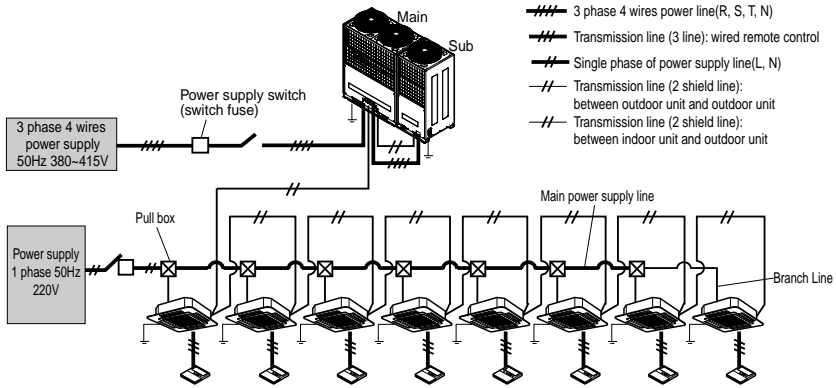

### ⚠ WARNING

- Indoor unit ground lines are required for preventing electrical shock accident in current leakage, transmission disorder by noise effect and motor current leakage (without connection to pipe).
- Don't install an individual switch or electrical outlet to disconnect each of indoor unit separately from the power supply.

Between Indoor and main outdoor unit

Indoor unit		Outdoor unit		Central controller				Main outdoor unit	
A	B	E	F	C	D	Vcc	GND		
[Indoor Unit]		[Outdoor Unit]		[Central Controller]				[Main Outdoor Unit]	

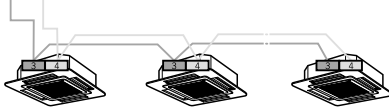

Between main outdoor and sub outdoor unit

Indoor unit		Outdoor unit		Central controller				Main outdoor unit	
A	B	E	F	C	D	Vcc	GND		
[Indoor Unit]		[Outdoor Unit]		[Central Controller]				[Main Outdoor Unit]	

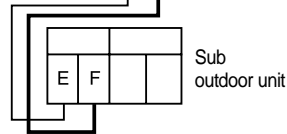

The GND terminal is a 'L' terminal for the central controller, not ground line

## ◆ Example Connection of Transmission Cable

### 2 Outdoor units

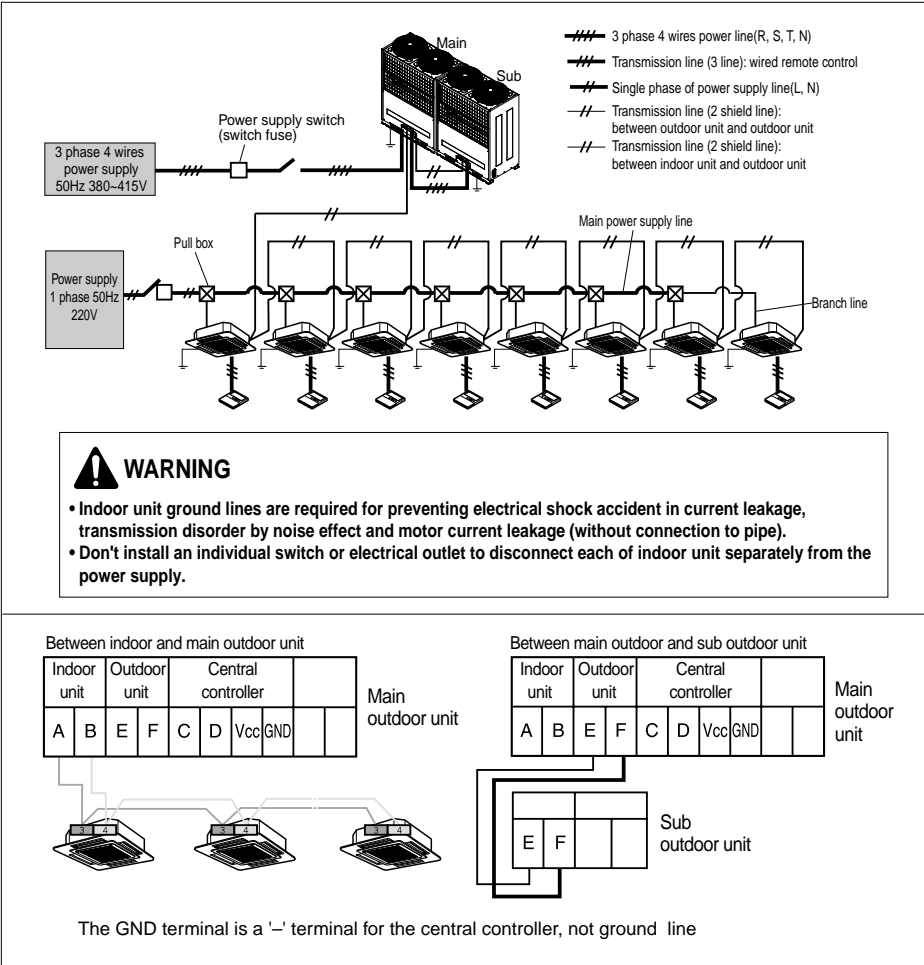

### ◆ Example Connection of Transmission Cable

#### 3 Outdoor units

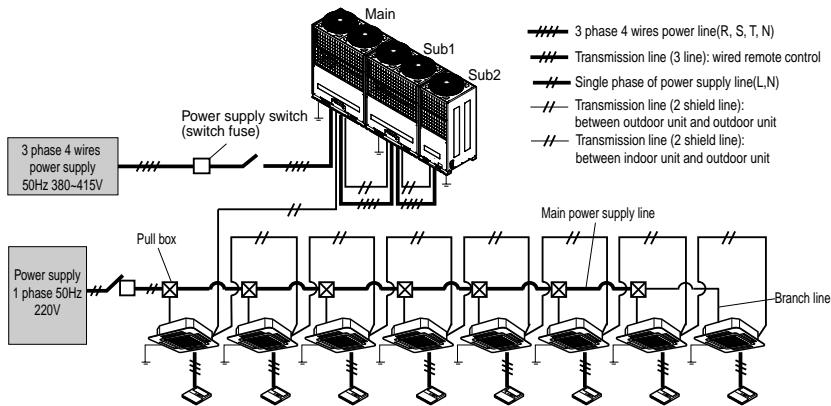

#### WARNING

- Indoor unit ground lines are required for preventing electrical shock accident in current leakage, transmission disorder by noise effect and motor current leakage (without connection to pipe).
- Don't install an individual switch or electrical outlet to disconnect each of indoor unit separately from the power supply.

Between indoor and main outdoor unit

Indoor unit		Outdoor unit		Central controller						Main outdoor unit
A	B	E	F	C	D	Vcc	GND			

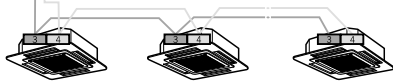

Between main outdoor and sub outdoor unit

Indoor unit		Outdoor unit		Central controller						Main outdoor unit
A	B	E	F	C	D	Vcc	GND			

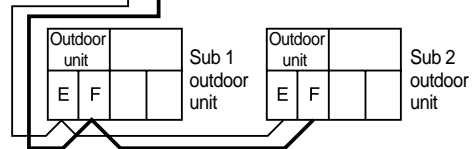

The GND terminal is a '-' terminal for the central controller, not ground line

## ◆ Example Connection of Transmission Cable

3 outdoor units

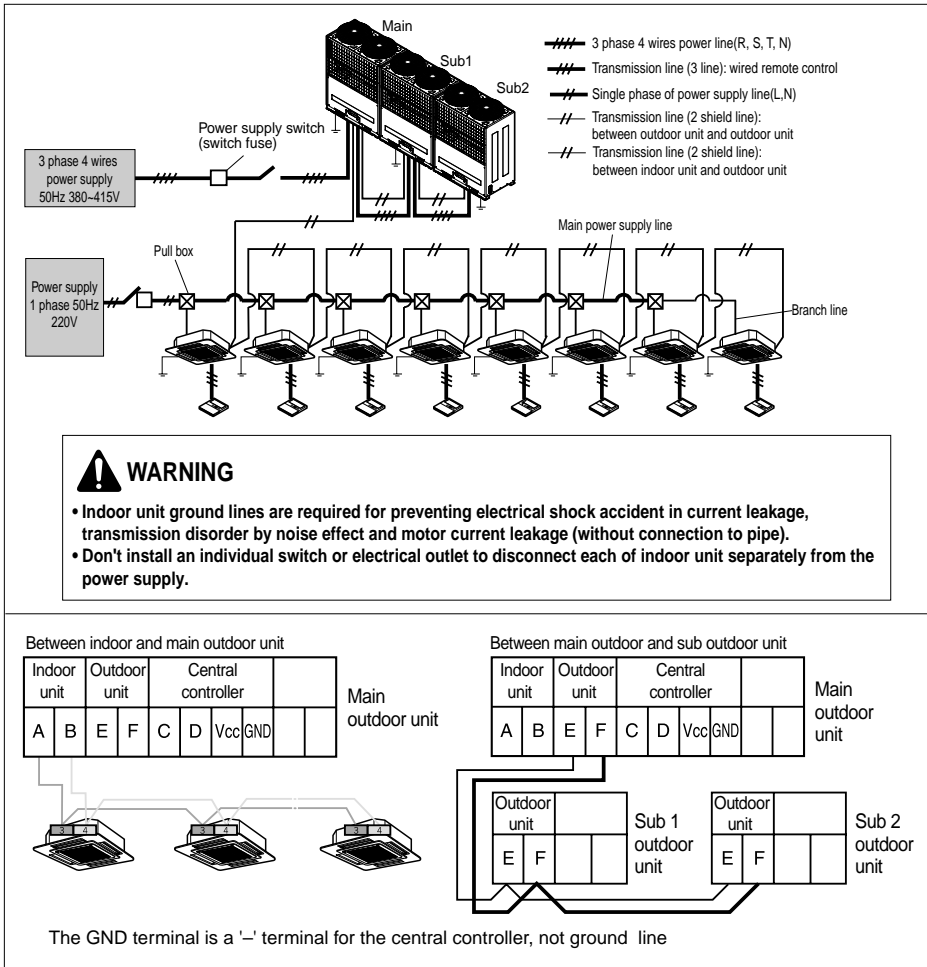

## ◆ Example Connection of Transmission Cable

### 1 Outdoor unit(Half size)

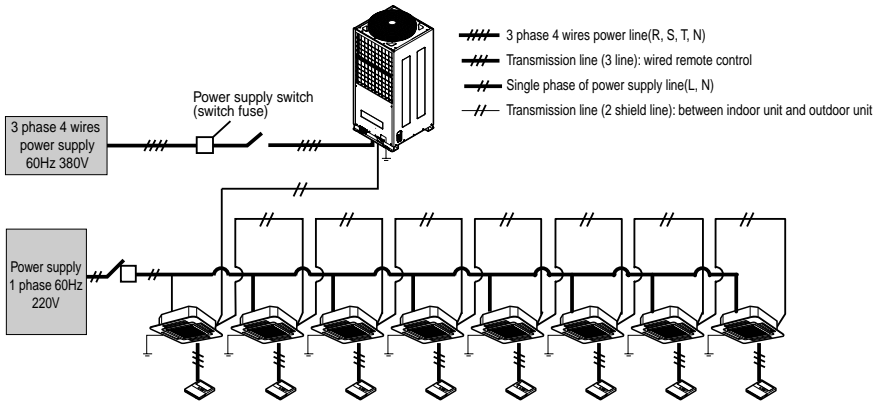

### ⚠ WARNING

- Indoor unit ground lines are required for preventing electrical shock accident in current leakage, transmission disorder by noise effect and motor current leakage (without connection to pipe).
- Don't install an individual switch or electrical outlet to disconnect each of indoor unit separately from the power supply.

Between indoor and main outdoor unit

Indoor unit		Outdoor unit		Central controller			
A	B	E	F	C	D	Vcc	GND

Main outdoor unit

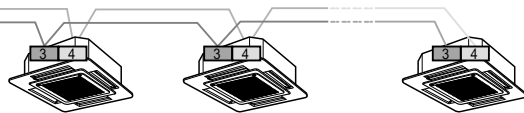

The GND terminal is a '—' terminal for the central controller, not ground line

## ◆ Example Connection of Transmission Cable

### 1 Outdoor unit

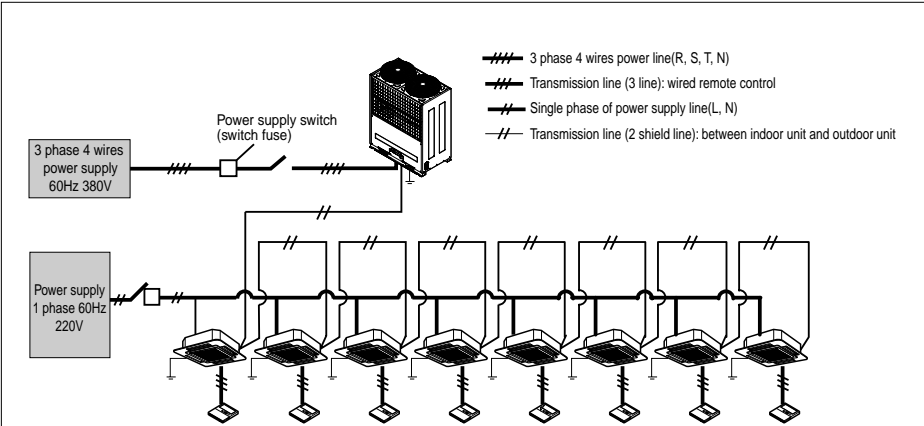

### WARNING

- Indoor unit ground lines are required for preventing electrical shock accident in current leakage, transmission disorder by noise effect and motor current leakage (without connection to pipe).
- Don't install an individual switch or electrical outlet to disconnect each of indoor unit separately from the power supply.

Between indoor and main outdoor unit

Indoor unit		Outdoor unit		Central controller					
A	B	E	F	C	D	Vcc	GND	Main outdoor unit	

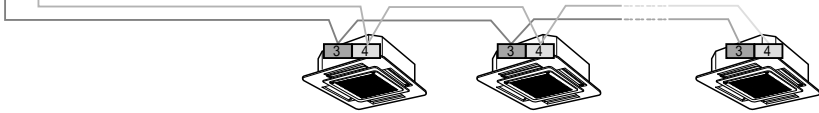

The GND terminal is a '-' terminal for the central controller, not ground line

### ◆ Example Connection of Transmission Cable

#### 2 Outdoor units

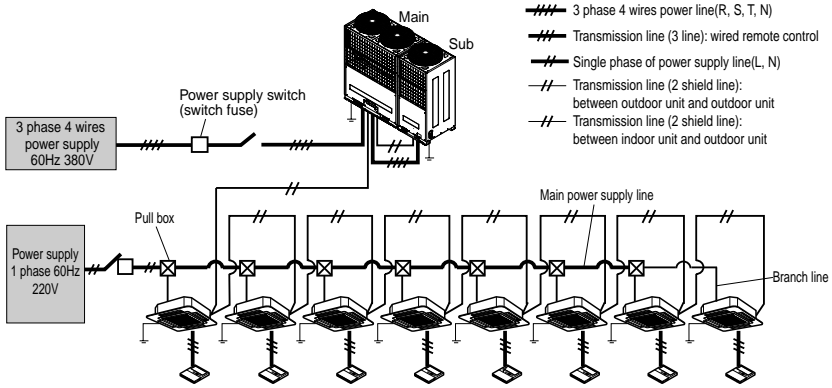

#### ⚠ WARNING

- Indoor unit ground lines are required for preventing electrical shock accident in current leakage, transmission disorder by noise effect and motor current leakage (without connection to pipe).
- Don't install an individual switch or electrical outlet to disconnect each of indoor unit separately from the power supply.

Between indoor and main outdoor unit

Indoor unit		Outdoor unit		Central controller			
A	B	E	F	C	D	Vcc	GND

main outdoor unit



Between main outdoor and sub outdoor unit

Indoor unit		Outdoor unit		Central controller			
A	B	E	F	C	D	Vcc	GND

Main outdoor unit

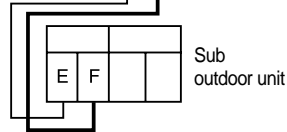

The GND terminal is a '-' terminal for the central controller, not ground line

## ◆ Example Connection of Transmission Cable

### 2 Outdoor units

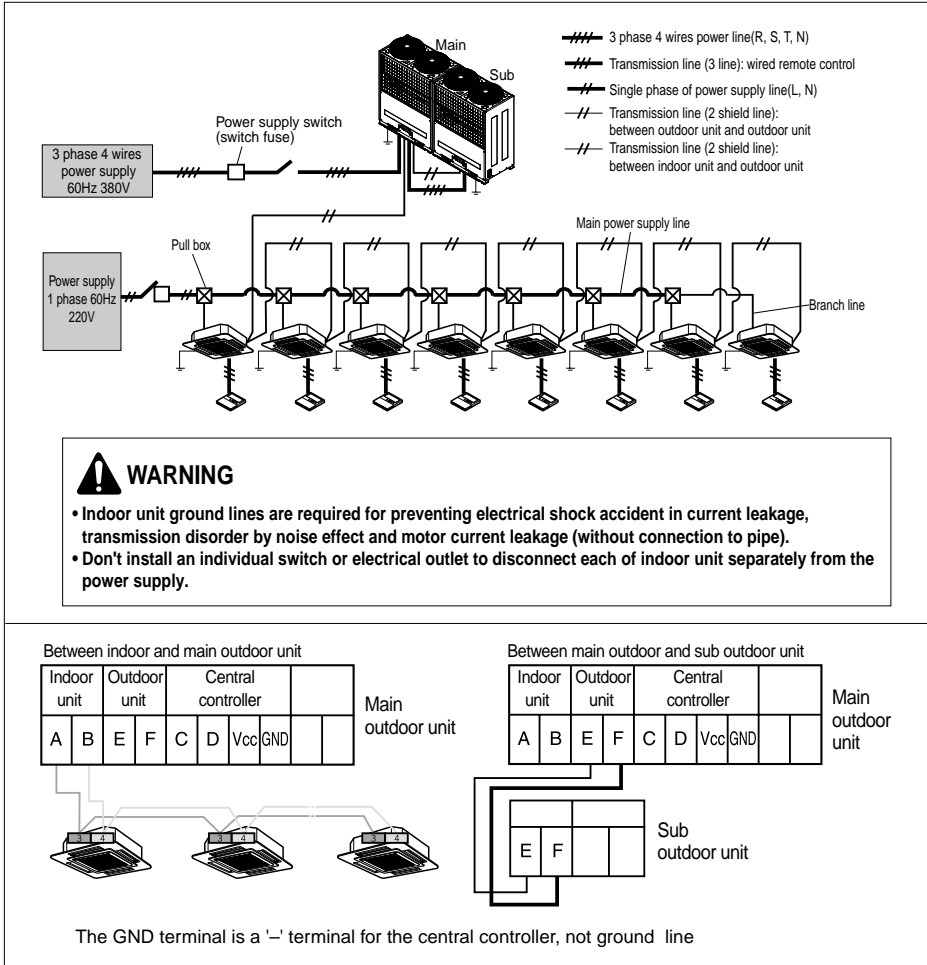

## ◆ Example Connection of Transmission Cable

### 3 Outdoor units

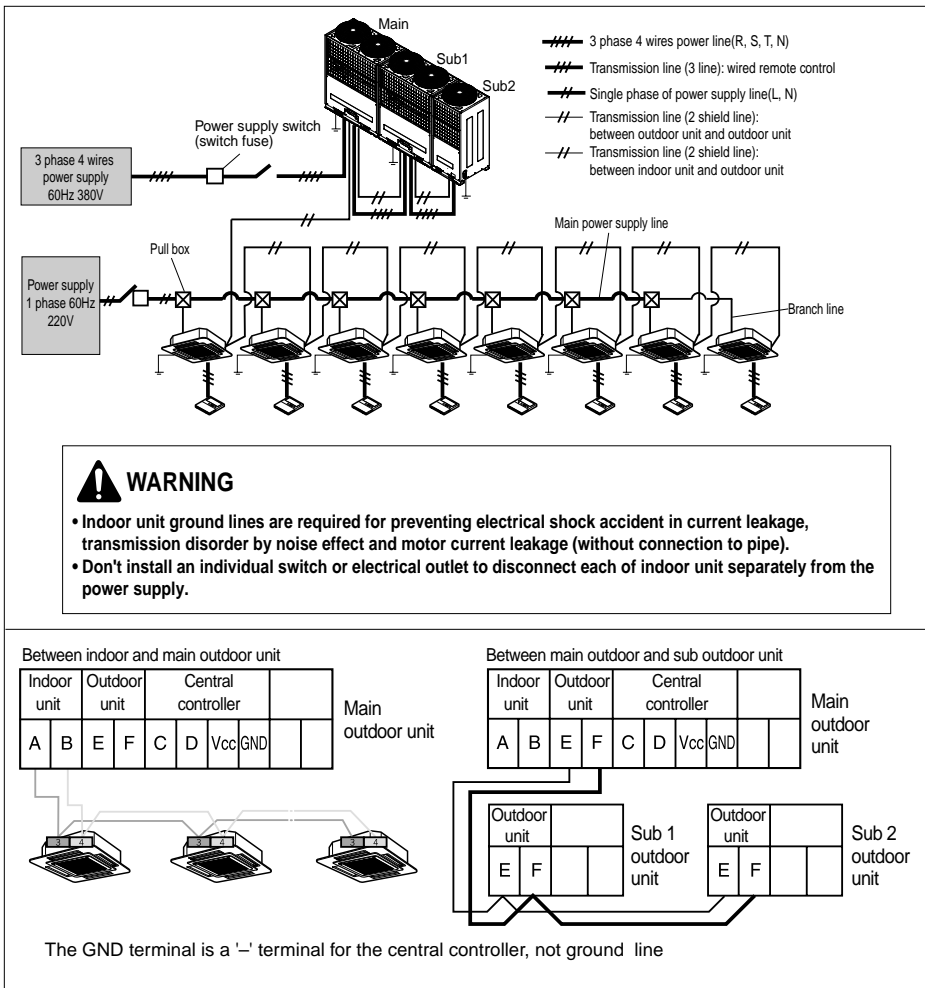

### ◆ Example Connection of Transmission Cable

#### 3 Outdoor units

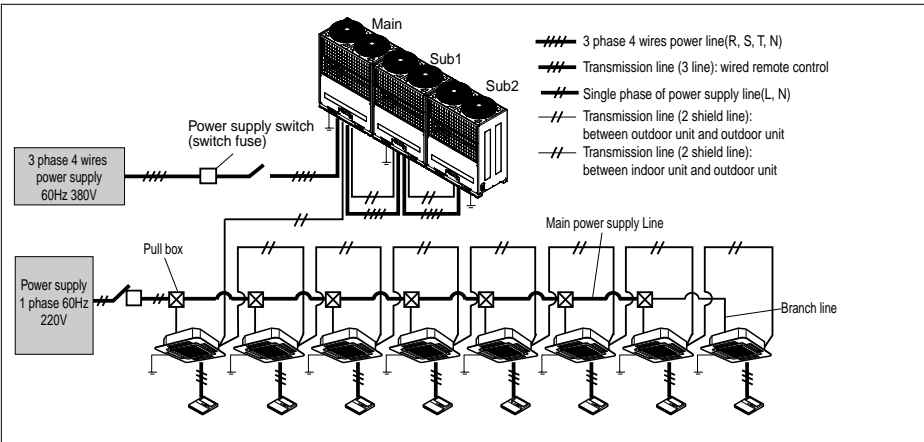

#### ⚠ WARNING

- Indoor unit ground lines are required for preventing electrical shock accident in current leakage, transmission disorder by noise effect and motor current leakage (without connection to pipe).
- Don't install an individual switch or electrical outlet to disconnect each of indoor unit separately from the power supply.

Between indoor and main outdoor unit

Indoor unit	Outdoor unit	Central controller				
A	B	E	F	C	D	Vcc GND

Main outdoor unit

Between main outdoor unit and sub outdoor unit

Indoor unit	Outdoor unit	Central controller				
A	B	E	F	C	D	Vcc GND

Main outdoor unit

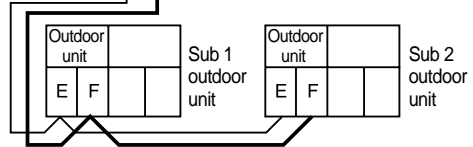

The GND terminal is a '-' terminal for the central controller, not ground line

**Location of setting Switch**

**Main PCB**

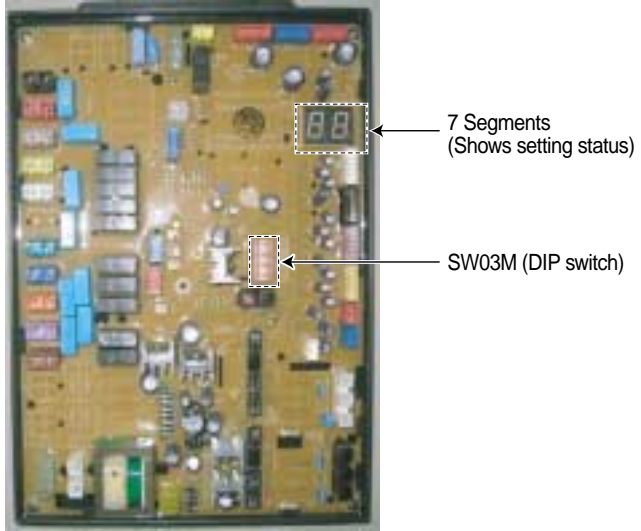

**Sub Unit PCB**

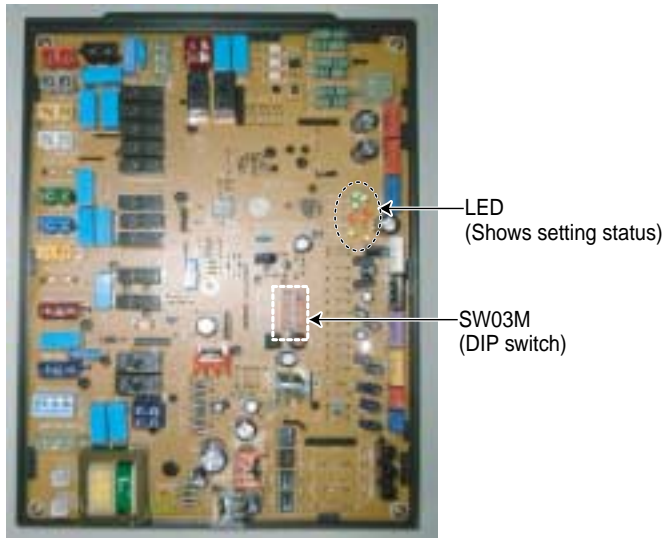

## DIP switch setting

### ■ Checking according to dip switch setting

1. You can check the setting values of the main outdoor unit from the 7 segment LED and those of the sub outdoor unit from the LED. The dip switch setting should be changed when the power is OFF.
2. It checks whether the input is properly performed without the bad contact of the dip switch or not

### ■ Checking the setting of the main unit

The number is sequentially appeared at the 7 segment in 5 seconds after applying the power. This number represents the setting condition. (For example, represents R410A 30HP) Main model code → Sub1 model code → Sub2 model code → total capacity → 1 → 25 → 41

1 ~255 : Main model code  
 1 ~255 : Sub1 model code  
 1 ~255 : Sub2 model code } Refer to table code

5~40 : HP number(sum of main capacity and sub capacity)  
 0 : cooling only            1 : heat pump  
 25 : normal                31 : data display  
 22 : R22 model            41 : R410A model

### ■ Checking the setting of the sub unit

It is displayed by 8 LED of the sub unit. A set of two LED's represents 0, 1, 2 and 3 in binary. LED1, LED3, LED5, and LED7 are least significant bit of each digit. LED2, LED4, LED6, and LED8 are most significant bit of each digit.

- 1) LED2, LED1  
 00 : 8HP unit,    01 : 10HP unit,    10 : 12HP unit,    11 : 14HP unit
- 2) LED4, LED3  
 10 : default
- 3) LED6, LED5  
 00 : -            01 : sub1            10: sub2            11 : sub3
- 4) LED8, LED7  
 00 : normal        11 : data display



### CAUTION

Product may not properly operate if the relevant DIP switch is not properly setup.

### Model Code

Model Code	Hz	Unit (HP)	Unit	Ref.
60	50	5	MAIN	410A
61		6		
62		8		
63		10		
64		12		
65		14		

Model Code	Hz	Unit (HP)	Unit	Ref.
66	50	6	SUB	R410A
67		10		
68		12		
69		14		

## ■ Setting the DIP switch (SW03M)

- Set the dip switch with the power turned off. If you change the setting when the power is on, the changed setting is not applied immediately. The changed setting is applied at the moment that the power is on.
- Instant indoor unit checking, data display mode, and forced oil collecting operation are used when the units are running. If you don't have to use those functions after using them, restore the dip switch setting.

### 1. Settings of main outdoor unit

<b>1) Loss compensation: Standard mode(default)</b>	
	<ul style="list-style-type: none"> <li><input type="radio"/> Setting before applying the power</li> <li><input checked="" type="radio"/> When the installation condition is normal (almost all cases), use standard mode.</li> </ul>
<b>2) Loss compensation: Save mode</b>	
	<ul style="list-style-type: none"> <li><input type="radio"/> Setting before applying the power</li> <li><input checked="" type="radio"/> When the total pipe length is extremely short, use save mode.</li> </ul>
<b>3) Loss compensation: Capacity up</b>	
	<ul style="list-style-type: none"> <li><input type="radio"/> Setting before applying the power</li> <li><input checked="" type="radio"/> When the total pipe length is extremely long, use capacity up mode.</li> </ul>
<b>4) Instant indoor unit checking: Cooling mode</b>	<p>With dip switch setting as left side, push address(red) button 3 times in 3 sec. With data button, select the indoor unit that you want to turn on/off. Push address button for 3 sec, and the indoor unit will be turned on/off. After using, restore the dip switch setting.</p>
<b>5) Instant indoor unit checking: Heating mode</b>	<p>If you set the dip switch #1 and #2 off during the instant indoor checking mode, the mode is ended. After that, restore the dip switch setting.</p>
<b>6) Instant indoor unit checking: Restoring</b>	<p>If you set the dip switch #1 and #2 off during the instant indoor checking mode, the mode is ended. After that, restore the dip switch setting.</p>
	<ul style="list-style-type: none"> <li><input type="radio"/> data</li> <li><input checked="" type="radio"/> address</li> </ul>

**7) Mode locking: Cooling mode locking**

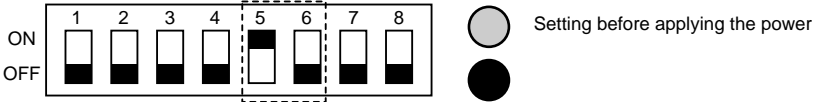

**8) Mode locking: Heating mode locking**

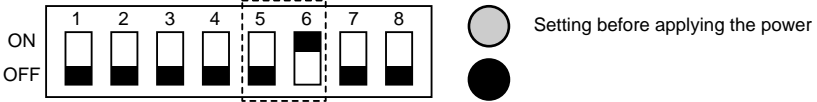

**9) Backup operation: constant speed comp. 1 backup**

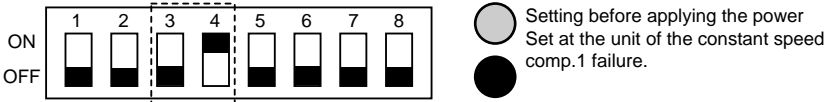

**10) Backup operation: unit backup**

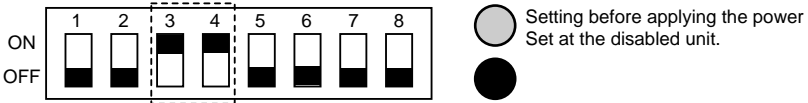

## 2. Settings of sub outdoor unit

### 1) The sequence of sub unit : 1<sup>st</sup> sub unit

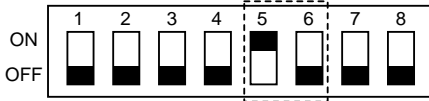

- At the 1<sup>st</sup> sub unit, set dip switch as the left side.
- Setting before applying the power.

### 2) The sequence of sub unit : 2<sup>nd</sup> sub unit

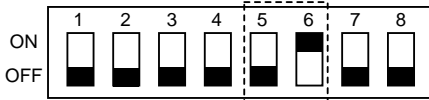

- At the 2<sup>nd</sup> sub unit, set dip switch as the left side.
- Setting before applying the power.

### 3) The sequence of sub unit : 3<sup>rd</sup> sub unit

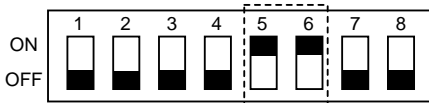

- At the 3<sup>rd</sup> sub unit, set dip switch as the left side.
- Setting before applying the power.

### 4) Backup operation: constant speed comp. 1 backup

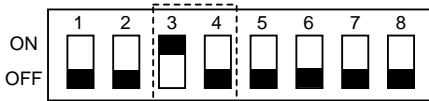

- Setting before applying the power  
Set at the unit of the inverter(constant speed comp.1) failure
- In case of inverter compressor failure, backup operation is possible when 110k or more indoor units are ON.

### 5) Backup operation: constant speed comp. 2 backup

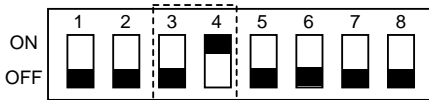

- Setting before applying the power  
Set at the unit of the constant speed comp.2 failure.
- 

### 6) Backup operation: unit backup

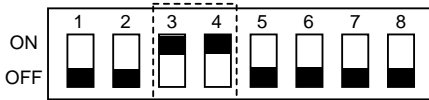

- Setting before applying the power  
Set at the disabled unit.
-

## Test Run

The test operation starts automatically by operating the DIP switch and buttons in the main unit as follows.

- (1) Before turning on the system, turn on the Dip switch No.7,8, turn on the No.1 Dip switch for cooling test and No.1,2 on for the heating test operation. After that, turn on the system.
- (2) If you turn on the No.7 and 8 DIP switch and press the black button for 2.5 seconds, you will see a character that looks like 'St' in the 7segment. When you turn both No. 7 and 8 off at this time, the test operation will start.
- (3) Turn on to operation mode with all indoor devices selected. (Strong wind mode, set temperature to 30°C for heating and 18°C for air conditioning)
- (4) When the compressor is normally operated with the operating logic, the target frequency will be 30Hz and when operated for more than 7 minutes after step (3), the unit will proceed to the next step.
- (5) Turn on one constant speed compressor, maintain the target frequency of the compressor to 40Hz and maintain this condition for 10 minutes. (for series)
- (6) Turn off the constant speed compressor that is on and at the same time turn on the other compressor.
- (7) Maintain the compressor that has been turned on newly in step (6).
- (8) Maintain all compressors on for 10 minutes until the rotational switching operation of turning on each compressor at a time is completed.
- (9) Proceed to the next stage when step (8) is completed.
- (10) Turn off the static speed compressor, wait 3 minutes and raise the target frequency of the compressor to 95Hz. This operation keeps about 7min.
- (11) Start the oil return operations.
- (12) When the oil return operation is completed, set the compressor frequency to 0 and maintain all indoor devices off for 5 minutes.
- (13) When step (12) is completed, it means that the test operation is completed. Turn off the No. 1, 2 of DIP switch in the main unit and must reset the system.
- (14) If there is any error during the operation, the error code will be shown in 7segment and the test operation will automatically end. (The error does not include poor operation of the static speed compressor and communication error from the indoor device.)

## Automatic Addressing

### • The address of indoor units would be set by automatic addressing

- 1) Wait for a 3 minutes after applying power supply (main and sub outdoor unit, indoor unit).
- 2) Press the switch of the outdoor unit (SW02M) for 5 seconds.
- 3) A "88" is indicated on 7-segment LED of the outdoor unit PCB.
- 4) For completing addressing, 2~7 minutes are required depending on numbers of indoor unit connection set.
- 5) Numbers of indoor unit connection set whose addressing is completed are indicated for 30seconds on 7-segment LED of the outdoor unit PCB.
- 6) After completing addressing, address of each indoor unit is indicated on the wired remote control display window. (CH01, CH02, CH03, ..... CH06: Indicated as numbers of indoor unit connection set.)

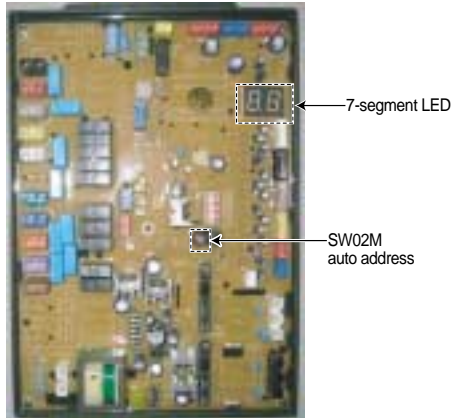

### CAUTION

- In replacement of the indoor unit PCB, always perform automatic address setting again. If power supply is not applied to the indoor unit, operation error occurs.
- Automatic addressing is only possible on the main PCB

## ◆ The Procedure of Automatic Addressing

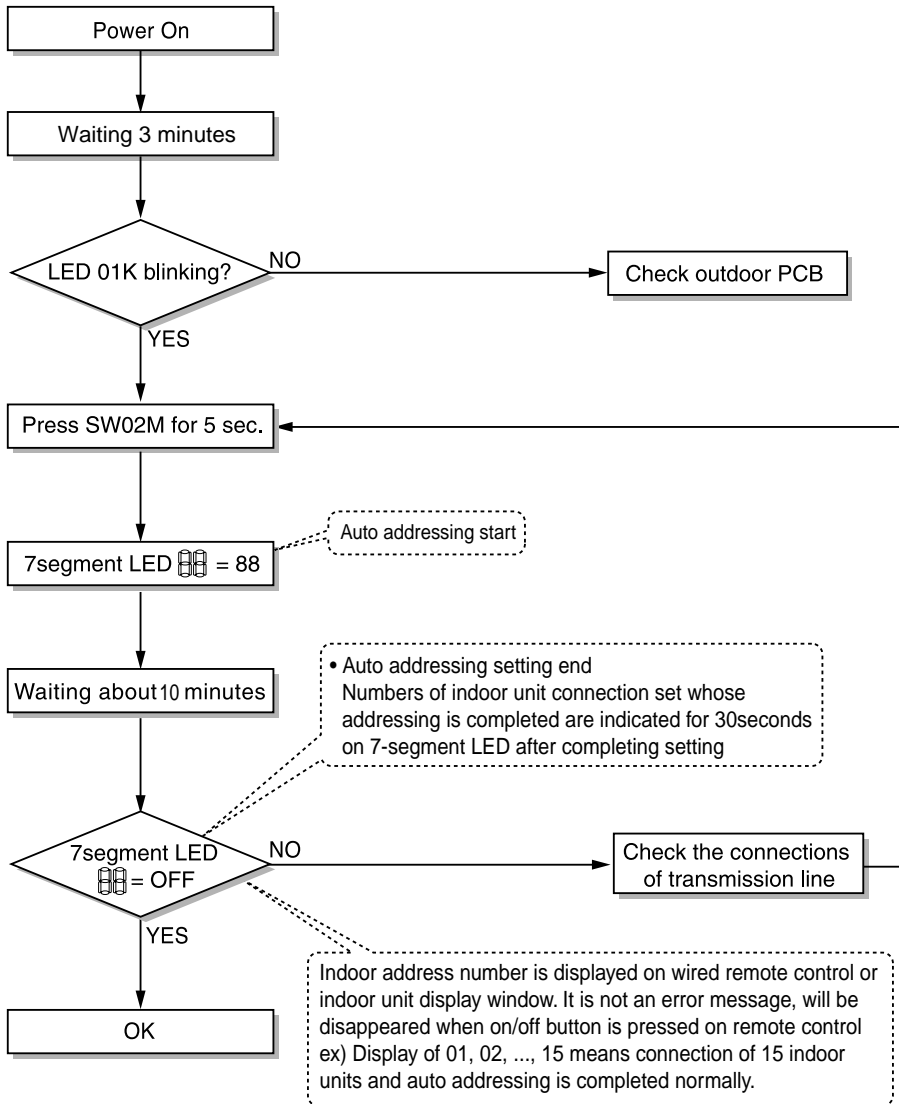

## Installation of Simple Central Controller

- ① Confirm the power of whole system(Indoor Unit, Outdoor Unit) is OFF, otherwise turn off.
- ② The transmission lines connected to C, D of simple central controller should be connected to C,D terminal port for central control of Outdoor Unit with care for their polarity (C → C, D → D)
- ③ Both the DC power (Vcc) and the GND connect the simple central controller according to the polarity of Vcc terminal and GND.
- ④ Turn the whole system on.
- ⑤ Set the group and Indoor Unit number with a wired remote control.
- ⑥ To control several sets of Indoor Units into a group, set the group ID from 0 to F for this purpose.

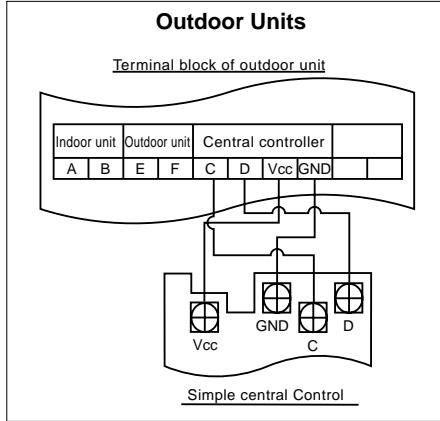

Group recognizing the simple central controller	
No.0 group (00~0F)	
No.1 group (10~1F)	
No.2 group (20~2F)	
No.3 group (30~3F)	
No.4 group (40~4F)	
No.5 group (50~5F)	
No.6 group (60~6F)	
No.7 group (70~7F)	
No.8 group (80~8F)	
No.9 group (90~9F)	
No. A group (A0~AF)	
No. B group (B0~BF)	
No. C group (C0~CF)	
No. D group (D0~DF)	
No. E group (E0~EF)	
No. F group (F0~FF)	

## Group Number Setting of Indoor Units

### • Using the wired remote controller

1. Press Program button and Set/Clr button at the same time for 3 seconds.
2. The current group and the indoor unit numbers are indicated on the "88" of the wired remote control.

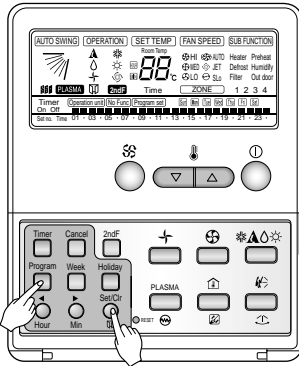

3. Set numbers by using the temperature adjust key.

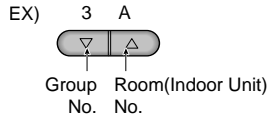

4. Press Program button and Set/Clr button at the same time for 3 seconds.
5. If transmit recognition data are received from the indoor unit, it returns to the general operation mode.

# Test Run

## Checks Before Test Run

1	Check to see whether there is any refrigerant leakage, and slack of power or transmission cable.
2	<p>Confirm that 500 V megger shows 2.0 MΩ or more between power supply terminal block and ground. Do not operate in the case of 2.0 MΩ or less.</p> <p>NOTE: Never carry out megaohm check over terminal control board. Otherwise the control board would be broken.</p> <p>Immediately after mounting the unit or after leaving it turned off for an extended length of time, the resistance of the insulation between the power supply terminal board and the ground may decrease to approx. 2 MΩ as a result of refrigerant accumulating in the internal compressor.</p> <p>If the insulation resistance is less than 2 MΩ, turning on the main power supply and energizing the crankcase heater for more than 6 hours will cause the refrigerant to evaporate, increasing the insulation resistance.</p>
3	<p>Check if high/low pressure common pipe, liquid pipe and gas pipe valves are fully opened.</p> <p>NOTE: Be sure to tighten caps.</p>
4	<p>Check if there are any problems in automatic addressing or not:</p> <p>Check and confirm that there are no error messages in the display of indoor units or remote controls and LED in outdoor units.</p>

### CAUTION

#### when cutting main power of the Multi V

- Always apply main power of the outdoor unit during use of product (cooling season/heating season).
- Always apply power before 6 hours to heat the crank case heater where performing test run after installation of product. It may result in burning out of the compressor if not preheating the crank case with the electrical heater for more than 6 hours. (In case of the outdoor temperature below 10°C)
- When operating the unit after powering off, automatically run into in the preheat mode for 3 hours and "PH" is indicated on the outdoor unit 7-Segment.

### CAUTION

#### Preheat of compressor

- Start preheat operation for 3 hours after supplying main power.
- 'PH' is indicated on the PCB LED during preheat of the compressor.
- Operation of the product during preheat operation is not possible, and operation is possible if 'PH' indication is disappeared after the compressor is fully preheated for 3 hours (preheat operation is performed for the outdoor temperature below 10°C).
- Preheat is only performed once after supplying power.
- Be sure to supply power 6 hours before operation so that the heater is heated (Insufficient heating may cause damage of the compressor.)

## How to Cope with Test Run Abnormality

### The phenomena from main component failure

Component	Phenomenon	Cause	Check method and Trouble shooting
<b>Compressor</b>	Not operating	Motor insulation broken	Check resistance between terminals and chassis
	Stop during running	Motor insulation failure	Check resistance between terminals and chassis
	Loud noise during running	Phase sequence fault	Check wiring(R, S, T) sequence, or inter change last two phase connection.
<b>Outdoor fan</b>	High pressure error at cooling	Motor failure, bad ventilation around outdoor heat exchanger	Check the outdoor fan operation after being turned the outdoor units off for some time. Remove obstacles around the outdoor units
<b>Outdoor LEV</b>	Heating failure, frequent defrosting	Bad connector contact	Check connector
	No operating sound at applying power	Coil failure	Check resistance between terminals
	Heating failure, frozen outdoor heat exchanger part	LEV clogged	Service necessary
	Low pressure error or discharge temperature error	LEV clogged	Service necessary

When system fault occurs, the error code is displayed at indoor unit display or remote control display, the trouble shooting guide is in the service manual

## Self-Diagnosis Function

### Error Indicator

- This function indicates types of failure in self-diagnosis and occurrence of failure for air condition.
- Error mark is displayed on display window of indoor units and wired remote controller, and 7-segment LED of outdoor unit control board as shown in the table.
- If more than two troubles occur simultaneously, lower number of error code is first displayed.
- After error occurrence, if error is released, error LED is also released simultaneously.

	Display		Title	Cause of Error
Indoor unit related error	0	1	Air temperature sensor of indoor unit	Air temperature sensor of indoor unit is open or short
	0	2	Inlet pipe temperature sensor of indoor unit	Inlet pipe temperature sensor of indoor unit is open or short
	0	3	Transmission error : wired remote controller ↔ indoor unit	Failing to receive wired remote controller signal at indoor unit PCB
	0	4	Drain pump	Malfunction of drain pump
	0	5	Transmission error : outdoor unit ↔ indoor unit	Failing to receive outdoor unit signal at indoor unit PCB
	0	6	Outlet pipe temperature sensor of indoor unit	Outlet pipe temperature sensor of indoor unit is open or short
	0	7	Different operation mode	Operation mode between indoor unit and outdoor unit is different
	0	9	Serial No.	In the case that the serial number marked on EEPROM of Indoor unit is 0 or FFFFFF
	1	0	Poor fan motor operation	Disconnecting the fan motor connector/Failure
	1	1	Transmission error: indoor unit → main PCB of outdoor.	When the signal doesn't come out for 3mins. suddenly, while the indoor unit gets the calling signal coming from the outdoor unit,
Power related error	2	1	DC peak	IPM fault or overcurrent to compressor
	2	2	Overcurrent of inverter comp.	Overcurrent flows to inverter compressor
	2	3	Poor voltage charge for driving INV compressor	DC charging is not performed after starting relay turn on
	2	4	High pressure switch of main outdoor unit	System is off by high pressure switch
	2	5	Low/Over voltage	Input voltage is out of tolerable range.
Compressor related error	3	2	Discharge temperature of main outdoor unit (INV compressor)	System is off due to rising of INV compressor discharge temperature
	3	3	Discharge temperature of main outdoor unit (constant speed compressor)	System is off due to rising of constant speed compressor discharge temperature
	3	4	High pressure of main outdoor unit	System is off by excessive increase of high pressure of main outdoor unit
	3	5	Low pressure of main outdoor unit	System is off by excessive decrease of low pressure of main outdoor unit

	Display	Title	Cause of Error
Outdoor unit related error	4 0	Current sensor of inverter compressor	Current sensor of inverter compressor is open or short
	4 1	Discharge temperature sensor of inverter compressor	Discharge temperature sensor of inverter compressor is open or short
	4 2	Low pressure sensor of main outdoor unit	Low pressure sensor of main outdoor unit is open or short
	4 3	High pressure sensor of main outdoor unit	High pressure sensor of main outdoor unit is open or short
	4 4	Air temperature sensor of main outdoor unit	Air temperature sensor of main outdoor unit is open or short
	4 5	Temperature sensor of front-side heat exchanger	Temperature sensor of front-side heat exchanger is open or short
	4 6	Suction temperature sensor of main outdoor unit	Suction temperature sensor of main outdoor unit is open or short
	4 7	Discharge temperature sensor of the constant speed compressor of main outdoor unit	Discharge temperature sensor of the constant speed compressor of main outdoor unit is open or short
	4 8	Temperature sensor of rear-side heat exchanger	Temperature sensor of rear-side heat exchanger is open or short
Transmission related error	5 1	Excessive capacity of indoor units	Excessive connection of indoor units compared to capacity of outdoor unit
	5 2	Transmission error : inverter PCB → main PCB	Failing to receive inverter signal at main PCB
	5 3	Transmission error : indoor unit → main PCB of outdoor unit	Failing to receive indoor unit signal at main PCB of outdoor unit
	5 4	Reverse connection of R, S, T power of main outdoor unit	Reverse connection or omitting connection of R, S, T power of main outdoor unit
	5 7	Transmission error : main PCB → inverter PCB	Failing to receive main PCB signal at inverter PCB
Outdoor unit related error	6 2	Overheat of inverter heatsink	Overheat of inverter heatsink
	6 5	Temperature sensor of fan	Temperature sensor of fan is open or short

Test Run

	Display		Title	Cause of Error
<b>Compressor related error</b>	1	0 0	Discharge temperature of constant speed compressor 1 of sub1 outdoor unit	System is off by excessive increase of discharge temperature of constant speed compressor 1 of sub1 outdoor unit
	1	0 1	Discharge temperature of constant speed compressor 2 of sub1 outdoor unit	System is off by excessive increase of discharge temperature of constant speed compressor 2 of sub1 outdoor unit
	1	0 2	Discharge temperature of constant speed compressor 1 of sub2 outdoor unit	System is off by excessive increase of discharge temperature of constant speed compressor 1 of sub2 outdoor unit
	1	0 3	Discharge temperature of constant speed compressor 2 of sub2 outdoor unit	System is off by excessive increase of discharge temperature of constant speed compressor 2 of sub2 outdoor unit
<b>Transmission related error</b>	1	0 4	Transmission error : sub1 outdoor unit → main outdoor unit	Failing to receive sub1 signal at main PCB of main outdoor unit
	1	0 5	Transmission error : fan PCB → main PCB	Failing to receive fan signal at main PCB
	1	0 6	Over-current of fan motor (IPM fault)	Over-current of fan motor (IPM fault)
	1	0 7	Low voltage of fan motor driver	Low voltage of fan motor driver
	1	0 8	Transmission error : main PCB → fan PCB	Failing to receive main signal at fan PCB
	1	0 9	High pressure switch of sub1 outdoor unit	High pressure switch of sub1 outdoor unit is operated by high pressure rising
	1	1 0	Reverse connection of R, S, T power of sub1 outdoor unit	Reverse connection or omitting connection of R, S, T power of sub1 outdoor unit
<b>Outdoor unit related error</b>	1	1 3	Liquid pipe temperature sensor of main outdoor unit	Liquid pipe temperature sensor of main outdoor unit is open or short
	1	1 4	Subcooling inlet temperature sensor of main outdoor unit	Subcooling inlet temperature sensor of main outdoor unit is open or short
	1	1 5	Subcooling outlet temperature sensor of main outdoor unit	Subcooling outlet temperature sensor of main outdoor unit is open or short
	1	1 6	High pressure sensor of sub1 outdoor unit	High pressure sensor of sub1 outdoor unit is open or short
	1	1 7	Low pressure sensor of sub1 outdoor unit	Low pressure sensor of sub1 outdoor unit is open or short
	1	1 8	Air temperature sensor of sub1 outdoor unit	Air temperature sensor of sub1 outdoor unit is open or short
	1	2 0	Suction temperature sensor of sub1 outdoor unit	Suction temperature sensor of sub1 outdoor unit is open or short
	1	2 1	Discharge temperature sensor of the constant speed compressor 1 of sub1 outdoor unit	Discharge temperature sensor of the constant speed compressor 1 of sub1 outdoor unit is open or short
	1	2 2	Discharge temperature sensor of the constant speed compressor 2 of sub1 outdoor unit	Discharge temperature sensor of the constant speed compressor 2 of sub1 outdoor unit is open or short
	1	2 3	Temperature sensor of front-side heat exchanger of sub1 outdoor unit	Temperature sensor of front-side heat exchanger of sub1 unit is open or short

			Display	Title	Cause of Error
Outdoor unit related error	1	2	4	Temperature sensor of rear-side heat exchanger of sub1 outdoor unit	Temperature sensor of rear-side heat exchanger of sub1 unit is open or short
	1	2	5	Liquid pipe temperature sensor of sub1 outdoor unit	Liquid pipe temperature sensor of sub1 outdoor unit is open or short
	1	2	6	Subcooling inlet temperature sensor of sub1 outdoor unit	Subcooling inlet temperature sensor of sub1 outdoor unit is open or short
	1	2	7	Subcooling outlet temperature sensor of sub1 outdoor unit	Subcooling outlet temperature sensor of sub1 outdoor unit is open or short
	1	2	8	High pressure sensor of sub2 outdoor unit	High pressure sensor of sub2 outdoor unit is open or short
	1	2	9	Low pressure sensor of sub2 outdoor unit	Low pressure sensor of sub2 outdoor unit is open or short
	1	3	0	Air temperature sensor of sub2 outdoor unit	Air temperature sensor of sub2 outdoor unit is open or short
	1	3	2	Suction temperature sensor of sub2 outdoor unit	Suction temperature sensor of sub2 outdoor unit is open or short
	1	3	3	Discharge temperature sensor of the constant speed compressor 1 of sub2 outdoor unit	Discharge temperature sensor of the constant speed compressor 1 of sub2 outdoor unit is open or short
	1	3	4	Discharge temperature sensor of the constant speed compressor 2 of sub2 outdoor unit	Discharge temperature sensor of the constant speed compressor 2 of sub2 outdoor unit is open or short
	1	3	5	Temperature sensor of front-side heat exchanger of sub2 outdoor unit	Temperature sensor of front-side heat exchanger of sub2 unit is open or short
	1	3	6	Temperature sensor of rear-side heat exchanger of sub2 outdoor unit	Temperature sensor of rear-side heat exchanger of sub2 unit is open or short
	1	3	7	Liquid pipe temperature sensor of sub2 outdoor unit	Liquid pipe temperature sensor of sub2 outdoor unit is open or short
	1	3	8	Subcooling inlet temperature sensor of sub2 outdoor unit	Subcooling inlet temperature sensor of sub2 outdoor unit is open or short
	1	3	9	Subcooling outlet temperature sensor of sub2 outdoor unit	Subcooling outlet temperature sensor of sub2 outdoor unit is open or short
	1	4	0	High pressure sensor of sub2 outdoor unit	High pressure sensor of sub2 outdoor unit is open or short
	1	4	1	Reverse connection of R, S, T power of sub2 outdoor unit	Reverse connection or omitting connection of R, S, T power of sub2 outdoor unit
	1	4	2	Transmission error : main outdoor unit → sub1 outdoor unit	Failing to receive main signal at main PCB of sub2 outdoor unit
	1	4	3	High pressure of sub1 outdoor unit	System is off by excessive increase of high pressure of sub1 outdoor unit
	1	4	4	Low pressure of sub1 outdoor unit	System is off by excessive decrease of low pressure of sub1 outdoor unit
1	4	5	High pressure of sub2 outdoor unit	System is off by excessive increase of high pressure of sub2 outdoor unit	
1	4	6	Low pressure of sub2 outdoor unit	System is off by excessive decrease of low pressure of sub2 outdoor unit	
1	4	7	Low/high voltage of sub1 outdoor unit	Input voltage of sub1 outdoor unit is more than 487V or less than 270V	

Test Run

	Display			Title	Cause of Error
Outdoor unit related error	1	4	8	Voltage detection circuit of sub1 outdoor unit	Voltage detection circuit of sub1 outdoor unit is out of order
	1	4	9	Low/high voltage of sub2 outdoor unit	Input voltage of sub2 outdoor unit is more than 487V or less than 270V
	1	5	0	Voltage detection circuit of sub2 outdoor unit	Voltage detection circuit of sub2 outdoor unit is out of order
	1	5	1	Failure of operation mode conversion	Pressure unbalance between outdoor units
	1	7	3	Failure of Main constant speed compressor operation	Comp locking, Check Valve leakage, comp dielectric breakdown
	1	7	4	Failure of Sub1 constant speed compressor1 operation	Comp locking, Check Valve leakage, comp dielectric breakdown
	1	7	5	Failure of Sub1 constant speed compressor2 operation	Comp locking, Check Valve leakage, comp dielectric breakdown
	1	7	6	Failure of Sub2 constant speed compressor1 operation	Comp locking, Check Valve leakage, comp dielectric breakdown
	1	7	7	Failure of Sub2 constant speed compressor2 operation	Comp locking, Check Valve leakage, comp dielectric breakdown
	1	7	8	Failure of Sub3 constant speed compressor1 operation	Comp locking, Check Valve leakage, comp dielectric breakdown
	1	7	9	Failure of Sub3 constant speed compressor2 operation	Comp locking, Check Valve leakage, comp dielectric breakdown

■ Please refer to trouble shooting guide in service manual for each error title



**CAUTION**

In case that the control box is opened and before checking electrical parts, it should be checked that the LED 01Y (Refer to next page) turned off (wait 3 minutes after main power OFF), otherwise, it may cause electrical shock.

Position of the LED01Y in inverter board

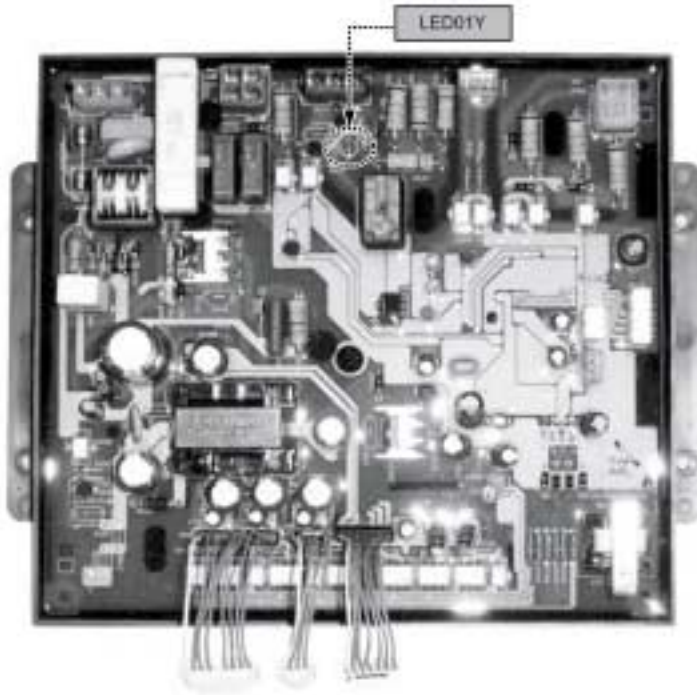

# Caution For Refrigerant Leak

The installer and system specialist shall secure safety against leakage according to local regulations or standards. The following standards may be applicable if local regulations are not available.

## Introduction

Though the R410A refrigerant is harmless and incombustible itself, the room to equip the air conditioner should be large to such an extent that the refrigerant gas will not exceed the limiting concentration even if the refrigerant gas leaks in the room.

## Limiting concentration

Limiting concentration is the limit of Freon gas concentration where immediate measures can be taken without hurting human body when refrigerant leaks in the air. The limiting concentration shall be described in the unit of  $\text{kg/m}^3$  (Freon gas weight per unit air volume) for facilitating calculation.

**Limiting concentration:  $0.3\text{kg/m}^3$ (R410A)**

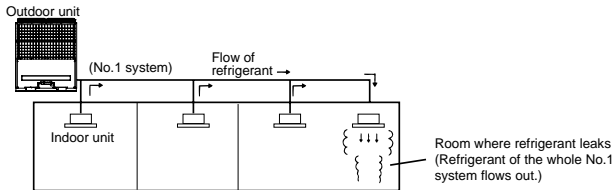

## Checking procedure of limiting concentration

Check limiting concentration along following steps and take appropriate measure depending on the situation.

## Calculate amount of all the replenished refrigerant (kg) per each refrigerant system.

$$\begin{array}{rcccl}
 \text{Amount of replenished} & & \text{Amount of additional} & = & \text{Total amount of replenished} \\
 \text{refrigerant per one outdoor} & + & \text{replenished refrigerant} & & \text{refrigerant in refrigerant} \\
 \text{unit system} & & & & \text{facility (kg)} \\
 \downarrow & & \downarrow & & \\
 \text{Amount of replenished} & & \text{Amount of additionally} & & \text{Note : In case one refrigerant facility is} \\
 \text{refrigerant at factory shipment} & & \text{replenished refrigerant} & & \text{divided into 2 or more refrigerant} \\
 & & \text{depending on piping} & & \text{systems and each system is} \\
 & & \text{length or piping} & & \text{independent, amount of replenished} \\
 & & \text{diameter at customer} & & \text{refrigerant of each system shall be} \\
 & & & & \text{adopted.}
 \end{array}$$

## Calculate minimum room capacity

Calculate room capacity by regarding a portion as one room or the smaller room.

(1) Without partition

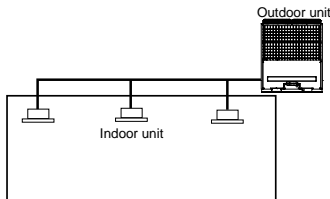

(2) With partition and with opening which serve as passage of air to adjoining room

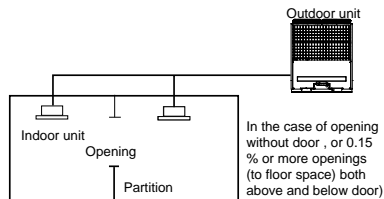

(3) With partition and without opening which serve as passage of air to adjoining room

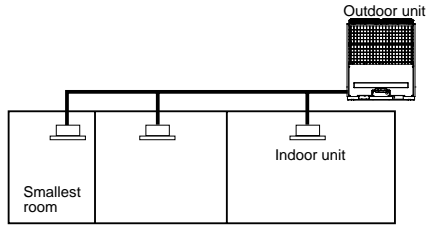

### ■ Calculate refrigerant concentration

$$\frac{\text{Total amount of replenished refrigerant in refrigerant facility (kg)}}{\text{Capacity of smallest room where indoor unit is installed (m}^3\text{)}} = \text{Refrigerant concentration (kg/m}^3\text{)} \quad \text{(R410A)}$$

In case the result of calculation exceeds the limiting concentration, perform the same calculations by shifting to the second smallest, and the third smallest rooms until at last the result is below the limiting concentration.

### ■ In case the concentration exceeds the limit

When the concentration exceeds the limit, change original plan or take one of the countermeasures shown below:

- **Countermeasure 1**

Provide opening for ventilation.

Provide 0.15% or more opening to floor space both above and below door, or provide opening without door.

- **Countermeasure 2**

Provide gas leak alarm linked with mechanical ventilator.

Reducing the outdoor refrigerant qty.

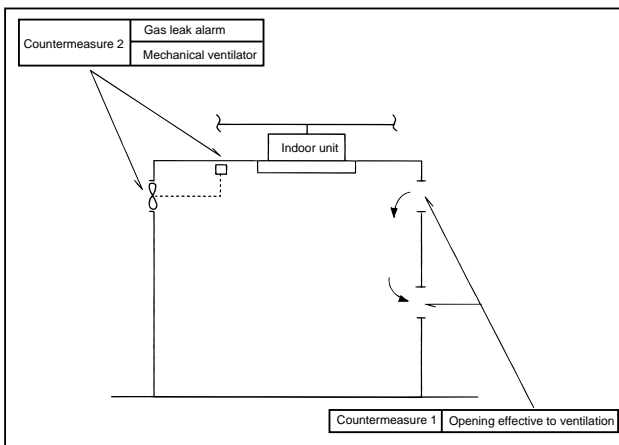

Pay a special attention to the place, such as a basement, etc. where refrigerant can stay, since refrigerant is heavier than air.

