



website <http://www.lgservice.com>

LG

ENGLISH

РУССКИЙ

LG

Air Conditioner

INSTALLATION MANUAL

Type : Convertible

IMPORTANT

- Please read this instruction manual completely before installing the product.
- Installation work must be performed in accordance with the national wiring standards by authorized personnel only.
- Please retain this installation manual for future reference after reading it thoroughly.

TABLE OF CONTENTS

Installation Requirements

Safety Precautions3

Installation of Indoor, Outdoor unit.....5

Connecting Pipes to the Indoor Unit 14

Connecting Pipes to the Outdoor Unit22

Checking the Drainage22

Connecting Cables between Indoor Unit and Outdoor Unit24

Air Purging of the Connecting Pipes and the Indoor Unit27

Test running.....29

Installation guide at the seaside.....30

Required Parts

- Installation Plate
- Four Type “A” screws
- Connecting cable

- Pipes: Gas side
Liquid side
- Insulated drain hose
- Insulation materials

- Additional Drain hose (Inner Dia.....25mm)

- Two type “B” screws

Required Tools

- Level
- Screw driver
- Electric drill
- Hole core drill (ø70mm)

- Flaring Tools set
- Specified Torque Wrenches

- Specified Torque Wrenches

- Screw driver

- Hexagonal Wrench (4mm/5mm)
- Gas-leak Detector

- Owner’s Manual
- Thermometer

Safety Precautions



To prevent injury to the user or other people and property damage, the following instructions must be followed.

- Incorrect operation due to ignoring instruction will cause harm or damage. The seriousness is classified by the following indications.

⚠ WARNING This symbol indicates the possibility of death or serious injury.

⚠ CAUTION This symbol indicates the possibility of injury or damage.

- Meanings of symbols used in this manual are as shown below.

	Be sure not to do.
	Be sure to follow the instruction.

⚠ WARNING

■ Installation

Do not use a defective or underrated circuit breaker. Use this appliance on a dedicated circuit.

- There is risk of fire or electric shock.

For electrical work, contact the dealer, seller, a qualified electrician, or an Authorized Service Center.

- Do not disassemble or repair the product. There is risk of fire or electric shock.

Always ground the product.

- There is risk of fire or electric shock.

Install the panel and the cover of control box securely.

- There is risk of fire or electric shock.

Always install a dedicated circuit and breaker.

- Improper wiring or installation may cause fire or electric shock

Use the correctly rated breaker or fuse.

- There is risk of fire or electric shock.

Do not modify or extend the power cable.

- There is risk of fire or electric shock.

Be cautious when unpacking and installing the product.

- Sharp edges could cause injury. Be especially careful of the case edges and the fins on the condenser and evaporator.

For installation, always contact the dealer or an Authorized Service Center.

- There is risk of fire, electric shock, explosion, or injury.

Do not install the product on a defective installation stand.

- It may cause injury, accident, or damage to the product.

Be sure the installation area does not deteriorate with age.

- If the base collapses, the air conditioner could fall with it, causing property damage, product failure, and personal injury.

Do not let the air conditioner run for a long time when the humidity is very high and a door or a window is left open.

- Moisture may condense and wet or damage furniture.

■ Operation

Do not store or use flammable gas or combustibles near the product.

- There is risk of fire or failure of product.

 **CAUTION**

■ Installation

Always check for gas (refrigerant) leakage after installation or repair of product.

- Low refrigerant levels may cause failure of product.

Install the drain hose to ensure that water is drained away properly.

- A bad connection may cause water leakage.

Keep level even when installing the product.

- To avoid vibration or water leakage.

Do not install the product where the noise or hot air from the outdoor unit could damage the neighborhoods.

- It may cause a problem for your neighbors.

Use two or more people to lift and transport the product.

- Avoid personal injury.

Do not install the product where it will be exposed to sea wind (salt spray) directly.

- It may cause corrosion on the product. Corrosion, particularly on the condenser and evaporator fins, could cause product malfunction or inefficient operation.

Installation of Indoor, Outdoor Unit

1. Selection of the best location

1) Indoor unit

- There should not be any heat source or steam near the unit.
- There should not be any obstacles to prevent the air circulation.
- A place where air circulation in the room will be good.
- A place where drainage can be easily obtained.
- A place where noise prevention is taken into consideration.
- Do not install the unit near the door way.
- Ensure the spaces indicated by arrows from the wall, ceiling, or other obstacles.

VB CHASSIS

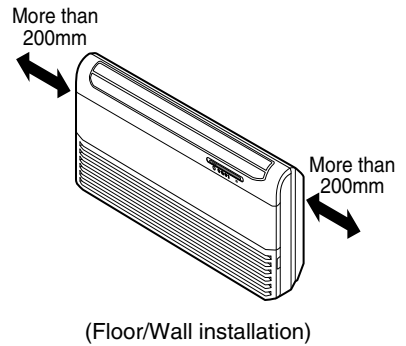
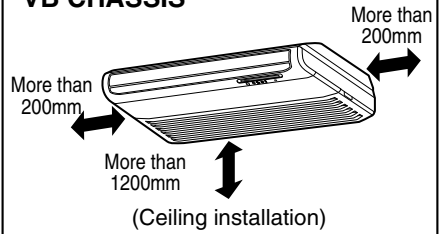

VK,VJ,VL CHASSIS

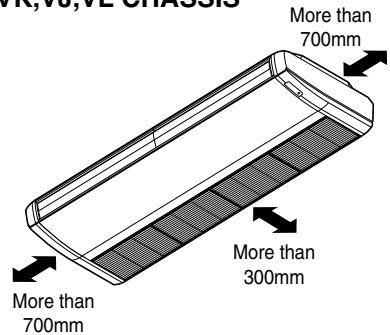

2) Outdoor unit

- If an awning is built over the unit to prevent direct sunlight or rain exposure, make sure that heat flow from the condenser is not restricted.
- Ensure that the space around the back and sides is more than 300mm. The front of the unit should have more than 700mm of space.
- Do not place animals and plants in the path of the warm air.
- Take the weight of the air conditioner into account and select a place where noise and vibration are minimum.
- Select a place where the warm air and noise from the air conditioner do not disturb neighbors.

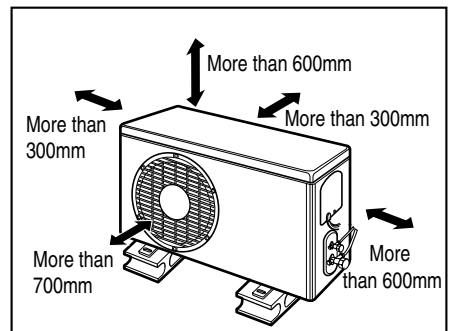

3) Piping length and the elevation

Model	Pipe Size (Diameter:Ø)		Length A(m)		Elevation B(m)		*Additional refrigerant(g/ m)
	Gas	Liquid	Standard	Max.	Standard	Max.	
LV-C186BLA0	5/8"(15.88mm)	1/4"(6.35mm)	7.5	30	5	20	30
LV-H186BLA0	5/8"(15.88mm)	1/4"(6.35mm)	7.5	30	5	20	30
LV-C246BLA1	5/8"(15.88mm)	1/4"(6.35mm)	7.5	30	5	20	30
LV-C286BLA1	5/8"(15.88mm)	1/4"(6.35mm)	7.5	30	5	20	25
LV-H246BLA1	5/8"(15.88mm)	1/4"(6.35mm)	7.5	30	5	20	30
LV-C362KLA0	5/8"(15.88mm)	1/4"(6.35mm)	5	20	5	30	25
LV-C602LLA0	3/4"(19.05mm)	3/8"(9.52mm)	7.5	20	5	30	60
LV-C60BLLA0	3/4"(19.05mm)	3/8"(9.52mm)	7.5	20	5	30	50
LV-C602LLA2	3/4"(19.05mm)	3/8"(9.52mm)	7.5	20	5	30	50

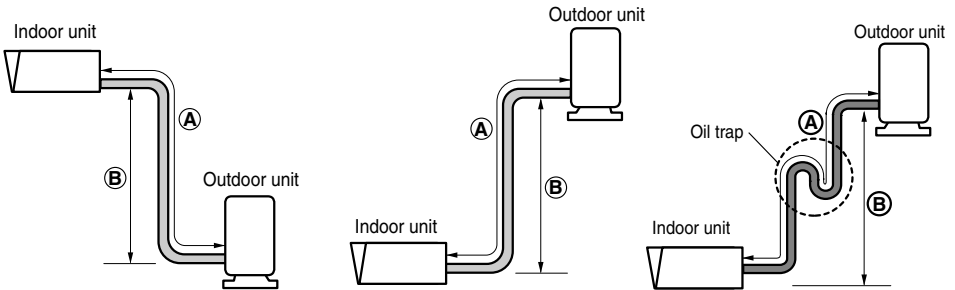

⚠ CAUTION

- Rated performance for refrigerant line length of:7.5m
- Capacity is based on standard length and maximum allowance length is on the basis of reliability.
- Improper refrigerant charge may result in abnormal cycle.
- Oil trap should be installed every 10 meters.

■ VB CHASSIS

1. Indoor unit installation

■ Before Installing, prepare Installation Plates

- 'Installation Plates' are attached at the bottom of indoor unit.
Detach them by removing each 3 screws at both sides.
- Pull the upper right and left side of 'Inlet Grille' to the front, and it will stop at slightly tilted position.
- Unhook the 'Inlet hanger' from the 'Hanger screw' on the both left and right side.
- Detach the 'Inlet Grille' from the Indoor Unit.
- Detach 'Side Plate (R,L)' by removing each 3 screws on both sides.

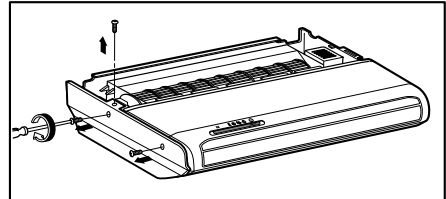
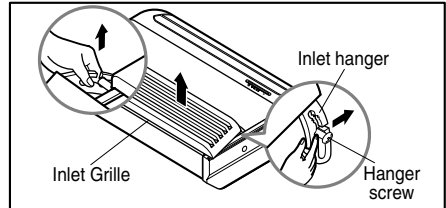
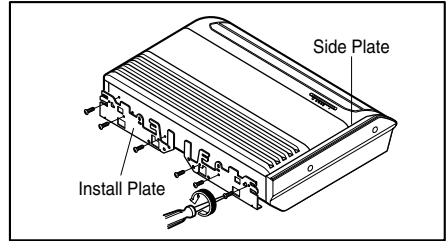

1) Installation on the ceiling

- Measure and mark the position for the Suspension bolts and the piping hole.
- Drill the hole for anchor nut on the ceiling.

※ Before secure the Installation Plates, select the bent direction of the Installation Plate to the inside or the outside according to the installation circumstances.

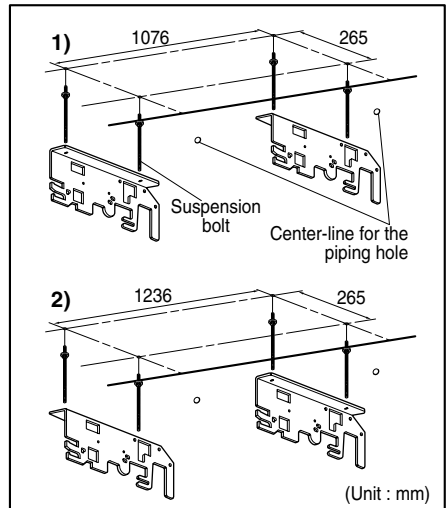

- Drill the piping hole on the wall slightly tilted to the outdoor side using a $\varnothing 70$ hole-core drill.

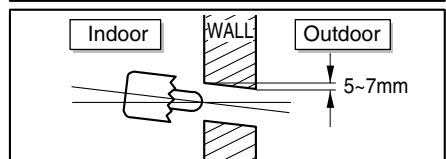

- Insert the nuts and washer onto the suspension bolts for locking the suspension bolts on the ceiling.
- Mount the suspension bolts to the anchor-nuts firmly.
- Secure the Installation plates onto the Suspension bolts (adjust level roughly.) using nuts, washers and spring washers.

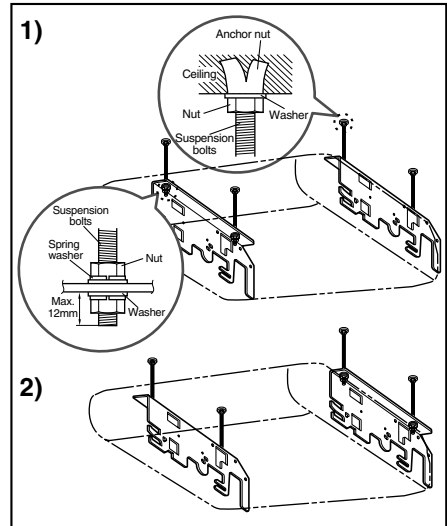

- Engage 2 hooks on the both left and right side of the unit to the lower slot of Installation Plates.
- Adjust a level with a level gauge on the direction of left-right, back-forth by adjusting suspension bolts.
- Move the hooks on the unit to the upper slot of Installation Plates. Then the unit will be declined to the bottomsides so as to drain well.

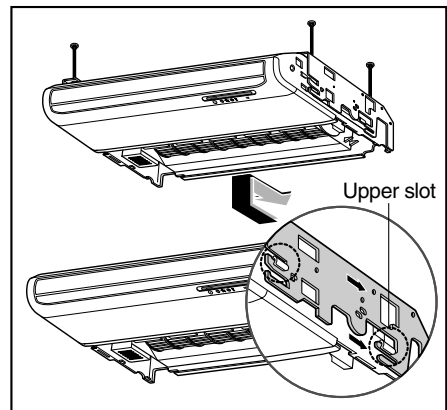
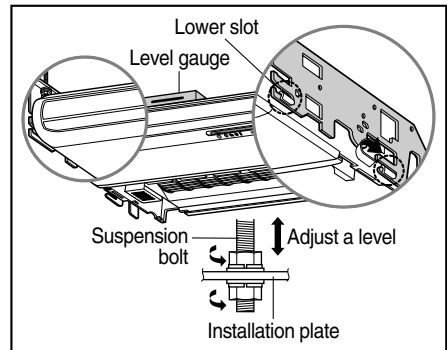

 **CAUTION**

1. **Install declination** of the indoor unit is very **important for the drain** of the convertible type air conditioner.
2. Minimum thickness of the insulation for the connecting pipe shall be 7mm.
3. If the Installation Plates are fixed to horizontal line, the indoor unit after installing will be declined to the bottomside.

Front of view

- The unit must be horizontal or declined to the drain hose connected when finished installation.

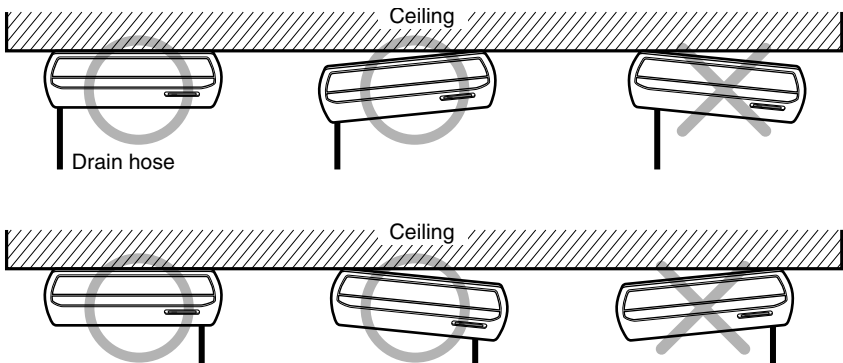
**Side of view**

- The unit must be declined to the bottomside of the unit when finished installation.

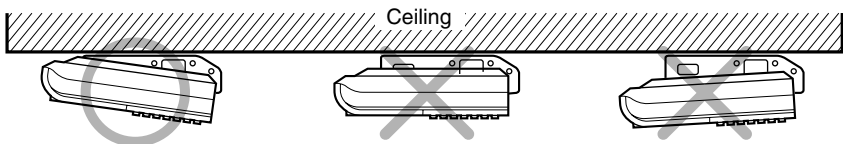

- Secure the unit to the Installation Plates with four M8 bolts and washers.

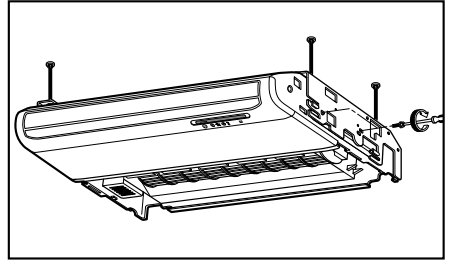

- Fit the projection hooks of the side plates to the 'Side Panel' and the 'Front Panel' by lifting it.

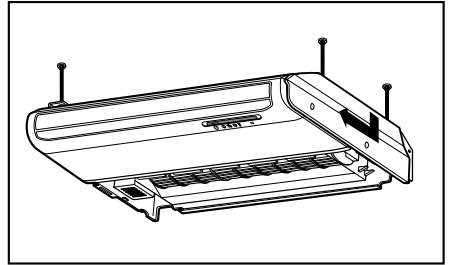

- Fasten the screws.

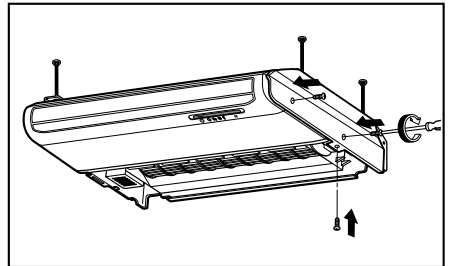

- Hook up the Inlet Grille Hook to the cabinet.
- Hang the Inlet Hanger to the screw.

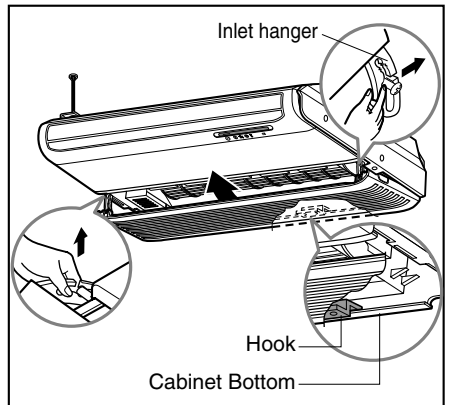

2. Installation on the Wall

- Select and mark the position for fixing bolts and piping hole.
Decide the position for fixing bolts slightly tilted to the drain direction after considering the direction of drain hose.
- Drill the hole for anchor nut on the wall.

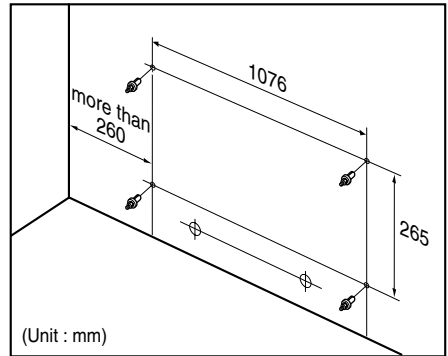

- Drill the piping hole on the wall slightly tilted to the outdoor side using a $\phi 70$ hole-core drill.

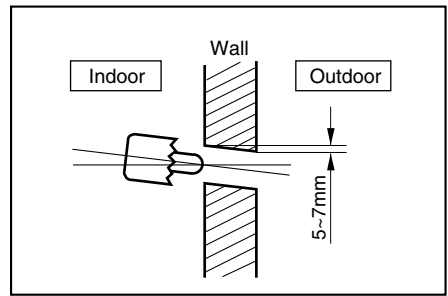

- Secure the 'Install Plate' onto the wall with four anchor bolts, washers and spring washers.

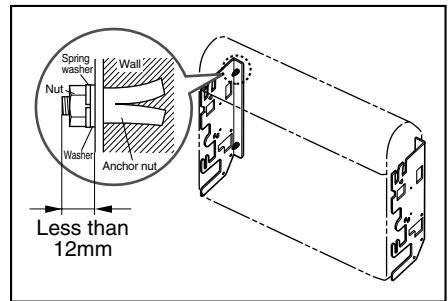

- ※ Before secure the Install Plates, select the bent direction of the 'Install Plate' to the inside or outside according to the installation circumstances.

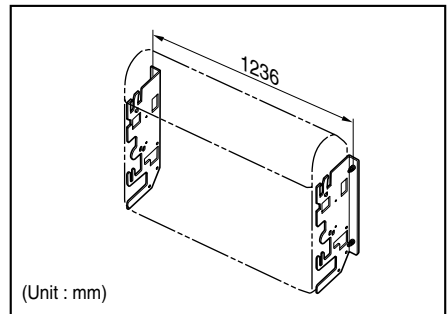

Install the Indoor unit onto Installation Plate.

- Insert 2 hooks on the both left and right side of the unit to the inner slot (wall side) of the Installation Plate.
- Secure the unit to the Installation Plate with four M8 bolts and washers.

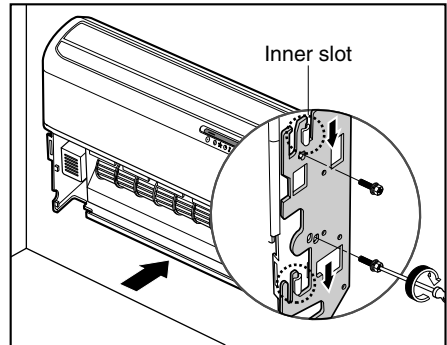

- Before working, refer to "Connecting the pipes to the Indoor Unit" on page 16.

- Fit the projection hooks of the side plates to the 'Side Panel' and the 'Front Panel' by lifting it.
- Fasten the screws.

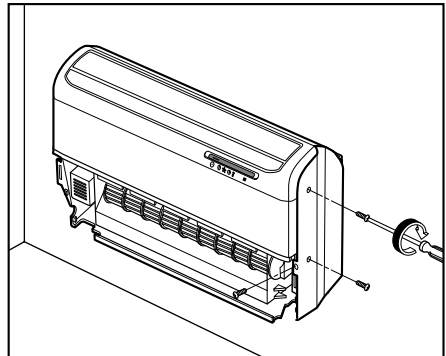

- Hook up the Inlet Grille Hook to the cabinet.
- Hang the Inlet Hanger to the screw.

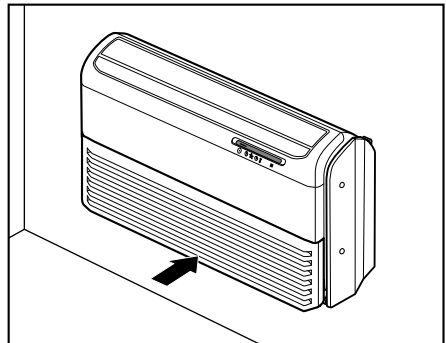

3. Installation on the floor

Installation of Mount Bracket.

- Select and mark the position for Mount Brackets and the piping hole.
- Drill the hole for the anchor nut on the wall.
- Drill the piping hole using a $\phi 70$ hole-core drill.
- Secure the Mount Brackets on the wall with four M4 screws.

Install the indoor unit onto the Mount Brackets.

- Engage the slot at the back of the unit with Mount Bracket.

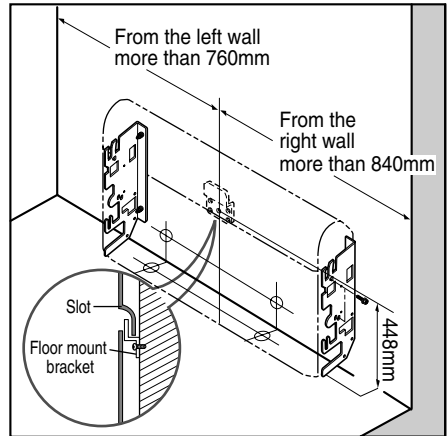

- Drill the piping hole with 70mm dia, hole core drill.
- Piping hole should be slightly slant to the outdoor side.

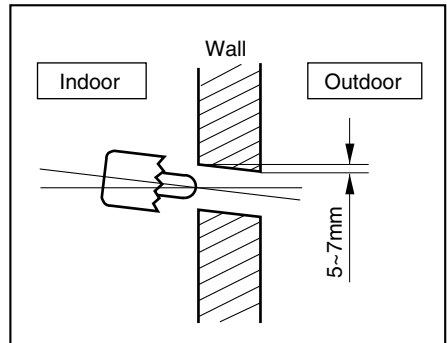

After Installing, reassemble detached parts.

- Hang the 'Inlet Grille' and hook the 'Inlet Hanger' to the Hanger Screw.
- Assemble the 'Side Plates(R,L)' with 2 screws on both left and right side.

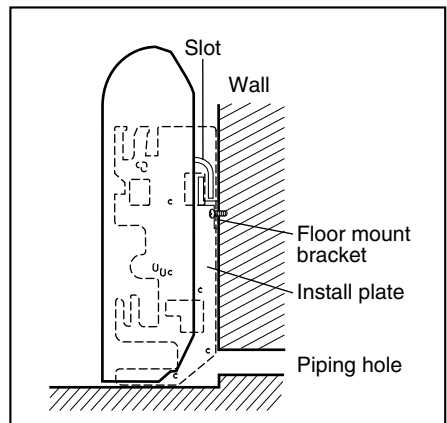

■ VK,VL,VJ CHASSIS

1.Preparing Work for Installation

Open side cover

1. Remove two screws from side-cover as shown in fig.
2. Unlock side-cover from side panel by slightly pulling the edge of side cover.
3. Tap the side-cover with your palm on the backside.(Inlet grill side.)
4. Hold the side-cover with other hand while tapping to prevent it to fall down.
5. The Drain hole is on the left side of the unit and side cover opening is common for drain pipe,connecting pipe and wiring diagram.
6. Remove the rubber stopple in the desired drain direction.
7. Knock out the pipe hole from the left side-cover with the help of nipper/plier.
8. Knock hole on right side-cover only if right side is selected for water drain.

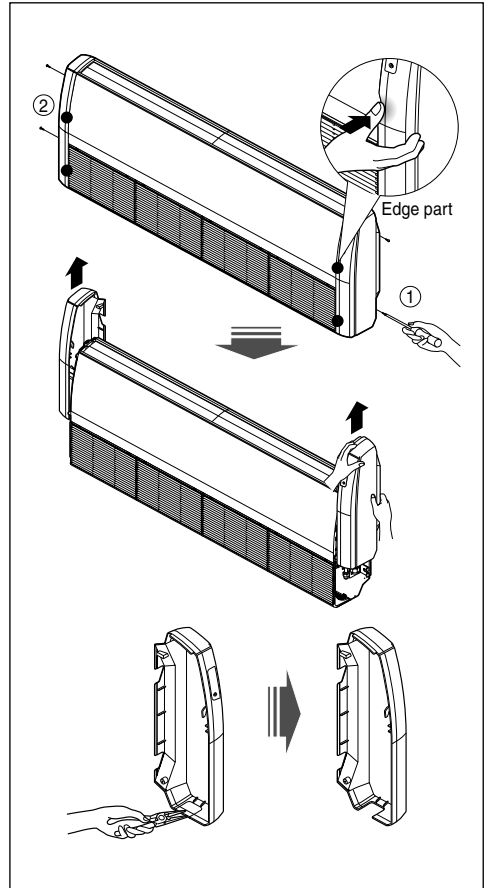

MOUNTING THE ANCHOR NUT AND BOLT

- Prepare 4 suspension bolts. (Each bolts length should be same.)
- Measure and mark the position for the Suspension bolts and the piping hole.
- Drill the hole for anchor nut on the ceiling.
- Insert the nuts and washer onto the suspension bolts for locking the suspension bolts on the ceiling.
- Mount the suspension bolts to the anchor-nuts firmly.
- Secure the hangers onto the Suspension bolts (adjust level roughly.) using nuts, washers and spring washers.
- Adjust a level with a level gauge on the direction of left-right, back-forth by adjusting suspension bolts.
- Adjust a level on the direction of top-bottom by adjusting suspension bolts. Then the unit will be declined to the bottomsides so as to drain well.

DIM.	A(mm)	B(mm)
VL	1655	320
VK	1255	320
VJ	855	320

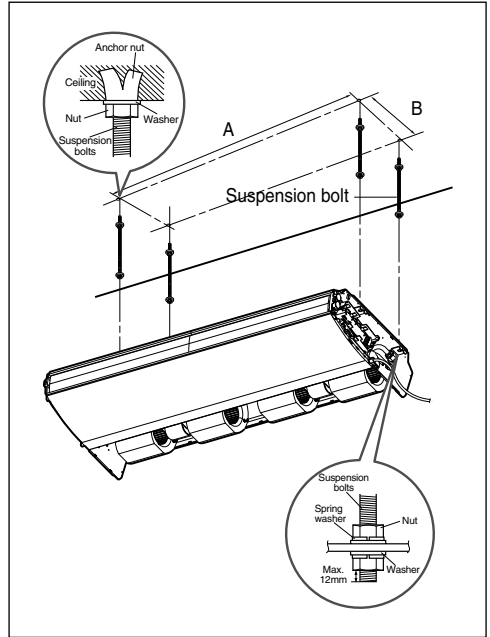

⚠ CAUTION

: Tighten the nut and bolt to prevent unit falling.

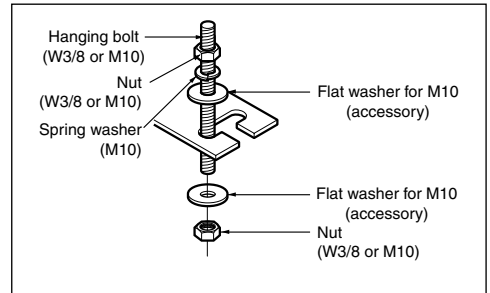

DRILL A HOLE IN THE WALL.

- Drill the piping hole with a $\phi 70$ mm hole core drill. Drill the piping hole at either the right or the left with the hole slightly slanted to the outdoor side.

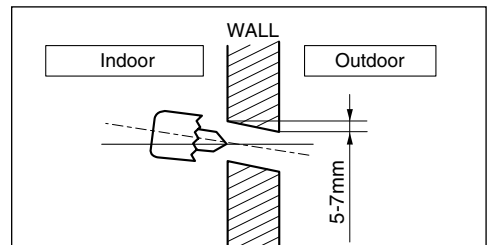

2. Indoor unit installation

Hang the Indoor unit on suspension bolt as per following guidelines:

1. Lift the indoor unit to sufficient height.
2. Insert the suspended part of four suspension bolt in the four hangers provided on the side of main body one by one.
3. Lower the indoor unit till the hangers rest on their respective flat washer.
4. Adjust the level in the top down direction by adjusting the suspension bolts.
Inclined the indoor unit as per direction provided in the fig

⚠ CAUTION

: Installation Information For Declination

1. **Install declination** of the indoor unit is very **important for the drain** of the convertible type air conditioner.
2. Minimum thickness of the insulation for the connecting pipe shall be 10mm.
3. If the Installation Plates are fixed to horizontal line, the indoor unit after installing will be declined to the bottomside.

Front of view

- The unit must be horizontal or inclined at angle.
- The inclination should be less than or equal to 1° or in between 10 to 20mm inclined in drain direction as shown in fig.

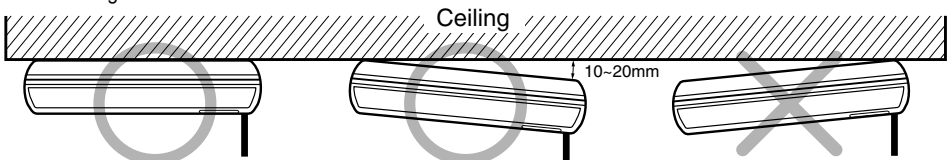

Side of view

- The unit must be declined to the bottomside of the unit when finished installation.

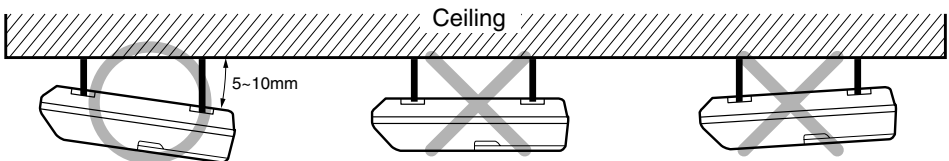

Connecting Pipes to the Indoor Unit

1. Preparation of Piping

Main cause of gas leakage is defect in flaring work. Carry out correct flaring work in the following procedure.

1) Cut the pipes and the cable.

- Use the accessory piping kit or the pipes purchased locally.
- Measure the distance between the indoor and the outdoor unit.
- Cut the pipes a little longer than measured distance.
- Cut the cable 1.5m longer than the pipe length.

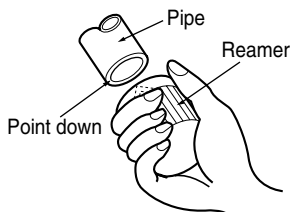
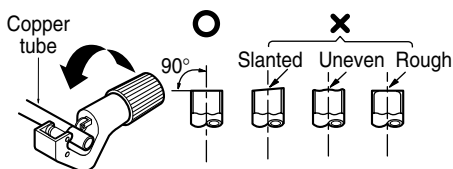

2) Burrs removal

- Completely remove all burrs from the cut cross section of pipe/tube.
- Put the end of the copper tube/pipe to downward direction as you remove burrs in order to avoid to let burrs drop in the tubing.

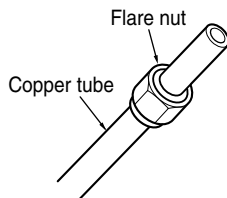

3) Putting nut on

- Remove flare nuts attached to indoor and outdoor units, than put them on pipe/tube having completed burr removal.
(Not possible to put them on after flaring work)

4) Flaring work

- Carry out flaring work using dedicated flaring tool for R-410A as shown right.

Outside diameter		A
mm	inch	mm
Ø6.35	1/4	1.1~1.3
Ø9.52	3/8	1.5~1.7
Ø12.7	1/2	1.6~1.8
Ø15.88	5/8	1.6~1.8
Ø19.05	3/4	1.9~2.1

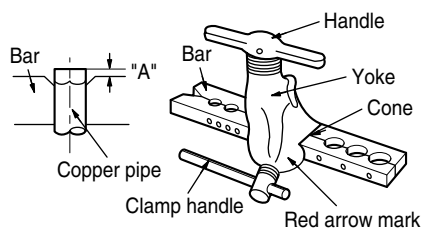

Firmly hold copper pipe in a die in the dimension shown in the table above.

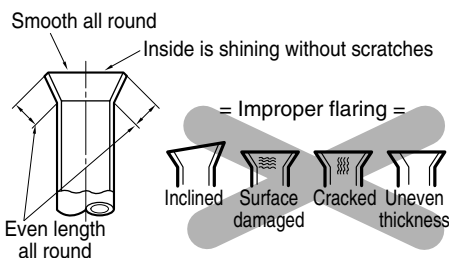

5) Check

- Compare the flared work with figure below.
- If flare is noted to be defective, cut off the flared section and do flaring work again.

2. Connecting of Piping - Indoor

1. Prepare the indoor unit piping and drain hose for installation through the wall.
2. Align the center of the liquid side pipe.
3. Sufficiently tight the flare nut of the liquid side pipe with hands.
4. Tight the flare nut with two spanner, as shown.
5. Align the center of gas side pipes.
6. Sufficiently tight the flare nut of the gas side pipe with hands.
7. Tight the flare nut with two spanner as shown.

Outside diameter		Torque
mm	inch	kgf-cm
Ø6.35	1/4	180~250
Ø9.52	3/8	340~420
Ø12.7	1/2	550~660
Ø15.88	5/8	630~820
Ø19.05	3/4	990~1,210

8. If drain pipe need to be extended at the indoor side attach the drain pipe with indoor unit drain hose as shown in fig.

Wrap the insulation material around connection portion

9. Overlap the connection connecting pipe insulation material and the indoor pipe insulation material. Bind them together with the vinyl tape. So that here may not be any gap.

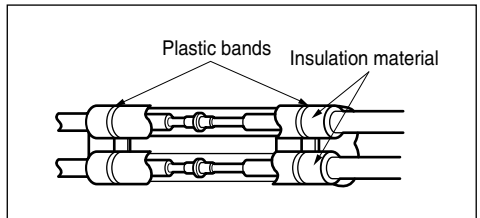
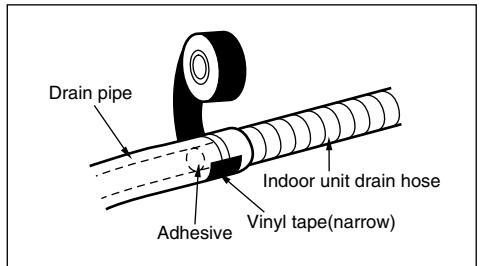
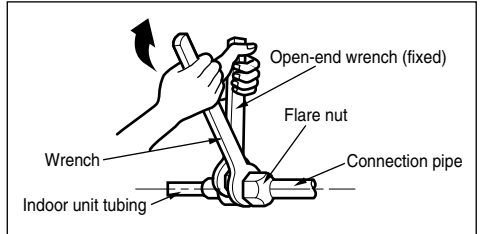
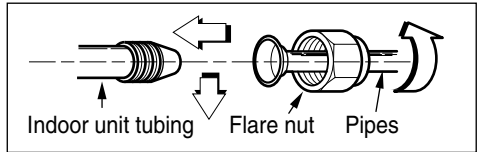

10. If the piping and the drain hose are in common direction bundle the piping and the drain hose together by wrapping them with vinyl tape.

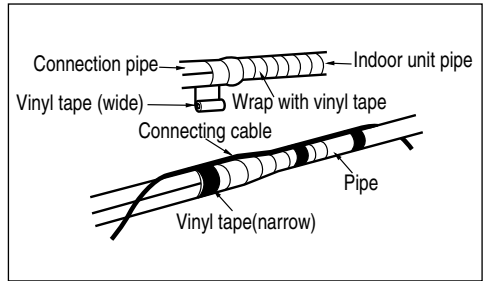

11. Rout the indoor tubing and the drain hose to the required piping hole.

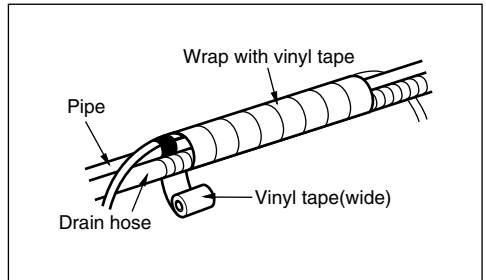

12. Insulation Thickness

Classification	Area with cooling		Area with cooling	
	Normal	Particular	Normal	Particular
Liquid	Ø6.35	More than 9t	More than 9t	
	Ø9.52			
	Ø12.7	More than 13t	More than 13t	
Gas	Ø9.52	More than 13t	More than 19t	More than 19t
	Ø12.7			
	Ø15.88	13t	19t	19t
	Ø19.05			25t

NOTICE

Common direction of drain and piping. Tape the tubing, drain hose and the connecting cable. Be sure that the drain hose is located at the lowest side of the bundle. Locating at the upper side can cause drain pan to overflow inside the unit.

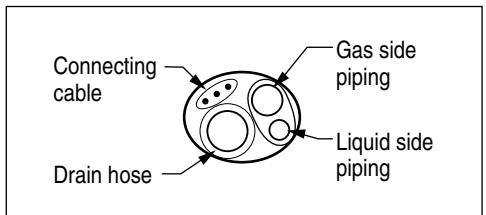

NOTICE

If the drain hose is routed inside the room, insulate the hose with an insulation material* so that dripping from "sweating"(condensation) will not damage furniture or floors.

*Foamed polyethylene or equivalent is recommended.

3. Installation on the ceiling

1) Connecting the pipes to the indoor unit

The pipe can be connected to right side, bottom or back of the unit.

1. For the Right Side Piping

- After bending an end of the connecting tube, align the center of the pipings and sufficiently tighten the flare nut with fingers.
- Finally, tighten the flare nut with torque wrench until the wrench clicks.
- Connect the Drain Hose insulated to the drain outlet. Drain hose should go through under the Hose Bracket as shown in figure ④.
- Hang the drain hose on the hose hanger and fix it to the hole of the hose bracket with a screw.

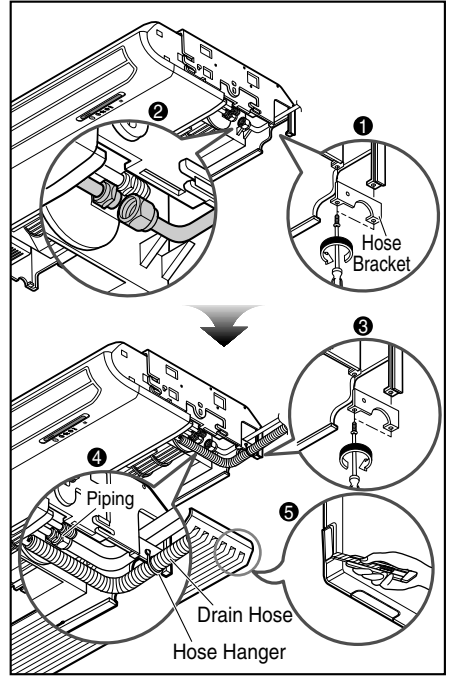

2. For the Bottom Side Piping

- Remove the knock-out on the bottomside of Inlet Grille
- Align the center of the pipings and sufficiently tighten the flare nut with fingers.
- Finally, tighten the flare nut with torque wrench until the wrench clicks.
- Connect the Drain Hose insulated to the drain outlet.
- Hang the drain hose on the hose hanger and fix it to the hole of cabinet bottom with a screw.

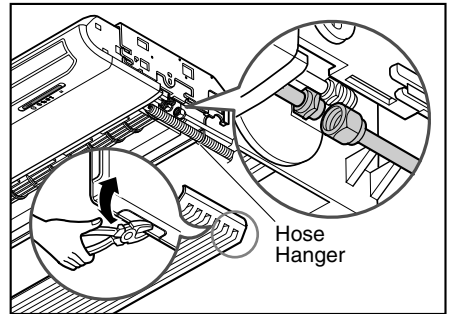

2) Connecting the Drain Hose

- The drain hose can be connected to not only the right side but also left side of the unit.
- If the drain hose is connected to the left side, it should go through the cabinet bottom.
- Hang the drain hose on the hose hanger and fix it to the hole of cabinet bottom with a screw.

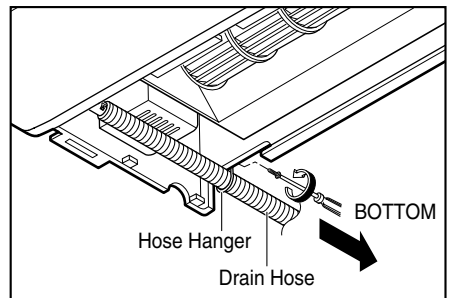

4. Installation on the wall or floor

1) Connecting the pipes to the indoor unit

1. For the Right Rear Piping

- Remove the knock-out at the back side of the cabinet.
- After bending an end of the connecting tube, align the center of the pipings and sufficiently tighten the flare nut with fingers.
- Finally, tighten the flare nut with torque wrench until the wrench clicks.
- Connect the Drain Hose insulated to the drain outlet.
- Tape the Drain Hose to the pipings to avoid coming off the drain-outlet.

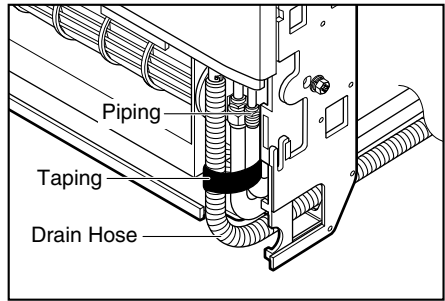

2. For the Right Side Piping

- After bending an end of the connecting tube, align the center of the pipings and sufficiently tighten the flare nut with fingers.
- Finally, tighten the flare nut with torque wrench until the wrench clicks.
- Connect the Drain Hose insulated to the drain outlet.
- Tape the Drain Hose to the pipings to avoid coming off the drain-outlet.

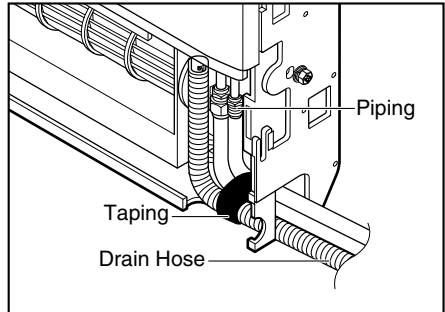

3. For the Right Bottom Piping

- Align the center of the pipings and sufficiently tighten the flare nut with fingers.
- Finally, tighten the flare nut with torque wrench until the wrench clicks.
- Connect the Drain Hose insulated to the drain outlet.

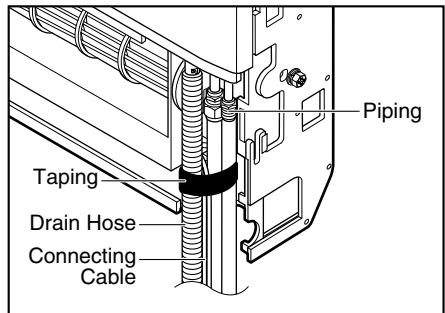

2) Connecting the Drain Hose

- The drain hose can be connected to not only right side but also left side of the unit.

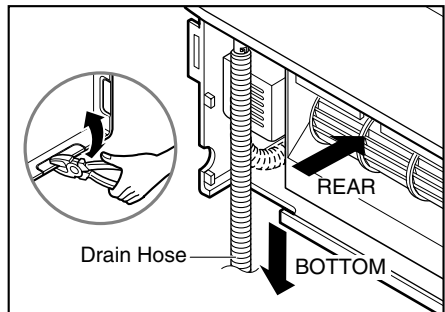

Connecting Pipes to the Outdoor Unit

■ Connecting the pipes to the Outdoor unit

1. **Align the center of the pipings and sufficiently tighten the flare nut with fingers.**
2. **Finally, tighten the flare nut with torque wrench until the wrench clicks.**

- When tightening the flare nut with torque wrench, ensure the direction for tightening follows the arrow on the wrench.

Outside diameter		Torque
mm	inch	kgf-cm
Ø6.35	1/4	180~250
Ø9.52	3/8	340~420
Ø12.7	1/2	550~660
Ø15.88	5/8	630~820
Ø19.05	3/4	990~1,210

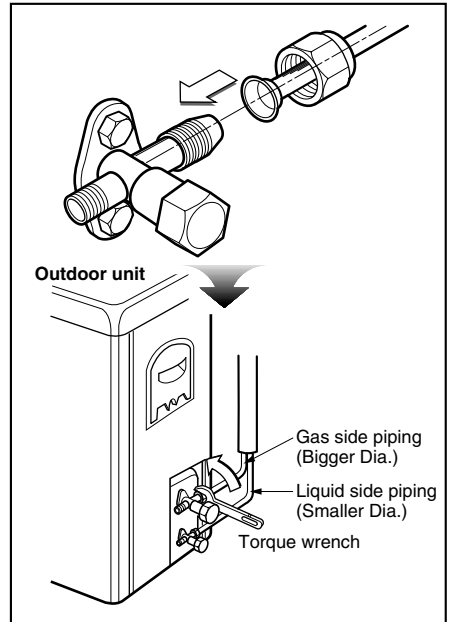

Checking the Drainage

■ VB CHASSIS

Checking the Drainage

1. **Remove the Air Filter.**

- To remove air filter, take hold of tab and pull slightly upwards.

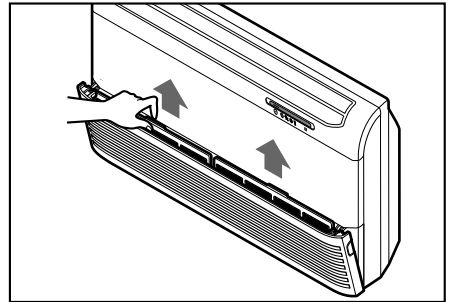

2. **Check the drainage.**

- Spray one or two glasses of water upon the evaporator.
- Ensure that water flows drain hose of indoor unit without any leakage.

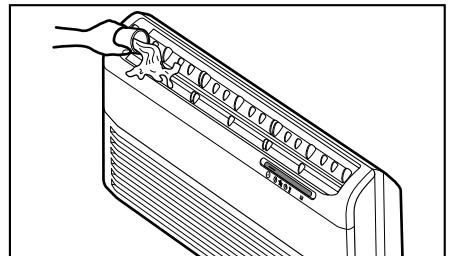

■ VK,VL,VJ CHASSIS

1) Checking the Drainage

1. Set the air direction louvers up-and-down to the position(horizontally) by hand.

2) To check the drainage.

1. Pour a glass of water on the evaporator using a kettle.
2. Ensure the water flows through the drain hose of the indoor unit without any leakage and goes out the drain exit.

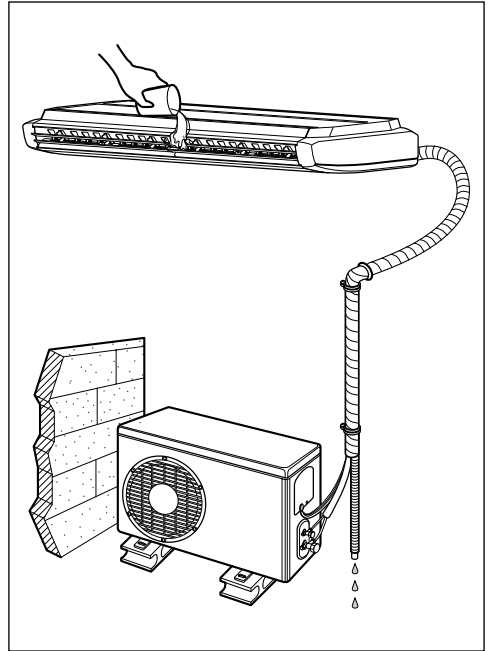

3) Drain piping

1. The drain hose should point downward for easy drain flow.

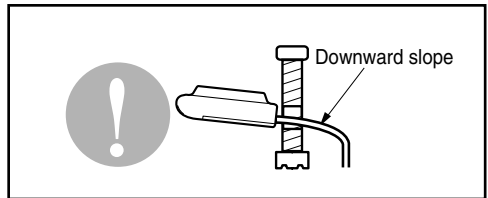

2. Do not make drain piping like the following.

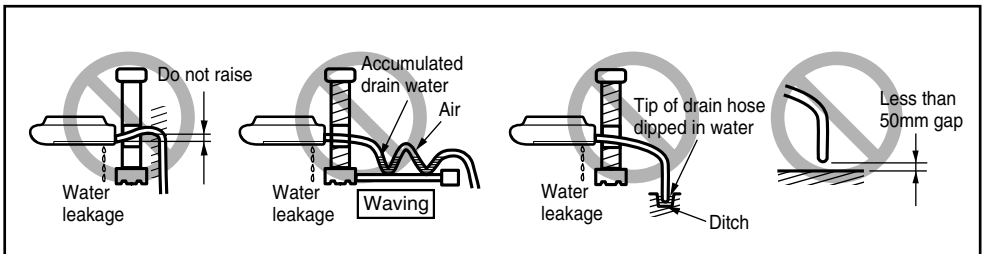

Connecting Cables between Indoor Unit and Outdoor Unit

1) Connecting cables to the Indoor Unit

- 1) Remove the Air guide - L by loosening 2 screws after removing the Inlet grille from the Indoor unit.
 - 2) Connect the wires to the terminals on the control board individually according to the outdoor unit connection.
- Ensure that the color of the wires of outdoor unit and the terminal No. are the same as those of indoor unit respectively

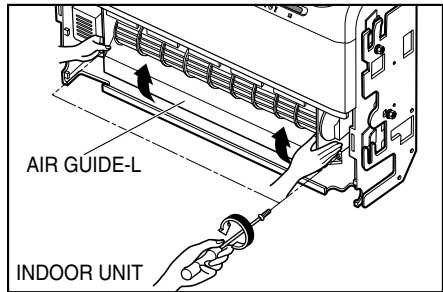

• Cooling Model Only

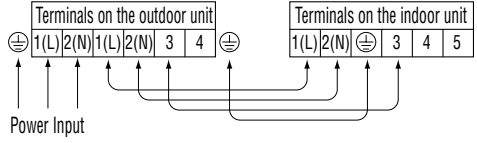

• Heat Pump Model Only

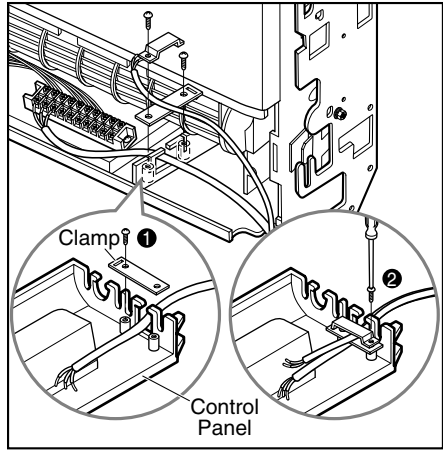
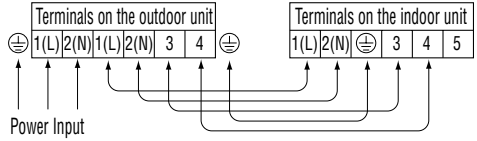

2) Clamping of cables

- 1) Arrange the connecting cable on the control panel.
- 2) First, fasten the steel clamp with a screw to the inner boss of control panel.
- 3) For the cooling model, fix the other side of the clamp with a screw strongly.
For the heat pump model, put the 0.75mm² cable (thinner cable) on the clamp and tighten it with a plastic clamp to the other boss of the control panel.
- 4) In Australia, the length of power supply cord measured from the entry of the power supply cord to the middle of live pin on the power plug should be over 1.8m.

The power cord connected to the outdoor unit should be complied with the following (Rubber insulation, type H07RN-F approved by HAR or SAA).

NORMAL CROSS-SECTIONAL AREA

- 3.0mm²(28K)
- 2.5mm²(24K)
- 2.0mm²(18K; for the Middle East)
- 1.5mm²(18K; for the other area)

CAUTION

The power connecting cable connected between the indoor and outdoor unit should be complied with the following specifications (Rubber insulation, type H05RN-F approved by HAR or SAA).

Cooling Only	4 x 0.75 (Including Earth)
Heat Pump	5 x 0.75 (Including Earth)

NORMAL CROSS-SECTIONAL AREA 0.75mm² (18k/24k/28k)

3) Connecting the cable to Outdoor Unit

1. Remove the Cover control from the unit by loosening a screw.
Connect the wires to the terminals on the control board individually as following.
2. Secure the cable onto the control board with the holder (clammer).
3. Refix the cover control to the original position with the screw.
4. Use a recognized circuit breaker between the power source and the unit. A disconnection device to adequately disconnect all supply lines must be fitted.

- Capacity of circuit breaker.

Circuit Breaker (A)	Grade		
	18k	24k	28k
30	30	30	

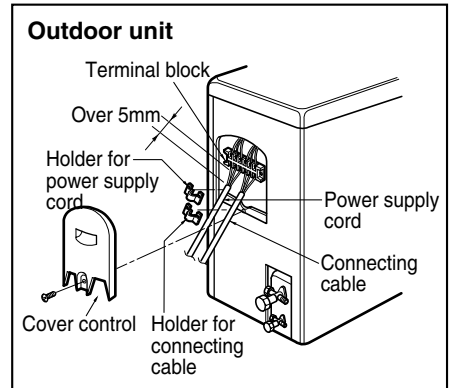

⚠ CAUTION

After the confirmation of the above conditions, prepare the wiring as follows:

- 1) **Never fail to have an individual power circuit specialized for the air conditioner. As for the method of wiring, be guided by the circuit diagram posted on the inside of control cover.**
- 2) **The screw which fasten the wiring in the casing of electrical fittings are liable to come loose from vibrations to which the unit is subjected during the course of transportation. Check them and make sure that they are all tightly fastened. (If they are loose, it could cause burn-out of the wires.)**
- 3) **Specification of power source.**
- 4) **Confirm that electrical capacity is sufficient.**
- 5) **See to it that the starting voltage is maintained at more than 90 percent of the rated voltage marked on the name plate.**
- 6) **Confirm the cable thickness which is specified as the power source specification. (Particularly note the relation between cable length and thickness.)**
- 7) **Always install an earth leakage circuit breaker in a wet or moist area.**
- 8) **The following would be caused by voltage drop.**
 - Vibration of a magnetic switch, which will damage the contact point, fuse breaking, disturbance of the normal function of the overload protection device.
- 9) **The means for disconnection from a power supply shall be incorporated in the fixed wiring and have an air gap contact separation of at least 3mm in each active(phase) conductors.**

4) Form the pipings

1. Wrap the connecting portion of indoor unit with the Insulation material and secure it with two Plastic Bands. (for the right pipings)

- If you want to connect an additional drain hose, the end of the drain-outlet should keep distance from the ground. (Do not dip it into water, and fix it on the wall to avoid swinging in the wind.)

In case of the Outdoor unit being installed below position of the Indoor unit.

2. Tape the Pipings, drain hose and Connecting Cable from bottom to top.

3. Form the pipings gathered by taping along the exterior wall and fix it onto the wall by saddle or equivalent.

In case of the Outdoor Unit being installed above position of the Indoor Unit.

2. Tape the Pipings and Connecting cable from bottom to top.

3. Form the pipings gathered by taping along the exterior wall, and make the trap prevent water from entering into the room.

4. Fix the pipings onto the wall by saddle or equivalent.

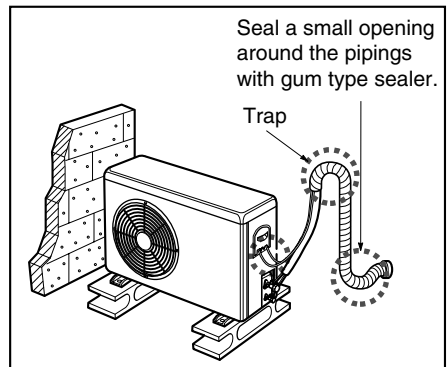
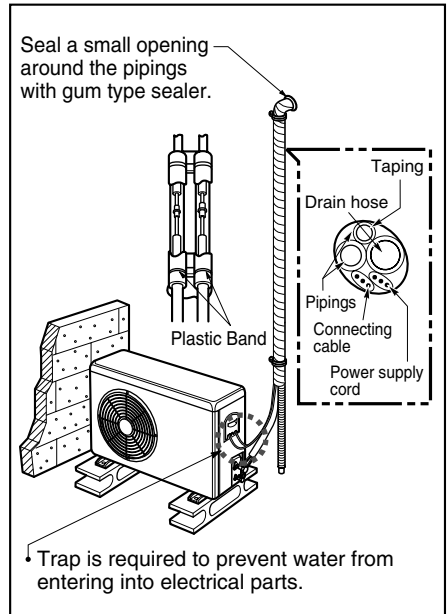

Air Purging of the Pipes and Indoor Unit

1) Air purging

Air and moisture remaining in the refrigerant system have undesirable effects as indicated below.

- Pressure in the system rises.
- Operating current rises.
- Cooling(or heating) efficiency drops.
- Moisture in the refrigerant circuit may freeze and block capillary tubing.
- Water may lead to corrosion of parts in the refrigeration system.

Therefore, the indoor unit and tubing between the indoor and outdoor unit must be leak tested and evacuated to remove any noncondensables and moisture from the system.

2) Air purging with vacuum pump

Preparation

- Check that each tube(both liquid and gas side tubes) between the indoor and outdoor units have been properly connected and all wiring for the test run has been completed. Remove the service valve caps from both the gas and the liquid side on the outdoor unit. Note that both the liquid and the gas side service valves on the outdoor unit are kept closed at this stage.

Leak test

- Connect the manifold valve(with pressure gauges) and dry nitrogen gas cylinder to this service port with charge hoses.

CAUTION

Be sure to use a manifold valve for air purging. If it is not available, use a stop valve for this purpose. The "Hi" knob of the manifold valve must always be kept close.

- Pressurize the system to no more than 150 P.S.I.G. with dry nitrogen gas and close the cylinder valve when the gauge reading reached 150 P.S.I.G. Next, test for leaks with liquid soap.

CAUTION

To avoid nitrogen entering the refrigerant system in a liquid state, the top of the cylinder must be higher than its bottom when you pressurize the system. Usually, the cylinder is used in a vertical standing position.

- Apply a soap water or a liquid neutral detergent on the indoor unit connection or outdoor unit connections by a soft brush to check for leakage of the connecting points of the piping. Do a leak test of all joints of the tubing(both indoor and outdoor) and both gas and liquid side service valves. If bubbles come out, the pipes have leakage. Be sure to wipe off the soap with a clean cloth.
- After the system is found to be free of leaks, relieve the nitrogen pressure by loosening the charge hose connector at the nitrogen cylinder. When the system pressure is reduced to normal, disconnect the hose from the cylinder.

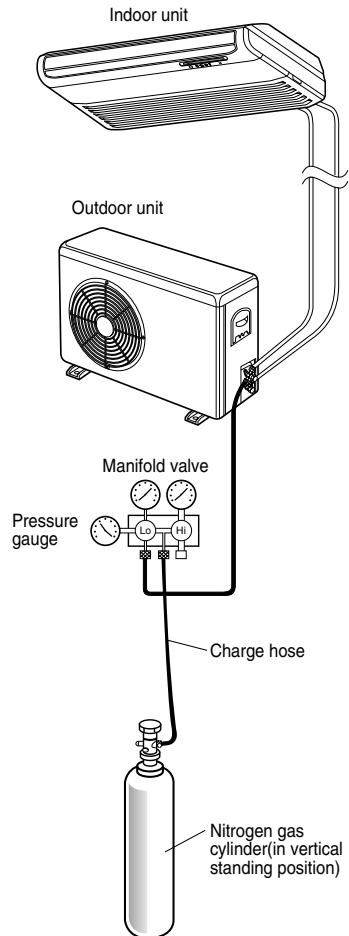

Evacuation

- Connect the charge hose end described in the preceding steps to the vacuum pump to evacuate the tubing and indoor unit. Confirm the "Lo" knob of the manifold valve is open. Then, run the vacuum pump. The operation time for evacuation varies with tubing length and capacity of the pump. The following table shows the time required for evacuation.

Required time for evacuation when 30 gal/h vacuum pump is used	
If tubing length is less than 10m (33 ft)	if tubing length is longer than 10m (33 ft)
10 min. or more	15 min. or more

- When the desired vacuum is reached, close the "Lo" knob of the manifold valve and stop the vacuum pump.

CAUTION

Use vacuum pump equipped with check valve applied to be prevented from flowing backward.

Finishing the job

- With a service valve wrench, turn the valve stem of liquid side valve counter-clockwise to fully open the valve.
- Turn the valve stem of gas side valve counter-clockwise to fully open the valve.
- Loosen the charge hose connected to the gas side service port slightly to release the pressure, then remove the hose.
- Replace the flare nut and its bonnet on the gas side service port and fasten the flare nut securely with an adjustable wrench. This process is very important to prevent leakage from the system.
- Replace the valve caps at both gas and liquid side service valves and fasten them tight. This completes air purging with a vacuum pump. The air conditioner is now ready to test run.

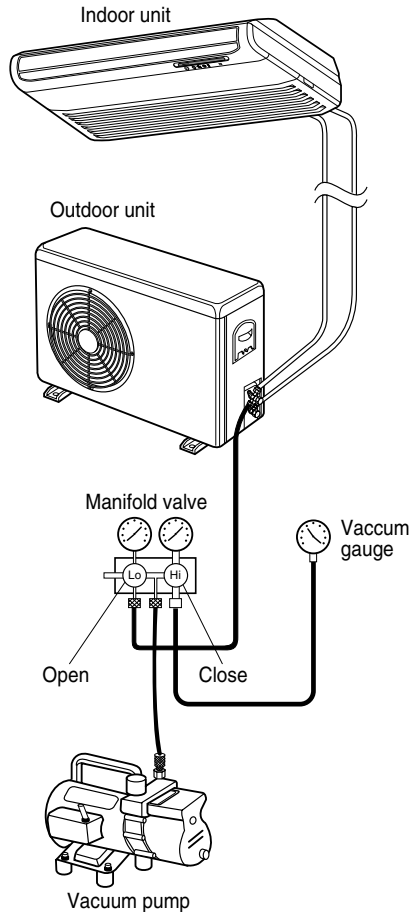
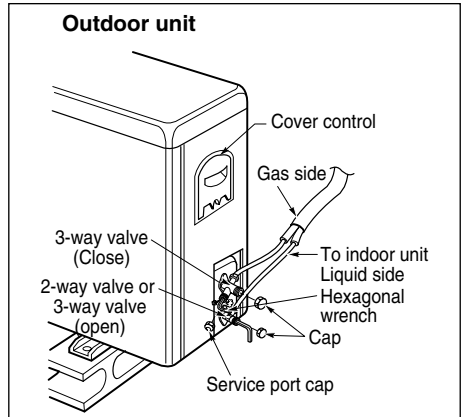

Test running

1) Connection of power supply

1. Connect the power supply cord to the independent power supply.

- Circuit breaker is required.

2. Prepare the remote control.

- Insert two batteries provided.
Remove the battery cover from the remote controller.
- Slide the cover according to the arrow direction.
Insert the two batteries.
(Two "R03" or "AAA" dry-cell batteries or equivalent.)
- Be sure that the (+) and (-) directions are correct.
- Be sure that both batteries are new.
Re-attach the cover.
- Slide it back into position.

3. Operate the unit for fifteen minutes or more.

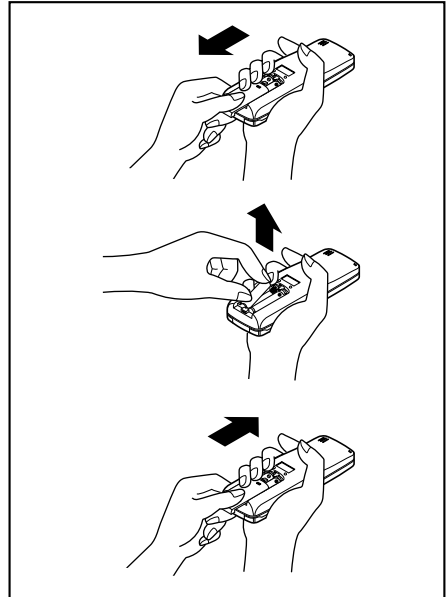

2) Evaluation of the performance

1. Measure the temperature of the intake and discharge air.

2. Ensure the difference between the intake temperature and the discharge one is more than 8°C (Cooling) or reversely (Heating).

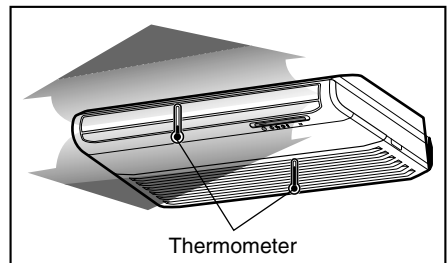

Installation guide at the seaside

⚠ CAUTION

1. Air conditioners should not be installed in areas where corrosive gases, such as acid or alkaline gas, are produced.
2. Do not install the product where it could be exposed to sea wind (salty wind) directly. It can result corrosion on the product. Corrosion, particularly on the condenser and evaporator fins, could cause product malfunction or inefficient performance.
3. If outdoor unit is installed close to the seaside, it should avoid direct exposure to the sea wind. Otherwise it needs additional anticorrosion treatment on the heat exchanger.

Selecting the location(Outdoor Unit)

- 1) If the outdoor unit is to be installed close to the seaside, direct exposure to the sea wind should be avoided. Install the outdoor unit on the opposite side of the sea wind direction.

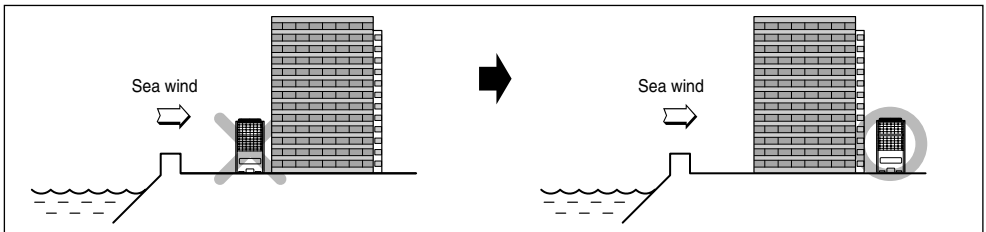

- 2) In case, to install the outdoor unit on the seaside, set up a windbreak not to be exposed to the sea wind.

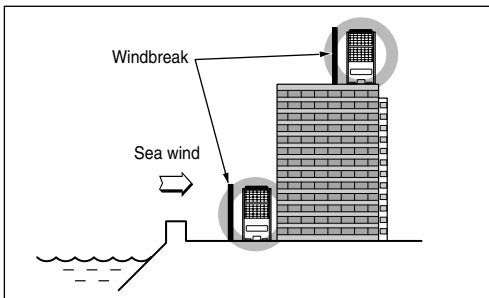

- It should be strong enough like concrete to prevent the sea wind from the sea.
- The height and width should be more than 150% of the outdoor unit.
- It should be kept more than 70 cm of space between outdoor unit and the windbreak for easy air flow.

- 3) Select a well-drained place.

1. If you can't meet above guide line in the seaside installation, please contact LG Electronics for the additional anticorrosion treatment.
2. Periodic (more than once/year) cleaning of the dust or salt particles stuck on the heat exchanger by using water

