



**LG**

Life's Good

ENGLISH

ESPAÑOL

# INSTALLATION MANUAL

# AIR CONDITIONER

- Please read this installation manual completely before installing the product.
- Installation work must be performed in accordance with the national wiring standards by authorized personnel only.
- Please retain this installation manual for future reference after reading it thoroughly.

**TYPE : Ceilling Concealed Duct**

# CONTENTS

<b>Safety Precautions</b> .....	<b>3</b>
<b>Introduction</b> .....	<b>6</b>
<b>Installation of Indoor, Outdoor Unit</b> .....	<b>7</b>
<b>Connecting Pipes to the Indoor Unit</b> .....	<b>18</b>
<b>Connecting Pipes to the Outdoor Unit</b> .....	<b>20</b>
<b>Checking the Drainage</b> .....	<b>20</b>
<b>Connecting Cables between Indoor Unit and Outdoor Unit</b> .....	<b>21</b>
<b>Air Purging and Evacuation</b> .....	<b>24</b>
<b>Group Control</b> .....	<b>26</b>
<b>Two Thermistor system</b> .....	<b>27</b>
<b>E.S.P.(External Static Pressure) Setting</b> .....	<b>28</b>
<b>How to Set E.S.P?</b> .....	<b>30</b>
<b>External Static Pressure &amp; air Flow</b> .....	<b>31</b>
<b>Test Running</b> .....	<b>32</b>
<b>Accessory Installation Guide</b> .....	<b>34</b>
<b>Installation guide at the seaside</b> .....	<b>38</b>

# Safety Precautions



To prevent injury to the user or other people and property damage, the following instructions must be followed.

- Incorrect operation due to ignoring instruction will cause harm or damage. The seriousness is classified by the following indications.

**⚠ WARNING** This symbol indicates the possibility of death or serious injury.

**⚠ CAUTION** This symbol indicates the possibility of injury or damage.

- Meanings of symbols used in this manual are as shown below.

	<b>Be sure not to do.</b>
	<b>Be sure to follow the instruction.</b>

## ⚠ WARNING

### ■ Installation

**Do not use a defective or underrated circuit breaker. Use this appliance on a dedicated circuit.**

- There is risk of fire or electric shock.

**For electrical work, contact the dealer, seller, a qualified electrician, or an Authorized Service Center.**

- Do not disassemble or repair the product. There is risk of fire or electric shock.

**Always ground the product.**

- There is risk of fire or electric shock.

**Install the panel and the cover of control box securely.**

- There is risk of fire or electric shock.

**Always install a dedicated circuit and breaker.**

- Improper wiring or installation may cause fire or electric shock

**Use the correctly rated breaker or fuse.**

- There is risk of fire or electric shock.

**Do not modify or extend the power cable.**

- There is risk of fire or electric shock.

**Do not install, remove, or re-install the unit by yourself (customer).**

- There is risk of fire, electric shock, explosion, or injury.

**Be cautious when unpacking and installing the product.**

- Sharp edges could cause injury. Be especially careful of the case edges and the fins on the condenser and evaporator.

**For installation, always contact the dealer or an Authorized Service Center.**

- There is risk of fire, electric shock, explosion, or injury.

**Do not install the product on a defective installation stand.**

- It may cause injury, accident, or damage to the product.

**Be sure the installation area does not deteriorate with age.**

- If the base collapses, the air conditioner could fall with it, causing property damage, product failure, and personal injury.

**Do not let the air conditioner run for a long time when the humidity is very high and a door or a window is left open.**

- Moisture may condense and wet or damage furniture.

## ■ Operation

**Do not touch(operate) the product with wet hands.**

- There is risk of fire or electrical shock.

**Do not place a heater or other appliances near the power cable.**

- There is risk of fire and electric shock.

**Do not let electric parts of the product get wet.**

- It may cause There is risk of fire, failure of the product, or electric shock.

**Do not store or use flammable gas or combustibles near the product.**

- There is risk of fire or failure of product.

**If strange sounds, or small or smoke comes from product. Turn the breaker off or disconnect the power supply cable.**

- There is risk of electric shock or fire.

**When the product is soaked (flooded or submerged), contact an Authorized Service Center.**

- There is risk of fire or electric shock.

**Be cautious that water could not enter the product.**

- There is risk of fire, electric shock, or product damage.

**Turn the main power off when cleaning or maintaining the product.**

- There is risk of electric shock.

**When the product is not be used for a long time, disconnect the power supply plug or turn off the breaker.**

- There is risk of product damage or failure, or unintended operation.

**Take care to ensure that nobody could step on or fall onto the outdoor unit.**

- This could result in personal injury and product damage.

## CAUTION

## ■ Installation

**Always check for gas (refrigerant) leakage after installation or repair of product.**

- Low refrigerant levels may cause failure of product.

**Install the drain hose to ensure that water is drained away properly.**

- A bad connection may cause water leakage.

**Keep level even when installing the product.**

- To avoid vibration.

**Do not install the product where the noise or hot air from the outdoor unit could be offensive to the neighborhoods or damage property.**

- It may cause a problem for your neighbors.

**Use two or more people to lift and transport the product.**

- Avoid personal injury.

**Do not install the product where it will be exposed to sea wind (salt spray) directly.**

- It may cause corrosion on the product. Corrosion, particularly on the condenser and evaporator fins, could cause product malfunction or inefficient operation.

## ■ Operation

**Do not expose the skin directly to cool air for long periods of time. (Don't sit in the draft.)**

- This could harm to your health.

**Do not use the product for special purposes, such as preserving foods, works of art, etc. It is a consumer air conditioner, not a precision refrigeration system.**

- There is risk of damage or loss of property.

**Do not block the inlet or outlet of air flow.**

- It may cause product failure.

**Use a soft cloth to clean. Do not use harsh detergents, solvents, etc.**

- There is risk of fire, electric shock, or damage to the plastic parts of the product.

**Do not step on or put anything on the product. (outdoor units)**

- There is risk of personal injury and failure of product.

**Do not insert hands or other objects through the air inlet or outlet while the product is operated.**

- There are sharp and moving parts that could cause personal injury.

**Do not drink the water drained from the product.**

- It is not sanitary and could cause serious health issues.

**Use a firm stool or ladder when cleaning or maintaining the product.**

- Be careful and avoid personal injury.

**Replace the all batteries in the remote control with new ones of the same type. Do not mix old and new batteries or different types of batteries.**

- Could adversely affect operation.

**Do not recharge or disassemble the batteries. Do not dispose of batteries in a fire.**

- They may burn or explode.

**If the liquid from the batteries gets onto your skin or clothes, wash it well with clean water. Do not use the remote if the batteries have leaked.**

- The chemicals in batteries could cause burns or other health hazards.

# Introduction

## Symbols Used in this Manual



This symbol alerts you to the risk of electric shock.



This symbol alerts you to hazards that could cause harm to the air conditioner.

**NOTICE**

This symbol indicates special notes.

## Features

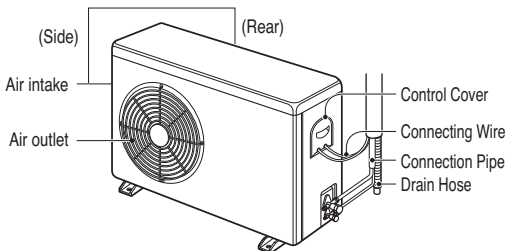
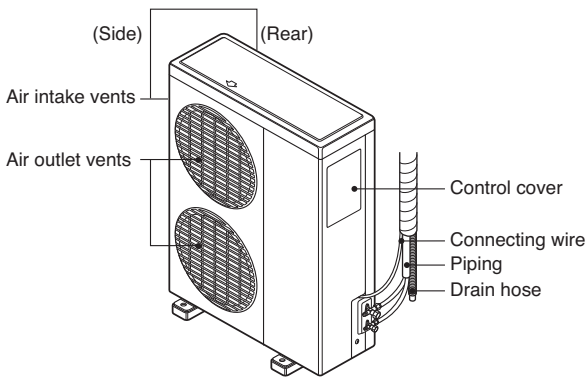
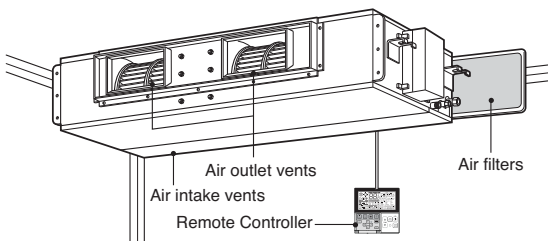

# Installation of Indoor, Outdoor Unit

## Selection of the best location

### Indoor unit

Install the air conditioner in the location that satisfies the following conditions.

- The place shall easily bear a load exceeding four times the indoor unit's weight.
- The place shall be able to inspect the unit as the figure.
- The place where the unit shall be leveled.
- The place shall allow easy water drainage. (Suitable dimension "H" is necessary to get a slope to drain as figure.)
- The place shall easily connect with the outdoor unit.
- The place where the unit is not affected by an electrical noise.
- The place where air circulation in the room will be good .
- There should not be any heat source or steam near the unit

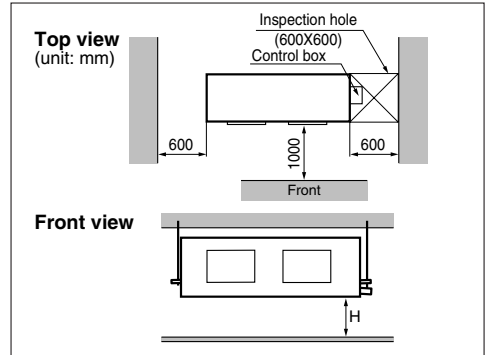

### Outdoor unit

- If an awning is built over the unit to prevent direct sunlight or rain exposure, be careful that heat radiation from the condenser is not restricted.
- There should not be any animals or plants which could be affected by hot air discharged.
- Ensure the spaces indicated by arrows from the wall, ceiling, fence or other obstacles.

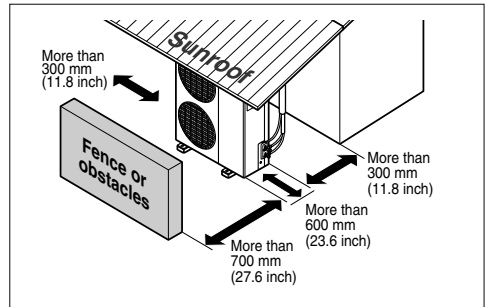

## Piping length and the elevation

Capacity	Pipe Size (Diameter:Ø)		Length A(m)		Elevation B(m)		*Additional refrigerant(g/m)
	Gas	Liquid	Standard	Max.	Standard	Max.	
18 kBtu/h	15.88mm(5/8")	6.35mm(1/4")	7.5	50	5	30	40
24 kBtu/h	15.88mm(5/8")	6.35mm(1/4")	7.5	50	5	30	30
30 kBtu/h	15.88mm(5/8")	6.35mm(1/4")	7.5	50	5	30	45
36 kBtu/h	15.88mm(5/8")	6.35mm(1/4")	7.5	50	5	30	45
48 kBtu/h	19.05mm(3/4")	9.52mm(3/8")	7.5	50	7.5	30	60
60 kBtu/h	19.05mm(3/4")	9.52mm(3/8")	7.5	50	7.5	30	55

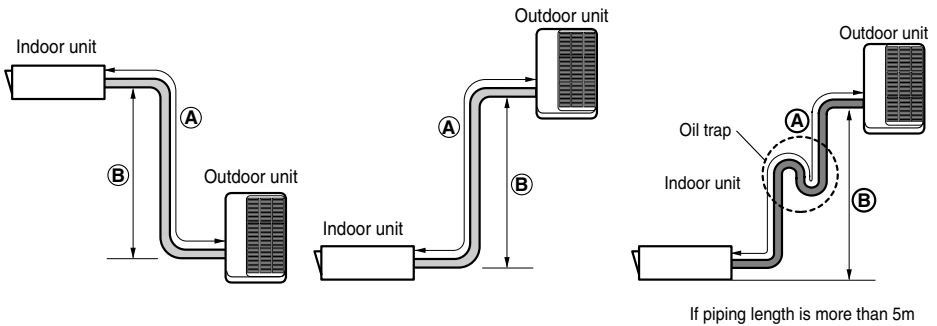

### CAUTION:

- If 48 kBtu Model is installed at a distance of 15m, 450g of refrigerant should be added  $(15-7.5) \times 60g = 450g$
- Capacity is based on standard length and maximum allowance length is on the basis of reliability.
- Improper refrigerant charge may result in abnormal cycle.
- Oil trap should be installed every 10 meters.

## Indoor unit installation

### Installation of Unit

Install the unit above the ceiling correctly.

#### CASE 1

##### POSITION OF SUSPENSION BOLT

- Apply a joint-canvas between the unit and duct to absorb unnecessary vibration.
- Apply a filter Accessory at air return hole.

(Unit : mm)

Dimension Capacity	A	B	C	D	E	F	G	H	I	J
18/24 kBTu/h (BH Chassis)	932	882	355	45.5	450	30	87	750	163	260
30/36 kBTu/h (BG Chassis)	1232	1182	355	45.5	450	30	87	830	186	298
48/60 kBTu/h (BR Chassis)	1282	1230	477	56	590	30	120	1006	294	380

- Install the unit leaning to a drainage hole side as a figure for easy water drainage.

#### CASE 2

##### POSITION OF CONSOLE BOLT

- A place where the unit will be leveled and that can support the weight of the unit.
- A place where the unit can withstand its vibration.
- A place where service can be easily performed.

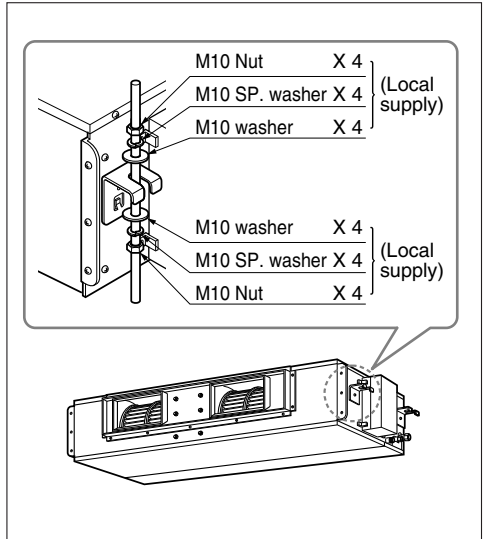
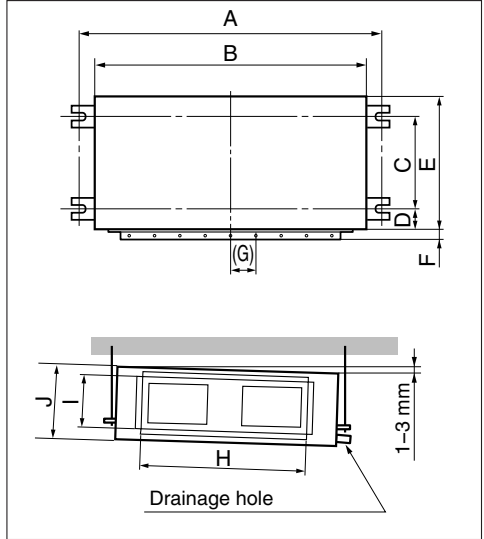

- Select and mark the position for fixing bolts.
- Drill the hole for set anchor on the face of ceiling.

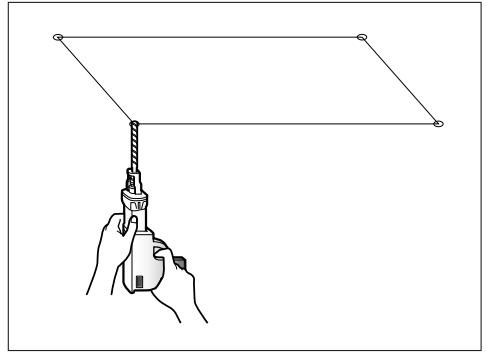

- Insert the set anchor and washer onto the suspension bolts for locking the suspension bolts on the ceiling.
- Mount the suspension bolts to the set anchor firmly.
- Secure the installation plates onto the suspension bolts (adjust level roughly) using nuts, washers and spring washers.

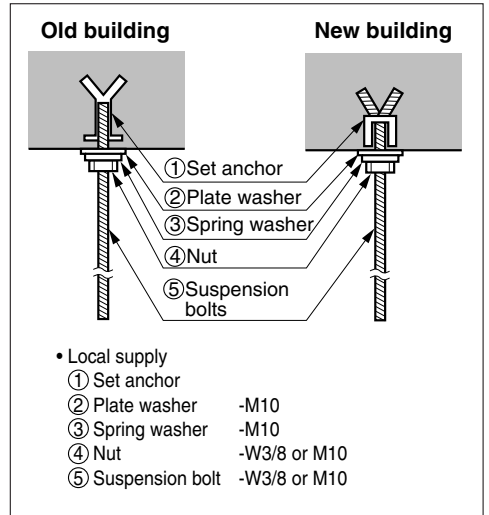

**CAUTION:**  
**Tighten the nut and bolt to prevent unit falling.**

## CAUTION

1. Install declination of the indoor unit is very important for the drain of the duct type air conditioner.
2. Minimum thickness of the insulation for the connecting pipe shall be 10 mm.

### Front of view

- The unit must be declined to the drain hose connected when finished installation.

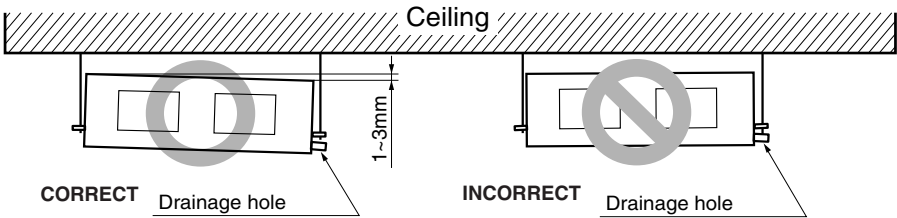

### CAUTION FOR GRADIENT OF UNIT AND DRAIN PIPING

Lay the drain hose with a downward inclination so water will drain out.

- Always lay the drain with downward inclination (1/50 to 1/100). Prevent any upward flow or reverse flow in any part.
- 5 mm or thicker formed thermal insulator shall always be provided for the drain pipe.

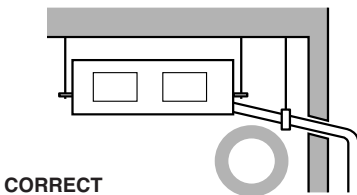
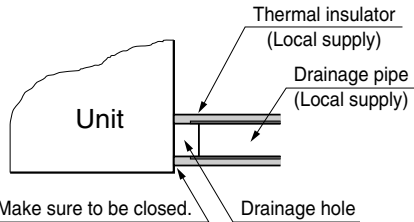

**CORRECT**

- Upward routing not allowed

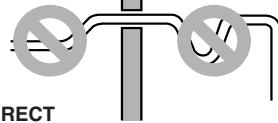

**INCORRECT**

#### Applied U-Trap Dimension

- A ≥ 70 mm
- B ≥ 2C
- C ≥ 2 x SP
- SP = External Pressure (mmAq)
- Ex) External Pressure = 10 mmAq
- A ≥ 70 mm
- B ≥ 40 mm
- C ≥ 20 mm

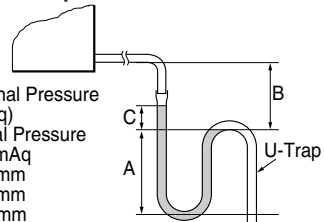

- Install the P-Trap (or U-Trap) to prevent a water leakage caused by the blocking of intake air filter.

- Drill the piping hole with 70 mm dia, hole core drill.
- Piping hole should be slightly slant to the outdoor side.

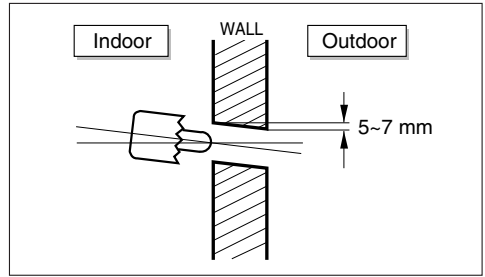

## INSULATION, OTHERS

Insulate the joint and tubes completely.

### THERMAL INSULATION

All thermal insulation must comply with local requirement.

### INDOOR UNIT

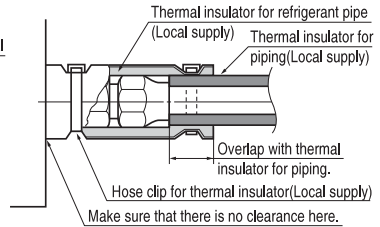
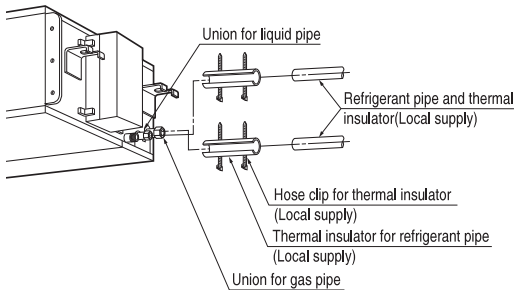

### REFRIGERANT PIPE

- Insulate and tape the gas piping.



**CAUTION: Cutting line of insulation must look upper direction. Thickness of insulation is 7mm or over.**

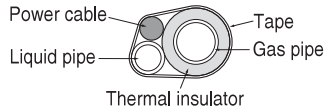

**NOTICE** Recommended Insulation

material

Material: FOAM PE

Thickness : 10mm

Density : less than  $0.032 \pm 0.005$  (g/cm<sup>3</sup>)

Thermal conductivity : less than  $0.03$  (kcal/m.hr.°C)

### TEST AND CHECK

■ **After all workings are finished, check the working and operation.**

- Air distribution \_\_\_\_\_ Is the air circulation good?
- Drain \_\_\_\_\_ Is the drainage smoothly and no sweating?
- Gas leakage \_\_\_\_\_ Is the piping connection correctly?
- Wiring \_\_\_\_\_ Is the wiring connection correctly?
- Lock-bolt \_\_\_\_\_ Is the lock-bolt of compressor loosened?

## Remote Controller Installation

### 1. Please fix tightly using provided screw after placing remote controller setup board on the place where you like to setup.

- Please set it up not to bend because poor setup could take place if setup board bends. Please set up remote controller board fit to the reclamation box if there is a reclamation box.
- Install the product so as not to make a gap with the wall side and to prevent shaking after the installation.

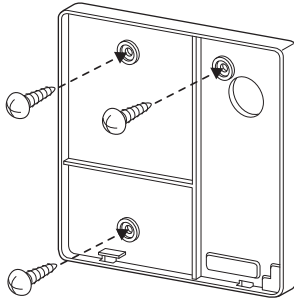

### 2. Can set up Wired remote controller cable into three directions.

- Setup direction: the surface of wall reclamation, upper, right
- If setting up remote controller cable into upper and right side, please set up after removing remote controller cable guide groove.

※ Remove guide groove with long nose.

#### ① Reclamation to the surface of the wall

#### ② Upper part guide groove

#### ③ Right part guide groove

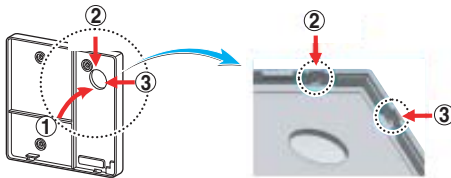

<Wire guide grooves>

**3. Please fix remote controller upper part into the setup board attached to the surface of the wall, as the picture below, and then, connect with setup board by pressing lower part.**

- Please connect not to make a gap at the remote controller and setup board's upper and lower, right and left part.
- Before assembly with the installation board, arrange the Cable not to interfere with circuit parts.

<Connecting order>

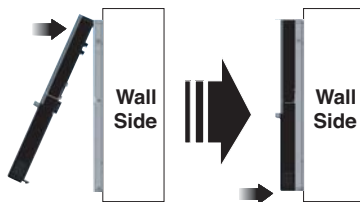

<Separating order>

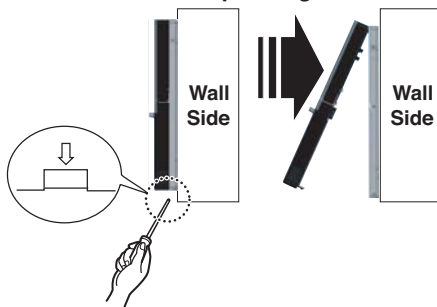

**When separating remote controller from setup board, as the picture below, after inserting into the lower separating hole using screw driver and then, spinning clockwise, remote controller is separated.**

- There are two separating holes. Please individually separate one at a time.
- Please be careful not to damage the inside components when separating.

**4. Please connect indoor unit and remote controller using connection cable.**

12V	Red
Signal	Yellow
GND	Black

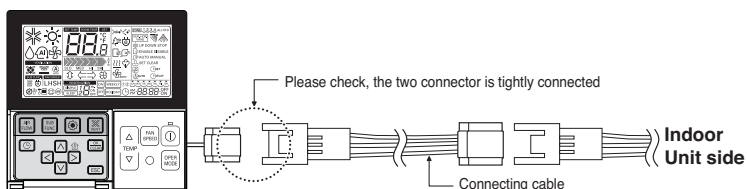

**5. Please use extension cable if the distance between wired remote controller and indoor unit is more than 10m.**

**⚠ CAUTION**

**When installing the wired remote controller, do not bury it in the wall.**

**(It can cause damage in the temperature sensor.)**

**Do not install the cable to be 50m or above.**

**(It can cause communication error.)**

- When installing the extension cable, check the connecting direction of the connector of the remote controller side and the product side for correct installation.
- If you install the extension cable in the opposite direction, the connector will not be connected.
- Specification of extension cable: 2547 1007 22# 2 core 3 shield 5 or above.

- Since the room temperature sensor is in the remote controller, the remote controller box should be installed in a place away from direct sunlight, high humidity and direct supply of cold air to maintain proper space temperature. Install the remote controller about 5ft(1.5m) above the floor in an area with good air circulation at an average temperature.

**Do not install the remote controller where it can be affected by:**

- Drafts, or dead spots behind doors and in corners.
- Hot or cold air from ducts.
- Radiant heat from sun or appliances.
- Concealed pipes and chimneys.
- Uncontrolled areas such as an outside wall behind the remote controller.
- This remote controller is equipped with a seven segment LED. display. For proper display of the remote controller LED's, the remote controller should be installed properly as shown in Fig.1. (The standard height is 1.2~1.5 m from floor level.)

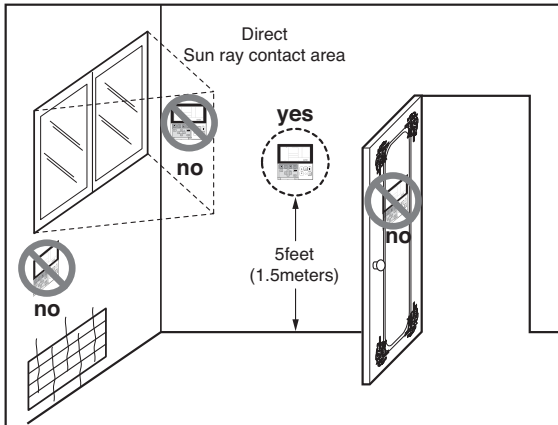
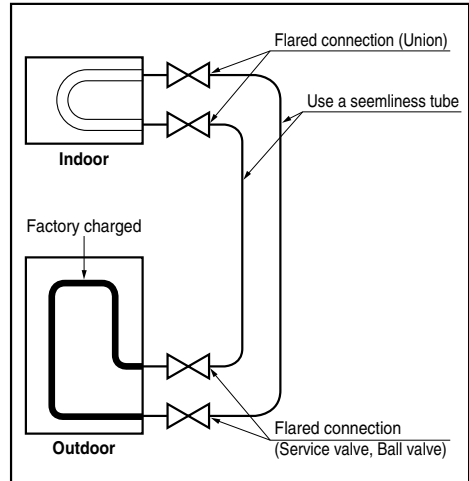

**Fig.1 Typical locations for remote controller**

## REFRIGERANT PIPING

Perform the work according to the Service Manual or Installation Guide.

- Use two spanners when connecting the refrigerant pipe to the unit.
- Make a bend with a radius as large as possible.
- Perform air purge with R-22 or vacuum drying.
- When piping work is finished, check all joints.



## INSTALLATION OF OUT DOOR UNIT

Select a location that satisfies the following conditions. Install the unit firmly in place.

### ■ Select the following location

- A place where the air conditioner can get good ventilation.
- A place where it shall not annoy the neighbors.
- A place where the unit shall be leveled and that can support the weight of unit and withstand its vibrations.

### ■ Keep a maintenance space

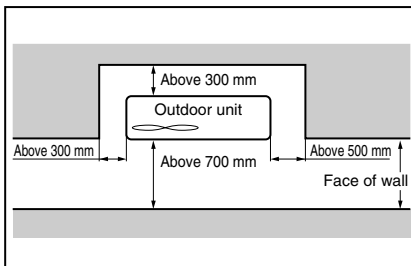

## ELECTRICAL WIRING

Perform the electrical wiring work according to the electrical wiring connection.

- All wiring must comply with local requirements.
- Select a power source that is capable of supplying the current required by the air conditioner.
- Use a recognized circuit breaker between the power source and the unit. A disconnection device to adequately disconnect all supply lines must be fitted.
- Capacity of circuit breaker

Capacity	1 Phase
18 kBTu/h	25A
24 kBTu/h	25A
30 kBTu/h	30A
36 kBTu/h	35A
48 kBTu/h	40A
60 kBTu/h	50A

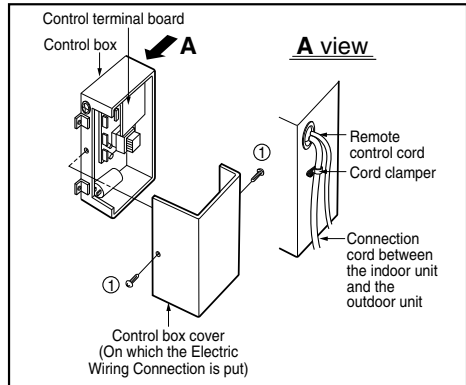
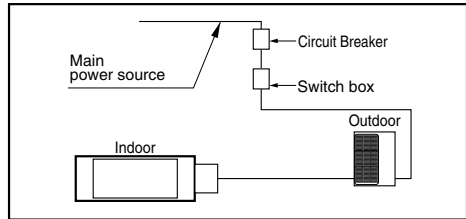

### WIRING CONNECTION

#### Indoor unit

- Remove the control box cover for electrical connection between the indoor and outdoor unit.  
(Remove crews ①)
- Use the cord clamber to fix the cord.

#### Outdoor unit

- Remove the control cover for wiring connection.
- Use the cord clamber to fix the cord.
- Earthing work  
Connect the cable of diameter 1.6mm<sup>2</sup> or more to the earthing terminal provided in the control box and do earthing.

※ Please check !!

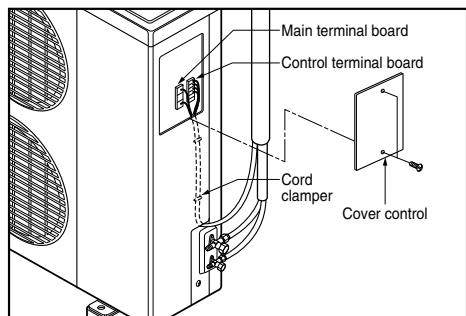

# Connecting Pipes to the Indoor Unit

## Preparation of Piping

Main cause of gas leakage is defect in flaring work. Carry out correct flaring work in the following procedure.

### Cut the pipes and the cable.

- Use the accessory piping kit or the pipes purchased locally.
- Measure the distance between the indoor and the outdoor unit.
- Cut the pipes a little longer than measured distance.
- Cut the cable 1.5m longer than the pipe length.

### Burrs removal

- Completely remove all burrs from the cut cross section of pipe/tube.
- Put the end of the copper tube/pipe to downward direction as you remove burrs in order to avoid to let burrs drop in the tubing.

### Putting nut on

- Remove flare nuts attached to indoor and outdoor units, than put them on pipe/tube having completed burr removal. (Not possible to put them on after flaring work)

### Flaring work

- Carry out flaring work using flaring tool as shown below.

Outside Diameter	"A"
6.35 mm (1/4")	1.1~1.3 mm
9.52 mm (3/8")	1.5~1.7 mm
12.7 mm (1/2")	1.6~1.8 mm
15.88 mm (5/8")	1.6~1.8 mm
19.05 mm (3/4")	1.9~2.1 mm

Firmly hold copper tube in a bar(or die) as indicated dimension in the table above.

### Check

- Compare the flared work with figure.
- If flare is noted to be defective, cut off the flared section and do flaring work again.

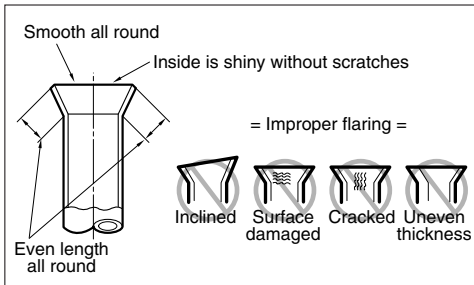
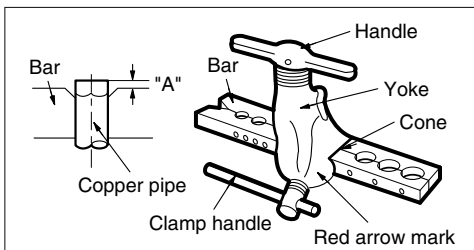
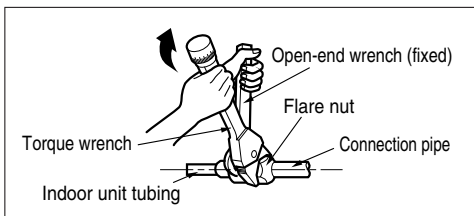
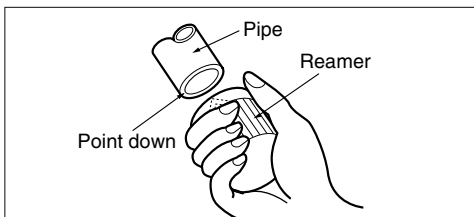
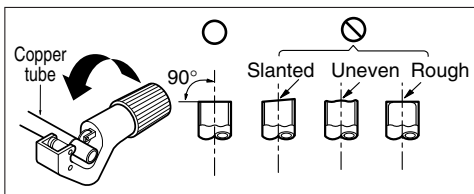

## Pipe bending

Annealed copper pipe with small diameter ( $\phi 6.35$  or  $\phi 9.52$ ) can be easily bent manually. In this case, secure large R(radius) for the bend section and gradually bend pipe. If annealed copper pipe is large in diameter ( $\phi 15.88$  or  $\phi 19.05$ ), bend pipe with bender. Use bender appropriate for the pipe diameter.

## Brazing

In refrigerant piping, bending (in particular, acute bending) must be minimized to reduce piping resistance. Bending is, however, necessary in some places by virtue of the installation position of devices auxiliary to the packaged air conditioner, or of the building structure, piping distance or finishing appearance. If a more acute bend is required than that attainable by pipe bender, perform brazing using ready-made elbow. Aside from this function, brazing also serves to connect straight pipes, generally using ready-made sockets. While brazing, protect piping against heat with wet cloth to avoid damaging valve packing or burning thermal insulator with burner heat. While brazing, blow inert gas (nitrogen gas or carbonic gas) to prevent formation of oxidation film in copper piping; otherwise, the refrigerant circuit will clog. The blowing of nitrogen gas (or carbonic gas) through 3-way valves is described in the following:

## Refrigerant piping(Flare piping)

When connecting piping, be sure to keep piping dry(keep piping away from water), clean (keep piping away from dust) and airtight (avoid refrigerant leakage).

When connecting piping on rainy days or making a through-hole in wall, take due care to prevent water or plaster from entering piping.

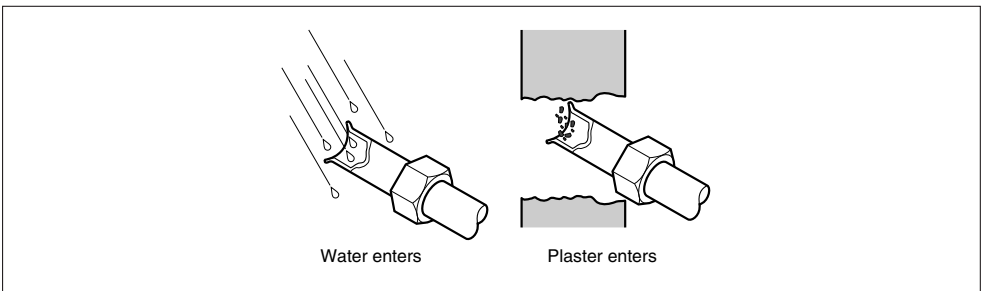

### CAUTION:

- This procedure is designed to prevent formation of oxidation film by filling piping with inert gas. Note that excessive gas pressure will generate pinholes at brazed points.  
(Nitrogen gas: Supply pressure 0.05~0.1kg/cm<sup>2</sup>G)
- When supplying inert gas, be sure to open one end of piping.

## Connecting Pipes to the Outdoor Unit

### Connecting the pipes to the Outdoor unit

- Align the center of the pipings and sufficiently tighten the flare nut with fingers.
- Finally, tighten the flare nut with torque wrench until the wrench clicks.
  - When tightening the flare nut with torque wrench, ensure the direction for tightening follows the arrow on the wrench.

Pipe size	Torque (kgf.m)
6.35 mm (1/4")	1.8~2.5
9.52 mm (3/8")	3.4~4.2
12.7 mm (1/2")	5.5~6.6
15.88 mm (5/8")	6.3~8.2
19.05 mm (3/4")	9.9~12.1

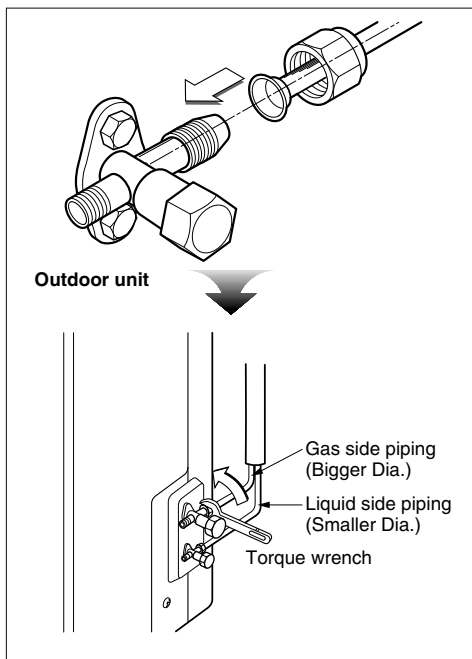

## Checking the Drainage

### Checking the Drainage

- Remove the Air Filter.

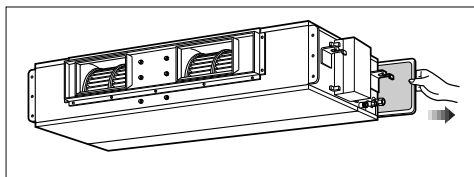

- Check the drainage.
  - Spray one or two glasses of water upon the evaporator.
  - Ensure that water flows drain hose of indoor unit without any leakage.

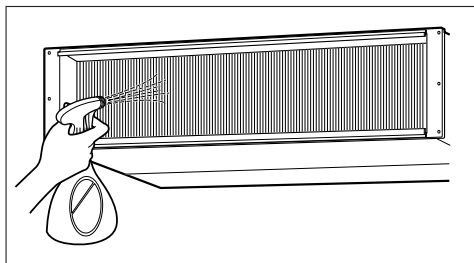

# Connecting Cables between Indoor Unit and Outdoor Unit

## Connecting cables to the Indoor Unit

- Connect the wires to the terminals on the control board individually according to the outdoor unit connection.
  - Ensure that the color of the wires of outdoor unit and the terminal No. are the same as those of indoor unit respectively

### ■ Cooling only Model

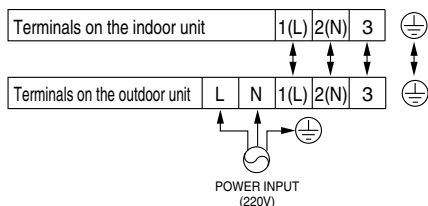

### ■ Heat pump Model

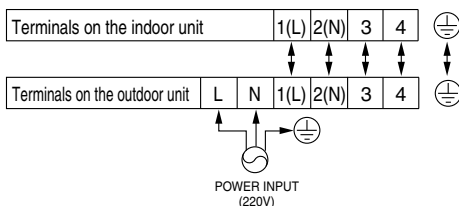

**The power cord** connected to the outdoor unit should be complied with the following specifications (Rubber insulation, type H05RN-F approved by HAR or SAA).

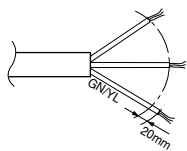

#### NORMAL CROSS-SECTIONAL AREA

Capacity	1 Phase
18 kBTu/h	2.5 mm <sup>2</sup>
24 kBTu/h	2.5 mm <sup>2</sup>
30 kBTu/h	3.5 mm <sup>2</sup>
36 kBTu/h	5.5 mm <sup>2</sup>
48 kBTu/h	8.5 mm <sup>2</sup>
60 kBTu/h	8.5 mm <sup>2</sup>

#### CAUTION

**The connecting cable** connected to the indoor and outdoor unit should be complied with the following specifications (Rubber insulation, type H05RN-F approved by HAR or SAA).

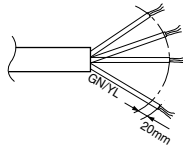

NORMAL  
CROSS-SECTIONAL AREA  
AREA 1.25 mm<sup>2</sup> (48/60 kBTu)  
0.75 mm<sup>2</sup> (18/24/30/36 kBTu)

If the supply cord is damaged, it must be replaced by a special cord or assembly available from the manufacturer of its service agent.



**CAUTION: Make sure that the screws of the terminal fixed tightly.**

## Clamping of cables

- Arrange 2 power cables on the control panel.
- First, fasten the clamp with a screw to the inner boss of control panel.
- For the cooling model, fix the other side of the clamp with a screw strongly.  
For connecting cable to the terminal block, put the 1.0mm<sup>2</sup> cable(thinner cable) on the clamp and tighten it with a plastic clamp to the other boss of the control panel.
- In Australia, the length of power supply cord measured from the entry of the power supply cord to the middle of live pin on the power plug should be over 1.8m.

## Connecting the cable to the Outdoor Unit

- Remove the Cover control from the unit by loosening a screw.  
Connect the wires to the terminals on the control board individually as following.
- Secure the cable onto the control board with the holder (clammer).
- Refix the cover control to the original position with the screw.

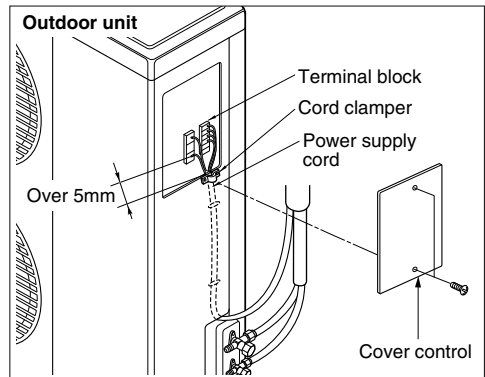

**CAUTION:** After the confirmation of the above conditions, prepare the wiring as follows:

- 1) Never fail to have an individual power specialized for the air conditioner. As for the method of wiring, be guided by the circuit diagram pasted on the inside of control box cover.
- 2) Provide a circuit breaker switch between power source and the unit.
- 3) The screw which fasten the wiring in the casing of electrical fittings are liable to come loose from vibrations to which the unit is subjected during the course of transportation. Check them and make sure that they are all tightly fastened. (If they are loose, it could give rise to burn-out of the wires.)
- 4) Specification of power source
- 5) Confirm that electrical capacity is sufficient.
- 6) Be sure that the starting voltage is maintained at more than 90 percent of the rated voltage marked on the name plate.
- 7) Confirm that the cable thickness is as specified in the power sources specification. (Particularly note the relation between cable length and thickness.)
- 8) Never fail to equip a leakage breaker where it is wet or moist.
- 9) The following troubles would be caused by voltage drop-down.
  - Vibration of a magnetic switch, damage on the contact point there of, fuse breaking, disturbance to the normal function of a overload protection device.
  - Proper starting power is not given to the compressor.

## Form the pipings

- Wrap the connecting portion of indoor unit with the Insulation material and secure it with two Plastic Bands. (for the right pipings)
- If you want to connect an additional drain hose, the end of the drain-outlet should keep distance from the ground. (Do not dip it into water, and fix it on the wall to avoid swinging in the wind.)

### In case of the Outdoor unit being installed below position of the Indoor unit.

- Tape the Pipings, drain hose and connecting Cable from bottom to top.
- Form the pipings gathered by taping along the exterior wall and fix it onto the wall by saddle or equivalent.

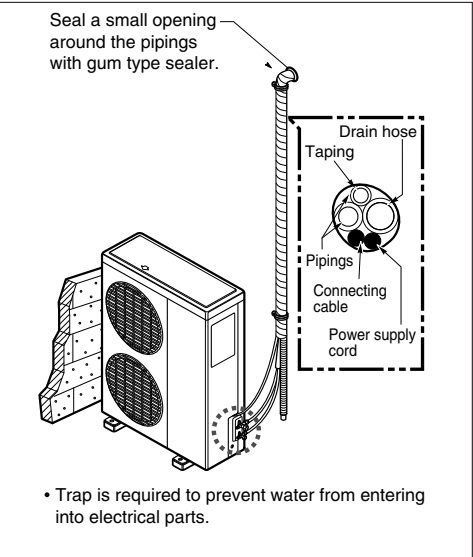

### In case of the Outdoor Unit being installed above position of the Indoor Unit.

- Tape the Pipings and Connecting cable from bottom to top.
- Form the pipings gathered by taping along the exterior wall, and make the trap prevent water from entering into the room.
- Fix the pipings onto the wall by saddle or equivalent.

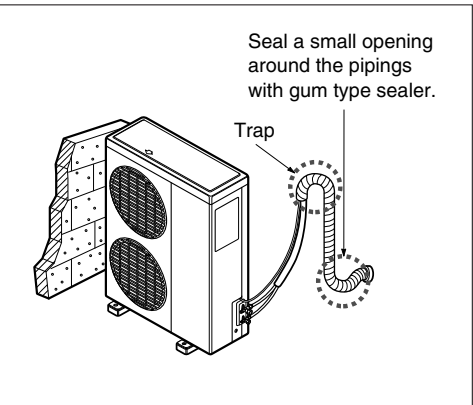

# Air Purging and Evacuation

Air and moisture remaining in the refrigerant system have undesirable effects as indicated below.

1. Pressure in the system rises.
2. Operating current rises.
3. Cooling(or heating) efficiency drops.
4. Moisture in the refrigerant circuit may freeze and block capillary tubing.
5. Water may lead to corrosion of parts in the refrigeration system.

Therefore, the indoor/outdoor unit and connecting tube must be checked for leak tight, and vacuumed to remove incondensable gas and moisture in the system.

## Checking method

### Preparation

- Check that each tube(both liquid and gas side tubes) between the indoor and outdoor units have been properly connected and all wiring for the test run has been completed. Remove the service valve caps from both the gas and the liquid side on the outdoor unit. Check that both the liquid and the gas side service valves on the outdoor unit are kept closed at this stage.

### Leakage test

- Connect the manifold valve(with pressure gauges) and dry nitrogen gas cylinder to this service port with charge hoses.



**CAUTION: Be sure to use a manifold valve for leakage test. If it is not**

**available, use a stop valve for this purpose. The "Hi" knob of the manifold valve must always be kept close.**

- Pressurize the system to no more than 150 P.S.I.G. with dry nitrogen gas and close the cylinder valve when the gauge reading reached 150 P.S.I.G. Next, test for leaks with liquid soap.



**CAUTION: To avoid nitrogen entering the refrigerant system in a liquid state,**

**the top of the cylinder must be higher than its bottom when you pressurize the system. Usually, the cylinder is used in a vertical**

1. Do a leakage test of all joints of the tubing(both indoor and outdoor) and both gas and liquid side service valves. Bubbles indicate a leak. Be sure to wipe off the soap with a clean cloth.
2. After the system is found to be free of leaks, relieve the nitrogen pressure by loosening the charge hose connector at the nitrogen cylinder. When the system pressure is reduced to normal, disconnect the hose from the cylinder.

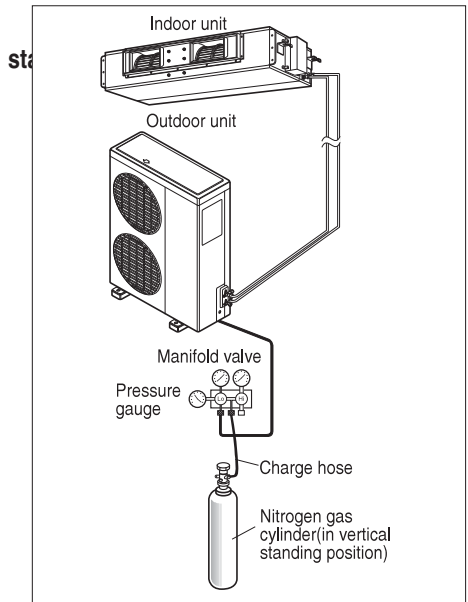

## Soap water method

1. Remove the caps from the 2-way and 3-way valves.
2. Remove the service-port cap from the 3-way valve.
3. To open the 2-way valve turn the valve stem counterclockwise approximately 90°, wait for about 2~3 sec, and close it.
4. Apply a soap water or a liquid neutral detergent on the indoor unit connection or outdoor unit connections by a soft brush to check for

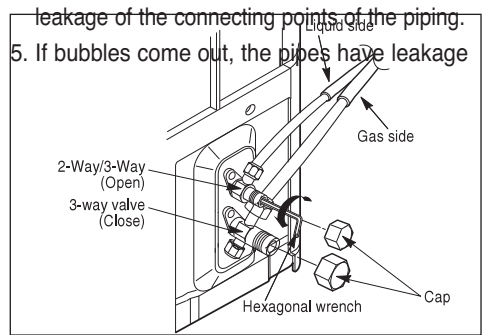

## Evacuation

1. Connect the charge hose end described in the preceding steps to the vacuum pump to evacuate the tubing and indoor unit. Confirm the "Lo" knob of the manifold valve is open. Then, run the vacuum pump. The operation time for evacuation varies with tubing length and capacity of the pump. After the vacuum state is 0.8 torr, continue to vacuumize over 10 minutes more.
2. When the desired vacuum is reached, close the "Lo" knob of the manifold valve and stop the vacuum pump.

## Finishing the job

1. With a service valve wrench, turn the valve stem of liquid side valve counter-clockwise to fully open the valve.
2. Turn the valve stem of gas side valve counter-clockwise to fully open the valve.
3. Loosen the charge hose connected to the gas side service port slightly to release the pressure, then remove the hose.
4. Replace the flare nut and its bonnet on the gas side service port and fasten the flare nut securely with an adjustable wrench. This process is very important to prevent leakage from the system.
5. Replace the valve caps at both gas and liquid side service valves and fasten them tight. This completes air purging with a vacuum pump. The air conditioner is now ready to test run.

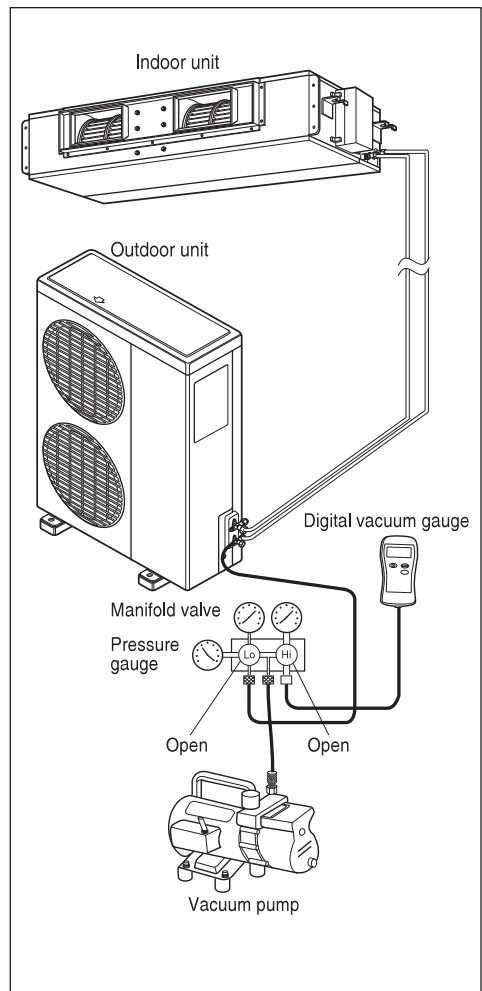







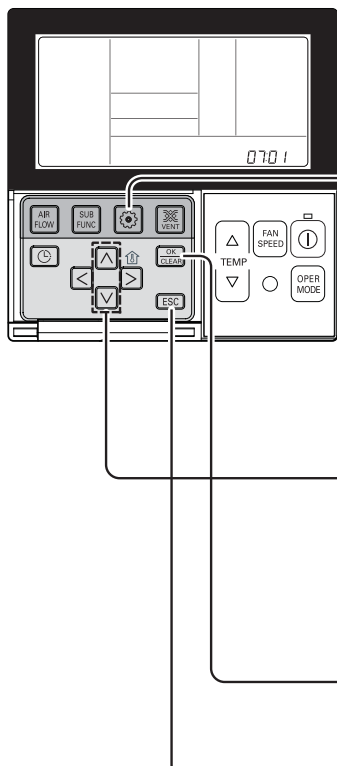

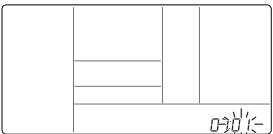

# Group Control

## Installer Setting-Group Setting

It is a function for settings in group control, or 2-remote controller control.



- 1** If pressing  button long for 3 seconds, it enters into remote controller setter setup mode.  
- If pressing once shortly, it enters into user setup mode. Please press more than 3 seconds for sure. 
- 2** If pressing  button repeatedly, it moves to master/slave selection menu as picture below.  

- 3** Select Master/ Slave by pressing   button.  
(00: Slave, 01: Master)  
  
Function Code      Master/Slave value  
 
- 4** Press  button to save. 
- 5** Pressing  button will exit settings mode.  
\* After setup, it automatically gets out of setup mode if there is no button input for 25 seconds.  
\* When exiting without pressing set button, the manipulated value is not reflected.

Remote controller	Function
Master	Indoor unit operates based on master remote controller at group control. (Master is set when delivering from the warehouse.)
Slave	Setup all remote controllers except one master remote controller to slave at group control

\* Refer to the 'group control' part for details

• When controlling in groups, basic operation settings, airflow strength weak/medium/strong, lock setting of the remote controller, time settings, and other functions may be restricted.



# Two Thermistor system

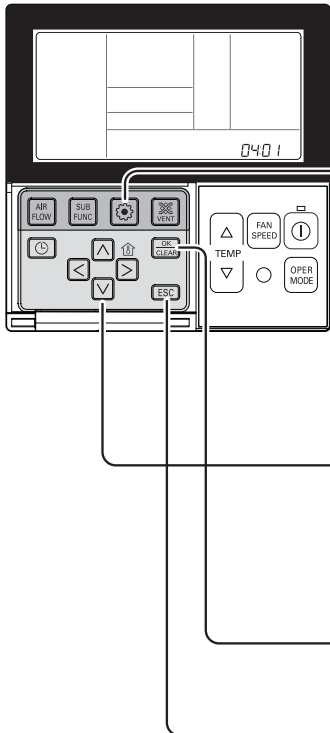

## Installer Setting -Thermistor

This is the function to select the temperature sensor to judge the room temperature.



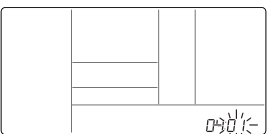

- If pressing  button long for 3 seconds, it enters into remote controller setter setup mode.  
- If pressing once shortly, it enters into user setup mode. Please press more than 3 seconds for sure.





- If moving to room temperature perception sensor selection menu by pressing  button, it indicates as picture below.

- Set Thermistor value by pressing   button. (01: Remote Controller, 02: Indoor, 03: 2TH)



Function Code      Thermistor setting



- Press  button to save.



- Pressing  button will exit settings mode.  
\* After setup, it automatically gets out of setup mode if there is no button input for 25 seconds.  
\* When exiting without pressing set button, the manipulated value is not reflected.

### <Thermistor Table>

Temperature sensor selection		Function
01	Remote controller	Operation in remote controller temperature sensor
02	Indoor unit	Operation in indoor unit temperature sensor
03	2TH	Cooling Operation of higher temperature by comparing indoor unit's and wired remote controller's temperature. (There are products that operate at a lower temperature.)
		Heating Operation of lower temperature by comparing indoor unit's and wired remote controller's temperature.

\* The function of 2TH has different operation characteristics according to the product.

## E.S.P.(External Static Pressure) Setting

### ■ Without Zone System

1. Position V-H, F-H:
  - This position sets the maximum E.S.P as a default set.
2. Position V-L:
  - This position sets the minimum E.S.P as a default set.

### ■ With Zone System

1. Position V-H:
  - Maximum E.S.P setting & Fan speed is varied according to the state of dampers by micom.
2. Position F-H:
  - Maximum E.S.P setting & Fan speed doesn't vary according to the opening & Closing of dampers.
3. Position V-L:
  - Minimum E.S.P setting & Fan speed is varied according to the state of dampers by micom.

\*Maximum: 8 mmAq

Minimum: 18,24,30,36kBtu - 4 mmAq  
48,60kBtu - 6 mmAq



### **CAUTION:**

- Select the position after checking duct work and E.S.P of the unit.
- Manufactured in the position F-H.

This function is applied to only duct type. Setting this in other cases will cause malfunction.

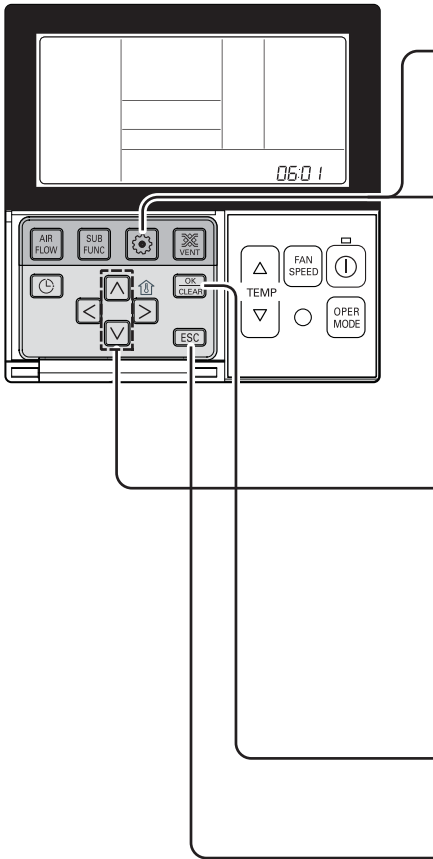

- 1** Press button for 4 seconds to enter the installer setting mode until timer segment displays "01:01".

- 2** If pressing button repeatedly, it moves to static pressure selection menu as picture below.

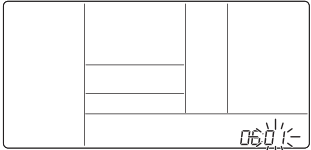
- 3** Select static pressure by pressing button.  
(01:V-H, 02:F-H, 03:V-L, 04:F-L)

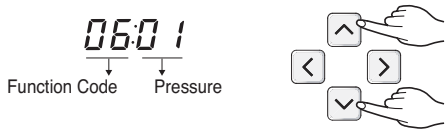
- 4** Press button to save.

- 5** Pressing button will exit settings mode.  
\* After setup, it automatically gets out of setup mode if there is no button input for 25 seconds.  
\* When exiting without pressing set button, the manipulated value is not reflected.

ENGLISH

<Static Pressure Setting Table>

Pressure selection		Function	
		Zone state	ESP standard value
01	V-H	Variable	High
02	F-H	Fixed	High
03	V-L	Variable	Low
04	F-L	Fixed	Low

# How to Set E.S.P?

## Installer Setting -E.S.P.

This is the function that decides the strength of the wind for each wind level and because this function is to make the installation easier.

- If you set ESP incorrectly, the air conditioner may malfunction.
- This setting must be carried out by a certificated-technician.

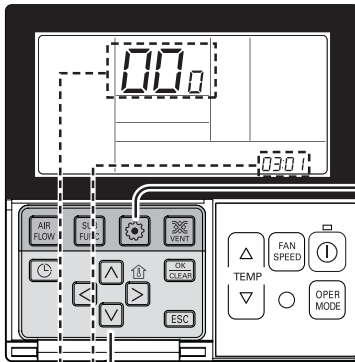

Function code,  
ESP code

ESP value

**1** If pressing button long for 3 seconds, it enters into remote controller setter setup mode.  
- If pressing once shortly, it enters into user setup mode. Please press more than 3 seconds for sure.



**2** If entering into ESP setup mode by using button, it indicates as the picture below.

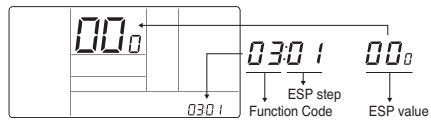

**3** Select ESP fan step by pressing button. (01: very low, 02: low, 03: medium, 04: high, 05: power)

0301

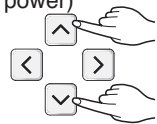

**4** Move to ESP value setting by pressing button.  
(It is 000 when delivering from the warehouse.)

0301 000

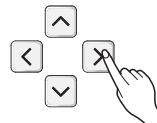

**5** Press button to setup ESP value.

(It is possible to setup ESP value from 1 to 255, and 1 is the smallest and 255 is the biggest.)

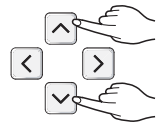

- When setting ESP value on the product without very weak wind or power wind function, it may not work.

# External Static Pressure & air Flow

Table 1.

Static Pressure(mmAq)		4	6	8 (Default)	10
Model	Step(Hi/Med/Lo)	Setting Value			
	CMM				
18 kBtu/h	16.5	165	155	140	-
	14.5	180	175	160	-
	13	195	185	175	-
24 kBtu/h	20	115	100	1	-
	18	140	130	120	-
	16	155	155	145	-
30 kBtu/h	28	90	90	85	-
	24	120	120	115	-
	20	140	140	140	-
36 kBtu/h	32	70	50	1	-
	28	108	108	105	-
	24	130	130	125	-
48 kBtu/h	45	-	175	110	1
	40	-	195	175	150
	35	-	210	200	195
60 kBtu/h	50	-	100	1	1
	45	-	175	110	1
	40	-	195	175	150

- NOTICE** : 1. Be sure to set the value referring table 1. Unexpected set value will cause mal-function.
2. Table 1 is based at 220V. According to the fluctuation of voltage, air flow rate varies.
3. Duct work must be designed within the range of   on installing the unit.
4. If duct work is designed under   External Static Pressure, adjust the External Static Pressure applying air damper.

# Test Running

## Installer Setting -Test Run Mode

After installing the product, you must run a Test Run mode.

For details related to this operation, refer to the product manual.

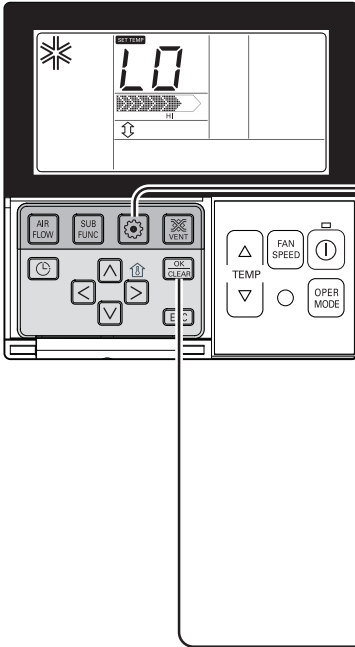

**1** If pressing  button long for 3 seconds, it enters into remote controller setter setup mode.

- If pressing once shortly, it enters into user setup mode. Please press more than 3 seconds for sure.
- Please cancel the right and left of wind direction for RAC product.

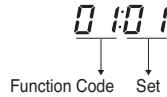

**2** Setup figure '01' blinks at the lower part of indication window.

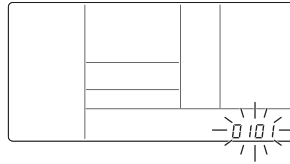

**3** Press  button to start.

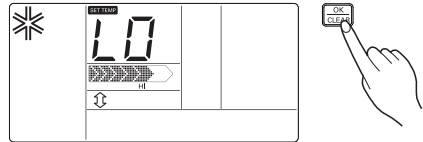

**4** During the test run, pressing the below button will exit the test run.

- Select operation, temperature up/down, wind flow control, wind direction, start/stop button.

## Evaluation of the performance

Operate unit for 15~20 minutes, then check the system refrigerant charge:

1. Measure the pressure of the gas side service valve.
2. Measure the temperature of the intake and discharge of air.
3. Ensure the difference between the intake temperature and the discharge is more than 8°C
4. For reference, the gas side pressure of optimum condition is as below.(Cooling)

Refrigerant	Outside ambient TEMP.	The pressure of the gas side service valve.
R 22	35°C (95°F)	4~5 kg/cm <sup>2</sup> G(56.8~71.0 P.S.I.G.)
R 410A	35°C (95°F)	8.5~9.5 kg/cm <sup>2</sup> G(120~135 P.S.I.G.)

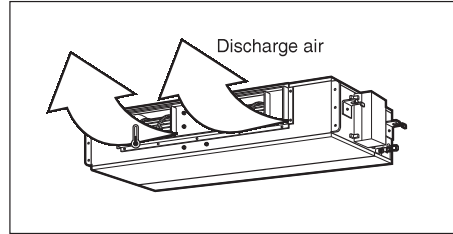

**NOTICE** : If the actual pressure are higher than shown, the system is most likely over-charged, and charge should be removed. If the actual pressure are lower than shown, the system is most likely undercharged, and charge should be added.  
The air conditioner is now ready for use.

# Accessory Installation Guide

## Dry Contact(Only AC 24V, DC 5V&12V)

- Fix dry contact on the indoor control box cover.
- Connect dry contact(CN-CC) to Indoor PCB(CN-CC) with cable provided.
- Refer to dry contact installation manual for detailed installation method.

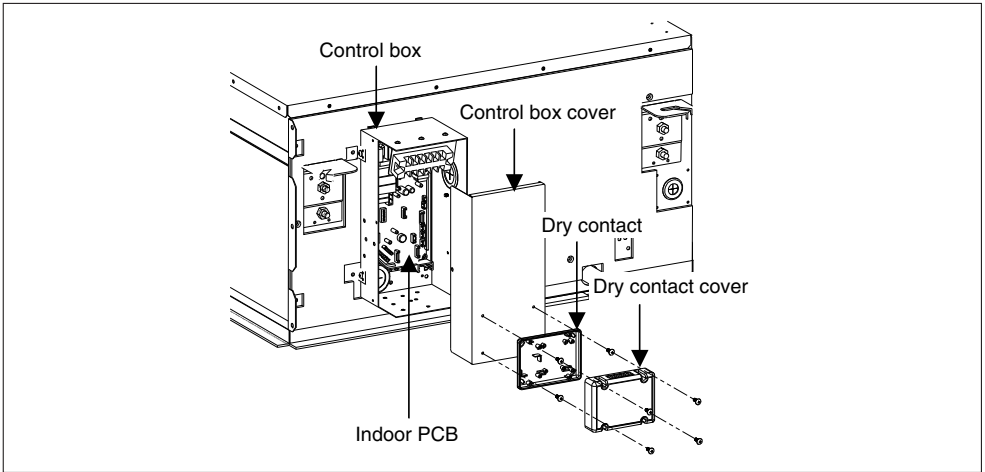

## Installer Setting-Dry Contact Mode Setting

Dry contact function is the function that is possible to use only when dry contact equipment is separately purchased/setup.

- If pressing button long for 3 seconds, it enters into remote controller setter setup mode.  
- If pressing once shortly, it enters into user setup mode. Please press more than 3 seconds for sure.
- If pressing button repeatedly, it moves to remote controller dry contact mode setup menu as picture below.
- Select Dry contact setting by pressing button.  
(00 : Automatic, 01 : manual)
- Press button to save.
- Pressing button will exit settings mode.  
\* After setup, it automatically gets out of setup mode if there is no button input for 25 seconds.  
\* When exiting without pressing set button, the manipulated value is not reflected.

### ► What is Dry Contact?

Like hotel card key and body perception sensor, it is the signal of the point of contact when using air-conditioner by interlocking.

- Please refer to dry contact manual for more details.

## Remote Temperature Sensor

- After deciding where the remote temperature sensor is installed, decide the location and height of the fixing screws. (Interval between the screws : 60mm).
- After removing the control box cover of the indoor unit, remove the room temperature sensor in **CN-ROOM** of the main PCB.
- Insert the connector of remote sensor wire into **CN-ROOM**.
- Using the DC line hole when connecting the wire to indoor PCB.
- For using the two thermistor function, the remote sensor should be installed from the wired remote controller as far as possible.
- Refer to damper remote sensor manual for detailed installation method.

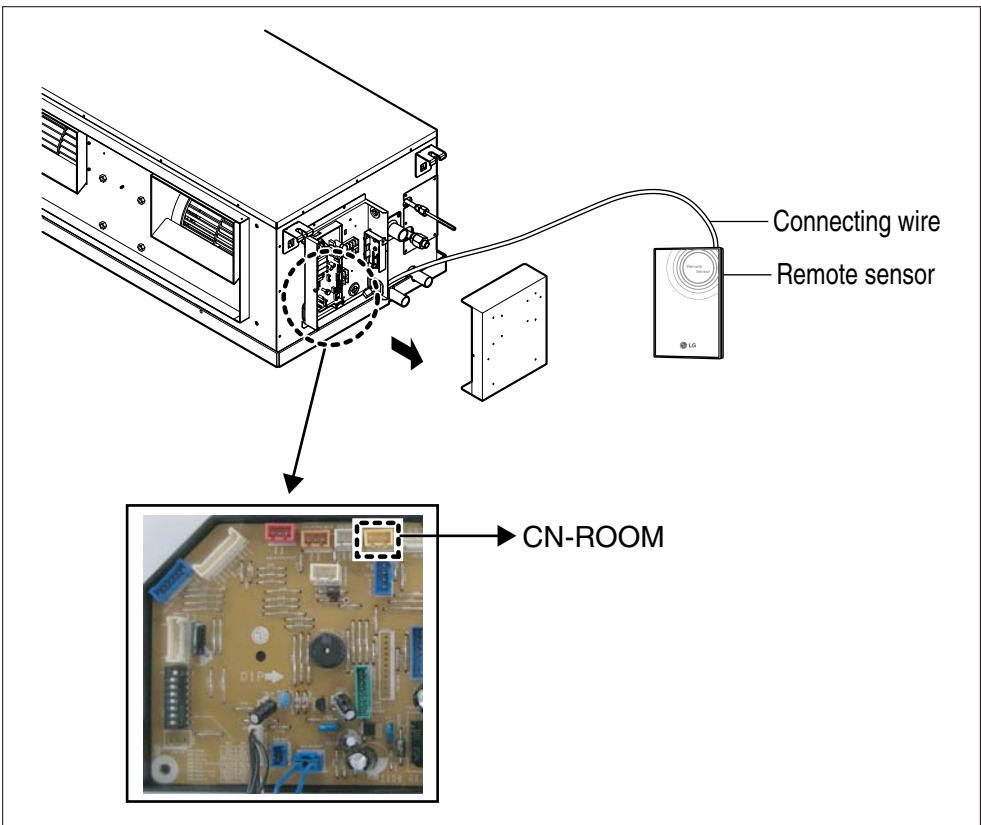
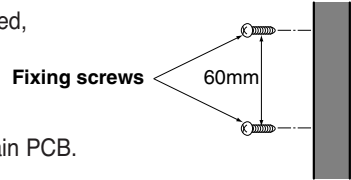

## PI 485

- Fix the PI485 to the indoor control box.
- Connect the PI485 (CN\_COMM) to the PCB(CN\_CC) using the provided cable.
- Connect the PI485 (BUS-A,BUS-B) to other network products
  - Use the DC line hole.
- Tie the cables with the tie-wraps and clamps after installing PI485.
- Refer to the PI485 installation manual for detailed installation method.

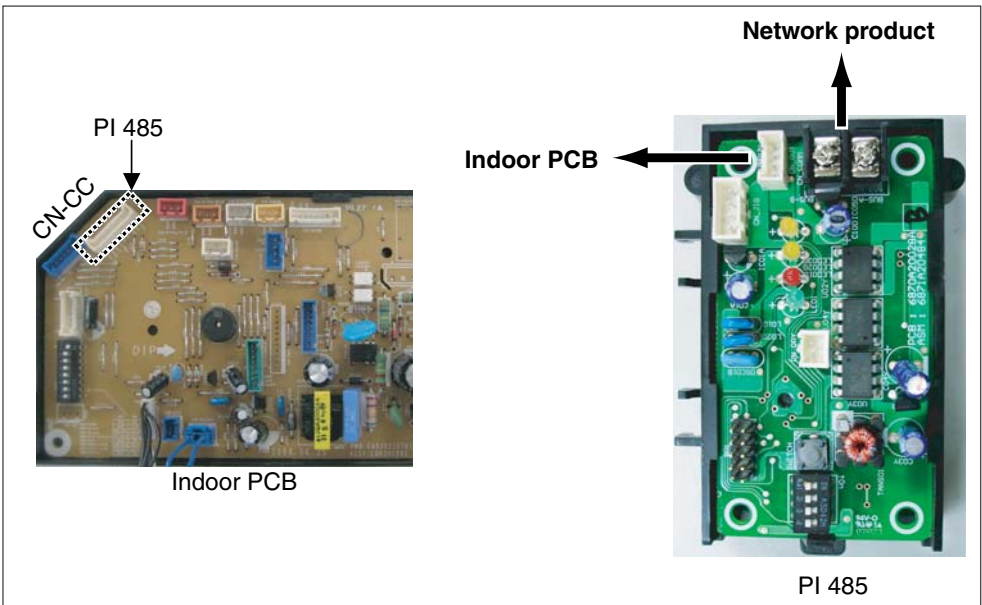
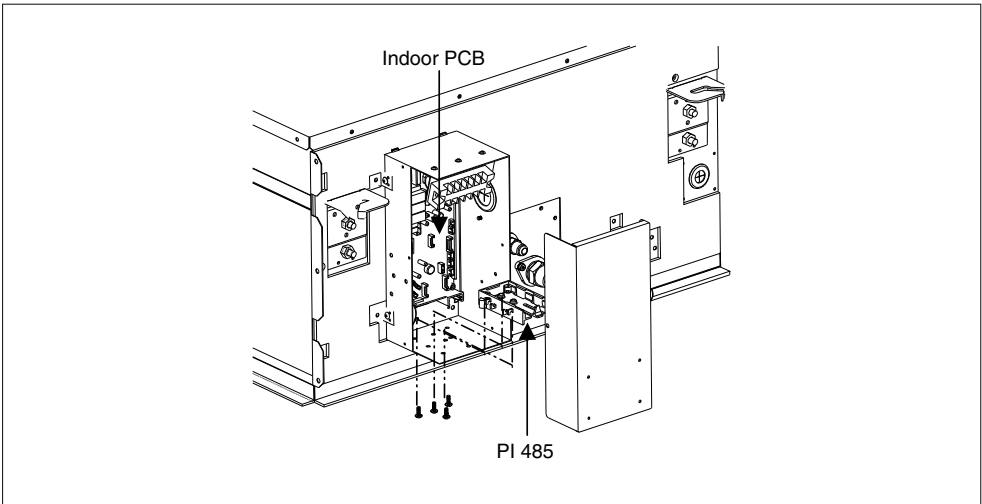

# Installation guide at the seaside

## ⚠ CAUTION

1. Air conditioners should not be installed in areas where corrosive gases, such as acid or alkaline gas, are produced.
2. Do not install the product where it could be exposed to sea wind (salty wind) directly. It can result corrosion on the product. Corrosion, particularly on the condenser and evaporator fins, could cause product malfunction or inefficient performance.
3. If outdoor unit is installed close to the seaside, it should avoid direct exposure to the sea wind. Otherwise it needs additional anticorrosion treatment on the heat exchanger.

## Selecting the location(Outdoor Unit)

- 1) If the outdoor unit is to be installed close to the seaside, direct exposure to the sea wind should be avoided. Install the outdoor unit on the opposite side of the sea wind direction.

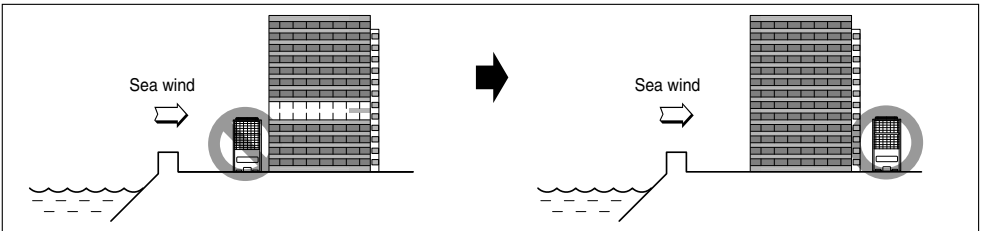

- 2) In case, to install the outdoor unit on the seaside, set up a windbreak not to be exposed to the sea wind.

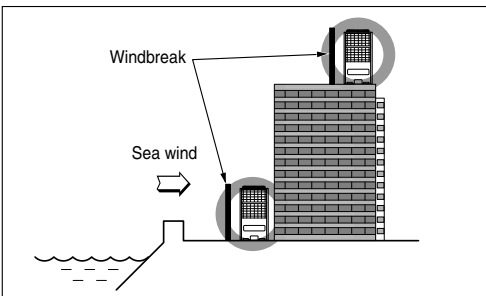

- It should be strong enough like concrete to prevent the sea wind from the sea.
- The height and width should be more than 150% of the outdoor unit.
- It should be keep more than 70 cm of space between outdoor unit and the windbreak for easy air flow.

- 3) Select a well-drained place.

1. If you can't meet above guide line in the seaside installation, please contact LG Electronics for the additional anticorrosion treatment.
2. Periodic ( more than once/year ) cleaning of the dust or salt particles stuck on the heat exchanger by using water

