



COMPACT DISC STEREO MUSIC SYSTEM

Owner's Manual

**MODELS : FFH-217A/L/S/AX
FE-217E**

Please read this manual carefully before
operating your set.
Retain it for future reference.

Designs and specifications are
subject to change without
notice for improvement.



CE (for CE Region)

P/NO.:3828SXD010E

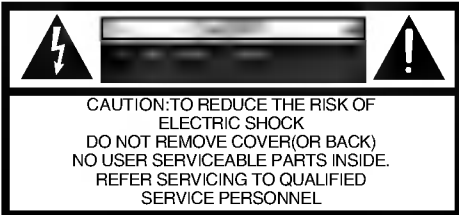

Explanation Graphical Symbols:



The lightning flash with arrowhead symbol, within an equilateral triangle is intended to alert the user to the presence of uninsulated dangerous voltage within the product's enclosure that may be of sufficient magnitude to constitute a risk of electric shock to persons.



The exclamation point within an equilateral triangle is intended to alert the user to the presence of important operating and maintenance (servicing) instructions in the literature accompanying the appliance.

WARNING:

TO REDUCE THE RISK OF FIRE OF ELECTRIC SHOCK, DO NOT EXPOSE THIS APPLIANCE TO RAIN OR MOISTURE. To avoid electrical shock, do not open the cabinet, Refer servicing to qualified personnel only.

CAUTION

Use of controls or adjustments or performance of procedures other than those specified herein may result in hazardous radiation exposure.

(FOR THE CUSTOMERS IN EUROPE)

If this product is marked with the CE-symbol, it means which is conformed to EMC regulation 89/336/EEC.

Laser component in this product is capable of emitting radiation exceeding the limit for Class 1.

CAUTION: INVISIBLE LASER RADIATION WHEN OPEN AND INTERLOCKS DEFEATED. AVOID EXPOSURE TO BEAM.

WARNING: OSYNLIG LASERSTRÅLNING NÄR DENNA DEL ÄR ÖPPNAD STRÅLEN ÄR FARLIG.

Attention: Quand l'appareil est ouvert, ne pas s'exposer aux radiations invisibles du faisceau laser.

This label is located on the interior.

CLASS 1 LASER PRODUCT
 KLASSE 1 LASER PRODUKT
 LUOKAN 1 LASER LAITE
 KLASSE 1 LASER APPARAT
 CLASSE 1 PRODUIT LASER

This Compact Disc player is classified as a CLASS 1 LASER product.

The CLASS 1 LASER PRODUCT label is located on the exterior.

(FOR CUSTOMERS IN CANADA)

CAUTION:

TO PREVENT ELECTRIC SHOCK, DO NOT USE THIS (POLARIZED) PLUG WITH AN EXTENSION CORD, RECEPTACLE, OR OTHER OUTLET UNLESS THE BLADES CAN BE PULLY INSERTED TO PREVENT BLADE EXPOSURE.

This class B digital apparatus meets all requirements of the canadian Interference-Causing Equipment Regulations.

WARNING:

SHOCK HAZARD - DO NOT OPEN

MISE EN GARDE:

Pour éviter les chocs électriques, n'utilisez pas cette fiche (polarisée) avec une rallonge, un réceptacle ou une autre prise si vous ne pouvez pas y insérer les brouches à fond.

MISE EN GARDE

Cet appareil numérique de la classe B respecte toutes les exigences de Règlement sur le matériel brouilleur de Canada.

AVERTISSEMENT

RISQUE DE CHOC ELECTRIQUE-NE PAS OUVRIR (FOR CUSTOMERS IN THE UNITED STATES OF AMERICA)

Note to CATV system installer:

This reminder is provided to call the CATV system installer's attention to Article 820-40 of the NEC that provides guidelines for proper grounding and, in particular, specifies that the cable ground shall be connected to the grounding system of the building, as close to the point of cable entry as practical.

NOTE:

The interference potential to the device.

This equipment generates and uses radio frequency energy and if not installed and used properly, that is in strict accordance with the manufacturer's instructions, may cause interference to radio and television reception. It has been type tested and found to comply with the limits for a Class B computing device in accordance with the specifications in subparts J of Part 15 of FCC Rules, which are designed to provide reasonable protection against such interference in a residential installation. However, there is no guarantee that interference will not occur in a particular installation. If this equipment does cause interference to radio or television reception, which can be determined by turning the equipment off and on, the user is encouraged to try to correct the interference by one of more of the following measures:

- Reorient or relocate the receiving antenna.
- Increase the separation between the equipment and receiver.
- Connect the equipment into an outlet on a circuit different from that to which the receiver is connected.
- Consult the dealer or an experienced radio/TV technician for help.

(FOR CUSTOMERS IN THE UNITED KINGDOM)

WIRING INSTRUCTIONS

This appliance is supplied with a BS1363 approved 3 amp fused mains plug. When replacing the fuse always use a 3 amp BS1362 approved type. Never use this plug with the fuse cover omitted. To obtain a replacement fuse cover contact your supplying dealer or "LG ELECTRONICS U.K.LTD"

If the mains sockets in your home differ, or are not suitable for the type of plug supplied, then the plug should be removed and a suitable type fitted. Please refer to the wiring instructions below:

Warning: The mains plug severed from the mains lead of this appliance must be destroyed. A mains plug with bared wires is hazardous if engaged in a mains output line socket.

IMPORTANT

The wires in this mains lead are coloured in accordance with the following codes:

Blue : Neutral
 Brown : Live

As the colour of the wires in the mains lead of this appliance may not correspond with the coloured markings identifying the terminals in your plug, proceed as follows:

The wire which is coloured blue must be connected to the terminal which is marked with the letter N or coloured black.

The wire which is coloured brown must be connected to the terminal which is marked with the letter L or coloured red.

If a 13 amp BS1363 plug or any other type of plug is used, 3 amp BS1362 approved fuse must be fitted either in the plug or at the distribution board.

Warning: Do not connect either wire to the earth pin, marked with the letter E or with the earth symbol  or coloured green or green and yellow.

CONTROL LOCATIONS

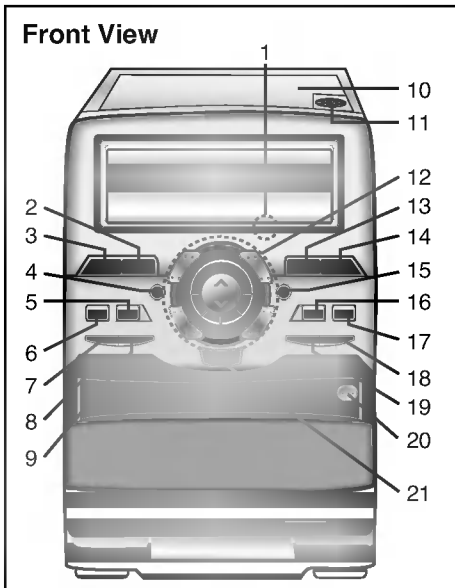

Front View

1. REMOTE SENSOR LENS
2. TIMER BUTTON
3. CLOCK BUTTON
4. = RECORD/RECORD PAUSE BUTTON(TAPE)
5. MEMORY(TUNER)/PROGRAM(CD) BUTTON
6. POWER/STAND BY BUTTON
7. PLAY MODE() BUTTON (TAPE)
8. HEADPHONE SOCKET() (3.5mm)
9. UBB (Ultra Bass Booster) BUTTON
10. CD DOOR
11. CD DOOR EJECT BUTTON
12. = TUNING /TIME DOWN/UP BUTTONS (RADIO/CLOCK)
 SKIP/SEARCH BUTTONS(CD)
 REWIND/FAST FORWARD BUTTONS (TAPE)
 =TAPE PLAY DIRECTION BUTTONS
 PRESET DOWN/UP BUTTONS(RADIO)
 CD PLAY BUTTON()
 VOLUME UP/DOWN () BUTTONS
13. TUNER/BAND BUTTON
14. FUNCTION SELECTION BUTTON (TUNER/CD/TAPE/AUX)
15. =STOP/CLEAR BUTTON(CD)
 STOP BUTTON(TAPE)
16. TAPE COUNTER RESET, SET(CLOCK/TIMER), CD (CD PAUSE) BUTTON

17. FM MODE/RIF(Radio Inerference Filter) BUTTON
 CD SYNCHRO RECORDING BUTTON
18. EQ. PATTERN BUTTON
19. DEMONSTRATION BUTTON
 DISPLAY MODE BUTTON
20. DECK EJECT POSITION ()
21. HI-TONE BUTTON

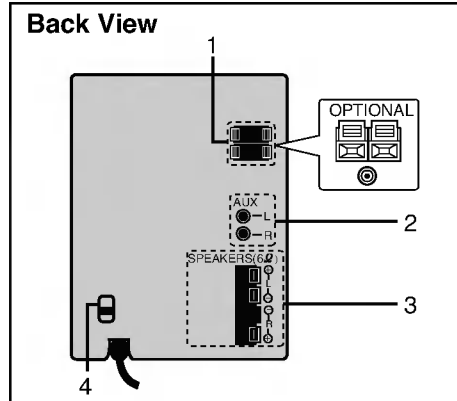

Back View

1. ANTENNA(AERIAL) CONNECTION TERMINALS
2. AUXILIARY INPUT SOCKETS
 Connect the audio output RCA (phono) type left/right plugs from your stereo TV or VCR or another Tape deck to the AUX sockets on the back of the unit.
3. SPEAKER CONNECTION TERMINALS
4. VOLTAGE SELECTOR (OPTIONAL)

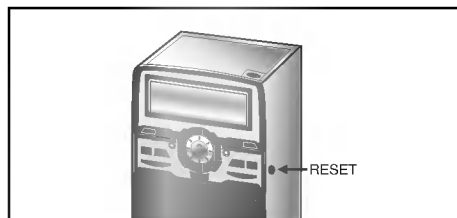

RESET BUTTON

Don't press this button if possible except when using this unit for the first time or if there is a malfunction.

If pressed, it is necessary to unplug the power cord and press the button for more than 5 secs. Plug in the power cord. If the RESET button is pressed by mistake, all previously memorized information will be erased.

DISPLAY

Display

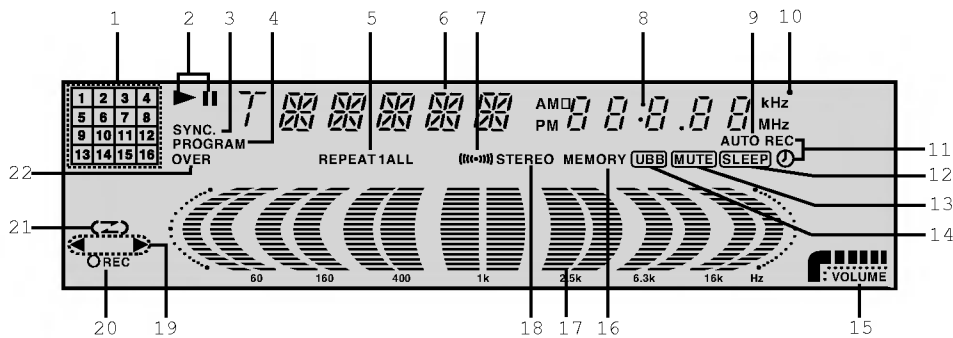

- | | |
|---|--|
| 1 CD MUSIC CALENDAR | 12 SLEEP indicator |
| 2 CD PLAY/PAUSE indicator | 13 MUTE indicator |
| 3 CD SYNCHRO RECORDING indicator | 14 UBB indicator |
| 4 CD PROGRAM indicator | 15 VOLUME LEVEL indicator |
| 5 CD REPEAT indicator | 16 MEMORY indicator |
| 6 FUNCTION, EQ PATTERN display | 17 LEVEL indicator of each frequency |
| 7 FM STEREO RECEIVING indicator | 18 FM STEREO indicator |
| 8 CLOCK, TAPE COUNTER, CD PLAYING TIME, FREQUENCY display | 19 TAPE DIRECTION/TAPE ENTERED indicator |
| 9 AUTO TUNING indicator | 20 RECORD/RECORD PAUSE indicator |
| 10 RIF(Radio Interference Filter)indicator | 21 PLAY MODE indicator |
| 11 TIMER indicator | 22 CD MUSIC CALENDAR OVER indicator |

AUTO FUNCTION SELECT SYSTEM

This stereo system has an auto function select system for various functions.

i. e. If a function is in operation (e. g. radio reception), and you wish to switch to another (e.g. cassette playback), all you have to do is select the desired function (cassette playback) directly, the unit automatically switches to the new function(cassette recorder).

This applies for the following functions:

1. On the remote control

Cassette : PLAY button (◀ or ▶)

CD : PLAY/ PAUSE button (▶ ||)

RADIO : PRESET UP(^)/DOWN(v) buttons, BAND button

2. On the unit

RADIO : BAND button

REMOTE CONTROL

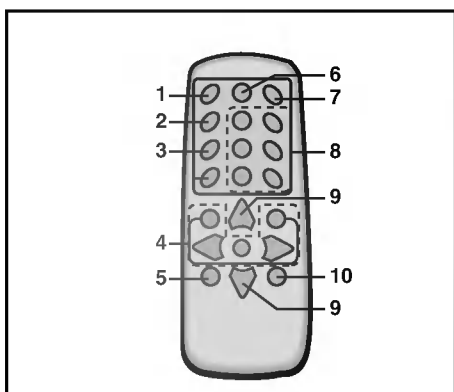

1. POWER button
2. BAND(TUNER) button
3. PRESET UP(^)/DOWN(v) buttons
4. CD FUNCTION buttons
 REPEAT button
 PLAY/II (PAUSE) button
 ◀◀◀/▶▶▶ (SKIP/SEARCH buttons)
 ■ = STOP/CLEAR button
5. EQ. pattern button
6. AUX button
7. SLEEP button
8. DECK FUNCTION buttons
 ▶/◀ = PLAY DIRECTION buttons
 ▶▶/◀◀ = Fast Forward/Rewind buttons
 ■ = STOP button
 ●/II = RECORD/RECORD PAUSE button
9. VOLUME UP(+)/DOWN(-) buttons
10. MUTE button

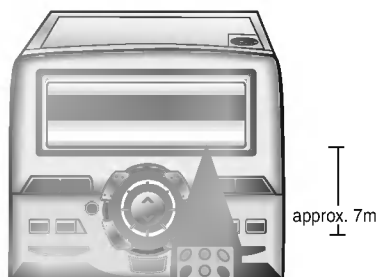

Range

The remote control device is designed for the range shown in the illustration opposite.

NOTE:

Strong light or obstacles between the remote control device and the stereo system may interfere with the functioning of the remote control.

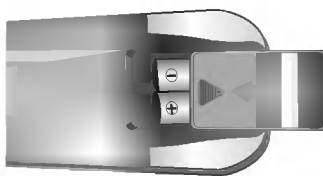

Notes on Batteries

- Your remote control comes with batteries.
- Use two "AAA(UM-4, IEC R03)" type high quality batteries.
- When the remote control fails to operate accurately at maximum distance from the unit, Replace the worn out batteries with new ones.
- Install two "AAA" type batteries, observing correct battery polarity (⊕ and ⊖)
- Do not use different types of batteries together, or the old ones with new ones.
- When you are not going to use the unit for a long time, remove the batteries to prevent possible electrolyte leakage.

CONNECTING THE SPEAKERS

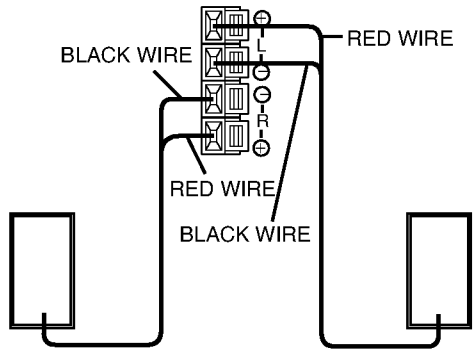

ANTENNA CONNECTIONS

● OPTION (2 BAND (AM/FM) AREA)

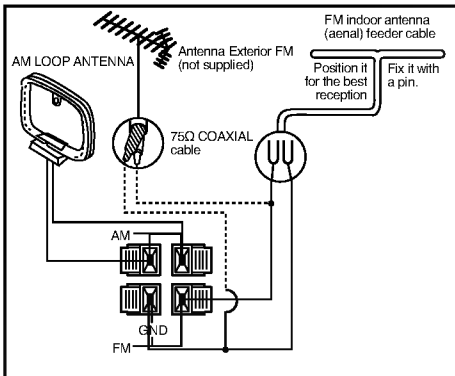

● OPTION (2 BAND (FM/AM) AREA)

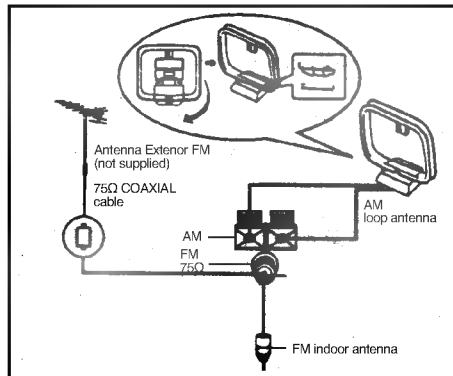

● OPTION (3 BAND (FM/MW/LW) AREA)

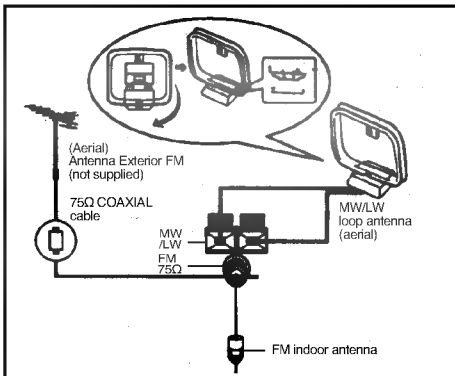

● OPTION (3 BAND (FM/MW/SW) AREA)

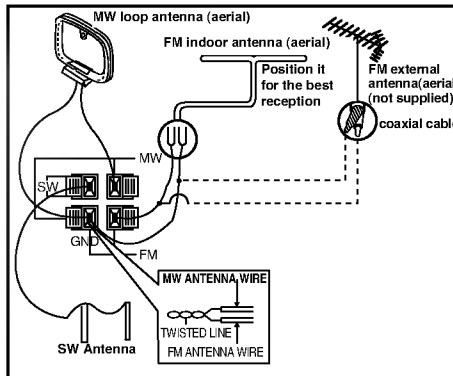

SETTING THE CLOCK

1. Press the CLOCK button. (If the clock is already set, press and hold the CLOCK button for more than 2 seconds.) - The hours begin to blink
2. Select a 24 hour cycle or 12 hour cycle by using the TUNING/TIME DOWN/UP buttons.
5. Press the SET/CNT RESET/CD PAUSE button.
6. Use the TUNING/TIME DOWN/UP buttons to set the correct minutes.
7. Press the SET/CNT RESET/CD PAUSE and the correct time is shown on the display.
8. Press the CLOCK button at any time to display the time for about 3 seconds.

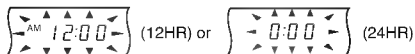

3. Press the SET/CNT RESET/CD PAUSE button to confirm the selected hour cycle.
4. Use the TUNING/TIME DOWN/UP buttons to set the correct hours.

NOTES

- DIMMER FUNCTION
In power off mode, the display will be darkened by half.

AUDIO ADJUSTMENT

■ Volume Adjustment

Press VOLUME ▲ button to increase the sound level, or press VOLUME ▼ button to decrease it. (Or press VOL. UP(+) or VOL. DOWN(-) on the remote control)

■ Sound Quality Adjustment

▶ To reinforce bass

Press UBB repeatedly so that the 'UBB-1' or 'UBB-2' is scrolled on the display. To cancel it, press the button so that 'UBB OFF' is scrolled.

▶ To reinforce treble

Press Hi-TONE.

▶ To activate stereo sound

You can choose between 6 fixed sound impressions: select a desired sound mode by using the EQ. PATTERN button.

- FLAT : linear frequency response
- ROCK : more bass, more treble
- POP : less bass, less treble
- CLASSIC: for orchestral music
- VOCAL : put an emphasis on the vocal sound.
- JAZZ : feel like a jazz club. It effectively creates the flavor of harmony and mood.

▶ Headphone Socket.

Connect a stereo headphones plug(3.5mm) to the headphone socket.

The speakers are automatically disconnected when you plug in the headphones (not supplied).

■ MUTE button(on remote control)

Press this button to mute your unit. You can mute your unit in order, for example, to answer the telephone. the **MUTE** indicator appears on the display.

■ DISPLAY MODE button(In power-on state)

Whenever you press the DISPLAY MODE button, you can enjoy the spectrum change with 9 types in the display.

■ DEMO button(In power-off state)

Press this button in power off to demonstrate for the functions TUNER, TAPE, AUX and CD in the display. To cancel it, press the button again.

AUXILIARY FUNCTION

1. Switch on the auxiliary device i.e. TV or VCR, connected to the rear mounted AUX phono sockets.
2. Press the "AUX" function button.

Note:

you can also record from the auxiliary input source, see Cassette Deck Function Section.

TUNER FUNCTIONS

To listen to the Radio

1. Press the BAND(TUNER/BAND) button to select a desired waveband. (AM or FM/FM, MW or LW)
2. ① To tune to the desired station with automatic tuning, keep TUNING/TIME DOWN/UP button depressed for more than 1 second.
② To tune to the desired station with manual tuning, press the TUNING/TIME DOWN/UP button within 1 second repeatedly.
3. When listening to FM stations press the MODE/RIF button for FM stereo reception. STEREO will appear in the display. When a weak FM station is being received-press the MODE/RIF button so that STEREO is cleared from the display.

NOTE:

MODE/RIF (Radio Interference Filter) button

Use this button to switch to mono reception if stereo reception is distorted by noise. When recording the MW(AM) or LW broadcast, beat noises occur. If it does, press this button once.

Presetting the stations

1. To clear any programme previously stored in any memory.

- ① Press the MEMORY/PROG. button more than 2 seconds in TUNER mode so that CLEAR is blinked in the display.
- ② Press the MEMORY/PROG. button while CLEAR is blinked in the display.

TUNER FUNCTIONS

2. To memorize the stations in order

- ① Press the BAND(TUNER/BAND) button to select a desired waveband.
- ② Press the TUNING/TIME DOWN/UP button to select a desired station.
- ③ Press the MEMORY/PROG. button. MEMORY appears and preset number blinks.
- ④ Press the MEMORY/PROG. button again while preset number is blinked.
- ⑤ Repeat step ① to ② to be memorized up to 30 stations.

3. To memorize in selection channel number.

- ① Select a desired station.
- ② Press the MEMORY/PROG. button

- ③ Select a desired channel number by pressing the PRESET (◀/ ▶) button while the preset number is blinked..
- ④ Press the MEMORY/PROG. button again before stop the channel number blinking.

4. To memorize in adding channel number.

- ① Select a desired station.
- ② Press the MEMORY/PROG. button
- ③ Press the MEMORY/PROG. button again while the channel number is blinked..

5. To recall presets

Press and hold the PRESET (◀/ ▶) button until the desired preset number appears or press it repeatedly.

CD FUNCTIONS

To play a CD

1. Press the FUNCTION button repeatedly so that 'CD' is appeared on the display.

- If no disc is entered in the disc drawer, the DISC indicator is displayed.

2. Load a disc by using the CD DOOR EJECT ▲ button.

3. To start play back

- Press the CD PLAY (▶) button on the system or PLAY/II (▶||) button on the remote control.

4. To pause the play

- Press the SET/CNT RESET/CD PAUSE button on the system or PLAY/II (▶||) button on the remote control.

5. To resume the play

- Press the CD PLAY (▶) button, SET/CNT RESET/CD PAUSE button on the system or PLAY/II (▶||) button on the remote control.

6. To stop playback

- Press the STOP/CLEAR (■) button.

7. To specify a track to play

- Press the ◀◀(◀◀) or ▶▶(▶▶) button repeatedly during stop or play until your desired track number appears-play will start from that track number.

8. To play a desired location on CD.

- Hold down the ◀◀or▶▶ button during play or pause.
- When the button is held down, there will be continuous change (of position on the CD).

9. To repeat play

- Press the REPEAT button on the remote control.
- Once, one track will repeat(REPEAT 1).
- Two times, all tracks will repeat(REPEAT ALL).
- Three times, repeat mode is cancelled

10. Programme play (this cannot be set during playback).

- A maximum of 20 tracks can be programmed.
 - ① Press the MEMORY/PROG. button.
 - ② Specify a track to play with the ◀◀(◀◀) or ▶▶(▶▶) button
 - ③ Press the MEMORY/PROG. button to store this track.
 - ④ Repeat step ② to ③ . The programmed tracks will be displayed on the music calendar. The programmed tracks will be played repeatedly.
 - ⑤ Press the CD PLAY (▶) button to play the tracks.

⑥ To check a programme sequence.

During programmed play press the STOP/CLEAR (■) button, and then press the MEMORY/PROG. button repeatedly.

⑦ To change an existing programme.

- a) During stop the programmed play press the MEMORY/PROG. button until the desired program position appears in the display.
- b) Select a new track using the ◀◀(◀◀) or ▶▶(▶▶) button.
- c) Press the MEMORY/PROG. button to put the new track in position.

⑧ To add a programme

If less than 20 programme positions are in memory, additional tracks may be added by following this procedure.

- a) During stop the programmed play press the MEMORY/PROG. button until "00" appears in the track number position on the display. While the track number "00" is blinked if you press the MEMORY/PROG. button again, it is changed to the CD normal play mode.
- b) Select the track to be added by using the ◀◀(◀◀) or ▶▶(▶▶)button.
- c) Press the MEMORY/PROG. button two times.
- d) Repeat step b) to c)
- e) After the last(20th) track has been entered, press the MEMORY/PROG. button once only.

⑨ To erase a programme sequence

- In the stop mode press the MEMORY/PROG. button, and then press the STOP/CLEAR (■) button.
- In the programmed play press the STOP/CLEAR (■) button two times.
- It is also erased if the CD drawer is opened

⑩ If you press the STOP/CLEAR (■) button during programmed play, the PROGRAM indicator goes out in the display and the programmed playback is cancelled.

At that time, if you wish to resume the programmed playback press the MEMORY/PROG. button and press the CD PLAY(▶) button.

CASSETTE DECK FUNCTION

1. Tape play

- ① Press the FUNCTION button to enter the tape mode so that 'TAPE' is appeared on the display.
- ② Press the EJECT ▲ position to open the cassette door.
- ③ Insert a recorded cassette with the exposed tape side down.
- ④ Press the ► (forward) or ◀ (backward) button to begin tape playback.
- ⑤ To manually change the tape play direction press the opposite PLAY button from the direction the tape is currently playing.
- ⑥ To stop play at any time press the STOP /CLEAR (■) button.

2. To select a play mode (reverse mode)

Press the PLAY MODE(TAPE) button during tape function or recording from another function.

- = forward or backward play once only
- ◀ = forward and backward play once only
- ◀➤ = forward and backward play for six times.

3. Tape counter reset function.

During tape stop or play press the SET/CNT RESET/ CD PAUSE button.

4. Recording from Radio, CD or auxiliary source.

NOTE : Use only normal tapes.

- ① Insert a blank tape into deck.
- ② Set to tape function by pressing the FUNCTION button. (And press the SET/CNT RESET/ CD PAUSE button to reset the tape counter)
- ③ Select a play mode by pressing the PLAY MODE (TAPE) button.
 - If you want to record forward(►) or backward(◀) only set to ➤ .

- If you want to record from forward(►) to backward(◀) set to ➤◀ or ➤◀➤ .

- ④ Select a function that you want to record and play it.
- ⑤ Press the ●/|| (REC/PAUSE) button again. " ● REC" blinks on the display.
- ⑥ Press the ●/|| (REC/PAUSE) button again to begin recording to the direction of lightening PLAY (◀ or ►) indicator or press the ◀ or ► button to begin recording to the selected play direction.

5. CD to tape synchronized recording.

NOTE : Use only normal tapes.

- ① Load a disc.
- ② Insert a blank tape into deck.
- ③ Select a play mode by pressing the PLAY MODE(TAPE) button repeatedly.

In ➤ mode you can record forward(►) only and in ➤◀ or ➤◀➤ mode you can record from forward(►) to backward(◀) .
- ④ Press the FUNCTION button repeatedly to enter the CD mode so that 'CD' is appeared on the display.

Make the CD stop status if the CD is playing.
- ⑤ Press the CD SYNC. button to start recording.

The CD synchronized recording begins and stops automatically at the end.
When the tape auto reverse to backward(◀) the CD will restart the current track from the beginning.

 - If you want to record certain titles only, programme these before the CD synchronized recording.
 - If you want to record from the desired track, select the desired track with the ◀◀◀◀ or ▶▶▶▶ button before commencing CD synchronized recording.

SLEEP TIMER FUNCTION (remote control only)

1. To select the time to turn off:

Press the SLEEP button. (remote control only)
In the display you can see SLEEP and 90 for about 5 seconds. This means that the system turns off automatically after 90 minutes.
Each time the button is pressed the time interval before it turns off is reduced by 10 minutes. i.e. 80...70... etc.
Select the desired time to turn off.

2. To check the time to turn off:

While the sleep function is active press the

SLEEP button briefly. The time remaining until it turns off is displayed for about 5 seconds.

NOTE:

If you press the SLEEP button while the sleep time is displayed, the SLEEP time is set again.

3. To turn off the sleep function:

If you wish to stop the function press the SLEEP button repeatedly until 10 appears, and then press the SLEEP button once again while 10 is displayed.

TIMER FUNCTION

With the TIMER function you can have the radio reception and recording, CD play, tape play or auxiliary source play and recording turned on and off at the time desired.

1. Check the current time.
2. Press the **⌚** TIMER button to enter the timer setting mode. (If you want to correct the previous memorized TIMER, press and hold the **⌚** TIMER button more than 2 seconds.)
The previous memorized timer on time and the “**⌚**” appears in the display. Each function : TAPE-AUX-TUNER-CD flashes in the display in turn.
3. Press the SET/CNT RESET/ CD PAUSE button during flashing the desired function.
4. If you select the TUNER or AUX.
“REC” and “PLAY” flash in the display by turns for about 3 seconds.
Press the SET/CNT RESET/ CD PAUSE button to confirm the desired operating mode.
REC: TUNER or AUX recording and play
PLAY: TUNER or AUX play only
 - If you have selected the CD or TAPE, skip this 4 step.
5. When you have selected the TUNER;
Select the previous memorized preset number with the TUNING/TIME DOWN/UP buttons and press the SET/CNT RESET/ CD PAUSE button. The hour with ON display flashes.
 - If you have selected the CD, TAPE or AUX, skip this 5 step.
6. Set the hour to switch on by pressing the TUNING/TIME DOWN/UP buttons

7. Press the SET/CNT RESET/CD PAUSE button to confirm the hour to switch on. The minute with ON display flashes.
8. Set the minute to switch on by pressing the TUNING/TIME DOWN/UP buttons.
9. Press the SET/CNT RESET/CD PAUSE button to confirm the minute to switch on. The hour with OFF now flashes in the display.
10. Set the hour to switch off by pressing the TUNING/TIME DOWN/UP buttons.
11. Press the SET/CNT RESET/CD PAUSE button.
12. Set the minute to switch off by pressing the TUNING/TIME DOWN/UP buttons.
13. Press the SET/CNT RESET/CD PAUSE button.
14. Adjust the volume by pressing the TUNING/TIME DOWN/UP buttons.
15. Press the SET/CNT RESET/CD PAUSE button.
⌚ appears and the timer setting has been perfected.
16. Switch the system off.
The selected function is automatically switched on and off at the time set.
17. To cancel or check the timer.

Each time the **⌚** TIMER button is pressed you can select the timer activating or cancel. You can also check the timer setting status.

To activate or check the timer, press the **⌚** TIMER button so that “**⌚**” lights up in the display.

To cancel the **⌚** TIMER, press the timer button so that “**⌚**” in the display goes out.

SPECIFICATIONS

• AMP

Output Power(6Ω, 2ch, T.H.D 10%) :20W+20W
Frequency Response : 20~20,000Hz

• FM Tuning Range(optional)

: 87.5~108 MHz or 65~74MHz
and 87.5~108MHz

S/N Ratio(98.1 MHz) : 60/55dB(Mono/Stereo)

• MW(AM) Tuning Range(optional)

:522~1,611kHz, 530~1,720 kHz
or 530~1,610 kHz

Usable Sensitivity : 55dB

• LW(optional) Tuning Range(optional)

:153~281kHz, 146~290 kHz
or 163~281kHz (optional)

Usable Sensitivity : 60dB

• SW(optional) Tuning Range : 5.8~18.0MHz

• DECK S/N Ratio : 50dB

Cross Talk: 55dB

Channel Separation : 50dB

Erase Ratio : 65dB.

• CD-Frequency Response : 40~20,000Hz

S/N Ratio : 78dB

T.H.D : 0.1%

• Dimensions(WxHxD) :161x249x275 mm

• Weight(net) : 4.2 kg

• Power Requirements

: Refer to the back panel of the system.

• Speaker System(optional, FE-217E)

Impedance : 6Ω

Rated Input Power : 20W

Max Input Power : 40W

Frequency Response : 65~20,000 Hz,

Dimensions(net) :153(W)x240(H)x227(D)mm

Weight(net) : 2.24 kg

NOTE:

Designs and specifications are subject to change without notice for improvement.