

INSTALLATION INSTRUCTIONS

SINGLE SPLIT WALL MOUNTED AIR CONDITIONER

- Please read this instruction sheet completely before installing the product.
- When the power cord is damaged, replacement work shall be performed by authorized personnel only.
- Installation work must be performed in accordance with the national wiring standards by authorized personnel only.

Installation Parts Provided

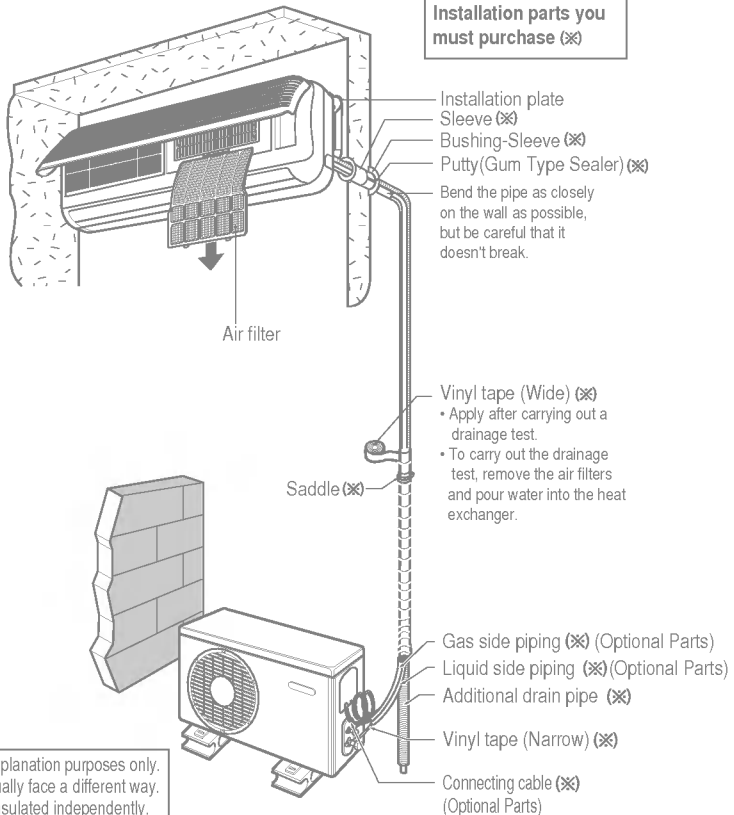
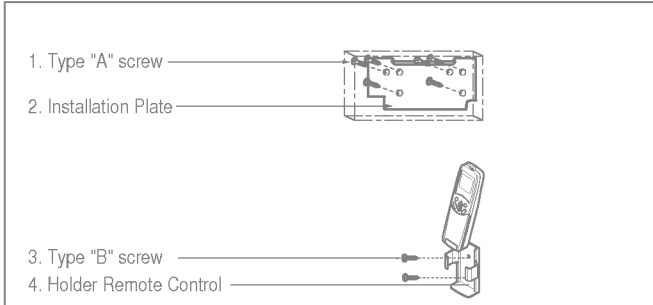

- This illustration is for explanation purposes only.
- The indoor unit will actually face a different way.
- Copper lines must be insulated independently.

The following should be always observed for safety.....3

Installation of indoor, outdoor unit.....4

- Installation plate
- Four type "A" screws
- Connecting cable

- Level gauge
- Screw driver
- Electric drill
- Hole core drill(ø70mm)

Flaring work and connection of piping6

Connection of piping(Indoor)7
For right rear piping
For left rear piping
Connection of piping(Outdoor)10

- Pipes: Gas side3/8", 1/2", 5/8", 3/4"
Liquid side1/4", 3/8"
(Refer to page 4)
- Insulation materials
- Additional drain pipe
(Outer Diameter.....15.5mm)

- Flaring tool set
- Specified torque wrenches
1.8kg·m, 4.2kg·m, 5.5kg·m, 6.6kg·m
(different depending on model No.)
(Refer to page 10)
- Spanner.....Half union

Connecting the cable between indoor unit and outdoor unit11

Checking the drainage and forming the piping13

- A glass of water
- Screw driver

Air purging14

- Hexagonal wrench(4mm)
- Gas-leak detector
- Vacuum pump
- Gauge manifold

Test running16

- Owner's manual
- Thermometer
- Holder Remote Control



THE FOLLOWING SHOULD BE ALWAYS OBSERVED FOR SAFETY

- Be sure to read "THE FOLLOWING SHOULD BE ALWAYS OBSERVED FOR SAFETY" before installing the air conditioner.
- Be sure to observe the cautions specified here as they include important items related to safety.
- The indications and meanings are as follows.



WARNING

: Could lead to death, serious injury, etc.



CAUTION

: Could lead to serious injury in particular environments when operated incorrectly.

- After reading this instructions, be sure to keep it together with the owner's manual in a handy place on the customer's site.



WARNING

Incorrect installation could cause injury due to fire, electric shock, the unit falling or leakage of water. Consult the dealer from whom you purchased the unit or special installer.

Install the unit securely in a place which can bear the weight of the unit's.

When installed in an insufficiently strong place, the unit could fall causing injury.

Use the specified wires to connect the indoor and outdoor units securely and attach the wires firmly to the terminal board connecting sections so the stress of the wires is not applied to the sections.

Incorrect connection and attachment could cause fire.

Attach the electrical part cover to the indoor unit and the service panel to the outdoor unit securely.

If the electrical part covers of the indoor unit and/or the service panel of the outdoor unit are not attached securely, it could result in a fire or electric shock due to dust, water, etc.

Perform the installation securely referring to the installation instruction.

Incorrect installation could cause a personal injury due to fire, electric shock, the unit falling or leakage of water.

Perform electrical work according to the installation manual and be sure to use a dedicated circuit.

If the capacity of the power circuit is insufficient or there is incomplete electrical work, it could result in a fire or an electric shock.

Check that the refrigerant gas does not leak after installation is completed.

Be sure to use the part provided or specified parts for the installation work.

The use of defective parts could cause an injury due to a fire, electric shock, the unit's falling, etc.



CAUTION

Do not install the unit in a place where a flammable gas leaks.

If gas leaks and accumulates in the area surrounding the unit, it could cause an explosion.

Perform the drainage/piping work according to the installation instruction.

If there is a defect in the drainage/piping work, water could leak from the unit and household goods could come wet and be damaged.

INSTALLATION OF INDOOR, OUTDOOR UNIT

Read completely, then follow step by step.

Select the best location

A Indoor unit

- Do not have any heat or steam near the unit.
- Select a place where there are no obstacles in front of the unit.
- Make sure that condensation drainage can be conveniently routed away. Do not install near a doorway.
- Ensure that the space around the left and right of the unit is more than "A". The unit should be installed as high on the wall as possible, allowing a minimum of "B" from ceiling.
- Use a stud finder to locate studs to prevent unnecessary damage to the wall.

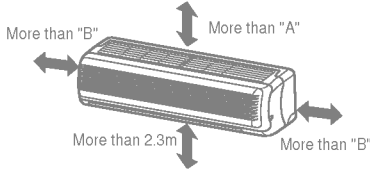

Install the indoor unit on the wall where the height from the floors more than 2.3 meters.

Grade	Clearance(cm)	
	A	B
5K~28K	10	5
30K~38K	30	12

B Outdoor unit

- If an awning is built over the unit to prevent direct sunlight or rain exposure, make sure that heat radiation from the condenser is not restricted.
- Ensure that the space around the back and sides is more than 10cm. The front of the unit should have more than 70cm of space.
- Do not place animals and plants in the path of the warm air.
- Take the air conditioner weight into account and select a place where noise and vibration are minimum.
- Select a place so that the warm air and noise from the air conditioner do not disturb neighbors.

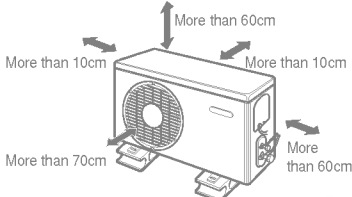

C Rooftop Installations:

- If the outdoor unit is installed on a roof structure, be sure to level the unit. Ensure the roof structure and anchoring method are adequate for the unit location.
- Consult local codes regarding rooftop mounting.



Piping length and elevation

Capacity (Btu/h)	Pipe Size		Standard Length (m)	Max. Elevation B (m)	Max. Length A (m)	Additional Refrigerant (g/m)
	GAS	LIQUID				
5k~14k	3/8"(Ø9.52)	1/4"(Ø6.35)	4 or 7.5	7	15	20
	1/2"(Ø12.7)	1/4"(Ø6.35)	4 or 7.5	7	15	20
18k~28k	1/2"(Ø12.7)	1/4"(Ø6.35)	4 or 7.5	15	30	20
	5/8"(Ø15.88)	1/4"(Ø6.35)	4 or 7.5	15	30	20
30k~38k	5/8"(Ø15.88)	3/8"(Ø9.52)	4 or 7.5	15	30	30
	3/4"(Ø19.05)	3/8"(Ø9.52)	7.5	15	30	50

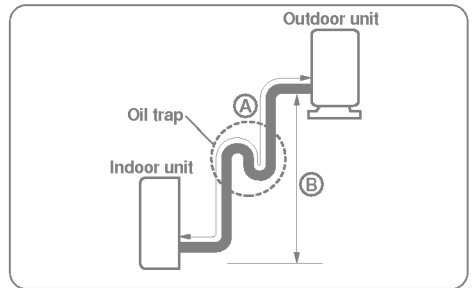
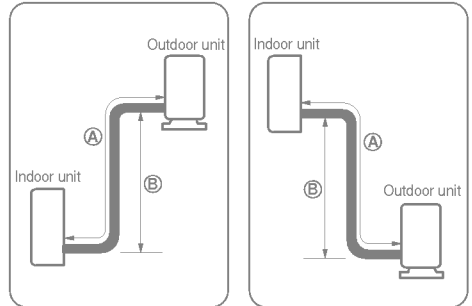

If case more than 5m



- Capacity is based on standard length and maximum allowance length is on the basis of reliability.
- Oil trap should be installed every 5~7 meters.

3 How to fix installation plate

The wall you select should be strong and solid enough to prevent vibration

A Mount the installation plate on the wall with 6 type "A" screws. If mounting the unit on a concrete wall, use anchor bolts.

■ Mount the installation plate horizontally by aligning the centerline using a level.

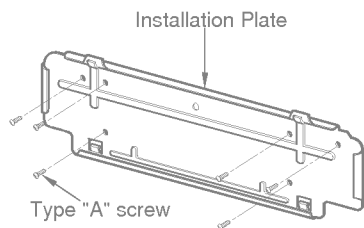

B Measure the wall and mark the centerline. It is also important to use caution concerning the location of the installation plate—routing of the wiring to power outlets is through the walls typically. Drilling the hole through the wall for piping connections must be done safely.

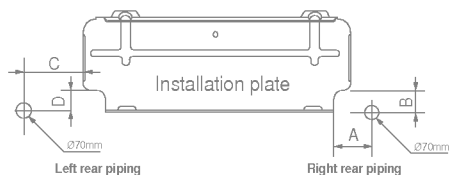

CHASSIS (Grade)	Distance (mm)			
	A	B	C	D
SJ	90	20	80	20
SL, SK	45	40	80	20
SQ, SW	75	12	80	12
SR	0	40	20	40
ST	105	0	210	0

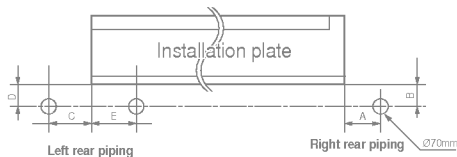

CHASSIS (Grade)	Distance (mm)				
	A	B	C	D	E
SM	180	115	-	115	50
SN	180	115	195	115	-

4 Drill a hole in the wall

■ Drill the piping hole with a $\varnothing 70\text{mm}$ hole core drill. Drill the piping hole at either the right or the left with the hole slightly slanted to the outdoor side.

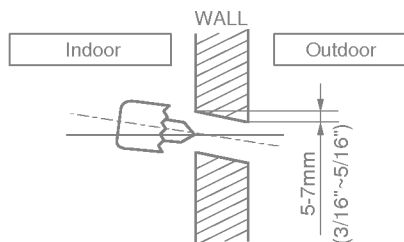

5 Installation instructions of telephone control (Optional)

- Open the Front Grille.
- Pass Telephone Control Cord Wire through the hole which the power cord goes through.
- Connect Telephone Control Cord Wire to the phone jack of telephone PCB of Control Box.
- Fix Telephone Control Cord Wire inside Control box so as not to disconnect.
- Close the Front Grille.

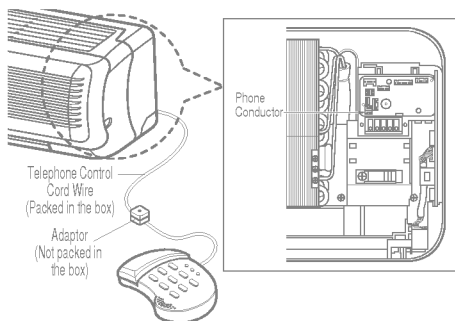

Answering telephone / Normal telephone (Not packed in the box)

FLARING WORK AND CONNECTION OF PIPING

Flaring work

Main cause for refrigerant leakage is due to defect in the flaring work. Carry out correct flaring work using the following procedure.

A Cut the pipes and the cable.

- Use the piping kit accessory or pipes purchased locally.
- Measure the distance between the indoor and the outdoor unit.
- Cut the pipes a little longer than the measured distance.
- Cut the cable 1.5m longer than the pipe length.

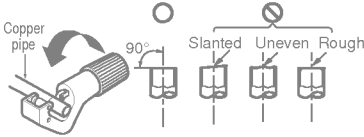

B Burr removal

- Completely remove all burrs from the cut cross section of pipe/tube.
- Put the end of the copper tube/pipe in a downward direction as you remove burrs in order to avoid dropping burrs into the tubing.

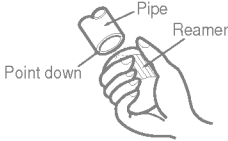

C Putting nut on

- Remove flare nuts attached to indoor and outdoor unit, then put them on pipe/tube having completed burr removal. (not possible to put them on after flaring work)

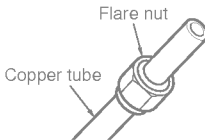

D Flaring work

- Firmly hold copper pipe in a die in the dimension shown in the table above.

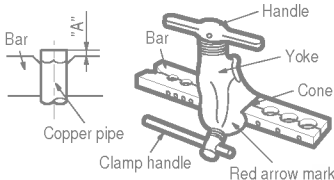

- Carry out flaring work using flaring tool as shown below.

Outside diameter		A
mm	inch	mm
Ø6.35	1/4	0~0.5
Ø9.52	3/8	0~0.5
Ø12.7	1/2	0~0.5
Ø15.88	5/8	0~1.0
Ø19.05	3/4	1.0~1.3

E Check

- Compare the flared work with figure below.
- If flare is noted to be defective, cut off the flared section and re-flare it.

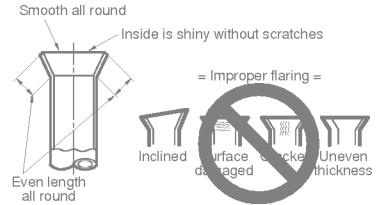

2 Connection of piping -- Indoor

- Preparing the indoor unit's piping and drain hose for installation through the wall.
- Remove the plastic tubing retainer (see illustration below) and pull the tubing and drain hose away from chassis.
- Replace the plastic tubing holder in the original position. (Optional)

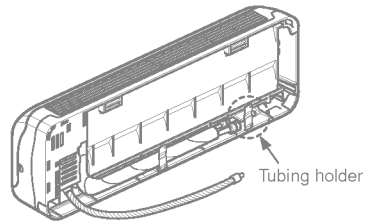

CAUTION

When install, make sure that the remaining parts must be removed clearly so as not to damage the piping and drain hose, especially power cord and connecting cable.

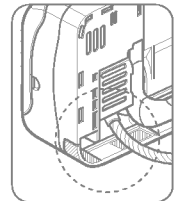

For right rear piping

- A** Route the indoor tubing and the drain hose in the direction of rear right.

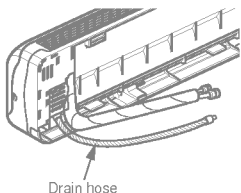

- B** Insert the connecting cable into the indoor unit from the outdoor unit through the piping hole.

- Do not connect the cable to the indoor unit.
- Make a small loop with the cable for easy connection later.

- C** Tape the tubing, drain hose, and the connecting cable. Be sure that the drain hose is located at the lowest side of the bundle. Locating at the upper side can cause drain pan to overflow inside the unit.

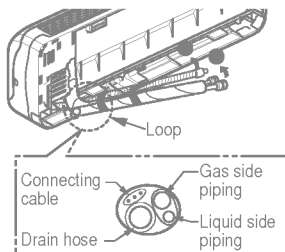

NOTE: If the drain hose is routed inside the room, insulate the hose with an insulation material* so that dripping from "sweating"(condensation) will not damage furniture or floors.

*Foamed polyethylene or equivalent is recommended.

D Indoor unit installation

- Hook the indoor unit onto the upper portion of the installation plate.(Engage the two hooks of the rear top of the indoor unit with the upper edge of the installation plate.) Ensure that the hooks are properly seated on the installation plate by moving it left and right.

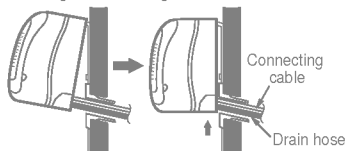

Press the lower left and right sides of the unit against the installation plate until the hooks engage into their slots(clicking sound).

E Connecting the pipings to the indoor unit and drain hose to drain pipe.

- Align the center of the pipes and sufficiently tighten the flare nut by hand.

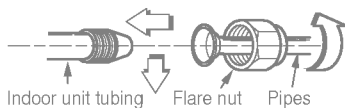

- Tighten the flare nut with a wrench.

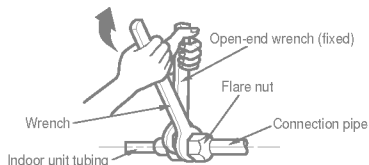

Outside diameter		Torque
mm	inch	kg·m
Ø6.35	1/4	1.8
Ø9.52	3/8	4.2
Ø12.7	1/2	5.5
Ø15.88	5/8	6.6
Ø19.05	3/4	6.6

- When extending the drain hose at the indoor unit, install the drain pipe.

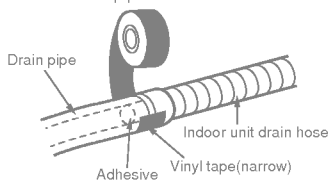

F Wrap the insulation material around the connecting portion.

- Overlap the connection pipe insulation material and the indoor unit pipe insulation material. Bind them together with vinyl tape so that there is no gap.

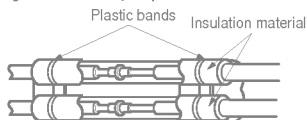

- Wrap the area which accommodates the rear piping housing section with vinyl tape.

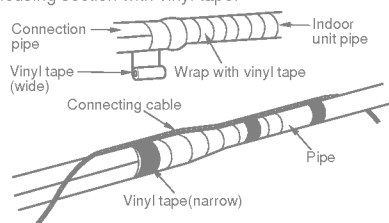

- Bundle the piping and drain hose together by wrapping them with vinyl tape for enough to cover where they fit into the rear piping housing section.

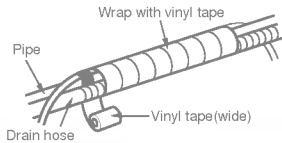

For left rear piping

- A** Route the indoor tubing and the drain hose to the required piping hole position.

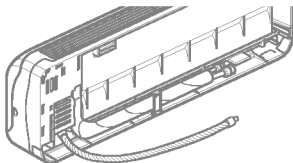

- B** Insert the piping, drain hose, and the connecting cable into the piping hole.

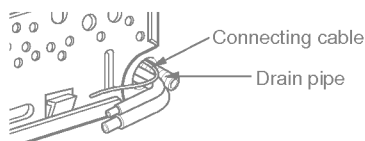

- C** Insert the connecting cable into the indoor unit.

- Don't connect the cable to the indoor unit.
- Make a small loop with the cable for easy connection later.

- D** Tape the drain hose and the connecting cable.

- Connecting cable

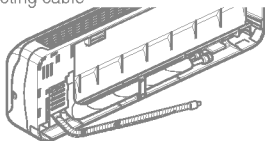

- E** Indoor unit installation

- Hang the indoor unit from the hooks at the top of the installation plate.
- Insert the spacer etc. between the indoor unit and the installation plate and separate the bottom of the indoor unit from the wall.

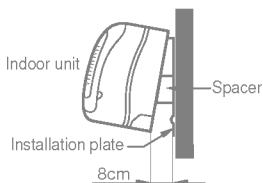

- F** Connecting the pipings to the indoor unit and the drain hose to drain pipe.

- Align the center of the pipes and sufficiently tighten the flare nut by hand.

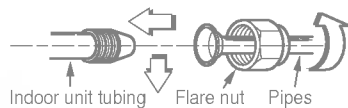

- Tighten the flare nut with a wrench.

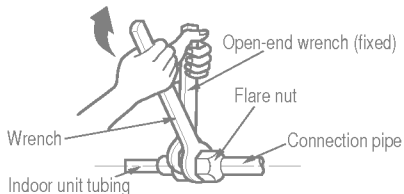

Outside diameter		Torque
mm	inch	kg·m
Ø6.35	1/4	1.8
Ø9.52	3/8	4.2
Ø12.7	1/2	5.5
Ø15.88	5/8	6.6
Ø19.05	3/4	6.6

- When extending the drain hose at the indoor unit, install the drain pipe.

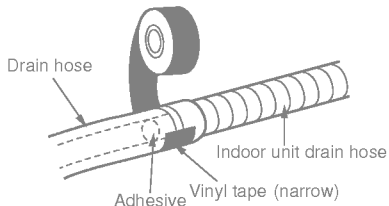

- G** Wrap the insulation material around the connecting portion.

- Overlap the connection pipe heat insulation and the indoor unit pipe heat insulation material. Bind them together with vinyl tape so that there is no gap.

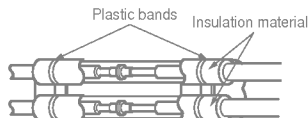

- Wrap the area which accommodates the rear piping housing section with vinyl tape.

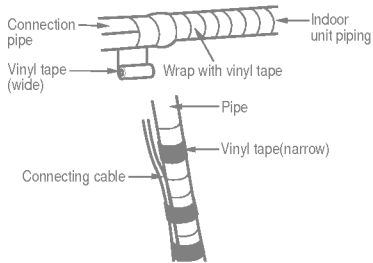

- Bundle the piping and drain hose together by wrapping them with cloth tape over the range within which they fit into the rear piping housing section.

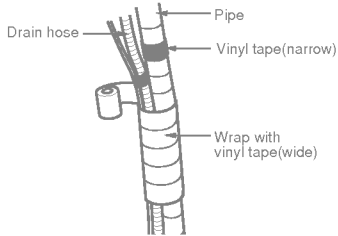

H *Reroute the pipings and the drain hose across the back of the chassis.*

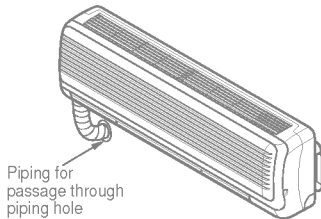

I *Set the pipings and the drain hose to the back of the chassis with the tubing holder.*

- Hook the edge of tubing holder to tap on chassis and push the bottom of tubing holder to be engaged at the bottom of chassis.

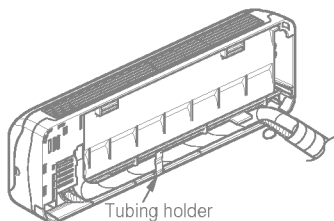

J *Indoor unit installation*

- Remove the spacer.
- Ensure that the hooks are properly seated on the installation plate by moving it left and right.

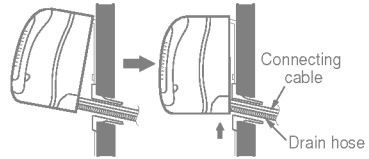

Press the lower left and right sides of the unit against the installation plate until the hooks engage into their slots (clicking sound).

Installation Information (For left piping)

- **Good case**
For left piping. Follow the instruction below.

- Press on the upper side of clamp. (A)

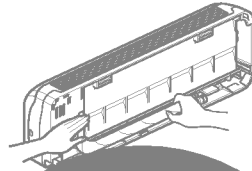

- Unfold the tubing to downward side.

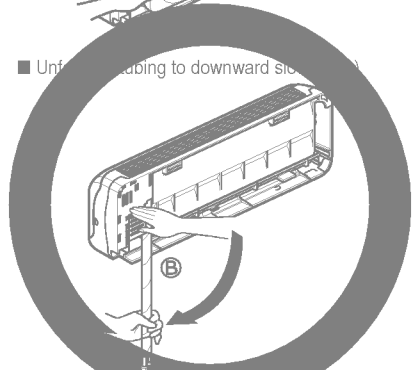

- Bend the tubing to the inside of chassis.

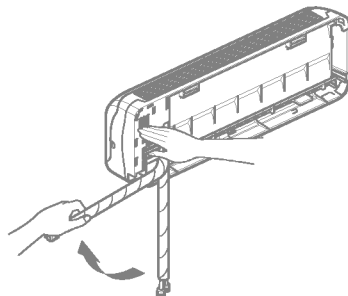



• **Bad case**

- Following bending type from right to left could cause problem of pipe damage.

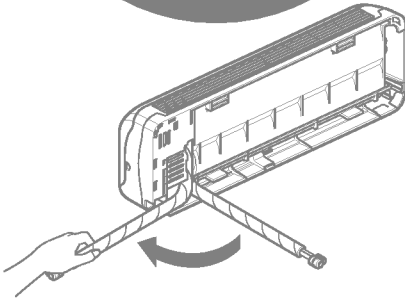
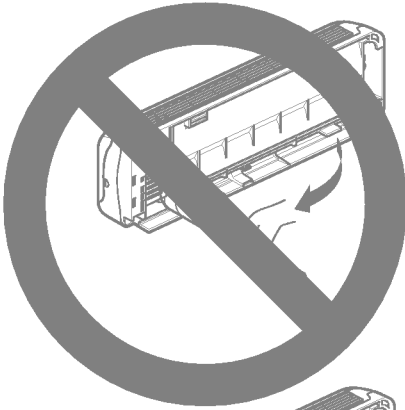
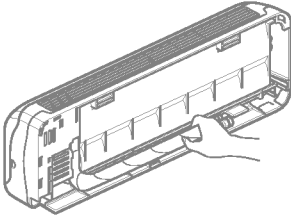

3 Connection of the pipes-Outdoor

- A** Align the center of the pipings and sufficiently tighten the flare nut by hand.

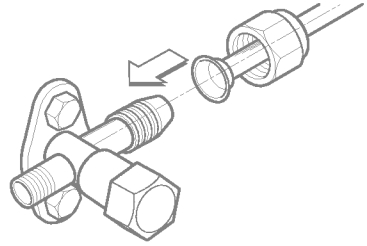

- B** Finally, tighten the flare nut with torque wrench until the wrench clicks.

- When tightening the flare nut with torque wrench, ensure the direction for tightening follows the arrow on the wrench.

Outside diameter		Torque
mm	inch	kg·m
Ø6.35	1/4	1.8
Ø9.52	3/8	4.2
Ø12.7	1/2	5.5
Ø15.88	5/8	6.6
Ø19.05	3/4	6.6

Outdoor unit

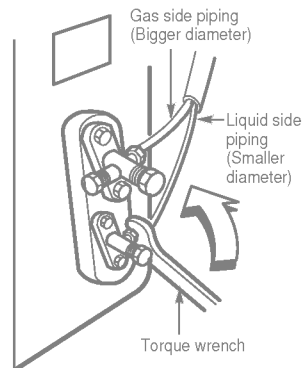

CONNECTING THE CABLE BETWEEN INDOOR UNIT AND OUTDOOR UNIT

Connect the cable to the Indoor unit.

- **Connect the cable to the indoor unit by connecting the wires to the terminals on the control board individually according to the outdoor unit connection.** (Ensure that the color of the wires of the outdoor unit and the terminal No. are the same as those of the indoor unit.)

The earth wire should be longer than the common wires.

The above circuit diagram is subject to change without notice.

When installing, refer to the circuit diagram on the control box inside Indoor Unit.

- When installing, refer to the circuit diagram on the Control Box of Indoor Unit.
- When installing, refer to the wiring diagram on the Control Cover Inside Outdoor Unit.



- The above circuit diagram is subject to change without notice.
- Be sure to connect wires according to the wiring diagram.
- Connect the wires firmly, so that not to be pulled out easily.
- Connect the wires according to color codes by referring the wiring diagram.



If a power plug is not to be used, provide a circuit breaker between power source and the unit as shown below.

Main power source

Air
Conditioner

Circuit Breaker
Use a circuit
breaker or time
delay fuse.



The power cord connected to the "A" unit should be complied with the following specifications (Type "B" approved by HAR or SAA).

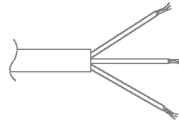

(mm²)

NORMAL CROSS-SECTIONAL AREA	Grade					
	5k~9k	12k~14k	18k	24k~28k	30k, 32k	36k, 38k
	0.75	1.0	1.5	2.5	2.5	5.5
Unit(A)	Indoor	Indoor	Indoor	Indoor	Outdoor	Outdoor
Cable Type(B)	H05VV-F	H05VV-F	H05VV-F	H05VV-F	H05RN-F	H05RN-F

The power connecting cable connected to the indoor and outdoor unit should be complied with the following specifications (Type "B" approved by HAR or SAA).

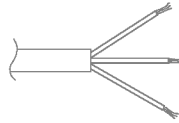

(mm²)

NORMAL CROSS-SECTIONAL AREA	Grade		
	5k~14k	18k	24k~28k
	1.0	1.5	2.5
Cable Type(B)	H07RN-F	H07RN-F	H07RN-F

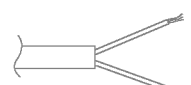

NORMAL
CROSS-SECTIONAL
AREA 0.75mm²

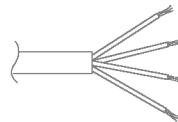

(mm²)

NORMAL CROSS-SECTIONAL AREA	Grade	
	30k, 32k	36k, 38k
	0.75	0.75
Cable Type(B)	H07RN-F	H07RN-F

2 Connect the cable to the outdoor unit

- A** Remove the control cover from the unit by loosening the screw.
Connect the wires to the terminals on the control board individually.
- B** Secure the cable onto the control board with the cord clamp.
- C** Refix the control cover to the original position with the screw.
- D** Use a recognized circuit breaker "A" between the power source and the unit.
A disconnecting device to adequately disconnect all supply lines must be fitted.

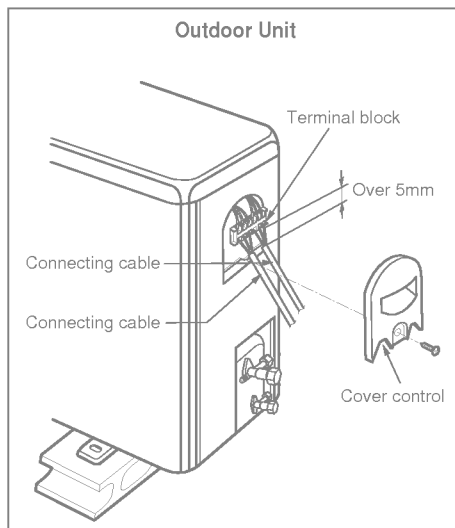

Circuit Breaker (A)	Grade				
	5k~14k	18k	24k~28k	30k, 32k	36k, 38k
	15	20	30	30	40



After the confirmation of the above conditions, prepare the wiring as follows:

- 1) Never fail to have an individual power circuit specifically for the air conditioner. As for the method of wiring, be guided by the circuit diagram posted on the inside of control cover.
- 2) The screw which fasten the wiring in the casing of electrical fittings are liable to come loose from vibrations to which the unit is subjected during the course of transportation. Check them and make sure that they are all tightly fastened. (If they are loose, it could cause burn-out of the wires.)
- 3) Specification of power source.
- 4) Confirm that electrical capacity is sufficient.
- 5) See to that the starting voltage is maintained at more than 90 percent of the rated voltage marked on the name plate.
- 6) Confirm that the cable thickness is as specified in the power source specification. (Particularly note the relation between cable length and thickness. (Refer to page 11))
- 7) Always install an earth leakage circuit breaker in a wet or moist area.
- 8) The following would be caused by voltage drop.
 - Vibration of a magnetic switch, which will damage the contact point, fuse breaking, disturbance of the normal function of the overload.
- 9) The means for disconnection from a power supply shall be incorporated in the fixed wiring and have an air gap contact separation of at least 3mm in each active(phase) conductors.

CHECKING THE DRAINAGE AND FORMING THE PIPINGS

1 Checking the drainage

A To remove the front panel from the indoor unit.

- Set the air direction louvers up-and-down to the position(horizontally) by hand.
- Remove the securing screws that retain the front panel. Pull the lower left and right sides of the grille toward you and lift it off.

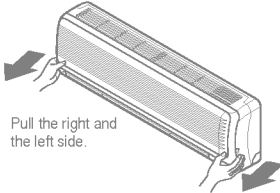

B To check the drainage.

- Pour a glass of water on the evaporator.
- Ensure the water flows through the drain hose of the indoor unit without any leakage and goes out the drain exit.

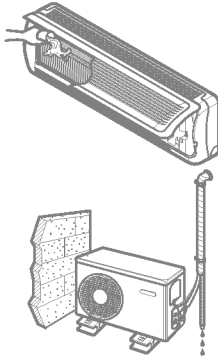

C Drain piping

- The drain hose should point downward for easy drain flow.

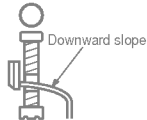

- Do not make drain piping.

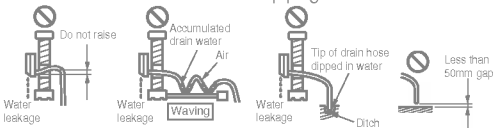

2 Form the piping

A Form the piping by wrapping the connecting portion of the indoor unit with insulation material and secure it with two kinds of vinyl tapes.

- If you want to connect an additional drain hose, the end of the drain outlet should be routed above the ground. Secure the drain hose appropriately.

B In cases where the outdoor unit is installed below the indoor unit perform the following.

- Tape the piping, drain hose and connecting cable from down to up.
- Secure the tapped piping along the exterior wall using saddle or equivalent.

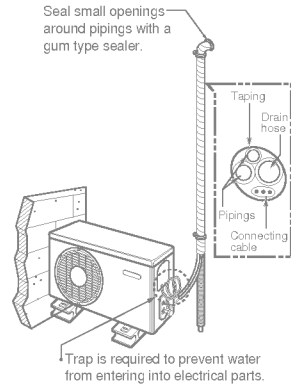

C In cases where the Outdoor unit is installed above the Indoor unit perform the following.

- Tape the piping and connecting cable from down to up.
- Secure the taped piping along the exterior wall. Form a trap to prevent water entering the room.
- Fix the piping onto the wall by saddle or equivalent.

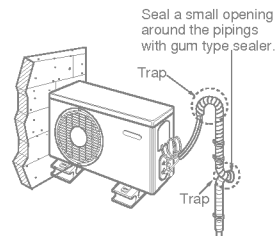

1 Air purging

Air and moisture remaining in the refrigerant system have undesirable effects as indicated below.

- Pressure in the system rises.
- Operating current rises.
- Cooling(or heating) efficiency drops.
- Moisture in the refrigerant circuit may freeze and block capillary tubing.
- Water may lead to corrosion of parts in the refrigeration system.

Therefore, the indoor unit and tubing between the indoor and outdoor unit must be leak tested and evacuated to remove any noncondensables and moisture from the system.

2 Air purging with vacuum pump

A Preparation

- Check that each tube(both liquid and gas side tubes) between the indoor and outdoor units have been properly connected and all wiring for the test run has been completed. Remove the service valve caps from both the gas and the liquid side on the outdoor unit. Note that both the liquid and the gas side service valves on the outdoor unit are kept closed at this stage.

B Leak test

- Connect the manifold valve(with pressure gauges) and dry nitrogen gas cylinder to this service port with charge hoses.



Be sure to use a manifold valve for air purging. If it is not available, use a stop valve for this purpose. The "Hi" knob of the manifold valve must always be kept close.

- Pressurize the system to no more than 150 P.S.I.G. with dry nitrogen gas and close the cylinder valve when the gauge reading reached 150 P.S.I.G. Next, test for leaks with liquid soap.



To avoid nitrogen entering the refrigerant system in a liquid state, the top of the cylinder must be higher than its bottom when you pressurize the system. Usually, the cylinder is used in a vertical standing position.

- Do a leak test of all joints of the tubing(both indoor and outdoor) and both gas and liquid side service valves.
Bubbles indicate a leak. Be sure to wipe off the soap with a clean cloth.
- After the system is found to be free of leaks, relieve the nitrogen pressure by loosening the charge hose connector at the nitrogen cylinder. When the system pressure is reduced to normal, disconnect the hose from the cylinder.

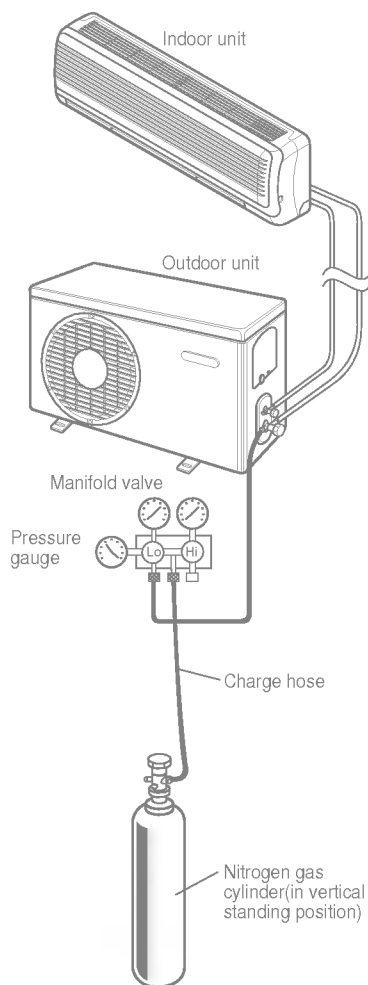

Soap water method

- (1) Remove the caps from the 2-way and 3-way valves.
- (2) Remove the service-port cap from the 3-way valve.
- (3) To open the 2-way valve turn the valve stem counterclockwise approximately 90°, wait for about 2~3 sec, and close it.
- (4) Apply a soap water or a liquid neutral detergent on the indoor unit connection or outdoor unit connections by a soft brush to check for leakage of the connecting points of the piping.
- (5) If bubbles come out, the pipes have leakage.

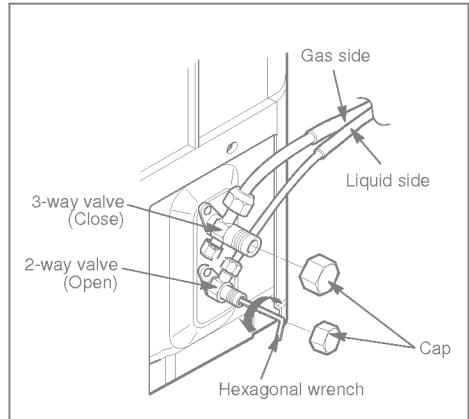

C Evacuation

- Connect the charge hose end described in the preceding steps to the vacuum pump to evacuate the tubing and indoor unit. Confirm the "Lo" knob of the manifold valve is open. Then, run the vacuum pump. The operation time for evacuation varies with tubing length and capacity of the pump. The following table shows the time required for evacuation.

Required time for evacuation when 30 gal/h vacuum pump is used	
If tubing length is less than 10m (33 ft)	if tubing length is longer than 10m (33 ft)
10 min. or more	15 min. or more

- When the desired vacuum is reached, close the "Lo" knob of the manifold valve and stop the vacuum pump.

D Finishing the job

- With a service valve wrench, turn the valve stem of liquid side valve counter-clockwise to fully open the valve.
- Turn the valve stem of gas side valve counter-clockwise to fully open the valve.
- Loosen the charge hose connected to the gas side service port slightly to release the pressure, then remove the hose.
- Replace the flare nut and its bonnet on the gas side service port and fasten the flare nut securely with an adjustable wrench. This process is very important to prevent leakage from the system.
- Replace the valve caps at both gas and liquid side service valves and fasten them tight.

This completes air purging with a vacuum pump. The air conditioner is now ready to test run.

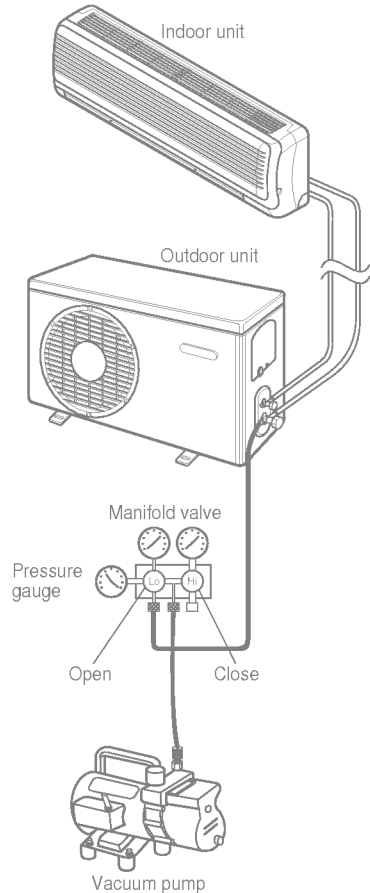

1. Check that all tubing and wiring have been properly connected.
2. Check that the gas and liquid side service valves are fully open.

A Prepare remote control

- 1 Remove the battery cover by pulling it according to the arrow direction.
- 2 Insert new batteries making sure that the (+) and (-) of battery are installed correctly.
- 3 Reattach the cover by pushing it back into position.

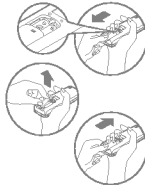

NOTE:

- Use 2 AAA(1.5volt) batteries. Do not use rechargeable batteries
- Remove the batteries from the remote control if the system is not going to be used for a long time.

B Settlement of outdoor unit

- Anchor the outdoor unit with a bolt and nut(ø10mm) tightly and horizontally on a concrete or rigid mount.
- When installing on the wall, roof or rooftop, anchor the mounting base securely with a nail or wire assuming the influence of wind and earthquake.
- In the case when the vibration of the unit is conveyed to the hose, secure the unit with an anti-vibration bushing.

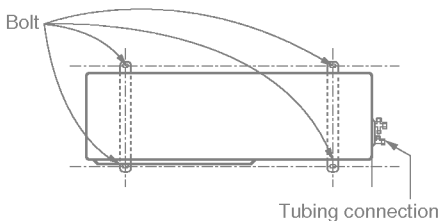

C Evaluation of the performance

Operate unit for 15~20 minutes, then check the system refrigerant charge:

1. Measure the pressure of the gas side service valve.
2. Measure the temperature of the intake and discharge of air.

3. Ensure the difference between the intake temperature and the discharge is more than 8 °C(46 °F) (Cooling) or (Heating).

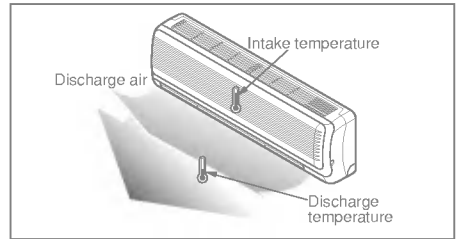

4. For reference; the gas side pressure of optimum condition is as below. (Cooling)

Refrigerant	Outside ambient TEMP.	The pressure of the gas side service valve.
R-22	35°C (95°F)	4~5kg/cm ² G(56.8~71.0 P.S.I.G.)
R-410A	35°C (95°F)	8.5~9.5kg/cm ² G(120~135 P.S.I.G.)

NOTE: If the actual pressure is higher than shown, the system is most likely over-charged, and charge should be removed. If the actual pressure are lower than shown, the system is most likely undercharged, and charge should be added. The air conditioner is now ready for use.

PUMP DOWN

This is performed when the unit is to be relocated or the refrigerant circuit is serviced.

Pump Down means collecting all refrigerant in the outdoor unit without loss in refrigerant gas.

CAUTION:

Be sure to perform Pump Down procedure with the unit cooling mode.

Pump Down Procedure

1. Connect a low-pressure gauge manifold hose to the charge port on the gas side service valve.
2. Open the gas side service valve halfway and purge the air from the manifold hose using the refrigerant gas.
3. Close the liquid side service valve(all the way in).
4. Turn on the unit's operating switch and start the cooling operation.
5. When the low-pressure gauge reading becomes 1 to 0.5kg/cm²G(14.2 to 7.1 P.S.I.G.), fully close the gas side valve stem and then quickly turn off the unit. At that time, Pump Down has been completed and all refrigerant gas will have been collected in the outdoor unit.