

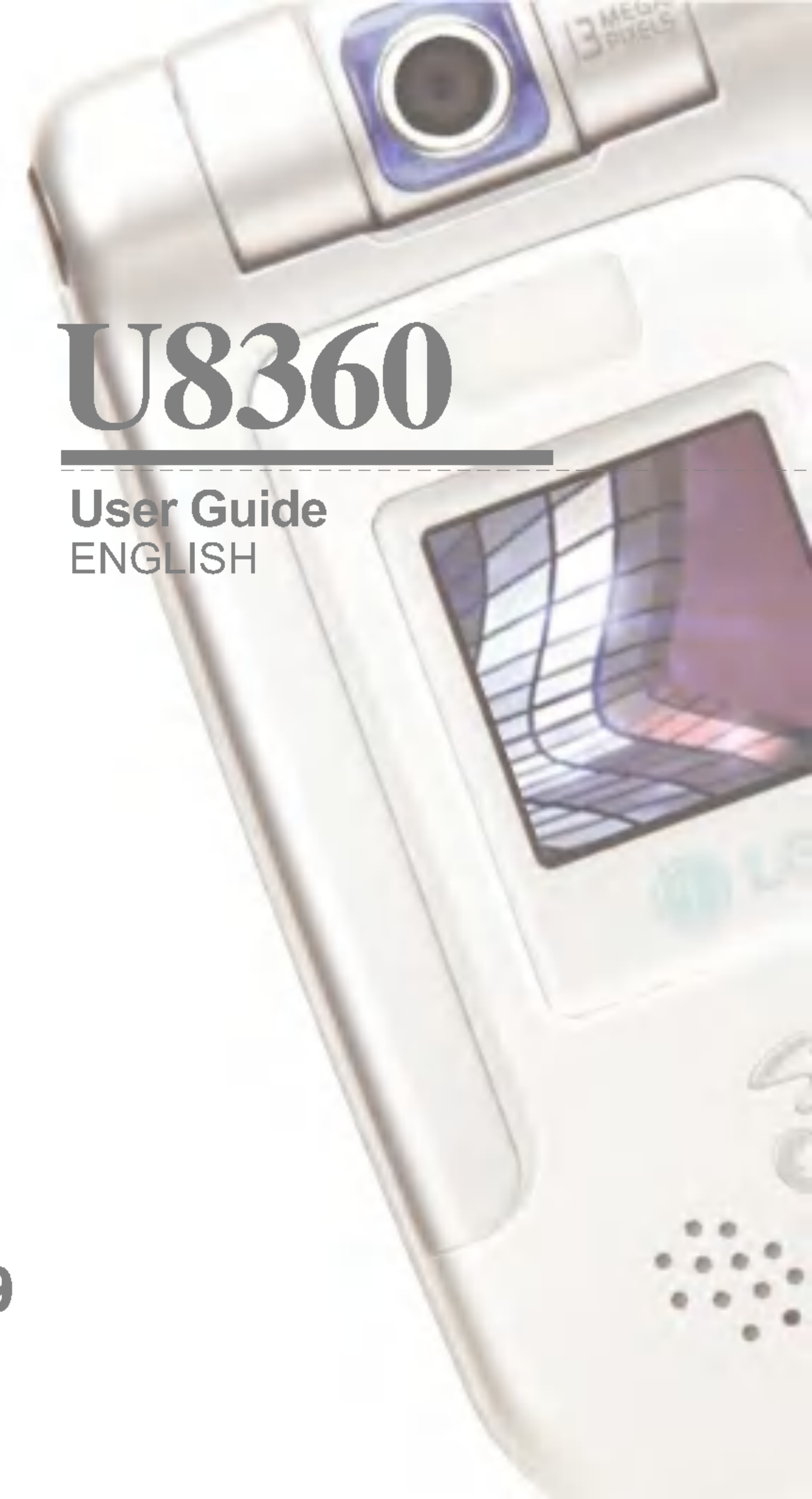

CE 0889

U8360

User Guide
ENGLISH



Disposal of your old appliance



1. When this crossed-out wheeled bin symbol is attached to a product it means the product is covered by the European Directive 2002/96/EC.
2. All electrical and electronic products should be disposed of separately from the municipal waste stream via designated collection facilities appointed by the government or the local authorities.
3. The correct disposal of your old appliance will help prevent potential negative consequences for the environment and human health.
4. For more detailed information about disposal of your old appliance, please contact your city office, waste disposal service or the shop where you purchased the product.

LIMITED WARRANTY

LG Electronics warrants to the original purchaser (end user) that the cellular product and its enclosed accessories will be free from defects in material and workmanship, according to the following terms and conditions:

1. WHAT THIS WARRANTY COVERS:

- (1) The limited warranty for the handset remains in effect for a period of 12 (twelve) months based on the date of purchase (except for the battery, where the Warranty Period shall be 6 months).
- (2) The limited warranty extends only to the original purchaser (end user) and is not assignable or transferable to any subsequent purchaser/end user.
- (3) During the warranty period LG or officially appointed service agent will repair or replace any defective product or parts thereof at its discretion.
- (4) This limited warranty is applicable to the customer/end user that purchased the product from an official dealer in the United Kingdom.
- (5) The purchaser (end user) must retain the original purchase invoice/till slip in order to enforce this limited warranty.

2. WHAT THIS WARRANTY DOES NOT COVER:

- (1) Defects or damages resulting from the misuse of this product.
- (2) Defects or damages from abnormal use, abnormal conditions, improper storage, exposure to moisture or dampness, unauthorized modifications, unauthorized repair, neglect, abuse, accident, alteration, improper installation, blown fuses, food or liquid spillage, acts of God and shipping damage.
- (3) Breakage or damage to antennas unless caused directly by defects in material or workmanship.
- (4) The cost of delivery or transportation of the product to the dealer or officially appointed service center will be borne by the purchaser (end user).

- (5)** Products received for repair by the dealer or authorized service center after the product warranty has expired.
- (6)** Products that have had the serial number removed or defaced.
- (7)** THIS LIMITED WARRANTY IS IN LIEU OF ALL OTHER WARRANTIES, EXPRESSED OR IMPLIED IN TERMS OF MARKETABILITY OR FITNESS FOR A PARTICULAR USE. SPECIFICALLY THE COMPANY WILL ACCEPT NO RESPONSIBILITY OR LIABILITY FOR CONSEQUENTIAL, INDIRECT, INCIDENTAL AND SPECIAL LOSS OR DAMAGE CAUSED BY OR DUE TO FAILURE OF OPERATION OR MALFUNCTION OF THE PRODUCT, OR ARISING FROM THE USE OR INABILITY TO USE THE PRODUCT.
- (8)** Damage resulting from the use of non-LG approved accessories.
- (9)** Scratches and damage caused by normal use.
- (10)** Products used outside published maximum ratings.
- (11)** Consumables such as fuses.
- (12)** Products that have been subject to an unauthorised removal or deactivation of the network operator-lock function.

Thank you for purchasing this LG U8360 handset. In the unlikely event that your handset needs to be repaired, please contact 3 Customer Services for information on how to return your handset for repair by dialing 0870.7330.333 or 333. Please have your IMEI number ready when you call (this can be found under the battery).

Welcome to your LG U8360 handset

User guides can be daunting things, can't they?
But don't worry, we've made this one as
simple as possible.



Your guide is designed to do two things.

First, there's an explanation on how to use your new LG U8360, so finding your way around the handset will soon become the second nature.

Then there's an introduction to the wide range of services offered, to make sure you get the best from them. If all you want to do is power up and get going, that's fine.

Emergency Services and Safety Precautions	10	Making and Answering calls	27
Getting Started	14	Making and Answering a video call.....	27
Using the Battery, Charger and USIM Card	14	Making a voice/video call.....	28
Installing the Battery.....	14	Making a voice/video call from Contacts.....	28
Removing the Battery.....	15	Making International Calls	28
Charging the Battery	16	Adjusting the Volume	29
Disconnecting the Charger.....	17	Answering a Call.....	29
Battery Information and Care	17	Signal Strength.....	29
Memory Information and Care	18	Entering Text	29
Installing the USIM card	19	Changing the Text Input Mode.....	30
		Using the T9 Mode.....	30
Getting to know your LG U8360	20	Using the ABC Mode.....	31
Familiarise yourself with its features	20	Using the 123 (Number) Mode	31
Your handset's home screen	22	Using the Symbol Mode.....	31
Display Information	23	Character chart.....	32
Your handset's keys and navigation	24		
Function of keys when phone is idle	25	Menu tree	33
		Screen	40
General Functions	26	Screen theme	40
Turning your handset on	26	Home screen	40
Turning your handset off	26	Outgoing call	40
Access Codes	26	Switch on.....	40
PIN code (4 to 8 digits).....	26	Switch Off.....	40
PIN2 code (4 to 8 digits).....	26	Front screen theme	40
PUK code (4 to 8 digits)	26	Home screen	40
PUK2 code (4 to 8 digits)	26	Outgoing call	40
Security code (4 to 8 digits).....	27	Menu style	41
Barring Password	27	Font	41

Backlight	41	Handset information	52
Handset theme	42	Reset settings	52
Greeting message	42		
Profiles	44	Browser	54
Settings	48	Home	54
Date & Time	48	Bookmarks	55
Time.....	48	Connect.....	55
Date	48	Send	55
Auto update date/time.....	48	Add new	55
Daylight saving	49	Edit	55
		Mark/Unmark.....	55
Network	49	Delete	55
Network selection.....	49	Saved pages	55
Preferred list	49	Go to URL	55
Access points	49		
		Security	56
Security	50	Settings	56
PIN code request	50	Profiles.....	56
Handset lock	50	Character encoding	56
Change codes	50	Scrolling control	56
		Show Image.....	56
Language	51	Cache	57
Memory status	51	Cookies	57
Common memory	52	Clear cache	57
Reserved memory	52	Clear cookie	57
USIM memory	52		
External Memory	52	Messages	62
		New message	62

Text message	62	Video camera	84
Multimedia message	62	Camera	85
Email.....	65	Voice recorder	86
Inbox	66	Settings	86
Mailbox	68	Video camera	86
Drafts	69	Camera	86
Outbox	69	Voice recorder	86
Sent items	69	Memory status	86
Templates	70	Contacts	88
Settings	70	Add new	88
Text message	70	Search	88
Multimedia message	71	Speed dials	88
Email	72	Groups	89
Videomail.....	73	Service dial numbers	89
Voicemail	73	Own number	89
ExpressLink.....	73	Settings	89
Info. Service.....	73	Display data.....	89
My stuff	76	Show image/avatar	89
Images	76	Copy all	89
Videos	77	Move all	90
Sounds	79	Clear contacts	90
Applications	82	Applications	92
External memory	82	My games & apps	92
Play lists	82	Download games & apps	92
Multimedia	84	Settings	92

Organiser	96	Currency.....	109
Calendar	96	Surface.....	109
To do	99	Length.....	110
To do Enquiry.....	99	Weight.....	110
Adding To do Items.....	99	Temperature.....	110
To do Delete.....	99	Volume.....	111
Finished/Not finished.....	99	Velocity.....	111
Mark/Unmark.....	99		
To do Detailed View.....	100	Calling	114
		Video calls	114
Memo	100	My picture size.....	114
Secret memo	101	My picture position.....	114
Date finder	101	Hide my picture.....	114
Dateulator	101	Substitute picture.....	114
Settings	102		
Calendar.....	102	Call history	114
Memory info... ..	102	Missed calls.....	115
Clear all.....	102	Received calls.....	115
		Dialled calls.....	115
Tools	104	All calls.....	115
Quick menu	104		
Alarm clock	105	Call duration	115
Connectivity	106	Last call.....	115
Bluetooth.....	106	Received calls.....	115
Server synchronisation.....	107	Dialled calls.....	115
Calculator	108	All calls.....	115
World time	108		
Unit converter	109	Call divert	116

Voice calls	116
Video calls	116
All fax calls.....	117
Call barring.....	117
Voice calls	117
Video calls	117
Deactivate all.....	118
Fixed dial numbers	118
Call waiting	118
Settings	119
Call reject.....	119
Send my number	120
Auto redial	120
Answer mode	120
Minute minder	120
Troubleshooting	122
Accessories.....	124
Glossary.....	126
Index	130



Guidelines for safe and efficient use

Read these simple guidelines. Breaking the rules may be dangerous or illegal.
Further detailed information is given in this manual.

Emergency Services and Safety Precautions

- Do not allow battery to come into direct contact with an electric outlet or car cigarette lighter socket
- Do not pierce battery with sharp objects
- Do not drop or subject the phone to physical shock
- When the battery has reached the end of its life, dispose of it in accordance with environmental regulations. Do not dispose of your battery in household rubbish.
- Do not immerse in water
- Do not disassemble or modify the battery
- Stop using the battery if abnormal heat, odour, discolouration, deformation, or abnormal conditions are detected during use, charge, or storage
- Do not use damaged or deformed batteries. In the unlikely event of a battery leak, take care to keep the battery discharge away from your eyes or skin.
- If the leakage does come into contact with the eyes or skin, please wash thoroughly in clean water and consult with a doctor
- The earpiece may become warm during normal use. The handset itself may become warm while the battery is being charged
- Use a damp or anti-static cloth to clean the handset. Do not use a dry cloth or electrostatically charged cloth. Do not use chemical or abrasive cleaners as these could damage the phone
- Retain the cardboard packing supplied with this handset. It should be used if the phone has to be returned for service. This packaging can be recycled when no longer required
- Remember to make backup copies of all important data on your handset

Aircraft safety

In accordance with CAA regulations, you must switch off your phone on aircraft. Mobile phone signals can interfere with aircraft equipment. Follow the instructions given by airline staff at all times

Hospital safety

Switch off your phone in areas where the use of handsets is prohibited. Follow the instructions given by the respective medical facility regarding the use of handsets on their premises

General safety

- Observe 'Turn off 2-way radio' signs, such as those near petrol stations, chemicals or explosives, and turn off your handset
- Do not allow children to play with the handset, charger or batteries
- Do not use the handset where blasting is in progress
- The operation of some medical electronic devices, such as hearing aids and pacemakers, may be affected if a handset is used next to them. Observe any warning signs and the manufacturer's recommendations

Road safety

- You MUST exercise the proper control of your vehicle at all times. Give your full attention to driving
- Observe all laws in respect to the use of mobile phones when driving
- Pull off the road and park before making or answering a call where it is safe to do so. UK law prohibits the use of hand held mobile phones when driving
- You MUST NOT stop on the hard shoulder of a motorway to answer or make a call, except in an emergency
- Switch off your handset at refueling points and petrol stations, even if you are not refueling your own car
- Do not store or carry flammable or explosive materials near your handset
- Electronic vehicle systems, such as anti-lock brakes, speed control and fuel injection systems are not normally affected by radio transmissions

Emergency Services and Safety Precautions

- The manufacturers of such equipment can advise if it is adequately shielded from radio transmissions. Consult your dealer and do not switch on the handset until it has been checked by qualified installers

Vehicles equipped with an air bag

An air bag inflates with great force. Do not place objects, including either installed or portable wireless equipment, in the area over the air bag or in the air bag deployment area. If in-vehicle wireless equipment is improperly installed and the air bag inflates, serious injury could result

Third party equipment

The use of third party equipment, cables or accessories, not made or authorized by LG, may invalidate the warranty of your handset and also adversely affect the handset's safety or operation

Service

The handset, batteries and charger contain no user-serviceable parts. LG recommend that your LG U8360 handset is serviced or repaired by an LG authorized service centre

Efficient use

The handset has an antenna. For optimum performance with minimum power consumption, please do not cover the antenna area with your hand. Covering the antenna affects call quality and may cause the handset to operate at a higher power level than required. This decreases talk and standby time.

Radio frequency energy

Your handset is a low-power radio transmitter and receiver. When it is turned on, it receives and transmits radio frequency (RF) energy (radio waves). The system that handles the call (the network) controls the power level at which the handset transmits.

- Further detailed information is given in this manual.

Exposure to radio frequency energy

Radio wave exposure and Specific Absorption Rate (SAR) information

- This handset model U8360 has been designed to comply with safety requirements for exposure to radio waves. This requirement is based on scientific guidelines that include safety margins designed to assure the safety of all persons, regardless of age and health
 - The radio wave exposure guidelines employ a unit of measurement known as the Specific Absorption Rate, or SAR. Tests for SAR are conducted using a standardized method with the phone transmitting at its highest certified power level in all used frequency bands
 - While there may be differences between the SAR levels of various LG phone models, they are all designed to meet the relevant guidelines for exposure to radio waves
 - The SAR limit recommended by the International Commission on Non-Ionizing Radiation Protection (ICNIRP), is 2W/kg averaged over ten (10) gramme of tissue
- The highest SAR value for this model phone tested by DASY3 for use at the ear is 0.883 W/kg (10g)
 - The SAR limit recommended by the Institute of Electrical and Electronics Engineers (IEEE), which is 1.6 W/kg averaged over one (1) gramme of tissue (for example USA, Canada, Australia and Taiwan).

Getting Started

Using the Battery, Charger and USIM Card

Installing the Battery

To install the battery, insert the bottom of the battery into the opening on the back of the phone. Then push the battery down until the latch clicks and then install battery cover.

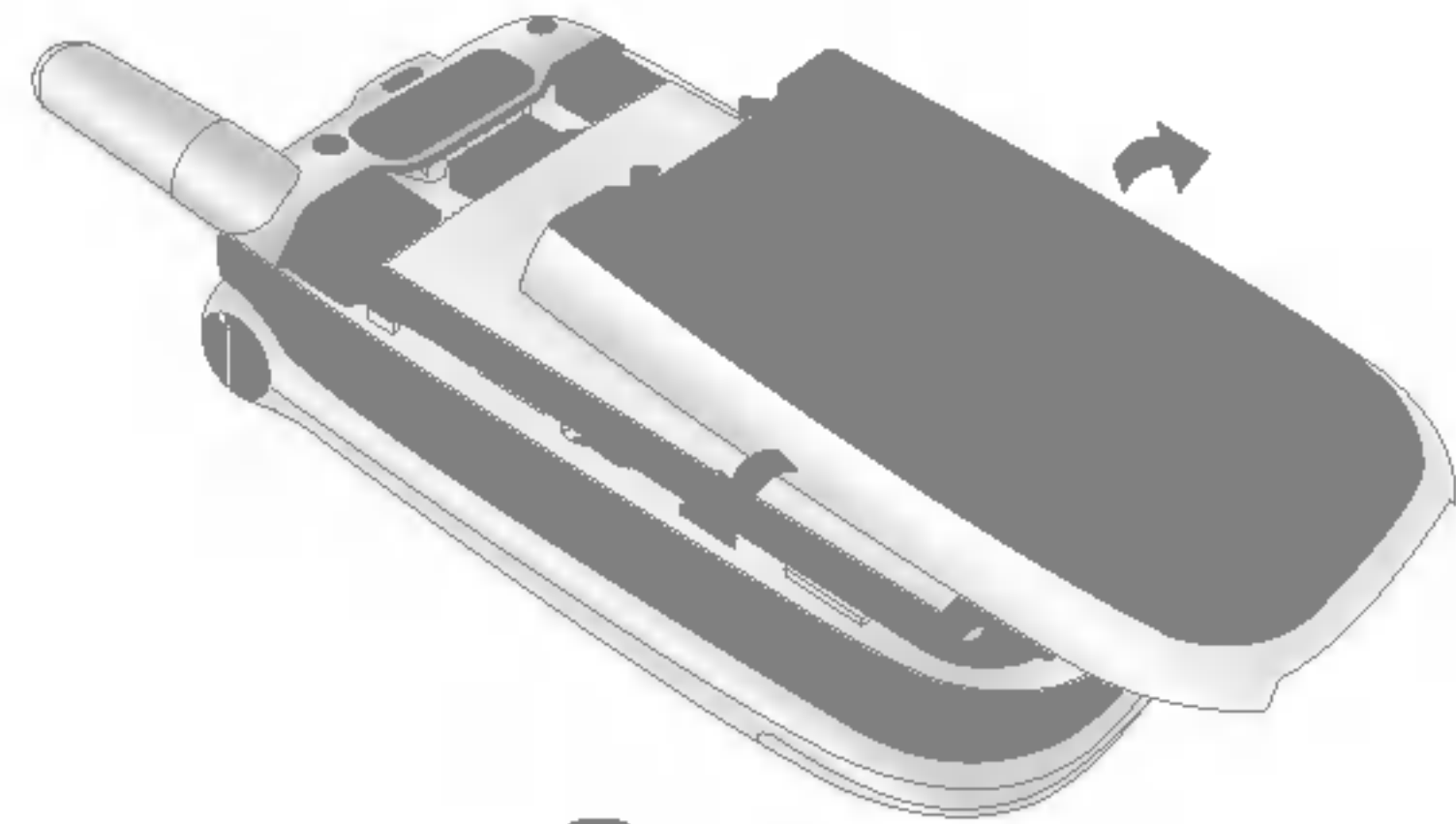
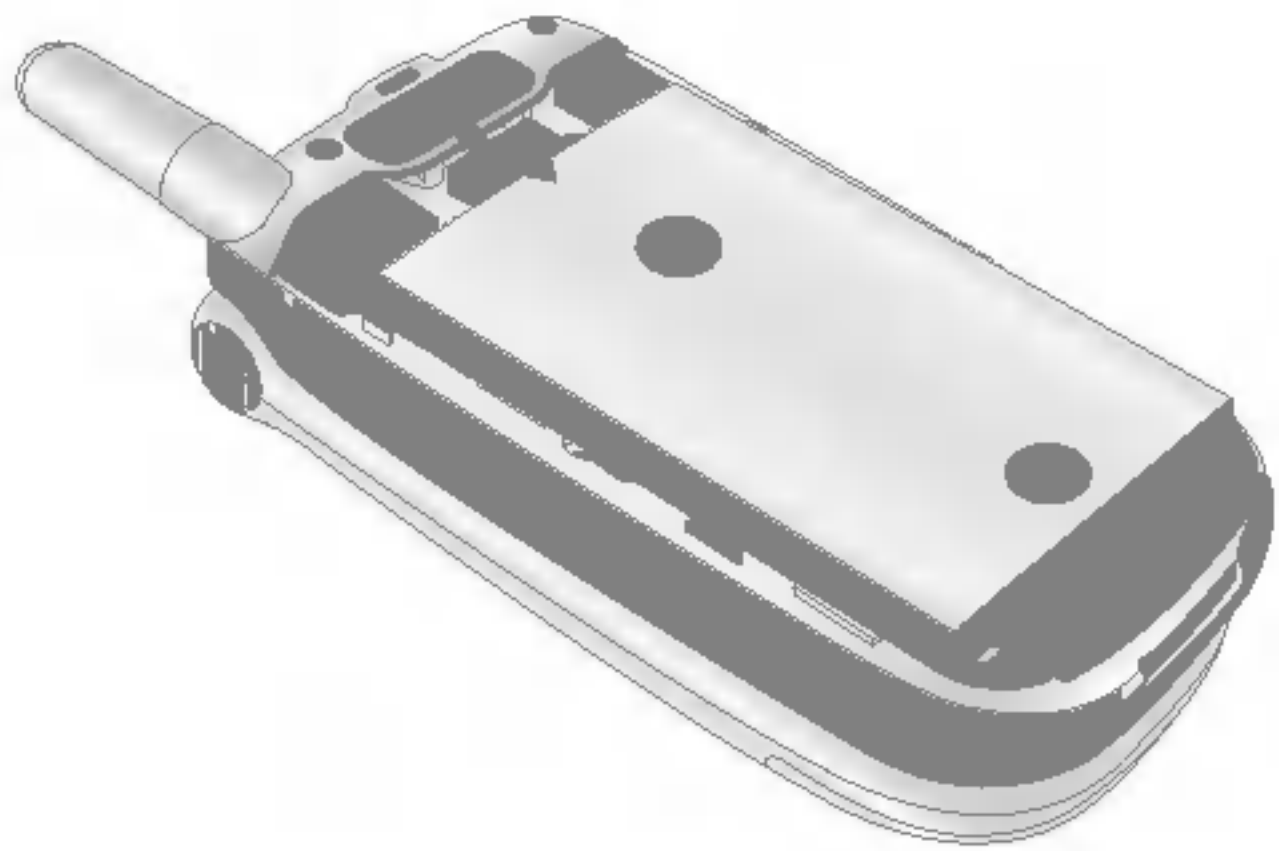

Removing the Battery

Turn the power off. (If power is left on, there is a chance you could lose the stored telephone numbers and messages.) Press the latches ① and open the battery cover ②. Then remove the battery.

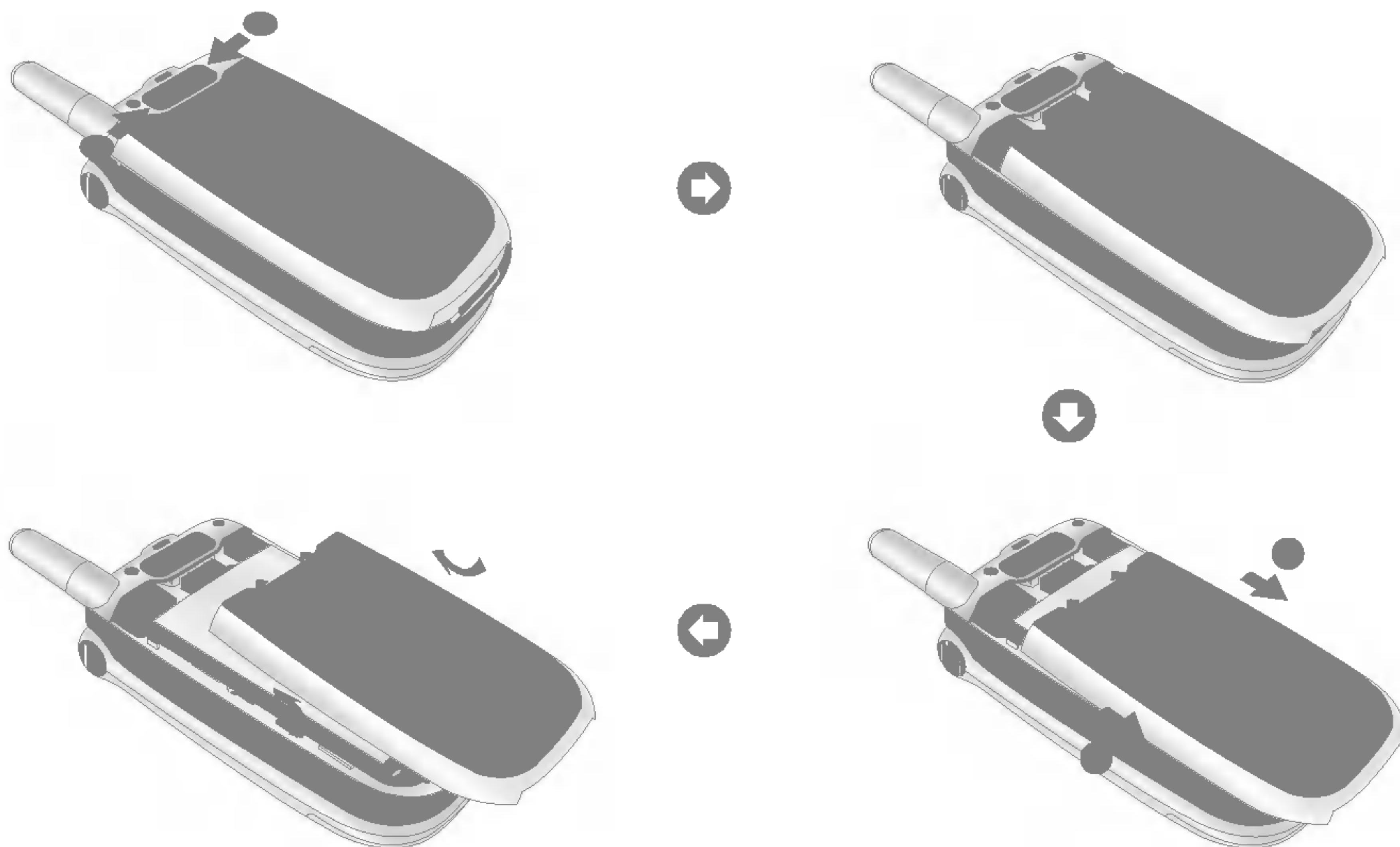

Getting Started

The battery is fully discharged and it will take sometime(under 30 minutes) to charge the battery to minimum operating level. When the red light is on, the handset can not be powered on. The red light will be turned off if the battery is charged to minimum operating level.

Warning

You can make video call with charger connected.

But if the battery capacity is under 10% the battery can be discharged when you use video call even though the charger is connected.

Charging the Battery

To use the charger provided with your phone:

1. With the battery in position on the phone, connect the lead from the charger to the bottom of the phone. Check that the arrow on the lead connector is facing towards the front of the phone.

2. Connect the charger to a standard AC wall outlet. Only use the charger that comes included with the package.

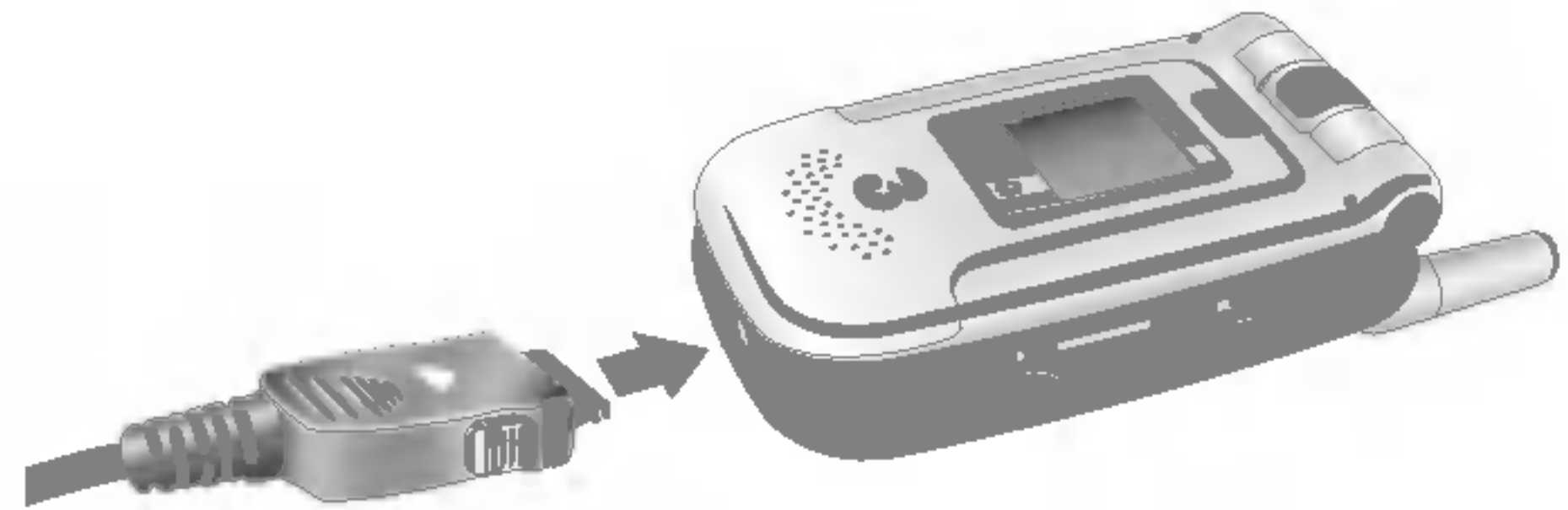

Warning

Do not force the connector as this may damage the phone and/or the charger.

Disconnecting the Charger

When charging is finished, disconnect the charger from the power outlet and from the phone by pressing on the gray tabs on both sides of the connector while pulling the connector out.



Notice

The battery delivered with your phone has to be fully charged before using it. Do not remove the battery or the USIM card while charging.

If your phone is being charged, the display will show the charging status.

If the battery fails to charge completely:

After turning the phone on and off, please attempt to recharge the battery.

After detaching and reattaching the battery, please attempt to recharge the battery.

Battery Information and Care

1. Never use an unapproved battery since this could damage the phone and / or battery and could cause the battery to explode.
2. The battery does not need to be fully discharged before recharging.
3. Use only LG approved chargers specific to your phone model since they are designed to maximize battery life.
4. Do not disassemble or short-circuit the battery.
5. Keep the battery's metal contacts clean.
6. Replace the battery when it no longer provides acceptable performance. The battery can be recharged several hundred times before replacement.

Getting Started

7. Recharge the battery after long periods of non-use to maximize battery life.
8. Do not expose the battery charger to direct sunlight or use it in areas of high humidity such as a bathroom.
9. Battery life will decrease if exposed to extremely hot or cold temperatures.
10. Battery life will vary due to usage patterns and environmental conditions.
11. The use of extended backlighting, Browser, and data connectivity kits affect battery life and talk/standby time.
4. When setting the theme of the idle screen, do not set the theme stored on the external memory directly to the idle screen, but only after copying it to the phone memory.
5. When setting pictures or photos stored on the external memory as the main theme, please perform the normal turning off procedure before removing external memory.

Memory Information and Care

1. Please be very careful to turn off the power before removing the battery while the phone or the external memory is being used.
 2. Do not remove memory while listening to music or displaying pictures stored on the external memory.
 3. When formatting on the PC, format on FAT types. The external memory only supports FAT (FAT12, FAT 16) format and not FAT32.
-

Installing the USIM card

Your USIM card contains your phone number, service details and contacts and must be inserted into your handset.

If your USIM card is removed then your handset becomes unusable until a valid one is inserted. Always disconnect the charger and other accessories from your handset before inserting and removing your USIM card.

Your USIM card may only be used in handsets which are enabled for 3 services. Any attempt to use the USIM card in other handsets may result in serious damage to the handset and may prevent you from being able to use it, including the making of emergency calls.

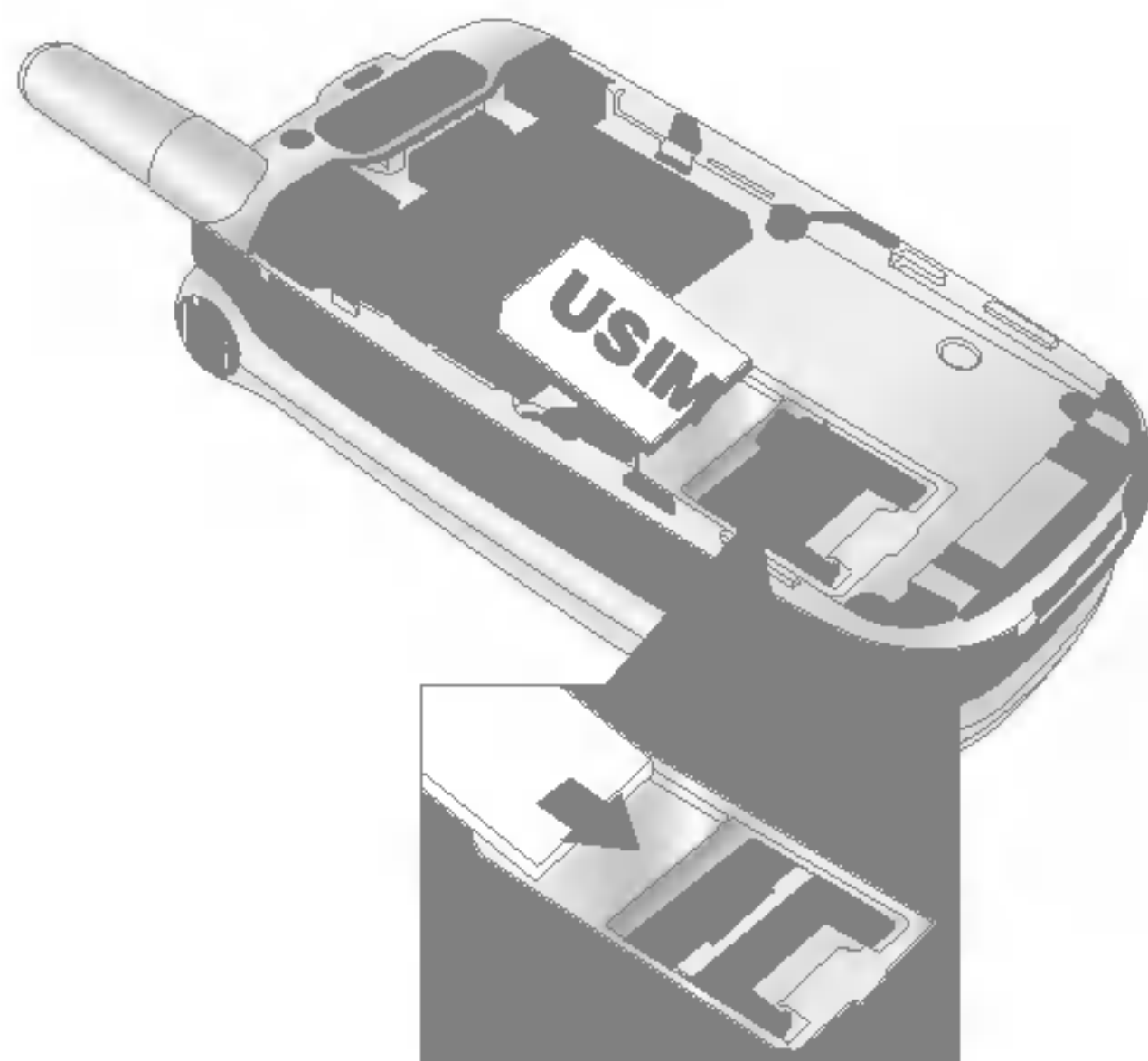

Notice

When you need to remove the USIM card, slide it towards the top of the phone and take it out of the holder.

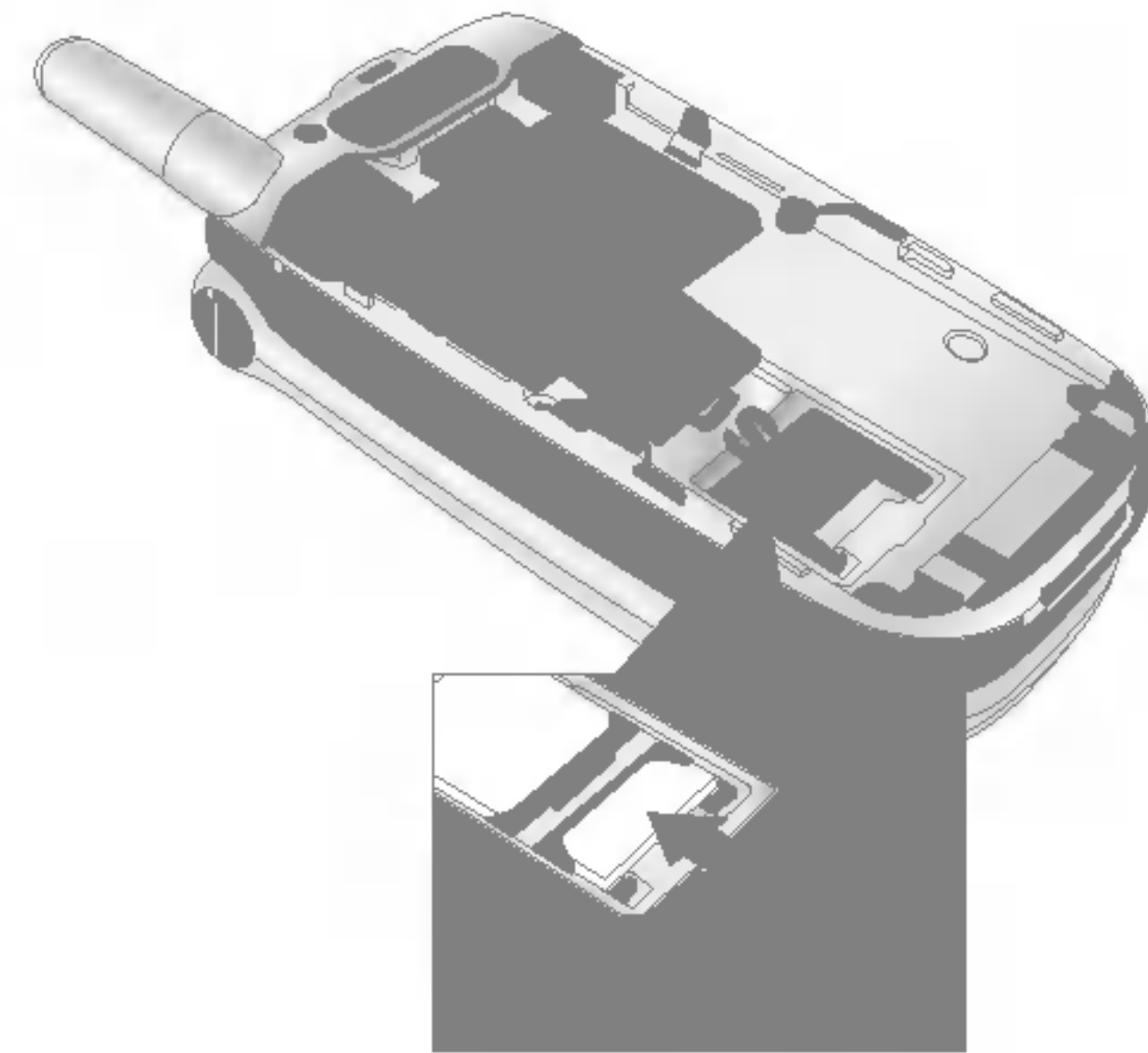

Notice

Before installing always make sure that the phone is switched off and remove the battery. The metal contact of the USIM card can be easily damaged by scratches. Pay special attention to the USIM card while handling and installing. Follow the instructions supplied with the USIM card.

Getting to know your LG U8360

Familiarise yourself with its features



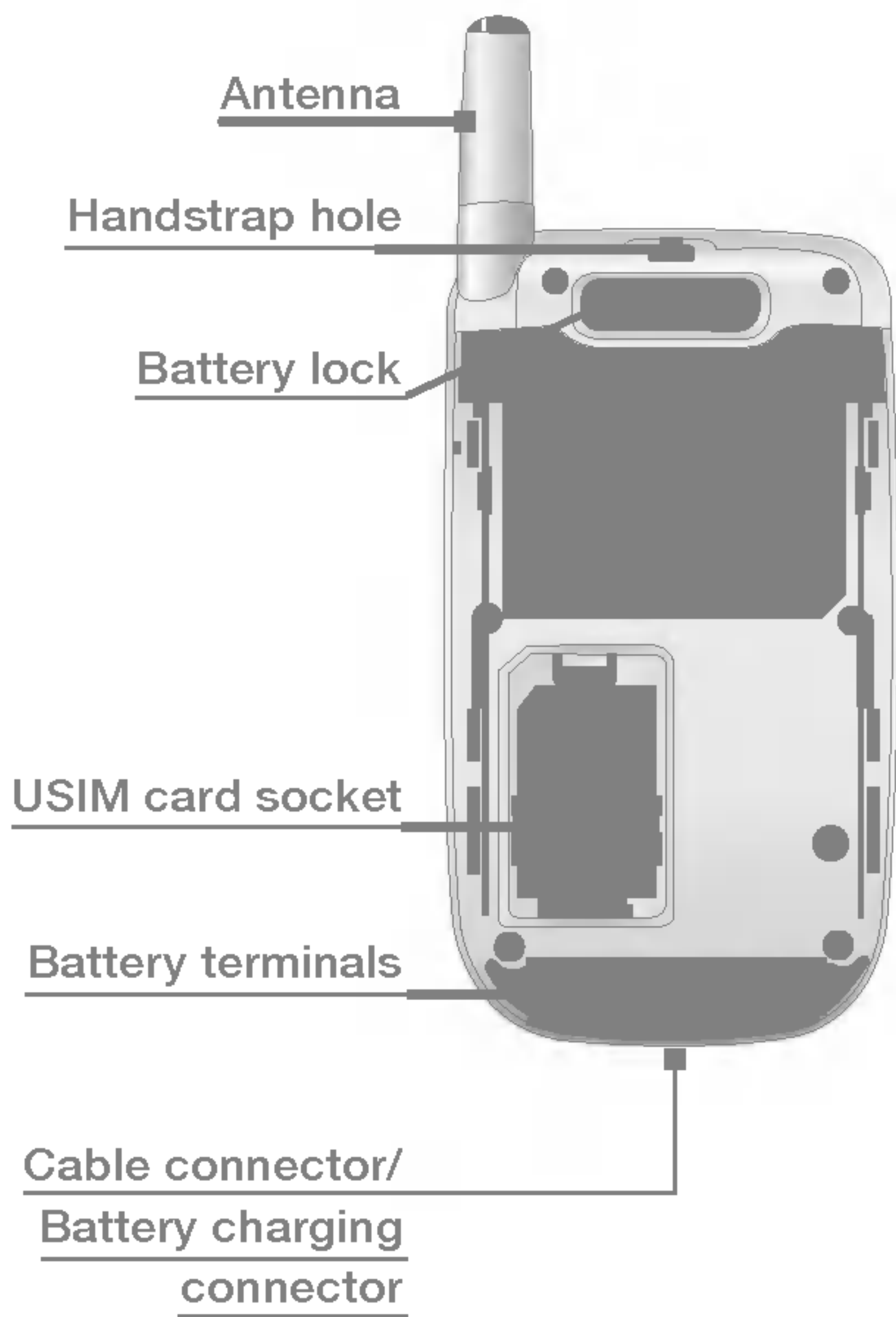

Getting to know your LG U8360

Your handset's home screen

Your handset's home screen is divided into three basic displays: the icon indicator bar; a central window that includes the home screen; and the prompt bar. Each of these is described below:



The icon indicator bar

The icon indicator bar shows what operations are taking place and reminds you of battery and signal strength. This appears through all activities. The table below gives a brief explanation of the icons and their function.

The home screen

The central window of your start screen displays an image of your choice, when in use, this screen will display all of your functions and services.



















The prompt bar

The prompt bar displays in the soft boxes. These are activated by pressing the appropriate soft key under each one.

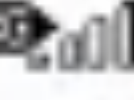
Display Information

The table below describes various display indicators or icons that appear on the phone's display screen.

On-Screen Icons

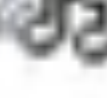
	Battery level - indicates the amount of power in your battery. The greater the amount of solid colour the greater the power.		No-service area - indicates you are in the no-service area.
	Call diverting - indicates call divert option has been selected.		Roaming service - indicates that you are using a roaming service.
	Call reject - indicates call reject option has been selected.		ExpressLink message - indicates that there is new ExpressLink content.
	Voice message - indicates when you have a new voice message.		Indicates the Bluetooth connection is activated.
	Text - indicates when you have a new text message.		Indicates when you have a new Bluetooth message.
	Multimedia - indicates when you have a new Multimedia message.		Alarm - indicates an Alarm.
	3G network - indicates whether you are in the 3 video service area.		Normal - indicates the General profile is activated
	When you leave the 3 video service area, your handset roams onto the voice & picture network or when abroad onto another network(2G/3G)		Silent - indicates the silent menu in Profile.
	2G network - indicates the strength of your handset's connection with a 2G network.		Vibrate only - indicates whether the vibrate function is on or off.
			Headset - indicates the headset menu in Profile.
			Outdoor - Indicates the loud profile is activated.

Getting to know your LG U8360

Your handset's keys and navigation



(1) The Menu key

This key takes you to the main menu from any screen.

(2) The navigation key

Use for quick access to phone functions.

(3) The OK key

The button in the centre of the Navigation key allows you to select objects on the screen. Once you have scrolled to your desired choice use the OK key to select it. This function can be used in the majority of screens.

(4) The Triangle key

This key is your one-touch access to Today on 3, a world of communications, information and entertainment.
(long press) Try to register on 3 network.

(5) The Send key

This key is used to make and answer voice calls.

(6) The End key (On/Off)

This key is used to end calls and close down applications.

(7) The Clear key

This key has two functions. It will take you back to your previous screen and when in a text entry screen, it acts as a delete key.

(8) The soft keys

The left and right soft keys activate the prompts that appear in the soft boxes directly above them. These prompts change according to the screen content.

(9) The Video call key

To make and answer a video call.

(10) The Back key

This key takes you back to the previous screen.

Function of keys when phone is idle

Side of handset Keys

Video/Camera key

(short press) Video recorder
(long press) Camera

(long press) Light

(only activates once flip is close)

Volume of key tone



Navigation key

- Up : Quick Menu
- Down: Search contacts
- Right : (short press) Messages menu
(long press) New message
- Left : (short press) Profiles popup window
(long press) Profile vibrate mode

Call history

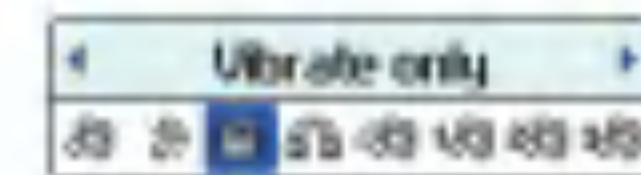

- BACK: Back to previous screen.
- C : In a text entry screen, it acts as a delete key.

Extra keys

- Video call: To make and view call history
- Triangle key: Access to Today on 3.
- Menu: (short press) Main menu (long press) Multitasking history



General Functions

Turning your handset on

Ensure that your USIM card is in your handset and the battery is charged.

Press the  key.

Enter the USIM PIN code that was supplied with your USIM card if PIN code setting is on.

After a few seconds you will be registered on the network.

Turning your handset off

Press and hold the  key until power is off.

There may be some delay while the handset powers down.

Do not re-power the handset during this time.

Access Codes

You can use the access codes described in this section to avoid unauthorized use of your phone. The access codes (except PUK and PUK2 codes) can be changed by using the **Change codes** feature [Menu 3.4.3].

PIN code (4 to 8 digits)

The PIN (Personal Identification Number) code protects your USIM card against unauthorized use. The PIN code is usually supplied with the USIM card. When the PIN Code Request is set to Enable, your phone will request the PIN code every time it is switched on. When the PIN Code Request is set to Disable, your phone connects to the network directly without the PIN code.

PIN2 code (4 to 8 digits)

The PIN2 code, supplied with some USIM cards, is required to access functions such as Fixed Dial Number. These functions are only available if supported by your USIM card.

PUK code (4 to 8 digits)

The PUK (PIN Unblocking Key) code is required to unlock a blocked PIN code. Contact 3 Customer Services for the code.

PUK2 code (4 to 8 digits)

The PUK2 code, is required to unlock a blocked PIN2 code. Contact 3 Customer Services.

Security code (4 to 8 digits)

The security code protects the unauthorized use of your phone. The default security code is set to '0000' and the security code is required to delete all phone entries and to restore the handset to factory setting.

Barring Password

The barring password is required when you use the call barring function. The password is obtained from the 3 Customer Services when you subscribe to this function.

Making and Answering calls

Ensure you tell the other party before recording a voice call.

Making and Answering a video call



You can make/answer a video call to a 3G video phone the other party must have a 3G video phone and be in a video service area.

To make/answer a video call, do the following.



1. Input the phone number using the keypad, or select the phone number from the calls made/received lists.

Note

To correct mistakes, press the  key briefly to delete the last number, or press and hold the  key to delete all numbers.

2. If you do not want to use the speakerphone, ensure you have the headset plugged in.





General Functions

Note

The video call may take some time to connect. Please be patient. The connection time will also depend on how quickly the other party answers the call. While the video call is connecting, you will see your own images; after the other party has answered, their image will be displayed on screen.

3. Adjust the camera position if necessary.
4. Press the end key to finish the call, or close the handset.

Making a voice/video call

1. Make sure your handset is powered on.
2. Enter the number including the full area code.
 - To delete a digit press the  key.
 - To delete all digits press and hold the  key.
3. Press the  key to make a voice call.
Press the  key to make a video call.
4. Press the  key to finish the call, or close the handset.



Note

To activate the speakerphone during a Voice call, you have to press and hold the  key for at least 2 secs.

Making a voice/video call from Contacts



It is easy to call anyone whose number you have stored in your Contacts.

Press the down navigation key to access contact list.

Scroll to your chosen contact and press the  key. To make a voice call press the  key.

To make a video call press the  key. Press the  key to finish the call.

Making International Calls

1. Press and hold the  key for the international prefix. The '+' character can be replaced with the international access code.
2. Enter the country code, area code, and the phone number.
3. Press the  key.



Adjusting the Volume

During a call, if you want to adjust the earpiece volume, use the side keys of the handset. In idle mode with the flip cover open, you can adjust the key volume using the side keys.

Answering a Call

When you receive a call, the phone rings and the flashing phone icon appears on the screen. If the caller can be identified, the caller's phone number (or name if stored in your Contacts) is displayed.

1. Open the flip and press the  key to answer an incoming call.

If the **Press any key** menu option has been set to  key, **Press any key** will answer a call except for the  key.

Notice

- To reject an incoming call, press and hold down the side key on the left side twice of the handset without opening the flip (See page 120). If the flip is open, press the  key or the right soft key twice.

- If the **Open flip** menu option ((Menu #.9.4) is simply by opening) is on , you can answer the call simply by opening the flip.

2. End the call by closing the handset or pressing the  key.

Notice

You can answer a call while using the Contacts or other menu features.

Signal Strength

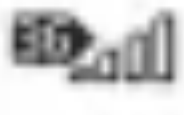
If you are inside a building, being near a window may give you better reception. You can see the strength of your signal by the signal indicator see the strength () on your handset's display screen.

Entering Text







You can enter alphanumeric characters using the keypad.

For example, storing names in the Contacts, writing a message, creating a personal greeting or scheduling events in the calendar all require entering text.

General Functions

Following text input methods are available in the handset.

Changing the Text Input Mode

1. When you are in a field that allows characters to be entered, you will notice the text input mode indicator in the upper right corner of the display.
2. Short pressing the  key cycles between  ,  ,  ,  and  .

Using the T9 Mode

The T9 predictive text input mode allows you to enter words easily with a minimum number of key presses. As you press each key, the handset begins to display the characters that it thinks you are typing based on a built-in dictionary. As new letters are added, the word changes to reflect the most likely candidate from the dictionary.

1. When you are in the T9 predictive text input mode, start entering a word by pressing keys  to  . Press one key per letter.

- The word changes as letters are typed - ignore what's on the screen until the word is typed completely.
- If the word is still incorrect after typing completely, press the  key once or more to cycle through the other word options.

Example

Press     to type Good

Press the  key to get Home

- If the desired word is missing from the word choices list, add it by using the ABC mode.
2. Enter the whole word before editing or deleting any keystrokes.
 3. Complete each word with a space by pressing the  key.

To delete letters, press the  key.



Press and hold down the  key to erase entire words.

Using the ABC Mode

Use the  to  keys to enter your text.

1. Press the key labeled with the required letter:

- Once for the first letter
- Twice for the second letter
- And so on

2. To insert a space, press the  key once.
To delete letters, press the  key. Press and hold down the  key to clear the display.



Using the 123 (Number) Mode

The 123 Mode enables you to enter numbers in a text message (a telephone number, for example).

Press the keys corresponding to the required digits before manually switching back to the appropriate text entry mode.

Using the Symbol Mode

The symbol mode enables you to enter various symbols or special characters.

To enter a symbol, press the  key. Use the navigation and numeric keys to select the desired symbol and press the  key.

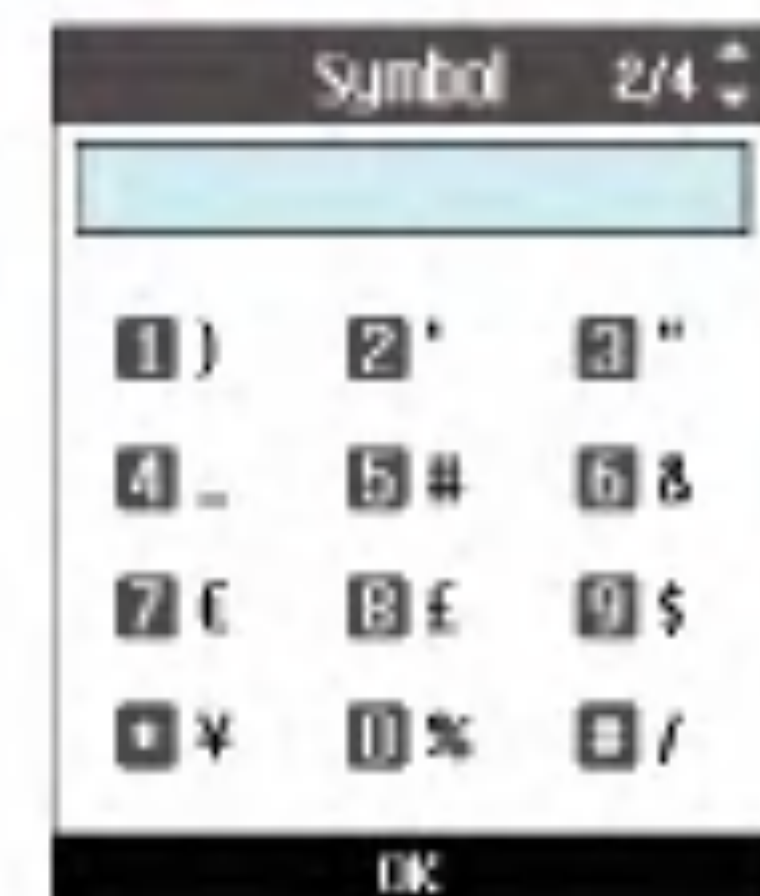

General Functions

Character chart

General text entry rules for use with the abc mode.

Use the keypad to enter letters, numbers, symbols, and other characters with the abc mode. Press the same key repeatedly to cycle through available characters.



If you do not press a key for 2 seconds, the character in the block cursor is accepted, and the cursor moves to the next position.

Notice

Refer to the table below for more information on the characters available using the keys.

	@:/.	@:/.
	@:/. 1 .,?!“1-()@/!:_	@:/. 1 .,?!“1-()@/!:_
2	abc2àáâãäåæç	ABC2ÀÁÂÃÄÅÆÇ
3	def3èéêë	DEF3ÈÉÊË
4	ghi4ìíîï	GHI4ÌÍÎÏ
5	jkl5£	JKL5£
6	mno6ñòóôõöøœ	MNO6ÑÒÓÔÕÖØŒ
7	pqrs7ß\$	PQRS7ß\$
8	tuv8ùúûü	TUV8ÙÚÛÜ
9	wxyz9	WXYZ9
0	space0	space0

Menu tree

Your handset offers a set of functions that allow you to use and customise the handset. These functions are arranged in menus and sub-menus, accessed via the two soft keys marked left soft key  and right soft key .

Each menu and sub-menu allows you to view and alter the settings of a particular function. The roles of the soft keys vary according to the applications and services; the label on the bottom line of the display just above each key indicates its current role.



Press the left soft key to access the available My stuff.

Press the right soft key to access the available Planet 3.

Menu tree

1. Screen (see page 40)

1.1 Screen theme

- 1.1.1 Home screen
- 1.1.2 Outgoing call
- 1.1.3 Switch on
- 1.1.4 Switch off

1.2 Front screen theme

- 1.2.1 Home screen
- 1.2.2 Outgoing call

1.3 Menu style

1.4 Font

1.5 Backlight

1.6 Handset theme

- 1.6.1 Normal
- 1.6.2 Disco

1.7 Greeting message

2. Profiles (see page 44)

2.1 Normal

2.2 Silent

2.3 Vibrate only

2.4 Headset

2.5 Outdoor

2.6 Customsied 1

2.7 Customsied 2

2.8 Customsied 3

3. Settings (see page 48)

3.1 Date & Time

- 3.1.1 Time
- 3.1.2 Date
- 3.1.3 Auto update date/time
- 3.1.4 Daylight saving

3.2 Network

- 3.2.1 Network seletion
- 3.2.2 Preferred list

3.3 Access points

3.4 Security

- 3.4.1 PIN code request
- 3.4.2 Handset lock
- 3.4.3 Change codes

3.5 Language

3.6 Memory status

3.7 Handset information

3.8 Reset settings

- 3.8.1 Clear memory
- 3.8.2 Default setting

4. Browser (see page 54)

4.1 Home

4.2 Bookmarks

4.3 Saved pages

4.4 Go to URL

4.4.1 Enter address

4.4.2 Recent pages

4.5 Security

4.5.1 Certificates

4.5.2 Session clear

4.6 Settings

4.6.1 Profiles

4.6.2 Character encoding

4.6.3 Scrolling control

4.6.4 Show Image

4.6.5 Cache

4.6.6 Cookies

4.6.7 Clear cache

4.6.8 Clear cookie

5. Messages (see page 62)

5.1 New message

5.1.1 Text message

5.1.2 Multimedia message

5.1.3 Email

5.2 Inbox

5.3 Mailbox

5.4 Drafts

5.5 Outbox

5.6 Sent items

5.7 Templates

5.8 Settings

5.8.1 Text message

5.8.2 Multimedia message

5.8.3 Email

5.8.4 Videomail

5.8.5 Voicemail

5.8.6 ExpressLink

5.8.7 Info. Service

6. My stuff (see page 76)

6.1 Images

6.2 Videos

6.3 Sounds

6.4 Applications

6.5 External memory

6.6 Play lists

7. Multimedia (see page 84)

7.1 Video camera

7.2 Camera

7.3 Voice recorder

7.4 Settings

7.4.1 Video camera

7.4.2 Camera

7.4.3 Voice recorder

7.4.4 Memory status

Menu tree

8. Contacts (see page 88)

- 8.1 Add new
- 8.2 Search
- 8.3 Speed dials
- 8.4 Groups
- 8.5 Service dial numbers
- 8.6 Own number
- 8.7 Settings
 - 8.7.1 Display data
 - 8.7.2 Show image/avatar
 - 8.7.3 Copy all
 - 8.7.4 Move all
 - 8.7.5 Clear contacts

9. Applications (see page 92)

- 9.1 My games & apps
- 9.2 Download games & apps
- 9.3 Settings

***. Organiser (see page 96)**

- *.1 Calendar
- *.2 To do
- *.3 Memo
- *.4 Secret memo
- *.5 Date finder
- *.6 Dateulator
- *.7 Settings
 - *.7.1 Calendar
 - *.7.2 Memory info.
 - *.7.3 Clear all

0. Tools (see page 104)

- 0.1 Quick menu
- 0.2 Alarm clock
- 0.3 Connectivity
 - 0.3.1 Buletooth
 - 0.3.2 Server synchronisation
- 0.4 Calculator
- 0.5 World time
- 0.6 Unit converter

#. Calling (see page 114)

#.1 Video calls

#.2 Call history

#.2.1 Missed calls

#.2.2 Received calls

#.2.3 Dialed calls

#.2.4 All calls

#.3 Call duration

#.4 Call costs

#.5 Call divert

#.5.1 Voice calls

#.5.2 Video calls

#.5.3 All fax calls

#.6 Call barring

#.6.1 Voice calls

#.6.2 Video calls

#.6.3 Deactivate all

#.7 Fixed dial numbers

#.8 Call waiting

#.8.1 Activate

#.8.2 Deactivate

#.8.3 View status

#.9 Settings

#.9.1 Call reject

#.9.2 Send my number

#.9.3 Auto redial

#.9.4 Answer mode

#.9.5 Minute minder

1.Screen

Screen

In this menu, you can configure screen display options including Screen settings and themes.

Screen theme

Home screen

You can select a wallpaper (animated or static) to display in idle mode.

Outgoing call

You can select an image to display when dialing a call.

The configuration is applied to both voice and video calls.

Switch on

You can select an image to display when turning on the handset.

Switch Off

You can select an image to display when turning off the handset.

Front screen theme

You can configure the background of the front screen by themes.

Home screen

You can select a wallpaper to display in idle mode.

Outgoing call

You can select an image to display when dialing a call.

The configuration is applied to both voice and video calls.

Menu style

You can configure the menu style to **Grid style** or **Arc style**.

Font

You can configure the font size and colour of the numbers which appear in the home screen when you make a call.

Backlight

Use this to select whether or not the phone uses the backlight.

Main screen duration	Off 5 seconds 10 seconds 15 seconds 30 seconds 1 minute 2 minutes 3 minutes On
Front screen duration	Off 5 seconds 10 seconds 15 seconds 30 seconds 1 minute 2 minutes 3 minutes
Keypad duration	Off 5 seconds 10 seconds 15 seconds 20 seconds On

Screen

Handset theme

You can change the Wallpaper of the menu, soft key area, title bar area, and cursor by changing the menu theme.

Greeting message

Set a message that is displayed when the handset is turned on.



2.Profiles

Profiles

You can configure Voice/Video ringtone, key tone, flip tone, sound effects, switch on, switch off, and volume. The ringtone type supports MP3, .3gp, AAC, MIDI, WAV and AMR. Supported profiles are Normal, Silent, Vibrate only, Headset, Outdoor, Customised 1, Customised 2 and Customised 3 profile. Select a desired profile, and press the  key to activate the profile. When the cursor is moved to a profile, the corresponding menu appears on the soft bar. If you select View/Edit menu, you can view the settings of the profile, or can edit settings of the profile.

Profiles menu have the submenus as shown below.

■ Alert by

This option determines the incoming call and the message notification mode. You can select from Ring, Vibration, Silent, Ring & vibration Ring after vibration and Max ring & Vibration.

■ Voice ringtone

This option determines the Voice ringtone for incoming call notification.



■ Video ringtone

This option determines the Video ringtone for incoming call notification.

■ Volume

This option determines the ringtone volume for incoming call notification.

■ Message alert

This option determines the message alert that sounds when a message has arrived. You can select one of None, Once, Every 1 minute, Every 2 minutes, Every 5 minutes, and Every 10 minutes mode.

■ Message tone

This option determines the message tone that sounds when a new message has arrived.

■ Key tone

This option determines the key tone that is sounded when a key is pressed.

■ Key tone volume

This option determines the volume of the key tone.

■ Flip tone

This menu option allows you to select a melody that the phone sounds when it is flip open and closed.

■ Confirmation tone

This option determines if warning alerts are on or off.

■ Switch on sound

This option determines the switch on effect that is sounded when the handset is turned on.

■ Switch on file

This option allows you to select a melody that is sounded when the the phone is switched on.

■ Switch off sound

This option determines the switch off effect that is sounded when the handset is turned off.

■ Switch off file

This option allows you to select a melody that is sounded when the the phone is switched off.



3.Settings

Settings



Date & Time

You can change the format of the time and date display as well as the actual time and date using the Time settings menu.

Time

1. Select the Time item from the handset settings list and then press the  key.
2. Input the current time using the numeric keys.
3. Select the time format using the left and right navigation keys.
4. Press the  key to save the time.

Date

1. Select the Date item from the handset settings list, and then press the  key.
2. Input the date using the numeric keys.
3. Select the date format using the left and right navigation keys.
4. Press the  key to save the date.

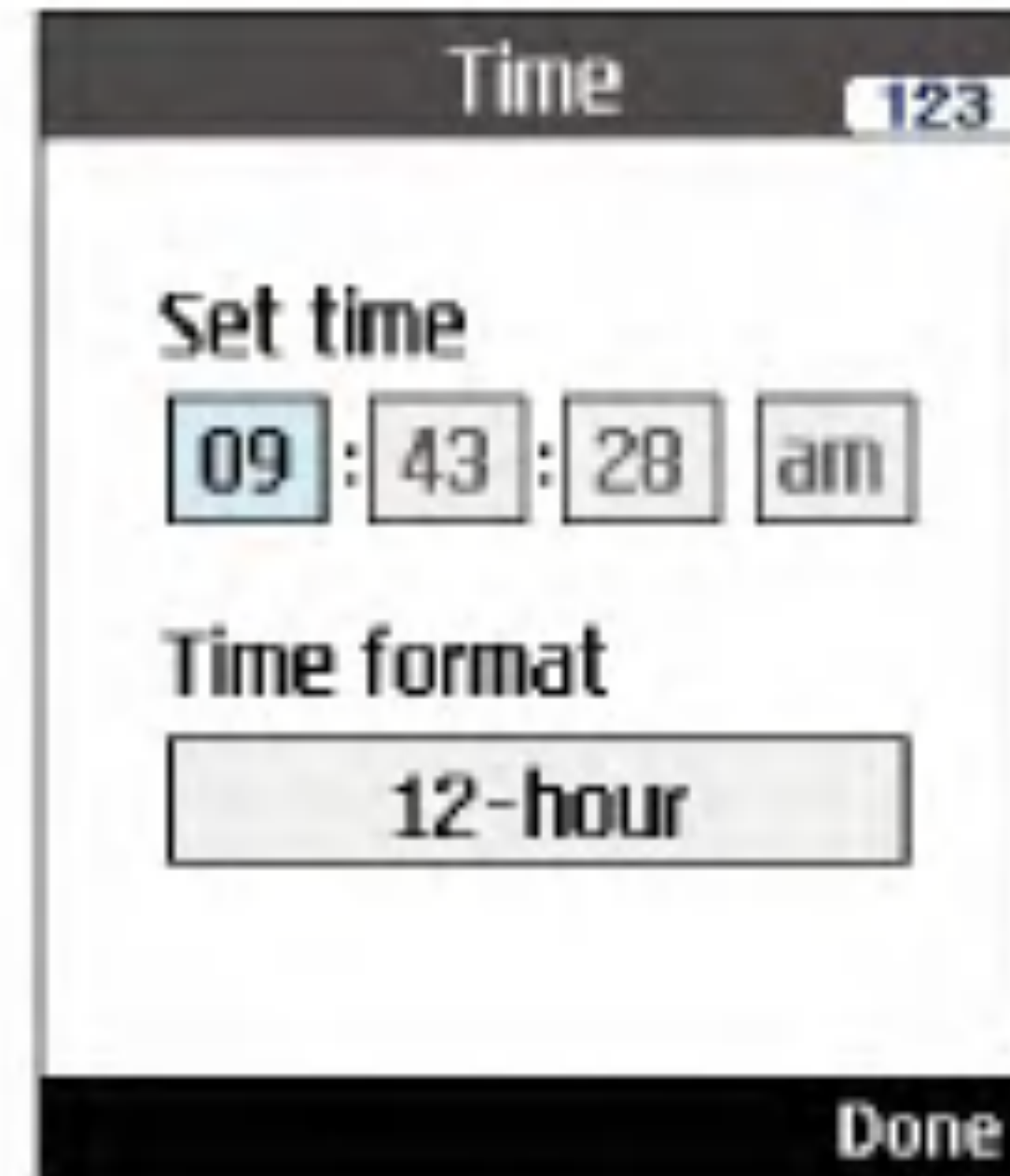

Note

Please make sure that you set the exact date and time to ensure that all 3 services operate correctly.

Auto update date/time

When Auto Update is configured to On, the time and date are automatically updated according to the current time zone. If Confirm first is selected, time and date update are confirmed before the automatic update.

Daylight saving

This function enables Summer time. Configuring Daylight saving to On immediately applies summer time (For example, if the current time is 04:53, summer time is then 05:53).

Network

Network selection

■ Automatic

This function automatically searches for the network and registers the handset to the network.

■ Manual

This function enables you to search the network list and specify which network to attempt registration with.

Preferred list

You can select preferred lists to display it saved in the current USIM card and can edit the current preferred list.

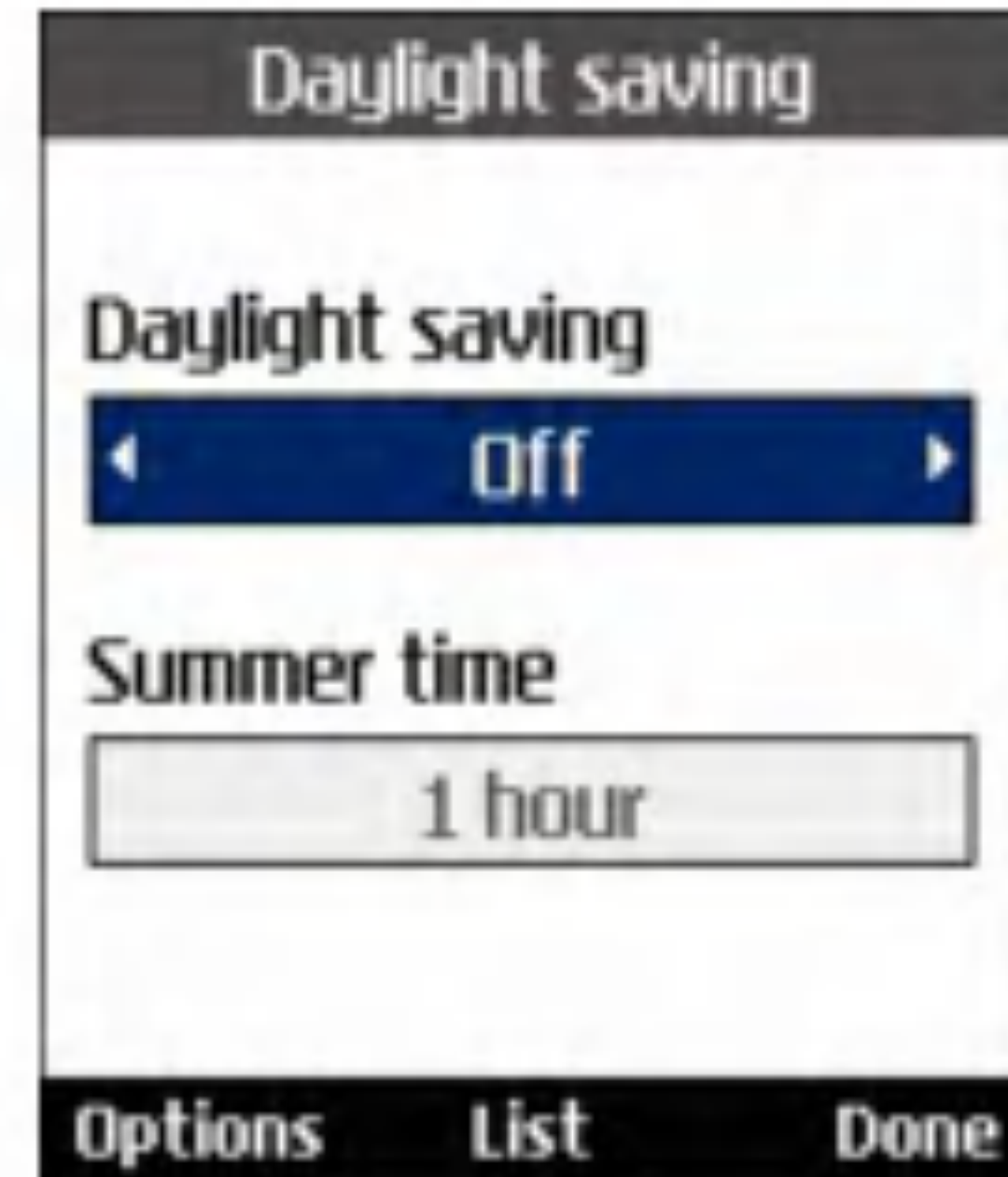

Access points

This menu shows the Access Point List. Select the  key [Edit]. Access Point has the following items.

- Connection title: Profile Name
- Bearer: UMTS/CSD/GPRS
- Username: User name
- Password: Password
- APN: APN information of the service provider

To modify these settings please call 3 Customer Service.

Settings



Security

You can set a PIN code. When it is activated, a window asking you to enter the PIN code appears when you turn on the handset so as to prevent unauthorized use of the handset.

PIN code request

You can activate a PIN (Personal Identification Numeric).

You can check the current status of configuration from the status bar.

1. Select PIN code request from the security menu and press the  key.
2. Configure this item to On or Off. If it is On, a PIN code will be required whenever the handset is turned on.
3. Input the current PIN code and press the  key.
4. Entering an incorrect PIN code 3 times in the PIN code input window invalidates the PIN code. In this case, the PUK code must be entered in order to reset the PIN code.

5. The maximum number of attempts at PUK code input permitted is 10. Entering an incorrect PUK code 10 times will restrict use of the handset. In this case, ask 3 Customer Service to unlock your handset.

Press the Back key in the PIN code input window to return to the previous step.

Handset lock

You can use security code to avoid unauthorized use of your handset.

When you switch on your handset, your handset will request security code always if you set phone lock to “Power on”.

You can select the menu from **When switching on, If USIM changed, Lock now, and None.**

Change codes



You can change PIN, PIN2 and the security code.

Note

If you change the code and then forget it you will need to contact your place of purchase to unlock it or solve this problem.

■ PIN/PIN 2 code

This menu allows you to change the PIN or PIN2 code.

1. Select Change codes from the Security Settings List and press the  key.
2. Select PIN or PIN2 Code and press the  key.
3. Input the current PIN or PIN2 code, and then a new PIN or PIN2 code. Entering an incorrect PIN code 3 times invalidates the PIN code. In this case, you will need to enter the PUK or PUK2 code in order to reset the PIN code.
4. Entering an incorrect PUK code 10 times will restrict use of the handset. In this case, ask 3 Customer Service to unlock your phone.

■ Security code

This menu allows you to change the handset password. The maximum allowed numeric of attempts of security code input is not limited like PIN and PIN2.



Language

This function allows you to set the language used in the handset.

Memory status

This menu is used to view the memory use of the phone and USIM card. You can obtain information about the amount of memory used by the contacts, the calendar, to do, memos, secret memos and text message and multimedia messages.

Settings

Common memory

This function shows the status of the user memory of the handset.

Reserved memory

This function shows the available memory for the user.

USIM memory

This function shows the status of the USIM card user memory.

External Memory

This function shows the status of the external memory card.

Handset information

This menu is used to view phone number, model number and software version information.

Reset settings

This function allows you to restore factory settings.

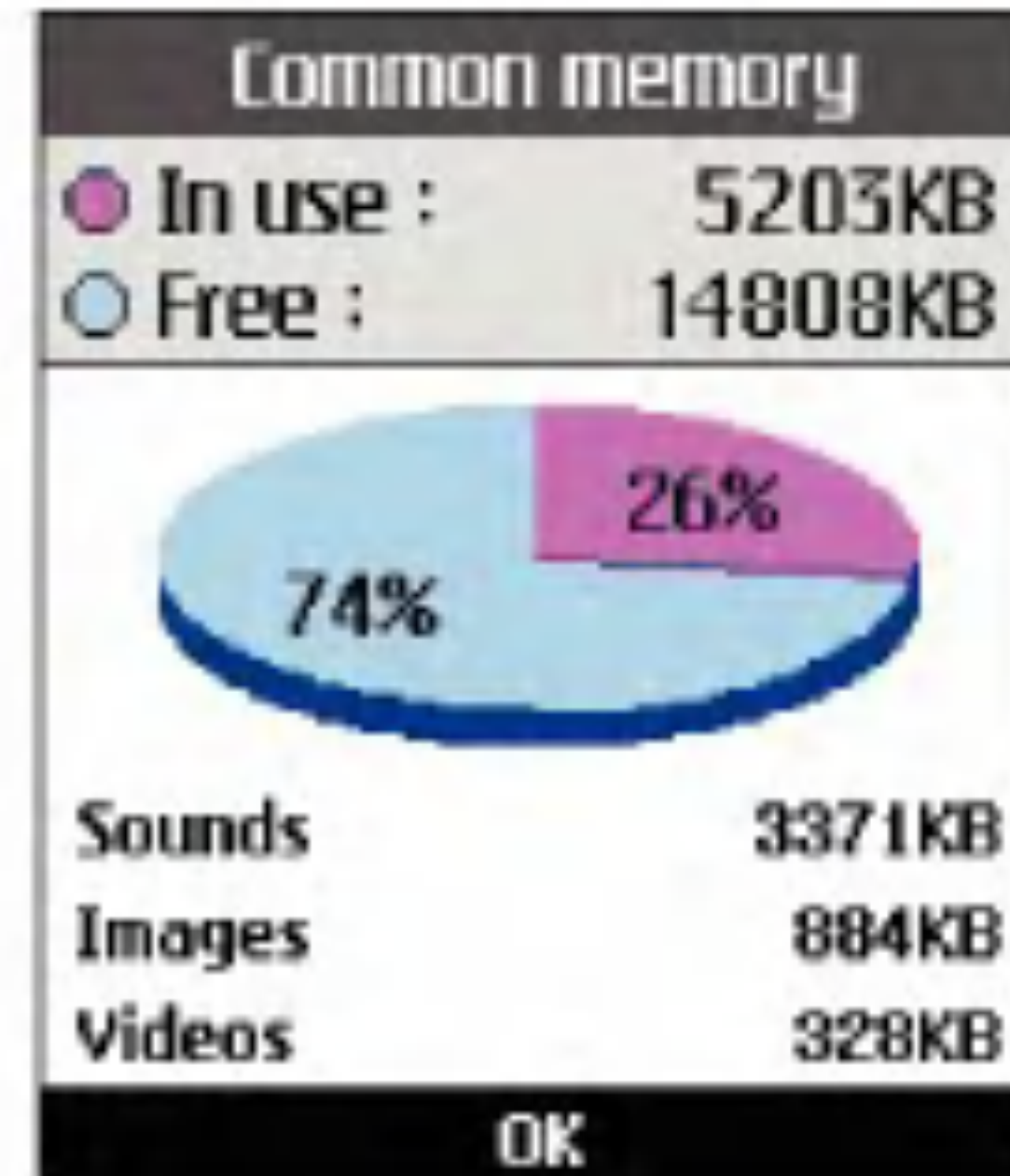

Undertaking a reset will not remove any user content.

4. Browser

Browser

3 brings you a whole world of communications, information and entertainment services.

You can ask for directions within major cities, get the latest news, keep up to date with Premier League action and much, much more.

The browser is available in the 3G coverage area.



To launch the browser in standby mode, press the  key.

Home

Select Home in the Internet Menu and then press the  key.

If you want to reload current page, press the right soft key [Reload].

The following options are available. Press the left soft key [Options].

-  Home: Moves to the initial homepage.
-  Reload: Loads the current page again.
-  Bookmark: You can add or save the current page to the Bookmark or view the list saved under Bookmark.

-  Settings: You can set the Browser related things such as Clear cache, Session info., Clear cookies, etc.

-  Back: Moves to the previous page.

-  Forward: Moves to the previous page.

The following example shows the functionality of browser menu 'Forward'.

1. Navigation Page A → Page B → Page C → Page D
 2. On Page D, select a menu 'Back', it will place a user in Page C.
 3. On Page C, if select a menu 'Back', move to Page B. Else if select a menu 'Forward', move to Page D again.
-  Go to URL: Connect to the specific URL after editing.

Bookmarks

This function allows you to store and edit frequently accessed sites.

The following options are available. Press the left soft key [Options].

Connect

Allows you to access the selected site.

Send

Selected bookmark URL can be sent via text message or multimedia message.

Add new

Adds a new site to the bookmarks list.

Edit

You can edit and save the name and address of the selected bookmark.

Mark/Unmark

Allows you to mark or unmark the selected site.



Delete

Delete the selected bookmark.

Saved pages

Saves the page on display as an off-line file. A maximum of 20 pages can be saved.

Go to URL

Connect to the specific URL after editing.

Browser

Security

■ Certificates

A list of the available certificates is shown.

■ Session clear

Allows you to close the security connection.

Settings

Profiles

Select the profiles by press  key to launch browser.

Character encoding

Select the character set one of the following list : Automatic, English(ASCII), English(ISO), English(LATIN), Unicode(UCS2 BE), Unicode(UCS2 LE), Unicode(UCS2 Auto), Unicode(UTF-16 BE), Unicode(UTF-16 LE), Unicode(UTF-16 Auto), Unicode(UTF-8).

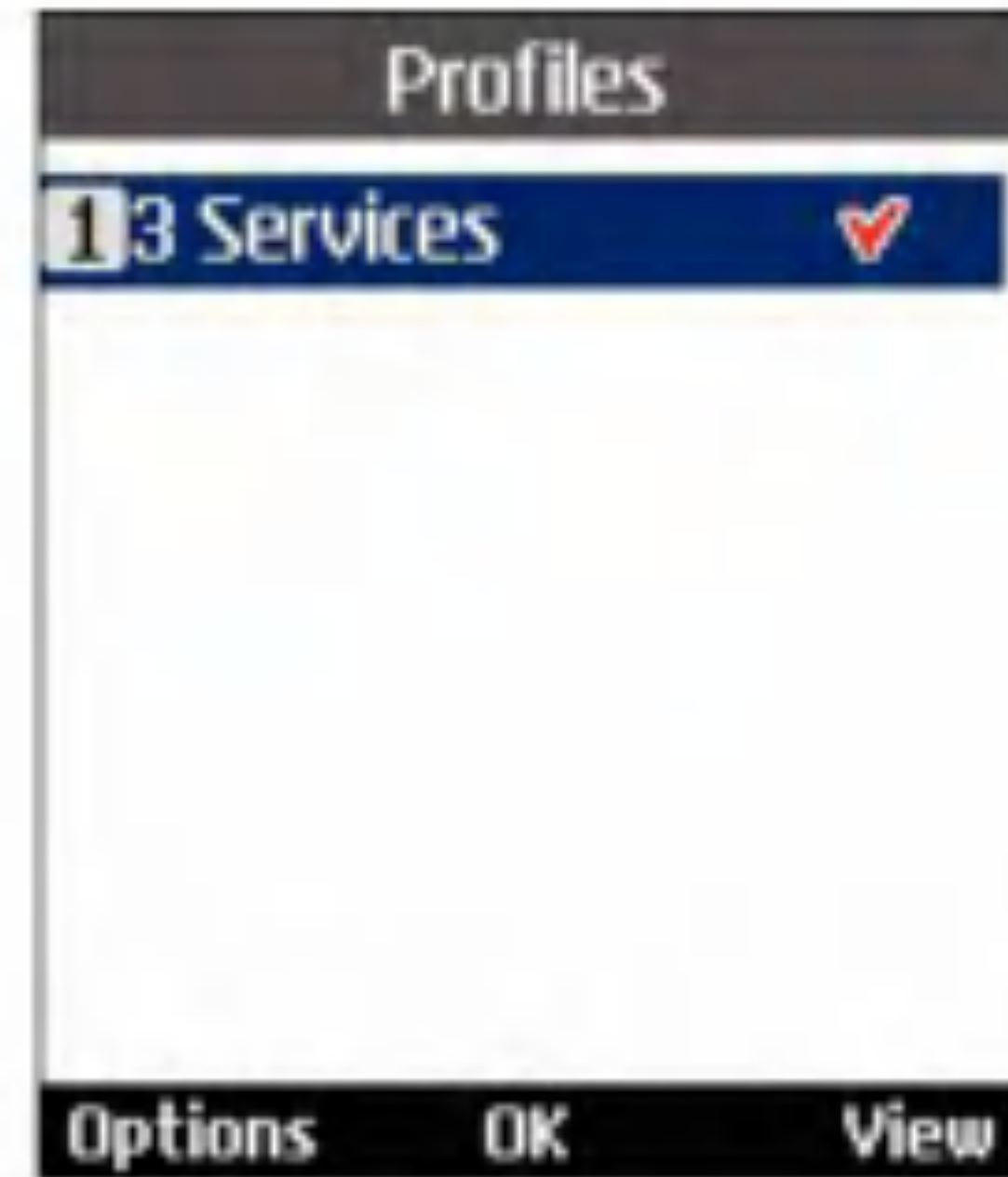

Scrolling control

Allows you to determine the scroll speed and select from **1 line**, **2 lines** and **3 lines**.

Show Image

Choose if you want to view pictures when you are browsing.

Note

If you set to activate this function, the WAP page have images may be delayed until the transmission is completed. To fast transmission, the Show image should be deactivated.

Cache

Choose if you want to store the WAP (network) pages that you have accessed. If you set to activate this function, you can search the accessed WAP page quickly in cache memory.

Cookies

Choose if you want to store cookies received from the WAP site. If you set to deactivate this function, cookies never come in your phone.

Clear cache

Deletes the data saved in the cache memory.

Clear cookie

Deletes the data saved in the cookie memory.

Live Streaming

This application plays streaming in live. To have a pleasure time with this, you must launch browser first, access to entertainment services and find live streaming menu.

Press streaming icon to enjoy yourself a world of live streaming.



When you press streaming icon, the mobile terminal shows a live streaming automatically

VCR Control

If the streaming is in live, the mobile terminal shows VCR control skin with live bar.

1.  : Play and Pause alternately.
2. mute/unmute Key: mute/unmute the sound temporarily.

Browser

OPTION

Press the left soft key [Options] to display the following popup menu items.

1. Mute/unmute : mute/unmute the sound temporally
2. Video Size: Normal/Landscape (for normal video) or Normal/Zoom/Landscape (for small size video)
3. Content Info : Shows information about the current content provided by streaming server

Normal Streaming

Normal streaming is very similar to live streaming. To enjoy with this , you must launch browser, access to entertainment services and select the normal streaming menu like as news, stock, music, weather etc.

VCR Control

If the streaming is not in live, the mobile terminal shows VCR control skin with current play time



1.  : Play and Pause alternately.
2. Navigation left/right key: You can go forward/back with this key more rapidly. The following example shows the functionality of streaming menu “FF/REW”
 - press FF/REW Key during playing streaming, the mobile terminal paused video.
 - press more FF/REW Key , the mobile terminal display the new time and progress bar immediately. (user can select new time with FF/REW Key)
 - if there is no press Key more, then the mobile terminal start streaming with new time.



3. mute/unmute Key: mute/unmute the sound temporarily.

The **OPTION** is same as live streaming.



5.Messages



Messages

New message

Text message

Press the Message shortcut key to display Messages menu, select **New message** and then select **Text message**.

You can write and edit a single text message up to 160 characters. You can write and edit up to 10 concatenated messages.

1. Press the left soft key [Options]/ [Search contacts] or use the  key [Contacts] to specify the recipient from Contacts.
2. When you input content, a new window allowing you to input content appears. By using the left soft key [Options]/[Insert], you can input emoticons, templates, and phone numbers through the Contacts. By using the  key on the bottom, you can input various symbols.
3. When the message has been sent, it will be saved in the Sent items automatically. If the message has not been sent, it will stay in the Outbox with fail status.





Multimedia message

Creating a Multimedia message

Select Messages from the top menu or pressing the Message shortcut key displays the message menu. In the menu, select New message, and then select Multimedia message and create a Multimedia message.

You can simply send picture with a Multimedia message attaching the picture from your album or directly from the multimedia menu.



Multimedia message

1. You can create a Multimedia message.
2. Select **Multimedia message** from the **New message** menu and then press the  key.
3. You can edit a Multimedia message field using the Down navigation Key.
4. Move the highlight to the **To** field, and input the recipient of the message. You can specify the recipient by either phone number or Email address. You can search the Contacts by pressing the left soft key [Options] or the  key [Contacts]. When a recipient has been specified, another field appears where you can add more recipients.
5. Move the highlight to the title field, and write a title. You can select and input a template or emoticon by pressing the left soft key [Options].
6. You can add, delete, or edit each slide by moving the highlight to the text field.
7. You can save the message in the Drafts by using the left soft key [Options] while creating a message.
8. You can preview the message by using the left soft key [Options] while creating a message.
9. You can send the message by selecting the right soft key [Send].
10. You can select the following functions using the left soft key [Options].
 - **Insert:** You can insert slide, image, video, audio, template, the name or phone number saved in the contacts.
 - **Send:** Sends the created Multimedia message at the time you wanted.
 - **Save as draft:** Saves the created Multimedia message to Drafts
 - **Preview:** Shows the created Multimedia message before sending it
 - **View attachment:** Views the attachment file list.
 - **Slide duration:** Changes the slide duration of each slide.
 - **Remove:** Removes attachment file or slide in the selected slide
 - **Goto:** Directly moves to the chosen slide.

Messages

- Dictionary: Selects dictionary mode.
- Add to dictionary: Adds the writing string in dictionary



Viewing Multimedia messages in the Preview and Drafts

1. You can preview a created Multimedia message.
2. If the message is too long to be displayed on screen, you can scroll the contents of the message by using the up and down navigation key.
3. Press the  key to pause playback of the message, and press the  key to resume playing the message.
4. If an audio or video file is attached to a Multimedia message, press the right soft key [Mute] to cancel the unmute function.

Viewing Multimedia messages in the Inbox and Sent items

1. Select a Multimedia message to view its contents.



2. If the message is too long to be displayed on a screen, you can scroll the contents of the message by using the up and down navigation key.
3. Press the  key to pause playback of the message, and press the  key to resume playing the message.
4. If an audio or video file is attached to a Multimedia message, press the right soft key [Mute] to activate the mute function. Press the right soft key [Mute] to cancel the unmute function.
When the multimedia message includes URL, you can try to connect the site. If the slide

includes URL, you can connect the URL by long press  key.

On the other hand, when you try to press the up or down navigation key, the slide show is paused automatically, and the right soft key menu option changes to "Link" if a URL is included in the slide. You can connect to the URL for browsing, downloading, and streaming.

5. Move to a desired message by using the left and right navigation keys.

6. Press the  key to reply to the message.

7. You can select the following functions using the left soft key [Options].

- **Pause/Play:** Pauses/Plays the selected message.
- **Reply:** Creates reply to the selected message.
- **Forward:** Forwards the selected message.
- **Save address:** Saves the telephone number to Contacts.
- **Save attachment:** Saves the attachment file list.
- **New message:** Creates a new message.

- **Use:** Extracts the phone number, Email address or web address included in the text of the message.
- **Delete:** Deletes the selected message.
- **Mute/Unmute:** During playback of a Multimedia Message that includes audio/video, the mute/unmute option is available.
- **Go to header page:** Displays information about the selected message.

Email

To send an email, you should first set up an email account.

Message edit

1. Select **Email** from the New Message menu.
2. You can input up to 20 addresses in the To, Cc fields and up to 10 addresses in the Bcc field.

Tip

To input @, select the  key [Symbol], and then press 9 numeric key pad to input or press video call key.

Messages

3. Input the title of the mail to be sent in the Subject field.
4. Input the content of the mail to be sent in the Message field.
5. Specify up to 4 files to attach in the Attach field.
6. When you have finished writing a message, press the  key. You can send the message to outbox for Background sending.

Inbox

1. You can view saved messages. Select a message and then press the  key to view the message.
2. You can view the previous or next message by using the left and right navigation keys.
3. To view a Multimedia message, select **Retrieve** in the message view screen. The message will begin downloading and will be displayed when it is finished.
4. You can use the following functions by using the left soft key [Options].
 - **Reply:** Creates reply to the selected message.



- **Forward:** Forwards a selected message.
- **View:** Views a selected message.
- **New message:** Creates a new message.
- **Save address:** Saves the sender's address to the contacts.
- **Mark/Unmark:** Marks or unmarks the selected message.
- **Delete:** Deletes a selected message.
- **Copy:** Copies a selected message.
- **Move:** Moves a selected message.
- **Message Info.:** Displays information about the selected message.

Viewing Bluetooth messages in the Inbox and the message popup window

1. You can view vCalendar, vCard, Image and play audio/video messages received by bluetooth.
2. You can view saved bluetooth messages. Select a bluetooth message and then press OK key in the inbox to view it.
3. You can view the most recently recieved bluetooth message directly. Select Yes in the bluetooth message alert popup to view most recently recieved bluetooth message.
4. You can view the previous or next message in the inbox by using the left and right navigation keys, if you are viewing bluetooth message via inbox.
5. You cannot view the previous or next message, if you are viewing the most recent bluetooth message via bluetooth message alert popup.
6. You can use the Up and Down key to scroll up and scroll down to view message content that are beyond visible area.
7. You can use View key to view full screen image.
8. You can use Play key to play audio /video files.
9. You can use the following functions by using the left soft key [Options].
 - **Copy to calendar/contacts:** You can copy vCalendar/vCard messages to your calendar/phonebook.
 - **Save attachment:** You can save Images, audio and videos files to the phone for further use.
 - **New message:** You can write a new Text/Multimedia/ Email message.
 - **Forward:** You can forward bluetooth vCalendar/vCard messages via SMS/ Email.
 - **Delete:** You can delete the bluetooth message that you are currently viewing.

Messages

Mailbox

1. Select Mailbox.
2. Select 3mail to retrieve messages from the Server List.
3. To retrieve new messages in the Mail Header screen, select Retrieve to retrieve the new Mail Header List.
4. Select your desired message from the retrieved mail headers to retrieve the mail contents from the server.

You can use the following functions by using the left soft key [Options].

- **Reply:** You can reply to a selected message.
- **Forward:** Forwards a selected message.
- **Save address:** Saves the sender's address to the contacts.
- **New message:** You can write a new message via SMS, MMS and Email.
- **Use**
 - Number: Extracts the phone number included in the text of the message.



- Email address: View up to 10 email addresses contained in the text of the message. You can send a message or save as a contact by selected number.
- Web address: View up to 10 URLs contained in the text of the message. You can connect to the URL or save it as a bookmark.
- **View attachment:** Shows the attachment file list.
- **View to address:** Shows information in To/Cc/Bcc filed.
- **Delete:** Deletes a selected message.

- **Message info.:** Displays information about the selected message.

Drafts

1. You can edit saved messages. Select a message and then press the  key to edit the message.
2. You can use the following functions by using the left soft key [Options].

- **Edit:** You can edit a selected message.
- **Send:** You can send a selected message.
- **New message:** You can write a new message.
- **Mark/Unmark:** You can mark or unmark the selected message.
- **Delete:** You can delete a selected message.
- **Message info.:** Displays information about the selected message.

Outbox - messages waiting to be sent

Outbox is a temporary storage place for messages waiting to be sent. When you press the Send, the message moves to the Outbox and from there the message is sent. If the message fails to be sent from the Outbox, another attempt will be made. After two attempts the message will no longer be sent automatically. In order to send the message that has failed twice, you must press the Send from the Options menu.

Failed : The maximum number of sending attempts has been reached. Sending has failed. If you were trying to send a text message, open the message and check that the Sending options are correct.

Sent items

1. You can view sent messages. Select a message and then press the  key to view the message.
2. You can view the previous or next message by using the left and right navigation keys.
3. You can use the following functions by using the left soft key [Options].

Messages

- **Forward:** You can forward a selected message.
- **View:** You can view a selected message.
- **Edit:** You can edit a selected message.
- **New message:** You can write a new message.
- **Save address:** You can save the sender's address to the contacts.
- **Mark/Unmark:** You can mark or unmark the selected message.
- **Delete:** You can delete a selected message.
- **Message Info.:** Displays information about the selected message.

Templates

You can add, edit, and delete frequently-used phrases.

Settings

Text message

Delivery report

Allows you to activate or deactivate the report function. When this function is activated, the network informs you whether or not your message has been delivered.

Validity period

Allows you to set the length of time for which your text messages will be stored at the Text message centre while attempts are made to deliver them to the recipient.

Text message centre

The number of the Text message gateway is pre-loaded in your 3 handset and you should not change this. If you delete or change this by mistake contact 3 Customer Services for support.

Multimedia message

Select Multimedia message from the Settings menu to configure Multimedia message related options.

Delivery report

This menu allows you to determine whether to request a delivery confirmation mail to a recipient, and whether to allow sending delivery confirmation mail to a sender.

- Request report: Determines whether to request a delivery confirmation mail for a Multimedia message.
- Allow report: Determines whether to allow sending a delivery confirmation mail for a delivery confirmation mail request.

Read reply

This menu allows you to determine whether to request a read confirmation mail to a recipient, and whether to allow sending read confirmation mail to a sender.

- Request reply: Determines whether to request a read confirmation mail for a Multimedia message.

- Allow reply: Determines whether to allow sending a read confirmation mail for a read confirmation mail request.

Auto retrieve

This menu allows you to determine whether to automatically download Multimedia messages when they arrive.

Validity period

This menu allows you to configure the term of validity for a message when transmitting a Multimedia message. The message will be saved in the Multimedia server only for the configured term.

Slide duration

This menu allows you to configure the duration of each page when writing the message.

Message size

This menu allows you to configure the maximum size of a Multimedia message when writing the message.

Messages

Multi. msg centre

The details for the Multimedia gateway are pre-loaded onto your handset and should not be changed. If you change or delete these by mistake contact 3 customer services for support.

You can add or edit the profile of multimedia message except the default profile.

Email

This menu allows you to edit, delete and add an Email account.

To set up an Email account, do the following.

1. Select Messages/Settings/Email after pressing the  key in the idle screen.
2. Press the right soft key [Edit].
3. Enter details **Username** (your phone number with Country code without + eg 447782227302), **Password**, **Email address**, **Reply email address**, etc.
4. You can authenticate by pressing the right soft key [Done].



Once you have set up details of your other accounts, you can collect mail from those accounts by retrieving from Mailbox.

To retrieve an email, do the following:

1. Select the mail server you want to retrieve in the Mailbox.
2. Choose the email by using the navigation key.
3. Press the right soft key [Retrieve] or [Synch].
4. Press the  key.



Videomail

This menu allows you to get the video mail if this feature is supported by the network service provider. Please check with your network service provider for details of their service in order to configure the handset accordingly.

Voicemail

This menu allows you to get the voice mail if this feature is supported by the network service provider. Please check with your network service provider for details of their service in order to configure the handset accordingly.

ExpressLink

You can order ExpressLink from WAP service providers. ExpressLink is notifications of, for example, news headlines and it may contain a text message or address of a WAP service. For availability and subscription, contact your WAP service provider.

Info. Service

Info service messages are text messages sent by the network to GSM phone users. They

provide general information such as weather reports, traffic news, taxis, pharmacies, and stock prices. Each type of information is associated with a number, which can be obtained from the service provider. When you receive an info service message, a popup message will indicate a new message receipt or the info service message will be displayed directly.



6.My stuff

My stuff

Images

This application enables you to view still images. The image files saved in the handset are represented by thumbnails. Select the desired image to view the enlarged image.

Notice

Features within the Edit Image might not work due to large image size or lack of internal phone resource. For example, Rotate will not work for images greater than 640x480 and 320x240.

Press the left soft key [Options] to display the following popup menu items (in 1. Image list).

- View: You can view the selected image.
- Create new folder: You can create new folder.
- Send: Enables the selected image to be sent via MMS, Email and Bluetooth.
- Files
 - Move: Enables the file to be moved other folder.
 - Copy: Enables the file to be copied other folder.

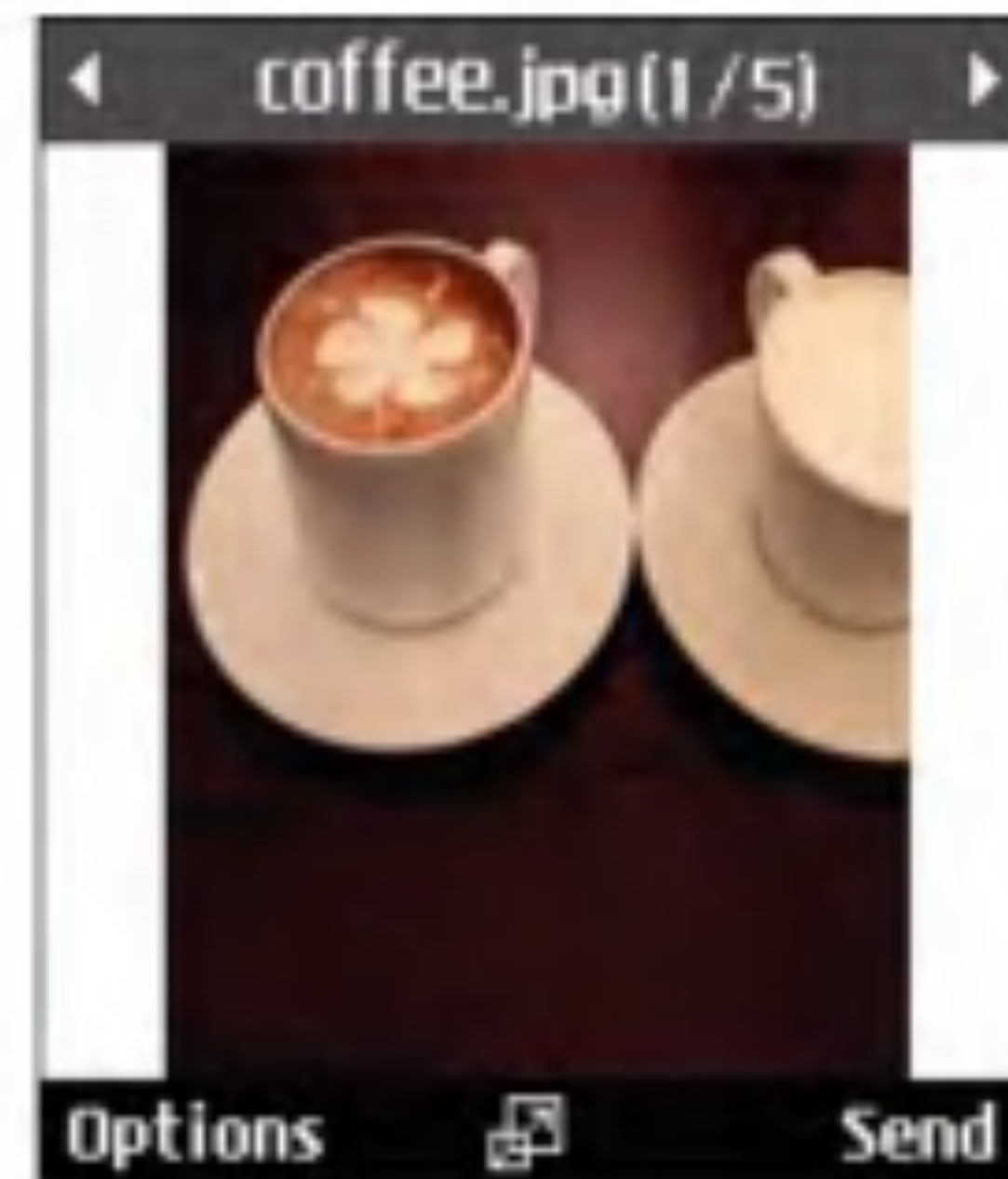

- Rename: Enables the image to be renamed.
- Edit: Enables the image to be edited.
- Info: Shows information about the selected image file.
- Delete: Deletes the selected image.
- Mark/Unmark: You can mark or unmark the selected file.
- Main screen theme: You can set an image as the screen theme (Home screen, Outgoing call, Switch on, Switch off).
- Front screen theme: You can set an image as the screen theme (Home screen, Outgoing call)

- Slide Show: You can start the slide show.
- Sort by: Sorts images.
- List/ Grid view: You can set the view style.
- Memory status: Shows the current memory usage.

Press the left soft key [Options] to display the following popup menu items (in 2. Picture Viewer).

- Go to list: moves to the application list.
- Send: Enables the selected image to be attached to a message and the message sent.
- Files
 - Edit picture: You can edit the image.
 - File info.: Shows information about the selected image file.
- Delete: Deletes the selected image.
- Zoom: You can zoom in and out the image.
- Main screen theme: You can set an image as the screen theme (Home screen, Outgoing call, Switch on and Switch off).

- Front screen theme: You can set an image as the screen theme (Home screen, Outgoing call)
- Slide show: You can start the slide show.

Videos

This application plays recorded video (.3gp or MPEG4 files). Select a desired video.

The following options are provided by the Video Player.

There are two scenarios;

- 1) Mute/Unmute status and
- 2) Pause status

Press the left soft key [Options] to display the following popup menu items (when 1. Unmute/Mute status).

- Send: Enables the selected video to be sent via MMS, Email and Bluetooth.
- Delete: Deletes the selected video file.
- File info.: Shows information about the selected video file.

My stuff

- Sound theme: You can set an video file as the sound theme (Voice ringtone, Video ringtone).
- Video Size: Enables the selected video to be shown as Normal and Landscape. In Play mode, you can change the video size to press  key.
- Mute/Unmute:Mutes/Unmutes the sound temporarily.
- Set repeat: Repeats the video file.
- Previous file: Plays the previous video file.
- Next file: Plays the next video file

Press the left soft key [Options] to display the following popup menu items (when 2. Pause status).

- Send: Enables the selected video to be sent via MMS, Email and Bluetooth.
- Delete: Deletes the selected video file.
- File info.: Shows information about the selected video file.

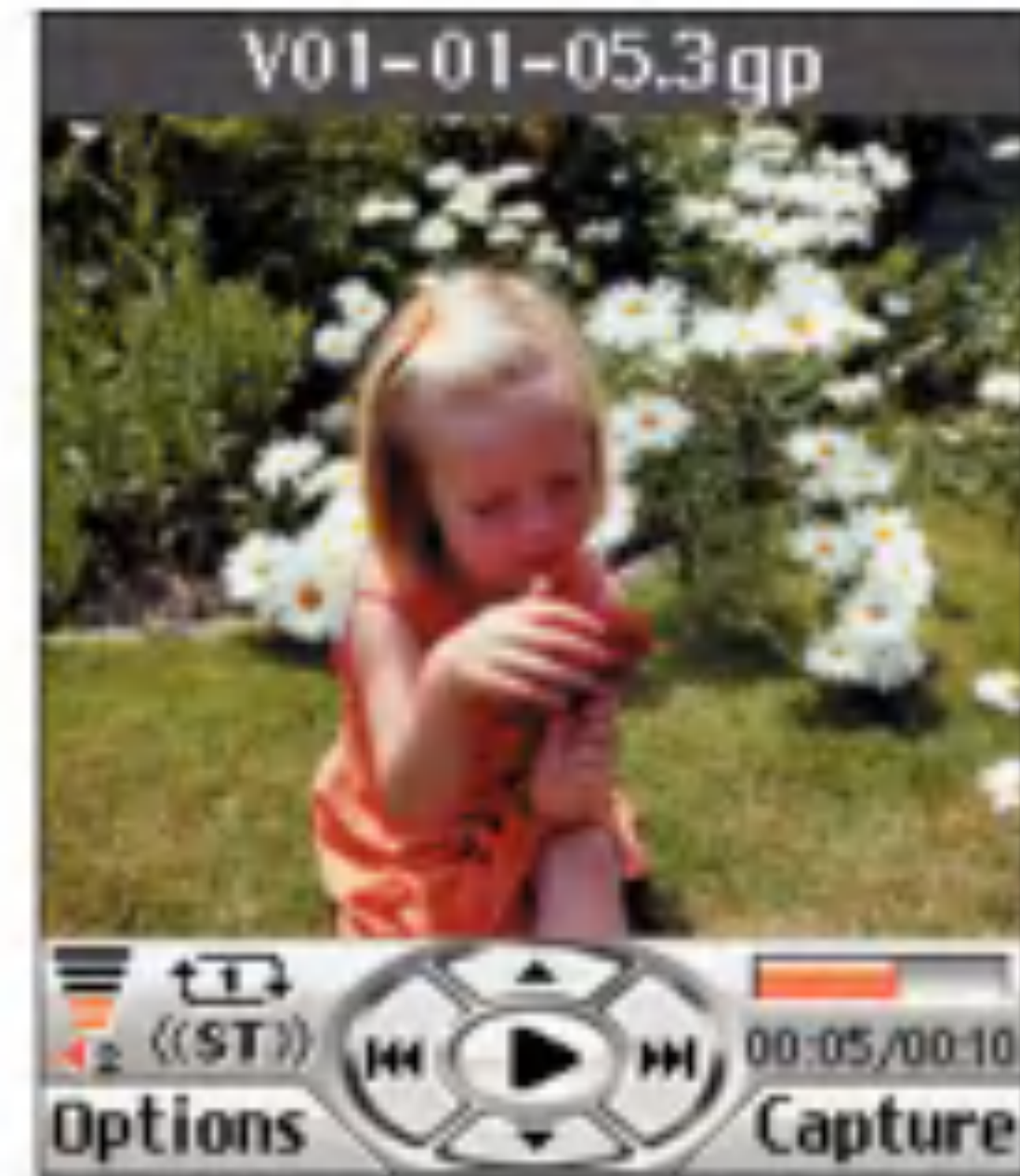

- Sound theme: You can set an audio file as the sound theme (Voice ringtone, Video ringtone).
- Video Size: Enables the selected video to be shown as Normal and Landscape. In Play mode, you can change the video size to press  key.
- Capture: Captures an image from the video file.
- Set repeat: Repeats the audio file.
- Previous file: Plays the previous video file.
- Next file: Plays the next video file.

Press the left soft key [Options] to display the following popup menu items

- Play: Plays the selected video file.
- Create new folder: You can create new folder.
- Send: You can attach the selected video file to a message and send the message if not content protected.
- Files
 - Move: Enables the file to be moved other folder.
 - Copy: Enables the file to be copied other folder.
 - Rename: Enables the video to be renamed.
 - Info: Shows information about the selected video file.
- Delete: Deletes the selected video file.
- Mark/Unmark: You can mark or unmark the selected file.
- Sound theme: You can set an video file as the sound theme (Voice ringtone, Video ringtone).

- Sort by: Sorts video files.
- List/ Grid view: You can set the view style.
- Memory status: Shows the current memory usage.

Sounds



This application plays MP3, MIDI and AAC files so that you can listen to them. Select your desired audio file in the list mode showing audio files. The following options are provided by the My sounds in the Audio Player.

There are two scenarios: 1) Unmute status and
2) Mute status.

Press the left soft key [Options] to display the following popup menu items (when 1. Unmute status).

- Send: Enables the selected audio file to be sent via MMS, Email and Bluetooth
- Delete: Deletes the selected audio file.
- File info.: Shows information about the selected audio file.

My stuff

- Sound theme: You can set an audio file as the sound theme (Voice ringtone, Video ringtone, Message tone, Switch on and Switch off).
- Mute: Mutes the sound temporarily.
- Set repeat: Repeats the audio file.
- Play in background: If the function is activated it is still possible to listen to background music without a headset even though the flip is closed. The music can also be heard when switching menus using the  key in the state of flip open, but not using the  key nor the  key.

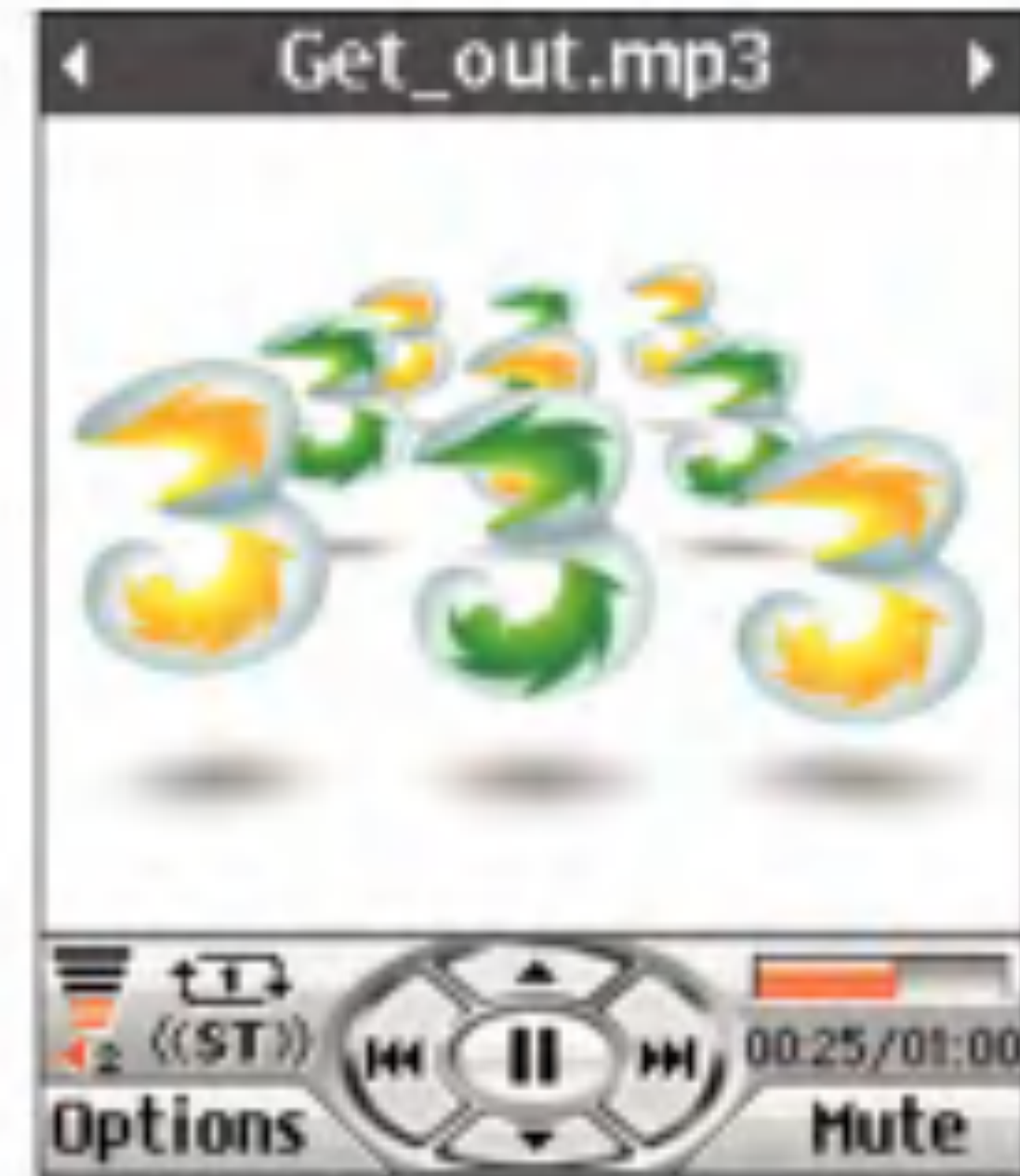

The Call and alarm having higher priority than a background music will make it paused and resumed, but such a message tone, flip tone, key tone, and confirmation tone never happen during background music.

- Equalizer: You can set the equalizer.
- Previous file: Plays the previous audio file.
- Next file: Plays the next audio file.



Press the left soft key [Options] to display the following popup menu items (when 2. Mute status).

- Send: Enables the selected audio file to be sent via MMS, Email and Bluetooth
- Delete: Deletes the selected video file.
- File info.: Shows information about the selected audio file.
- Sound theme: You can set an audio file as the sound theme (Voice ringtone, Video ringtone, Message tone, Switch on and Switch off).
- Unmute: Unmutes the sound temporarily.

- Set repeat: Repeats the audio file.
- Play in background: If the function is activated it is still possible to listen to background music without a headset even though the flip is closed. The music can also be heard when switching menus using the  key in the state of flip open, but not using the  key nor the  key.



The Call and alarm having higher priority than a background music will make it paused and resumed, but such a message tone, flip tone, key tone, and confirmation tone never happen during background music.

- Equalizer: You can set the equalizer.
- Previous file: Plays the previous audio file.
- Next file: Plays the next audio file.

Press the left soft key [Options] to display the following popup menu items

- Play: Plays the selected audio file.
- Create new folder: You can create new folder.
- Send: Enables the selected image to be sent via MMS, Email and Bluetooth.

■ Files

- Move: Enables the file to be moved other folder.
 - Copy: Enables the file to be copied other folder.
 - Rename: Enables the image to be renamed.
 - Info: Shows information about the selected audio file.
- Delete: Deletes the selected image.
 - Mark/Unmark: You can mark or unmark the selected file.
 - Sound theme: You can set an audio file as the sound theme (Voice ringtone, Video ringtone, Switch on, Message tone, Switch off).
 - Play in background: If the function is activated it is still possible to listen to background music without a headset even though the flip is closed. The music can also be heard when switching menus using the  key in the state of flip open, but not using the  key nor the  key.

My stuff

The Call and alarm having higher priority than a background music will make it paused and resumed, but such a message tone, flip tone, key tone, and confirmation tone never happen during background music.

- Sort by: Sorts audio files.
- Memory status: Shows the current memory usage.

Applications

For further details. see the page 92, (Menu 9 Applications)

External memory

If your phone is installed the multimedia memory card in the card slot, you can save images, sounds, and videos on the memory card. You can check the current status of the external memory in Memory status menu.

Play lists

This option enables you to view a list of saved audio files.

You can add an audio file stored in your phone and memory card.

Press the left soft key [Options] to display the following popup menu items.

- Play: Plays the selected audio file.
- Add new: You can add a new file from the sound list.
- Edit: You can edit the selected file.
- Delete: Deletes the selected file.
- Delete all: Deletes all the stored audio files.
- Set repeat: Select desired repeat mode using the navigation key.
- Rename: You can rename the selected file

7.Multimedia

Multimedia

Video camera

This application enables you to record a video clip. You can play and watch a saved video file while using this function. Once recorded, a video clip can be sent by Multimedia message or Email or Bluetooth.

Press the left soft key [Options] to display the following popup menu items.

- Quality: Determines the quality of a video clip.
- Light: Determines the light operation.
- Zoom: Determines the zoom rate.
- Brightness: Determines the brightness.
- WB: Determines the white balance.
- Night mode: Determines the night mode.
- Effect: Determines the special effect to the video clip.
- Duration: Determines the duration.
- Sound: Determines the sound when the video camera is recorded
- Memory: Determines the memory.



Using Camera/Video Camera menu with flip closed

1. Press the camera key for a long time.
2. Select the desired menu by using the side keys, and then press the camera key.
3. In the Camera mode, focus on the subject to capture the image, and then press the camera key. The picture will be saved automatically. In the Video Camera mode, focus on the subject to record the video, and then press the camera key to start and stop video recording. The video will be saved automatically.

Camera

This application enables you to take a still picture. You can take a picture in your desired size, and use it for the contacts photo, home screen and other more general purposes. Once taken, a still image can be sent by Multimedia msg or Email or Bluetooth.

Press the left soft key [Options] to display the following popup menu items.

- Size: Determines the size of an image.
- Quality: Determines the quality of an image.
- Light: Determines the light operation.
- Multishot: Determines whether to enable multi-shot photography.
- Zoom: Determines the zoom rate.
- Brightness: Determines the brightness.
- WB: Determines the white balance.
- Night mode: Determines the night mode.
- Timer: Determines the delay time.
- Effect: Determines the special effect to the picture.



- Sound: Determines the sound when the shutter is pressed.
- Memory: Determines the memory

Notice

When you take a picture in 1280x960, 640x480, 320x240, 160x120 and 176x146 size, you can see the added area on both sides of the screen compare with the preview image .

Multimedia

Voice recorder

This function allows you to record a voice memo. You can record voice messages with each message up to 60 seconds.

Press the left soft key [Options] to display the following popup menu items.

- Quality: Determines the quality of a recorded voice.
- New recording: Determines the recording a new voice.
- My stuff: Show the voice lists recorded.

Settings

Video camera

For further details, see the page 84.

Camera

For further details, see the page 85.

Voice recorder

Allows you to set the duration and quality for recording the voice by using the left/right navigation key.

Memory status

For further details, see the page 51.

8. Contacts

Contacts

This menu allows you to save and manage contact address information. The Contacts functions provide functions to add a new address or search saved contact addresses by name, phone number and group information.

Add new

This menu allows you to add a new contact address. You can input contact address information including name, phone numbers, email addresses, group information items, memo, homepage address, ringtone, and avatar or image (photograph).

You have to select Handset or USIM card memory using the left and right navigation keys.

Search

This menu allows you to search your contact addresses. Generally the search operation is performed by name & number. In the search window, the current search function and results for the search condition are displayed.

On the screen, a saved image or avatar is displayed for the selected contact address. You



can change the configuration in the Show image/avatar(Menu 8.7.2) menu so that no image or avatar is displayed. You can also make a phone call or send a message to the selected phone number.

Speed dials

This menu allows you to configure speed dial numbers. You can select a number as a speed dial from 3 to 9. You can configure speed dial numbers for any of the 7 numbers for a specific contact address so that a contact address may have multiple speed dial numbers.

Groups

This menu allows you to manage group information. By default, there are 4 groups: family, friends, colleagues and school. You can also configure ringtone for a group so that the group ringtone sounds when a call from a specific contact address within that group arrives and there is no ringtone configured for the contact address.

Service dial numbers

This menu allows you to make a call to one of the numbers provided by 3 Customer Service by moving the highlight to the desired number and pressing the  key. (E.g. 3 customer service, mail, 3 customer finance, etc.)

Own number

Allows you to display your phone number in the USIM card.

Settings

Allows you to set the display way as for the following items.



Display data

Handset & USIM / Handset / USIM

Show image/avatar

On / Off

Copy all

This menu allows you to copy all information from your USIM card, e.g. name, handset number, etc., to your handset. If a name is duplicated during the copying operation, the information is duplicated.

Contacts

- Handset to USIM: You can copy the entry from the handset memory to the USIM card (not all the data will be copied).
- USIM to handset: You can copy the entry from the USIM card to phone memory.

Move all

This menu allows you to move all the information from your USIM card, e.g. name, handset number etc., to your handset. This differs from the Copy all operation in that the target information is saved only in the destination location.

- Handset to USIM: You can move the entry from the phone memory to the USIM card.
- USIM to handset: You can move the entry from the USIM card to phone memory.

Clear contacts

This menu deletes contact address information. You can delete contact addresses saved in the handset memory and you can delete the numbers saved on the USIM card.



9.Applications

Applications

This Handset supports Java™ so that you can download games from Today on 3, and play them on your handset.

Games can be downloaded from the game page of the H3G portal site. Users can go to that page using the  key.

The  key loads the H3G portal page.

Select the services icon before users should select the game icon in the main page. (usually it is the page that appears when a user selects the tab beside "Today on 3") In the game page, users can view the game list, select, and download games. Or, users can use the Download games & apps menu to go to the game page.

Note

Please note that downloading a game usually requires additional charge.

My games & apps

This menu is used to locate and run downloaded applications, e.g. games. Select Download to view the list of applications that have been downloaded to the handset.

Download games & apps

This menu is used to go directly to the game download page, so that users can browse and select the games to download. This is possible because the Internet browser is launching with the game portal URL setting. This URL is specified in the Settings menu - Java Portal URL.

By default, the setting is on the game page of the H3G portal (or, it can be left blank if the Operator does not specify the URL). If users want to change the default setting, the game portal URL can be modified in the Settings menu.

Settings

This menu is used to configure the Java Internet portal site to connect to in order to Download games & apps.

If this menu is selected, the list of currently saved Java Internet portal sites and the configured displayed.

The first Settings screen: Shows the item list if there are saved items.

1. Select an item using the up or down navigation keys.
2. Press the  key to activate the selected item service.
3. Press the left soft key [Options] to display the popup menu.

Press the left soft key [Options] to display the following popup menu items.

- Activate: Activates the selected item.
- Add new: New profile is added.
- View: Shows the contents of the selected item.

***.Organiser**

Organiser

Calendar

Monthly Schedule Management

1. Select the Organiser from the top menu.
2. Select Calendar and press the **OK** key.
3. The monthly schedule view is displayed.
4. Initially, the cursor appears on today's date according to your handset settings.
5. You can move the date cursor to the desired location using the up, down, left and right navigation keys.
6. On a date where a schedule item is saved, corresponding icons and the number of saved schedule items are displayed on the bottom left of the screen.

Adding a New Schedule Item



1. Select the left soft key [Options] in the Monthly schedule management screen, select the Add new from the popup menu and then press the **OK** key. Alternatively, select the right soft key [Add] in the Monthly schedule management screen.



2. Input the desired date using the numeric keys.
3. Input the desired time using the numeric keys.
4. Input the subject.
5. Select the repeat type using the left and right navigation keys.
6. Select the alarm type using the left and right navigation keys.
7. Select the user setting type using the left and right navigation keys.
8. Input the desired duration using the numeric keys.

9. Select the expiration type using the left and right navigation keys.
10. Input the expiration date using the numeric keys.
11. Press the  key to save the new schedule item.

Deleting a Schedule Item

1. Select the left soft key [Options] in the Monthly schedule management screen, select Delete, and then press the  key.
2. Popup menus including Previous entries and All entries will be displayed.
3. Select Previous entries and press the  key to delete all schedule items prior to today.
4. Select All entries, and press the  key to delete all of the schedule items.

Set holiday

1. Select the left soft key [Options] in the Monthly schedule management screen, select Set holiday and then press the  key to display the Holiday configuration popup window.

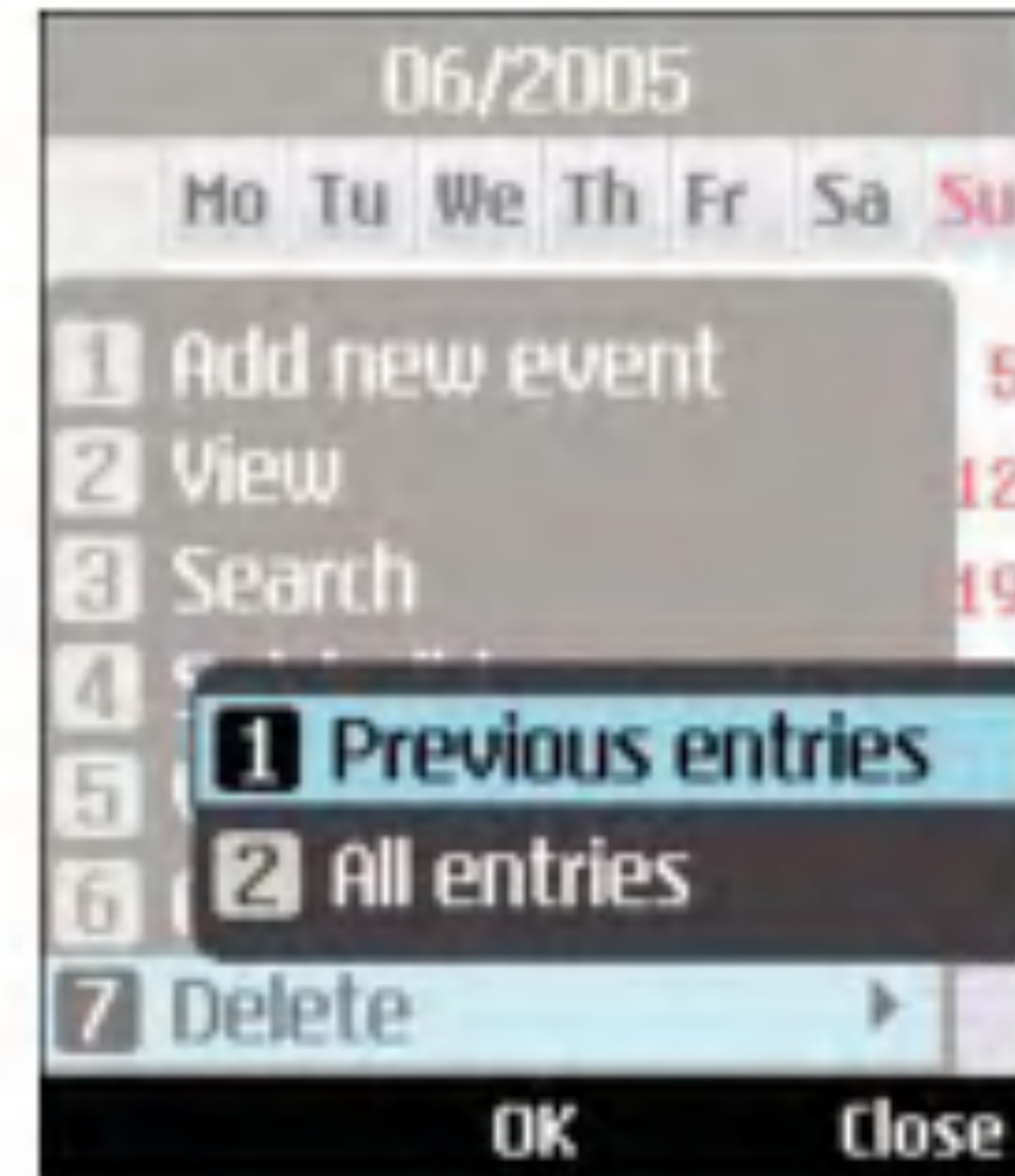

2. Supported holiday types include On the day, Weekly, Monthly, Annually and Multiple setting.
3. Select the holiday configuration type and press the  key to configure the holiday.
4. The date corresponding to the configured holiday is represented in red in the Monthly schedule management screen.

Organiser

Searching for a Schedule Item

Select the left soft key [Options] in the Monthly schedule management screen, select Search and then press the **OK** key to display the Search schedule items screen.

1. Input the desired subject of the schedule item to find.
2. Select the In type to find.
3. Press the **Enter** key.
4. If there are schedule items that meet the search criteria, the schedule items are displayed. If there is no schedule item satisfying the search criteria, No match schedule Item message appears.

Moving to a Specific Date

1. Select the left soft key [Options] in the Monthly schedule management screen, select Go to date and then press the **OK** key to display Go to date window.
2. Input the desired date to move to and press the **OK** key.



3. The date cursor of the Monthly schedule management screen will then move to the specified date.

To do

To do Enquiry

1. Select the Organiser from the top menu.
2. Select the To do item and press the  key.
3. The saved To do list is displayed.

Adding To do Items

1. To add a new To do item, select Add new using the left soft key [Options] in the To do enquiry screen or select the right soft key [Add].
2. Input Date, notes and priority when you add an item.
3. Press the right soft key [Done] to save the To do item.

To do Delete

1. Select the desired item(s) to delete from the To do list and press the Delete using the left soft key [Options] to delete the To do item.

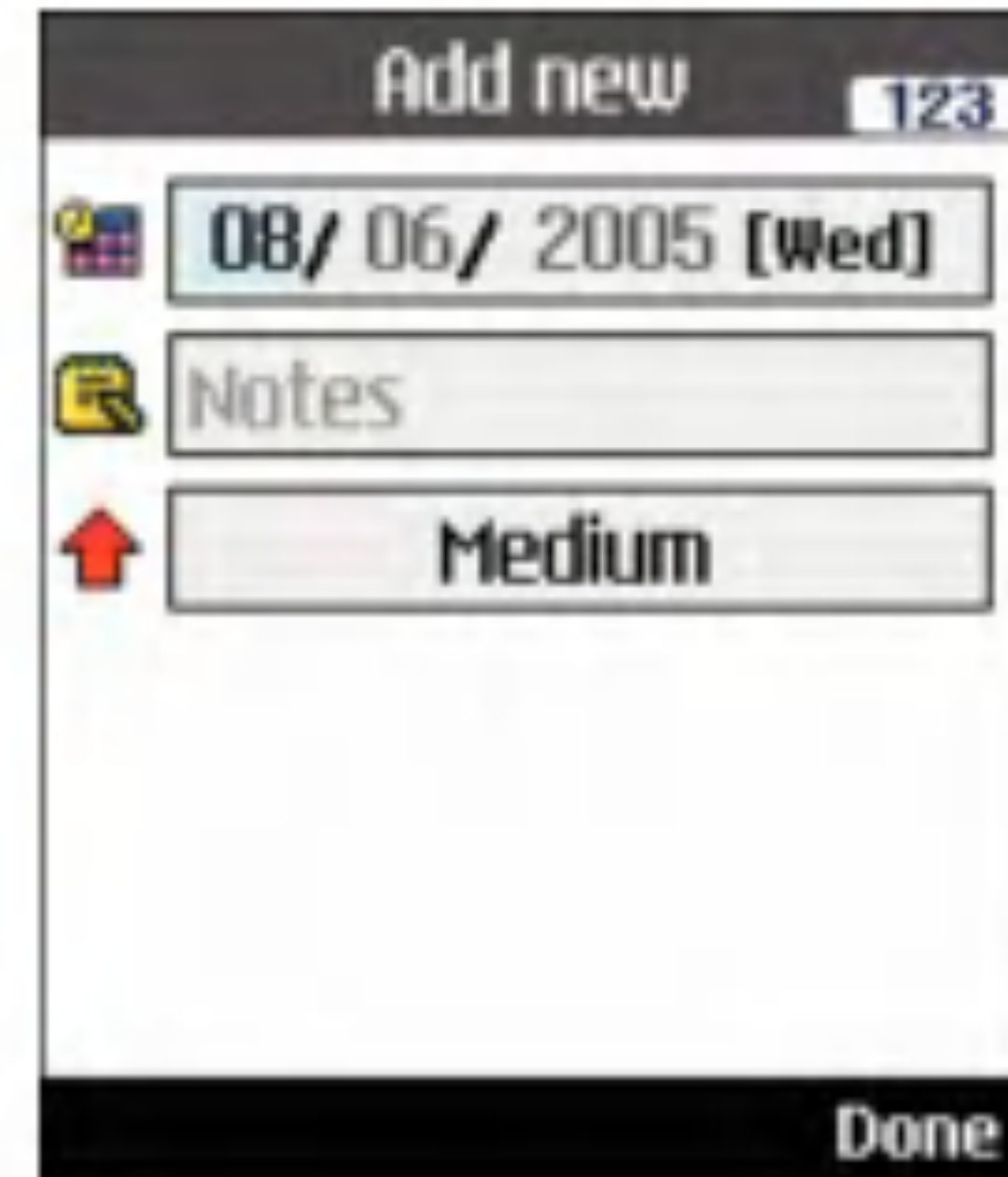

Finished/Not finished

1. If you wish to mark an item in the saved To do list as done, select the item from the To do list.
2. Select the Done using the left soft key [Options] to draw a line over the schedule item to mark it as done.
3. To cancel Done, select the Not yet done.

Mark/Unmark

1. You can Mark/Unmark desired (all) item(s) from the list.
2. By this option you can delete marked items.

Organiser

To do Detailed View

To view detailed information, select the desired item from the To do list and press the **OK** key to display the detailed view screen about the item.

Memo

Saved Memo's

1. Select the Organiser from the top menu.
2. Select the Memo item and press the **OK** key.
3. The saved memo list is displayed.

Memo Add

1. To add a new memo, select Add new using the left soft key [Options] in the General memo screen or select the right soft key [Add].
2. Input the contents of the memo to be saved.
3. Press the **Enter** key to save the memo.

Memo Lock/Unlock

1. Select the desired item to lock from the



saved memos list. The locked memo is converted to a secret memo.

2. Select Move to secret memo using the [Options] key to lock the memo item.
3. To release the lock again, select Move to memo in the Secret memo item.

Memo Edit

You can edit the selected memo.

Memo Delete

1. Select the desired item(s) to delete from the Memo list and select Delete using the left soft key [Options] to delete the memo.

Secret memo

1. Select the **Organiser** from the top menu.
2. Select the **Secret memo** item and press the **OK** key.
3. To view or delete the memo set up as a secret memo, you have to input the password configured in the phone.

Date finder

The date finder shows the number of remaining days while changing the day.

Dateulator

■ Dateulator enquiry

1. Select the **Organiser** from the top menu.
2. Select the **Dateulator** item and press the **OK** key.
3. The saved **Dateulator** list is displayed.

■ Adding Dateulator items

1. To add a new **Dateulator** item, select **Add new** using the left soft key [Options] in the **Dateulator** enquiry screen or select right soft key [Add].



2. Input the Date, and notes when you add an item.
3. Press the right soft key [Done] to save the item.

■ Mark/Unmark

1. You can **Mark/Unmark** desired (all) item(s) from the list.
2. By this option you can delete marked items.

■ Dateulator Delete

Select the desired item(s) to delete from the **Dateulator** list and press the **Delete** using the left soft key [Options] to delete the **To do** item.

Organiser

■ Dateulator Detailed View

To view detailed information, select the desired item from the Dateulator list and press OK key to display the detailed view screen about the item.

■ Show home screen/ Do not show home screen

By setting Show home screen, you can see the Remaining days for this item (D-Day) on Idle screen top left corner.

Settings

Calendar

You can change Calendar Default view and Week start time to desired options. Press right soft key [Done] to save settings in phone.

Memory info.

Allows you to view each memory status of the organiser menu.

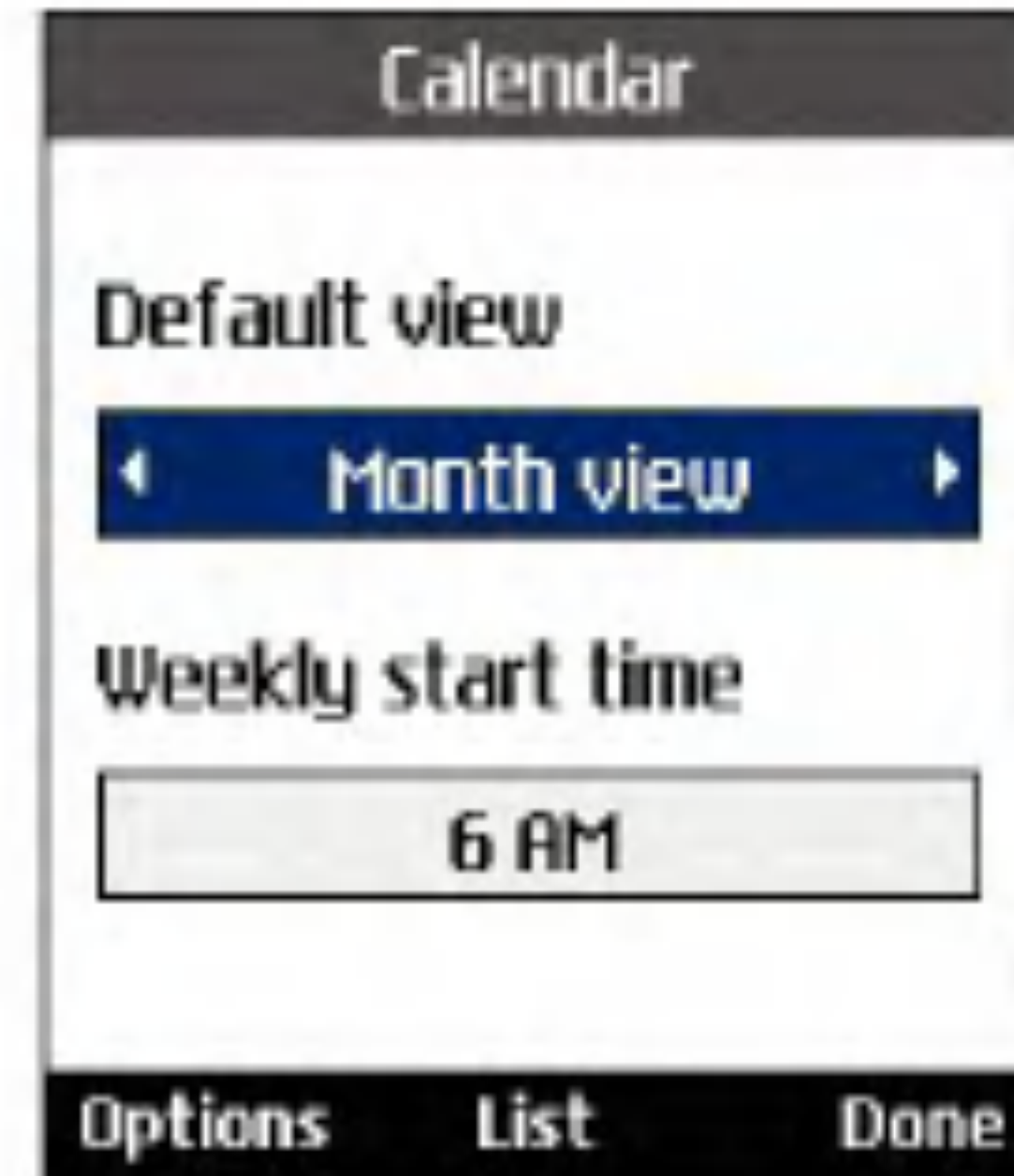

Clear all

Allows you to delete all the saved items, you need to input the security code.

0.Tools

Tools

Quick menu

Quick menu allows you to add your own favourites to the list already provided. Once you create your own menu, you can access the desired function quickly in the idle screen by pressing the up navigation key. To move to your desired menu directly, select your desired menu from the Favourites menu press the up and down navigation keys.

- **Add new:** In the [Empty] list, press the right soft key [Add]. Select the item from the menu and save the desired menu item.
- **Open:** In the added menu items list, press the left soft key [Options] or the  key. To move to your desired menu directly.
- **Edit:** In the added menu items list, press the right soft key [Edit] or the left soft key [Options]. Select Edit from the menu to edit a saved menu item.
- **Delete:** In the added menu items list, press the left soft key [Options]. Select Delete from the menu to delete a saved menu item.
- **Delete all:** In the added menu items, press the left soft key [Options]. Select Delete all



from the menu to delete Quick menu items 7 to 0.

- **View info.:** In the added menu item list, press the left soft key [Options].

Select View info. from the menu to view the information about the actual location of the added menu item.

Alarm clock

The alarm function allows you to set up multiple separate alarms. You can also set the time, repetition interval and alarm sound.

- Select your desired alarm to configure in the alarm list. If there is no alarm, press the right soft key [Add] to add a new alarm.
- Set/Cancel alarm: Select desired set time mode using the navigation key.
- Input alarm time: Input your desired alarm time by specifying hour and minute. If the time format is 12 hours-based format, you have to select either 'am' or 'pm' using the  key.
- Select repeat mode: Select desired repeat mode using the navigation key.
- Select bell: Select the bell to use for the alarm using the navigation key.
- Input memo: Input alarm name.

When you have completed configuration, press the  key to save the changed alarm configuration.



Note

The alarm function does not work if the handset is turned off.

Tools

Connectivity

Bluetooth

Paired devices

Select the Paired devices by pressing the OK key. This function allows you to view the list of all devices that are paired with your phone at once.

- Adding a new device
 1. Select the Add New to search the device can be connected in range.
 2. If you want to stop the searching , press the right soft key [Cancel].
 3. All of the serched devices are displayed the popup menu.

Select the desired device by pressing the OK key, and input the password.

- Assigning a short name

Press the OK key, to rename the paired device.
- Connecting/Disconnecting the device
 1. Select the Connect, allows you to active to the bluetooth connection.

2. If you want to close the connection to the selectde device, select the Disconnect.

Note

This options is appeared when the device connected with your phone is the headset.

Bluetooth profiles are Headset profile, Handsfree profile, Dial Up Networking Profile, Object Push Profile and Serial Port Profile.

- Please use a headset that conforms to handsfree, headset profile authentication.

- Deleting devices

Select Yes to delete the selected device.
- Deleting all the devices

Select Yes to delete all the devices in the list.

Settings

This menu allows you to configure the profile for a bluetooth.

- Bluetooth usage

Set on or off the bluetooth using the left/right navigation key.

- My handset's visibility:

1. Select the Shown to all, shows your phone to other bluetooth devices.
2. Select the Hidden, shows your phone only to the paired device.

- My Handset's name

Allows to you change the handset's name can be seen by other bluetooth devices.

Server synchronisation

The Server sync function synchronises the data in a phone and the data on a server such as contact address information, schedule items, and to do items via a wireless network.

Connect

Select Server sync from the Connectivity menu and then press the **OK** key.

Select the Connect item and then press the **OK** key.

Connect to the server with the selected server profile and the synchronization animation is displayed while the synchronization is performed.



Log

Select a Server sync item in the Connectivity menu and then press the **OK** key. Select Log item and then press the **OK** key to view the log for the last synchronisation operation performed.

Server synch. centre

This menu allows you to configure the profile for a Sync Server.

- Adding a new profile

1. In the Server synch. centre screen, press the left soft key [Options] key and select Add new to add a new profile.

Tools

2. Input and choose the Profile name, Host address, Username, Password, Contacts, Contact name, Calendar, Calendar name, To do, To do name and Access point.
 3. Press the  key to save the new profile.
- Editing a profile
 1. Select a profile to edit.
 2. Press the left soft key [Options], select Edit, and edit the selected profile.
 - Deleting profiles
 1. Press the left soft key [Options] and select Delete.
 2. Select Yes to delete the selected profile.
 - Selecting a server

Select a desired server profile to synchronise in the Server synch. centre screen and then press the  key.

Calculator

The calculator function allows you to add, subtract, multiply and divide. You can input numbers using the number keys, and operators



using the up, down, left, and right navigation key.

You can input a decimal point by pressing the  key.

Whenever you press the  key, characters are sequentially deleted in reverse direction.

World time

The World time function provides time information on major cities worldwide.

1. You can view the time of desired country or city using the navigation or  [List].

2. You can select a desired city as a base using the right soft key [set].

Unit converter

This function converts any measurement into a unit you want.

There are 7 types of units that can be converted: Currency, Surface, Length, Weight, Temperature, Volume, and Velocity.

Note

You can input a decimal number by pressing the  key.

Currency

1. Select the Currency menu.
2. Users can set a currency exchange rate using the right soft key [Rate].
3. Input standard unit to view converted value.
4. You can view the value in home country currency unit in Domestic by inputting standard unit in Foreign.
5. Press the right soft key [Reset] to clear the

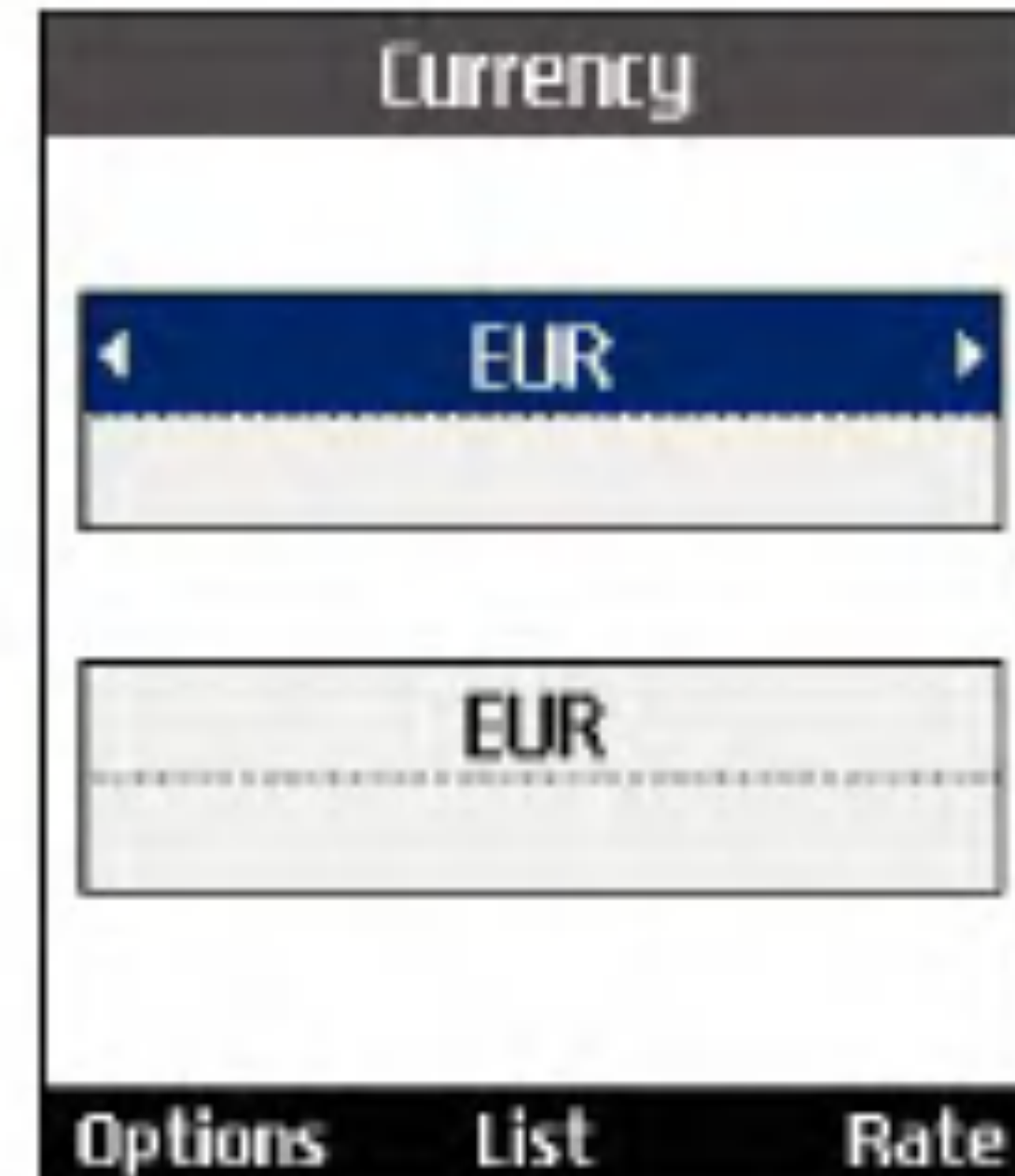

current input field, and locate the cursor in the input field.

6. To exit currency conversion function, press the  key.



Surface

1. Select Surface menu.
2. Select desired unit to convert using the  key [Unit].
3. Input standard unit to view converted value.
4. Press the right soft key [Reset] to clear the current input field, and locate the cursor in the input field.

Tools

5. To exit area conversion function, press the  key.

Length

1. Select Length menu.
2. Select the desired unit to convert using the  key [Unit].
3. Input the standard unit to view converted value.
4. Press the right soft key [Reset] to clear the current input field, and locate the cursor in the input field.
5. To exit length conversion function, press the  key.

Weight

1. Select Weight menu.
2. Select desired unit to convert using the  key [Unit].
3. Input the standard unit to view converted value.
4. Press the right soft key [Reset] to clear the current input field, and locate the cursor in the input field.

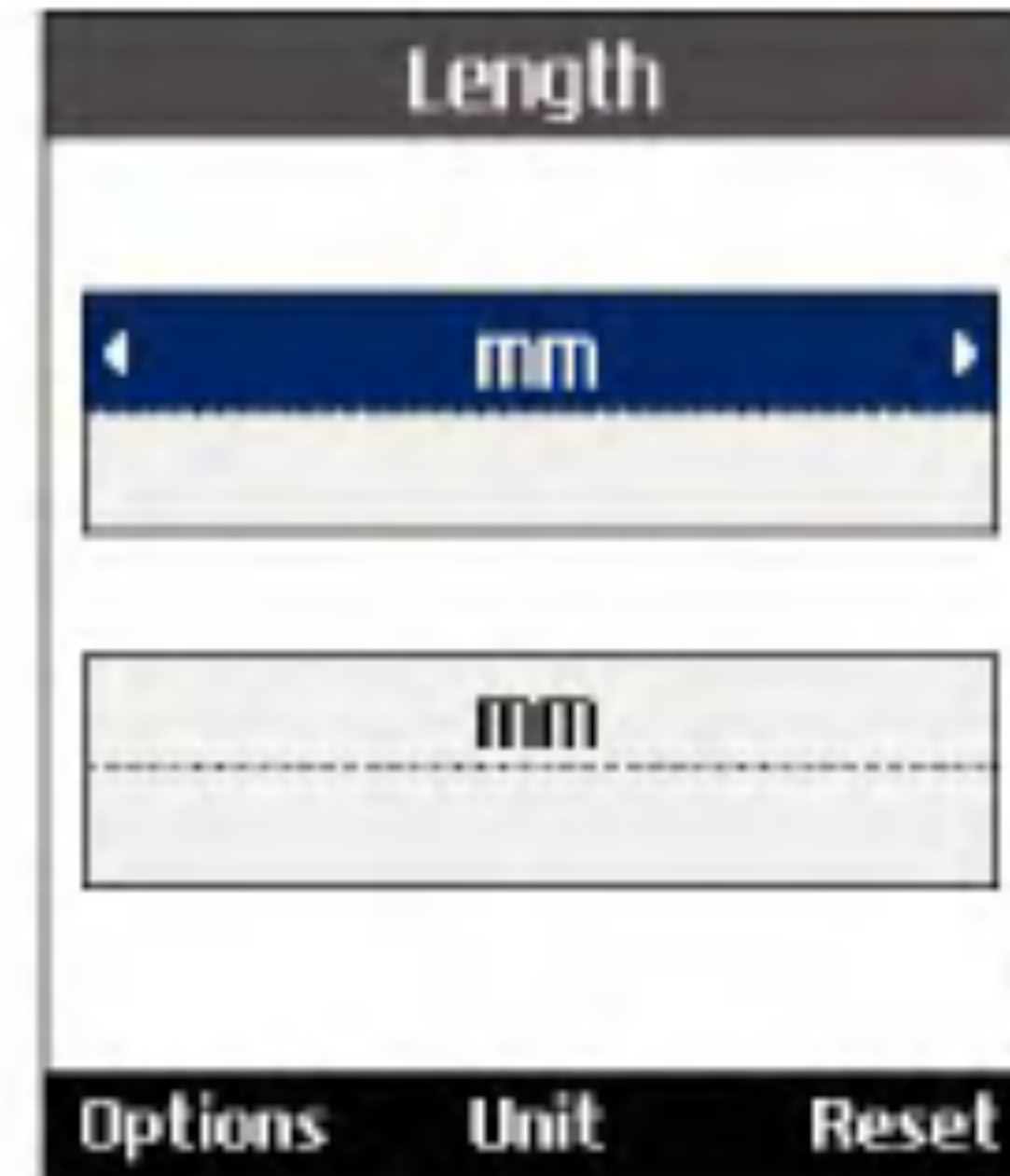



5. To exit weight conversion function, press the  key.

Temperature



1. Select Temperature menu.
2. Input the standard unit to view converted value.
3. Press the right soft key [Reset] to clear the current input field, and locate the cursor in the input field.
4. To exit temperature conversion function, press the  key.

Volume

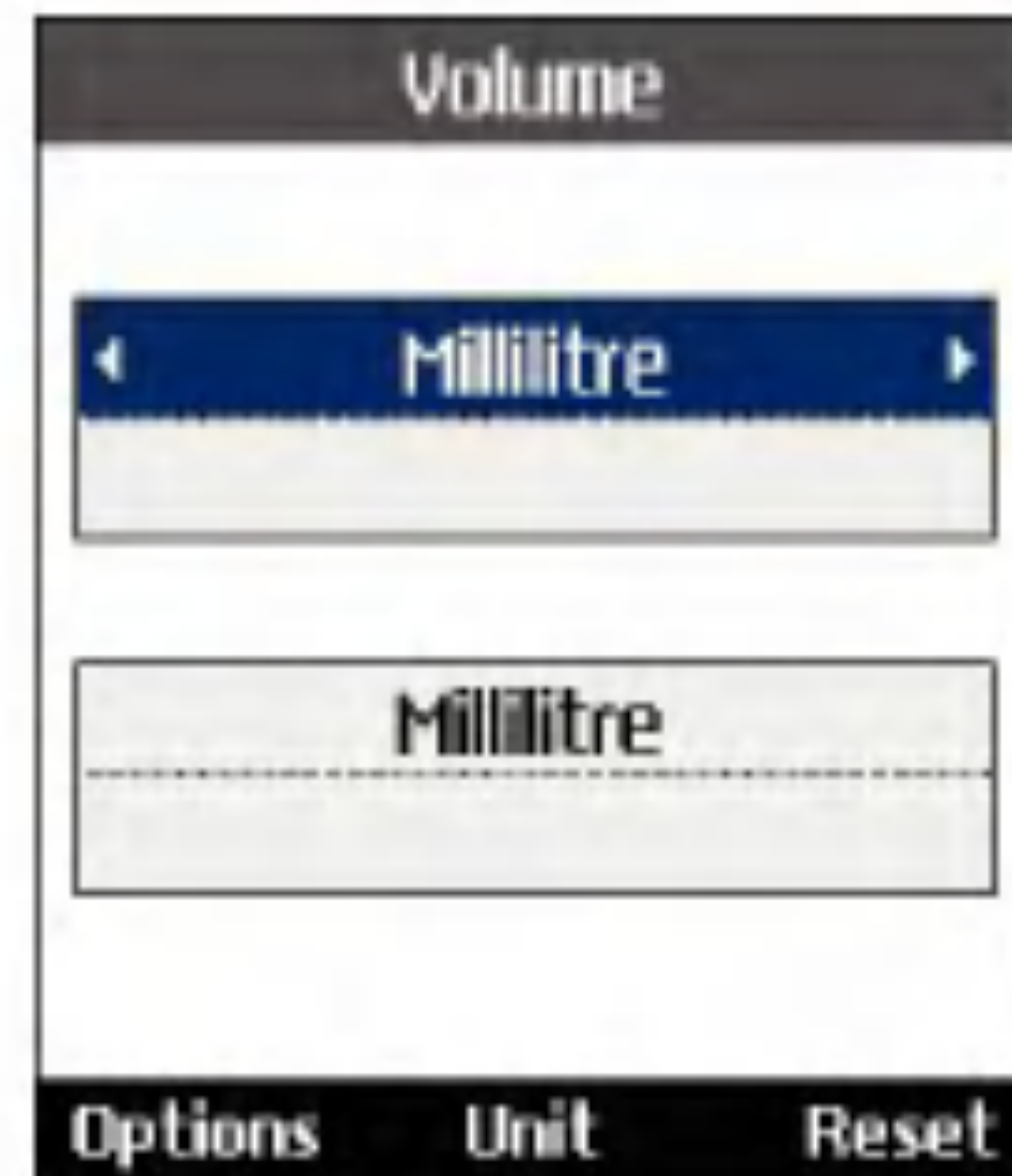
1. Select Volume menu.
2. Select desired unit to convert using the  key [Unit].
3. Input the standard unit to view converted value.
4. Press the right soft key [Reset] to clear the current input field, and locate the cursor in the input field.
5. To exit volume conversion function, press the  key.



Velocity

1. Select Velocity menu.
2. Select desired unit to convert using the  key [Unit].
3. Input the standard unit to view converted value.
4. Press the right soft key [Reset] to clear the current input field, and locate the cursor in the input field.
5. To exit velocity conversion function, press the  key.

#.Calling

Calling

Video calls

My picture size

This menu allows you to configure your own picture size to either Large, Medium or Small.

My picture position

This menu allows you to configure your screen alignment to bottom right or bottom left.



Hide my picture

This menu allows you to hide your picture.

Substitute picture

This menu allows you to substitute your picture with another picture.

Call history

You can access the call register by pressing the  key or the  key. Different icons show you the type of the recent calls registered in the list (see following page for icon description).



- You can view missed, received, dialled and entire call records. Each call record menu provides the following functions.
- You can make a voice or video call to the number in the call record.
- You can save the number in the call record to the Contacts.
- You can send a message to the number in the call record.
- You can view detailed information about the call records such as the date, time and call duration.
- You can clear call records.

Missed calls

Allows you to view missed call records, make a call, send a message and save the number in the Contacts.

Received calls

Allows you to view received call records, make a call, send a message and save the number in the Contacts.

Dialled calls

Allows you to view dialled call records, make a call, send a message and save the number.

All calls

This menu allows you to view all of the missed, received, and dialled call records. You can make a call, or send a message to the number you have selected from the records. You can also save the number in the Contacts.

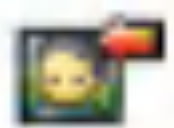

Received video call



Dialled video call



Missed video call



Reject video call



Received voice call



Dialled voice call



Missed voice call



Reject Call

Call duration

Shows call duration time by type. Press the right soft key [Reset] to reset. A security code will be requested.

Last call

Displays the duration of the last call made in hours/minutes/seconds.

Received calls

Displays received call duration.

Dialled calls

Displays dialled call duration.

All calls

Displays overall call duration.

Calling

Call divert

This menu allows you to configure the call divert service which diverts incoming calls to a user-specified number.

1. Press the  key in the idle screen.
2. Press the navigation key down to select Calling and press Call divert.

Voice calls

- All voice calls
Diverts all incoming voice calls unconditionally.
- If busy
Diverts incoming voice calls when the line is busy.
- If no answer
Diverts incoming voice calls when there is no answer.
- If unreachable
Diverts incoming voice calls when the handset is turned off or the handset is out of the network service coverage

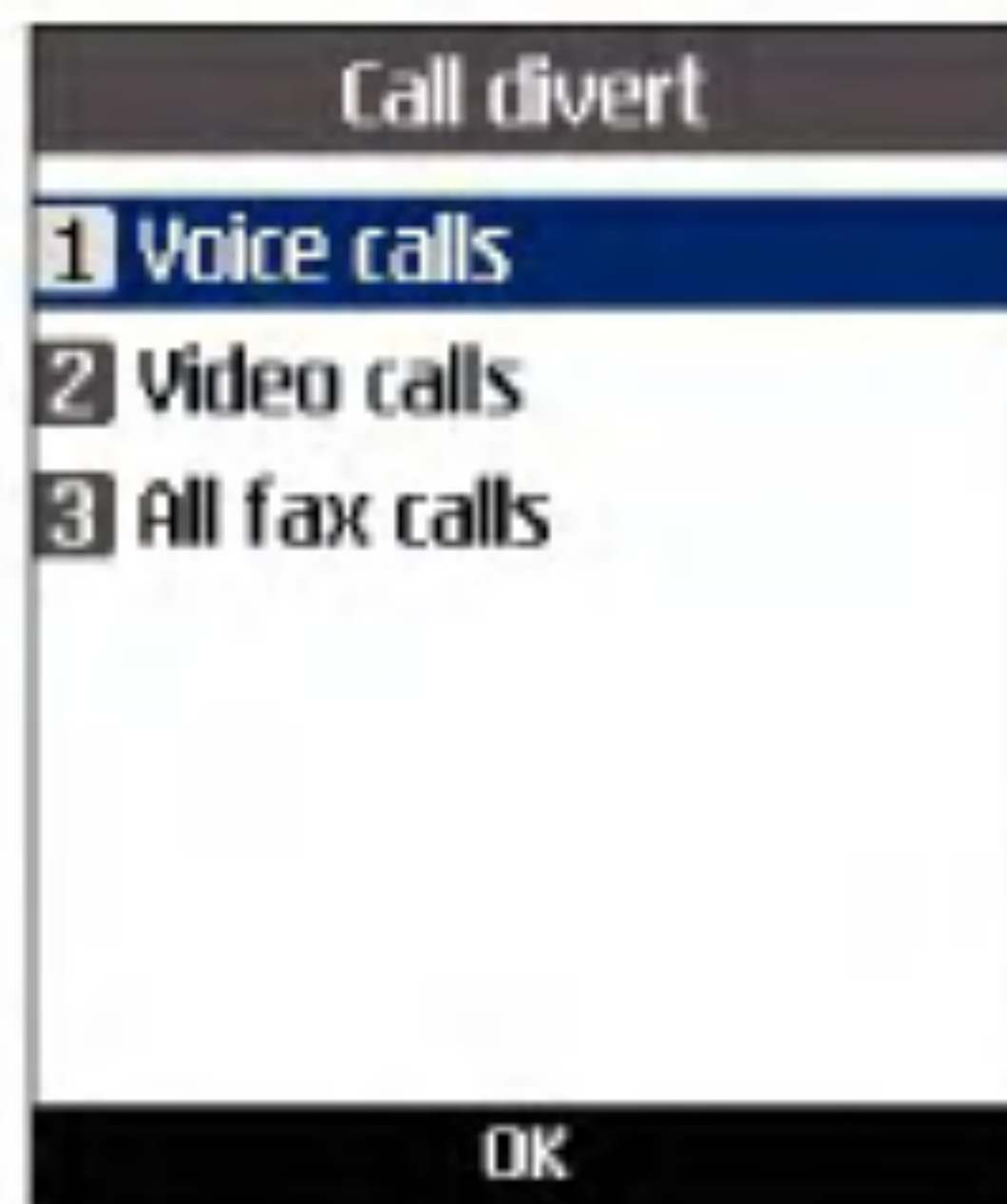

Video calls

You can divert video calls to other 3 handsets that support video calling.

- All video calls
Diverts all incoming video calls unconditionally.
- If busy
Diverts incoming video calls when the line is busy.
- If no answer
Diverts incoming video calls when there is no answer.

- **If unreachable**
Diverts incoming video calls when the handset is turned off or the handset is out of the network service coverage.

All fax calls

Diverts fax calls unconditionally.

Call barring

Call barring allows you to restrict from making and receiving calls with your handset. For this function, you need the barring password, which you can obtain from 3 Customer Service.

Voice calls

The following options are available:

- **All outgoing:** Calls cannot be made.
- **Outgoing international:** International calls cannot be made.
- **Outgoing international calls except home country:** When abroad, calls can be made only to numbers within the current country and to your home country, which is where your home network provider is located.

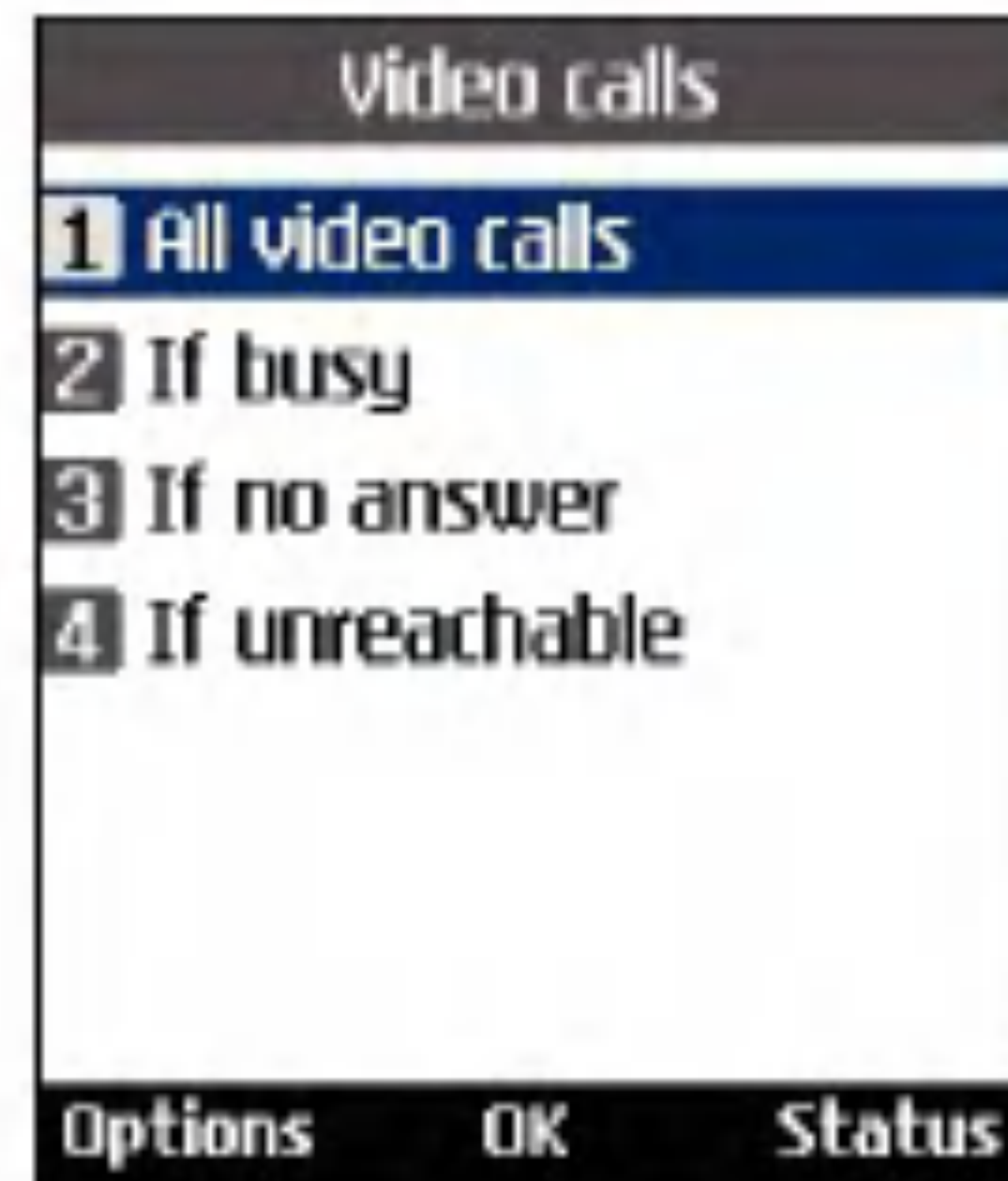

- **All incoming:** Calls cannot be received.
- **Incoming when abroad:** Calls cannot be received when you are using your handset outside your home service area.

Video calls

The following options are available:

- **All outgoing:** Calls cannot be made.
- **Outgoing international:** International calls cannot be made.
- **Outgoing international calls except home country:** When abroad, calls can be made only to numbers within the current country

Calling

and to your home country, which is where your home network provider is located.

- All incoming: Calls cannot be received.
- Incoming when abroad: Calls cannot be received when you are using your handset outside your home service area.

Deactivate all

All call barring settings are deactivated; calls can be made and received normally.

Fixed dial numbers

You can fix dialling to specified phone numbers only. This information is saved on the USIM card. You must enter your PIN2 code for authentication.

- On: Enables Fixed Dial Numbers.
- Off: Disables Fixed Dial Numbers.
- Number list: You can view and edit the Fixed Dial Number list.

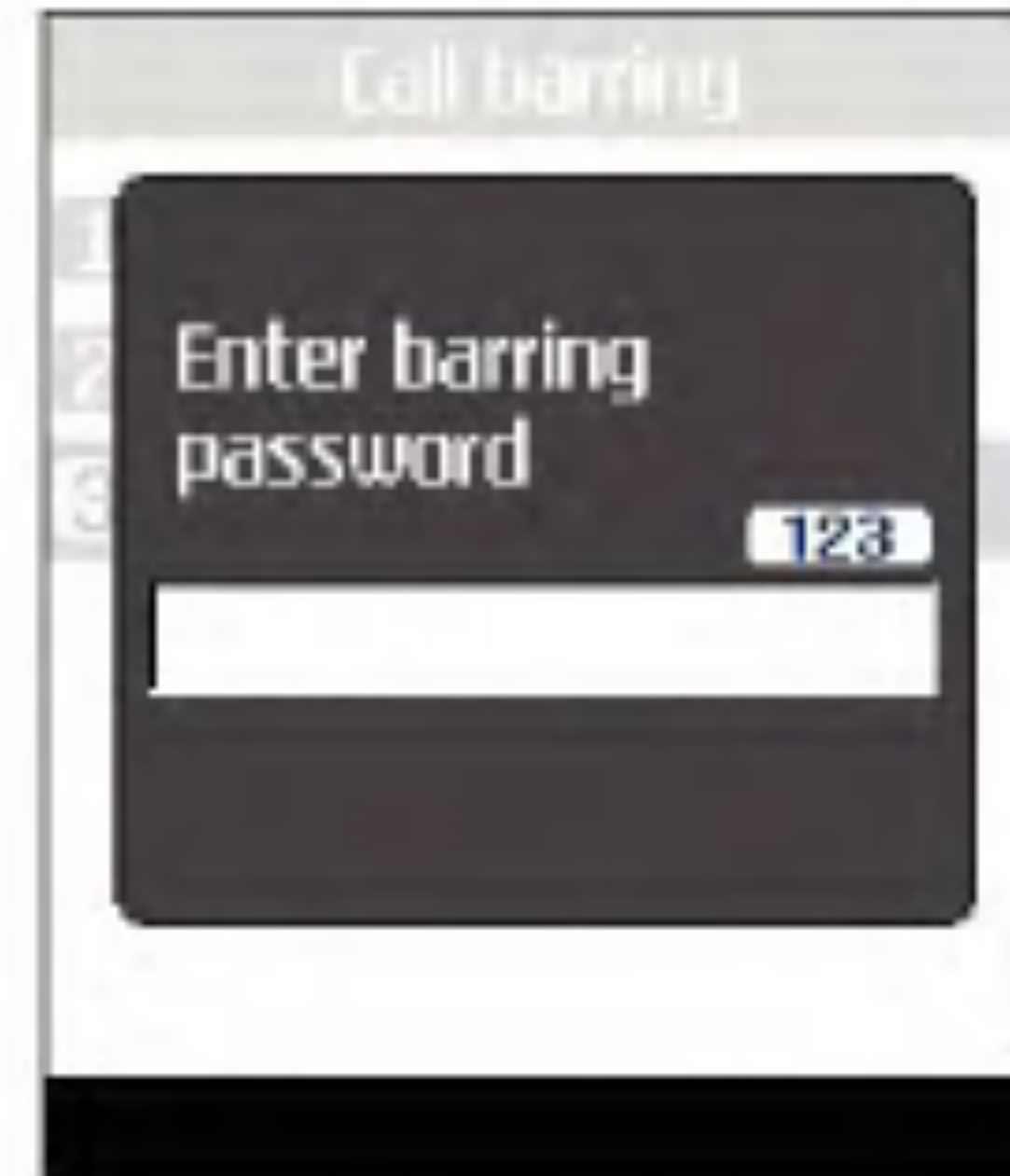

Call waiting

The network will notify you of a new incoming call while you have a call in progress. Select Activate to request the network to activate call waiting, Deactivate to request the network to deactivate call waiting, or View status, to check if the function is active or not.

Settings

Call reject

This menu allows you to enable or disable rejection of all calls or calls categorized as Unregistered, Contacts or Groups.

■ Reject On/Off

To Enable or Disable the Call Reject

■ Reject list

To select the category of call reject numbers. You can select any of the following categories:

- **All Calls**

If this category is selected, all calls will be rejected

- **Contacts**

If this category is selected, all numbers in contacts list will be rejected

- **Groups**

If this category is selected, all numbers belonging to the selected groups will be rejected.

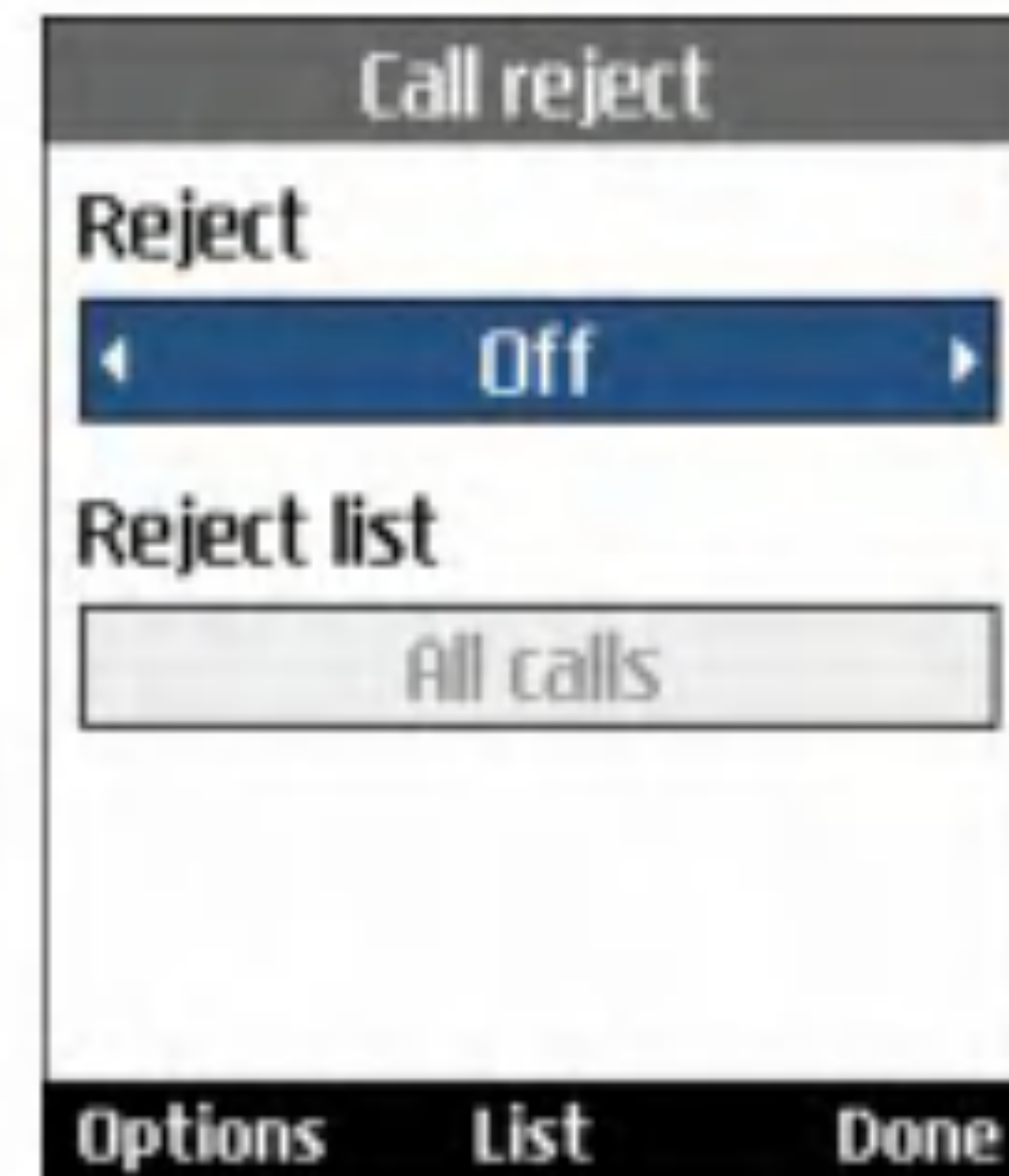

- **Unregistered**

If this category is selected, all un-registered numbers will be rejected.

■ Reject group

If the Reject Category 'Groups' is selected from the Reject List, the group, which has to be rejected, can be selected here.

All the available groups will be listed here. Up to three groups can be selected for rejection.

Press the right soft key [Done] after configuring the Call rejection to save the changes and go back to previous menu.

Calling

Send my number



This network service allows you to set your phone number to be displayed (**On**) or hidden (**Off**) from the person whom you are calling. Select **Set by network** to reset the handset to the setting that you have agreed upon with 3 Customer Service.

Auto redial

The menu enables you to configure the auto redial function when a call attempt has failed.

Answer mode

Allows you to determine when to answer the handset.

- Press send key: You can answer an incoming call by only pressing the  key.
- Press any key: You can answer an incoming call by pressing any key, except the  key, soft keys and side keys.
- Open flip: This option allows you to answer a call simply by opening the flip.

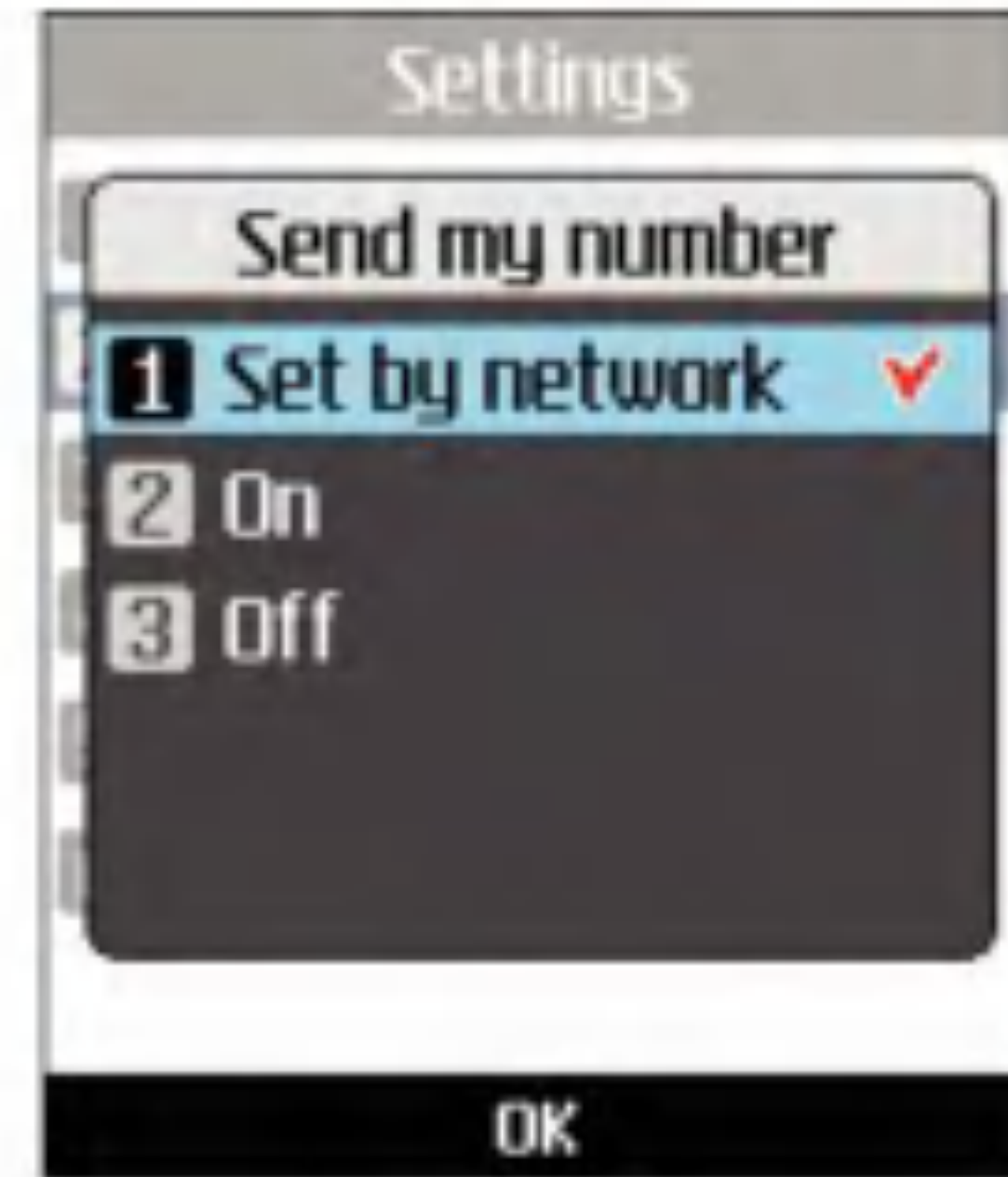

Minute minder

This function sounds an alert notification every 1 minute after call connection.

And so on...

Troubleshooting

Please check to see if any problems you have encountered with the phone are described in this section before calling 3 Customer Service.

Q How do I view the list of outgoing calls, incoming calls and missed calls?

A Press the  key.

Q Why is the connection inconsistent or not audible in certain areas?

A When frequency environment is unstable in a certain area, connection may be inconsistent and not audible. Relocate to another area and try again.

Q Why does the display not turn on?

A Remove and insert the battery, then attempt to power-on. If there is no change, fully charge the battery and try again.

Q Why is there an echo when a connection is made with certain telephones in a certain area?

A This is called the 'Echo Phenomenon', where it occurs if connection volume is too high or caused by special properties (semi electronic telephone exchange) of the equipment on the other end.

Q Why does the handset heat up?

A The phone may get hot when there is a very long call duration or when games are played or when using the browser. This has no effect upon the life of the product or performance.

Q Why is there no ringtone, but only a blinking LCD screen?

A Phone may be set to 'Vibrate only' or in 'Silent' mode. In the Profiles menu, please select 'Normal' or 'Outdoor'.

Q Why does the battery life get shorter in standby mode?

A The battery is worn out. As time passes, the battery life gradually becomes shorter. If the battery lasts about half the amount of time as when first purchased, it's time to purchase a new battery.

Q Why does the battery run out so quickly during normal use?

A It is due to the user environment or a large number of calls or weak signal.

Q Why is no number dialed when you recall a Contacts entry?

A Check that the number has been stored correctly by using the Contacts feature. Re-store them, if necessary.

Q Incoming calls do-not reach me.

A Is your phone switched on ( pressed for more than three seconds)? Are you accessing the right cellular network? Or, you may have set an incoming call barring option.

Q I cannot find the lock, PIN, or PUK code. What is my PIN?

A The default lock code is '0000'. If you forget or lose the lock code, contact your phone dealer. If you forget or lose a PIN or PUK code, or if you have not received such a code, contact 3 Customer Services.

Q What happens to the handset if it is dropped?

A The handset could power off or reset, but this does not necessarily imply any permanent damage.

Accessories

Charger

This adapter allows you to charge the battery. It supports standard Europe/Australia/U.K. and Hongkong (100-240 Volt 50/60Hz outlets).

It takes 3.5 hours to charge a completely discharged battery.



Europe



Australia



U.K and Hongkong

Headset

Connects to your phone, allowing hands-free operation. Includes earpiece, microphone, and integrated call answer/termination button.

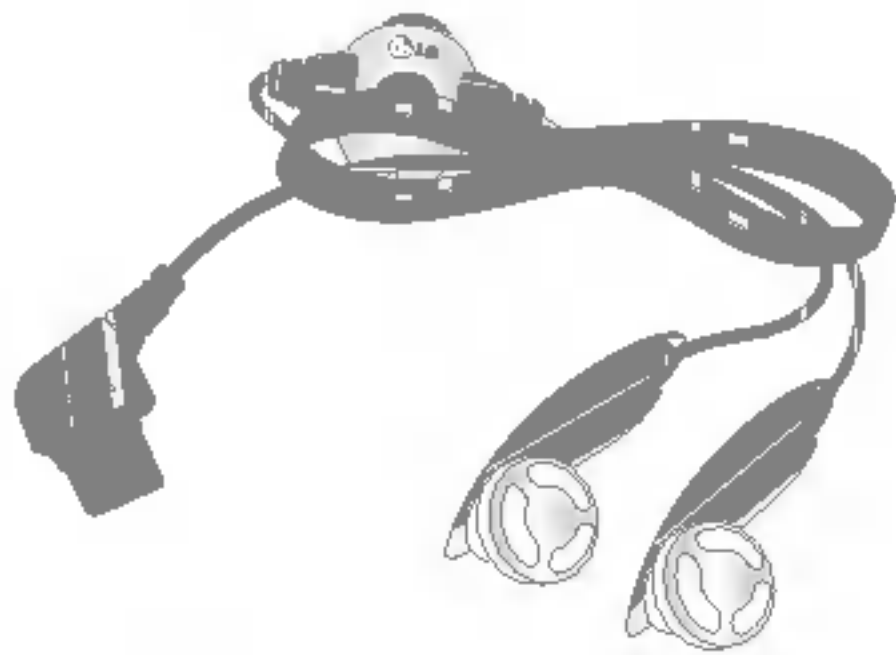

USB cable

Connects your phone to a PC.



Hand strap



Battery



Glossary

2G

Second Generation wireless communication system. 2G system supports low quality voice and low-rate packet-data service. 2G refers to GSM in European countries, and CDMA in America.

3G

Third Generation wireless communication system. 3G means next generation wireless communication system developed based on the second generation wireless communication systems. 3G system supports real-time communication service and high-rate packet-data service. 3G refers to UMTS developed based on GSM in European countries,

Access point

Access point refers to a point through which users can connect to the network so that the users can use the network services.

AMR

Adaptive Multirate codec. A voice codec developed by ETSI for GSM. AMR supports 8 coding rates (from 4.75 to 12.2Kbps) so as to adaptively provide the quality of voice service in various radio channel conditions.

Download

Download means transmitting files from one computer system to another. Downloading usually means transmitting files from a big system to a small system.

Java™

Programming language generating applications that can run on all hardware platforms, whether small, medium or large, without modification. It has been promoted for and geared heavily to the Web, both for public Web sites and Intranets. When a Java program runs from a Web page, it is called a Java applet. When it is run on a mobile phone or pager, it is called a MIDlet.

Line Identification Services (Caller ID)

Service allowing subscribers to view or block the telephone numbers of callers.

MIDI

Musical Instrument Digital Interface. A file format to save digitized musical instrumental data. The original meaning of MIDI, or Music Instrument Digital Interface is a protocol to exchange data between a computer and electric instruments.

MMS (Multimedia Message Service)

A message service for the handset environment, standardized by the WAP Forum and the 3rd Generation Partnership Program (3GPP). For phone users, MMS is similar to Short Message Service (SMS)-it provides automatic, immediatedelivery of user-created content from phone to phone. The message addressing used is primarily phone numbers, thus the traffic goes from phone to phone. MMS also provides support for e-mail addressing, so that messages can also be sent by email. In addition to the text content of SMS, MMS messages can contain still images, voice

or audio clips, and later also video clips and presentation information.

MP3

Moving Picture Experts Group Layer-3 Audio. A file format to provide high-quality audio whose quality is equal to that of CD. MP3 is a digital audio standard developed by MPEG, or Moving Picture Experts Group and is widely used for digital audio files.

MPEG4

Motion Picture Experts Group 4. A digital video standard developed by MPEG, or Moving Picture Experts Group. MPEG4 compresses video data so that a large video file can be transmitted, and saved more easily. MPEG4 is suitable especially for mobile environment.

Multimedia

Multimedia means media that include various media data such as voice, character string, image, and video data. Currently, the meaning of multimedia includes services provided through multimedia.

Glossary

Multiparty Calls

Ability to establish a conference call involving up to five additional parties.

Roaming

Use of your phone when you are outside your home area (when traveling for example).

SDN (Service Dial Number)

Telephone numbers supplied by your network provider and giving access to special services, such as voice mail, directory inquiries, customer support and emergency services.

SMTP

Simple Mail Transfer Protocol. A protocol to transfer e-mails between computers over the Internet. SMTP defines the format of control messages between computers, and interaction procedures between them to send e-mails.

Quick play

Quick play means a new type of service that enables users to listen to an audio or watch video without downloading complete audio or video file so that contents providers can provide audio or video data such as movie or news over the network in real-time on users' demand.

Sync

Sync means synchronizing PIM (Personal Information Management) data such as contact information, schedule, to-do, and memo with a PC or an external server.

UMTS

Universal Mobile Telephony System. UMTS refers to asynchronous 3G wireless technology of WCDMA that is developed based on GSM, the 2G wireless technology.

USB

Universal Serial Bus. A bus type interface that provides fast and flexible connection between devices and a computer.

USIM

Universal Subscriber Identity Module. An IC card used for UMTS the shape of which is the same as that of the SIM card of GSM. USIM is provided by network operator, and carries the authentication and service grade data for the network operator as well as user-specific data.

Video call

A communications service that enables users to talk watching each other over a 64Kbps data channel. Real-time video call service is a new type of service provided by WCDMA wireless communication system that is developed based on GSM+GPRS technology.

Voice mail

Computerised answering service that automatically answers your calls when you are not available, plays a greeting and records a message.

Index

A

Access Codes.....	26
Access points	49
Add new	55, 88
Alarm clock	105
AMR	126
Answer mode.....	120

B

Backlight.....	41
Barring Password.....	27
Battery	21
Battery Information.....	17
Battery cover.....	21
Battery level	23
Browser	54

C

Calculator.....	108
Calendar	96
Call barring.....	117
Call divert.....	116
Call diverting	23
Caller ID.....	127
Camera.....	85
Change codes	50
Charger.....	124
Charging the Battery.....	16
Confirmation tone.....	45

D

Dialled calls	115
Display Information.....	23
Download.....	126

E

Entering Text	29
---------------------	----

F

Fixed dial numbers	118
Light.....	21
Flip tone	45
Font	41

H

Handset lock	50
Headset	125
Home	54

I

Inbox.....	66
------------	----

J

Java	126
------------	-----

K

Key tone	45
Key tone volume	45

L

- Language 51
- Line Identification Services 127

M

- Mailbox..... 68
- Memo 100
- Memo Add..... 100
- Memo Delete 100
- Memory status..... 51, 86
- Message alert..... 44
- Message tone..... 45
- MIDI 127
- Missed calls..... 115
- MMS..... 127
- MP3 127
- MPEG4 127
- Multimedia 84, 127
- Multimedia Message Service..... 127

N

- Network..... 49
- Network selection 49
- New messages 62

O

- Open flip..... 29, 120
- Own number..... 89

P

- PIN code..... 26
- PIN code request 50
- PIN2 code..... 26
- Press any key 120
- Press send key..... 120
- Profiles..... 44, 56
- PUK code 26
- PUK2 code..... 26

Q

- Quick menu 104
- Quick play 128

R

- Received calls..... 115
- Roaming 128
- Roaming service 23

S

- Screen..... 40
- Screen theme 40
- SDN 128
- Search..... 88
- Secret memo 101
- Security..... 50, 56
- Security code 27, 51
- Service dial numbers 89
- Signal Strength 29
- SMTP 128
- Speed dials 88
- Switch on sound 45
- Switch off sound 45

Index

T

- T9 30
- Templates 70
- To do 99
- To do Delete..... 99
- To do Enquiry 99
- Triangle key 20, 25

U

- UMTS 128
- Unit converter 109
- USB 128
- USB cable 125
- USIM 129
- USIM memory..... 52

V

- Vibrate only..... 23, 44
- Video calls..... 114, 116, 117
- Video camera 84, 86
- Video ringtone 44

- Voice call 116, 117
- Voice mail 129
- Voice message 23
- Voice recorder 86
- Voice ringtone..... 44
- Volume 111

W

- World time..... 108

- 3G..... 126
- 3G network 23
- 2G network 23

Declaration of Conformity

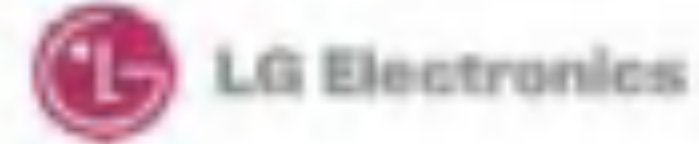

Suppliers Details

Name

LG Electronics Inc

Address

LG Electronics Inc. LG Twin Towers 20,
Yeouido-dong, Yeongdeungpo-gu Seoul, Korea 150-721

Product Details

Product Name

E-GSM 900 / GSM 1800 / GSM 1900 / W-CDMA Terminal Equipment

Model Name

U8360, U8360C

Trade Name

LG

CE 0889

Applicable Standards Details

R&TTE Directive 1999/5/EC

ETSI EN 301 489-01 V1.5.1, ETSI EN 301 489-07 V1.2.1
ETSI EN 301 489-17 V1.2.1, ETSI EN 301 489-24 V1.2.1
ETSI TS 151 010-1 V5.9.0 specified by ETSI EN 301 511 V9.0.2
ETSI TS 134 121 V5.5.0 specified by ETSI EN 301 908-2 V2.2.1
ETSI EN 301 908-1 V2.2.1, ETSI EN 300 328 V1.4.1
EN 50360:2001; EN 50361:2001
EN 60950 : 2001

Supplementary Information

The conformity to above standards is verified by RFI and Phoenix with Certificate No.(SC71090JD02)
It is stated in report (NB71090JD02).

I hereby declare under our sole responsibility
that the product mentioned above to which this declaration
relates complies with the above mentioned
standards and Directives

LG Electronics Inc. Amsterdam Office
Veluwezoom 15, 1327 AE Almere, The Netherlands
Tel : +31 - 36- 547 - 8940, e-mail : seokim @ lge.com

Name

JIn Seog, Kim / Director

Issued Date

25. April. 2005

Signature of representative







