

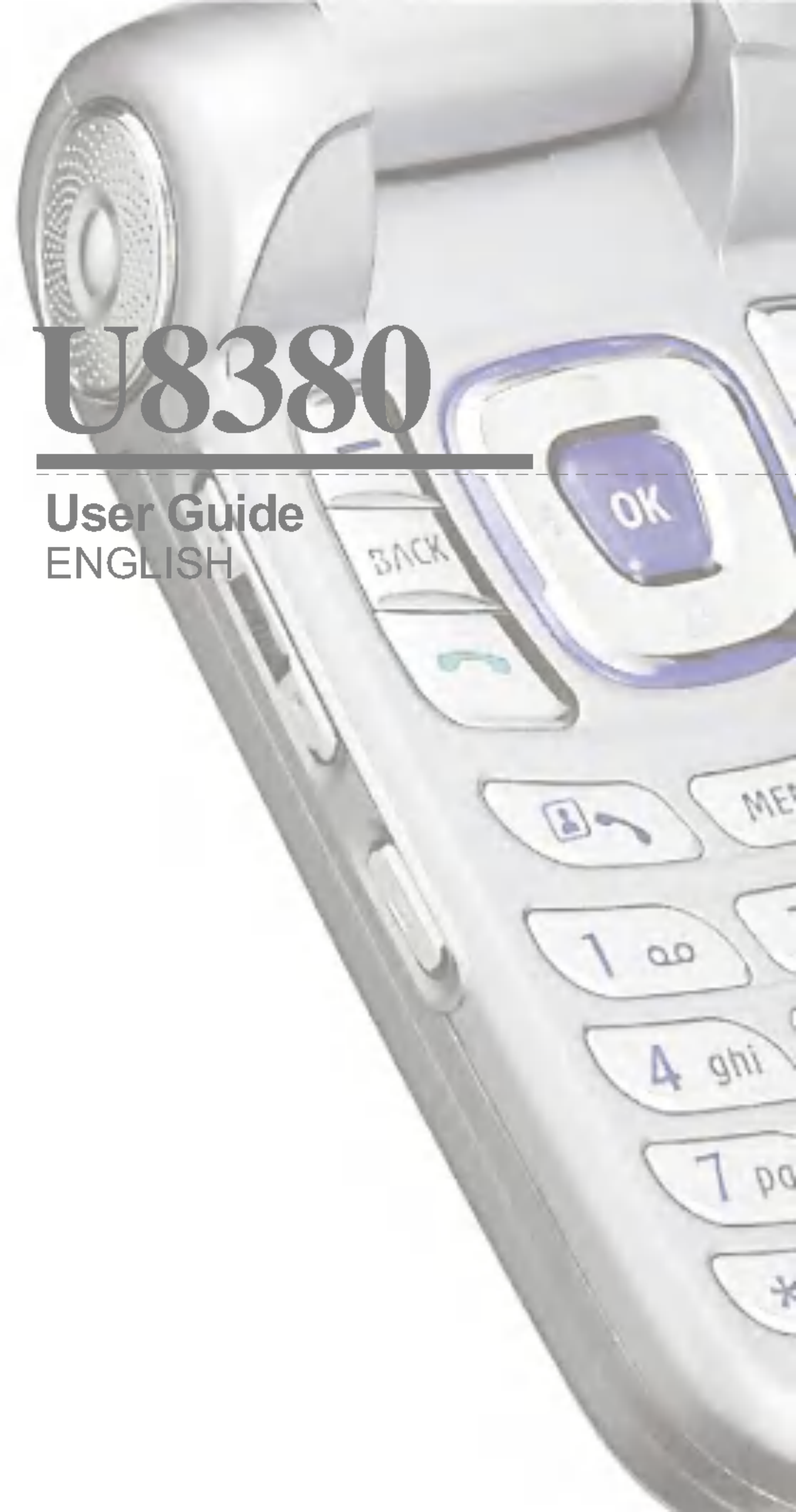

CE 0889



U8380

User Guide
ENGLISH

MANUFACTURER'S WARRANTY

1. WHAT THIS WARRANTY COVERS:

LG offers you a warranty that the enclosed Product and its enclosed accessories will be free from defects in material and workmanship according to the following terms and conditions:

- (1) The warranty for the Product is for ONE (1) year beginning on the date of purchase of the Product.
- (2) The warranty extends only to the original consumer purchaser of the Product ("Customer") and is not assignable or transferable to any subsequent customer. LG offers a warranty for genuine LG battery packs, extending SIX (6) months from the date of purchase.
- (3) This warranty is good only to the Customer during the warranty period as long as it is in AUSTRALIA.
- (4) During the warranty period, any defective LG Product or part will be repaired or replaced by LG or its authorised service centre, at LG's option, with new or factory rebuilt replacement items. LG or the authorised service centre will return the Product to the Customer in working condition. No charge for either parts or labour in repair or replacement of the Product will be incurred by the Customer. If parts, boards or equipment are replaced, they shall become the property of LG.
- (5) Upon request from LG, the Customer must provide LG with proof of the date of purchase.
- (6) The Customer will bear the cost of transporting, delivering and handling the Product to and from LG or its authorised service centre.
- (7) The benefits available from this warranty are in addition to all applicable statutory rights.

2. WHAT THIS WARRANTY DOES NOT COVER:

- (1) Defects or damage resulting from use of the Product in other than its normal and customary manner.
- (2) Defects or damage from abnormal use, abnormal conditions, improper storage, exposure to moisture or dampness, unauthorised modifications, unauthorised connections, unauthorised repair, misuse, neglect, abuse, accident, alteration, improper installation, or other acts which are not the fault of LG, including damage caused by shipping, blown fuses, spills of food or liquid.
- (3) Breakage or damage to antennas, unless caused directly by defects in material or workmanship.
- (4) If the Customer does not notify LG of the alleged defect or malfunction of the Product during the applicable warranty period, the Customer shall have no coverage or benefits under this warranty.
- (5) Products which have had the serial number removed or made illegible.
- (6) If the battery short circuits or the seals of the battery are broken or show evidence of tampering, or the battery was used in equipment in a manner other than that which has been specified, the Customer shall have no coverage or benefits under this warranty.

- (7) Damage resulting from use of non-LG approved accessories.
- (8) All plastic surfaces and all other externally exposed parts that are scratched or damaged due to normal use.
- (9) Products operated outside published maximum ratings.
- (10) Products used or obtained in a rental program.
- (11) Consumables (such as fuses.)
- (12) Defects or damage resulting from breakage of or tampering with the LCD screen.
- (13) Where applicable, Products that have been subject to an unauthorised removal or deactivation of the network operator lock function.

3. STATEMENT

Except for those terms that cannot by law be excluded, all terms other than those expressly contained in this warranty statement are excluded. To the extent permitted by law, LG excludes all liability (whether in contract, tort or otherwise) for any consequential, special, incidental or indirect loss or damage including loss of profit, loss or impairment of privacy of conversations, work stoppage or loss or impairment of data arising out of the use or inability to use the Product.

4. HOW TO GET WARRANTY SERVICE:

To obtain information regarding warranty service, please call the following telephone number from anywhere in AUSTRALIA:

LG Electronics Australia Pty Ltd

2 Wonderland Drive

Eastern Creek NSW 2766

PO Box 212

HORSLEY PARK NSW 2175

Tel: 1800-638-080 Fax: 02-8805-4201

 **LG Electronics Australia Pty Ltd.**

Welcome to your LG U8380 handset

User guides can be daunting things, can't they?
But don't worry, we've made this one as
simple as possible.



Your guide is designed to do two things.

First, there's an explanation on how to use your new LG U8380, so finding your way around the handset will soon become the second nature.

Then there's an introduction to the wide range of services offered, to make sure you get the best from them. If all you want to do is power up and get going, that's fine.

Emergency Services and Safety Precautions	10	Making and Answering calls	45
Getting Started	31	Making and Answering a video call.....	45
Using the Battery, Charger and USIM Card	31	Making a voice/video call.....	46
Installing the Battery.....	31	Making a voice/video call from Contacts	46
Removing the Battery.....	32	Making International Calls	46
Charging the Battery	33	Adjusting the Volume	47
Disconnecting the Charger.....	34	Answering a Call.....	47
Battery Information and care.....	35	Signal Strength.....	47
Installing the USIM Card	36	Entering Text	47
		Changing the Text Input Mode.....	48
Getting to know your LG U8380	37	Using the T9 Mode.....	49
Familiarise yourself with its features	37	Using the ABC Mode.....	49
Your handset's home screen	39	Using the 123(Numbers) Mode	50
Display Information	40	Using the Symbol Mode.....	50
Your handset's keys and navigation	41	Character chart.....	51
Function of keys when phone is idle	42		
		Menu tree	52
General Functions	43	Screen	58
Turning your handset on	43	Screen theme	58
Turning your handset off	43	Home screen	58
Access Codes	43	Outgoing call	58
PIN code (4 to 8 digits).....	43	Sending message	58
PIN2 code (4 to 8 digits).....	43	Switch on.....	58
PUK code (4 to 8 digits)	43	Switch Off.....	58
PUK2 code (4 to 8 digits)	43		
Security code (4 to 8 digits).....	44	Front screen theme	58
		Home screen	58
Barring Password	44	Outgoing call	59

Menu style	59	Reserved memory	70
Font	59	USIM memory	70
Backlight	59	External Memory	70
Handset theme	60	Handset information	70
Greeting message	60	Reset settings	70
Profiles	62	Browser	72
Settings	66	Home	72
Date & time	66	Bookmarks	73
Time.....	66	Connect.....	73
Date	66	Send as message.....	73
Auto update date/time	66	Add new	73
Daylight saving	67	Edit	73
 		Mark/Unmark.....	73
Home screen softkeys	67	Delete	73
Network	67	Saved pages	73
Network selection.....	67	Go to URL	73
Preferred list	67	 	
 		Security	74
Access points	67	Settings	74
Security	68	Profiles	74
PIN code request	68	Character encoding.....	74
Handset lock	68	Scrolling control	74
Change codes	68	Show Image.....	74
 		Cache	75
Language	69	Cookies	75
Memory status	69	Clear cache	75
Common memory	70	Clear cookie	75

Messages	80	Video camera	102
New message	80	Camera	103
Text message	80	Voice recorder	104
Multimedia message	80	Play lists	104
Email.....	83	Settings	104
		Video camera	104
Inbox	84	Camera	104
Mailbox	86	Voice recorder	104
Drafts	87	Memory status	104
Sent items	87		
Templates	88	Contacts	106
Settings	88	Add new	106
Text message	88	Search	106
Multimedia message	88	Speed dials	106
Email	90	Group	107
Videomail	90	Service dial numbers	107
Voicemail	91	Own number	107
ExpressLink	91	Settings	107
Info.Service	91	Display data	107
		Show image/avatar	107
My stuff	94	Copy all	107
Images	94	Move all	108
Videos	95	Clear contacts	108
Sounds	98		
Applications	100	Applications	110
External memory	100	My applications	110
		Download applications	110
Multimedia	102	Settings	110

Organiser	114	Surface	128
Calendar	114	Length	128
To do	117	Weight	128
Memo	118	Temperature	129
Saved Memo's	118	Volume	129
Memo Add.....	118	Velocity	129
Memo Lock/Unlock	118		
Memo Edit	118	Calling	132
Memo Delete	118	Video calls	132
		My picture size	132
Secret memo	119	My picture position	132
Date finder	119	Hide my picture	132
Dateulator	119	Mirror	132
Settings	120	Substitute Picture	132
Calendar	120		
Memory info.	120	Call history	132
Clear all	120	Missed calls.....	133
		Received calls	133
Tools	122	Dialled calls	133
Quick menu	122	All calls	133
Alarm clock	123		
Connectivity	124	Call duration	133
Bluetooth.....	124	Last call	133
Server synchronisation.....	125	Received calls	133
Calculator	126	Dialled calls	134
World time	127	All calls	134
Unit converter	127		
Currency	127	Call costs	134

Call divert	134
Voice calls	134
Video calls	135
All fax calls.....	135
Call barring	135
Voice calls	135
Video calls	136
Deactivate all	136
Fixed dial numbers	136
Call waiting	136
Settings	137
Call reject.....	137
Send my number	138
Auto redial	138
Answer mode	138
Minute minder	138
Troubleshooting	140
Accessories	142
Glossary	144
Index	148



Guidelines for safe and efficient use

Read these simple guidelines. Breaking the rules may be dangerous or illegal.
Further detailed information is given in this manual.

Emergency Services and Safety Precautions

For Your Safety

Read these simple guidelines. Breaking the rules may be dangerous or illegal. Further detailed information is given in this manual.

Warning

- Mobile Phones must be switched off at all times in an aircraft.
- Do not hold the phone in your hand while driving.
- Do not use your phone near petrol stations, fuel depots, chemical plants or blasting operations.
- For your safety, use ONLY specified ORIGINAL batteries and chargers.
- Do not handle the phone with wet hands while it is being charged. It may cause an electric shock or seriously damage your phone.
- Keep the phone in a safe place out of children's reach. It includes small parts which if detached may cause a choking hazard.

Caution

- Switch off the phone in any area where required by special regulations. For example, do not use your phone in hospitals or it may affect sensitive medical equipment.
- Emergency call may not be available under all cellular networks. Therefore, you should never depend solely on the phone for emergency calls.
- Only use ORIGINAL accessories to avoid damage to your phone.
- All radio transmitters carry risks of interference with electronics in close proximity. Minor interference may affect TVs, radios, PCs, etc.
- Batteries should be disposed of in accordance with relevant legislation.
- Do not dismantle the phone or battery.

Exposure to radio frequency energy

Radio wave exposure and Specific Absorption Rate (SAR) information

- This handset model U8380 has been designed to comply with safety requirements for exposure to radio waves. This requirement is based on scientific guidelines that include safety margins designed to assure the safety of all persons, regardless of age and health
- The radio wave exposure guidelines employ a unit of measurement known as the Specific Absorption Rate, or SAR. Tests for SAR are conducted using a standardized method with the phone transmitting at its highest certified power level in all used frequency bands
- While there may be differences between the SAR levels of various LG phone models, they are all designed to meet the relevant guidelines for exposure to radio waves
- The SAR limit recommended by the International Commission on Non-Ionizing Radiation Protection (ICNIRP), is 2W/kg averaged over ten (10) gramme of tissue
- The highest SAR value for this model phone tested by DASY3 for use at the ear is 0.671 W/kg (10g)
- The SAR limit recommended by the Institute of Electrical and Electronics Engineers (IEEE), which is 1.6 W/kg averaged over one (1) gramme of tissue (for example USA, Canada, Australia and Taiwan).

Emergency Services and Safety Precautions

FCC Part 15 Class B Compliance

This device and its accessories comply with part 15 of FCC rules. Operation is subject to the following two conditions: (1) This device and its accessories may not cause harmful interference, and (2) this device and its accessories must accept any interference received, including interference that causes undesired operation.

FCC RF Exposure Information

WARNING! Read this information before operating the phone.

In August 1996, the Federal Communications Commission (FCC) of the United States, with its action in Report and Order FCC 96-326, adopted an updated safety standard for human exposure to radio frequency (RF) electromagnetic energy emitted by FCC regulated transmitters. Those guidelines are consistent with the safety standard previously set by both U.S. and international standards bodies. The design of this phone complies with the FCC guidelines and these international standards.

Bodily Contact During Operation

This device was tested for typical use with the back of the phone kept 3/4 inches (2 cm) from the body. To comply with FCC RF exposure requirements, a minimum separation distance of 3/4 inches (2 cm) must be maintained between the user's body and the back of the phone, including the antenna, whether extended or retracted. Third-party belt-clips, holsters, and similar accessories containing metallic components should not be used. Avoid the use of accessories that cannot maintain 3/4 inches (2 cm) distance between the user's body and the back of the phone and have not been tested for compliance with FCC RF exposure limits.

Vehicle-Mounted External Antenna

(Optional, if available.)

A minimum distance of 8 inches (20 cm) must be maintained between the user / bystander and the vehicle-mounted external antenna to satisfy FCC RF exposure requirements. For more information about RF exposure, visit the FCC website at www.fcc.gov.

Caution

Use only the supplied and approved antenna. Use of unauthorized antennas or modifications could impair call quality, damage the phone, void your warranty and/or result in violation of FCC regulations.

Do not use the phone with a damaged antenna. If a damaged antenna comes into contact with the skin a minor burn may result. Contact your local dealer for a replacement of antenna.

TIA Safety Information

The following is the complete TIA Safety Information for wireless handheld phones.

Exposure to Radio Frequency Signal

Your wireless handheld portable phone is a low power radio transmitter and receiver. When it is ON, it receives and also sends out radio frequency (RF) signals. In August, 1996, the Federal Communications Commissions (FCC) adopted RF exposure guidelines with safety levels for handheld wireless phones. Those guidelines are consistent with the safety standards previously set by both U.S. and international standards bodies:

ANSI C95.1 (1992) *

NCRP Report 86 (1986)

ICNIRP (1996)

American National Standards Institute; National Council on Radiation Protection and Measurements; International Commission on Non-Ionizing Radiation Protection

Those standards were based on comprehensive and periodic evaluations of the relevant scientific literature. For example, over 120 scientists, engineers, and physicians from universities, government health agencies, and industry reviewed the available body of research to develop the ANSI Standard (C95.1).

The design of your phone complies with the FCC guidelines (and those standards).

Antenna Care

Use only the supplied or an approved replacement antenna. Unauthorized antennas, modifications, or attachments could damage the phone and may violate FCC regulations.

Emergency Services and Safety Precautions

Phone Operation

NORMAL POSITION: Hold the phone as you would any other telephone with the antenna pointed up and over your shoulder.

Tips on Efficient Operation

For your phone to operate most efficiently: Do not touch the antenna unnecessarily when the phone is in use. Contact with the antenna affects call quality and may cause the phone to operate at a higher power level than otherwise needed.

Driving

Check the laws and regulations on the use of wireless phones in the areas where you drive and always obey them. Also, if using your phone while driving, please observe the following:

- Give full attention to driving - driving safely is your first responsibility;
- Use hands-free operation, if available;
- Pull off the road and park before making or answering a call if driving conditions or the law so require.

Electronic Devices

Most modern electronic equipment is shielded from RF signals. However, certain electronic equipment may not be shielded against the RF signals from your wireless phone.

Pacemakers

The Health Industry Manufacturers Association recommends that a minimum separation of six (6) inches be maintained between a handheld wireless phone and a pacemaker to avoid potential interference with the pacemaker. These recommendations are consistent with the independent research by and recommendations of Wireless Technology Research.

Persons with pacemakers:

- Should ALWAYS keep the phone more than six (6) inches from their pacemaker when the phone is turned ON;
- Should not carry the phone in a breast pocket;
- Should use the ear opposite the pacemaker to minimize the potential for interference;

- Should turn the phone OFF immediately if there is any reason to suspect that interference is taking place.

Hearing Aids

Some digital wireless phones may interfere with some hearing aids. In the event of such interference, you may want to consult your service provider (or call the customer service line to discuss alternatives.) Optional for each phone manufacturer.

Other Medical Devices

If you use any other personal medical device, consult the manufacturer of your device to determine if it is adequately shielded from external RF energy. Your physician may be able to assist you in obtaining this information.

Health Care Facilities

Turn your phone OFF in health care facilities when any regulations posted in these areas instruct you to do so. Hospitals or health care facilities may use equipment that could be sensitive to external RF energy.

Vehicles

RF signals may affect improperly installed or inadequately shielded electronic systems in motor vehicles. Check with the manufacturer or its representative regarding your vehicle. You should also consult the manufacturer of any equipment that has been added to your vehicle.

Posted Facilities

Turn your phone OFF in any facility where posted notices so require.

Aircraft

FCC regulations prohibit using your phone while in the air. Switch OFF your phone before boarding an aircraft.

Blasting Areas

To avoid interfering with blasting operations, turn your phone OFF when in a “blasting area” or in areas posted: “Turn off two-way radio”. Obey all signs and instructions.

Emergency Services and Safety Precautions

Potentially Explosive Atmosphere

Turn your phone OFF when in any area with a potentially explosive atmosphere and obey all signs and instructions. Sparks in such areas could cause an explosion or fire resulting in bodily injury or even death.

Areas with a potentially explosive atmosphere are often, but not always marked clearly.

Potential areas may include: fueling areas (such as gasoline stations); below deck on boats; fuel or chemical transfer or storage facilities; vehicles using liquefied petroleum gas (such as propane or butane); areas where the air contains chemicals or particles (such as grain, dust, or metal powders); and any other area where you would normally be advised to turn off your vehicle engine.

For Vehicles Equipped with an Air Bag

An air bag inflates with great force. DO NOT place objects, including either installed or portable wireless equipment, in the area over the air bag or in the air bag deployment area. If in-vehicle wireless equipment is improperly installed and the air bag inflates, serious injury could result.

Adapter and Charger Safety

- The adapter and charger are intended for indoor use only.
- Do not expose the adapter or battery pack charger to direct sunlight or use it in places with high humidity, such as a bathroom.
- Insert the battery pack charger vertically to wall power outlet.
- If you use the battery pack charger out of USA, use an attachment plug adaptor for the proper configuration.

Battery Information and Care

- Please dispose of your battery properly or take it to your local wireless carrier for recycling.
- Do not dispose of your battery in fire or with hazardous or flammable materials.
- Never store your phone in temperatures less than -4° F or greater than 122° F.
- Never use an unapproved battery since this could damage the phone and/or battery and could cause the battery to explode.

- The battery does not need to be fully discharged before recharging.
- Use only LG-approved chargers specific to your phone model since they are designed to maximize battery life.
- Do not disassemble or short-circuit the battery.
- Keep the battery's metal contacts clean.
- Replace the battery when it no longer provides acceptable performance. The battery can be recharged several hundred times before replacement.
- Recharge the battery after long periods of non-use to maximize battery life.
- Battery life will vary due to usage patterns and environmental conditions.
- Use of extended backlighting, MiniBrowser, and data connectivity kits affect battery life and talk/standby times.

Safety Information

Please read and observe the following information for safe and proper use

of your phone and to prevent damage. Also, keep the user's guide in an accessible place at all the times after reading it.

Explosion, Shock, and Fire Hazards

- Unplug the power cord and charger during lightning storms to avoid electric shock or fire.
- Make sure that no sharp-edged items such as animal's teeth, nails, come into contact with the battery. There is a risk of this causing a fire.
- Do not use harsh chemicals (such as alcohol, benzene, thinners, etc.) or detergents to clean your phone. There is a risk of this causing a fire.
- When riding in a car, do not leave your phone or set up the hands-free kit near to the air bag. If wireless equipment is improperly installed and the air bag is activated, you may be seriously injured.

Emergency Services and Safety Precautions

- Do not handle the phone with wet hands while it is being charged. It may cause an electric shock or seriously damage your phone.
- Do not drop, strike, or shake your phone severely. Such actions may harm the internal circuit boards of the phone.
- Be careful that children do not swallow any parts such as rubber plugs (earphone, connection parts of the phone, etc.). This could cause asphyxiation or suffocation.
- Do not use your phone in high explosive areas as the phone may generate sparks.
- Do not put your phone in a place subject to excessive dust and keep the minimum required distance between the power cord and heat sources.
- Unplug the power cord prior to cleaning your phone, and clean the power plug pin when it is dirty.
- Do not damage the power cord by bending, twisting, pulling, or heating. Do not use the plug if it is loose as it may cause a fire or electric shock.
- When using the power plug, ensure that it is firmly connected. If it is not, it may cause excessive heat or fire.
- Do not place any heavy items on the power cord. Do not allow the power cord to be crimped as it may cause fire or electric shock.
- Do not disassemble the phone.
- Do not place or answer calls while charging the phone as it may short-circuit the phone and/or cause electric shock or fire.
- If you put your phone in a pocket or bag without covering the receptacle of the phone (power plug pin), metallic articles (such as a coin, paperclip or pen) may short-circuit the phone. Always cover the receptacle when not in use.
- Do not short-circuit the battery. Metallic articles such as a coin, paperclip or pen in your pocket or bag may short-circuit the + and – terminals of the battery (metal strips on the battery) upon moving. Short-circuit of the terminal may damage the battery and cause an explosion.
- Never place your phone in a microwave oven as it will cause the battery to explode.

General Warnings and Cautions

- Only use the batteries, antennas, and chargers provided by LG. The warranty will not be applied to products provided by other suppliers.
- Store the battery in a place out of reach of children.
- Using a damaged battery or placing a battery in your mouth may cause serious injury.
- Do not place items containing magnetic components such as a credit card, phone card, bank book or subway ticket near your phone. The magnetism of the phone may damage the data stored in the magnetic strip.
- Do not hold or let the antenna come in contact with your body during a call.
- Talking on your phone for a long period of time may reduce call quality due to heat generated during use.
- When the phone is not used for a long period time, store it in a safe place with the power cord unplugged.
- Using the phone in proximity to receiving equipment (i.e., TV or radio) may cause interference to the phone.
- Only authorized personnel should service the phone and its accessories. Faulty installation or service may result in accidents and consequently invalidate the warranty.
- Do not use the phone if the antenna is damaged. If a damaged antenna contacts skin, it may cause a slight burn. Please contact an LG Authorized Service Center to replace the damaged antenna.
- Do not use the phone in areas where its use is prohibited. (For example: aircraft).
- Do not immerse your phone in water. If this happens, turn it off immediately and remove the battery. If the phone does not work, take it to an LG Authorized Service Center.
- The power cord on this product will expose you to lead, a chemical known to the State of California to cause (cancer, and) birth defects or other reproductive harm. Wash hands after handling.

Emergency Services and Safety Precautions

FDA Consumer Update

The U.S. Food and Drug Administration's Center for Devices and Radiological Health Consumer Update on Mobile Phones:

1. Do wireless phones pose a health hazard?

The available scientific evidence does not show that any health problems are associated with using wireless phones. There is no proof, however, that wireless phones are absolutely safe. Wireless phones emit low levels of radiofrequency energy (RF) in the microwave range while being used. They also emit very low levels of RF when in the standby mode.

Whereas high levels of RF can produce health effects (by heating tissue), exposure to low level RF that does not produce heating effects causes no known adverse health effects. Many studies of low level RF exposures have not found any biological effects. Some studies have suggested that some biological effects may occur, but such findings have not been confirmed by additional research. In some cases, other researchers have had difficulty in

reproducing those studies, or in determining the reasons for inconsistent results.

2. What is the FDA's role concerning the safety of wireless phones?

Under the law, the FDA does not review the safety of radiation-emitting consumer products such as wireless phones before they can be sold, as it does with new drugs or medical devices. However, the agency has authority to take action if wireless phones are shown to emit radiofrequency energy (RF) at a level that is hazardous to the user. In such a case, the FDA could require the manufacturers of wireless phones to notify users of the health hazard and to repair, replace, or recall the phones so that the hazard no longer exists. Although the existing scientific data do not justify FDA regulatory actions, the FDA has urged the wireless phone industry to take a number of steps, including the following:

- Support needed research into possible biological effects of RF of the type emitted by wireless phones;

- Design wireless phones in a way that minimizes any RF exposure to the user that is not necessary for device function; and
- Cooperate in providing users of wireless phones with the best possible information on possible effects of wireless phone use on human health.

The FDA belongs to an interagency working group of the federal agencies that have responsibility for different aspects of RF safety to ensure coordinated efforts at the federal level. The following agencies belong to this working group:

- National Institute for Occupational Safety and Health
- Environmental Protection Agency
- Occupational Safety and Health Administration
- National Telecommunications and Information Administration

The National Institutes of Health participates in some interagency working group activities, as well.

The FDA shares regulatory responsibilities for wireless phones with the Federal Communications Commission (FCC). All phones that are sold in the United States must comply with FCC safety guidelines that limit RF exposure. The FCC relies on the FDA and other health agencies for safety questions about wireless phones.

The FCC also regulates the base stations that the wireless phone networks rely upon. While these base stations operate at higher power than do the wireless phones themselves, the RF exposures that people get from these base stations are typically thousands of times lower than those they can get from wireless phones. Base stations are thus not the subject of the safety questions discussed in this document.

Emergency Services and Safety Precautions

3. What kinds of phones are the subject of this update?

The term “wireless phone” refers here to handheld wireless phones with built-in antennas, often called “cell”, “mobile”, or “PCS” phones. These types of wireless phones can expose the user to measurable radiofrequency energy (RF) because of the short distance between the phone and the user’s head.

These RF exposures are limited by FCC safety guidelines that were developed with the advice of the FDA and other federal health and safety agencies. When the phone is located at greater distances from the user, the exposure to RF is drastically lower because a person's RF exposure decreases rapidly with increasing distance from the source. The so-called “cordless phones,” which have a base unit connected to the telephone wiring in a house, typically operate at far lower power levels, and thus produce RF exposures far below the FCC safety limits.

4. What are the results of the research done already?

The research done thus far has produced

conflicting results, and many studies have suffered from flaws in their research methods. Animal experiments investigating the effects of radiofrequency energy (RF) exposures characteristic of wireless phones have yielded conflicting results that often cannot be repeated in other laboratories. A few animal studies, however, have suggested that low levels of RF could accelerate the development of cancer in laboratory animals. However, many of the studies that showed increased tumor development used animals that had been genetically engineered or treated with cancer-causing chemicals so as to be pre-disposed to develop cancer in the absence of RF exposure. Other studies exposed the animals to RF for up to 22 hours per day. These conditions are not similar to the conditions under which people use wireless phones, so we don’t know with certainty what the results of such studies mean for human health. Three large epidemiology studies have been published since December 2000. Between them, the studies investigated any possible association between the use of wireless phones and primary brain cancer, glioma, meningioma, or acoustic neuroma, tumors of the brain or salivary gland,



leukemia, or other cancers. None of the studies demonstrated the existence of any harmful health effects from wireless phone RF exposures. However, none of the studies can answer questions about long-term exposures, since the average period of phone use in these studies was around three years.

5. What research is needed to decide whether RF exposure from wireless phones poses a health risk?

A combination of laboratory studies and epidemiological studies of people actually using wireless phones would provide some of the data that are needed. Lifetime animal exposure studies could be completed in a few years. However, very large numbers of animals would be needed to provide reliable proof of a cancer promoting effect if one exists. Epidemiological studies can provide data that is directly applicable to human populations, but 10 or more years follow-up may be needed to provide answers about some health effects, such as cancer. This is because the interval between the time of exposure to a cancer-causing agent and the time tumors develop — if they do — may be many, many years. The interpretation of

epidemiological studies is hampered by difficulties in measuring actual RF exposure during day-to-day use of wireless phones. Many factors affect this measurement, such as the angle at which the phone is held, or which model of phone is used.

6. What is the FDA doing to find out more about the possible health effects of wireless phone RF?

The FDA is working with the U.S. National Toxicology Program and with groups of investigators around the world to ensure that high priority animal studies are conducted to address important questions about the effects of exposure to radio frequency energy (RF).

The FDA has been a leading participant in the World Health Organization International Electromagnetic Fields (EMF) Project since its inception in 1996. An influential result of this work has been the development of a detailed agenda of research needs that has driven the establishment of new research programs around the world. The project has also helped develop a series of public information documents on EMF issues. The FDA and the

Emergency Services and Safety Precautions

Cellular Telecommunications & Internet Association (CTIA) have a formal Cooperative Research and Development Agreement (CRADA) to do research on wireless phone safety. The FDA provides the scientific oversight, obtaining input from experts in government, industry, and academic organizations. CTIA-funded research is conducted through contracts with independent investigators. The initial research will include both laboratory studies and studies of wireless phone users. The CRADA will also include a broad assessment of additional research needs in the context of the latest research developments around the world.

7. How can I find out how much radio frequency energy exposure I can get by using my wireless phone?

All phones sold in the United States must comply with Federal Communications Commission (FCC) guidelines that limit radio frequency energy (RF) exposures. The FCC established these guidelines in consultation with the FDA and the other federal health and safety agencies. The FCC limit for RF exposure from wireless telephones is set at a Specific

Absorption Rate (SAR) of 1.6 watts per kilogram (1.6 W/kg). The FCC limit is consistent with the safety standards developed by the Institute of Electrical and Electronic Engineering (IEEE) and the National Council on Radiation Protection and Measurement. The exposure limit takes into consideration the body's ability to remove heat from the tissues that absorb energy from the wireless phone and is set well below levels known to have effects. Manufacturers of wireless phones must report the RF exposure level for each model of phone to the FCC. The FCC website (<http://www.fcc.gov/oet/rfsafety>) gives directions for locating the FCC identification number on your phone so you can find your phone's RF exposure level in the online listing.

8. What has the FDA done to measure the radio frequency energy coming from wireless phones?

The Institute of Electrical and Electronic Engineers (IEEE) is developing a technical standard for measuring the radio frequency energy (RF) exposure from wireless phones and other wireless handsets with the participation and leadership of FDA scientists and engineers.



The standard, “Recommended Practice for Determining the Spatial-Peak Specific Absorption Rate (SAR) in the Human Body Due to Wireless Communications Devices: Experimental Techniques,” sets forth the first consistent test methodology for measuring the rate at which RF is deposited in the heads of wireless phone users. The test method uses a tissue-simulating model of the human head. Standardized SAR test methodology is expected to greatly improve the consistency of measurements made at different laboratories on the same phone. SAR is the measurement of the amount of energy absorbed in tissue, either by the whole body or a small part of the body. It is measured in watts/kg (or milliwatts/g) of matter. This measurement is used to determine whether a wireless phone complies with safety guidelines.

9. What steps can I take to reduce my exposure to radio frequency energy from my wireless phone?

If there is a risk from these products - and at this point we do not know that there is - it is probably very small. But if you are concerned about avoiding even potential risks, you can

take a few simple steps to minimize your exposure to radio frequency energy (RF). Since time is a key factor in how much exposure a person receives, reducing the amount of time spent using a wireless phone will reduce RF exposure. If you must conduct extended conversations by wireless phone every day, you could place more distance between your body and the source of the RF, since the exposure level drops off dramatically with distance. For example, you could use a headset and carry the wireless phone away from your body or use a wireless phone connected to a remote antenna. Again, the scientific data do not demonstrate that wireless phones are harmful. But if you are concerned about the RF exposure from these products, you can use measures like those described above to reduce your RF exposure from wireless phone use.

10. What about children using wireless phones?

The scientific evidence does not show a danger to users of wireless phones, including children and teenagers. If you want to take steps to lower exposure to radio frequency energy (RF),

Emergency Services and Safety Precautions

the measures described above would apply to children and teenagers using wireless phones. Reducing the time of wireless phone use and increasing the distance between the user and the RF source will reduce RF exposure. Some groups sponsored by other national governments have advised that children be discouraged from using wireless phones at all. For example, the government in the United Kingdom distributed leaflets containing such a recommendation in December 2000. They noted that no evidence exists that using a wireless phone causes brain tumors or other ill effects. Their recommendation to limit wireless phone use by children was strictly precautionary; it was not based on scientific evidence that any health hazard exists.

11. What about wireless phone interference with medical equipment?

Radio frequency energy (RF) from wireless phones can interact with some electronic devices. For this reason, the FDA helped develop a detailed test method to measure electromagnetic interference (EMI) of implanted cardiac pacemakers and defibrillators from

wireless telephones. This test method is now part of a standard sponsored by the Association for the Advancement of Medical Instrumentation (AAMI). The final draft, a joint effort by the FDA, medical device manufacturers, and many other groups, was completed in late 2000. This standard will allow manufacturers to ensure that cardiac pacemakers and defibrillators are safe from wireless phone EMI.

The FDA has tested hearing aids for interference from handheld wireless phones and helped develop a voluntary standard sponsored by the Institute of Electrical and Electronic Engineers (IEEE). This standard specifies test methods and performance requirements for hearing aids and wireless phones so that no interference occurs when a person uses a “compatible” phone and a “compatible” hearing aid at the same time. This standard was approved by the IEEE in 2000.

The FDA continues to monitor the use of wireless phones for possible interactions with other medical devices. Should harmful interference be found to occur, the FDA will conduct testing to assess the interference and work to resolve the problem.

12. Where can I find additional information?

For additional information, please refer to the following resources:

FDA web page on wireless phones
(<http://www.fda.gov/cdrh/phones/index.html>)

Federal Communications Commission (FCC) RF Safety Program
(<http://www.fcc.gov/oet/rfsafety>)

International Commission on Non-Ionizing Radiation Protection (<http://www.icnirp.de>)

World Health Organization (WHO) International EMF Project (<http://www.who.int/emf>)

National Radiological Protection Board (UK)
(<http://www.nrpb.org.uk/>)

10 Driver Safety Tips

Your wireless phone gives you the powerful ability to communicate by voice almost anywhere, anytime. An important responsibility accompanies the benefits of wireless phones, one that every user must uphold.

When operating a car, driving is your first responsibility. When using your wireless phone

behind the wheel of a car, practice good common sense and remember the following tips:

1. Get to know your wireless phone and its features such as speed dial and redial. Carefully read your instruction manual and learn to take advantage of valuable features most phones offer, including automatic redial and memory. Also, work to memorize the phone keypad so you can use the speed dial function without taking your attention off the road.
2. When available, use a hands-free device. A number of hands-free wireless phone accessories are readily available today. Whether you choose an installed mounted device for your wireless phone or a speaker phone accessory, take advantage of these devices if available to you.
3. Position your wireless phone within easy reach. Make sure you place your wireless phone within easy reach and where you can reach it without removing your eyes from the road. If you get an incoming call at an inconvenient time, if possible, let your voicemail answer it for you.

Emergency Services and Safety Precautions

4. Suspend conversations during hazardous driving conditions or situations. Let the person you are speaking with know you are driving; if necessary, suspend the call in heavy traffic or hazardous weather conditions. Rain, sleet, snow and ice can be hazardous, but so is heavy traffic. As a driver, your first responsibility is to pay attention to the road.
5. Do not take notes or look up phone numbers while driving. If you are reading an address book or business card, or writing a "to-do" list while driving a car, you are not watching where you are going. It is common sense. Don't get caught in a dangerous situation because you are reading or writing and not paying attention to the road or nearby vehicles.
6. Dial sensibly and assess the traffic; if possible, place calls when you are not moving or before pulling into traffic. Try to plan your calls before you begin your trip or attempt to coincide your calls with times you may be stopped at a stop sign, red light or otherwise stationary. But if you need to dial while driving, follow this simple tip -- dial only a few numbers, check the road and your mirrors, then continue.
7. Do not engage in stressful or emotional conversations that may be distracting. Stressful or emotional conversations and driving do not mix; they are distracting and even dangerous when you are behind the wheel of a car. Make people you are talking with aware you are driving and if necessary, suspend conversations which have the potential to divert your attention from the road.
8. Use your wireless phone to call for help. Your wireless phone is one of the greatest tools you can own to protect yourself and your family in dangerous situations -- with your phone at your side, help is only three numbers away. Dial 000 or other local emergency number in the case of fire, traffic accident, road hazard or medical emergency. Remember, it is a free call on your wireless phone!
9. Use your wireless phone to help others in emergencies. Your wireless phone provides you a perfect opportunity to be a "Good Samaritan" in your community. If you see an



auto accident, crime in progress or other serious emergency where lives are in danger, call 000 or other local emergency number, as you would want others to do for you.

10. Call roadside assistance or a special wireless non-emergency assistance number when necessary. Certain situations you encounter while driving may require attention, but are not urgent enough to merit a call for emergency services. But you can still use your wireless phone to lend a hand. If you see a broken-down vehicle posing no serious hazard, a broken traffic signal, a minor traffic accident where no one appears injured or a vehicle you know to be stolen, call roadside assistance or other special non-emergency wireless number.

For more information, please call to 888-901-SAFE, or visit our website www.wow-com.com

Consumer Information on SAR

(Specific Absorption Rate)

This Model Phone Meets the Government's Requirements for Exposure to Radio Waves.

Your wireless phone is a radio transmitter and receiver. It is designed and manufactured not to exceed the emission limits for exposure to radio frequency (RF) energy set by the Federal Communications Commission of the U.S. Government. These limits are part of comprehensive guidelines and establish permitted levels of RF energy for the general population. The guidelines are based on standards that were developed by independent scientific organizations through periodic and thorough evaluation of scientific studies. The standards include a substantial safety margin designed to assure the safety of all persons, regardless of age and health.

The exposure standard for wireless mobile phones employs a unit of measurement known as the Specific Absorption Rate, or SAR. The SAR limit set by the FCC is 1.6 W/kg. Tests for SAR are conducted using standard operating positions specified by the FCC with the phone transmitting at its highest certified power level in all tested frequency bands. Although SAR is determined at the highest certified power level, the actual SAR level of the phone while operating can be well below the maximum

Emergency Services and Safety Precautions

value. Because the phone is designed to operate at multiple power levels to use only the power required to reach the network, in general, the closer you are to a wireless base station antenna, the lower the power output.

Before a phone model is available for sale to the public, it must be tested and certified to the FCC that it does not exceed the limit established by the government-adopted requirement for safe exposure. The tests are performed in positions and locations (e.g., at the ear and worn on the body) as required by the FCC for each model.

The highest SAR value for this model phone when tested for use at the ear is 0.639 W/kg and when worn on the body, as described in this user guide, is 0.713 W/kg (body-worn measurements differ among phone models, depending upon available accessories and FCC requirements). While there may be differences between SAR levels of various phones and at various positions, they all meet the government requirement for safe exposure.

The FCC has granted an Equipment Authorization for this model phone with all reported SAR levels evaluated as in compliance

with the FCC RF emission guidelines. SAR information on this model phone is on file with the FCC and can be found under the Display Grant section of <http://www.fcc.gov/oet/fccid> after searching on FCC ID BEJU8380.

Additional information on Specific Absorption Rates (SAR) can be found on the Cellular Telecommunications Industry Association (CTIA) website at <http://www.wow-com.com>.

* In the United States and Canada, the SAR limit for mobile phones used by the public is 1.6 watts/kg (W/kg) averaged over one gram of tissue. The standard incorporates a substantial margin of safety to give additional protection for the public and to account for any variations in measurements.

Getting Started

Using the Battery, Charger and USIM Card

Installing the Battery

To install the battery, insert the bottom of the battery into the opening on the back of the phone. Then push the battery down until the latch clicks and then install battery cover.

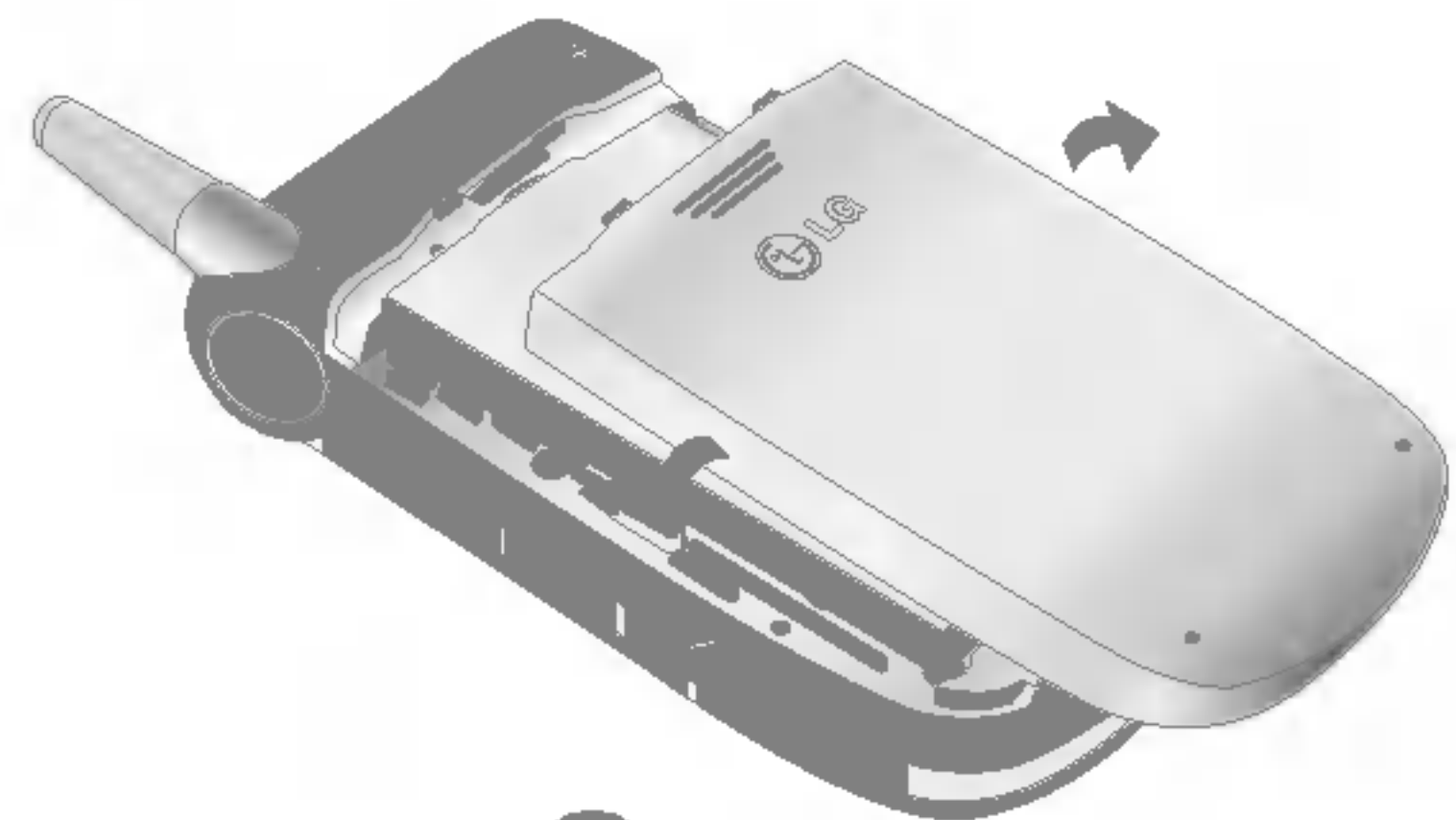
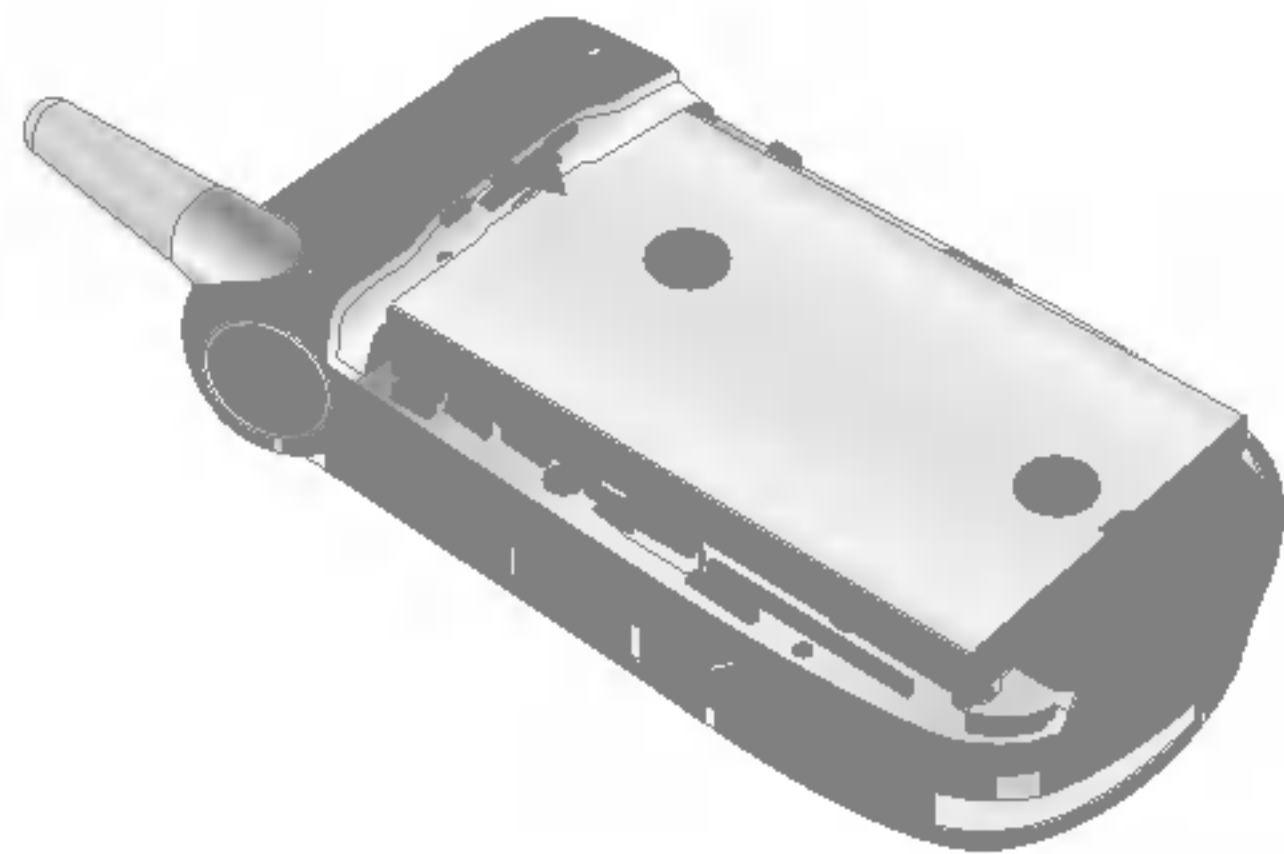

Getting Started

Removing the Battery

Turn the power off. (If power is left on, there is a chance you could lose the stored telephone numbers and messages.) Press the latches ① and open the battery cover ②. Then remove the battery.

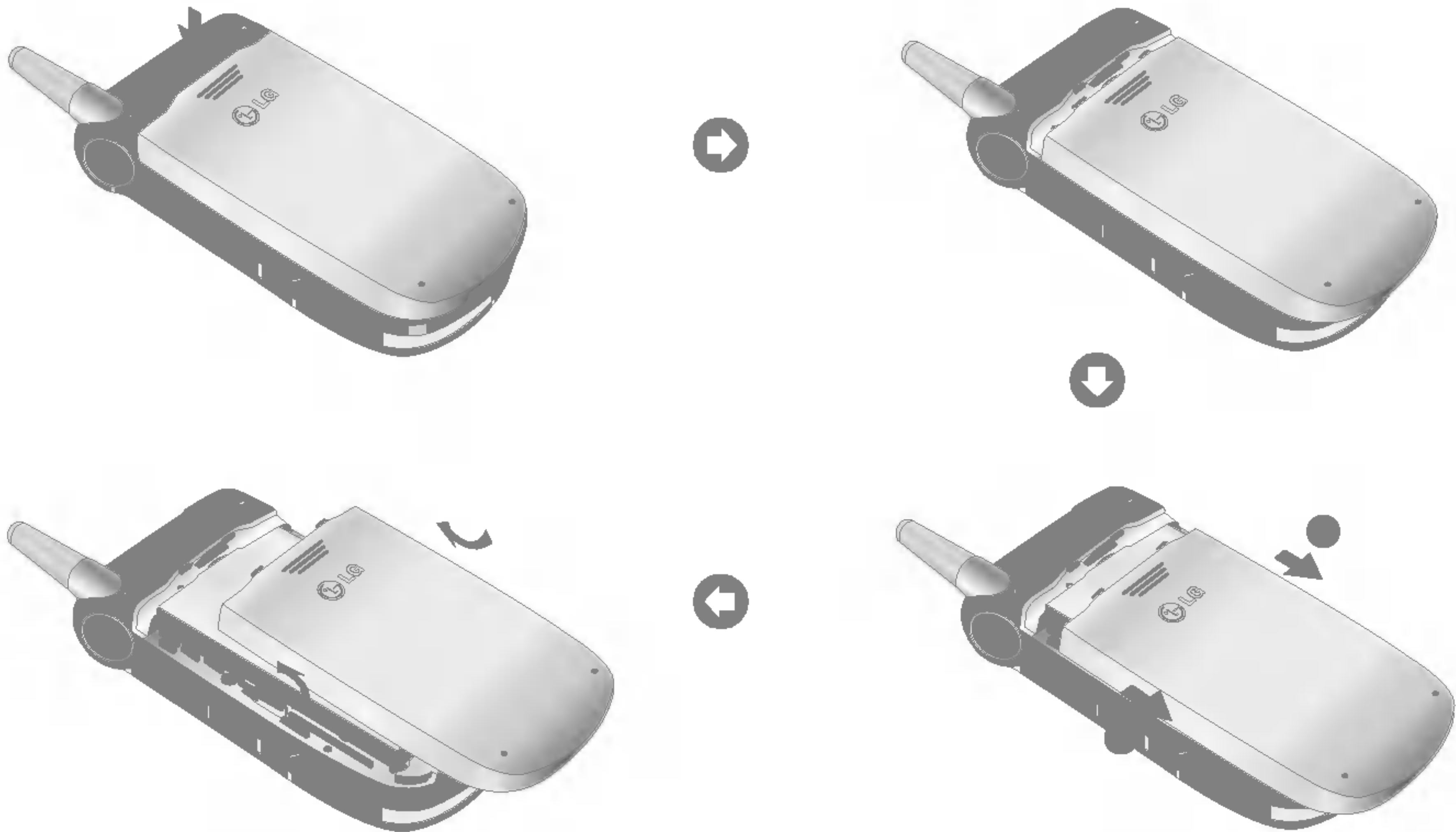

The battery is fully discharged and it will take sometime(under 30 minutes) to charge the battery to minimum operating level. When the red light is on, the handset can not be powered on. The red light will be turned off if the battery is charged to minimum operating level.

Warning

You can make video call with charger connected.

But if the battery capacity is under 10% the battery can be discharged when you use video call even though the charger is connected.

Charging the Battery

To use the charger provided with your phone:

1. With the battery in position on the phone, connect the lead from the charger to the bottom of the phone. Check that the arrow on the lead connector is facing towards the front of the phone.

2. Connect the charger to a standard AC wall outlet. Only use the charger that comes included with the package.

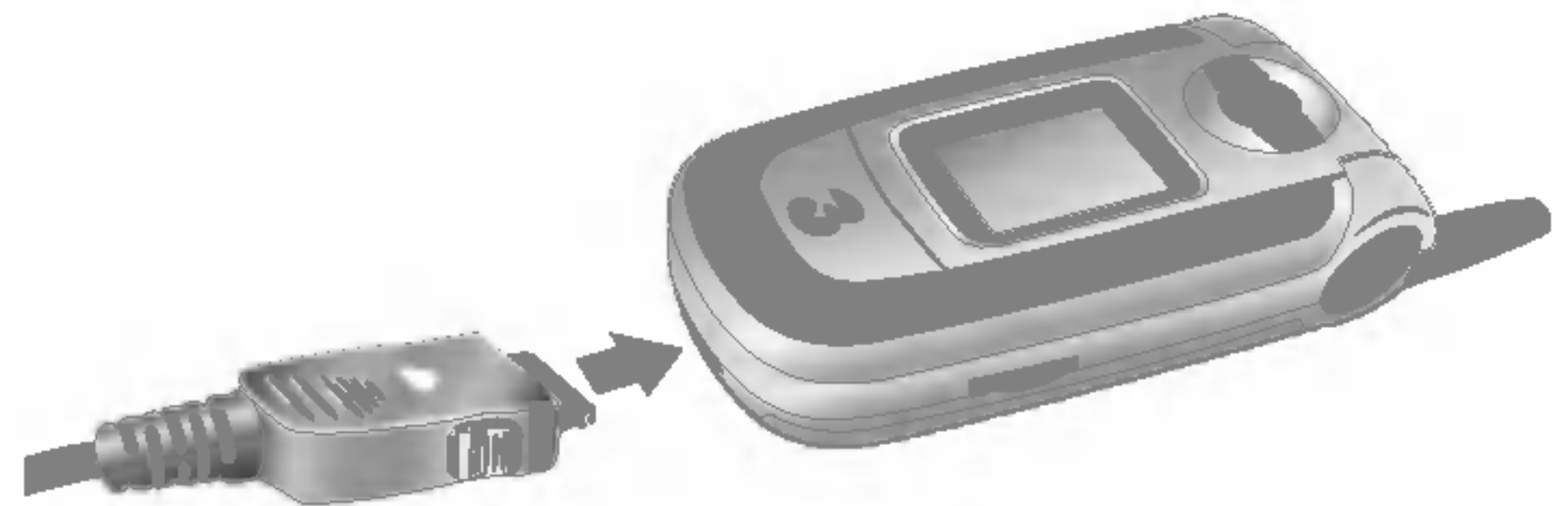

Warning

Do not force the connector as this may damage the phone and/or the charger.

Getting Started

Disconnecting the Charger

When charging is finished, disconnect the charger from the power outlet and from the phone by pressing on the gray tabs on both sides of the connector while pulling the connector out.



Notice

The battery delivered with your phone has to be fully charged before using it. Do not remove the battery or the USIM card while charging.

If your phone is being charged, the display will show the charging status.

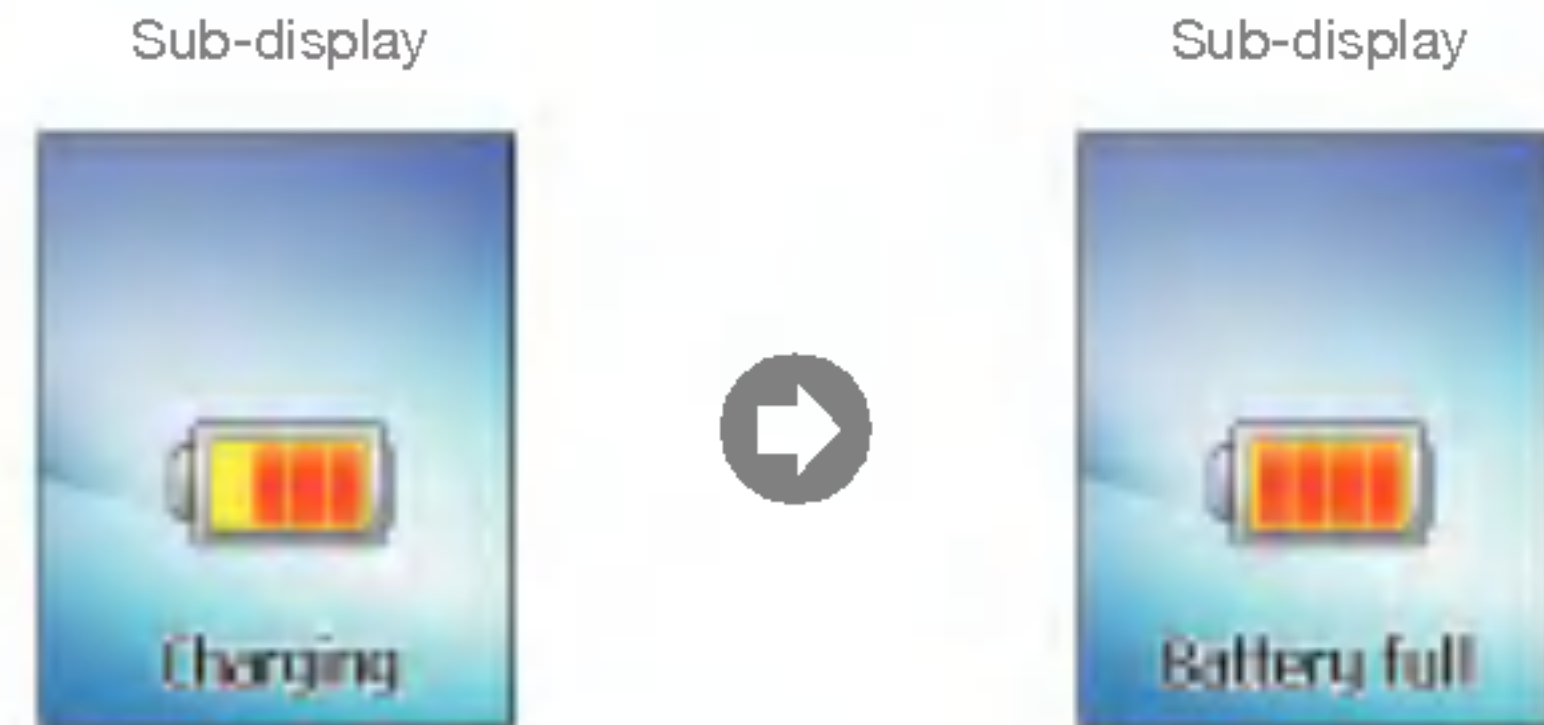

If the battery fails to charge completely:

After turning the phone on and off, please attempt to recharge the battery.

After detaching and reattaching the battery, please attempt to recharge the battery.

Battery Information and Care

1. Never use an unapproved battery since this could damage the phone and / or battery and could cause the battery to explode.
2. The battery does not need to be fully discharged before recharging.
3. Use only LG approved chargers specific to your phone model since they are designed to maximize battery life.
4. Do not disassemble or short-circuit the battery.
5. Keep the battery's metal contacts clean.
6. Replace the battery when it no longer provides acceptable performance. The battery can be recharged several hundred times before replacement.
7. Recharge the battery after long periods of non-use to maximize battery life.
8. Do not expose the battery charger to direct sunlight or use it in areas of high humidity such as a bathroom.
9. Battery life will decrease if exposed to extremely hot or cold temperatures.
10. Battery life will vary due to usage patterns and environmental conditions.
11. The use of extended backlighting, Browser, and data connectivity kits affect battery life and talk/standby time.

Getting Started

Installing the USIM card

Your USIM card contains your phone number, service details and contacts and must be inserted into your handset.

If your USIM card is removed then your handset becomes unusable until a valid one is inserted. Always disconnect the charger and other accessories from your handset before inserting and removing your USIM card.

Your USIM card may only be used in handsets which are enabled for 3 services. Any attempt to use the USIM card in other handsets may result in serious damage to the handset and may prevent you from being able to use it, including the making of emergency calls.

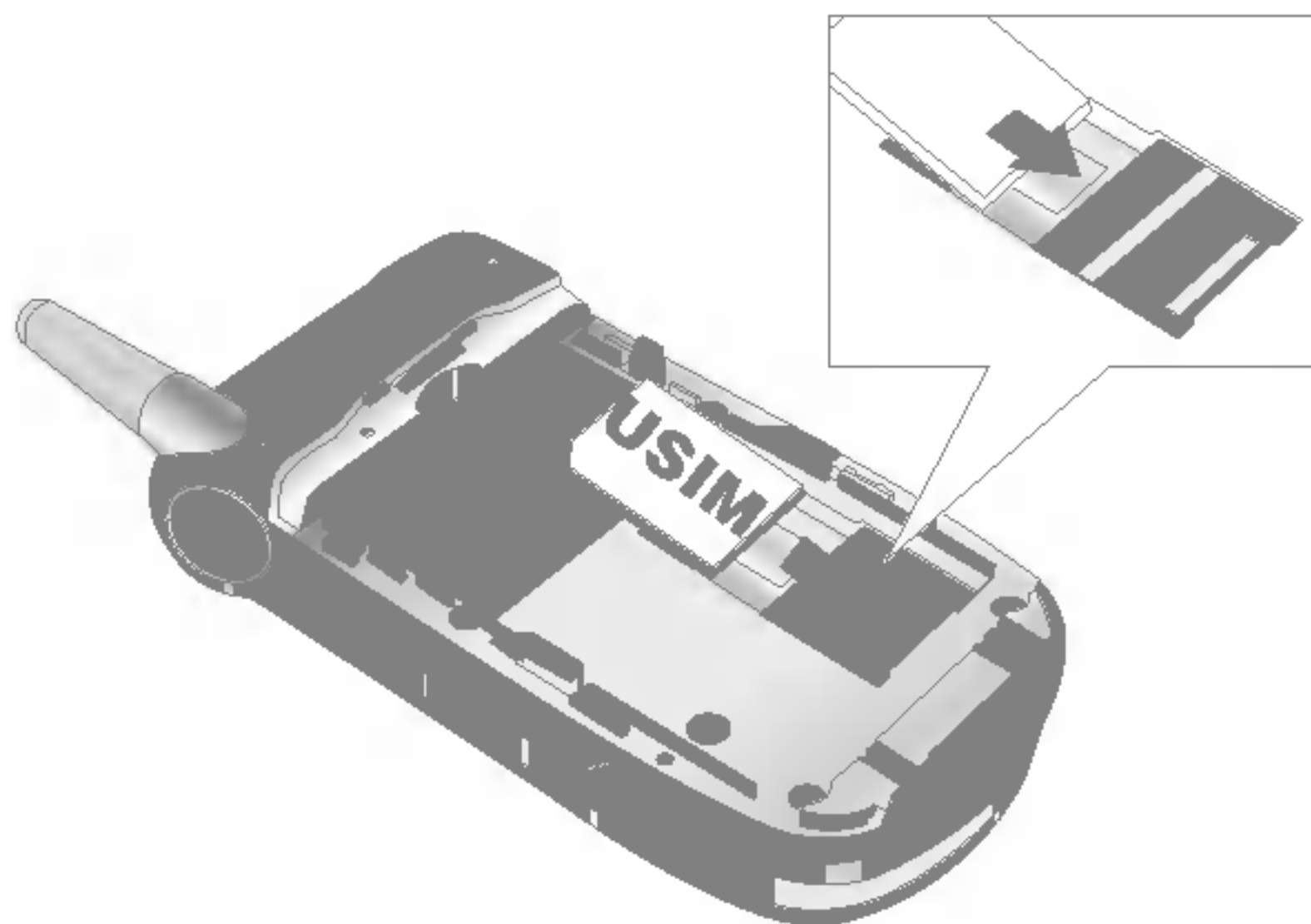

Notice

When you need to remove the USIM card, slide it towards the top of the phone and take it out of the holder.

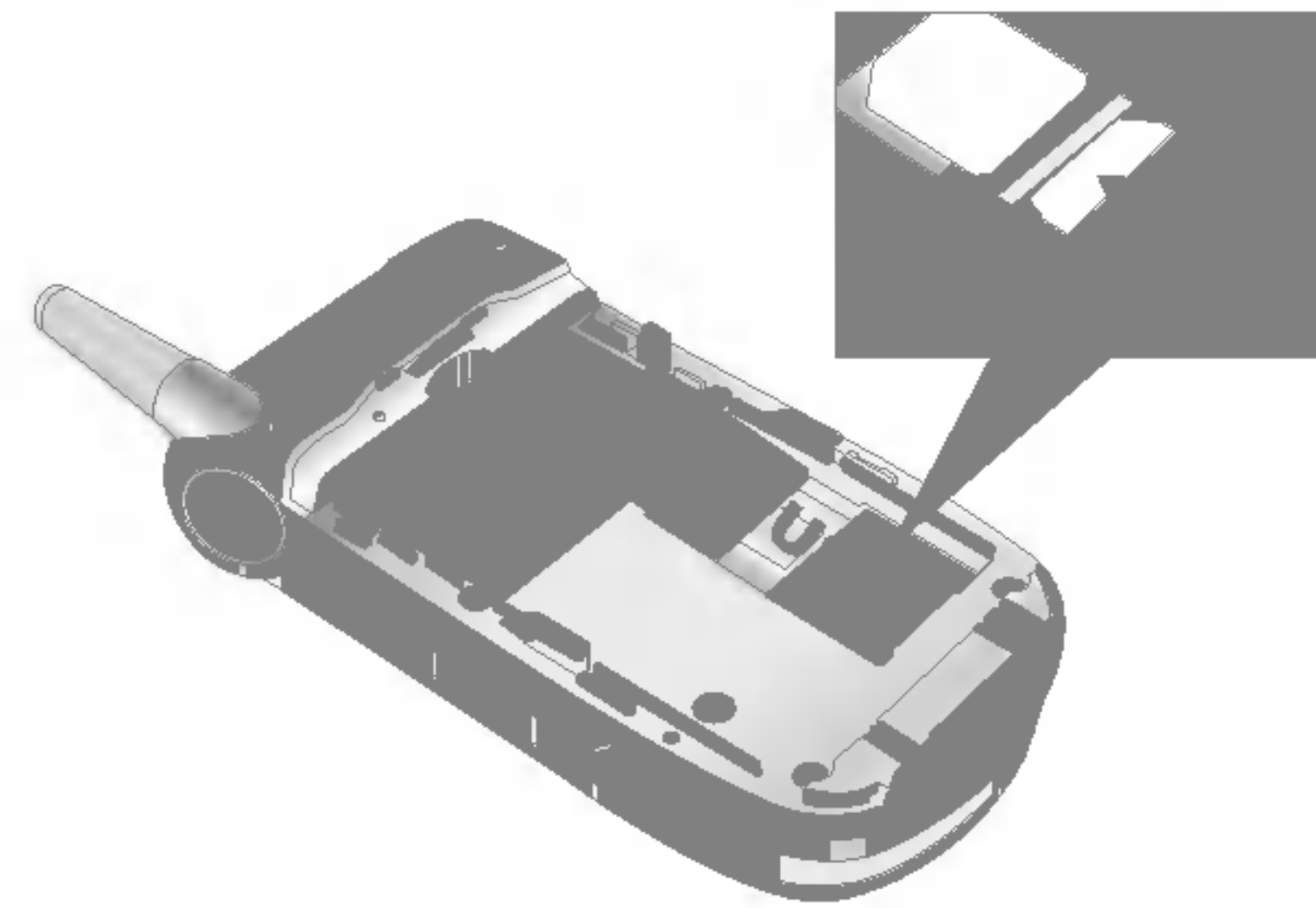

Notice

Before installing always make sure that the phone is switched off and remove the battery. The metal contact of the USIM card can be easily damaged by scratches. Pay special attention to the USIM card while handling and installing. Follow the instructions supplied with the USIM card.

Getting to know your LG U8380

Familiarise yourself with its features



Getting to know your LG U8380



Your handset's home screen

Your handset's home screen is divided into three basic displays: the icon indicator bar; a central window that includes the home screen; and the prompt bar. Each of these is described below:



The icon indicator bar

The icon indicator bar shows what operations are taking place and reminds you of battery and signal strength. This appears through all activities. The table below gives a brief explanation of the icons and their function.

The home screen

The central window of your start screen displays an image of your choice, when in use, this screen will display all of your functions and services.

The prompt bar





















The prompt bar displays in the soft boxes. These are activated by pressing the appropriate soft key under each one.

Getting to know your LG U8380

Display Information

The table below describes various display indicators or icons that appear on the phone's display screen.

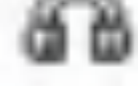
On-Screen Icons

	Battery level - indicates the amount of power in your battery. The greater the amount of solid colour the greater the power.		No-service area - indicates you are in the no-service area.
	Call diverting - indicates call divert option has been selected.		Roaming service - indicates that you are using a roaming service.
	Call reject - indicates call reject option has been selected.		ExpressLink message - indicates that there is new ExpressLink content.
	Voice message - indicates when you have a new voice message.		Indicates the Bluetooth connection is activated.
	Text - indicates when you have a new new text message.		Indicates when you have a new Bluetooth message.
	Multimedia - indicates when you have a new Multimedia message.		Alarm - indicates an Alarm.
	3G network - indicates whether you are in the 3 video service area.		Normal - indicates the General profile is activated
	When you leave the 3 video service area, your handset roams onto the voice & picture network or when abroad onto another network(2G/3G)		Silent - indicates the silent menu in Profile.
	2G network - indicates the strength of your handset's connection with a 2G network.		Vibrate only - indicates whether the vibrate function is on or off.
			Headset - indicates the headset menu in Profile.
			Outdoor - Indicates the loud profile is activated.

Your handset's keys and navigation



(1) The Triangle key

This key is your one-touch access to Today on 3, a world of communications, information and entertainment.

(2) The navigation key

Use for quick access to phone functions.

(3) The OK key

The button in the centre of the Navigation key allows you to select objects on the screen. Once you have scrolled to your desired choice use the OK key to select it. This function can be used in the majority of screens.

(4) The Menu key

This key takes you to the main menu from any screen.

(5) The Send key

This key is used to make and answer voice calls.

(6) The End key (On/Off)

This key is used to end calls and close down applications.

(7) The Clear key

This key has two functions. It will take you back to your previous screen and when in a text entry screen, it acts as a delete key.

(8) The soft keys

The left and right soft keys activate the prompts that appear in the soft boxes directly above them. These prompts change according to the screen content.

(9) The Video call key

To make and answer a video call.

(10) The Back key

This key takes you back to the previous screen.

Getting to know your LG U8380

Function of keys when phone is idle

Side of handset Keys



General Functions

Turning your handset on

Ensure that your USIM card is in your handset and the battery is charged.

Press and hold the  key until power is on.

Enter the USIM PIN code that was supplied with your USIM card if PIN code setting is on.

After a few seconds you will be registered on the network.

Turning your handset off

Press and hold the  key until power is off.

There may be some delay while the handset powers down.

Do not re-power the handset during this time.

Access Codes

You can use the access codes described in this section to avoid unauthorized use of your phone. The access codes (except PUK and PUK2 codes) can be changed by using the **Change codes** feature [Menu 3.5.3].

PIN code (4 to 8 digits)

The PIN (Personal Identification Number) code protects your USIM card against unauthorized use. The PIN code is usually supplied with the USIM card. When the PIN Code Request is set to Enable, your phone will request the PIN code every time it is switched on. When the PIN Code Request is set to Disable, your phone connects to the network directly without the PIN code.

PIN2 code (4 to 8 digits)

The PIN2 code, supplied with some USIM cards, is required to access functions such as Fixed Dial Number. These functions are only available if supported by your USIM card.

PUK code (4 to 8 digits)

The PUK (PIN Unblocking Key) code is required to unlock a blocked PIN code. Contact 3 Customer Services for the code.

PUK2 code (4 to 8 digits)

The PUK2 code, is required to unlock a blocked PIN2 code. Contact 3 Customer Services.

General Functions

Security code (4 to 8 digits)

The security code protects the unauthorized use of your phone. The default security code is set to '0000' and the security code is required to delete all phone entries and to restore the handset to factory setting.

Barring Password

The barring password is required when you use the call barring function. The password is obtained from the 3 Customer Services when you subscribe to this function.

Making and Answering calls

Ensure you tell the other party before recording a voice call.



Making and Answering a video call

You can make/answer a video call to a 3G video phone the other party must have a 3G video phone and be in a video service area.

To make/answer a video call, do the following.

1. Input the phone number using the keypad, or select the phone number from the calls made/received lists.

Note

To correct mistakes, press the  key briefly to delete the last number, or press and hold the  key to delete all numbers.

2. If you do not want to use the speakerphone, ensure you have the headset plugged in.

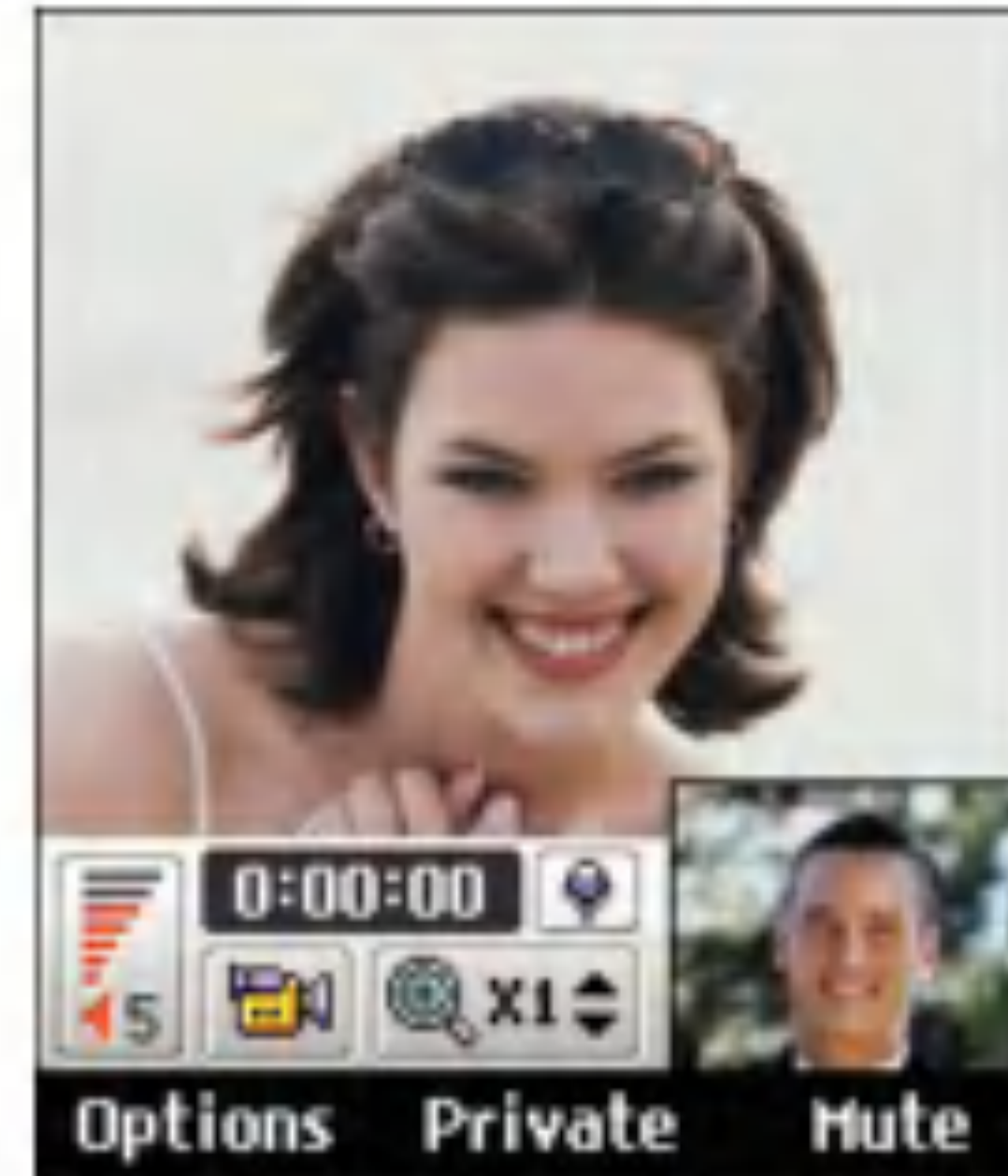





Note

The video call may take some time to connect. Please be patient. The connection time will also depend on how quickly the other party answers the call. While the video call is connecting, you will see your own images; after the other party has answered, their image will be displayed on screen.

3. Adjust the camera position if necessary.
4. Press the end key to finish the call, or close the handset.

General Functions

Making a voice/video call

1. Make sure your handset is powered on.
2. Enter the number including the full area code.
 - To delete a digit press the  key.
 - To delete all digits press and hold the  key.
3. Press the  key to make a voice call. Press the  key to make a video call.
4. Press the  key to finish the call, or close the handset.



Note

To activate the speakerphone during a Voice call, you have to press and hold the  key for at least 2 secs.

Making a voice/video call from Contacts



It is easy to call anyone whose number you have stored in your Contacts.

Press the down navigation key to access contact list.

Scroll to your chosen contact and press the  key. To make a voice call press the  key.

To make a video call press the  key. Press the  key to finish the call.

Making International Calls



1. Press and hold the  key for the international prefix. The '+' character can be replaced with the international access code.
2. Enter the country code, area code, and the phone number.
3. Press the  key.

Adjusting the Volume

During a call, if you want to adjust the earpiece volume, use the side keys of the handset. In idle mode with the flip cover open, you can adjust the key volume using the side keys.

Answering a Call

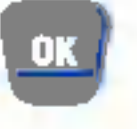
When you receive a call, the phone rings and the flashing phone icon appears on the screen. If the caller can be identified, the caller's phone number (or name if stored in your Contacts) is displayed.

1. Open the flip and press the  key to answer an incoming call.
If the **Press any key** menu option has been set to  key, **Press any key** will answer a call except for the  key.

Notice

- To reject an incoming call, press and hold down the side key on the left side twice of the handset without opening the flip (See page 137). If the flip is open, press the  key or the right soft key twice.

- If the **Open flip** menu option ((Menu #.9.4) is simply by opening) is on , you can answer the call simply by opening the flip.

2. End the call by closing the handset or pressing the  key.

Notice

You can answer a call while using the Contacts or other menu features.

Signal Strength

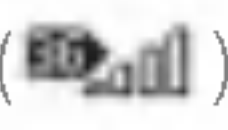
If you are inside a building, being near a window may give you better reception. You can see the strength of your signal by the signal indicator see the strength () on your handset's display screen.

Entering Text







You can enter alphanumeric characters using the keypad.

For example, storing names in the Contacts, writing a message, creating a personal greeting or scheduling events in the calendar all require entering text.

General Functions

Following text input methods are available in the handset.

Changing the Text Input Mode

1. When you are in a field that allows characters to be entered, you will notice the text input mode indicator in the upper right corner of the display.
2. Short pressing the  key cycles between , , ,  and .





Press 4, 3, 5, 5, 6, to type Hello



Press 0(space), 2, 6, 6, 6, 6
To type ann
Note
Please refer to the Using
the ABC Mode on page 49.

Using the T9 Mode

The T9 predictive text input mode allows you to enter words easily with a minimum number of key presses. As you press each key, the handset begins to display the characters that it thinks you are typing based on a built-in dictionary. As new letters are added, the word changes to reflect the most likely candidate from the dictionary.

1. When you are in the T9 predictive text input mode, start entering a word by pressing keys  to . Press one key per letter.
 - The word changes as letters are typed - ignore what's on the screen until the word is typed completely.
 - If the word is still incorrect after typing completely, press the  key once or more to cycle through the other word options.

Example

Press     to type Good

Press the  key to get Home



- If the desired word is missing from the word choices list, add it by using the ABC mode.

2. Enter the whole word before editing or deleting any keystrokes.
3. Complete each word with a space by pressing the  key.

To delete letters, press the  key.
Press and hold down the  key to erase entire words.

Using the ABC Mode

Use the  to  keys to enter your text.

1. Press the key labeled with the required letter:
 - Once for the first letter
 - Twice for the second letter
 - And so on
2. To insert a space, press the  key once.
To delete letters, press the  key. Press and hold down the  key to clear the display.

General Functions

Using the 123 (Number) Mode

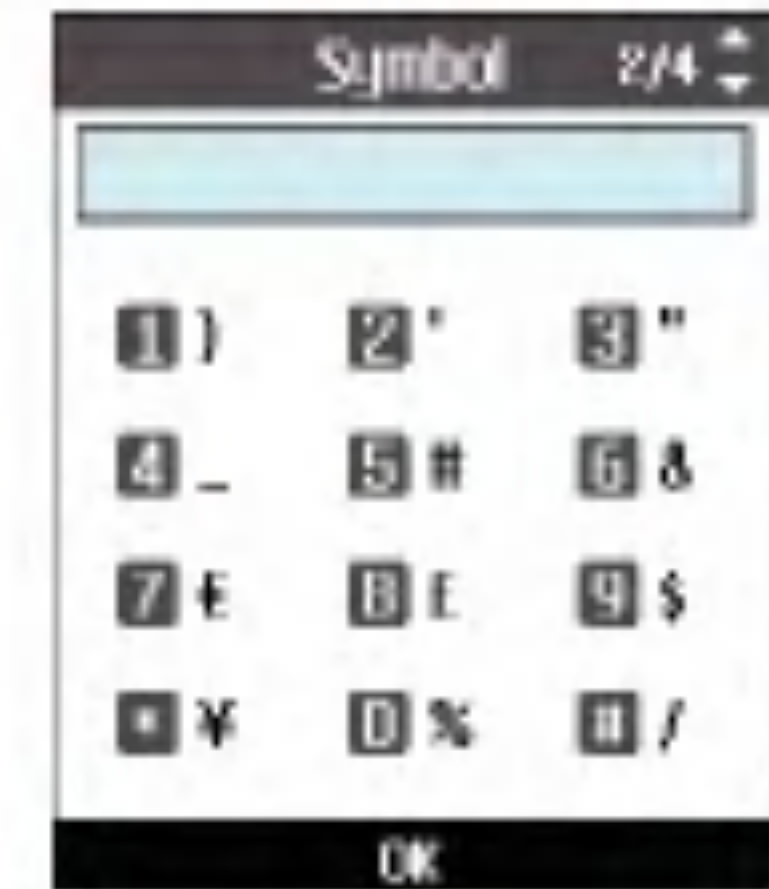
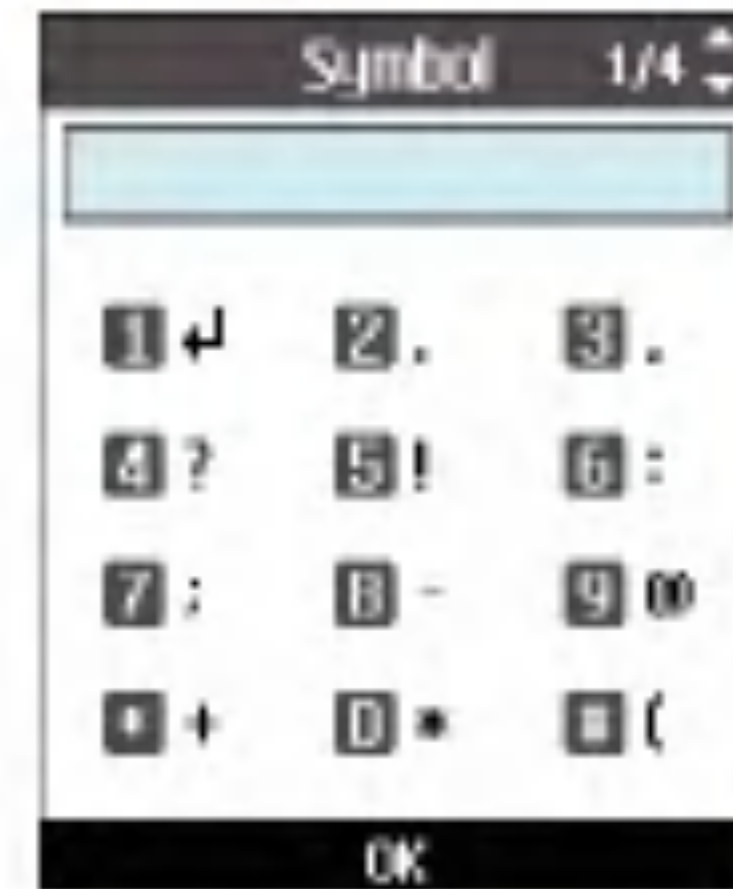

The 123 Mode enables you to enter numbers in a text message (a telephone number, for example).

Press the keys corresponding to the required digits before manually switching back to the appropriate text entry mode.



Using the Symbol Mode

The symbol mode enables you to enter various symbols or special characters.

To enter a symbol, press the right soft key [Symbol] or  key. Use the navigation and numeric keys to select the desired symbol and press the  key.



Character chart

General text entry rules for use with the abc mode.

Use the keypad to enter letters, numbers, symbols, and other characters with the abc mode. Press the same key repeatedly to cycle through available characters.



If you do not press a key for 2 seconds, the character in the block cursor is accepted, and the cursor moves to the next position.

Notice

Refer to the table below for more information on the characters available using the keys.

	@:/.	@:/.
1	.,?!“1-()@/:_	.,?!“1-()@/:_
2	abc2àáâãäåæç	ABC2ÀÁÂÃÄÅÆÇ
3	def3èéêë	DEF3ÈÉÊË
4	ghi4ìíîï	GHI4ÌÍÎÏ
5	jkl5Ĳ	JKL5Ĳ
6	mno6ñòóôõöøœ	MNO6ÑÒÓÔÕÖØŒ
7	pqrs7ß\$	PQRS7ß\$
8	tuv8ùúûü	TUV8ÙÚÛÜ
9	wxyz9	WXYZ9
0	space 0	space 0

Menu tree

Your handset offers a set of functions that allow you to use and customise the handset. These functions are arranged in menus and sub-menus, accessed via the two soft keys marked left soft key  and right soft key .

Each menu and sub-menu allows you to view and alter the settings of a particular function. The roles of the soft keys vary according to the applications and services; the label on the bottom line of the display just above each key indicates its current role.



Press the left soft key to access the available My stuff.

Press the right soft key to access the available Contacts.

Note

The left and right soft keys activate the prompts that appear in the soft boxes directly above them. These prompts change according to the screen content.

1. Screen (see page 58)

1.1 Screen theme

- 1.1.1 Home screen
- 1.1.2 Outgoing call
- 1.1.3 Sending message
- 1.1.4 Switch on
- 1.1.5 Switch off

1.2 Front screen theme

- 1.2.1 Home screen
- 1.2.2 Outgoing call

1.3 Menu style

- 1.3.1 Arc style
- 1.3.2 Grid style

1.4 Font

1.5 Backlight

1.6 Handset theme

- 1.6.1 Normal
- 1.6.2 Disco

1.7 Greeting message

- 1.7.1 On
- 1.7.2 Off

2. Profiles (see page 62)

2.1 Normal

2.2 Silent

2.3 Vibrate only

2.4 Headset

2.5 Outdoor

2.6 Customsied 1

2.7 Customsied 2

2.8 Customsied 3

3. Settings (see page 66)

3.1 Date & time

- 3.1.1 Time
- 3.1.2 Date
- 3.1.3 Auto update date/time
- 3.1.4 Daylight saving

3.2 Home screen softkeys

3.3 Network

- 3.3.1 Network seletion
- 3.3.2 Preferred list

3.4 Access points

- 3.4.1 Add new
- 3.4.2 View
- 3.4.3 Edit

3.5 Security

- 3.5.1 PIN code request
- 3.5.2 Handset lock
- 3.5.3 Change codes

3.6 Language

3.7 Memory status

3.8 Handset information

3.9 Reset settings

- 3.9.1 Clear memory
- 3.9.2 Default setting

Menu tree

4. Browser (see page 72)

4.1 Home

4.2 Bookmarks

4.3 Saved pages

4.4 Go to URL

4.4.1 Enter address

4.4.2 Recent pages

4.5 Security

4.5.1 Certificates

4.5.2 Session clear

4.6 Settings

4.6.1 Profiles

4.6.2 Character encoding

4.6.3 Scrolling control

4.6.4 Show Image

4.6.5 Cache

4.6.6 Cookies

4.6.7 Clear cache

4.6.8 Clear cookie

5. Messages (see page 80)

5.1 New message

5.1.1 Text message

5.1.2 Multimedia message

5.1.3 Email

5.2 Inbox

5.3 Mailbox

5.4 Drafts

5.5 Sent items

5.6 Templates

5.7 Settings

5.7.1 Text message

5.7.2 Multimedia message

5.7.3 Email

5.7.4 Videomail

5.7.5 Voicemail

5.7.6 ExpressLink

5.7.7 Info.Service

6. My stuff (see page 94)

6.1 Images

6.2 Videos

6.3 Sounds

6.4 Applications

6.5 External memory

7. Multimedia (see page 102)

7.1 Video camera

7.2 Camera

7.3 Voice recorder

7.4 Play lists

7.5 Settings

7.5.1 Video camera

7.5.2 Camera

7.5.3 Voice recorder

7.5.4 Memory status

8. Contacts (see page 106)

- 8.1 Add new
- 8.2 Search
- 8.3 Speed dials
- 8.4 Group
- 8.5 Service dial numbers
- 8.6 Own number
- 8.7 Settings
 - 8.7.1 Display data
 - 8.7.2 Show image/avatar
 - 8.7.3 Copy all
 - 8.7.4 Move all
 - 8.7.5 Clear contacts

***. Organiser (see page 114)**

- *.1 Calendar
- *.2 To do
- *.3 Memo
- *.4 Secret memo
- *.5 Date finder
- *.6 Dateulator
- *.7 Settings
 - *.7.1 Calendar
 - *.7.2 Memory info.
 - *.7.3 Clear all

0. Tools (see page 122)

- 0.1 Quick menu
- 0.2 Alarm clock
- 0.3 Connectivity
 - 0.3.1 Buletooth
 - 0.3.2 Server synchronisation
- 0.4 Calculator
- 0.5 World time
- 0.6 Unit converter

9. Applications (see page 110)

- 9.1 My applications
- 9.2 Download applications
- 9.3 Settings

Menu tree

#. Calling (see page 132)

#.1 Video calls

#.2 Call history

#.2.1 Missed calls

#.2.2 Received calls

#.2.3 Dialed calls

#.2.4 All calls

#.3 Call duration

#.4 Call costs

#.5 Call divert

#.5.1 Voice calls

#.5.2 Video calls

#.5.3 All fax calls

#.6 Call barring

#.6.1 Voice calls

#.6.2 Video calls

#.6.3 Deactivate all

#.7 Fixed dial numbers

#.7.1 On/Off:Off

#.8 Call waiting

#.8.1 Activate

#.8.2 Deactivate

#.8.3 View status

#.9 Settings

#.9.1 Call reject

#.9.2 Send my number

#.9.3 Auto redial

#.9.4 Answer mode

#.9.5 Minute minder



Screen

In this menu, you can configure screen display options including Screen settings and themes.

Screen theme

Home screen

You can select a wallpaper (animated or static) to display in idle mode.

Outgoing call

You can select an image to display when dialing a call.

The configuration is applied to both voice and video calls.

Sending message

You can select an image to display when sending a message.

Switch on

You can select an image to display when turning on the handset.



Switch Off

You can select an image to display when turning off the handset.

Front screen theme

You can configure the background of the front screen by themes.

Home screen

You can select a wallpaper to display in idle mode.

Outgoing call

You can select an image to display when dialing a call.

The configuration is applied to both voice and video calls.

Menu style

You can configure the menu style to **Grid style** or **Arc style**.

Font

You can configure the font size and colour of the numbers which appear in the home screen when you make a call.

Backlight

Use this to select whether or not the phone uses the backlight.

Main screen duration	Off 5 seconds 10 seconds 15 seconds 30 seconds 1 minute 2 minutes 3 minutes On
Front screen duration	Off 5 seconds 10 seconds 15 seconds 30 seconds 1 minute 2 minutes 3 minutes
Keypad duration	Off 5 seconds 10 seconds 15 seconds 20 seconds On

Screen

Handset theme

You can change the Wallpaper of the menu, soft key area, title bar area, and cursor by changing the menu theme.

Greeting message

Set a message that is displayed when the handset is turned on.





Profiles

You can configure Voice/Video ringtone, key tone, flip tone, sound effects, switch on, switch off, and volume. The ringtone type supports MP3, .3gp, AAC, MIDI, WAV and AMR. Supported profiles are Normal, Silent, Vibrate only, Headset, Outdoor, Customised 1, Customised 2 and Customised 3 profile. Select a desired profile, and press the **OK** key to activate the profile. When the cursor is moved to a profile, the corresponding menu appears on the soft bar. If you select View/Edit menu, you can view the settings of the profile, or can edit settings of the profile.

Profiles menu have the submenus as shown below.

■ Alert by

This option determines the incoming call and the message notification mode. You can select from Ring, Vibration, Silent, Ring & vibration Ring after vibration and Max ring & Vibration.

■ Voice ringtone

This option determines the Voice ringtone for incoming call notification.

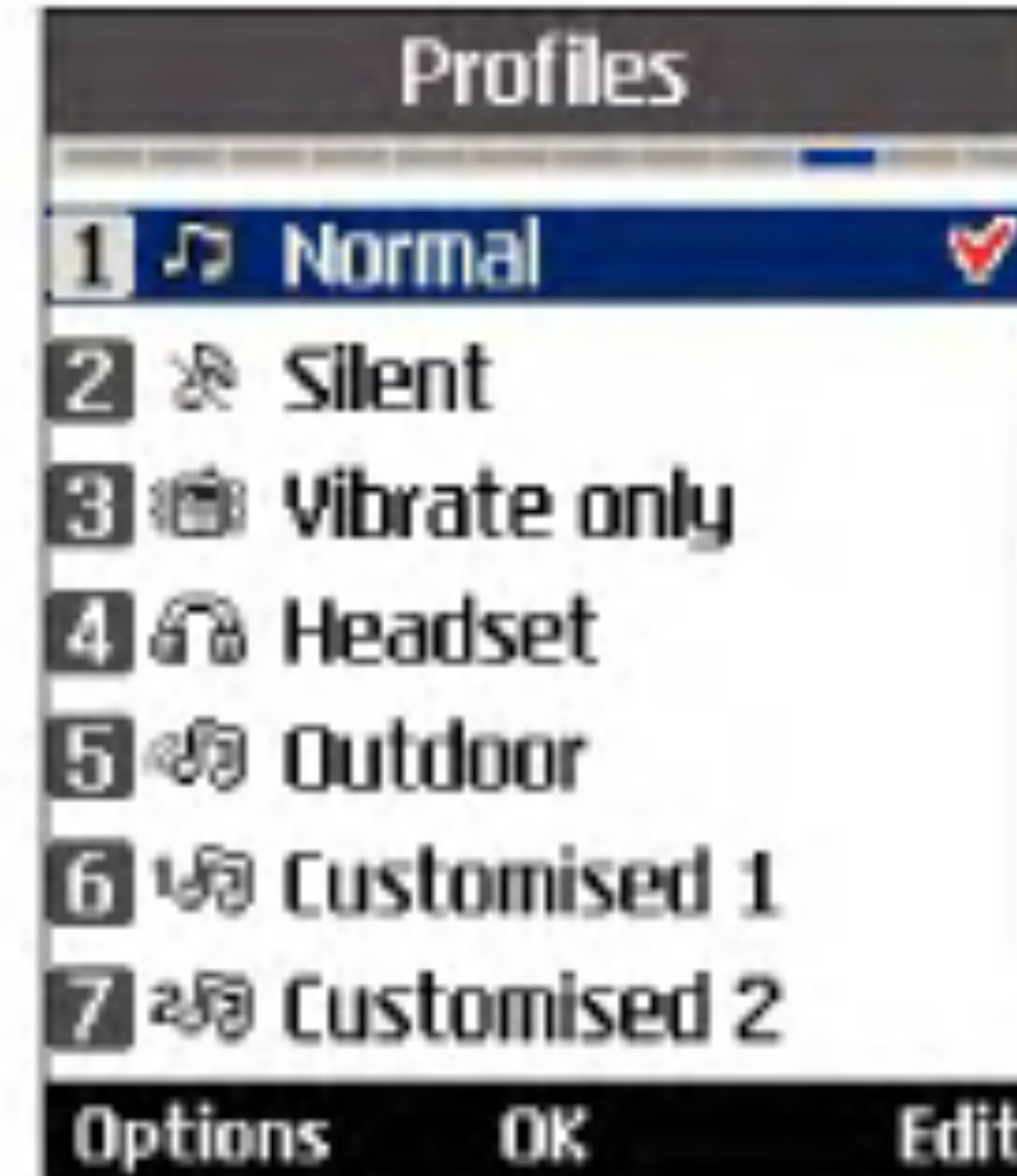

■ Video ringtone

This option determines the Video ringtone for incoming call notification.

■ Ring Volume

This option determines the ringtone volume for incoming call notification.

■ Message alert

This option determines the message alert that sounds when a message has arrived. You can select one of None, Once, Every 1 minute, Every 2 minutes, Every 5 minutes, and Every 10 minutes mode.

■ Message tone

This option determines the message tone that sounds when a new message has arrived.

■ Key tone

This option determines the key tone that is sounded when a key is pressed.

■ Key tone volume

This option determines the volume of the key tone.

■ Flip tone

This menu option allows you to select a melody that the phone sounds when it is flip open and closed.

■ Confirmation tone

This option determines if warning alerts are on or off.

■ Switch on sound

This option determines the switch on effect that is sounded when the handset is turned on.

■ Switch on file

This option allows you to select a melody that is sounded when the the phone is switched on.

■ Switch off sound

This option determines the switch off effect that is sounded when the handset is turned off.

■ Switch off file

This option allows you to select a melody that is sounded when the the phone is switched off.

Settings





Settings



Date & time

You can change the format of the time and date display as well as the actual time and date using the Time settings menu.

Time

1. Select the Time item from the handset settings list and then press the  key.
2. Input the current time using the numeric keys.
3. Select the time format using the left and right navigation keys.
4. Press the  key to save the time.

Date

1. Select the Date item from the handset settings list, and then press the  key.
2. Input the date using the numeric keys.
3. Select the date format using the left and right navigation keys.
4. Press the  key to save the date.



Note

Please make sure that you set the exact date and time to ensure that all 3 services operate correctly.

Auto update date/time

When Auto Update is configured to On, the time and date are automatically updated according to the current time zone. If Confirm first is selected, time and date update are confirmed before the automatic update.

Daylight saving

This function enables Summer time. Configuring Daylight saving to On immediately applies summer time (For example, if the current time is 04:53, summer time is then 05:53).

Home screen softkeys

The left and right soft keys activate the prompts that appear in the soft boxes directly above them. These prompts change according to the screen content.

Network

Network selection

■ Automatic

This function automatically searches for the network and registers the handset to the network.

■ Manual

This function enables you to search the network list and specify which network to attempt registration with.

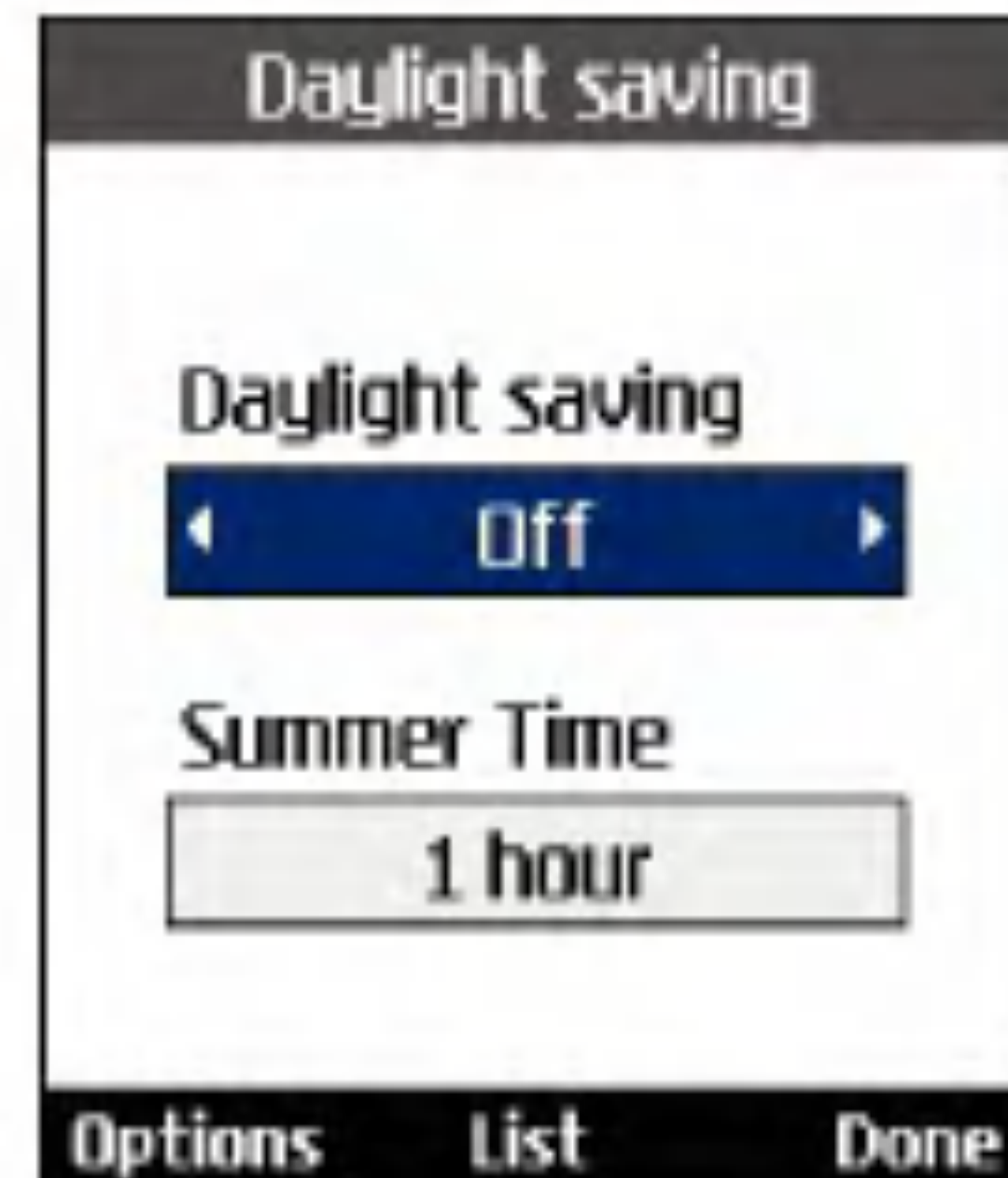

Preferred list

You can select preferred lists to display it saved in the current USIM card and can edit the current preferred list.

Access points

This menu shows the Access Point List. Select the  key [Edit]. Access Point has the following items.

- Connection title: Profile Name
- Bearer: UMTS/CSD/GPRS
- Username: User name

Settings

- Password: Password
- APN: APN information of the service provider

To modify these settings please call 3 Customer Service.



Security

You can set a PIN code. When it is activated, a window asking you to enter the PIN code appears when you turn on the handset so as to prevent unauthorized use of the handset.

PIN code request

You can activate a PIN (Personal Identification Numeric).

You can check the current status of configuration from the status bar.

1. Select PIN code request from the security menu and press the  key.
2. Configure this item to On or Off. If it is On, a PIN code will be required whenever the handset is turned on.
3. Input the current PIN code and press the  key.

4. Entering an incorrect PIN code 3 times in the PIN code input window invalidates the PIN code. In this case, the PUK code must be entered in order to reset the PIN code.
5. The maximum number of attempts at PUK code input permitted is 10. Entering an incorrect PUK code 10 times will restrict use of the handset. In this case, ask 3 Customer Service to unlock your handset.

Press the Back key in the PIN code input window to return to the previous step.

Handset lock

You can use security code to avoid unauthorized use of your handset.

When you switch on your handset, your handset will request security code always if you set phone lock to "Power on".

You can select the menu from **When switching on, If USIM changed, Lock now, and None.**

Change codes

You can change PIN, PIN2 and the security code.

Note

If you change the code and then forget it you will need to contact your place of purchase to unlock it or solve this problem.

■ PIN/PIN 2 code

This menu allows you to change the PIN or PIN2 code.

1. Select Change codes from the Security Settings List and press the **OK** key.
2. Select PIN or PIN2 Code and press the **OK** key.
3. Input the current PIN or PIN2 code, and then a new PIN or PIN2 code. Entering an incorrect PIN code 3 times invalidates the PIN code. In this case, you will need to enter the PUK or PUK2 code in order to reset the PIN code.
4. Entering an incorrect PUK code 10 times will restrict use of the handset. In this case, ask 3 Customer Service to unlock your phone.

■ Security code

This menu allows you to change the handset password. The maximum allowed numeric of

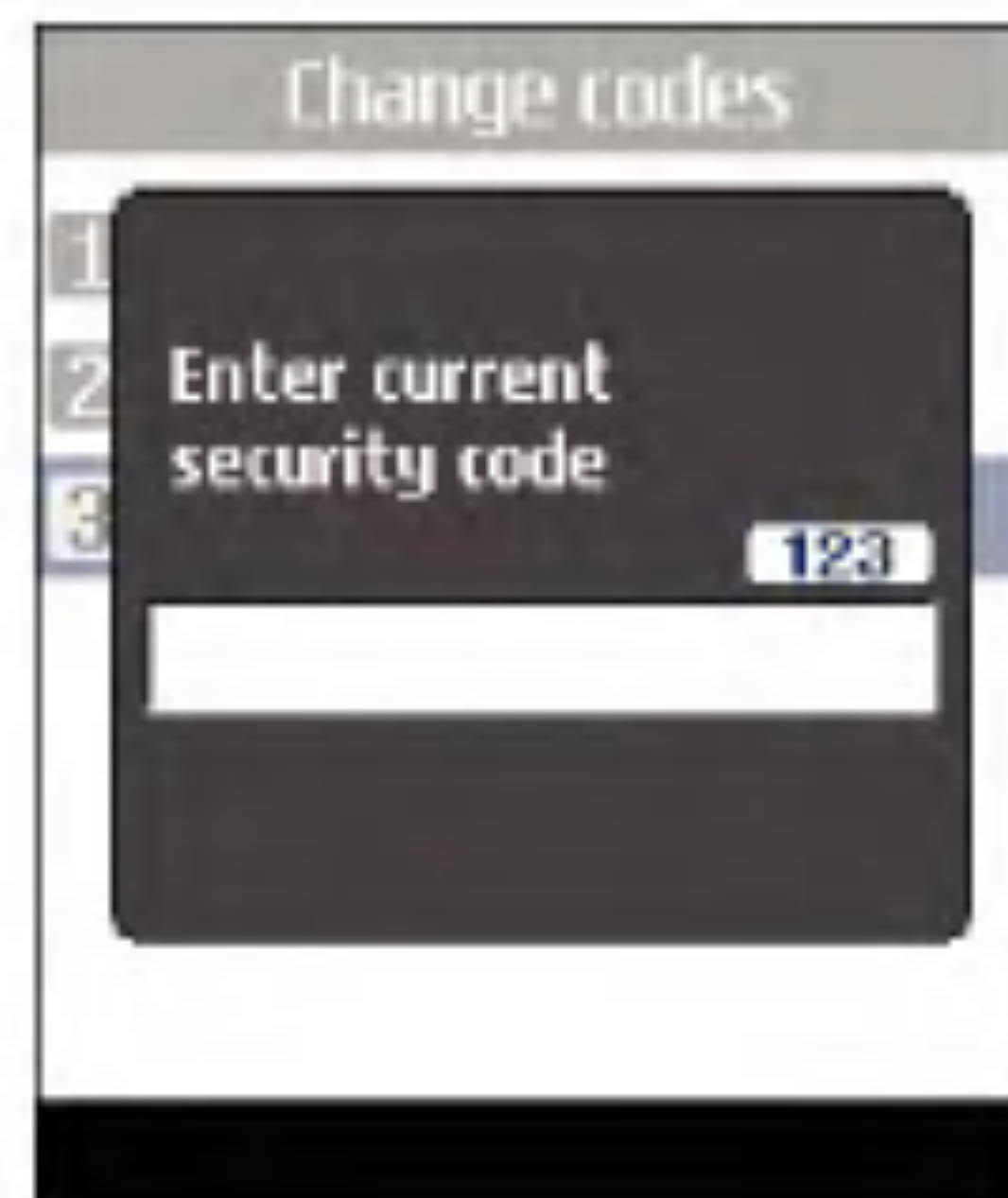

attempts of security code input is not limited like PIN and PIN2.

Language

This function allows you to set the language used in the handset.

Memory status

This menu is used to view the memory use of the phone and USIM card. You can obtain information about the amount of memory used by the contacts, the calendar, to do, memos, secret memos and text message and multimedia messages.

Settings

Common memory

This function shows the status of the user memory of the handset.

Reserved memory

This function shows the available memory for the user.

USIM memory

This function shows the status of the USIM card user memory.

External Memory

This function shows the status of the external card memory.

Handset information

This menu is used to view phone number, model number and software version information.

Reset settings

This function allows you to restore factory settings.

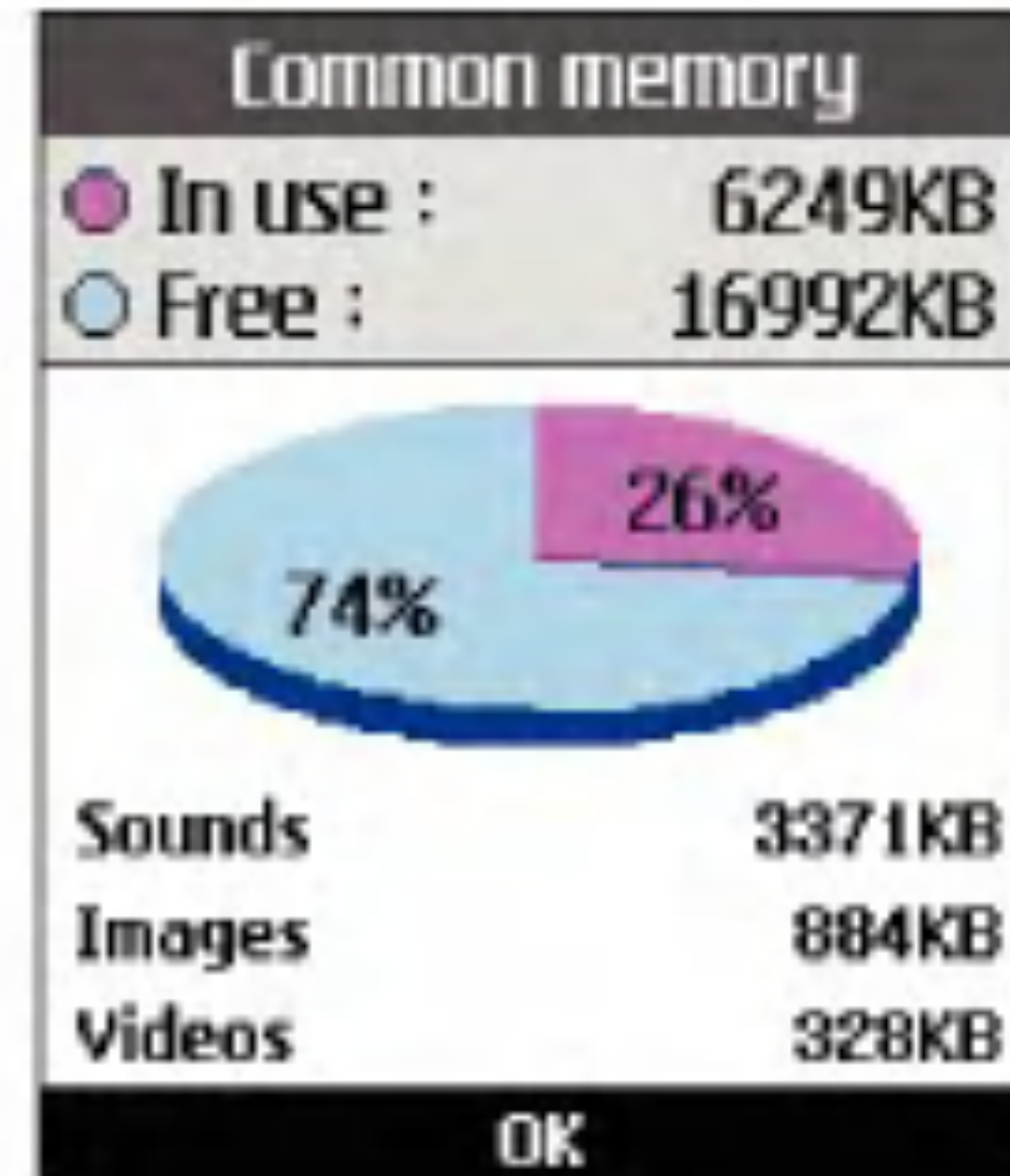

Undertaking a reset will not remove any user content.



Browser

3 brings you a whole world of communications, information and entertainment services.

You can ask for directions within major cities, get the latest news, keep up to date with Premier League action and much, much more.

The browser is available in the 3G coverage area.



To launch the browser in standby mode, press the  key.

Home



Select Home in the Internet Menu and then press the  key.

If you want to reload current page, press the right soft key [Reload].

The following options are available. Press the left soft key [Options].

-  Home: Moves to the initial homepage.
-  Reload: Loads the current page again.
-  Bookmark: You can add or save the current page to the Bookmark or view the list saved under Bookmark.



-  Settings: You can set the Browser related things such as Clear cache, Session info., Clear cookies, etc.
-  Back: Moves to the previous page.
-  Forward: Moves to the previous page.

The following example shows the functionality of browser menu 'Forward'.

1. Navigation Page A → Page B → Page C → Page D
2. On Page D, select a menu 'Back', it will place a user in Page C.

3. On Page C, if select a menu 'Back', move to Page B. Else if select a menu 'Forward', move to Page D again.

-  Go to URL: Connect to the specific URL after editing.

Bookmarks

This function allows you to store and edit frequently accessed sites.

The following options are available. Press the left soft key [Options].

Connect

Allows you to access the selected site.

Send as message

Selected bookmark URL can be sent via text message or multimedia message.

Add new

Adds a new site to the bookmarks list.

Edit

You can edit and save the name and address of the selected bookmark.



Mark/Unmark

Allows you to mark or unmark the selected site.

Delete

Delete the selected bookmark.

Saved pages

Saves the page on display as an off-line file. A maximum of 37 pages can be saved.

Go to URL

Connect to the specific URL after editing.

Browser

Security

■ Certificates

A list of the available certificates is shown.

■ Session clear

Allows you to close the security connection.

Settings

Profiles

Select the profiles by press  key to launch browser.

Character encoding

Select the character set one of the following list : Automatic, English(ASCII), English(ISO), English(LATIN), Unicode(UCS2 BE), Unicode(UCS2 LE), Unicode(UCS2 Auto), Unicode(UTF-16 BE), Unicode(UTF-16 LE), Unicode(UTF-16 Auto), Unicode(UTF-8).

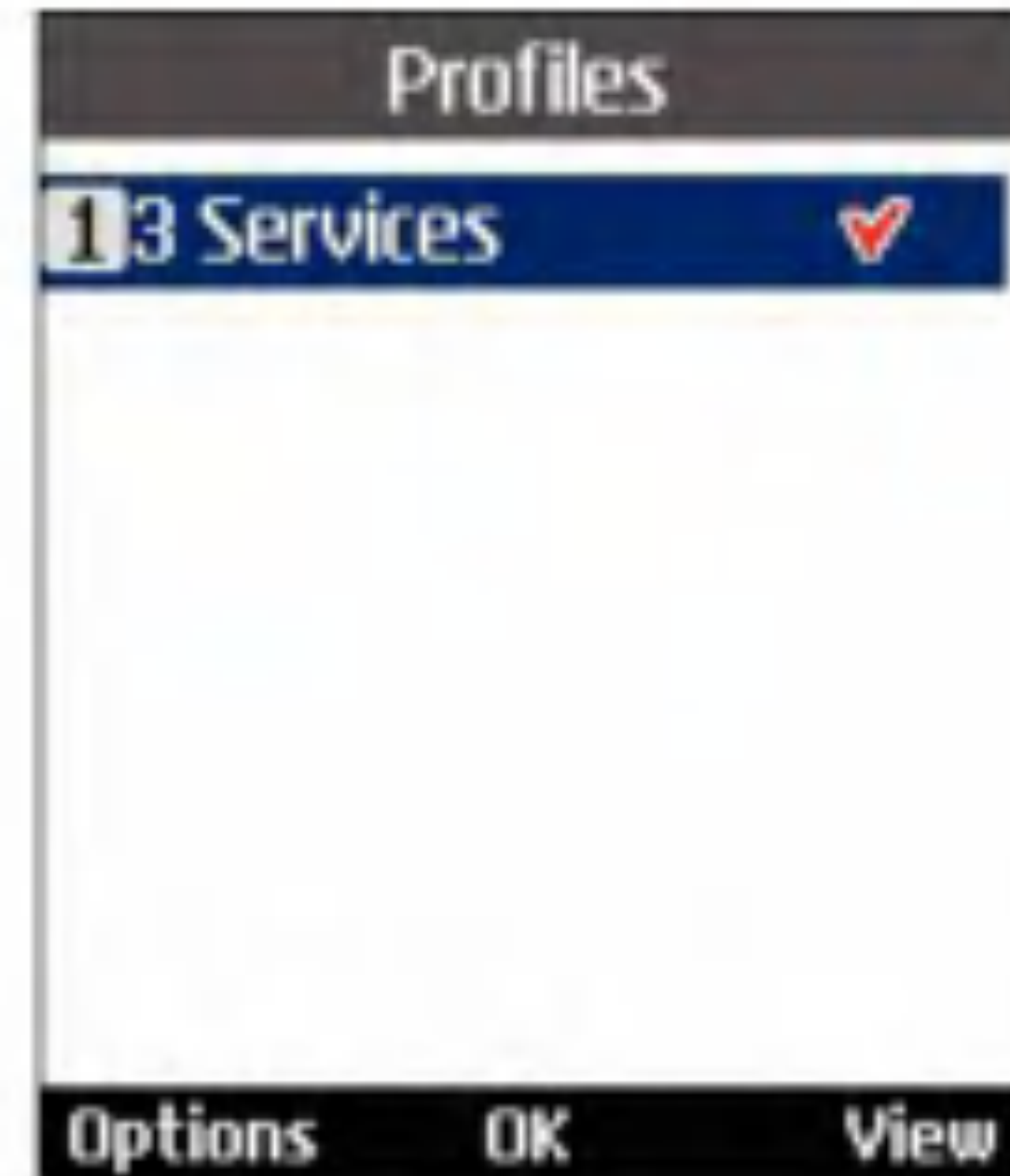

Scrolling control

Allows you to determine the scroll speed and select from **1 Line**, **2 Lines** and **3 Lines**.

Show Image

Choose if you want to view pictures when you are browsing.

Note

If you set to activate this function, the WAP page have images may be delayed until the transmission is completed. To fast transmission, the Show image should be deactivated.

Cache

Choose if you want to store the WAP (network) pages that you have accessed. If you set to activate this function, you can search the accessed WAP page quickly in cache memory.

Cookies

Choose if you want to store cookies received from the WAP site. If you set to deactivate this function, cookies never come in your phone.

Clear cache

Deletes the data saved in the cache memory.

Clear cookie

Deletes the data saved in the cookie memory.

Live Streaming

This application plays streaming in live. To have a pleasure time with this, you must launch browser first, access to entertainment services and find live streaming menu.

Press streaming icon to enjoy yourself a world of live streaming.



When you press streaming icon, the mobile terminal shows a live streaming automatically

VCR Control

If the streaming is in live, the mobile terminal shows VCR control skin with live bar.

1.  : Play and Pause alternately.
2. mute/unmute Key: mute/unmute the sound temporally.

Browser

OPTION

Press the left soft key [Options] to display the following popup menu items.

1. Mute/unmute : mute/unmute the sound temporally
2. Video Size: Normal/Landscape (for normal video) or Normal/Zoom/Landscape (for small size video)
3. Content Info
: Shows information about the current content provided by streaming server

Normal Streaming

Normal streaming is very similar to live streaming. To enjoy with this , you must launch browser, access to entertainment services and select the normal streaming menu like as news, stock, music, weather etc.

VCR Control

If the streaming is not in live, the mobile terminal shows VCR control skin with current play time



1.  : Play and Pause alternately.
2. Navigation left/right key: You can go forward/back with this key more rapidly. The following example shows the functionality of streaming menu “FF/REW”
 - press FF/REW Key during playing streaming, the mobile terminal paused video.
 - press more FF/REW Key , the mobile terminal display the new time and progress bar immediately. (user can select new time with FF/REW Key)
 - if there is no press Key more, then the mobile terminal start streaming with new time.



3. mute/unmute Key: mute/unmute the sound temporarily.

The **OPTION** is same as live streaming.







Messages

New message

Text message

Press the Message shortcut key to display Messages menu, select **New message** and then select **Text message**.

You can write and edit a single text message up to 160 characters. You can write and edit up to 10 concatenated messages.

1. Press the left soft key [Options]/ [Search contacts] or use the  key [Contacts] to specify the recipient from Contacts.
2. When you input content, a new window allowing you to input content appears. By using the left soft key [Options], you can input emoticons, templates, and phone numbers through the Contacts. By using the  key on the bottom, you can input various symbols.
3. When the message has been sent, it will be saved in the Sent items automatically. If the message has not been sent, it will be saved in the Draft automatically.





Multimedia message

Creating a Multimedia message

Select Messages from the top menu or pressing the Message shortcut key displays the message menu. In the menu, select Write message, and then select Multimedia message and create a Multimedia message.

You can simply send picture with a Multimedia message attaching the picture from your album or directly from the multimedia menu.

Multimedia message

1. You can create a Multimedia message.
2. Select **Multimedia message** from the **New message** menu and then press the  key.
3. You can edit a Multimedia message field using the Down navigation Key.
4. Move the highlight to the **To** field, and input the recipient of the message. You can specify the recipient by either phone number or Email address. You can search the Contacts by pressing the left soft key [Options] or the  key [Contacts].
When a recipient has been specified, another field where you can specify another recipient appears.
5. Move the highlight to the title field, and write a title. You can select and input a template or emoticon by pressing the left soft key [Options].
6. You can add, delete, or edit by each slide by moving the highlight to the text field.
7. You can save the message in the Drafts by using the left soft key [Options] while creating a message.
8. You can preview the message by using the left soft key [Options] while creating a message.
9. When you have completed creating a message, press the  key. You can send the message by selecting the right soft key [Send].
10. You can select the following functions using the left soft key [Options].
 - **Insert:** You can insert slide, image, video, audio, template, the name or phone number saved in the contacts.
 - **Send:** Sends the created Multimedia message at the time you wanted.
 - **Save as draft:** Saves the created Multimedia message to Drafts
 - **Preview:** Shows the created Multimedia message before sending it
 - **View attachment:** Views the attachment file list.
 - **Slide duration:** Changes the slide duration of each slide.
 - **Remove:** Removes attachment file or slide in the selected slide

Messages

- Goto: Move the slide you want to select.
- Dictionary: Selects dictionary mode.
- Add to dictionary: Adds the writing string in dictionary

Viewing Multimedia messages in the Preview and Drafts

1. You can preview a created Multimedia message.
2. If the message is too long to be displayed on screen, you can scroll the contents of the message by using the up and down navigation key.
3. Press the **OK** key to pause playback of the message, and press the **OK** key to resume playing the message.
4. If an audio or video file is attached to a Multimedia message, press the right soft key [Mute] to cancel the unmute function.

Viewing Multimedia messages in the Inbox and Sent items

1. Select a Multimedia message to view its contents.



2. If the message is too long to be displayed on a screen, you can scroll the contents of the message by using the up and down navigation key.
3. Press the **OK** key to pause playback of the message, and press the **OK** key to resume playing the message.
4. If an audio or video file is attached to a Multimedia message, press the right soft key [Mute] to activate the mute function. Press the right soft key [Mute] to cancel the unmute function.
When the multimedia message includes URL, you can try to connect the site. If the slide

includes URL, you can connect the URL by long press  key.

On the other hand, when you try to press up or down navigation key, the slide show is paused automatically, and the screen shows the menu "Link" on the right soft key if URL is included in the slide. You can connect the URL for browsing, downloading, and streaming.

5. Move to a desired message by using the left and right navigation keys.

6. Press the  key to reply the message.

7. You can select the following functions using the left soft key [Options].

- **Pause/Play:** Pauses/Plays the selected message.
- **Reply:** Creates reply to the selected message.
- **Forward:** Forwards the selected message.
- **Save address:** Saves the telephone numeric in the Contacts.
- **View attachment:** Shows the attachment file list.
- **New message:** You can create a new message.

- **Use:** Extracts the phone number, Email address or web address included in the text of the message.
- **Delete:** Deletes the selected message.
- **Go to header page:** Displays information about the selected message.

Email

To send the email, you should set up the email account. Refer to Email at page 90 first.

Message edit

1. Select **Email** from the Write Message menu.
2. You can input up to 20 addresses in the To, Cc fields and You can input up to 10 addresses in the Bcc field.

Tip

To input @, select the  key [Symbol], and then press 9 numeric key pad to input or press video call key.

3. Input the title of the mail to be sent in the Subject field.

Messages

4. Input the content of the mail to be sent in the Message field.
5. Specify up to 4 files to attach in the Attach field.
6. When you have finished writing a message, press the  key. You can send the message instantly.

Inbox

1. You can view saved messages. Select a message and then press the  key to view the message.
2. You can view the previous or next message by using the left and right navigation keys.
3. To view an Multimedia message, select **Retrieve** in the message view screen. Then the file is transmitted, and you can view the file when the message is received.
4. You can use the following functions by using the left soft key [Options].
 - **Reply:** Creates reply to the selected message.

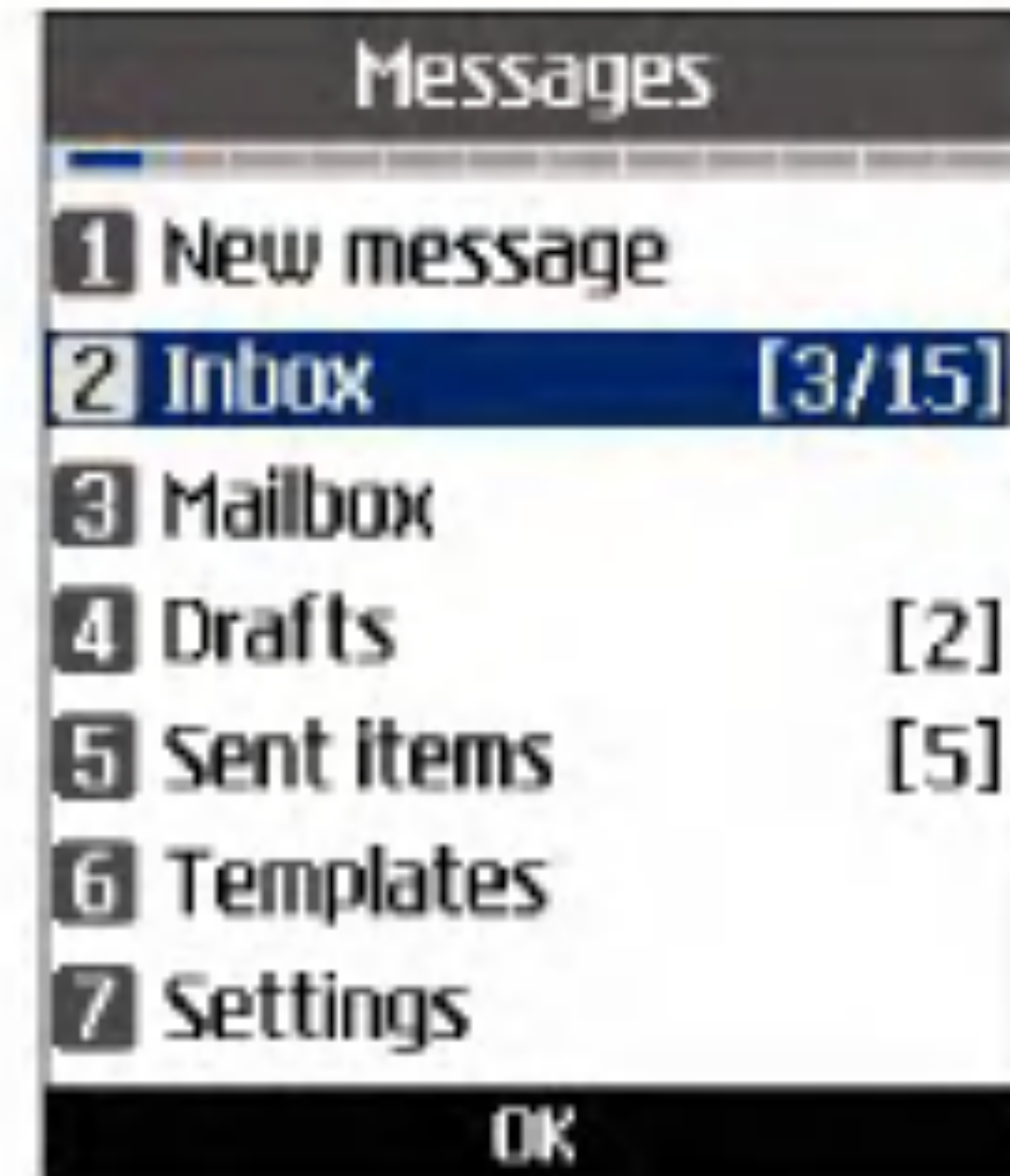

- **Forward:** You can forward a selected message.
- **View:** You can view a selected message.
- **New message:** You can write a new message.
- **Save address:** You can save the sender's address to the contacts.
- **Mark/Unmark:** You can mark or unmark the selected message.
- **Delete:** You can delete a selected message.
- **Copy:** You can copy a selected message.

■ **Move:** You can move a selected message.

■ **Message Info.:** Displays information about the selected message.

Viewing Bluetooth messages in the Inbox and the message popup window

1. You can view vCalendar, vCard, Image and play audio/video messages received by bluetooth.
2. You can view saved bluetooth messages. Select a bluetooth message and then press OK key in the inbox to view it.
3. You can view most recently recieved bluetooth message directly. Select Yes in the bluetooth message alert popup to view most recently recieved bluetooth message.
4. You can view the previous or next message of inbox by using the left and right navigation keys, if you are viewing bluetooth message via inbox.
5. You cannot view the previous or next message, if you are viewing most recent bluetooth message via bluetooth message alert popup.
6. You can use the Up and Down key to scoll

up and scroll down to view message content that are beyond visible area.

7. You can use View (center) key to view full screen image.
8. You can use Play (center) key to play audio /video file.
9. You can use the following functions by using the left soft key [Options].

■ **Copy to Calendar/Phonebook:** You can copy vCalendar/vCard message to your calendar/phonebook.

■ **Save Image, Audio and Video files:** You can save Images, audio and videos files to the phone for further use.

■ **New message:** You can write a new Text/ Multimedia/ Email message.

■ **Forward:** You can forward bluetooth vCalendar/vCard message via SMS/ Email.

■ **Delete:** You can delete bluetooth message that you are viewing currently.

Messages

Mailbox

1. Select Mailbox.
2. Select 3mail to retrieve messages from the Server List.
3. To retrieve new messages in the Mail Header screen, select Retrieve to retrieve the new Mail Header List.
4. Select your desired message from the retrieved mail headers to retrieve the mail contents from the server.

You can use the following functions by using the left soft key [Options].

- **Reply:** You can reply a selected message.
- **Forward:** You can forward the selected message.
- **Save address:** You can save the sender's address to the contacts.
- **New message:** You can write a new message via SMS, MMS and Email.
- **Use**
 - Number: Extracts the phone number included in the text of the message.



- Email address: View Email addresses up to 10 in the received message containing text. You can send a message or save as a contact by selected number.
- Web address: View URL up to 10 in the received message containing text. You can browser web or save as bookmark by selected number.
- **View attachment:** Shows the attachment file list.
- **Delete:** You can delete a selected message.
- **View to address:** Shows information in To/Cc/Bcc filed.

- **Message info.:** Displays information about the selected message.

Drafts

1. You can edit saved messages. Select a message and then press the **OK** key to edit the message.
2. You can use the following functions by using the left soft key [Options].
 - **Edit:** You can edit a selected message.
 - **Send:** You can send a selected message.
 - **New message:** You can write a new message.
 - **Mark/Unmark:** You can mark or unmark the selected message.
 - **Delete:** You can delete a selected message.
 - **Message info.:** Displays information about the selected message.

Sent items

1. You can view sent messages. Select a message and then press the **OK** key to view the message.
2. You can view the previous or next message by using the left and right navigation keys.
3. You can use the following functions by using the left soft key [Options].
 - **Forward:** You can forward a selected message.
 - **View:** You can view a selected message.
 - **Edit:** You can edit a selected message.
 - **New message:** You can write a new message.
 - **Save address:** You can save the sender's address to the contacts.
 - **Mark/Unmark:** You can mark or unmark the selected message.
 - **Delete:** You can delete a selected message.
 - **Message Info.:** Displays information about the selected message.

Messages

Templates

You can add, edit, and delete frequently-used useful phrases.

You can save frequently-used phrases in the input window in advance.

Settings

Text message

Delivery report

Allows you to activate or deactivate the report function. When this function is activated, the

network informs you whether or not your message has been delivered.

Validity period

Allows you to set the length of time for which your text messages will be stored at the Text message center while attempts are made to deliver them to the recipient.

Text message centre

The number of the Text message gateway is

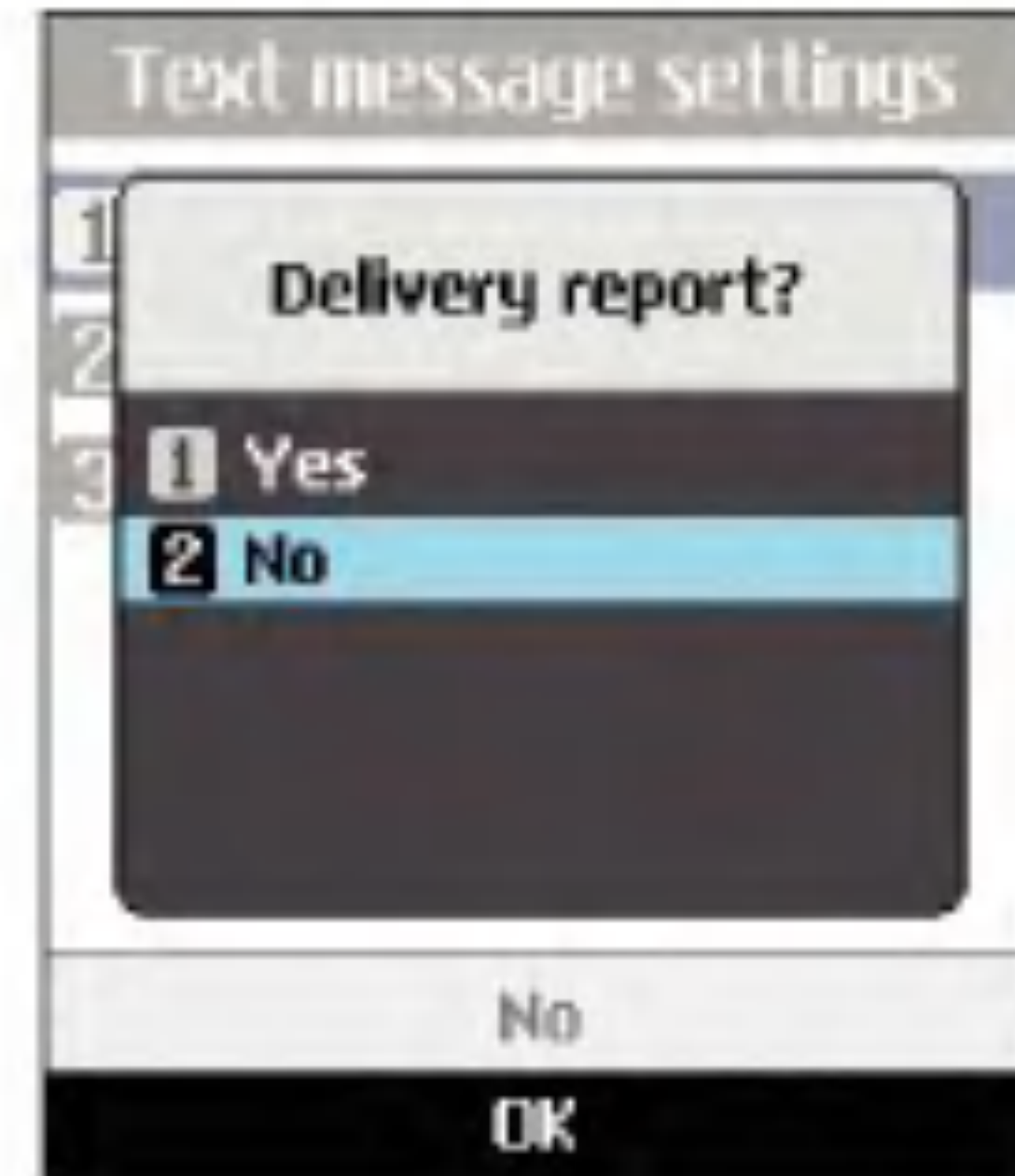

pre-loaded in your 3 handset and you should not change this. If you delete or change this by mistake contact 3 Customer Services for support.

Multimedia message

Select Multimedia message from the Settings menu to configure Multimedia message related options.

Delivery report

This menu allows you to determine whether to request a delivery confirmation mail to a recipient, and whether to allow sending delivery confirmation mail to a sender.

- Request report: Determines whether to request a delivery confirmation mail for a Multimedia message.
- Allow report: Determines whether to allow sending a delivery confirmation mail for a delivery confirmation mail request.

Read reply

This menu allows you to determine whether to request a read confirmation mail to a recipient, and whether to allow sending read confirmation mail to a sender.

- Request reply: Determines whether to request a read confirmation mail for a Multimedia message.
- Allow reply: Determines whether to allow sending a read confirmation mail for a read confirmation mail request.

Auto retrieve

This menu allows you to determine whether to automatically download a Multimedia message when a Multimedia message notification message arrives.

Validity period

This menu allows you to configure the term of validity for a message when transmitting a Multimedia message. The message would be saved in the Multimedia server only for the configured term.

Slide duration

This menu allows you to configure the duration of each page when writing the message.

Message size

This menu allows you to configure the maximum size of a Multimedia message when writing the message.

Multi. msg centre

The details for the Multimedia gateway are pre-loaded onto your handset and should not be changed. If you change or delete these by mistake contact 3 customer services for support.

You can add or edit the profile of multimedia message except the default profile.

Messages

Email

This menu allows you to edit, delete and add an Email account.

To set up an Email account, do the follows.

1. Select Messages/Settings/Email after pressing the  key in the idle screen.
2. Press the right soft key [Edit].
3. Enter details **Username** (your phone number with Country code without + eg 447782227302), **Password**, **Email address**, **Reply email address**, etc.
4. You can authenticate by pressing the right soft key [Done].

Once you have set up details of your other accounts, you can collect mail from those accounts by selecting Check for new mail from the Mail home page.

To retrieve an email, do the following:

1. Select the mail server you want to retrieve in the Mailbox.
2. Choose the email by using the navigation key.



3. Press the right soft key [Retrieve].
4. Press the  key.

Videomail

This menu allows you to get the video mail if this feature is supported by the network service provider. Please check with your network service provider for details of their service in order to configure the handset accordingly.



Voicemail

This menu allows you to get the voice mail if this feature is supported by the network service provider. Please check with your network service provider for details of their service in order to configure the handset accordingly.

ExpressLink

You can order ExpressLink from WAP service providers. ExpressLink is notifications of, for example, news headlines and it may contain a text message or address of a WAP service. For availability and subscription, contact your WAP service provider.

Info.Service

Info service messages are text messages sent by the network to GSM phone users. They provide general information such as weather reports, traffic news, taxis, pharmacies, and stock prices. Each type of information is associated with a number, which can be obtained from the service provider. When you receive an info service message, a popup message will indicate a new message receipt or

the info service message will be displayed directly.



My stuff

Images

This application enables you to view still images. The image files saved in the handset are represented by thumbnails. Select the desired image to view the enlarged image.

Notice

Features within the Edit Image might not work due to large image size or lack of internal phone resource. For example, Rotate will not work for images greater than 640x480.

Press the left soft key [Options] to display the following popup menu items (in 1. Image list).

- View: Moves to the camera application for taking still image photographs.
- Create new folder: You can create new folder.
- Send as message: Enables the selected image to be sent via MMS, Email and Bluetooth.
- Files
 - Move: Enables the file to be moved other folder.

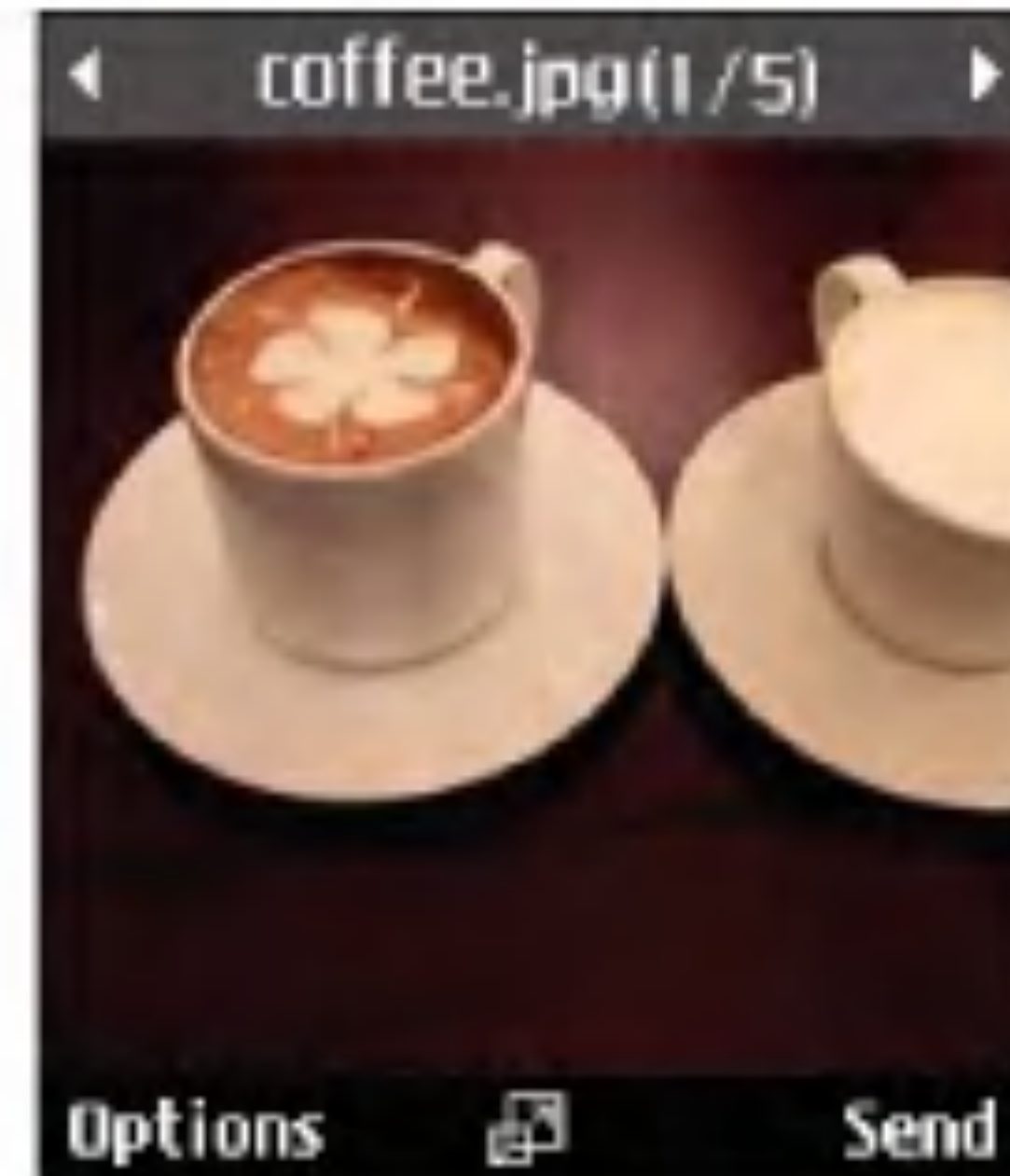

- Copy: Enables the file to be copied other folder.
- Rename: Enables the image to be renamed.
- Edit: Enables the image to be edited.
- Info: Shows information about the selected image file.
- Delete: Deletes the selected image.
- Mark/Unmark: You can mark or unmark the selected file.
- Main screen theme: You can set an image as the screen theme (Home screen, Outgoing call, Sending message, Switch on, Switch off).

- Front screen theme: You can set an image as the screen theme (Home screen, Outgoing call)
- Slide show: You can start the slide show.
- Sort by: Sorts images.
- List/ Grid view: You can set the view style.
- Memory status: Shows the current memory usage.

Press the left soft key [Options] to display the following popup menu items (in 2. Picture Viewer).

- Go to list: moves to the application list.
- Send as message: Enables the selected image to be attached to a message and the message sent.
- Files
 - Edit picture: You can edit the image.
 - File info.: Shows information about the selected image file.
- Delete: Deletes the selected image.
- Zoom: You can zoom in and out the image.

- Main screen theme: You can set an image as the screen theme (Home screen, Outgoing call, Sending message, Switch on and Switch off).
- Front screen theme: You can set an image as the screen theme (Home screen, Outgoing call)
- Slide show: You can start the slide show.

Videos

This application plays recorded video (.3gp or MPEG4 files). Select a desired video.

The following options are provided by the Video Player.

There are two scenarios;

- 1) Mute/Unmute status and
- 2) Pause status

Press the left soft key [Options] to display the following popup menu items (when 1. Unmute/Mute status).

- Send as message: Enables the selected video to be sent via MMS, Email and Bluetooth.

My stuff

- Delete: Deletes the selected video file.
- File info.: Shows information about the selected video file.
- Sound theme: You can set an audio file as the sound theme (Voice ringtone, Video ringtone).
- Video Size: Enables the selected video to be shown as Normal and Landscape. In Play mode, you can change the video size to press  key.
- Mute/Unmute: Mutes/Unmutes the sound temporarily.
- Previous file: Plays the previous video file.
- Next file: Plays the next video file

Press the left soft key [Options] to display the following popup menu items (when 2. Pause status).

- Send as message: Enables the selected video to be sent via MMS, Email and Bluetooth.
- Delete: Deletes the selected video file.

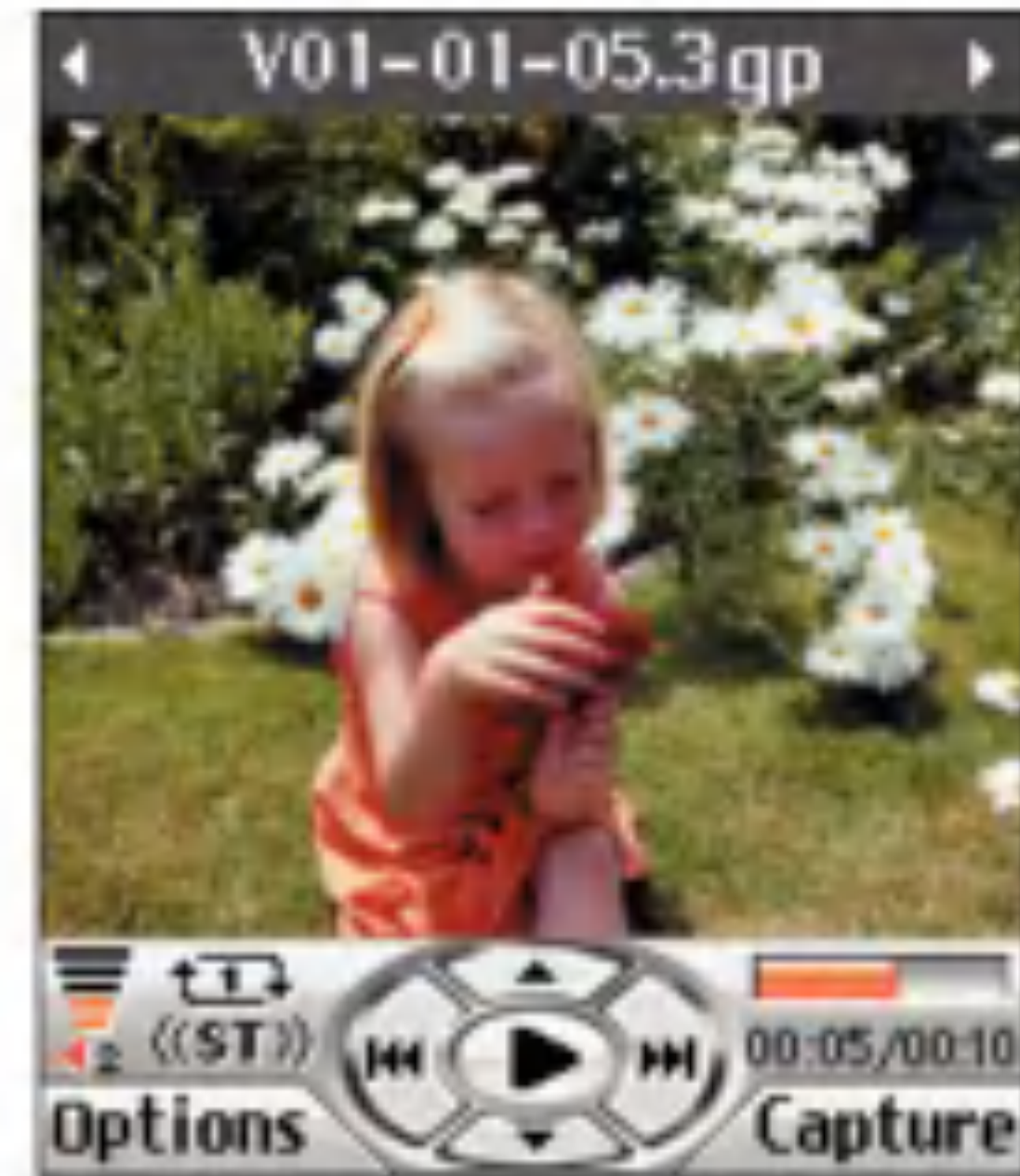

- File info.: Shows information about the selected video file.
- Sound theme: You can set an audio file as the sound theme (Voice ringtone, Video ringtone).
- Video Size: Enables the selected video to be shown as Normal and Landscape. In Play mode, you can change the video size to press  key.
- Capture: Captures an image from the video file.
- Previous file: Plays the previous video file.
- Next file: Plays the next video file.



Press the left soft key [Options] to display the following popup menu items

- Play: Moves to the camera application for taking still image photographs.
 - Create new folder: You can create new folder.
 - Send as message: You can attach the selected video file to a message and send the message if not content protected.
 - Files
 - Move: Enables the file to be moved other folder.
 - Copy: Enables the file to be copied other folder.
 - Rename: Enables the video to be renamed.
 - Info: Shows information about the selected video file.
 - Delete: Deletes the selected video file.
 - Mark/Unmark: You can mark or unmark the selected file.
 - Sound theme: You can set an audio file as the sound theme (Voice ringtone, Video ringtone).
 - Sort by: Sorts video files.
 - List/ Grid view: You can set the view style.
 - Memory status: Shows the current memory usage.
-

My stuff

Sounds



This application plays MP3, MIDI and AAC files so that you can listen to them. Select your desired audio file in the list mode showing audio files. The following options are provided by the My sounds in the Audio Player.

There are two scenarios: 1) Unmute status and
2) Mute status.

Press the left soft key [Options] to display the following popup menu items (when 1. Unmute status).

- Send as message: Enables the selected audio file to be sent via MMS, Email and Bluetooth
- Delete: Deletes the selected video file.
- File info.: Shows information about the selected audio file.
- Sound theme: You can set an audio file as the sound theme (Voice ringtone, Video ringtone, Message tone, Switch on and Switch off).
- Mute: Mutes the sound temporarily.





- Set repeat: Repeats the audio file.
- Play in background: If the function is activated it is still possible to listen to background music without a headset even though the flip is closed. The music can also be heard when switching menus using the  key in the state of flip open, but not using the  key nor the  key.

The Call and alarm having higher priority than a background music will make it paused and resumed, but such a message tone, flip tone, key tone, and confirmation tone never happen during background music.

- Equalizer: You can set the equalizer.
- Previous file: Plays the previous audio file.
- Next file: Plays the next audio file.

Press the left soft key [Options] to display the following popup menu items (when 2. Mute status).

- Send as message: Enables the selected audio file to be sent via MMS, Email and Bluetooth
- Delete: Deletes the selected video file.
- File info.: Shows information about the selected audio file.
- Sound theme: You can set an audio file as the sound theme (Voice ringtone, Video ringtone, Message tone, Switch on and Switch off).
- Unmute: Unmutes the sound temporarily.
- Set repeat: Repeats the audio file.
- Play in background: If the function is activated it is still possible to listen to background music without a headset even though the flip is closed. The music can also be heard when switching menus using the

 key in the state of flip open, but not using the  key nor the  key.



The Call and alarm having higher priority than a background music will make it paused and resumed, but such a message tone, flip tone, key tone, and confirmation tone never happen during background music.

- Equalizer: You can set the equalizer.
- Previous file: Plays the previous audio file.
- Next file: Plays the next audio file.

Press the left soft key [Options] to display the following popup menu items

- Play: Plays the selected audio file.
- Create new folder: You can create new folder.
- Send as message: Enables the selected image to be sent via MMS, Email and Bluetooth.
- Files
 - Move: Enables the file to be moved other folder.

My stuff

- Copy: Enables the file to be copied other folder.
- Rename: Enables the image to be renamed.
- Info: Shows information about the selected audio file.
- Delete: Deletes the selected image.
- Mark/Unmark: You can mark or unmark the selected file.
- Sound theme: You can set an audio file as the sound theme (Voice ringtone, Video ringtone, Switch on, Message tone, Switch off).
- Play in background: If the function is activated it is still possible to listen to background music without a headset even though the flip is closed. The music can also be heard when switching menus using the  key in the state of flip open, but not using the  key nor the  key.

The Call and alarm having higher priority than a background music will make it paused and resumed, but such a message tone, flip tone, key tone, and confirmation tone never happen during background music.

- Sort by: Sorts audio files.
- Memory status: Shows the current memory usage.

Applications

For further details. see the page 110, (Menu 9 Applications)

External memory

If your phone is installed the multimedia memory card in the card slot, you can save images, sounds, and videos on the memory card. You can check the current status of the external memory in Memory status menu.

7.Multimedia



Multimedia

Video camera

This application enables you to record a video clip. You can play and watch a saved video file while using this function. Once recorded, a video clip can be sent by Multimedia message or Email.

Press the left soft key [Options] to display the following popup menu items.

- Quality: Determines the quality of a video clip.
- Light: Determines the light operation.
- Zoom: Determines the zoom rate.
- Brightness: Determines the brightness.
- WB: Determines the white balance.
- Night mode: Determines the night mode.
- Effect: Determines the special effect to the video clip.
- SwapCam: Determines the switch camera(internal&External).
- Duration: Determines the duration.
- Sound: Determines the sound when the video camera is recorded
- Mirror: Determines the Mirror.
- Memory: Determines the memory.

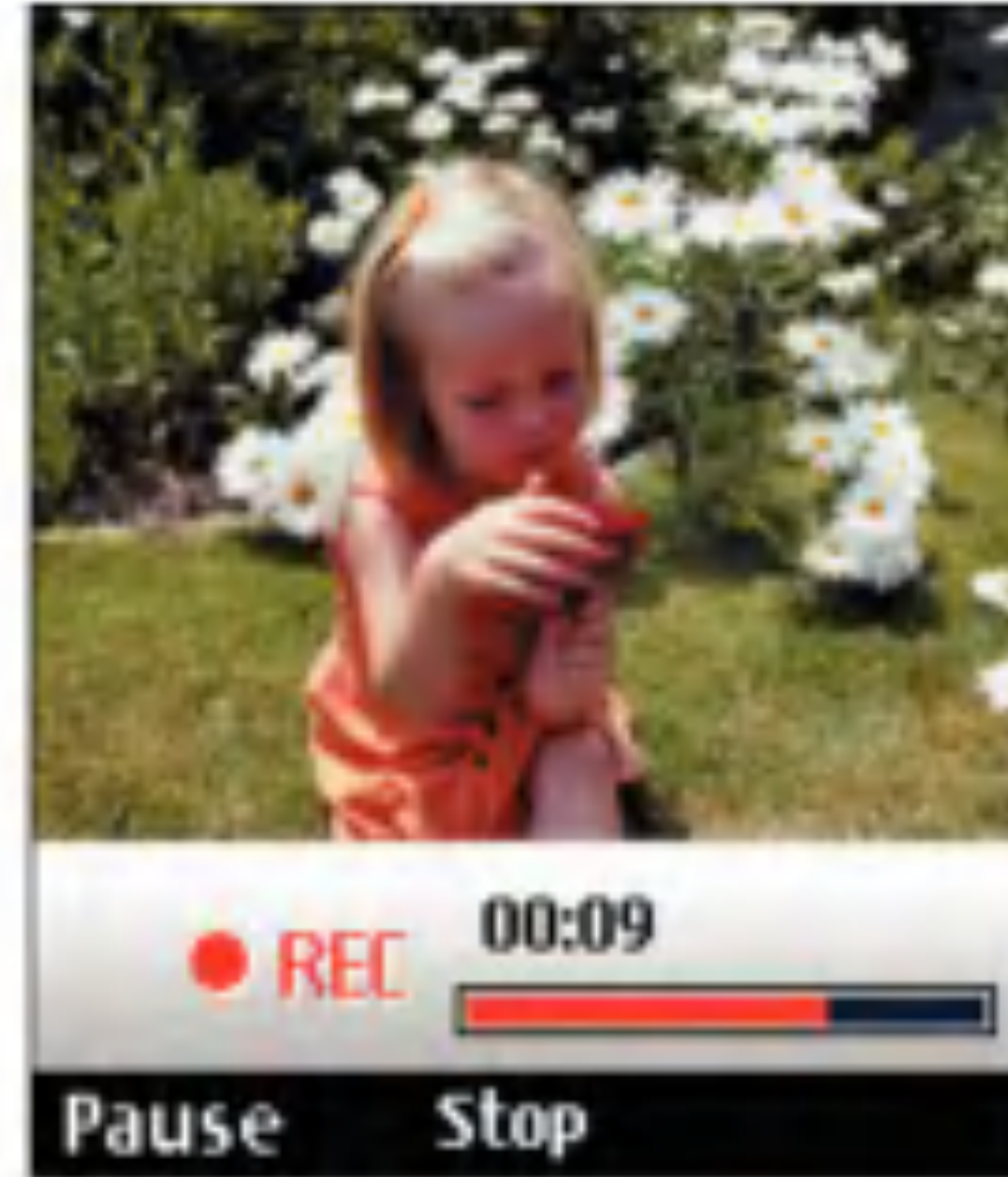

Camera

This application enables you to take a still picture. You can take a picture in your desired size, and use it for the contacts photo, home screen and other more general purposes. Once taken, a still image can be sent by Multimedia msg or Email.

Press the left soft key [Options] to display the following popup menu items.

- Size: Determines the size of an image.
- Quality: Determines the quality of an image.
- Light: Determines the light operation.
- Multishot: Determines whether to enable multi-shot photography.
- Zoom: Determines the zoom rate.
- Brightness: Determines the brightness.
- WB: Determines the white balance.
- Night mode: Determines the night mode.
- Timer: Determines the delay time.
- Effect: Determines the special effect to the picture.
- Mirror: Determines the Mirror



- SwapCam: Determines the switch camera(internal&External).
- Sound: Determines the sound when the shutter is pressed.
- Memory: Determines the memor

Notice

When you take a picture in 1280x960, 640x480, 320x240 and 160x120 size, you can see the added area on both sides of the screen compare with the preview image .

Multimedia

Voice recorder

This function allows you to record a voice memo. You can record voice messages with each message up to 30 seconds.

Press the left soft key [Options] to display the following popup menu items.

- Quality: Determines the quality of a recorded voice.
- New recording: Determines the recording a new voice.
- My stuff: Show the voice lists recorded.

Play lists

This option enables you to view a list of saved audio files.

You can add an audio file stored in your phone and memory card.

Press the left soft key [Options] to display the following popup menu items.

- Play: Plays the selected audio file.
- Add new: You can add a new file from the sound list.

- Edit: You can edit the selected file.
- Delete: Deletes the selected file.
- Delete all: Deletes all the stored audio files in the list.
- Set repeat: Select desired repeat mode using the navigation key.
- Rename: You can rename the selected file

Settings

Video camera

For further details, see the page 102.

Camera

For further details, see the page 103.

Voice recorder

Allows you to set the duration and quality for recording the voice by using the left/right navigation key.

Memory status

For further details, see the page 69.



Contacts

This menu allows you to save and manage contact address information. The Contacts functions provide functions to add a new address or search saved contact addresses by name, phone number and group information.

Add new

This menu allows you to add a new contact address. You can input contact address information including name, phone numbers, email addresses, group information items, memo, homepage address, ringtone, and avatar or image (photograph).

You have to select Handset or USIM card memory using the left and right navigation keys.

Search

This menu allows you to search your contact addresses. Generally the search operation is performed by name & number. In the search window, the current search function and results for the search condition are displayed.

On the screen, a saved image or avatar is displayed for the selected contact address. You



can change the configuration in the Show image/avatar(Menu 8.7.2) menu so that no image or avatar is displayed. You can also make a phone call or send a message to the selected phone number.

Speed dials

This menu allows you to configure speed dial numbers. You can select a number as a speed dial from 3 to 9. You can configure speed dial numbers for any of the 7 numbers for a specific contact address so that a contact address may have multiple speed dial numbers.

Group

This menu allows you to manage group information. By default, there are 4 groups: family, friends, colleagues and school. You can also configure ringtone for a group so that the group ringtone sounds when a call from a specific contact address within that group arrives and there is no ringtone configured for the contact address.

Service dial numbers

This menu allows you to make a call to one of the numbers provided by 3 Customer Service by moving the highlight to the desired number and pressing the  key. (E.g. 3 customer service, mail, 3 customer finance, etc.)

Own number

Allows you to display your phone number in the USIM card.

Settings

Allows you to set the display way as for the following items.



Display data

Handset & USIM / Handset / USIM

Show image/avatar

On / Off

Copy all

This menu allows you to copy all information from your USIM card, e.g. name, handset number, etc., to your handset. If a name is duplicated during the copying operation, the information is duplicated.

Contacts

- Handset to USIM: You can copy the entry from the handset memory to the USIM card (not all the data will be copied).
- USIM to handset: You can copy the entry from the USIM card to phone memory.

Move all

This menu allows you to move all the information from your USIM card, e.g. name, handset number etc., to your handset. This differs from the Copy all operation in that the target information is saved only in the destination location.

- Handset to USIM: You can move the entry from the phone memory to the USIM card.
- USIM to handset: You can move the entry from the USIM card to phone memory.

Clear contacts

This menu deletes contact address information. You can delete contact addresses saved in the handset memory and you can delete the numbers saved on the USIM card.

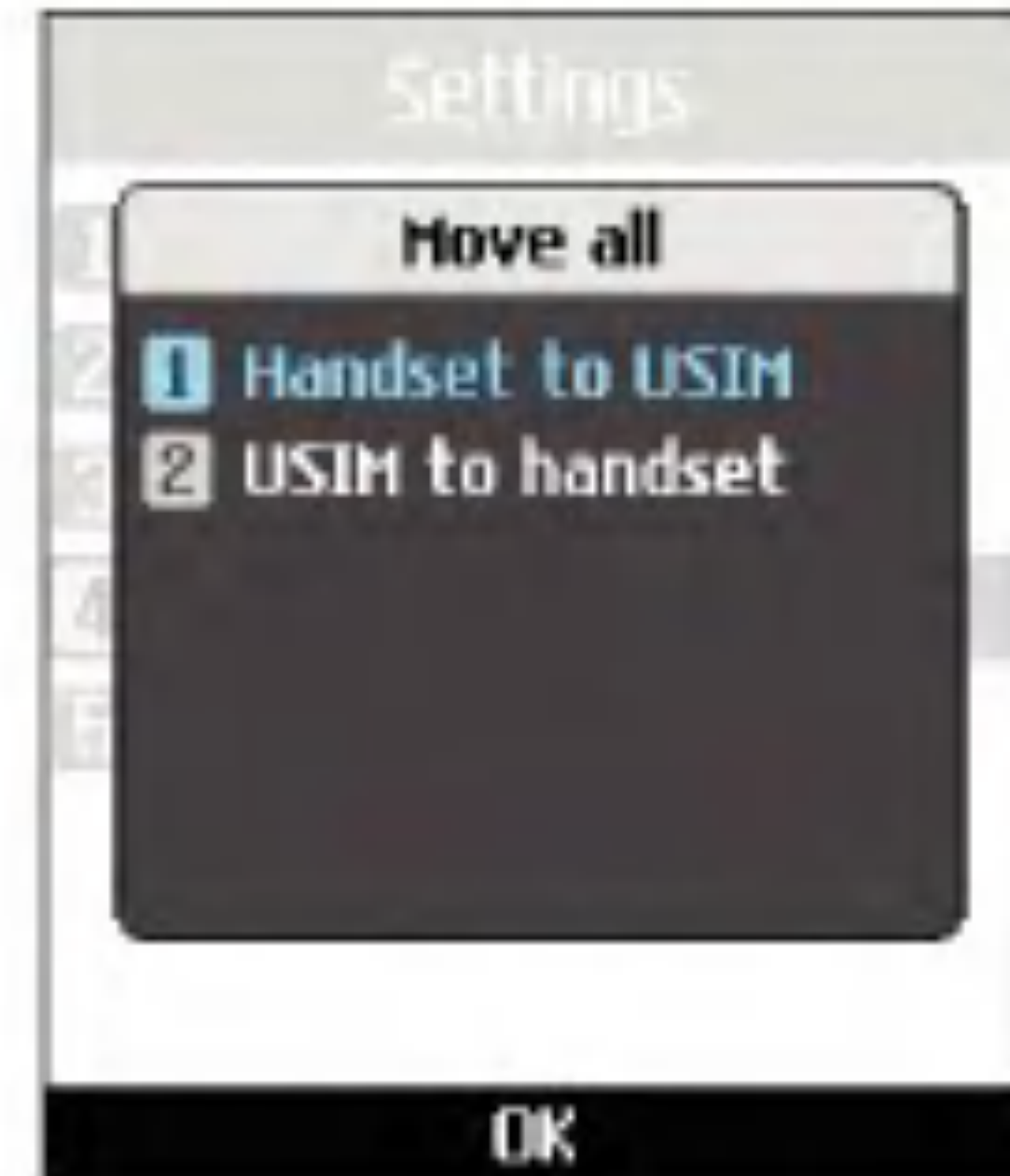



Applications

This Handset supports Java™ so that you can download games from Today on 3, and play them on your handset.

Games can be downloaded from the game page of the H3G portal site. Users can go to that page using the  key.

The  key loads the H3G portal page.

Select the services icon before users should select the game icon in the main page. (usually it is the page that appears when a user selects the tab beside "Today on 3") In the game page, users can view the game list, select, and download games. Or, users can use the Download applications menu to go to the game page.

Note

Please note that downloading a game usually requires additional charge.

My applications

This menu is used to locate and run downloaded applications, e.g. games. Select Download to view the list of applications that have been downloaded to the handset.

Download applications

This menu is used to go directly to the game download page, so that users can browse and select the games to download. This is possible because the Internet browser is launching with the game portal URL setting. This URL is specified in the Settings menu - Java Portal URL.

By default, the setting is on the game page of the H3G portal (or, it can be left blank if the Operator does not specify the URL). If users want to change the default setting, the game portal URL can be modified in the Settings menu.

Settings

This menu is used to configure the Java Internet portal site to connect to in order to download applications.

If this menu is selected, the list of currently saved Java Internet portal sites and the configured  displayed.

The first Settings screen: Shows the item list if there are saved items.

1. Select an item using the up or down navigation keys.
2. Press the  key to activate the selected item service.
3. Press the left soft key [Options] to display the popup menu.

Press the left soft key [Options] to display the following popup menu items.

- Activate: Activates the selected item.
- Add new: New profile is added.
- View: Shows the contents of the selected item.

Organiser



Organiser

Calendar



Monthly Schedule Management

1. Select the Organiser from the top menu.
2. Select Calendar and press the  key.
3. The monthly schedule view is displayed.
4. Initially, the cursor appears on today's date according to your handset settings.
5. You can move the date cursor to the desired location using the up, down, left and right navigation keys.
6. On a date where a schedule item, anniversary or birthday is saved, corresponding icons and the number of saved schedule items are displayed on the bottom left of the screen.

Adding a New Schedule Item

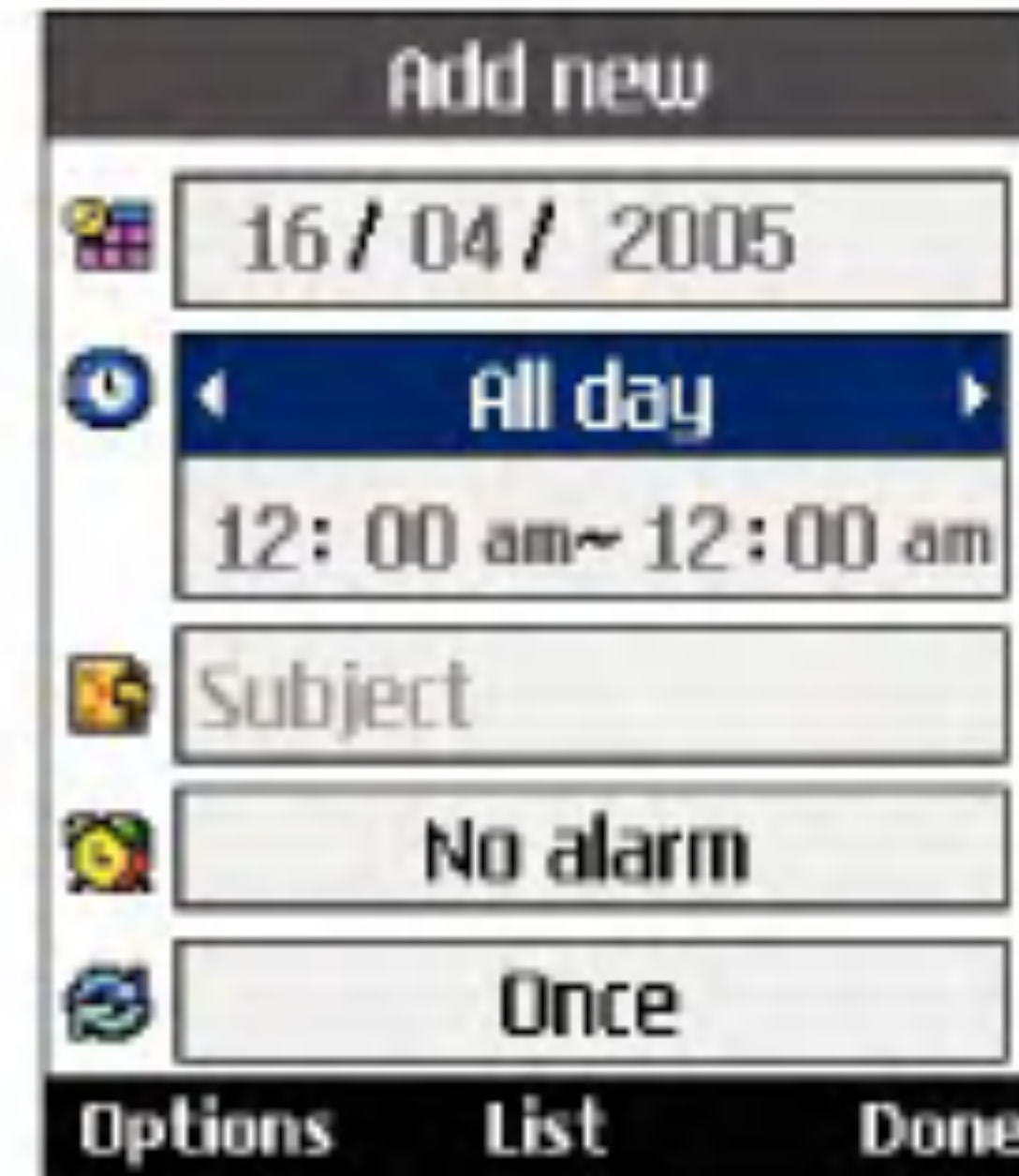
1. Select the left soft key [Options] in the Monthly schedule management screen, select the Add new from the popup menu and then press the  key. Alternatively, select the right soft key [Add] in the Monthly schedule management screen.



2. Input the desired date using the numeric keys.
3. Input the desired time using the numeric keys.
4. Input the subject and press the  key.
5. Select the schedule item type using the left and right navigation keys.
6. Select the repeat type using the left and right navigation keys.
7. Select the alarm type using the left and right navigation keys.
8. Press the  key to save the new schedule item.

Deleting a Schedule Item

1. Select the left soft key [Options] in the Monthly schedule management screen, select Delete, and then press the **OK** key.
2. Popup menus including Previous entries and All entries will be displayed.
3. Select Previous entries and press the **OK** key to delete all schedule items prior to today.
4. Select All entries, and press the **OK** key to delete all of the schedule items.

Set holiday

1. Select the left soft key [Options] in the Monthly schedule management screen, select Set holiday and then press the **OK** key to display the Holiday configuration popup window.
2. Supported holiday types include On the day, Weekly, Monthly, Annually and Multiple setting.
3. Select the holiday configuration type and press the **OK** key to configure the holiday.

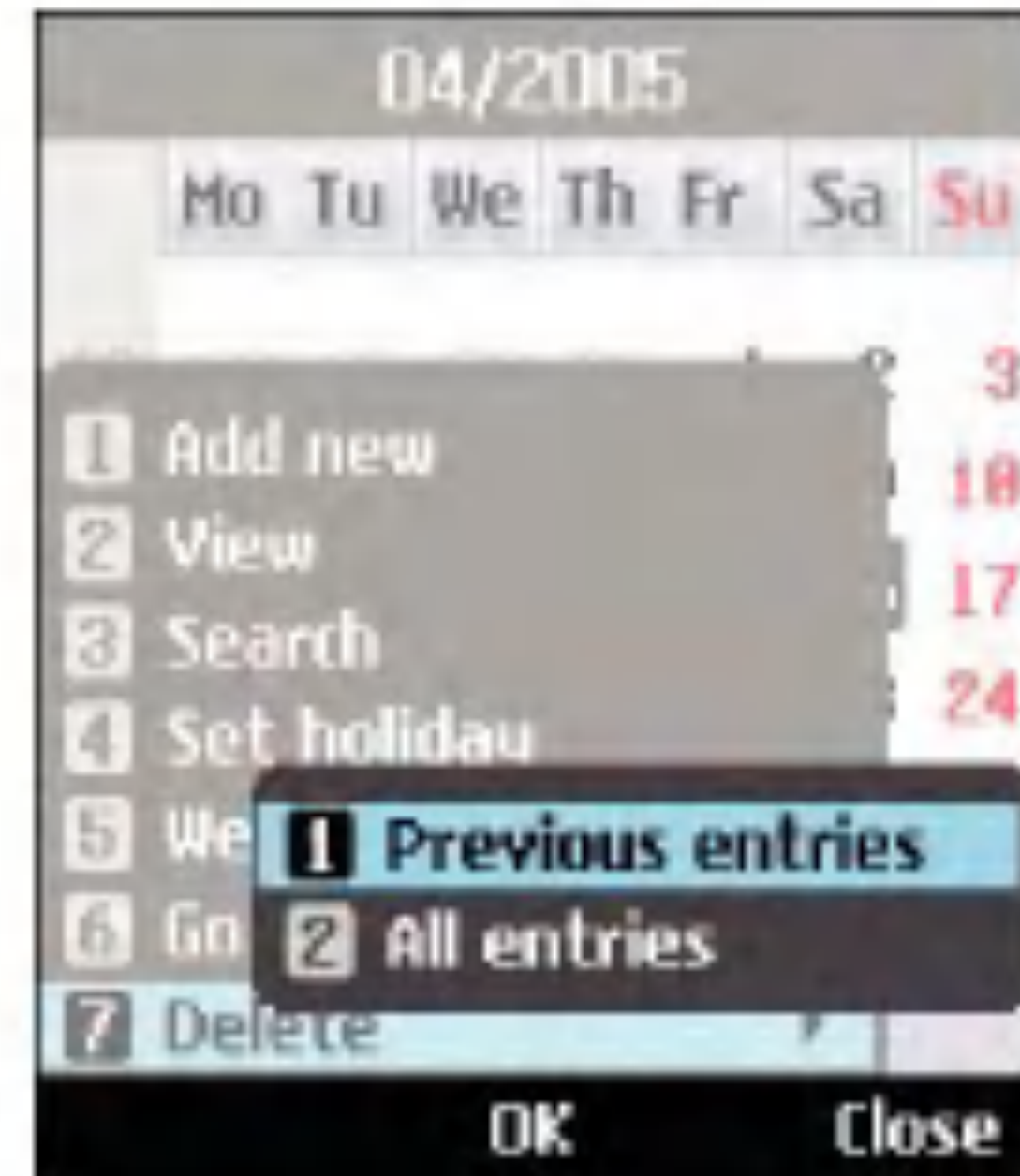

4. The date corresponding to the configured holiday is represented in green in the Monthly schedule management screen.

Organiser

Searching for a Schedule Item

Select the left soft key [Options] in the Monthly schedule management screen, select Search and then press the **OK** key to display the Search schedule items screen.

1. Input the desired subject of the schedule item to find.
2. Select the In type to find.
3. Press the **Enter** key.
4. If there are schedule items that meet the search criteria, the schedule items are displayed. If there is no schedule item satisfying the search criteria, No match schedule Item message appears.

Moving to a Specific Date

1. Select the left soft key [Options] in the Monthly schedule management screen, select Go to date and then press the **OK** key to display Go to date window.
2. Input the desired date to move to and press the **OK** key.



3. The date cursor of the Monthly schedule management screen will then move to the specified date.

To do

To do Enquiry

1. Select the Organiser from the top menu.
2. Select the To do item and press the  key.
3. The saved To do list is displayed.

Adding To do Items

1. To add a new To do item, select Add new using the left soft key [Options] in the To do enquiry screen or select the right soft key [Add].
2. Input Date, notes and priority when you add an item.
3. Press the right soft key [Done] to save the To do item.

To do Delete

1. Select the desired item(s) to delete from the To do list and press the Delete using the left soft key [Options] to delete the To do item.

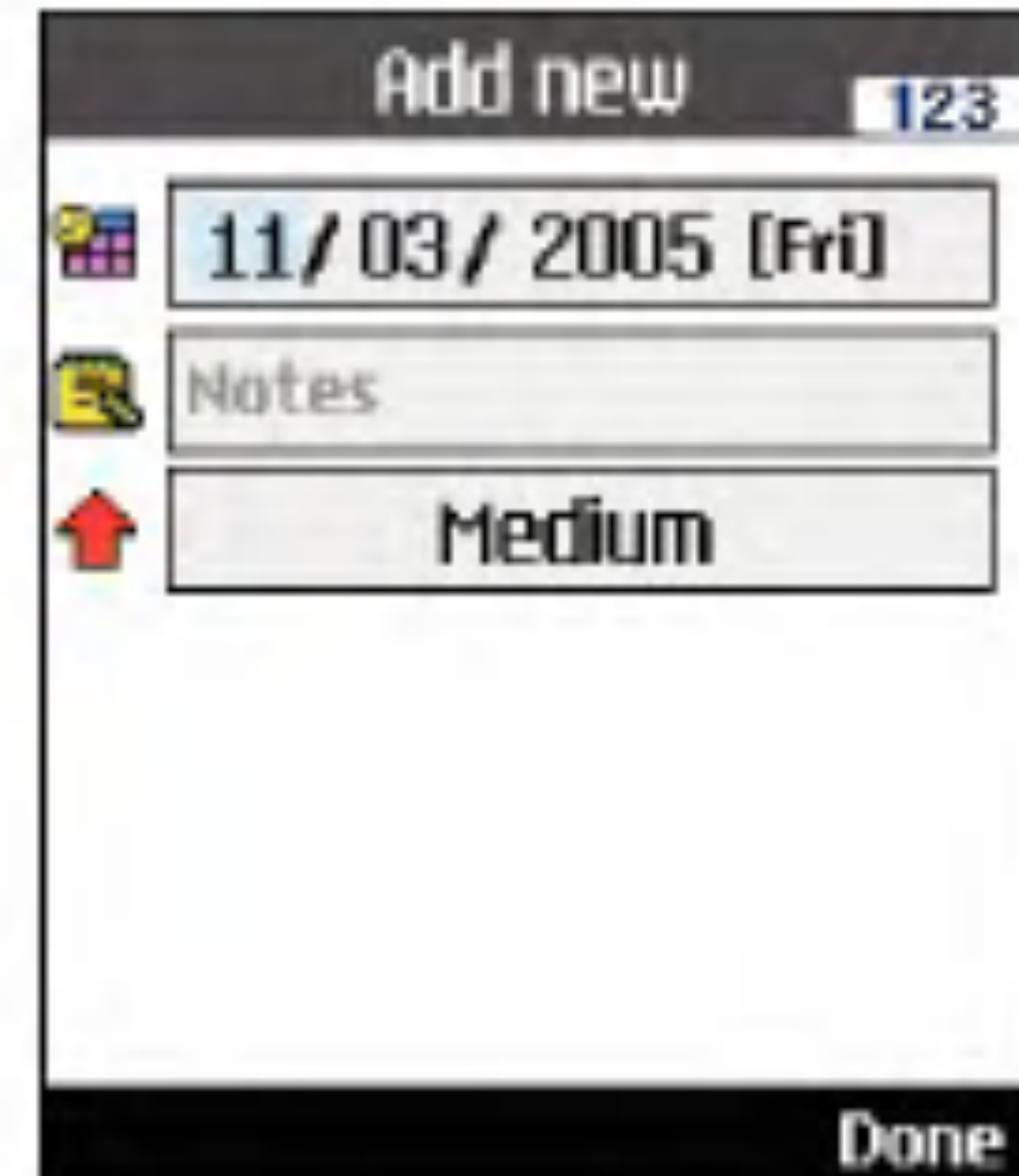

Finished/Not finished

1. If you wish to mark an item in the saved To do list as done, select the item from the To do list.
2. Select the Done using the left soft key [Options] to draw a line over the schedule item to mark it as done.
3. To cancel Done, select the Not yet done.

Mark/Unmark

1. You can Mark/Unmark desired (all) item(s) from the list.
2. By this option you can delete marked items.

Organiser

To do Detailed View

To view detailed information, select the desired item from the To do list and press the  key to display the detailed view screen about the item.

Memo

Saved Memo's

1. Select the Organiser from the top menu.
2. Select the Memo item and press the  key.
3. The saved memo list is displayed.

Memo Add

1. To add a new memo, select Add new using the left soft key [Options] in the General memo screen or select the right soft key [Add].
2. Input the contents of the memo to be saved.
3. Press the  key to save the memo.

Memo Lock/Unlock

1. Select the desired item to lock from the



saved memos list. The locked memo is converted to a secret memo.

2. Select Move to secret memo using the [Options] key to lock the memo item.
3. To release the lock again, select Move to memo in the Secret memo item.

Memo Edit

You can edit the selected memo.

Memo Delete

1. Select the desired item(s) to delete from the Memo list and select Delete using the left soft key [Options] to delete the memo.

Secret memo

1. Select the **Organiser** from the top menu.
2. Select the **Secret memo** item and press the **OK** key.
3. To view or delete the memo set up as a secret memo, you have to input the password configured in the phone.

Date finder

The date finder shows the number of remaining days while changing the day.

Dateulator

■ Dateulator enquiry

1. Select the **Organiser** from the top menu.
2. Select the **Dateulator** item and press the **OK** key.
3. The saved **Dateulator** list is displayed.

■ Adding Dateulator items

1. To add a new **Dateulator** item, select **Add new** using the left soft key [Options] in the **Dateulator** enquiry screen or select right soft key [Add].



2. Input the Date, and notes when you add an item.
3. Press the right soft key [Done] to save the item.

■ Mark/Unmark

1. You can Mark/Unmark desired (all) item(s) from the list.
2. By this option you can delete marked items.

■ Dateulator Delete

Select the desired item(s) to delete from the **Dateulator** list and press the **Delete** using the left soft key [Options] to delete the **To do** item.

Organiser

■ Dateulator Detailed View

To view detailed information, select the desired item from the Dateulator list and press OK key to display the detailed view screen about the item.

■ Show home screen/ Do not show home screen

By setting Show home screen, you can see the Remaining days for this item (D-Day) on Idle screen top left corner.

Settings

Calendar

You can change Calendar Default view and Week start time to desired options. Press right soft key [Done] to save settings in phone.

Memory info.

Allows you to view each memory status of the organiser menu.



Clear all

Allows you to delete all the saved items, you need to input the security code.



Tools

Quick menu

Quick menu allows you to add your own favourites to the list already provided. Once you create your own menu, you can access the desired function quickly in the idle screen by pressing the up navigation key. To move to your desired menu directly, select your desired menu from the Favourites menu press the up and down navigation keys.

- **Add new:** In the [Empty] list, press the right soft key [Add]. Select the item from the menu and save the desired menu item.
- **Open:** In the added menu items list, press the left soft key [Options] or the center soft key. To move to your desired menu directly.
- **Edit:** In the added menu items list, press the right soft key [Edit] or the left soft key [Options]. Select Edit from the menu to edit a saved menu item.
- **Delete:** In the added menu items list, press the left soft key [Options]. Select Delete from the menu to delete a saved menu item.
- **Delete all:** In the added menu items, press the left soft key [Options]. Select Delete all



from the menu to delete Quick menu items 7 to 0.

- **View info.:** In the added menu item list, press the left soft key [Options].

Select View info. from the menu to view the information about the actual location of the added menu item.

Alarm clock

The alarm function allows you to set up multiple separate alarms. You can also set the time, repetition interval and alarm sound.

- Select your desired alarm to configure in the alarm list. If there is no alarm, press the right soft key [Add] to add a new alarm.
- Set/Cancel alarm: Select desired set time mode using the navigation key.
- Input alarm time: Input your desired alarm time by specifying hour and minute. If the time format is 12 hours-based format, you have to select either 'am' or 'pm' using the  key.
- Select repeat mode: Select desired repeat mode using the navigation key.
- Select bell: Select the bell to use for the alarm using the navigation key.
- Input memo: Input alarm name.

When you have completed configuration, press the  key to save the changed alarm configuration.



Note

The alarm function does not work if the handset is turned off.

Tools

Connectivity

Bluetooth

Paired devices

Select the Paired devices by pressing the OK key. This function allows you to view the list of all devices that are paired with your phone at once.

- Adding a new device
 1. Select the Add New to search the device can be connected in range.
 2. If you want to stop the searching, press the right soft key [Cancel].
 3. All of the searched devices are displayed the popup menu.

Select the desired device by pressing the OK key, and input the password.

- Assigning a short name

Press the OK key, to rename the paired device.
- Connecting/Disconnecting the device
 1. Select the Connect, allows you to active to the bluetooth connection.

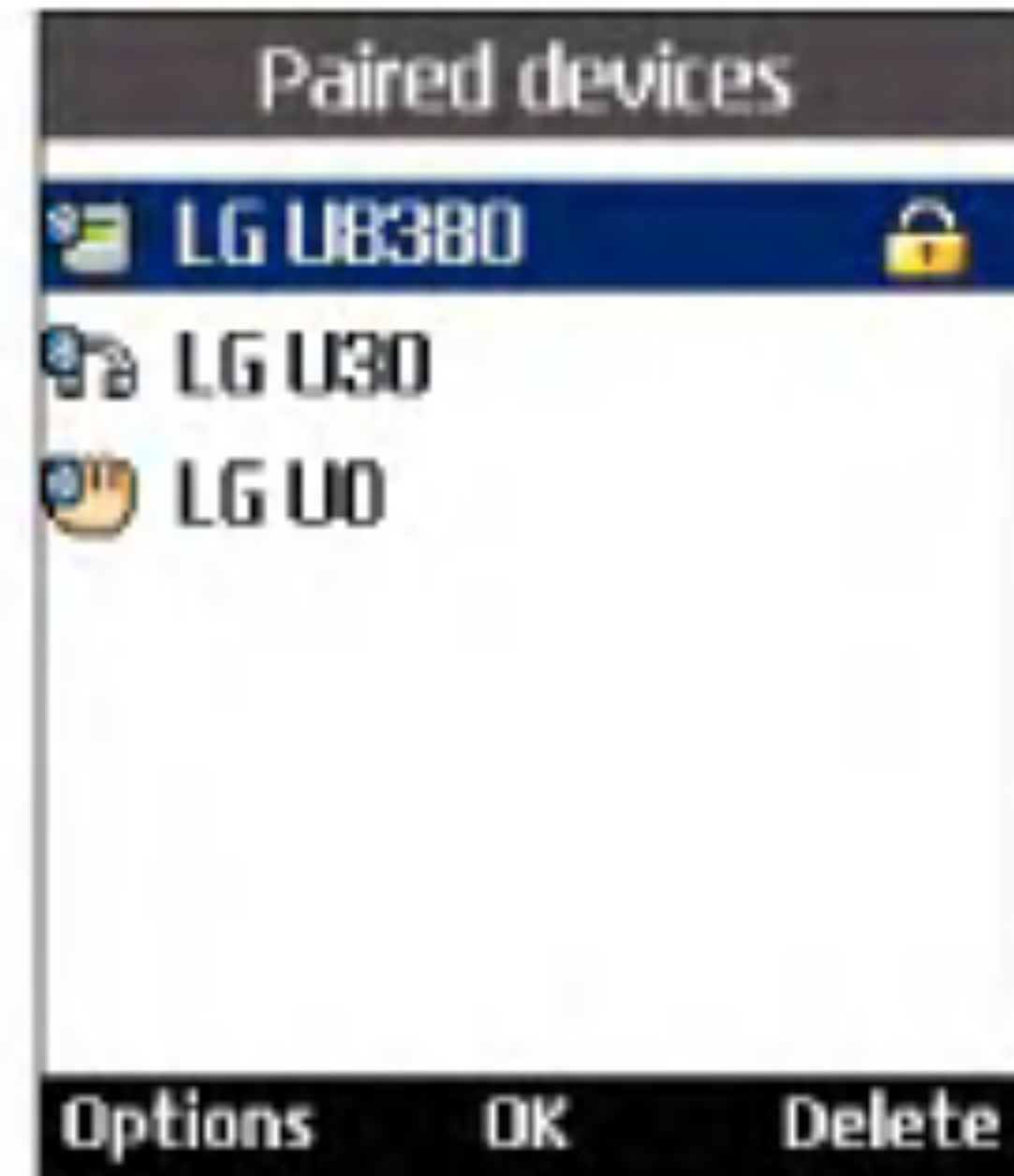

2. If you want to close the connection to the selected device, select the Disconnect.

Note

This options is appeared when the device connected with your phone is the headset.

- Deleting devices

Select Yes to delete the selected device.
- Deleting all the devices

Select Yes to delete all the devices in the list.

Settings

This menu allows you to configure the profile for a bluetooth.

- Bluetooth usage

Set on or off the bluetooth using the left/right navigation key.

- My handset's visibility:

1. Select the Shown to all, shows your phone to other bluetooth devices.
2. Select the Hidden, shows your phone only to the paired device.

- My Handset's name

Allows to you change the handset's name can be seen by other bluetooth devices.

Server synchronisation

The Server sync function synchronises the data in a phone and the data on a server such as contact address information, schedule items, etc. via a wireless network.

Connect

Select Server sync from the Tools menu and then press the **OK** key.

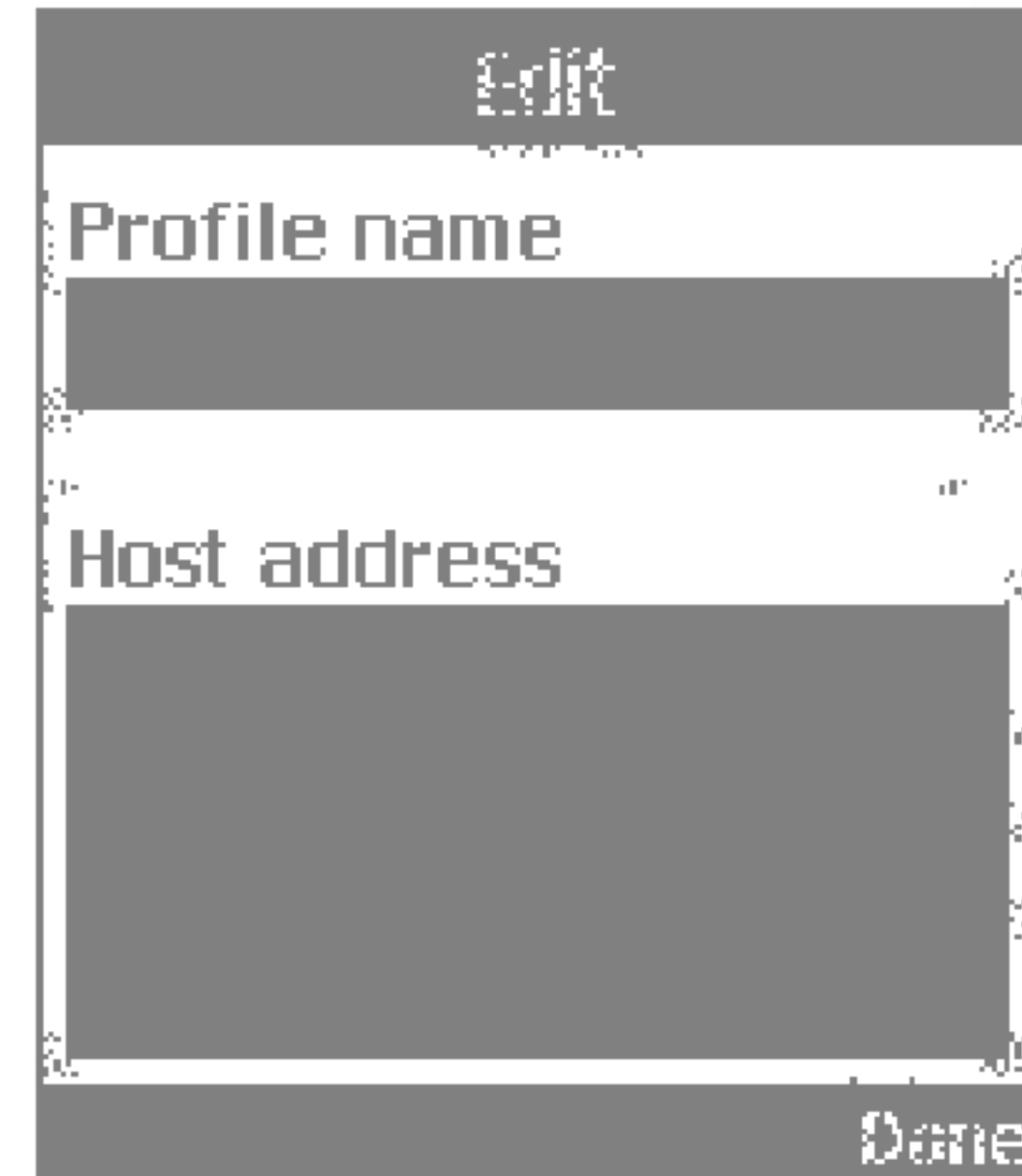

Select the Connect item and then press the **OK** key.

Connect to the server with the selected server profile and the synchronization animation is displayed while the synchronization is performed.

Log

Select a Server sync item in the Tools menu and then press the **OK** key. Select Log item and then press the **OK** key to view the log for the last synchronisation operation performed.

Tools

Server synch centre

This menu allows you to configure the profile for a Sync Server.

■ Adding a new profile

1. Input and choose the Profile name, Host address, Username, Password, Contacts, Contact name, Calendar, Calendar name, To do, To do name and Access point.
2. Press the  key to save the new profile.
3. In the Settings screen, press the left soft key [Options] key and select Add new to add a new profile.

■ Editing a profile

1. Select a profile to edit.
2. Press the left soft key [Options], select Edit, and edit the selected profile.

■ Deleting profiles

1. Press the left soft key [Options] and select Delete.
2. Select Yes to delete the selected profile.

■ Selecting a server

Select a desired server profile to synchronise



in the Settings screen and then press the  key.

Calculator

The calculator function allows you to add, subtract, multiply and divide. You can input numbers using the number keys, and operators using the up, down, left, and right navigation key.

You can input a decimal point by pressing the  key.

Whenever you press the  key, characters are sequentially deleted in reverse direction.

World time

The World time function provides time information on major cities worldwide.

1. You can view the time of desired country or city using the navigation or  [List].
2. You can select a desired city as a base using the right soft key [set].

Unit converter

This function converts any measurement into a unit you want.

There are 7 types of units that can be converted: Currency, Surface, Length, Weight, Temperature, Volume, and Velocity.

Note

You can input a decimal number by pressing the  key.

Currency

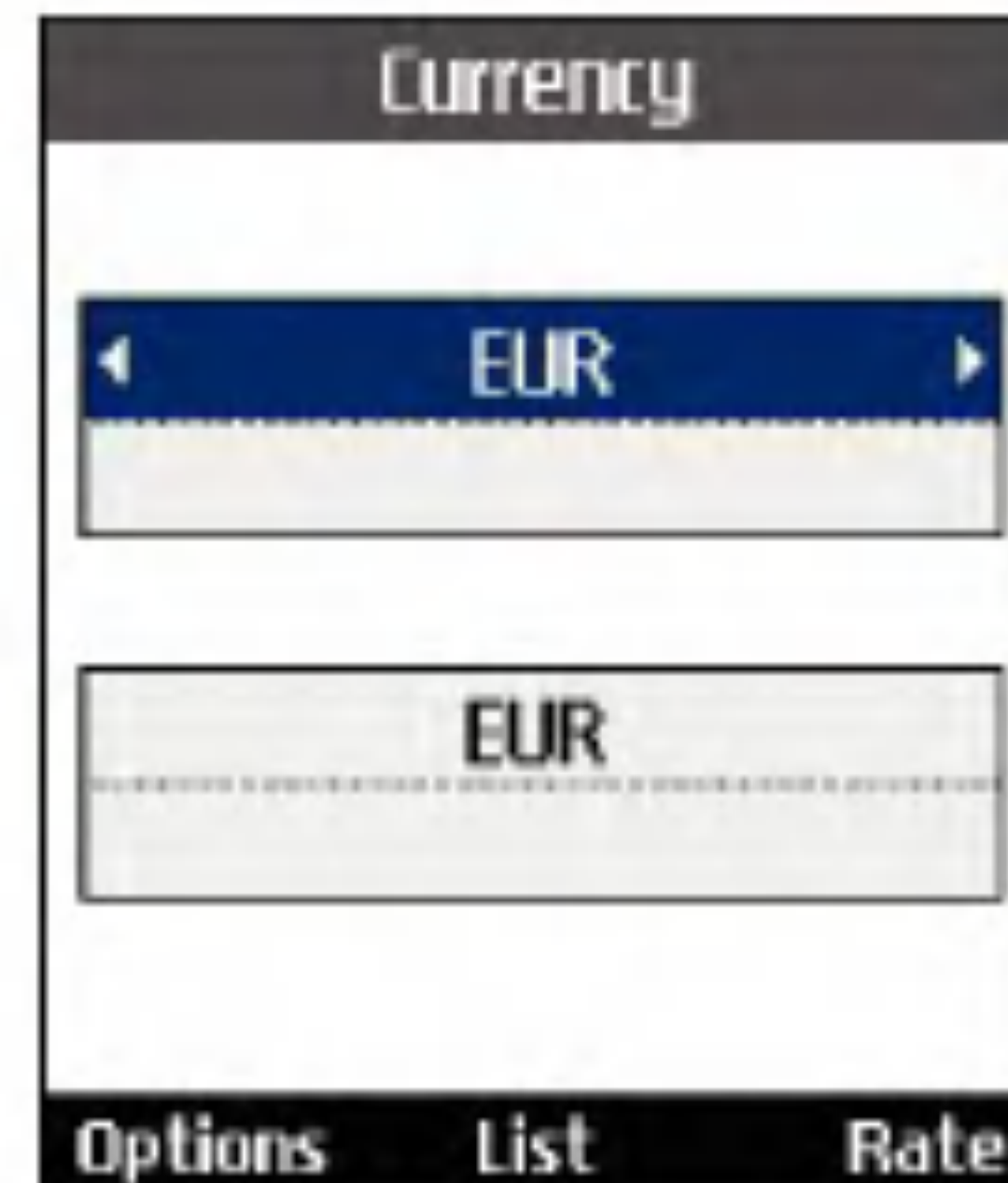

1. Select the Currency menu.
2. Users can set a currency exchange rate using the right soft key [Rate].





3. Input standard unit to view converted value.
4. You can view the value in home country currency unit in Domestic by inputting standard unit in Foreign.
5. Press the right soft key [Reset] to clear the current input field, and locate the cursor in the input field.
6. To exit currency conversion function, press the  key.

Tools

Surface



1. Select Surface menu.
2. Select desired unit to convert using the  key [Unit].
3. Input standard unit to view converted value.
4. Press the right soft key [Reset] to clear the current input field, and locate the cursor in the input field.
5. To exit area conversion function, press the  key.

Length

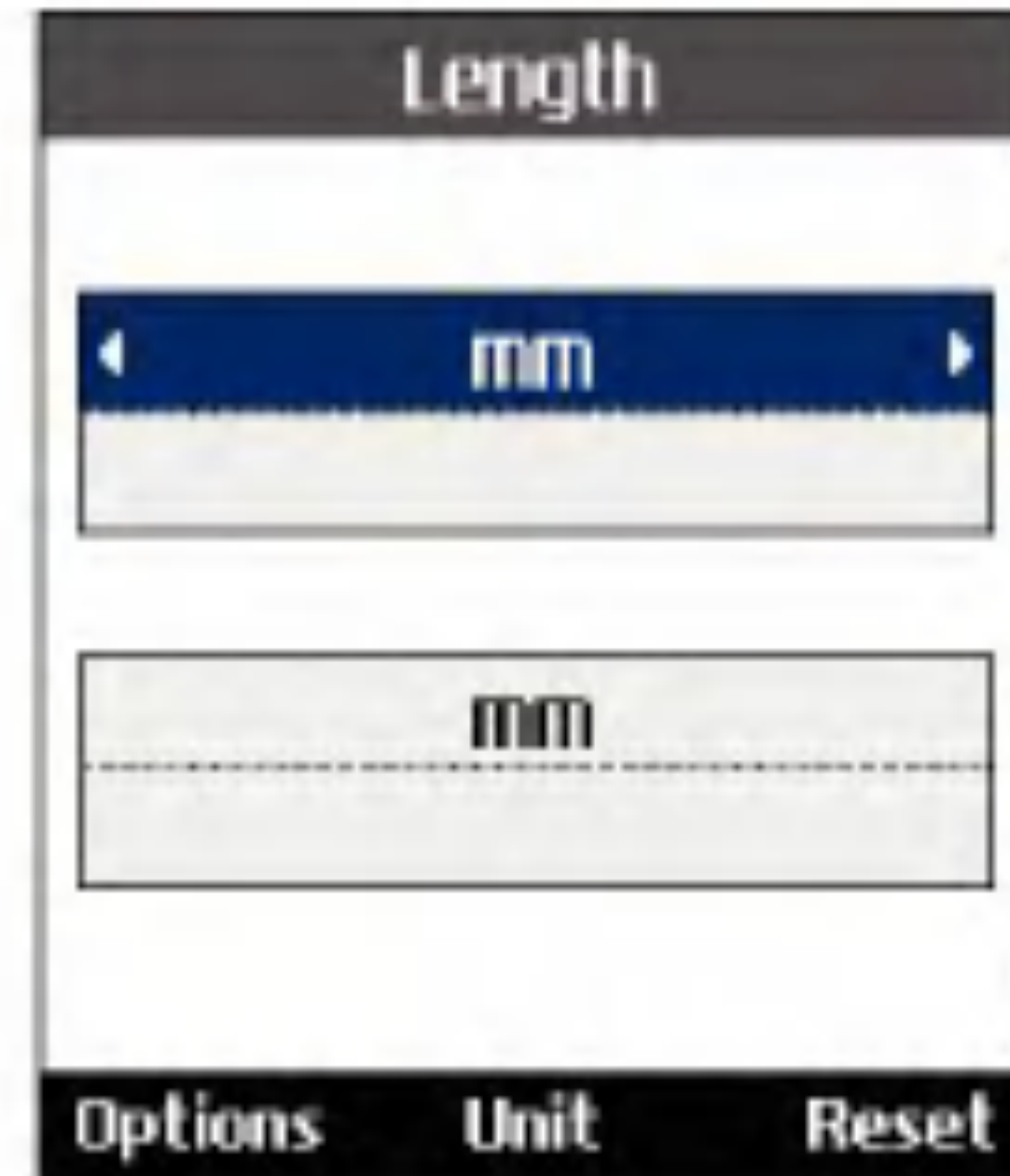
1. Select Length menu.
2. Select the desired unit to convert using the  key [Unit].
3. Input the standard unit to view converted value.
4. Press the right soft key [Reset] to clear the current input field, and locate the cursor in the input field.
5. To exit length conversion function, press the  key.





Weight

1. Select Weight menu.
2. Select desired unit to convert using the  key [Unit].
3. Input the standard unit to view converted value.
4. Press the right soft key [Reset] to clear the current input field, and locate the cursor in the input field.
5. To exit weight conversion function, press the  key.

Temperature



1. Select Temperature menu.
2. Input the standard unit to view converted value.
3. Press the right soft key [Reset] to clear the current input field, and locate the cursor in the input field.
4. To exit temperature conversion function, press the  key.

Volume

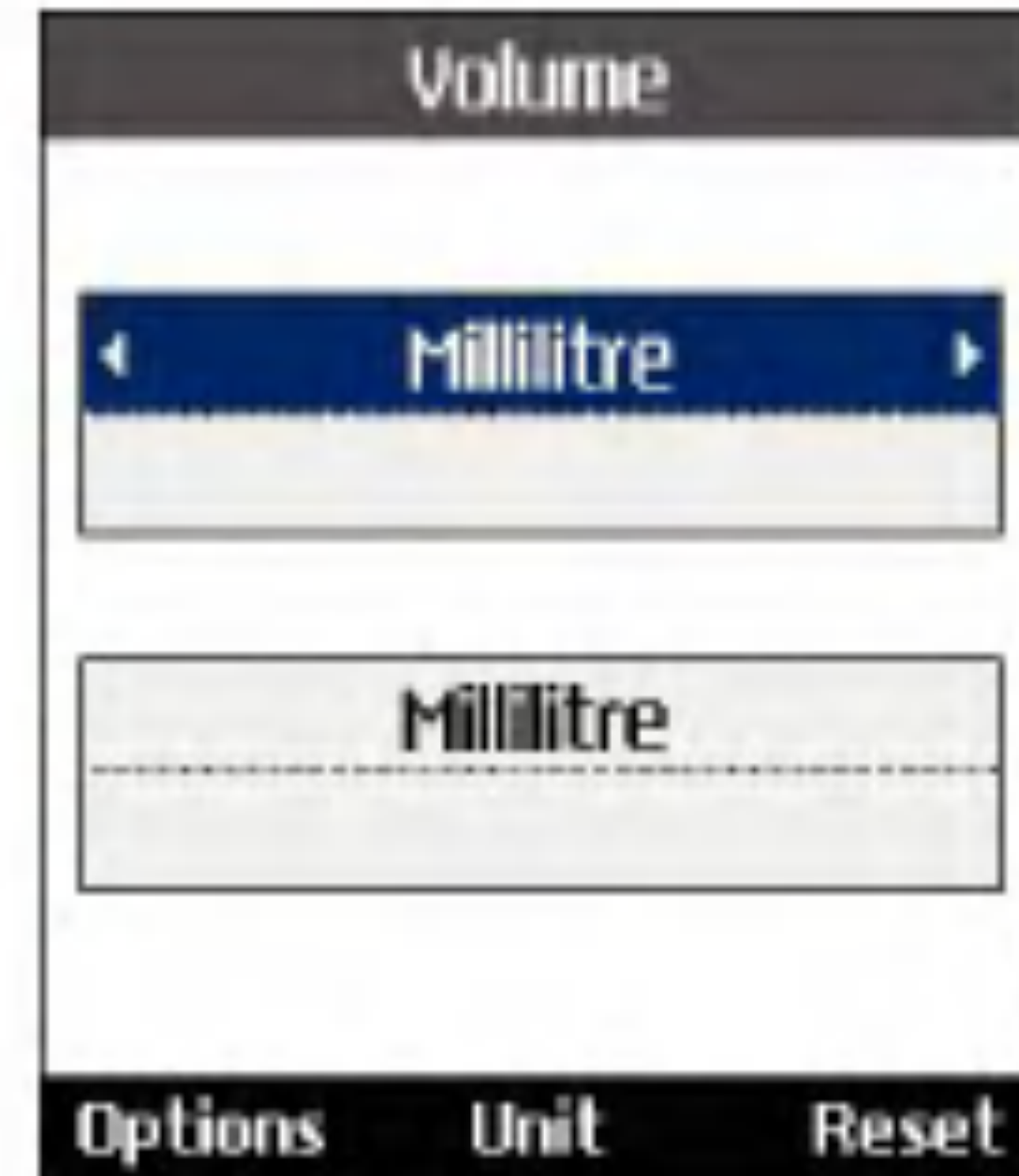
1. Select Volume menu.
2. Select desired unit to convert using the  key [Unit].
3. Input the standard unit to view converted value.
4. Press the right soft key [Reset] to clear the current input field, and locate the cursor in the input field.
5. To exit volume conversion function, press the  key.



Velocity

1. Select Velocity menu.
2. Select desired unit to convert using the  key [Unit].
3. Input the standard unit to view converted value.
4. Press the right soft key [Reset] to clear the current input field, and locate the cursor in the input field.
5. To exit velocity conversion function, press the  key.

#.Calling



Calling

Video calls

My picture size

This menu allows you to configure your own picture size to either Large, Medium or Small.

My picture position

This menu allows you to configure your screen alignment to bottom right or bottom left.

Hide my picture

This menu allows you to hide your picture.

Mirror



This menu allows you to configure mirroring of your picture.

Substitute Picture

This menu allows you to substitute your picture with another picture.



Call history

You can access the call register by pressing the  key or the  key. Different icons show you the type of the recent calls registered in the list (see following page for icon description).

- You can view missed, received, dialled and entire call records. Each call record menu provides the following functions.
- You can make a voice or video call to the number in the call record.
- You can save the number in the call record to the Contacts.

- You can send a message to the number in the call record.
- You can view detailed information about the call records such as the date, time and call duration.
- You can clear call records.

Missed calls

Allows you to view missed call records, make a call, send a message and save the number in the Contacts.

Received calls

Allows you to view received call records, make a call, send a message and save the number in the Contacts.









Dialled calls

Allows you to view dialled call records, make a call, send a message and save the number.

All calls

This menu allows you to view all of the missed, received, and dialled call records. You can make a call, or send a message to the number

you have selected from the records. You can also save the number in the Contacts.

-  Received video call
-  Dialled video call
-  Missed video call
-  Reject video call
-  Received voice call
-  Dialled voice call
-  Missed voice call
-  Reject Call

Call duration

Shows call duration time by type. Press the right soft key [Reset] to reset. A security code will be requested.

Last call

Displays the duration of the last call made in hours/minutes/seconds.

Received calls

Displays received call duration.

Calling

Dialled calls

Displays dialled call duration.

All calls

Displays overall call duration.

Call costs

This network service allows you to check the last call cost, the total call cost and the remaining call cost. The call cost is displayed on the bottom of the LCD screen. To reset the call cost, select Reset all. You are requested to enter the PIN2 code.

Call divert

This menu allows you to configure the call divert service which diverts incoming calls to a user-specified number.

1. Press the  key in the idle screen.
2. Press the navigation key down to select Calling and press Call divert.



Voice calls

- All voice calls
Diverts all incoming voice calls unconditionally.
- If busy
Diverts incoming voice calls when the line is busy.
- If no answer
Diverts incoming voice calls when there is no answer.
- If unreachable
Diverts incoming voice calls when the handset is turned off or the handset is out of the network service coverage

Video calls

You can divert video calls to other 3 handsets that support video calling.

- **All video calls**
Diverts all incoming video calls unconditionally.
- **If busy**
Diverts incoming video calls when the line is busy.
- **If no answer**
Diverts incoming video calls when there is no answer.
- **If unreachable**
Diverts incoming video calls when the handset is turned off or the handset is out of the network service coverage.

All fax calls

Diverts fax calls unconditionally.

Call barring

Call barring allows you to restrict from making and receiving calls with your handset. For this

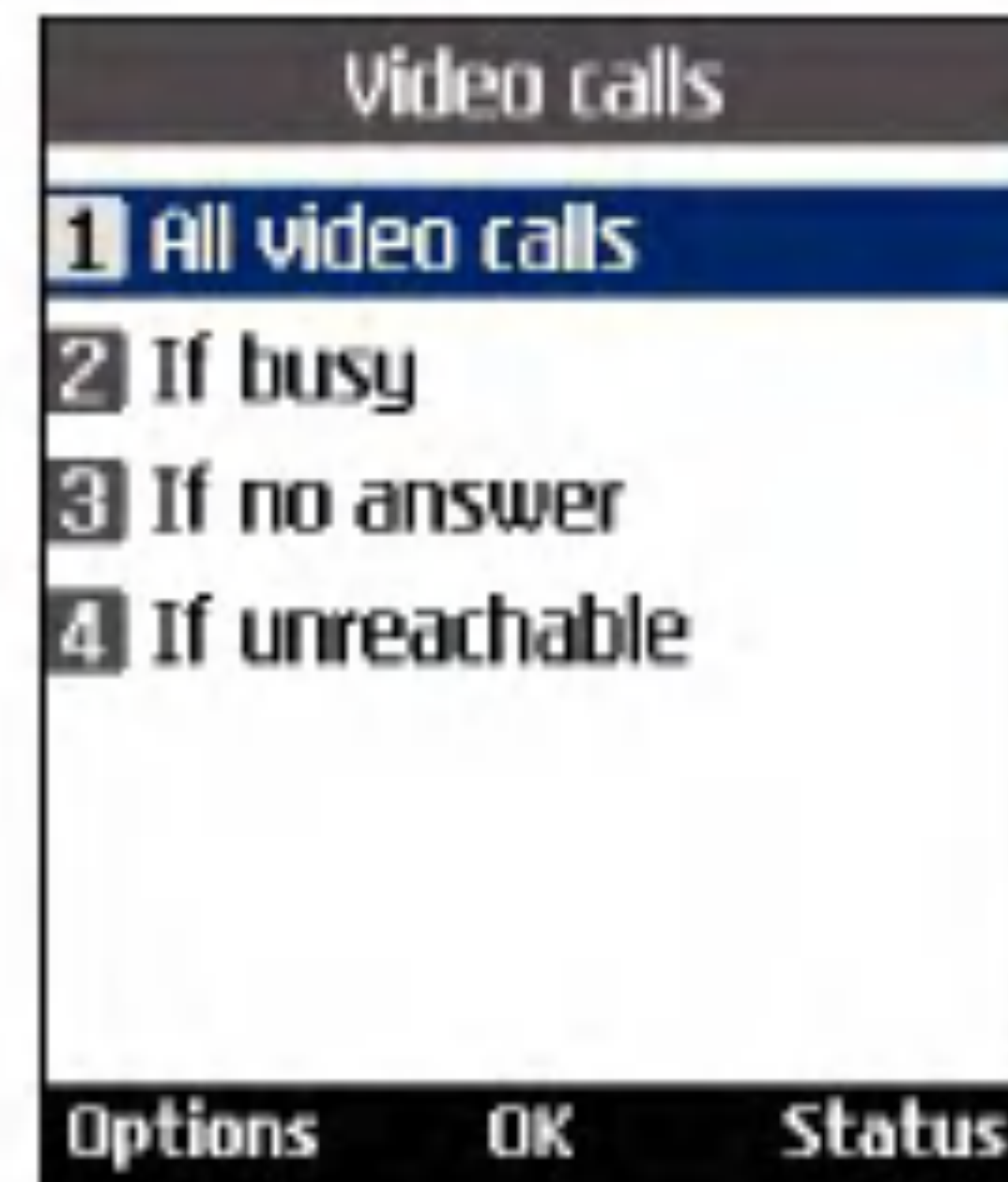

function, you need the barring password, which you can obtain from 3 Customer Service.

Voice calls

The following options are available:

- **All outgoing:** Calls cannot be made.
- **Outgoing international:** International calls cannot be made.
- **Outgoing international calls except home country:** When abroad, calls can be made only to numbers within the current country and to your home country, which is where your home network provider is located.

Calling

- All incoming: Calls cannot be received.
- Incoming when abroad: Calls cannot be received when you are using your handset outside your home service area.

Video calls

The following options are available:

- All outgoing: Calls cannot be made.
- Outgoing international: International calls cannot be made.
- Outgoing international calls except home country: When abroad, calls can be made only to numbers within the current country and to your home country, which is where your home network provider is located.
- All incoming: Calls cannot be received.
- Incoming when abroad: Calls cannot be received when you are using your handset outside your home service area.

Deactivate all

All call barring settings are deactivated; calls can be made and received normally.



Fixed dial numbers

You can fix dialling to specified phone numbers only. This information is saved on the USIM card. You must enter your PIN2 code for authentication.

- On: Enables Fixed Dial Numbers.
- Off: Disables Fixed Dial Numbers.
- Number list: You can view and edit the Fixed Dial Number list.

Call waiting

The network will notify you of a new incoming call while you have a call in progress. Select

Activate to request the network to activate call waiting, Deactivate to request the network to deactivate call waiting, or View status, to check if the function is active or not.

Settings

Call reject

This menu allows you to enable or disable rejection of all calls or calls categorized as Unregistered, Contacts or Groups.

■ Reject On/Off

To Enable or Disable the Call Reject

■ Reject List

To select the category of call reject numbers. You can select any of the following categories:

- **All Calls**

If this category is selected, all calls will be rejected

- **Contacts**

If this category is selected, all numbers in contacts list will be rejected

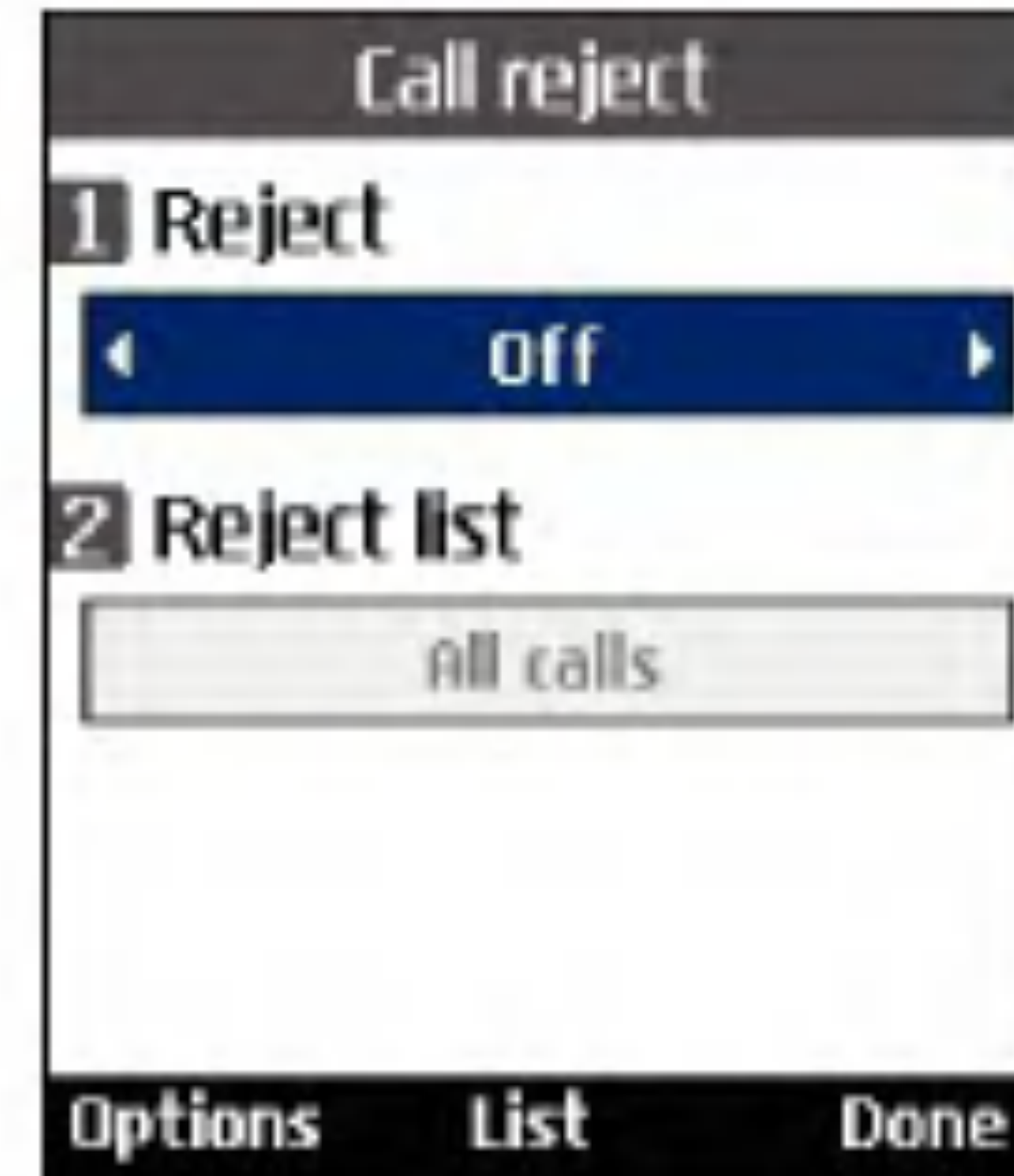

- **Groups**

If this category is selected, all numbers belonging to the selected groups will be rejected.

- **Unregistered**

If this category is selected, all un-registered numbers will be rejected.

■ Reject Group

If the Reject Category 'Groups' is selected from the Reject List, the group, which has to be rejected, can be selected here.

All the available groups will be listed here. Up to three groups can be selected for rejection.

Calling

Press the right soft key [Done] after configuring the Call rejection to save the changes and go back to previous menu.

Send my number



This network service allows you to set your phone number to be displayed **On** or hidden **Off** from the person whom you are calling. Select **Set by network** to reset the handset to the setting that you have agreed upon with 3 Customer Service.

Auto redial

The menu enables you to configure the auto redial function when a call attempt has failed.

Answer mode

Allows you to determine when to answer the handset.

- Press send key: You can answer an incoming call by only pressing the  key.
- Press any key: You can answer an incoming call by pressing any key, except the  key, soft keys and side keys.



- Open flip: This option allows you to answer a call simply by opening the flip.

Minute minder

This function sounds an alert notification every 1 minute after call connection.

And so on...

Troubleshooting

Please check to see if any problems you have encountered with the phone are described in this section before calling 3 Customer Service.

Q How do I view the list of outgoing calls, incoming calls and missed calls?

A Press the  key.

Q How do I view all numbers stored in memory?

A Press right soft key[Contacts] and then  or press the down navigation key.

Q Why is the connection inconsistent or not audible in certain areas?

A When frequency environment is unstable in a certain area, connection may be inconsistent and not audible. Relocate to another area and try again.

Q Why does the display not turn on?

A Remove and insert the battery, then attempt to power-on. If there is no change, fully charge the battery and try again.

Q Why is there an echo when a connection is made with certain telephones in a certain area?

A This is called the 'Echo Phenomenon', where it occurs if connection volume is too high or caused by special properties (semi electronic telephone exchange) of the equipment on the other end.

Q Why does the handset heat up?

A The phone may get hot when there is a very long call duration or when games are played or when using the browser. This has no effect upon the life of the product or performance.

Q Why is there no ringtone, but only a blinking LCD screen?

A Phone may be set to 'Vibrate only' or in 'Silent' mode. In the Profiles menu, please select 'Normal' or 'Outdoor'.

Q Why does the battery life get shorter in standby mode?

A The battery is worn out. As time passes, the battery life gradually becomes shorter. If the battery lasts about half the amount of time as when first purchased, it's time to purchase a new battery.

Q Why does the battery run out so quickly during normal use?

A It is due to the user environment or a large number of calls or weak signal.

Q Why is no number dialed when you recall a Contacts entry?

A Check that the number has been stored correctly by using the Contacts feature. Re-store them, if necessary.

Q Incoming calls do-not reach me.

A Is your phone switched on ( pressed for more than three seconds)? Are you accessing the right cellular network? Or, you may have set an incoming call barring option.

Q I cannot find the lock, PIN, or PUK code. What is my PIN?

A The default lock code is '0000'. If you forget or lose the lock code, contact your phone dealer. If you forget or lose a PIN or PUK code, or if you have not received such a code, contact 3 Customer Services.

Q What happens to the handset if it is dropped?

A The handset could power off or reset, but this does not necessarily imply any permanent damage.

Accessories

Charger

This adapter allows you to charge the battery. It supports standard Europe/Australia/U.K. and Hongkong (100-240 Volt 50/60Hz outlets).

It takes 3.5 hours to charge a completely discharged battery.



Europe



Australia



U.K and Hongkong

Headset

Connects to your phone, allowing hands-free operation. Includes earpiece, microphone, and integrated call answer/termination button.

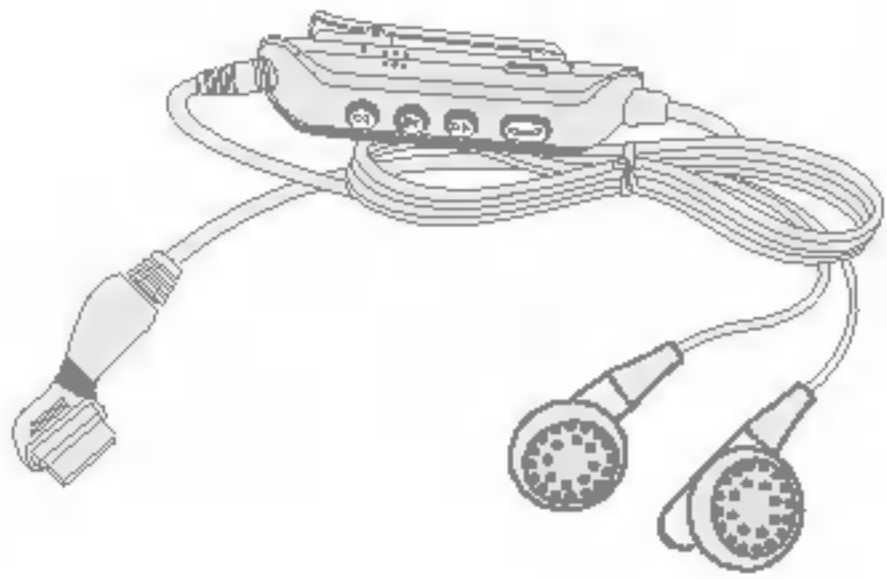

USB cable

Connects your phone to a PC.

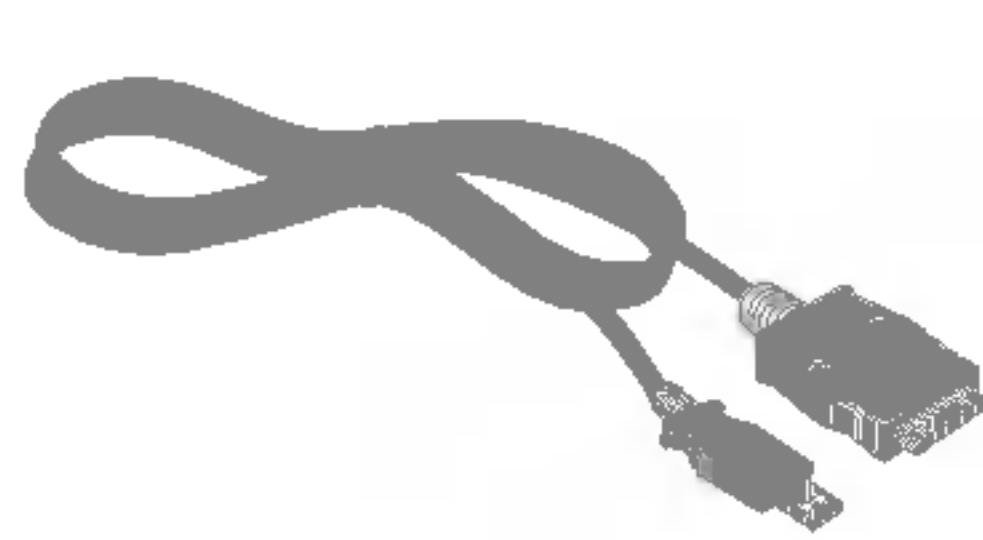

Hand strap



Battery



Glossary

2G

Second Generation wireless communication system. 2G system supports low quality voice and low-rate packet-data service. 2G refers to GSM in European countries, and CDMA in America.

3G

Third Generation wireless communication system. 3G means next generation wireless communication system developed based on the second generation wireless communication systems. 3G system supports real-time communication service and high-rate packet-data service. 3G refers to UMTS developed based on GSM in European countries,

Access point

Access point refers to a point through which users can connect to the network so that the users can use the network services.

AMR

Adaptive Multirate codec. A voice codec developed by ETSI for GSM. AMR supports 8 coding rates (from 4.75 to 12.2Kbps) so as to adaptively provide the quality of voice service in various radio channel conditions.

Download

Download means transmitting files from one computer system to another. Downloading usually means transmitting files from a big system to a small system.

IrDA (Infrared Data Association)

A standard defined by the IrDA consortium. It specifies a way to wirelessly transfer data via infrared radiation.

The IrDA specifications include standards for both the physical devices and the protocols they use to communicate with each other.

Java™

Programming language generating applications that can run on all hardware platforms, whether small, medium or large, without modification. It has been promoted for and geared heavily to the Web, both for public Web sites and Intranets. When a Java program runs from a Web page, it is called a Java applet. When it is run on a mobile phone or pager, it is called a MIDlet.

Line Identification Services (Caller ID)

Service allowing subscribers to view or block the telephone numbers of callers.

MIDI

Musical Instrument Digital Interface. A file format to save digitized musical instrumental data. The original meaning of MIDI, or Music Instrument Digital Interface is a protocol to exchange data between a computer and electric instruments.

MMS (Multimedia Message Service)

A message service for the handset environment, standardized by the WAP Forum and the 3rd Generation Partnership Program (3GPP). For phone users, MMS is

similar to Short Message Service (SMS)-it provides automatic, immediatedelivery of user-created content from phone to phone. The message addressing used is primarily phone numbers, thus the traffic goes from phone to phone. MMS also provides support for e-mail addressing, so that messages can also be sent by email. In addition to the text content of SMS, MMS messages can contain still images, voice or audio clips, and later also video clips and presentation information.

MP3

Moving Picture Experts Group Layer-3 Audio. A file format to provide high-quality audio whose quality is equal to that of CD. MP3 is a digital audio standard developed by MPEG, or Moving Picture Experts Group and is widely used for digital audio files.

MPEG4

Motion Picture Experts Group 4. A digital video standard developed by MPEG, or Moving Picture Experts Group. MPEG4 compresses video data so that a large video file can be transmitted, and saved more easily. MPEG4 is suitable especially for mobile environment.

Glossary

Multimedia

Multimedia means media that include various media data such as voice, character string, image, and video data. Currently, the meaning of multimedia includes services provided through multimedia.

Multiparty Calls

Ability to establish a conference call involving up to five additional parties.

Roaming

Use of your phone when you are outside your home area (when traveling for example).

SDN (Service Dial Number)

Telephone numbers supplied by your network provider and giving access to special services, such as voice mail, directory inquiries, customer support and emergency services.

SMTP

Simple Mail Transfer Protocol. A protocol to transfer e-mails between computers over the Internet. SMTP defines the format of control messages between computers, and interaction procedures between them to send e-mails.

Quick play

Quick play means a new type of service that enables users to listen to an audio or watch video without downloading complete audio or video file so that contents providers can provide audio or video data such as movie or news over the network in real-time on users' demand.

Sync

Sync means synchronizing PIM (Personal Information Management) data such as contact information, schedule, to-do, and memo with a PC or an external server.

UMTS

Universal Mobile Telephony System. UMTS refers to asynchronous 3G wireless technology of WCDMA that is developed based on GSM, the 2G wireless technology.

USB

Universal Serial Bus. A bus type interface that provides fast and flexible connection between devices and a computer.

USIM

Universal Subscriber Identity Module. An IC card used for UMTS the shape of which is the same as that of the SIM card of GSM. USIM is provided by network operator, and carries the authentication and service grade data for the network operator as well as user-specific data.

Video call

A communications service that enables users to talk watching each other over a 64Kbps data channel. Real-time video call service is a new type of service provided by WCDMA wireless communication system that is developed based on GSM+GPRS technology.

Voice mail

Computerised answering service that automatically answers your calls when you are not available, plays a greeting and records a message.

Index

A

Access Codes.....	43
Access points	67
Add new	73, 106
Alarm clock	123
AMR	144
Answer mode.....	138

B

Backlight.....	59
Barring Password.....	44
Battery	38
Battery Information.....	16
Battery cover.....	38
Battery level	40
Browser	72

C

Calculator.....	126
Calendar	114
Call barring.....	135
Call divert.....	134
Call diverting	40
Caller ID.....	145
Camera	103
Change codes	68
Charger.....	142
Charging the Battery.....	33
Confirmation tone.....	63

D

Dialled calls	133, 134
Display Information.....	40
Download.....	144

E

Entering Text	47
---------------------	----

F

Fixed dial numbers	136
Light.....	38
Flip tone	63
Font	59

H

Handset lock	68
Headset	143
Home	72

I

Inbox.....	84
Infrared Data Association.....	144
IrDA.....	144

J		
Java	145	
K		
Key tone	63	
Key tone volume	63	
L		
Language	69	
Line Identification Services	145	
M		
Mailbox.....	86	
Memo	118	
Memo Add.....	118	
Memo Delete	118	
Memory status.....	69, 104	
Message alert.....	62	
Message tone.....	63	
MIDI	145	
Missed calls.....	133	
MMS.....	145	
MP3	145	
MPEG4	145	
Multimedia	102, 146	
Multimedia Message Service.....	145	
N		
Network.....	67	
Network selection	67	
New messages	86	
O		
Open flip.....	47, 138	
Own number	107	
P		
PIN code.....	43	
PIN code request	68	
PIN2 code.....	43	
Press any key	138	
Press send key.....	138	
Profiles.....	62, 74	
PUK code	43	
PUK2 code.....	43	
Q		
Quick menu	122	
Quick play	146	
R		
Received calls.....	133	
Roaming	146	
Roaming service	40	
S		
Screen.....	58	
Screen theme	58	
SDN	146	
Search.....	106	
Secret memo	119	
Security.....	68, 74	
Security code	44, 69	
Service dial numbers.....	107	
Signal Strength	47	

Index

SMTP 146
Speed dials 106
Switch on sound 63
Switch off sound 63

T

T9 49
Templates 88
To do 117
To do Delete 117
To do Enquiry 117
Triangle key 37, 41

U

UMTS 147
Unit converter 127
USB 147
USB cable 143
USIM 147
USIM memory 70

V

Vibrate only 40, 62
Video calls 132, 135, 136
Video camera 102, 104
Video ringtone 62
Voice call 134, 135
Voice mail 147
Voice message 40
Voice recorder 104
Voice ringtone 62
Volume 129

W

World time 127

3G 144
3G network 40
2G network 40

Declaration of Conformity



Suppliers Details

Name

LG Electronics Inc

Address

LG Electronics Inc. LG Twin Towers 20,
Yeouido-dong, Yeongdeungpo-gu Seoul, Korea 150-721

Product Details

Product Name

E-GSM 900 / GSM 1800 / GSM 1900 / W-CDMA Terminal Equipment

Model Name

U8380

Trade Name

LG

CE 0889

Applicable Standards Details

R&TTE Directive 1999/5/EC

ETSI EN 301 489-01 V1.5.1, ETSI EN 301 489-07 V1.2.1
ETSI EN 301 489-17 V1.2.1, ETSI EN 301 489-24 V1.2.1
ETSI TS 151 010-1 V5.9.0 specified by ETSI EN 301 511 V9.0.2
ETSI TS 134 121 V5.5.0 specified by ETSI EN 301 908-2 V2.2.1
ETSI EN 301 908-1 V2.2.1, ETSI EN 300 328 V1.4.1
EN 50360:2001; EN 50361:2001
EN 60950 : 2001

Supplementary Information

The conformity to above standards is verified by RFI and Phoenix with Certificate No.(SC70885JD12)
It is stated in report (RFI/NOTA1/RP70885JD12).

I hereby declare under our sole responsibility that the product mentioned above to which this declaration relates complies with the above mentioned standards and Directives

Name

Jin Seog, Kim / Director

Issued Date

1.Mar.2005

LG Electronics Inc. Amsterdam Office
Veluwezoom 15, 1327 AE Almere, The Netherlands
Tel : +31 - 36- 547 - 8940, e-mail : seokim @ lge.com

Signature of representative



