



CAR CD/MP3/WMA Receiver

OWNER'S MANUAL

MODEL : LAC-M9600R

Please read this instruction booklet carefully and completely before connecting, operating or adjusting this product.



Safety note

	CAUTION RISK OF ELECTRIC SHOCK DO NOT OPEN	
<p>TO REDUCE THE RISK OF ELECTRIC SHOCK DO NOT SPLIT COVER(OR BACK) NO USER SERVICEABLE PARTS INSIDE. REFER SERVICING TO QUALIFIED SERVICE PERSONNEL.</p>		



The lightning flash with the arrowhead symbol, within an equilateral triangle is intended to alert the user about the presence of uninsulated dangerous voltage within the product's enclosure that may be of sufficient magnitude to constitute a risk of electric shock to persons.



The exclamation point within an equilateral triangle is intended to alert the user to the presence of important operating and maintenance (servicing) instructions in the literature accompanying the appliance.



Always operate the vehicle in a safe manner. Do not become distracted while driving, and always be fully aware of all driving conditions. Do not change settings, or any functions. Pull over in a safe and legal manner before attempting such operations.



Do not use for prolonged periods at extremely low or high temperature. (-10~60°C)



To reduce the risk of electric shock, do not remove the cover or back of this product. There are no user-serviceable parts inside. Refer servicing to qualified service personnel.



To reduce the risk of fire or electric shock, do not expose this product to dripping or splashing water, rain, or moisture.



The external temperature of the unit can be extremely high, only use the unit after proper installation in your vehicle.

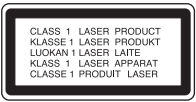

CAUTION : VISIBLE AND INVISIBLE LASER RADIATION WHEN OPEN AND INTERLOCKS DEFEATED.

CAUTION : This product uses a Laser System. To ensure proper use of this product, please read this owner's manual carefully and retain it for future reference. Should the unit require maintenance, contact an authorized service center. Performing controls, adjustments, or carrying out procedures other than those specified herein may result in hazardous radiation exposure. To prevent direct exposure to the laser beam, do not try to open the unit. Visible laser radiation when open. **DO NOT STARE INTO BEAM.**

Safety note



- A defective or soiled disc inserted into the unit can cause the sound to drop out during playback.
- Handle the disc by holding its inner and outer edges.
- Do not touch the surface of the unlabeled side of the disc.



Do not stick paper or tape, etc. on the surface.



Do not expose the disc to direct sunlight or excessive heat.



This unit cannot use 8cm disc (use 12cm discs only).

If an 8cm disc is inserted in error, press the EJECT button for a prolonged period with the front panel opened.



- Clean the disc before playback. Wipe the disc from the centre outward with a cleaning cloth.
- Never use solvents such as benzene or alcohol to clean the disc.

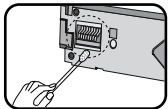

Periodically wipe the contacts on the back of the front panel with a cotton swab moistened with alcohol.



Bluetooth® wireless technology is a system which allows radio contact between electronic devices within a max. range of 10 meters. Connecting individual devices with Bluetooth® wireless technology does not incur any charges. A mobile phone with Bluetooth® wireless technology can be operated via the Cascade if the connection was made via Bluetooth® wireless technology.

CAUTION : Using Bluetooth

Carefully read this manual before using a bluetooth function.

- Close windows.
- Turn off the air conditioner/ heater.
- Stop the vehicle or drive at low speed.
- Make the call in a quiet location.
- There may be differences in call quality depending on phone type, road conditions weather, etc.
- Adjusting ECM (Echo Cancellation Mode) and MIC VOL, etc can give better call quality.
ECM (Echo Cancellation Mode) and, MIC VOL can be adjusted only when call is dropped.
- Using the phone while driving may cause unexpected accidents.
- The Bluetooth function may not operate properly with certain types of Bluetooth phones.



Safety note / Table of contents

Safety notes	2-4
Table of contents	4
Before use	5
Front panel	6
Remote control	7
Installation	8
Connection diagram	9
Connection	10
Basic operation	11-13
Setup operation	14-16
Bluetooth operation	17-21
Radio operation	22
RDS operation	23
CD/MP3/WMA operation	24-25
USB operation	26
USB(PPS) operation	27
Troubleshooting	28
Bluetooth phone compatibility list	29
Specifications	30-31



Disposal of your old appliance

1. When this crossed-out wheeled bin symbol is attached to a product, it means the product is covered by the European Directive 2002/96/EC.
2. All electrical and electronic products should be disposed of separately from the municipal waste stream via designated collection facilities appointed by the government or the local authorities.
3. The correct disposal of your old appliance will help prevent potential negative consequences for the environment and human health.
4. For more detailed information about disposal of your old appliance, please contact your local authority, waste disposal service or the shop where you purchased the product.



This product is manufactured to comply with the radio interference requirements of EEC DIRECTIVE 89/336/EEC, 93/68/EEC and 73/23/EEC.

Before use

Detaching the front panel

The front panel can be detached to prevent theft.

- 1 Press the  (RELEASE) to open the front panel.
- 2 Hold the left part of the front panel.
- 3 Pull the front panel.
- 4 Place the front panel in the supplied protective case.

Notes

- The front panel is a precision piece of equipment and can be damaged by shocks or jolts. For that reason, keep the front panel in its protective case while detached.
- Do not touch the connectors directly with your fingers or with any metal device.
- If the unit fails to operate properly, press the reset button using a ball point pen or a similar tool.

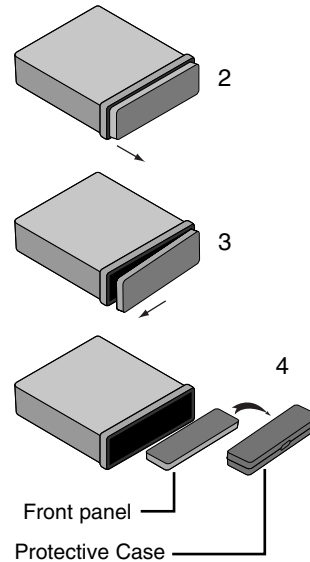
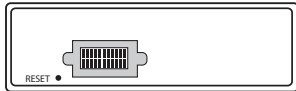

Attaching the front panel

The front panel can be detached to prevent theft.

- 1 Align the right side of the panel with the stopper.
- 2 Push the left side of the panel into the unit until it clicks.

Notes

- When detaching or attaching the front panel, do not press the display or control buttons.
- The control buttons may not work properly if the front panel is not attached properly. If this occurs, gently press the front panel.
- Do not leave the front panel in any area exposed to high temperatures or direct sunlight.
- Do not drop the front panel or it will cause strong impact.
- Do not allow such volatile agents as benzine, thinner, or insecticides to come into contact with the surface of the front panel.
- Do not try to disassemble the front panel.

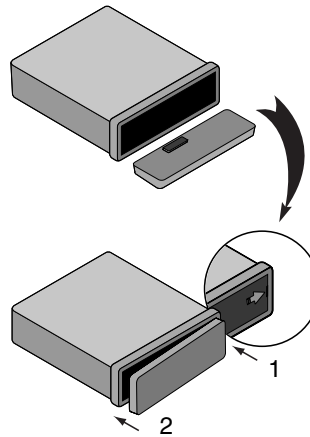

Front Panel

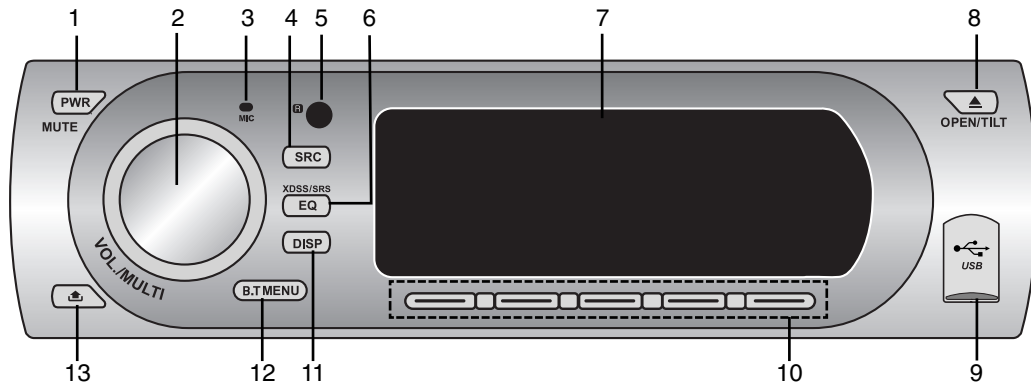

- | | |
|--|--|
| <p>1 POWER [PWR / MUTE]</p> <p>2 • VOLUME [VOL./MULTI]</p> <p>• SELECT</p> <p>• MENU (UP/DOWN/LEFT/RIGHT)</p> <p>• SKIP I◀◀ ▶▶I / SEARCH ◀◀ ▶▶</p> <p>• SEEK/ TUNE</p> <p>• MP3 TRACK +10/-10 MP3 WMA</p> <p>• FOLDER UP/DOWN MP3 WMA</p> <p>• Driver UP/DOWN MP3 WMA
(When connecting this unit to Multi reader.)</p> <p>3 MICROPHONE [MIC]</p> <p>4 SOURCE [SRC]</p> | <p>5 REMOTE SENSOR</p> <p>6 EQUALIZER [EQ / XDSS / SRS]</p> <p>7 DISPLAY WINDOW</p> <p>8 • EJECT ▲</p> <p>• [OPEN/TILT]</p> <p>9 USB SLOT</p> <p>10 *Multi-function key</p> <p>11 DISPLAY [DISP]</p> <p>12 BLUETOOTH MENU [B.T MENU]</p> <p>13 RELEASE ▲</p> |
|--|--|

*Multi-function Key

The Multi-function button controls various functions.

This unit is equipped with the Multi-function Key system which enables the operation of multiple functions with one button.

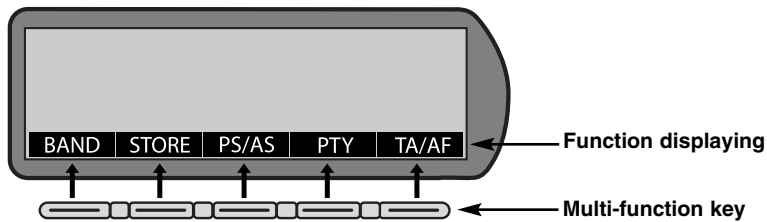

Remote control

- 1 POWER [PWR] / MUTE
- 2 SELECTION [MENU/SEL]
- 3 SOURCE [SRC]
- 4 PLAY / PAUSE
- 5 INTRO SCAN [SCAN]
- 6 SHUFFLE [SHF]
- 7
 - MP3 TRACK +10
 - FOLDER UP
 - MOVE UP
- 8
 - CD SKIP / SEARCH I
 - SEEK / TUNE I
 - MOVE LEFT
- 9
 - [BAND]
 - DRIVER [DRV]
 - ENTER
- 10 VOLUME UP / DOWN
- 11 NUMBER [#]
- 12 REPEAT [RPT]
- 13 NUMBER [0 -9]
- 14
 - CD SKIP / SEARCH
 - SEEK / TUNE
 - MOVE RIGHT
- 15 DISPLAY [DISP.]
- 16
 - MP3 TRACK -10
 - FOLDER DOWN
 - MOVE DOWN

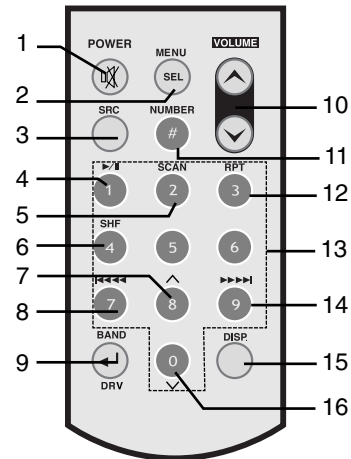

Battery installation

- 1 Remove the battery holder with a pencil or ball point pen.
- 2 Insert the batteries into the battery holder.
- 3 Insert the battery holder into its original position.

Notes

- Use only one CR2025 (3V) lithium battery.
- Remove the battery if the remote control is not used for a long period of time.
- Do not leave the product in a hot or humid place.
- Do not handle the battery using metallic tools.
- Do not store the battery together with metallic materials.
- In the event of battery leakage, wipe the remote control completely clean and install a new battery.

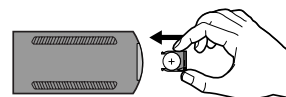
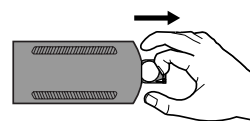
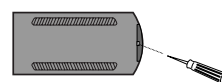

Installation

Basic Installation

Before installing, make sure that the ignition switch is set to OFF and remove the terminal of the car battery to avoid short-circuiting.

- 1 Remove the existing receiver unit.
- 2 Make the necessary connections.
- 3 Install the installation sleeve.
- 4 Install the unit into the installation sleeve.

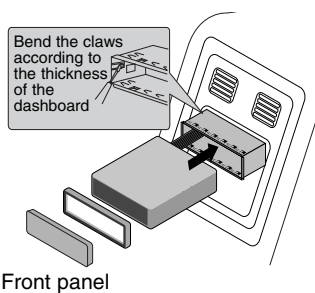

Removing the existing receiver unit.

If there is already an installation sleeve for the receiver unit in the dashboard, it must be removed.

- 1 Remove the rear support from the unit.
- 2 Remove the front panel and trim ring from the unit.
- 3 Insert the lever **A** into the hole on one side of the unit. Perform the same operation on the other side and pull the unit out from the mounting sleeve.

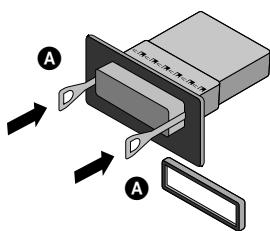

ISO-DIN Installation

- 1 Slide the unit into the ISO-DIN frame.
- 2 Install screws removed from the old unit.
- 3 Slide the unit and frame into the dash opening.
- 4 Install the dash panel or adapter plate.
- 5 Install the trim ring into unit.
- 6 Install the faceplate by fitting the right edge into position then pushing the left edge closed.

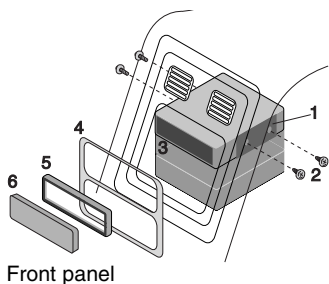

Connection diagram

Before connecting, make sure that the ignition switch is set to OFF, and remove the battery ⊖ terminal to avoid short circuits.

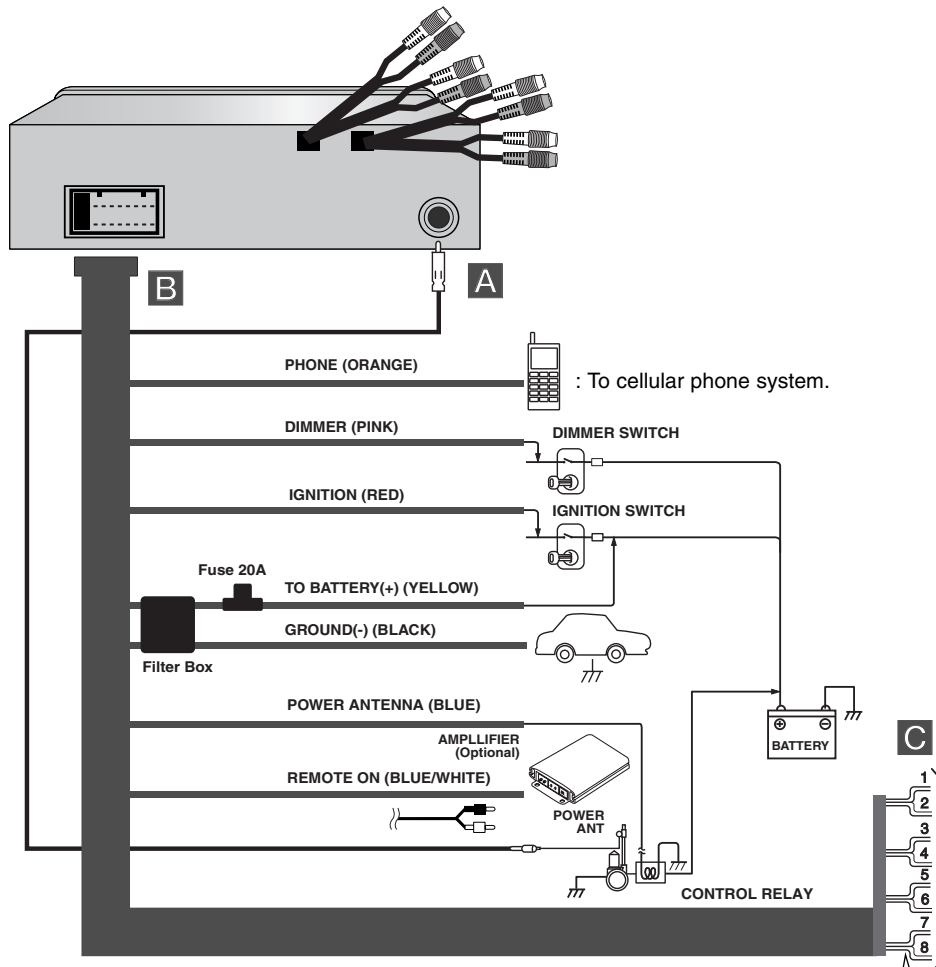

1. WHITE FL+
2. WHITE/BLACK STRIPE FL-
3. GRAY FR+
4. GRAY/ BLACK STRIPE FR-
5. GREEN RL+
6. GREEN/ BLACK STRIPE RL-
7. VIOLET RR+
8. VIOLET/ BLACK STRIPE RR-

Connection

A From antenna

B To the wiring of the vehicle colors of leads.

- **BLACK** : This lead is for the ground connection.
- **ORANGE** : This lead is for the phone line connection.
- **PINK** : This lead is for the dimmer line connection.
- **RED** : This lead is for connection to the power supply terminal when the ignition switch is set to ACC.
- **YELLOW** : This lead is for connection to the battery (back-up) terminal from which power is always supplied.
- **BLUE** : This lead is for the power antenna connection.
- **BLUE/WHITE** : This lead is for the remote amplifier on connection.

C Speaker Connections

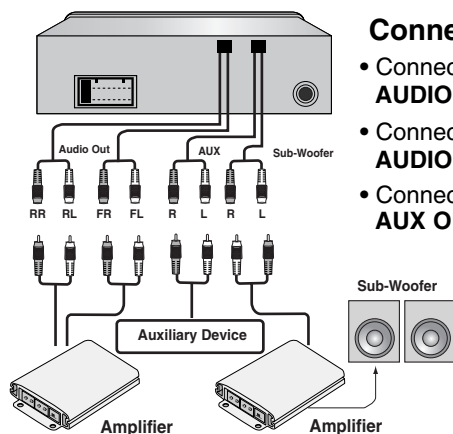
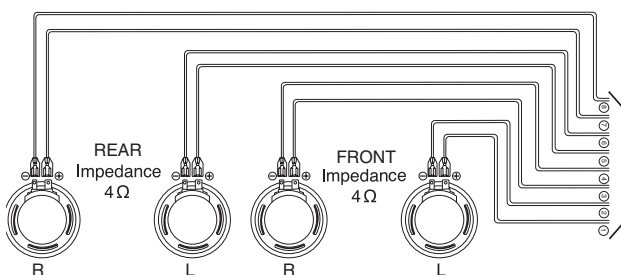

Connecting to Auxiliary Equipment (Optional)

- Connect the **AUDIO OUTPUT** connector of this unit to the **AUDIO INPUT** connector of the Amplifier.
- Connect the **SW (Sub-Woofer)** connector of this unit to the **AUDIO INPUT** connector of the Sub-Woofer.
- Connect the **AUX INPUT** connector of this unit to the **AUX OUTPUT** connector of the Auxiliary Equipment.

Basic operation



Turning the unit on

Press **PWR/MUTE** (**POWER/MUTE**  on the remote control) or any other button.

Note

When you insert a CD in the CD slot, the unit turns on.

Turning the unit off

Press and hold **PWR/MUTE**. (**POWER/MUTE**  on the remote control.)

Insert a disc

- 1 Press **▲/OPEN/TILT** to open the front panel.
- 2 The disc is drawn in and playback starts automatically.



Eject a disc

Press **▲/OPEN/TILT** to open the front panel. The disc automatically ejects from the loading slot.

When the disc is ejected by pressing **▲/OPEN/TILT** during playback, it will be loaded automatically after 10 seconds unless you remove the disc from the unit.

If a disc cannot be ejected, press **▲/OPEN/TILT** for a long time with the front panel opened.

Adjusting the volume

Rotate **VOL./MULTI** to adjust the sound level. 0 – 35
(Press **VOLUME**   on the remote control.)

Note

When you turn the unit off, the current volume level is automatically memorized. Whenever you turn the unit back on, it will operate at the memorised volume level.

Mute

- 1 Press **PWR/MUTE** (**POWER/MUTE**  on the remote control) to cut the sound.
- 2 To cancel, press again.

Changing the monitor angle

Press and hold **▲/OPEN/TILT** to adjust the front panel to an easily viewable angle.

- The angle of front panel can be adjusted up to 3 steps.
- The adjusted LCD panel angle will be memorised and the monitor panel will automatically return to this angle the next time the monitor panel is opened.

Selecting a source

Press **SRC** to select a source. Each press changes the modes as follows.
TUNER → CD → USB → AUX → BT MUSIC → TUNER...

Note

You cannot select a source if it is not ready.

Basic operation

Adjusting the sound level

- 1 Press **VOL./MULTI (MENU/SEL)** on the remote control repeatedly to select the desired mode. Each press changes the modes as follow.
USER EQ → BALANCE → FADER → SUB-W → VOL
- 2 Rotate **VOL./MULTI** (Press **VOLUME** ^ v on the remote control) to adjust the sound quality.
 - **USER EQ**
Adjust the 7-band graphic equalizer and store your own adjustments in the memory.
Push **VOL./MULTI** left or right to move to next stage.
(Press I◀◀ ◀◀/▶▶ ▶▶I on the remote control.)
 - **BALANCE**
Adjust the balance—speaker output balance between the left and right speakers.
L(Left Speaker)10 – R(Right Speaker)10
 - **FADER**
Adjust fader—speaker output balance between the front and rear speakers.
F(Front Speaker)10 – R(Rear Speaker)10
 - **SUB-W**
Adjust the Sub-woofer output level. 0 – 35
 - **VOL**
Adjust the sound level. 0 – 35

Note

Normally the function works as a sound level control. You can not select USER EQ to adjust the EQ level when it is in EQ (POP, CLASSIC, ROCK JAZZ, VOCAL, SALSA, SAMBA) mode.

Using the EQ (Equalizer)

The equalizer lets you adjust the equalization to match the acoustic characteristics of the car's interior as desired.

Press **EQ/XDSS/SRS** repeatedly. Each press changes the modes as follow.

POP → CLASSIC → ROCK → JAZZ → VOCAL → SALSA → SAMBA → USER1 → USER2 → EQ OFF (FLAT)

- **POP** : Optimised for R&B, Soul and Country music.
- **CLASSIC** : Optimised for orchestral music.
- **ROCK** : Optimised for Hard Rock and Heavy Metal music.
- **JAZZ** : Sweet sound with soft feeling.
- **VOCAL** : Powerful realism with strong sound quality.
- **SALSA** : Reproduces salsa music acoustics.
- **SAMBA** : Reproduces samba music acoustics.
- **USER1** : Use the menu to set the sound level you want.
- **USER2** : Use the menu to set the sound level you want.
- **EQ OFF (FLAT)** : Cancels equalizer play.

You can adjust each sound level to your preference. Once you select a USER mode and then make an adjustment, it is automatically stored for the currently selected USER mode.
See "Adjusting the sound level".

Basic operation

XDSS/XDSS+ (Extreme Dynamic Sound System)

Press and hold **EQ/XDSS/SRS** to select XDSS or XDSS+
XDSS → XDSS+ → SRS (Focus → TruBass → 3D-Stereo → WOW) → By pass
XDSS/XDSS+ : Improve the treble, bass sound.

SRS (Sound Retrieval System)

- 1 Press and hold **EQ/XDSS/SRS** to select SRS.
- 2 Press **EQ/XDSS/SRS** repeatedly to select sub SRS.
 - Focus : Electronically repositions the audio image.
 - TruBass : Psychoacoustic bass enhancement.
 - 3D-Stereo : Positions audio effects real time in 3D space.
 - WOW : Extremely wide stereo imaging and improved low frequency bass.

Notes

- **SRS WOW** is a trademark of the SRS Labs, Inc.
- WOW technology is incorporated under license of the SRS Labs, Inc.
- You can not use the EQ function while using the SRS function.

Selecting the display mode

Each time you press and hold **DISP**, the display mode changes as follow.
Standard mode → Movie mode → Level meter mode

Standard mode

Displays images and pre-stored moving pictures with various information.



Movie mode

Displays pre-stored moving pictures without information.



Level meter mode

Displays audio level meters.



Setup operation

Selecting Setup Menu

- 1 Press and hold **VOL./MULTI** to enter Setup menu. (**MENU/SEL** on remote control.)
The menu screen appears.
AUDIO ↔ DISP (Display) ↔ HF (Hands-Free) ↔ RDS



- 2 Push **VOL./MULTI** left or right to scroll through the main menus.
(Press **I◀◀◀/▶▶▶I** on the remote control.)
- 3 Select the desired menu and press **VOL./MULTI** to view its sub-menu.
- 4 Push **VOL./MULTI** up or down to move the sub-menu.
(Press **▲▼** on the remote control.)
- 5 Select the desired function from the sub-menu and press **VOL./MULTI** to display that functions details. (Press **BAND/DRV** on remote control.)
- 6 Push **VOL./MULTI** left or right to select the settings.
(Press **I◀◀◀/▶▶▶I** on the remote control.)
- 7 Once the desired setting is chosen, press **VOL./MULTI**.
(Press **BAND/DRV** on remote control.)
- 8 Press and hold **VOL./MULTI** again to exit the current menu.
(Press and hold **MENU/SEL** on the remote control.)
Or press the **EXIT**.

● AUDIO

Key Beep

Set the beep sound every time a button is pressed.

- 2ND : The beep is only generated when a key is pressed for a longer period of time (1 sec).
- ALL : The beep is generated when any key is pressed.

SRS (Sound Retrieval System) Focus

Set the SRS focus quality.

- Low : You can decrease the SRS focus level.
- High : You can increase the SRS focus level.

HPF (High Pass Filter)

Outputs all frequencies higher than selected according to your preference.

Setting range : Off / 90Hz / 135Hz / 180Hz / 225Hz

SW LPF (Sub Woofer Low Pass Filter)

You can adjust the cut-off frequency and the output level of subwoofer.

Setting range : Off / 80Hz / 120Hz / 160Hz

Setup operation

AUX In

It is possible to use auxiliary equipment with this unit. Activate the auxiliary setting when using auxiliary equipment connected to this unit.

- Enable : When using a auxiliary equipment.
- Disable : When not using a auxiliary equipment.

AUX In Att. (Auxiliary In Attenuate)

You can adjust the volume level of each source to prevent radical changes in volume when switching between sources.

Setting range : 0 dB / +6 dB

If the input level of the connected component is not high enough, increase the input level properly. Without adjusting the line input level, you may be surprised at a loud sound when you change the source from the external component to another source.

Out Power

Set the maximum volume level of this unit.

Setting range : 40W / 60W

If the output level from the unit is too high the unit will not be output normally.

Adjust the output level to 40W when external amplifier is connected.

• **DISP**

Background

You can select one of 7 modes. It displays the change of sound output during play.

Ani1 / Ani2 / Ani1&2 / 1 Picture / ALL Pictures / Equalizer1 / Equalizer2

- Ani1 / Ani2 / Ani1&2 : Pre-stored animation is activated.
- 1 Picture : One of your edited still images stored in the memory is activated.
- ALL Pictures : All stored still images are activated and shown in sequence.
- Equalizer1 / Equalizer2 : Pre-stored level meter is activated.

PPS (Personal Picture Skin) Select

You can select one of your edited still images stored in the memory.

PPS (Personal Picture Skin) Delete

You can delete unnecessary stored images.

- Please see page 27 for details.

PPS (Personal Picture Skin) Upload

You can store maximum 18 images from the USB device connected.

- Please see page 27 for details.

Dimmer

To prevent the display from being too bright at night, the display is automatically dimmed when the car's headlights are turned on. You can turn the dimmer on or off.

- Auto : Activates Auto Dimmer.
- Off : Cancels Auto Dimmer.

Brightness

You can adjust the display for easier viewing when lighting conditions change.

Dark : ← 1 / 2 / 3 / 4 / 5 → : Light

Setup operation

- **HF (Hands-Free)**

- **MIC Vol (Microphone Volume)**

- You can set the microphone volume.

- Low : ← 1 / 2 / 3 / 4 / 5 → : High

- **E.C.M (Echo Cancellation Mode)**

- This decreases any echo phenomena of voice coming from the Bluetooth phone of the other party when working Bluetooth. Set the mode(1-3) to the appropriate condition when talking over the phone.

- Mode1 / Mode2 / Mode3

- **Last Call**

- Your unit keeps records of your recently received and dialed calls.

- To make a call from the last call, press **VOL./MULTI** to place a call to the entered number. 1 Time / 2 Times

- It may be that sending is done by pressing **VOL./MULTI** twice depending on type of bluetooth phone.

- Please see page 19 for details.

- **RDS**

- **REG (Region)**

- ON : Network-Tracking is activated.

- The unit switches to another station, within the same network, broadcasting the same programme when the receiving signals from the current station become weak.

- OFF : Network-Tracking is activated.

- The unit switches to another station, within the same network when the receiving signals from the current station become weak.(In this mode, the programme may differ from the one currently received.)

- **TA (Traffic Announcement Identification)**

- Seek : When the newly tuned station does not receive TP information for 5 seconds, the receiver retunes to the next station which has the same PI as the last station, but has the TP information.

- Alarm : When a newly tuned station has no TP information for 5 seconds, a double beep sound is output.

- **DPI (Programme Identification)**

- Sound : If the sound of a station with different PI is heard intermittently, the receiver mutes the sound after 1 second.

- Mute : If the situation described above is repeated, the receiver instantly mutes the sound.

Bluetooth operation

Using a Bluetooth wireless connection

Your unit supports Bluetooth wireless connections. You can set up a wireless link with a Bluetooth phone.

Starting Bluetooth on your phone

Your phone's Bluetooth feature may be set to off by default. To use your car Bluetooth feature, Bluetooth must be turned on in your phone.

Refer to your phone's user guide.



Pairing your unit and Bluetooth phone

Pairing links your unit and Bluetooth phone, and is required only once for the initial setup. Before you start the pairing procedure, make sure the Bluetooth feature is turned on in your Bluetooth phone. Refer to your Bluetooth phone's user guide.

- 1 Press and hold **B.T MENU** to display the HF menu.

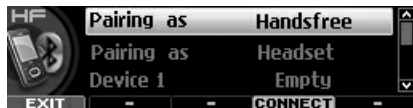

- 2 Push **VOL./MULTI** up or down to select Handsfree or Headset.
(Press **▲ ▼** on the remote control.)
If connecting through a Bluetooth phone, the handsfree connection or headset connection may operate depending on the type of phone.
With connection via Bluetooth technology, HFP (Hands Free Profile) is prioritised over HSP (Head Set Profile).
- 3 Press **VOL./MULTI** to connect a Bluetooth phone to this unit.
(Press **BAND/DRV** on remote control.)
The "READY FOR PAIRING" pop-up is displayed.
LG CAR AUDIO PIN CODE : 1234
- 4 You can set up a wireless link with Bluetooth phone.
Refer to your phone's user guide.
- 5 The unit may request permission to bond with your phone.
- 6 The Bluetooth phone displays the device name, select the device.
- 7 The Bluetooth phone displays the PIN code enter screen, enter the PIN code.
- 8 If the connection is successful, the Bluetooth phone is registered (Device 1-4).
- 9 Press **EXIT** in the current screen to exit previous screen.

Notes

- Your unit keeps lists of the pairing you recently connected. A maximum of 4 pairing devices can be saved.
- The Bluetooth phone which has a previous record showing that it has successfully connected will automatically start the connecting process when starting the car.
- Unlike the handsfree functionality, Headset connection will allow only two functions "answering calls" and "making a call from the last call".
Also the caller's number is not displayed when answering calls.

Bluetooth operation

Connecting a Bluetooth phone

After being registered, it is necessary to connect your Bluetooth phone from this unit.

- 1 Push **VOL./MULTI** up or down to select the device you want.
(Press **Λ V** on the remote control.)
You will see a list containing all the previously connected devices.

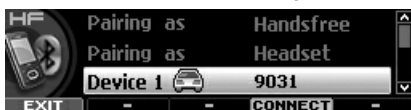

- 2 Press **VOL./MULTI** to connect a Bluetooth phone to this unit.
(Press the **BAND/DRV** on the remote control.)
While connecting, the "CONNECTING" pop-up is displayed.
If you want to cancel, select the "CANCEL".

Disconnecting a Bluetooth phone

This operation is possible when your Bluetooth phone has already been connected to this unit.

- 1 Press **DISCON** to disconnect a Bluetooth phone from this unit.



- 2 Press **VOL./MULTI**. (Press **BAND/DRV** on remote control.)
The "DISCONNECT" pop-up is displayed.
- 3 Push **VOL./MULTI** left or right to select "OK" or "CANCEL".
(Press **I◀◀ ◀/▶▶ ▶I** on remote control.)
If you want to disconnect, select the "OK".
If you want to cancel, select the "CANCEL".
- 4 Press **VOL./MULTI** to confirm.

Bluetooth operation



Answering calls

When you receive a call, your phone rings and displays an incoming call message.

1. The "CALL FROM" pop-up is displayed.
2. Push **VOL./MULTI** left or right to select "ACCEPT" or "REJECT".
(Press **I◀◀/▶▶I** on the remote control.)
If you want to receive a call, select the "ACCEPT".
If you want to reject a call, select the "REJECT".
3. Press **VOL./MULTI**.
4. The "TALKING" pop-up is displayed.
Press "HANG UP" to end the call.
Press "PRIVATE" to activate your phone's speaker.
(You can mute the sound from the car's speakers.)

✦ Notes

- If the Call-ID service is available, the caller's phone number is displayed.
- If "REJECT" function is unusable, then the phone connected to the device does not support the reject call function.
- If the private mode is selected on bluetooth phone, press **B.T MENU** to return to the call to hands-free mode. (This feature is only available on phones with a Hands-free profile.)
Or press and hold **B.T MENU** to return to the call to hands-free mode. (This feature is only available on phones with a Headset profile.)

Making a call from the latest call : Last Call

Your unit keeps records of your recently received and dialed calls.

1. Press **B.T MENU** to display the HF menu.
2. Push **VOL./MULTI** up or down to select the Dial : Last Call.
(Press **Λ V** on the remote control.)
3. Press **VOL./MULTI** to place a call to entered phone number.
(Press **BAND/DRV** on the remote control.)
The "DIALLING LAST CALL" pop-up is displayed.
If you select "CANCEL", the call is cancelled.

Making a call from an incoming call

Your unit keeps a record of your recently received calls.

1. Press **B.T MENU** to display the HF menu.
2. Push **VOL./MULTI** up or down to select the Dial : incoming call number.
(Press the **Λ V** on the remote control.)
3. Press **VOL./MULTI** to place a call to the entered phone number.
(Press **BAND/DRV** on the remote control.)
The "DIALING" pop-up is displayed.
If you select "CANCEL", the call is cancelled.

✦ Notes

- When you want to make an international call, press and hold **B.T MENU** to add "+".
- Press **EXIT** in the current screen to exit previous screen.

Bluetooth operation

Storing a call number : Store

You can easily store up to 6 internal entries for later recall at the touch of a button.

- 1 Push **VOL./MULTI** up or down to select the Store : incoming call number.
(Press **Λ V** on the remote control.)
- 2 Press **VOL./MULTI**. (Press **BAND/DRV** on the remote control.)
Display the phone number you want to save in the memory.
When you want to save an international call, press and hold **B.T MENU** to add "+".
To cancel, press and hold again.
- 3 Push **VOL./MULTI** left or right to select one of preset number 1–6.
(Press **I◀◀◀/▶▶▶I** on the remote control.)
- 4 Press **VOL./MULTI**. (Press **BAND/DRV** on the remote control.)
The selected number has been stored in the memory.
- 5 Repeat steps 1 and 4 to save other calls.
Next time, you press the same preset number, the number is recalled from the memory.

Making a call from the preset list

It is possible to make a call from the preset phone number list.

- 1 Press **PRESET**.
- 2 Push **VOL./MULTI** up or down to select the preset phone number.
(Press **Λ V** on the remote control.)
- 3 Press **VOL./MULTI** to place a call to entered phone number.
(Press **BAND/DRV** on the remote control.)
The "DIALING" pop-up is displayed.
If you want to cancel the call, select the "CANCEL".
- 4 The "TALKING" pop-up is displayed.
Press "HANG UP" to end the call.
Press "PRIVATE" to activate your phone's speaker.
(You can mute the sound from the car's speakers.)

Pairing your unit and Bluetooth device (MP3 Player, MP3 Phone...)

When you activate your Bluetooth device's linked unit, you can listen to MP3 with wireless connections.

The method of use for a Bluetooth device is the same as when using a Bluetooth phone.

- Please see page 17 for details.

Playing MP3 files

When you turn Bluetooth on, your Bluetooth device displays "Bluetooth" on the home screen.

The Bluetooth remains on until you turn the device off.

Press the **SRC** repeatedly to select Bluetooth.

The indicator lights up in the following order.

TUNER → CD → AUX → BT-MUSIC → TUNER...

To play an MP3 file stored on your Bluetooth device, refer to your Bluetooth device's user guide.

Note

This function, cannot be used a bluetooth device which does not have MP3 function.

Bluetooth operation



Bluetooth Profiles

In order to use Bluetooth technology, devices must be able to interpret certain profiles. This unit is compatible with following profiles.

GAP (Generic Access Profile)

HSP (Hands Set Profile)

HFP (Hands Free Profile)

GAVDP (Generic Audio/Video Distribution Profile)

A2DP (Advanced Audio Distribution Profile)

AVDTP (Audio/Video Distribution Transport Profile)

AVRCP (Audio/Video Distribution Remote Control Profile)

GAP

GAP is short for Generic Access Profile. This is a basic profile of Bluetooth wireless technology.

HFP

HFP is short for Hands-Free Profile. This profile is used for hands-free phoning with the devices featuring Bluetooth wireless technology.

HSP

HSP is short for Head Set Profile. This profile is used for connecting a headset and for communicating terminal wireless technology.

GAVDP

This profile uses an Initiator (INT), a device (such as a portable player) that initiates a signalling procedure to send a request to an Acceptor (ACP), - such as headphones etc. Although this profile specifies signalling transaction procedures between two devices to set up, terminate, and reconfigure streaming channels, using GAVDP alone, it is required to use GAVDP in combination with profiles that depend on this profile - the AVRCP and the VDP.

A2DP

Mobile phones and devices with A2DP high quality stereo bluetooth profile.

This profile is based on the GAVDP, and allows advanced audio to be transmitted (audio streaming) from a Source (SRK) - such as a CD player, to a Sink (SNK), such as headphones.

AVRCP

Based on the GAP Profile, this uses a Controller (CT) - PDA, computer mobile phone etc., which sends a command to a Target (TG) - TV, discman, headphone etc. The command can be to Play, record, colour control, volume control etc., depending on the nature of the devices involved and the scenario. The commands are transported by a new additional protocol, called the Audio/Video Control Transport Protocol (AVCTP). Some scenarios defined are Remote Control from a Separate Controller, Remote Control and Audio Stream Between Two Devices, and Remote Controller with LCD.

Radio operation

Listening to radio stations

- 1 Press **SRC** to select the radio.
- 2 Press **BAND** repeatedly to select a band.
Each press changes the modes as follows. FM1 → FM2 → FM3 → MW(AM)
- 3 **Auto Search** : Push **VOL./MULTI** left or right. (Press **◀◀ ◀▶▶ ▶▶▶** on the remote control.) When a station is received, searching stops.
Manual Search : Push and hold **VOL./MULTI** left or right until "MANUAL" appears, and then push it repeatedly.
(Press and hold **◀◀ ◀▶▶ ▶▶▶** on the remote control, and then press it repeatedly.)
The frequencies move up or down step by step.

Storing broadcast frequencies

You can easily store up to 6 stations for a each band.

- 1 Press **BAND** to select desired band you want to store.
- 2 Press **STORE** to activate the preset mode.
- 3 Push **VOL./MULTI** up or down to select any one of the preset numbers (1–6).
- 4 Press **STORE** to store the channel.
- 5 Repeat step 1 and 4 to preset other stations.

✦ Notes

- Up to 18 FM stations, 6 for each of three FM bands and 6 MW(AM) stations can be stored in the memory.
- When a station is stored on the preset numbers on which another station of the same band has already been preset, the previously preset station is automatically erased.

Auto search memory

- 1 Press and hold **PS/AS** until "AUTO SEARCH MEMORY" appears.
The six strongest broadcast frequencies will be stored under preset numbers (1–6) in the order of their signal strength.
- 2 To cancel, press **PS/AS**.

To scan the preset stations

Press **PS/AS**. Each preset station appears.
To cancel, press **PS/AS**.

To tune in the preset stations

- 1 Press **BAND** to select the desired band.
- 2 Push **VOL./MULTI** up or down to select any one of preset numbers (1–6).

RDS operation



RDS Display options

In normal RDS operation the display will indicate the station name. Pressing **DISP** enables you to cycle through the various data types in the following sequence:

CT → FREQUENCY → PTY → RT → PS

- **CT** (Time controlled by the channel)
- **PTY** (Programme type recognition)
- **RT** (Radio text recognition)
- **PS** (Programme Service name)
- **PI** (Programme Identification)
- **AF** (Alternative Frequencies for the actual programme)
- **TP** (Traffic programme Identification)
- **TA** (Traffic Announcement Identification)

PTY (Programme Type) function

To select a certain programme type from the reception band, the following procedure may be used.

- 1 Press **PTY** to select a programme type.
- 2 Press one of the program types.
There are four programme types.
SPEECH1 – SPEECH2 – MUSIC1 – MUSIC2
- 3 Push **VOL./MULTI** up, down, left or right to select any one of programme type name.
- 4 Press **VOL./MULTI**.
The “SEARCHING” pop-up is displayed.
CANCEL : Cancels the function.

Note

RDS is only available for FM reception.

RDS TA (Traffic Announcement) function

TA reception allows the unit to switch temporarily to a Traffic Announcement from the current source (another FM station, CD, or other connected components).

To switch the TA (Traffic Announcement) function on or off, press **TA/AF**.

RDS AF (Alternative Frequency) function

When the reception quality drops, the tuner automatically changes to another station in the network, which is broadcasting better reception quality, using the PI and AF codes.
This means : wherever you drive, you can continue to listen to the same programme without any interruption.

To switch the AF (Alternative Frequencies) function on or off, press and hold **TA/AF**.

CD/MP3/WMA operation

Playing an Audio CD and MP3/WMA Disc

The unit can play MP3/WMA formatted recordings on CD-ROM, CD-R or CD-RW discs. Before playing MP3/WMA recordings, read the notes on MP3/WMA Recordings on page 30. If you change the source, CD play also stops (without ejecting the CD). Next time you select "CD" as a source, CD play starts from where playback was stopped previously.

- To directly play a file, press **NUMBER (#)** on the remote control and then press the track number **0-9**.

Pause **CD** **MP3** **WMA**

- 1 Press **PAUSE** during playback.
- 2 To return to playback, press **PLAY**.

Moving to another track **CD** **MP3** **WMA**

- Push **VOL./MULTI** left or right during playback to select the next track or to return the beginning of the current track. (Press **I◀◀◀/▶▶▶I** on the remote control.)
- Push **VOL./MULTI** left to select the previous track. (Press **I◀◀◀** on the remote control.) (If playing time is less than 4 seconds, this function will not operate.)

Search **CD** **MP3** **WMA**

Push and hold **VOL./MULTI** left or right during playback and then release at the desired point. (Press and hold **I◀◀◀◀/▶▶▶▶I** on the remote control.)

Repeat **CD** **MP3** **WMA**

- 1 Press **RPT** during playback.
The **1** appears in the display window. **CD** **MP3** **WMA**
(The current selected music on the disc is played repeatedly.)
Press and hold **RPT** for about 1 second during playback.
The **F** appears in the display window. **MP3** **WMA**
(The current selected folder on the disc is played repeatedly.)
- 2 Press **RPT** again.
(The repeat mode is cancelled.)

Intro scan **CD** **MP3** **WMA**

- 1 Press **SCAN**.
The **F** appears in the display window. **MP3** **WMA**
(The first 10 seconds of each file in the currently selected folder on the disc are played.)
The **A** appears in the display window. **CD**
(The first 10 seconds of each file on the disc are played.)
Press and hold **SCAN** for about 1 second during playback.
The **A** appears in the display window. **MP3** **WMA**
(The first 10 seconds of each file on the disc are played.)
- 2 Press **SCAN** again.
(The intro scan is cancelled.)

CD/MP3/WMA operation

Random **CD** **MP3** **WMA**

- 1 Press **SHF** during playback.
The **F** appears in the display window. **MP3** **WMA**
(The current selected folder on the disc is played randomly.)
The **A** appears in the display window. **CD**
(All of the music on the disc is played randomly.)
Press and hold **SHF** for about 1 second during playback.
The **A** appears in the display window. **MP3** **WMA**
(All of the music on the disc is played randomly.)
- 2 Press **SHF** again.
(The random playback is cancelled.)

Note

During random playback, if you push **VOL./MULTI** left or press **I** on the remote control., you will not return to the previous track.

CD TEXT / ID3 TAG **CD** **MP3** **WMA**

When playing a disc containing information, you can see the CD TEXT/ID3 TAG information. In CD TEXT, information about the disc (disc title, performer and track title) is recorded. In a ID3 TAG, information about the file (album title, Performer name, song title, recording year, music genre and a brief comment) is recorded. In a WMA Content, information about the file (album title, Performer name) is recorded. If there is no information, "NO TEXT" will be shown in the display window. Press **DISP** repeatedly during MP3/WMA/CD TEXT file playback.

MP3/WMA TRACK -10/+10 **MP3** **WMA** (If there is no folder or one folder.)

During playback, push **VOL./MULTI** (press **V** on remote control) down to skip to the previous 10 track, and push **VOL./MULTI** (press **^** on remote control) up to skip to the next 10 track.

MP3/WMA FOLDER UP/DOWN **MP3** **WMA** (If there are more than two folders.)

During playback, push **VOL./MULTI** (press **V** on remote control) down to go to the previous folder, and push **VOL./MULTI** (press **^** on remote control) up to go to the next folder.

Note

The time display appearing on the display when playing a VBR file may vary and there may be some difference from the actual time (both progress time and VBR are displayed at the same time when playing a file).

USB operation

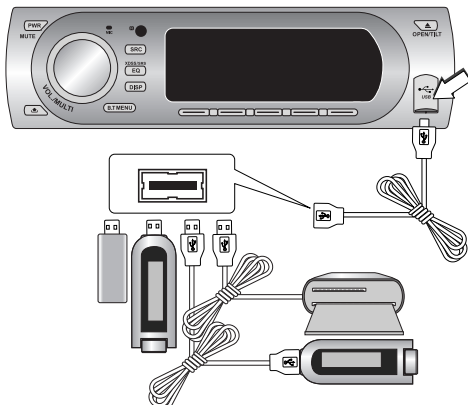

If the plug length of the USB device is under 10mm, the USB device may not be correctly inserted or a connection failure may occur.

Playing a USB device

- 1 Connect one end to the USB port on your USB device and then plug the other end into your unit's USB port.
- 2 After "USB CHECKING" appears, playback starts automatically.

Note

The method of files recorded in a USB memory device is the same as when using a DISC.

Moving to another driver

When connecting this unit to Multi reader, push **VOL./MULTI** up and hold to go to the next driver. (Press **BAND/DRV** on the remote control.)

Each time you press the button, the driver modes changes.

Notes

- Do not remove an MP3 player or memory card while playing via a USB device.
- The maximum number of available files is 999 EA.
- The maximum number of available folders is 255 EA.
- Be sure to save the file in the memory card after formatting.
- There is no support for hard type external cases.
- This unit supports FAT format (512 byte/sector).
- USB Hub is not supported. When connecting this unit to a USB Hub, "USB CHECKING/NO SERVICE" will be shown in the display window.
- Some memory sticks or cards may not be recognised depending on the type of memory card.
- There is no support for a USB device (Card reader, USB memory stick, MP3 player) which requires installation.
- If the connected device is not supported, "USB ERR1" or "USB ERR2" will appear on the display window.
- Do not support USB devices that adopted the 2KB transfer protocol.
- Do not supply excess of supplying current. (The maximum supplying current is around 500 mA)
- Do not support USB devices that adopted OTG technology.

USB (PPS) operation

Downloading still image files

Before starting the following procedure, prepare a USB device including still image.

- 1 Press and hold **VOL./MULTI** to enter Setup menu.
(Press **MENU/SEL** on the remote control.)
- 2 Select the DISP menu.
- 3 Select the PPS Upload.
- 4 Press **VOL./MULTI** to confirm. (Press **BAND/DRV** on the remote control.)
- 5 Push **VOL./MULTI** left or right to select the still image file you want.
(Press **I◀◀◀/▶▶▶I** on the remote control.)
- 6 Press **VOL./MULTI** to confirm. (Press **BAND/DRV** on the remote control.)
Installation is progressing.

✦ Notes

- With the Image Converter (LG Personal Picture Skin V1.0) CD included, you can create your own images. Run LG Personal Picture Skin and press the Help menu.
- Still images should have the following extension code in the file name.
BMP : for small size still images.

Deleting the stored still image

- 1 Select the PPS Delete.
- 2 Press **VOL./MULTI** to confirm. (Press **BAND/DRV** on the remote control.)
- 3 Push **VOL./MULTI** left or right to select the still image file you want.
(Press **I◀◀◀/▶▶▶I** on the remote control.)
- 4 Press **VOL./MULTI** to confirm. (Press **BAND/DRV** on the remote control.)
The "DELETE" pop-up is displayed.
OK : Activates the function.
CANCEL : Cancels the function.

✦ Notes

- Do not download a file while driving.
- Do not turn off the ignition key of the car while downloading or deleting a file.
- Do not detach the front panel while downloading or deleting a file.
- Do not remove a USB device while downloading or deleting a file.
- In that case, light image can reduce LCD background life.

Troubleshooting

Symptom	Cause	Correction
Power doesn't turn on. The unit doesn't operate.	<ul style="list-style-type: none"> Leads and connectors are not properly connected. The fuse has blown. Noise and other factors are causing the built-in microprocessor to operate incorrectly. 	<ul style="list-style-type: none"> Confirm once more that all connections are correct. Rectify the problem which caused the fuse to blow, and then replace it. Be very sure to install the correct fuse of the same rating. Turn the unit off and then on.
Playback is not possible.	<ul style="list-style-type: none"> The disc is dirty. The loaded disc is the type that this unit cannot play. 	<ul style="list-style-type: none"> Clean disc. Check the type of the disc.
No sound is heard. The volume level doesn't rise.	<ul style="list-style-type: none"> Cables are not connected correctly. 	<ul style="list-style-type: none"> Connect the cables correctly.
There's no sound.	<ul style="list-style-type: none"> The volume level is low. 	<ul style="list-style-type: none"> Adjust the volume.
There's audio skipping.	<ul style="list-style-type: none"> This unit is not firmly secured. 	<ul style="list-style-type: none"> Secure the unit firmly.
The unit does not operate correctly even when the appropriate remote control buttons are pressed.	<ul style="list-style-type: none"> Battery power is low. Some operations with certain discs are prohibited. 	<ul style="list-style-type: none"> Load new battery. Check with another disc.

Bluetooth phone compatibility list

Bluetooth Phone list and manufacturing company applicable

Company	List	Company	List
Nokia	8910i	LG	LG KG800
Nokia	6021	LG	LG KU730
Nokia	3230	LG	U8210
Nokia	3650	LG	KP-4000
Nokia	6210i	Motorola	E1000
Nokia	6310i	Motorola	V600
Nokia	6230	Motorola	V3 razor
Nokia	6230i	Motorola	L6
Nokia	6260	Motorola	E1
Nokia	6600	Motorola	A1000
Nokia	9500	Sony-Ericsson	T68i
Nokia	6630	Sony-Ericsson	T610
Nokia	6680	Sony-Ericsson	K600i
Nokia	6681	Sony-Ericsson	K700i
Nokia	N70-1	Sony-Ericsson	S700i
Nokia	8800	Sony-Ericsson	V600
Nokia	8801	Sony-Ericsson	K750i
Samsung	SGH-D500	Sony-Ericsson	W550i
Samsung	SGH-D508	Sony-Ericsson	W800i
Samsung	SGH-D600	Sony-Ericsson	P910i
Samsung	SGH-Z500	QteK	9090
Samsung	SGH-Z500V	QteK	9100
Samsung	SGH-E770	QteK imate	8100
Samsung	SCH-V720	imate	K2
Samsung	SPH-E3700	QteK imate	8020
Samsung	SCH-A900	QteK imate	JASJAR
Samsung	SPH-V6900	HP	6515
Samsung	SPH-V7450	Siemens	S55
Samsung	SPH-V7400	Siemens	SL75
Samsung	SPH-X7700	Siemens	M75
Samsung	SPH-M600	Panasonic	X70
Samsung	SGH-E730	O2	XDA2 Mini
Samsung	SGH-E720	O2	XDA2 I
LG	KF-1000	Palmone	Treo 650
LG	LP-3900	Blackberry	7290
LG	P7200	Toshiba	A5504T
LG	S5200	SAZEM	myX6-2
LG	U8290		

Specifications

MP3/WMA Disc compatibility with this unit is limited as follows:

1. Sampling Frequency / 8 - 48kHz (MP3) 22.05 - 48kHz (WMA)
2. Bit rate / within 8 - 320kbps (include VBR) (MP3) 32 -320kbps (WMA)
3. CD-R/CD-RW file system should be "ISO 9660"
4. If you record MP3/WMA files using software which cannot create a FILE SYSTEM, for example "Direct-CD" etc., it will be impossible to playback MP3/WMA files. We recommend that you use "Easy-CD Creator" which creates an ISO9660 file system.

Customers should also note that permission is required in order to download MP3/WMA files and music from the Internet.

Our company has no right to grant such permission.

Permission should always be granted from the copyright owner.

GENERAL

Output Power	.60W x 4CH (Max.)
Power Source	DC 12 V
Speaker impedance	.4 Ω
Ground System	Negative
Dimensions (W x H x D)	.180 x 51 x 171 mm (Without Front Panel)
Net Weight	.2.0 kg

CD SELECTION

Frequency Response	.20 Hz-20 kHz
S/N Ratio	.93 dB
Distortion	.0.05 %
Channel Separation (1kHz)	.60 dB

RADIO SELECTION

FM

Frequency Range	.87.5-107.9 or 87.5-108 MHz
S/N Ratio	.60 dB
Distortion	.0.3 %
Usable Sensitivity	.2 dB μ V

AM (MW)

Frequency Range	.520-1720 or 522-1620 kHz
S/N Ratio	.55 dB
Distortion	.0.6 %
Usable Sensitivity	.24 dB μ V

LINE-OUT SELECTION

Frequency Response	.20 Hz-20 kHz
S/N Ratio	.100 dB
Distortion	.0.02 %
Channel Separation (1kHz)	.80 dB
Max Output Level (1kHz)	.5 V (1.2 K Ω)

Specifications



AUX SELECTION

Frequency Response	.20 Hz-20 kHz
S/N Ratio	.90 dB
Distortion	.002 %
Channel Separation (1kHz)	.80 dB
Max Input Level (1kHz)	.1.4 V (35 K Ω)

BLUETOOTH SELECTION

TX POWER	.4 dBm
Frequency Range	.2400-2483.5 MHz
Version	.Bluetooth 2.0 certified

USB SELECTION

Version	.USB 1.1
---------	----------



P/NO : MFL34184915