



MINI Hi-Fi SYSTEM OWNER'S MANUAL

MODEL: MCD202

MCD202-A0U/D0U/X0U

MCS202F

MCD102

MCD102-A0U/D0U/X0U

MCD102-A0/D0/X0

MCS102F

Before connecting, operating or adjusting this product,
please read this instruction booklet carefully and
completely.



Safety Precaution



CAUTION: TO REDUCE THE RISK OF ELECTRIC SHOCK DO NOT REMOVE COVER (OR BACK) NO USER-SERVICEABLE PARTS INSIDE REFER SERVICING TO QUALIFIED SERVICE PERSONNEL.



This lightning flash with arrowhead symbol within an equilateral triangle is intended to alert the user to the presence of uninsulated dangerous voltage within the product's enclosure that may be of sufficient magnitude to constitute a risk of electric shock to persons.



The exclamation point within an equilateral triangle is intended to alert the user to the presence of important operating and maintenance (servicing) instructions in the literature accompanying the product.

WARNING: TO PREVENT FIRE OR ELECTRIC SHOCK HAZARD, DO NOT EXPOSE THIS PRODUCT TO RAIN OR MOISTURE.

WARNING: Do not install this equipment in a confined space such as a book case or similar unit.

CAUTION: Do not block any ventilation openings. Install in accordance with the manufacturer's instructions.

Slots and openings in the cabinet are provided for ventilation and to ensure reliable operation of the product and to protect it from over heating.

The openings should be never be blocked by placing the product on a bed, sofa, rug or other similar surface. This product should not be placed in a built-in installation such as a bookcase or rack unless proper ventilation is provided or the manufacturer's instruction has been adhered to.



CAUTION:

This product employs a Laser System.

To ensure proper use of this product, please read this owner's manual carefully and retain it for future reference. Should the unit require maintenance, contact an authorized service center.

Use of controls, adjustments or the performance of procedures other than those specified herein may result in hazardous radiation exposure.

To prevent direct exposure to laser beam, do not try to open the enclosure. Visible laser radiation when open. **DO NOT STARE INTO BEAM.**

CAUTION: The apparatus should not be exposed to water (dripping or splashing) and no objects filled with liquids, such as vases, should be placed on the apparatus.

CAUTION concerning the Power Cord

Most appliances recommend they be placed upon a dedicated circuit;

That is, a single outlet circuit which powers only that appliance and has no additional outlets or branch circuits. Check the specification page of this owner's manual to be certain.

Do not overload wall outlets. Overloaded wall outlets, loose or damaged wall outlets, extension cords, frayed power cords, or damaged or cracked wire insulation are dangerous. Any of these conditions could result in electric shock or fire. Periodically examine the cord of your appliance, and if its appearance indicates damage or deterioration, unplug it, discontinue use of the appliance, and have the cord replaced with an exact replacement part by an authorized servicer.

Protect the power cord from physical or mechanical abuse, such as being twisted, kinked, pinched, closed in a door, or walked upon. Pay particular attention to plugs, wall outlets, and the point where the cord exits the appliance.

To disconnect power from the mains, pull out the mains cord plug. When installing the product, ensure that the plug is easily accessible.

USB

This Logo is only applicable to MCD202-A0U/D0U/X0U, MCD102-A0U/D0U/X0U models.

POWER SAVE MODE

You can set up the unit into an economic power save mode.

In the power-on status, press and hold  (POWER) button for about 3 seconds.

- Nothing is displayed in the display window when the unit goes into the power save mode.

To cancel power save mode, press  (POWER).

Before use

Contents

Before use

- About the Symbols for instruction / Notes on Discs / Notes on Tapes3
- Front / Back Panel4
- Remote Control5

Connections

- Speaker System Connections / Antenna (Aerial) Connections / Auxiliary Function6

Operation

- USB Function - OPTIONAL / About MP3/WMA7
- Audio Adjustment / Setting the Clock8
- Timer Function / Sleep Timer Function9
- Presetting the Radio Stations / Listening to the Radio10
- RDS Function - OPTIONAL11
- Tape Playback / Tape Recording12
- CD Playback13
- To Program Play / Repeat / To check MP3/WMA file information14

Reference

- Troubleshooting15
- Specifications16

About the symbols for instruction

 Indicates hazards likely to cause harm to the unit itself or other material damage.

Note Indicates special notes and operating features.

Notes on Discs

Handling discs

Do not touch the playback side of the disc. Hold the disc by the edges so that fingerprints do not get on the surface. Never stick paper or tape on the disc.

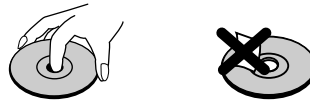

Storing discs

After playing, store the disc in its case. Do not expose the disc to direct sunlight or sources of heat and never leave it in a parked car exposed to direct sunlight.

Cleaning discs

Fingerprints and dust on the disc can cause poor picture quality and sound distortion. Before playing, clean the disc with a clean cloth. Wipe the disc from the center outward.

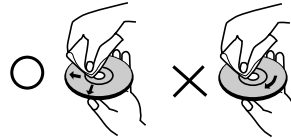

Do not use strong solvents such as alcohol, benzene, thinner, commercially available cleaners, or anti-static spray intended for older vinyl records.

Notes on Tapes

Preventing record

Removing the tab(s) of the cassette (with a small screwdriver) will prevent accidental erasure.

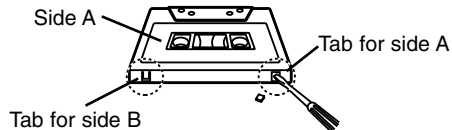

To record again, cover the hole of the tab with an adhesive tape.

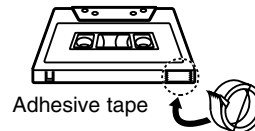

Front / Back Panel

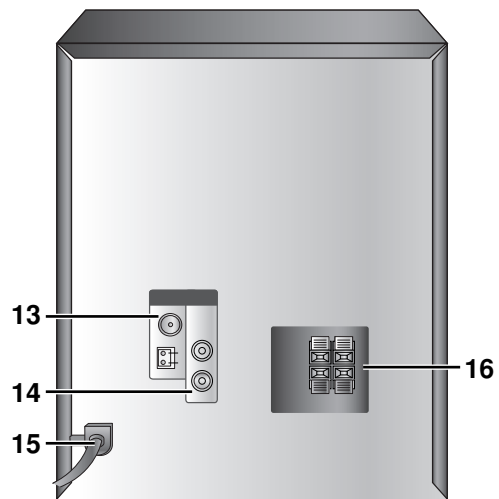
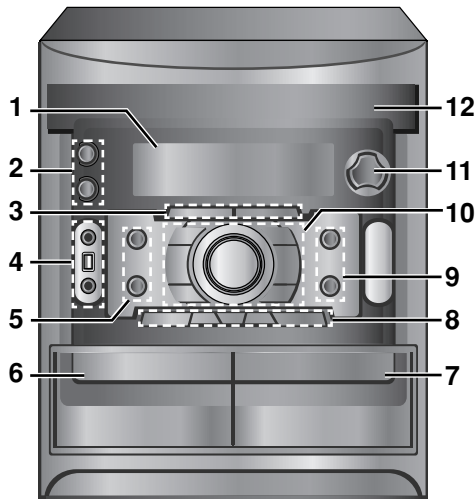

1. DISPLAY WINDOW
2. • (POWER) button
 - OPEN/CLOSE button
3. • XDS/MP3 OPT. button
 - XTS - PRO button
4. • USB (OPTIONAL)/DEMO button
 - USB connector (OPTIONAL)
 - PHONES (HEADPHONE JACK)
 - : \varnothing 3.5mm
5. • TUNER button
 - AUX button
6. PUSH EJECT position - TAPE 1
7. PUSH EJECT position - TAPE 2
8. • TUNING (-/+) buttons
 - (REWIND/FAST FORWARD) buttons
 - (CD SKIP/SEARCH) buttons
 - PRESET (-/+) buttons
 - FORWARD PLAY () button
 - STOP button

9. • CD button
 - TAPE button
10. • CLOCK button
 - TIMER button
 - RDS(OPTIONAL)/SET/CD button
 - EQ. button
 - CD SYNC./DUBB/ST./MONO button
 - REC button
 - VOLUME CONTROL KNOB
11. DISC SELECT (DISC1, DISC2, DISC3) buttons
12. DISC TRAY
13. AM/FM ANTENNA TERMINAL
14. AUX IN (AUXILIARY INPUT) connector
15. POWER CORD
16. SPEAKER TERMINAL

Remote Control

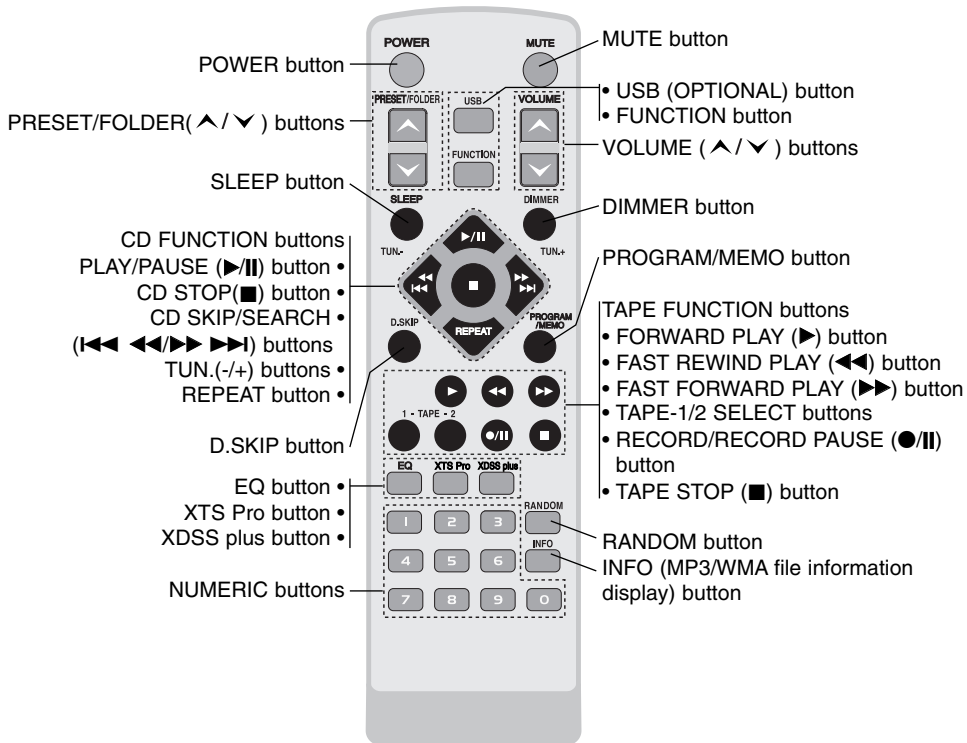

Remote Control battery installation

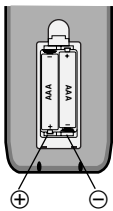

Detach the battery cover on the rear of the remote control, and insert two R03 (size AAA) batteries with ⊕ and ⊖ aligned correctly.

⚠ Caution

: Do not mix old and new batteries. Never mix different types of batteries (standard, alkaline, etc.).

Remote Control Operation Range

Point the remote control at the remote sensor and press the buttons.

- Distance : About 23 ft (7 m) from the front of the remote sensor.
- Angle : About 30° in each direction of the front of the remote sensor.

Connections

Speaker System Connections

Connect the speaker cables to the speaker terminal.

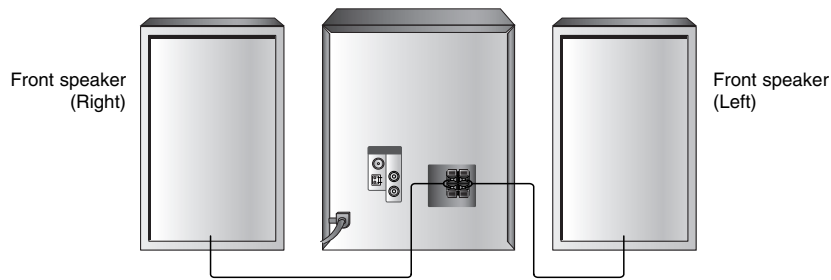

Notes:

- Be sure to match the speaker cord to the appropriate terminal on the components: + to + and – to –. If the cords are reversed, the sound will be distorted and will lack base.
- If you use front speakers with low maximum input rating, adjust the volume carefully to avoid excessive output on the speaker.
- Connect the Left/Right speaker correctly. If it reversed, the sound may be distorted.

Antenna (Aerial) Connections

Connect the supplied FM/AM antennas for radio reception.

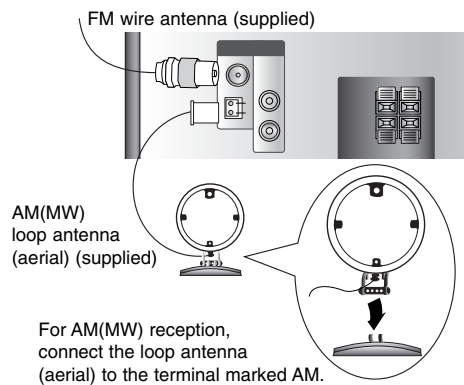

Notes:

- To prevent noise pickup, keep the AM loop antenna away from the unit and other components.
- Be sure to fully extend the FM wire antenna.
- After connecting the FM wire antenna, keep it as horizontal as possible.

Auxiliary Function

Connect an auxiliary device such as a TV or VCR via the rear mounted AUX connector and press **FUNCTION**.

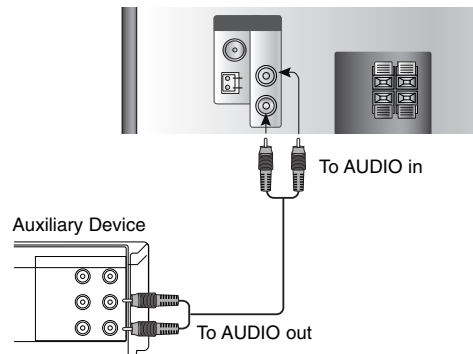

Note:

Turn the unit off and then connect an auxiliary device before you connect an auxiliary device. Because it may be made a noise.

Operation

USB Function - OPTIONAL

You can enjoy MP3/WMA media file saved on MP3 player or USB memory device by connecting the device to the USB port of this unit.

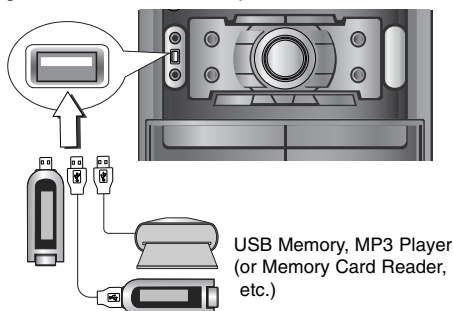

Compatible Devices

1. Devices which require additional program installation when you have connected it to a computer, are not supported.
2. MP3 Player : Flash type MP3 player.
 - The MP3 player requiring installation of a driver is not supported.
3. USB Flash Drive : Devices that support USB2.0 or USB1.1.

Basic Playback

1. Connect the USB device to the USB connector of your unit.
2. Press **USB** to select USB function. "CHECKING" appears in the display window, and then the total number of files is displayed.
3. Press **PLAY/PAUSE** (▶/■).
In addition, you can also play using the **NUMERIC** buttons.

To Remove the USB from the unit

1. Choose an other function except USB in order to remove the USB.
2. Remove the USB from the unit.

Note:

Besides Basic Playback, if you want to operate other functions, see the CD Playback section.

Moving to other cards

When you use a memory card, press **D.SKIP** on the remote control during playing or stopping.

Notes:

- Do not extract the USB device in operating.
- A back up demands to prevent a data damage.
- If you use a USB extension cable or USB hub, the USB device might not be recognized.
- A device using NTFS file system is not supported (Only the FAT (16/32) file system is supported.).
- The USB function of this unit does not support all USB devices.
- Digital camera and mobile phones are not supported.
- This unit is not supported when the total number of files is 1000 or more.

About MP3/WMA

MP3/WMA Disc compatibility with this unit is limited as follows:

1. Sampling Frequency
8 - 48kHz(MP3), 32 - 48kHz(WMA)
2. Bit rate
8 - 320kbps(MP3), 48 - 320kbps(WMA)
3. CD-R physical format should be "ISO 9660"
4. If you record MP3/WMA files using the software which cannot create a FILE SYSTEM, for example "Direct-CD" etc., it is impossible to playback MP3 files. We recommend that you use "Easy-CD Creator", which creates an ISO 9660 file system.
5. File names should be named using 30 letters or less and must incorporate ".mp3", ".wma" extension e.g. "*****.MP3" or "*****.WMA"
6. Do not use special letters such as "/ : * ? " < >" etc.
7. Even if the total number of files on the disc has more than 1000, it will only be shown up to 999.

About MULTI SESSION

- This function recognizes the multi session disc according to a disc of CD-ROM type.
- ex) If there are MP3/WMA files in the first session, the MP3/WMA file in the first session are only played.
If there are only MP3/WMA files in the whole session, all of the MP3/WMA files in the session are played.
If there is an Audio CD in the first session, only the Audio CD in the first session is played.

Presetting the Radio Stations

You can preset 50 stations for FM and AM.

1. Press **TUNER** on the front panel or **FUNCTION** on the remote control to select the frequency (AM or FM) you want.
2. Select a station you want by using **TUNING (-/+)** on the front panel. Or press the **TUN. (-/+)** on the remote control.

Tuning in automatically

- Press **TUNING (-/+)** on the front panel for more than 0.5 second.
Or press **TUN. (-/+)** on the remote control for more than 0.5 second. Scanning stops when the unit tunes in a station.

Tuning in manually

- Press **TUNING (-/+)** on the front panel [or press **TUN. (-/+)** on the remote control] briefly and repeatedly.
3. Press **PROGRAM/MEMO** on the remote control. A preset number will flash in the display window.
 4. Press **PRESET (-/+)** [or **PRESET/FOLDER (▲/▼)** on the remote control] to select the preset number you want.
 5. Press **PROGRAM/MEMO** again. The station is stored.
 6. Repeat the steps 1 (or 2) to 5 to store other stations.

To delete all the memorized stations

Press and hold **PROGRAM/MEMO** on the remote control for two seconds, "ERASE ALL" appears in the display window. And then **PROGRAM/MEMO** on the remote control again, the stations are deleted.

For your reference

If all stations have already been entered, "FULL" message will appear in the display window for a moment and then a preset number will flash. To change the preset number, follow the steps 4 - 5.

To recall presets

Press and hold **PRESET/FOLDER (▲/▼)** on the remote control until the desired preset number appears. Or press it repeatedly.

Listening to the Radio

1. Press **TUNER** on the front panel or **FUNCTION** on the remote control to select the frequency (AM or FM) you want. The last received station is tuned in.
2. Press **PRESET/FOLDER (▲/▼)** on the remote control repeatedly to select the preset station you want.
 - Each time you press the button, the unit tunes in one preset station at a time.
3. Adjust the volume by rotating the **VOLUME control knob** [or pressing **VOLUME (▲/▼)** on the remote control] repeatedly.

To listen to non-preset radio stations

- For manual tuning, see "Tuning in manually" in the step 2 on the left.
- For automatic tuning, see "Tuning in automatically" in the step 2 on the left.

To turn off the radio

Press **⏻/I (POWER)** to turn the unit off or select another function mode [CD, AUX, TAPE, USB (in the USB supplied models)].

For your reference

- If an FM program is noisy;
Press **ST./MONO** so that "STEREO" disappears in the display window. There will be no stereo effect, but the reception will be improved. Press **ST./MONO** again to restore the stereo effect.
- To improve reception;
Reposition the supplied antennas.

RDS Function - OPTIONAL

About RDS

This unit is equipped with RDS (Radio Data System), which brings a wide range of information to FM radio. RDS, now in use in many countries, is a system for transmitting station call signs or network information, a description of station programme type text message about the station or specifics of musical selection and the correct time.

RDS Tuning

When a FM station is tuned in and it contains RDS data, the unit will automatically display the station's call sign and the RDS indicator will light in the Display Window as well as indicators for the programme type recognition (PTY), Radio Text (RT), Clock Time (CT) and RDS services programme (PS) if transmitted by the station.

RDS Display Options

The RDS system is capable of transmitting a wide variety of information in addition to the initial call sign that appears when a station is first tuned. In normal RDS operation the display will indicate the station name, broadcast network or call letters. Pressing RDS enables you to cycle through the various data types in the sequence: (FREQUENCY → PTY → RT → CT → PS)

- PTY (Programme type recognition)- The name of the programme type is shown in the Display Window.
- RT (Radio text recognition)- The name of the radio text is shown in the Display Window.
- CT (Time controlled by the channel)- Enables the unit to receive the actual time and show it in the Display Window.
- PS (Programme Service name)- The name of the channel is shown in the Display Window.

Note:

Some RDS stations may not choose to include some of these additional features. If the data required for the selected mode is not being transmitted, the Display Window will show a PTY NONE, RT NONE, CT NONE or PS NONE message.

Programme Search (PTY)

A major benefit of RDS is its ability to encode broadcasts with Programme Type (PTY) codes that indicate the type of material being broadcast. The following list shows the abbreviations used to indicate each PTY along with an explanation of the PTY.

NEWS	News
AFFAIRS	Current Affairs
INFO	Information
SPORT	Sports
EDUCATE	Educational
DRAMA	Drama
CULTURE	Culture
SCIENCE	Science
VARIED	Varied Speech Programme
POP M	Popular Music
ROCK M	Rock Music
EASY M	Easy Listening Music
LIGHT M	Light Music
CLASSICS	Classical Music
OTHER M	Other Music
WEATHER	Weather Information
FINANCE	Financial Programmes
CHILDREN	Children's Programmes
SOCIAL	Social Affairs Programmes
RELIGION	Religious Broadcasts
PHONE IN	Phone-In Programmes
TRAVEL	Travel and Touring
LEISURE	Leisure and Hobby
JAZZ	Jazz Music
COUNTRY	Country Music
NATION M	National Music
OLDIES	Oldies Music
FOLK M	Folk Music
DOCUMENT	Documentary Programmes
TEST	Station Alarm Test Message
ALARM !	Emergency Broadcast Information

You may search for a specific Programme Type (PTY) by following these steps.

1. Press **TUNER** (or **FUNCTION**) to select FM mode.
2. Press **RDS**, the display will show the last PTY in use.
3. Press **PRESET (-/+)** repeatedly to select a desired PTY.
4. When the PTY is selected, press and hold **TUNING (-/+)**. The unit will go into an automatic search mode.
5. When a station is tuned, the search will stop.

Tape Playback

Use only normal tapes.

Basic Playback

1. Press **TAPE** (or **FUNCTION**) to select TAPE function.
("NO TAPE" appears in the display window.)
2. Load a tape.
3. Press **PLAY**(▶).

To Stop Play

Press ■ **STOP** during playback.

To Play Rewind or Fast Forward

After pressing ◀◀/▶▶ on the front panel or on the remote control during playback or stop, press **PLAY**(▶) at the point you want.

AUTO STOP DECK (TAPE 1/2)

After auto stop deck plays only the front side, the unit stops automatically.

Dubbing

This function shows how to record from tape to tape.

1. Press **TAPE** (or **FUNCTION**) to select tape function.
 - Cassette TAPE 1- Insert a playback tape to dub.
 - Cassette TAPE 2- Insert a blank tape.
2. Press **DUBB** as shown below.
To stop dubbing, press ■ **STOP**.

Tape Recording

Wind the tape to the point recording starts.

Use only normal tapes.

Basic Setting

1. Select a function you want to record except tape function.
2. Open the cassette TAPE 2 and insert a blank cassette into the cassette compartment.

General Recording

1. Press **REC/■** on the front panel or ●/|| on the remote control.
 - "REC" flashes and holds the cassette in pause mode.
2. Press **REC/■** on the front panel or ●/|| on the remote control again, then press **PLAY** (▶) to start playing the source you want to record. The recording begins.

To pause recording

Press ●/|| during recording.

- "REC" flashes in the display window.

To stop recording

Press ■ **STOP**.

CD to Tape Synchronized Recording

The CD synchro recording function dubs a complete CD and programmed titles automatically into a cassette.

1. Press **CD** and load a disc you want to record.
2. Press **CD SYNC**. in stop mode.
"REC" flashes and "CD SYNC" indicator lights.
3. The synchronized recording is started automatically after about 7 seconds.

Notes:

- If you wish to record from the desired track, select the desired track with **CD SKIP/SEARCH** (◀◀ ◀◀/▶▶ ▶▶) before commencing CD synchro recording.
- You cannot change any mode during recording.

CD Playback

Basic Playback

1. Press **CD** (or **FUNCTION**) to select CD function. If no disc is loaded then "NO DISC" is displayed.
2. Press **▲ OPEN/CLOSE** and place the disc into the disc tray.
The disc on the left (DISC 1) is played first.

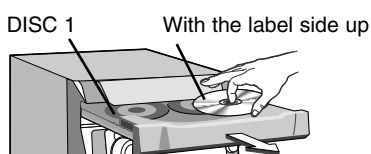

Note:

To load an 8cm (3 inch) disc, put it onto the inner circle of the tray.

3. Press **▲ OPEN/CLOSE** to close the disc compartment.
Audio CD : "READING" appears in the display window, and then the total number of tracks and the playing time are displayed.
MP3/WMA CD : "READING" appears in the display window, and then the total number of files is displayed.
4. Press **PLAY (▶)** on the front panel or **PLAY/PAUSE (▶/||)** on the remote control. In addition, you can also play an Audio CD or MP3/WMA CD using the **NUMERIC** buttons.

Pause Playback

Press **CD||** on the front panel or **PLAY/PAUSE (▶/||)** on the remote control during playback. Press this button again to resume play.

Stop Playback

Press **■ STOP** on the front panel or **CD STOP (■)** on the remote control during playback.

Searching a Track

Press **◀◀ ◀/▶▶ ▶▶** on the front panel, and then press once more at the point you want. Or hold **◀◀◀◀/▶▶▶▶** on the remote control during playback, then release at the point you want.

Note:

This function is only available for Audio CD's.

Skipping a Track

- Press **▶▶ ▶▶▶▶** to go to the next track.
- When the **◀◀◀◀** on the remote control is pressed once midway through a track, the player returns to the start of that track. When it is pressed again, a track is skipped each time the button is pressed.

To go to the next discs

Press **DISC SELECT** or **D.SKIP** during playing or stopping.

To select a disc directly

Press **DISC SELECT** or **D.SKIP** during playing or stopping.

When you press **DISC 1-3** before playing a disc, the unit will automatically start playing the selected disc.

To exchange discs during playback

You can open the disc tray while playing a disc to check what discs are to be played next and exchange discs, without interrupting playback of the current disc.

1. Press **▲ OPEN/CLOSE**.
The disc tray is opened. Two disc compartments appear. Even if the unit is playing a disc, it doesn't stop playing.
2. Replace discs in the compartments with other ones.
The unit plays the disc in the left compartment after the current disc, and then the one in the right compartment.
3. Press **▲ OPEN/CLOSE**.
The CD door closes.

Notes:

- Do not place more than one disc on one disc tray at the same time.
- Do not push on the disc tray to close CD door, you may damage the unit.

RANDOM

Press **RANDOM** on the remote control during playback. The tracks/files on the CD/MP3/WMA/USB (in the USB supplied models) will all play in random order.

"RANDOM" appears in the display window.

To cancel it, press **RANDOM** again.

MP3/WMA file folder function

Press **PRESET/FOLDER (▲/▼)** on the remote control to select the folder you want.

Note:

It is applied in the case that has several folder in MP3/WMA file.

To Program Play

You can arrange the order of the tracks on the discs and create your own program. The program can contain up to 20 tracks.

1. Press **PROGRAM/MEMO** on the remote control on stop mode.

"PROG." appears in the display window.

a. Audio/MP3/WMA CD

Disc Number
Track Number -  - Program number

- 1) Press **D.SKIP** or **DISC SELECT** (DISC 1/2/3) to select the disc.



- 2) Press **◀◀** **▶▶** to select the track.

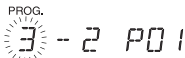

b. USB (in the USB supplied models)

file Number -  - Program number

- Press **◀◀** **▶▶** to select the file.

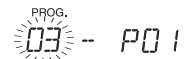

2. Press **PROGRAM/MEMO**.
3. Repeat the steps 1 - 2 above.
4. Press **PLAY/PAUSE** (**▶**) on the remote control or **PLAY** (**▶**) on the front panel.

To check program contents

Press **PROGRAM/MEMO** on stop mode.

- The disc, track and program number will be displayed in the display window.

To clear program contents

Press **PROGRAM/MEMO** on stop mode. And then press **CD STOP** (**■**).

To add program contents

1. Press **PROGRAM/MEMO** repeatedly in the program stop mode until the Track Number blinks.
2. Repeat the steps 2 - 4 above.

To modify program contents

1. Press **PROGRAM/MEMO** to display the program number you want to modify.
2. Repeat the steps 2 - 4 above.

Repeat

Press **REPEAT** during playback.

Audio CD

- REPEAT : To play one track repeatedly.
- ↓
- REPEAT DISC : To play one disc repeatedly.
- ↓
- REPEAT ALL DISC : To play all tracks on all discs repeat.
- ↓
- OFF(No display) : To cancel repeat play.

MP3/WMA

- REPEAT : To play one file repeatedly.
- ↓
- REPEAT FOLDER : To play one folder repeatedly.
- ↓
- REPEAT DISC : To play one disc repeatedly.
- ↓
- REPEAT ALL DISC : To play all files on all discs repeat.
- ↓
- OFF(No display) : To cancel repeat play.

USB (in the USB supplied models)

- REPEAT : To play one file repeatedly.
- ↓
- REPEAT FOLDER : To play one folder repeatedly.
- ↓
- REPEAT ALL : To play all files repeatedly.
- ↓
- OFF(No display) : To cancel repeat play.

Program repeat play

- REPEAT : To play one track (file) repeatedly.
- ↓
- REPEAT ALL DISC(CD) or REPEAT ALL(USB) : To play all program repeatedly.
- ↓
- OFF(No display) : To cancel program repeat play.

To check MP3/WMA file information

Press **INFO** during MP3/WMA file playback.

- The information (Title, Artist or Album) of the MP3/WMA file will be shown in the display window.
- If there is no the information of the MP3/WMA file, "NO ID3 TAG" or "NO WMA TAG" indicator will be shown in the display window.

Note:

This unit can play a CD-R or CD-RW that contains audio titles or MP3/WMA files.

Reference

Troubleshooting

Symptom	Cause	Correction
No power	<ul style="list-style-type: none">• The power cord is disconnected.	<ul style="list-style-type: none">• Plug the power cord into the wall outlet securely.
No sound	<ul style="list-style-type: none">• The audio cables (or SYSTEM connector jack) are not connected securely.	<ul style="list-style-type: none">• Connect the audio cable (or SYSTEM connector jack) into the jacks securely.
	<ul style="list-style-type: none">• The power of the external source equipment is switched off.	<ul style="list-style-type: none">• Switch on the external source equipment.
	<ul style="list-style-type: none">• The speaker cable is set to a wrong position.	<ul style="list-style-type: none">• Set the speaker cable to the correct position, then turn on the unit again by pressing POWER.
The unit does not start playback	<ul style="list-style-type: none">• An unplayable disc is inserted.	<ul style="list-style-type: none">• Insert a playable disc.
	<ul style="list-style-type: none">• The disc is placed upside down.	<ul style="list-style-type: none">• Place the disc with the playback side down.
	<ul style="list-style-type: none">• The disc is not placed within the guide.	<ul style="list-style-type: none">• Place the disc on the disc tray correctly inside the guide.
	<ul style="list-style-type: none">• The disc is dirty.	<ul style="list-style-type: none">• Clean the disc.
The remote control does not work properly	<ul style="list-style-type: none">• The remote control is not pointed at the remote sensor of the unit.	<ul style="list-style-type: none">• Point the remote control at the remote sensor of the unit.
	<ul style="list-style-type: none">• The remote control is too far from the unit.	<ul style="list-style-type: none">• Operate the remote control within about 23 ft (7 m).
	<ul style="list-style-type: none">• There is an obstacle in the path of the remote control and the unit.	<ul style="list-style-type: none">• Remove the obstacle.
	<ul style="list-style-type: none">• The batteries in the remote control are exhausted.	<ul style="list-style-type: none">• Replace the batteries with new ones.

Specifications

General

Power supply	Refer to the back panel of the unit.
Power consumption	Refer to the back panel of the unit.
Net Weight	5.57kg (MCD202 Model) 5.36kg (MCD102 Model)
External dimensions (WxHxD)	273 x 371 x 326 mm

Tuner

FM Tuning Range	87.5 - 108.0MHz or 65 - 74MHz, 87.5 - 108.0MHz
Intermediate Frequency	10.7MHz
Signal to Noise Ratio	60/55dB
Frequency Response	50 - 10000Hz
AM Tuning Range	522 - 1620kHz or 520 - 1720kHz
Intermediate Frequency	450kHz
Signal to Noise Ratio	30dB
Frequency Response	140 - 1800Hz

Amplifier

Output Power	100W + 100W (MCD202 Model) 50W + 50W (MCD102 Model)
T.H.D	0.5%
Frequency Response	40 - 20000Hz
Signal-to-noise ratio	75dB

CD

Frequency response	40 - 20000Hz
Signal-to-noise ratio	75dB
Dynamic range	75dB

Cassette tape player

Tape Speed	3000 ± 3% (MTT-111. NORMAL-SPEED)
Wow Flutter	0.25% (MTT -111, JIS-WTD)
F.F/REW Time	120sec (C-60)
Frequency Response	250 - 8000Hz
Signal to Noise Ratio	43dB
Channel Separation	50dB (P/B)/45 dB (R/P)
Erase Ratio	55dB (MTT-5511)

Speakers

Speaker Name	MCS202F	MCS102F
Type	Bass Reflex 2Way 2 Speaker	Bass Reflex 2Way 2Speaker
Impedance	4Ω	4 Ω
Frequency Response	60 - 20000Hz	60 - 20000Hz
Sound Pressure Level	84dB/W (1m)	85dB/W (1m)
Rated Input Power	100W	50W
Max. Input Power	200W	100W
Net Dimensions (WxHxD)	220 x 342 x 270mm	200 x 337 x 228 mm
Net Weight (1EA)	3.46kg	2.92kg

Designs and specifications are subject to change without notice.

P/NO : MFL36641604