



website: <http://www.lg.ca>



MICROWAVE OVEN

OWNER'S MANUAL & COOKING GUIDE

PLEASE READ THIS OWNER'S MANUAL
THOROUGHLY BEFORE OPERATING.

LMS1273SS/LMS2073SS

P/NO. MFL38260001
Printed in China

TABLE OF CONTENTS

safety	3- 4
precaution to Avoid Possible Exposure To Excessive Microwave Energy	3
Grounding Instructions	3
important Safety Instructions	4
Understanding Your Microwave Oven	5
Specifications	5
Installation	5
Part and accessories	6
Control panel	7
Cookware guide	8
Tip for microwave cooking	9
Precautions	10
Cleaning	10
Steam Chef	11-13
Setting Clock	14
Child Lock-Out	14
Utensils	15
Sensor Touch Operation Instruction	16
Sensor Touch Cook	16
Sensor Touch Popcorn	17
Microwaving Made Easy	18
Auto Cook	18
Melt	19
Soften	20
Auto Defrost	21
Express Defrost	21
Ez ON	22
Kitchen timer	22
More/Less	22
Custom Set	23
Time Cooking	23
Using Multi-Power Levels	24
Multi-Power Setting Guide	24
Multi-Stage Cooking	25
Cooking Tips	26-27
Heating or Reheating Guide	28
Fresh Vegetable Table	29
Troubleshooting	30
Questions and Answers	30-31
Before calling for service	32
Limited warranty	33

SAFETY

PRECAUTIONS TO AVOID POSSIBLE EXPOSURE TO EXCESSIVE MICROWAVE ENERGY

- **Do not attempt to operate this oven with the door open**, since open-door operation can result in harmful exposure to microwave energy. It is important not to defeat or tamper with the safety interlocks.
- **Do not place any object between the oven front face and the door**, or allow soil or cleaner residue to accumulate on sealing surfaces.
- **Do not operate the oven if it is damaged.** It is particularly important that the oven door closes properly and that there is no damage to the:
 - door (bent),
 - hinges and latches (broken or loosened),
 - door seals and sealing surfaces.
- **The oven should not be adjusted or repaired** by anyone except properly qualified service personnel.

GROUNDING INSTRUCTIONS

This appliance must be grounded. In the event of an electrical short circuit, grounding reduces the risk of electric shock by providing an escape wire for the electric current. This appliance is equipped with a cord having a grounding wire and a grounding plug. The plug must be plugged into an outlet that is properly installed and grounded.

PROPERLY POLARIZED AND
GROUNDED OUTLET

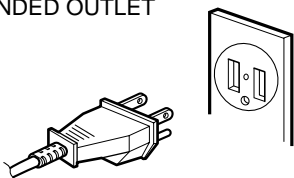

Three-Pronged
(Grounding) Plug.

⚠ WARNING ⚠

Improper grounding can result in a risk of electric shock. Consult a qualified electrician if the grounding instructions are not completely understood, or if doubt exists as to whether the appliance is properly grounded, and either:

1. If it is necessary to use an extension cord, use only a 3-wire extension cord that has a 3-blade grounding plug, and a 3-slot receptacle that will accept the plug on the appliance. The marked rating of the extension cord shall

be equal to or greater than the electrical rating of the appliance, or . . .

2. Do not use an extension cord. If the power supply cord is too short, have a qualified electrician or serviceman install an outlet near the appliance.

NOTES:

1. A short power-supply cord is provided to reduce the risks resulting from becoming entangled in or tripping over a longer cord.
2. Longer cord sets or extension cords are available and may be used if care is exercised in their use.
3. If a long cord or extension cord is used, (1) the marked electrical rating of the cord set or extension cord should be at least as great as the electrical rating of the appliance, (2) the extension cord must be a grounding-type 3-wire cord, and (3) the longer cord should be arranged so that it will not drape over the countertop or tabletop where it can be pulled on by children or tripped over accidentally.

SAFETY

IMPORTANT SAFETY INSTRUCTIONS

The safety instructions below will tell you how to use your oven to avoid harm to yourself or damage to your oven.

WARNING - To reduce the risk of burns, electric shock, fire, injury to persons, or exposure to excessive microwave energy:

1. Read all instructions before using the appliance.
2. Read and follow the specific **PRECAUTIONS TO AVOID POSSIBLE EXPOSURE TO EXCESSIVE MICROWAVE ENERGY** found on page 3 of this manual.
3. This appliance must be grounded. Connect only to properly grounded outlet.
See **GROUNDING INSTRUCTIONS** found on page 3 of this manual .
4. Install or locate this appliance only in accordance with the provided installation instructions.
5. Some products, such as whole eggs and sealed containers – for example, closed glass jars are able to explode and should not be heated in this oven.
6. Use this appliance only for its intended use as described in the manual. Do not use corrosive chemicals or vapors in this appliance. This type of oven is specifically designed to heat, cook, or dry food. It is not designed for industrial or laboratory use.
7. As with any appliance, close supervision is necessary when used by children.
8. Do not operate this appliance if it has a damaged cord or plug, if it is not working properly, or if it has been damaged or dropped.
9. This appliance should be serviced only by qualified service personnel. Contact the nearest authorized service facility for examination, repair, or adjustment.
10. Do not cover or block any openings on the appliance.
11. Do not store this appliance outdoors. Do not use this product near water – for example, near a kitchen sink, in a wet basement, near a swimming pool, or similar location.
12. Do not immerse cord or plug in water.
13. Keep cord away from heated surfaces.
14. Do not let cord hang over the edge of a table or counter.
15. When cleaning surfaces of door and oven that come together on closing the door, use only mild, nonabrasive soaps or detergents applied with a sponge or soft cloth.
16. To reduce the risk of fire in the oven cavity:
 - a. Do not overcook food. Carefully attend appliance when paper, plastic, or other combustible materials are placed inside the oven to facilitate cooking.
 - b. Remove wire twist-ties from paper or plastic bags before placing bag in oven.
 - c. If materials inside the oven ignite, **KEEP OVEN DOOR CLOSED**, turn oven off, and disconnect the power cord or shut off power at the fuse or circuit breaker panel.
 - d. Do not use the cavity for storage purposes. Do not leave paper products, cooking utensils, or food in the cavity when not in use.
17. Liquids such as water, coffee, or tea are able to be overheated beyond the boiling point without appearing to be boiling. Visible bubbling or boiling when the container is removed from the microwave oven is not always present. **THIS COULD RESULT IN VERY HOT LIQUIDS SUDDENLY BOILING OVER WHEN THE CONTAINER IS DISTURBED OR A SPOON OR OTHER UTENSIL IS INSERTED INTO THE LIQUID.** To reduce the risk of injury to persons; 1) Do not overheat the liquid. 2) Stir the liquid both before and halfway through heating it. 3) Do not use straight-sided containers with narrow necks. 4) After heating, allow the container to stand in the microwave oven for a short time before removing the container. 5) Use extreme care when inserting a spoon or other utensil into the container.
18. Avoid heating small-necked containers such as syrup bottles.
19. Avoid using corrosive and vapors, such as sulfide and chloride.
20. Liquids heated in certain shaped containers (especially cylindrical-shaped containers) may become overheated. The liquid may splash out with a loud noise during or after heating or when adding ingredients (instant coffee, etc.), resulting in harm to the oven and possible injury. In all containers, for best results, stir the liquid several times before heating. Always stir liquid several times between reheatings.

SAVE THESE INSTRUCTIONS

UNDERSTANDING YOUR MICROWAVE OVEN

SPECIFICATIONS

MODEL	LMS1273SS/LMS2073SS
Power Supply	120 V AC, 60 Hz
Rated Power Consumption	1500 W / 1480W
Microwave Output	*1100 W / *1100W
Frequency	2450 MHz
Rated Current	13.5 A / 13.0A
Overall Dimensions (WxHxD)	21 ⁷ / ₈ " x 12 ¹ / ₂ " x 17 ¹ / ₈ " / 23 ⁷ / ₈ " x 13 ⁹ / ₁₆ " x 19 ¹³ / ₁₆ "
Oven Cavity Dimensions (WxHxD)	14 ¹ / ₁₆ " x 9 ⁵ / ₈ " x 15 ⁵ / ₈ " / 16 ¹ / ₁₆ " x 11 ¹ / ₄ " x 18 ¹ / ₁₆ "
Capacity of Oven Cavity	1.2 Cu.ft. / 2.0 Cu.ft

*IEC 60705 RATING STANDARD

Specifications subject to change without prior notice.

INSTALLATION

A. Circuits

For safety purposes this oven must be plugged into a 15 or 20 Amp circuit. No other electrical appliances or lighting circuits should be on this line. If in doubt, consult a licensed electrician.

B. Voltage Warning

The voltage used at the wall receptacle must be the same as specified on the oven name plate located on the back or on the side of the control panel of the oven. Use of a higher voltage is dangerous and may result in a fire or other type of accident causing oven damage. Low voltage will cause slow cooking. In case your microwave oven does not perform normally in spite of proper voltage, remove and reinsert the plug.

C. Placement of the Oven

Your microwave oven can be placed easily in your kitchen, family room, or anywhere else in your home. Place the oven on a flat surface such as a kitchen countertop or a specially designed microwave oven cart. Do not place oven above a gas or electric range. Free air flow around the oven is important. Allow at least 4 inches of space at the top, sides, and back of the oven for proper ventilation.

D. Do not block the air vents

All air vents should be kept clear during cooking. If air vents are covered during oven operation the oven may overheat. In this case, a sensitive thermal safety device automatically turns the oven off. The oven will be inoperable until it has cooled sufficiently.

E. Radio interference

1. Microwave oven operation may interfere with TV or radio reception.
2. When there is interference, it may be reduced or eliminated by taking the following measures:
 - a. Clean the door and the sealing surfaces of the oven.
 - b. Reorient the receiving antenna of radio or television.
 - c. Relocate the microwave oven in relation to the TV or radio.
 - d. Move the microwave oven away from the receiver.
 - e. Plug the microwave oven into a different outlet so that microwave oven and receiver are on different branch circuits.

UNDERSTANDING YOUR MICROWAVE OVEN

PARTS AND ACCESSORIES

Your oven comes with the following accessories:

- 1 Use and Care Manual
- 1 Glass Turntable
- 1 Rotating Ring

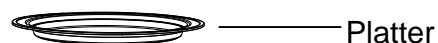
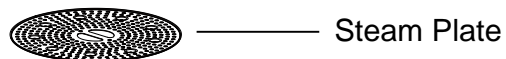
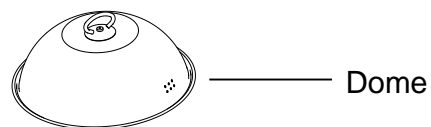
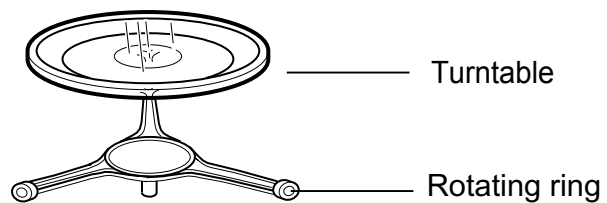
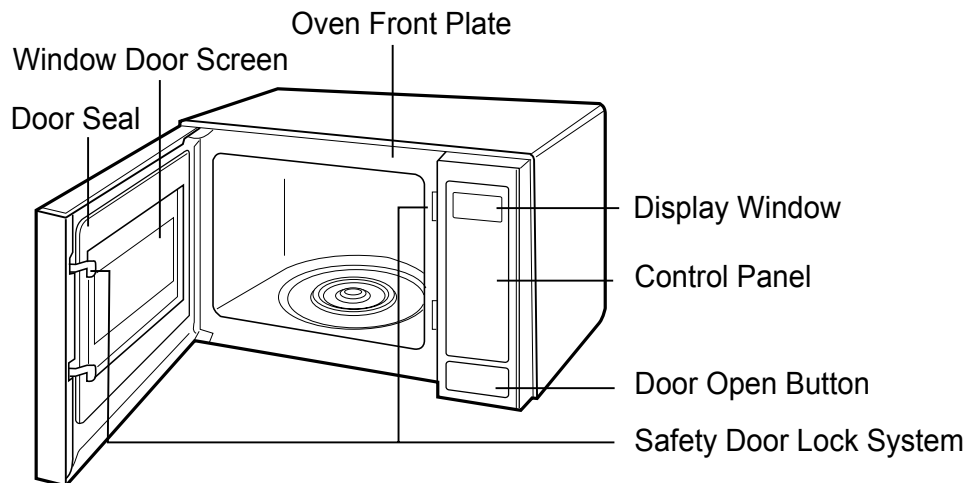

NOTE: This microwave oven is designed for household use only. It is not recommended for commercial use.

UNDERSTANDING YOUR MICROWAVE OVEN

CONTROL PANEL

- 1. DISPLAY.** The display includes a clock and indicators that tell you time of day, cooking time settings, and cooking functions selected.
- 2. SENSOR TOUCH** Touch this pad to cook without entering a cook power or time.
- 3. MELT.** Touch number pads to melt chocolate, cheese, butter, or marshmallows.
- 4. SOFTEN.** Touch this pad to soften ice cream, cream cheese, butter, or frozen juice.
- 5. EXPRESS DEFROST.** Touch this pad to thaw only 1lb of food very quickly.
- 6. AUTO COOK.** Touch this pad to select programming food items.
- 7. AUTO DEFROST.** Touch this pad to thaw ground meat, poultry, or steaks/chops by entering a weight.
- 8. NUMBER PADS.** Touch number pads to enter cooking time, power level, quantities, or weights.
- 9. TIME.** Touch this pad to set a cooking time.
- 10. POWER.** Touch this pad to set a cooking power.
- 11. MORE.** Each time you touch this pad, you add 10 seconds to the cooking time.
- 12. LESS.** Each time you touch this pad, you subtract 10 seconds from the cooking time.
- 13. CLOCK.** Touch this pad to enter the time of day.
- 14. KITCHEN TIMER.** Touch this pad to use your microwave oven as a kitchen timer.
- 15. CUSTOM SET.** Touch this pad to select sound(on/off), clock(on/off), scroll speed(slow, normal, fast) and unit(lbs./kg.).
- 16. EZ ON.** Touch this pad to cook at 100% cook power for 30 seconds up to 3 minutes; after 3 minutes, every touch will add 1 minute up to 99 min 59 seconds.
- 17. START.** Touch this pad to start all entries and to turn Child Lock on or off.
- 18. STOP/CLEAR.** Touch this pad to stop the oven or clear entries
- 19. STEAM.** The Steam Dome reflects the microwaves and boils the water in the platter creating steam. Food is cooked by steam alone; microwave DO NOT reach the food.
- 20. CRISP & SIZZLE.** The platter heats up and acts as a frying pan or baking sheet while the Steam Dome retains the heat and helps to evenly cook the food.



UNDERSTANDING YOUR MICROWAVE OVEN

COOKWARE GUIDE

Most heat-resistant, non-metallic cookware is safe for use in your microwave oven. However, to test cookware before using, follow these steps:

1. Place the empty cookware in the microwave oven.
2. Measure 1 cup of water in a glass measuring cup and place it in the oven beside the cookware.
3. Microwave on 100% power for 1 minute. If the dish is warm, it **should not** be used for microwave cooking.

USE	DO NOT USE
<p>Ovenproof Glass</p> <ul style="list-style-type: none"> • Glass treated for use in high-intensity heat includes utility dishes, bread dishes, pie plates, cake plates, liquid measuring cups, casseroles, and bowls without metallic trim. <p>China</p> <ul style="list-style-type: none"> • Bowls, cups, serving plates, and platters without metallic trim can be used in your oven. <p>Plastic</p> <ul style="list-style-type: none"> • When using plastic wrap as a cover, make sure that the dish is deep enough so the plastic wrap does not touch the food. As the food heats, it may melt the plastic wrap wherever the wrap touches the food. • Place plastic wrap loosely over the top of the dish and secure it by pressing the wrap to the sides of the dish. • Vent by turning back one corner of the plastic wrap. This will allow excess steam to escape. • Use plastic dishes, cups, semi-rigid freezer containers, and plastic bags only for short time cooking. Use these with care because the plastic may soften from the heat of the food. <p>Paper</p> <ul style="list-style-type: none"> • Microwave-safe paper towels, waxed paper, paper napkins, and paper plates with no metallic trim or design can be used in your oven. • Refer to the manufacturer's label for use of any paper product in the microwave oven. 	<p>Metal Utensil</p> <ul style="list-style-type: none"> • Metal shields food from microwave energy and produces uneven cooking. Avoid metal skewers, thermometers, or foil trays. • Metal utensils can cause arcing, which is a discharge of electric current. Arcing can damage your microwave oven. <p>Metal Decoration</p> <ul style="list-style-type: none"> • Do not use metal-trimmed or metal-banded dinnerware, casserole dishes, etc. <p>Centura™ Tableware</p> <ul style="list-style-type: none"> • The Corning Company recommends that you do not use Centura tableware and some Corelle™ closed-handle cups for microwave cooking. <p>Aluminum Foil</p> <ul style="list-style-type: none"> • Avoid large sheets of aluminum foil because they hinder cooking and may cause arcing. • Use small pieces of foil to shield poultry legs and wings. • Keep all aluminum foil at least 1 inch from the walls and door of the oven. <p>Wood</p> <ul style="list-style-type: none"> • Wooden bowls, boards, and baskets will dry out and may split or crack when you use them in the microwave oven. <p>Tightly Closed Containers</p> <ul style="list-style-type: none"> • Tightly closed cookware can explode. Be sure to leave an opening for steam to escape from covered cookware. <p>Brown Paper</p> <ul style="list-style-type: none"> • Avoid using brown paper bags. They absorb heat and could burn. <p>Metal Twist Ties</p> <ul style="list-style-type: none"> • Always remove metal twist ties as they can become hot and cause a fire.

UNDERSTANDING YOUR MICROWAVE OVEN

TIPS FOR MICROWAVE COOKING

BROWNING

Meat and poultry with high fat content that are cooked for 10 or 15 minutes or longer will brown lightly. Foods cooked a shorter time can be brushed with a browning agent, such as Worcestershire sauce, soy sauce, or barbecue sauce.

COVERING

A cover traps heat and steam and causes the food to cook more quickly. Use a lid or microwave-safe plastic wrap with one corner folded back to vent the excess steam. Lids on glass casseroles can become hot during cooking. Handle carefully. Waxed paper will prevent the food from splattering in the oven and help retain heat. When warming bread items, use waxed paper, napkins, or paper towels. To absorb extra moisture, wrap sandwiches and fatty foods in paper towels.

SPACING

Arrange individual foods, such as baked potatoes, cupcakes, and hors d'oeuvres in a circle and at least 1 inch apart. This will help the food cook more evenly.

STIRRING

Stirring blends flavors and redistributes the heat in foods. Always stir from the outside toward the center of the dish. Food at the outside of the dish heats first.

TURNING

Large foods, such as roasts and whole poultry, should be turned so that the top and bottom cook evenly. Also turn over chicken pieces and chops.

ARRANGEMENT

Do not stack food. Arrange in a single layer in the dish for more even cooking. Because dense foods cook more slowly, place thicker portions of meat, poultry, fish, and vegetables toward the outside of the dish.

TESTING FOR DONENESS

Because foods cook quickly in a microwave oven, you need to test frequently for doneness.

STANDING TIME

Food often needs to stand from 2 to 15 minutes after you remove it from the oven. Usually, you need to cover food during standing time to retain heat. Remove most foods when they are slightly undercooked and they will finish cooking during standing time. The internal temperature of food will rise about 10 °F during standing time.

SHIELDING

To prevent some portions of rectangular or square dishes from overcooking, you may need to shield them with small strips of aluminum foil to block the microwaves. You can also cover poultry legs and wing tips with foil to keep them from overcooking.

Always keep foil at least 1 inch from oven walls to prevent arcing.

PIERCING

Pierce the shell, skin, or membrane of foods before cooking to prevent them from bursting. Foods that require piercing include yolks and whites of eggs, hot dogs, clams, oysters, and whole vegetables, such as potatoes and squash.

UNDERSTANDING YOUR MICROWAVE OVEN

PRECAUTIONS

- Place the front surface of the door three inches or more from the countertop edge to avoid accidental tipping of the microwave oven during normal use.
- To program the oven, make sure you touch the center of each pad firmly since the areas between the pads will not activate the oven. A tone will sound each time a pad is touched correctly. Don't touch several pads at once.
- Do not strike the control panel with silverware, utensils, etc. Breakage may occur.
- Always use caution when taking the cooking utensils out of the oven. Some dishes absorb heat from the cooked food and may be hot. See Cookware Guide earlier in this section for more information.
- Do not rinse cooking utensils by placing them in water immediately after cooking. This may cause breakage. Also, always allow the turntable to cool before removing it from the oven.
- Never operate the oven when it is empty. Food or water should always be in the oven during operation to absorb the microwave energy.
- Do not use the oven to dry newspapers or clothes. They may catch fire.
- Use thermometers that have been approved for microwave oven cooking.
- The turntable must always be in place when you operate the oven.
- Do not use your microwave oven to cook eggs in the shell. Pressure can build up inside the shell, causing it to burst.
- There are several precautions to follow when microwaving popcorn:
 - Do not pop popcorn, except in a microwave-safe container or commercial packages designed for microwave ovens.
 - Never try to pop popcorn in a paper bag that is not microwave-approved.
 - Overcooking may result in smoke and fire.
 - Do not repop unpopped kernels.
 - Do not reuse popcorn bags.
 - Listen while corn pops. Stop oven when popping slows to 2-3 seconds between pops.
 - Do not leave microwave unattended while popping corn.
 - Follow directions on bag.

CLEANING

NOTE: Before cleaning the oven, unplug the power cord. If this is impossible, open the oven door to prevent an accidental oven start.

INTERIOR

Wipe the oven inside and outside with a soft cloth and a mild detergent solution. Then rinse and wipe dry. This should be done weekly or more often, if needed. Never use cleaning powders or rough pads. Excessive oil splatters on the inside top will be difficult to remove if left for many days. Wipe splatters with a wet paper towel, especially after cooking chicken or bacon.

REMOVABLE PARTS

The turntable and rotating ring are removable. They should be hand-washed in warm (not hot) water with a mild detergent and a soft cloth. Once they are clean, rinse well and dry with a soft cloth. Never use cleaning powders, steel wool, or rough pads.

- The turntable may be cleaned at the sink. Be careful not to chip or scratch the edges as this may cause the turntable to break during use.
- The rotating ring should be cleaned regularly.

DOOR

For best performance and safety, the inner door panel and the oven front frame should be free of food or grease buildup. Wipe often with a mild detergent; then rinse and wipe dry. Never use cleaning powders or rough pads.

After cleaning the control panel, touch STOP/CLEAR to clear any entries that might have been entered accidentally while cleaning the panel. Also make sure that the turntable and rotating ring are in the right position.

STEAM CHEF

Steam Chef cooking provides different features to make variety of cook. You can cook your favorite food with cooking guide, step by step. If you simply reheat food with Steam Chef, which will keep soft and smooth.

Food item in the Steam Chef cooking menu include:

1. Steam
2. Sizzle
3. Crisp

The Function uses the HI power only

The display will show different warning after every stage.

When cooking time is over, four short tones sound and End shows. Oven shuts off automatically.

EXAMPLE: To cooking pizza

1. Touch **STOP/CLEAR**.
2. Touch **CRISP**.
SELECT MANU 1 TO 4
--SEE COOKING GUIDE
scrolls in the display.
3. Touch **1**.
PIZZA
scrolls in the display.
4. Touch **START**.
Crisp starts. The display changes to crisp time count down.

STOP
CLEAR

CRISP

1

START
ENTER 

Note:

You need cook your food, step by step, according to the shows in the display or cooking table.

STEAM COOKING TABLE

Food	Quantity	Cook time at MW 100%	Display when food selected	Utensil
Fresh Vegetables-Soft	1 lb	10:00	Pour 1 cup of water in the Plate	Platter+Steam Plate+Dome
Fresh Vegetables-Hard	1 lb	13:00	Pour 1 cup of water in the Plate	Platter+Steam Plate+Dome
Fruits	1 lb	8:00	Pour 1 cup of water in the Plate	Platter+Steam Plate
Mussels	1 lb	8:00	Pour 1 cup of water in the Plate	Platter+Steam Plate+Dome
Fish filet	1 lb	10:00	Pour 1 cup of water in the Plate	Platter+Steam Plate+Dome
Boiled Eggs	1 to 12	8:00	Pour 1 cup of water in the Plate	Platter+Steam Plate+Dome
Rice	1 cup	18:00	Pour 1 cup of water in the Plate	Platter+Steam Plate+Dome

STEAM CHEF

SIZZLE COOKING TABLE

Food	Quantity	Preheat	Cook time at MW 100%		Beep and display	Utensil
			Stage1	Stage2		
Bacon	2-6 slices	3:00	3:00	3:00	After Preheat show "Place food" After Stage 1 show "Turn food over"	Platter+Dome
Chicken Breast	2-4 to 6 oz .each	3:00	5:00	4:00	After Preheat show "Place food" After Stage 1 show "Turn food over"	Platter+Dome
Steak	6-8 oz	3:00	3:00	3:00	After Preheat show "Place food" After Stage 1 show "Turn food over"	Platter+Dome
Fried Eggs	3-4 eggs large	3:00	3:00		After Preheat show "Place eggs with 2 tablespoons water"	Platter+Dome
Sausages	1 to 2 servings	None	3:00	3:00	After Stage 1 show "Turn food over"	Platter+Dome
BBQ Pork ribs	1 lb	None	3:00	5:00	*Cook without dome After Stage 1 show "Turn food over" *Stage 2 show "Cook with dome on"	Platter+Dome
Shrimp	1 lb	None	4:00	1:00	After Stage 1 show "Turn food over"	Platter+Dome

CRISP COOKING TABLE

Food	Quantity	Preheat	Cook time at MW 100%			Beep and display	Utensil
			Stage1	Stage2	Stage3		
Pizza	9 inch	None	6:00	4:00		After Stage 1 show "Remove dome"	Platter+Dome
French Fries	1 to 2 servings	3:00	6:00	6:00		After Preheat show "Place food" After Stage 1 show "Turn food over"	Platter+Dome
Chicken Nuggets	1 to 2 servings	None	4:00	3:00	1:00	After Stage 1 show "Turn food over" Stage 2 show "Remove dome"	Platter+Dome
Pretzel	1 to 4 pretzels	3:00	0:30	0:30		After Preheat show "Place food" After Stage 1 show "Turn food over"	Platter

STEAM CHEF

CAUTION

1. Do not use steam plate for frying. Insure you cover the platter with the dome.
2. Do not combine water and oil.
3. Before cooking you must insure that the dome is fully attached and covering the entire platter (see diagram). Failure to do so may cause sparking.
4. Place the platter in the center of the glass turntable. Do not let the dome or platter touch the side of the microwave.
5. Protect your hands use caution when removing. THE PLATTER IS HOT. Be sure to keep the platter level when removing to avoid and hot liquids leaking. This may result in scalding.
6. Before using insure the handle is fully installed. Turn clockwise to tighten. A loose handle can cause sparking.
7. Do not over fill the platter. Water should not exceed 1/3 of the depth of the platter. This is 300 g or 6-7 mm (see diagram)
8. Do not continue to use the platter or dome if cracked, flaking or rusted. A damaged platter may cause sparking.
9. Thoroughly cleaning after each use will prolong the life of the platter and prevent food items from burning on to the surface.
10. Keep out of the reach of children.
11. Do not place sealed containers in the steam chef
12. Do not use the steam plate without water. This can result in poor cooking results and possible fire.

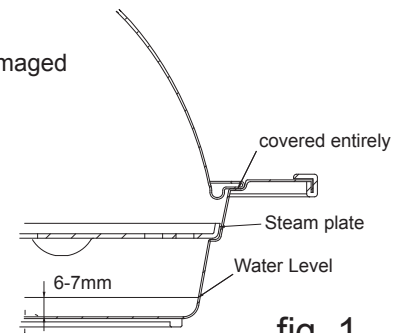

SETTING CLOCK

To set :

1. Touch **STOP/CLEAR**.
2. Touch **CLOCK. ENTER TIME OF DAY** scrolls in the display.
3. Enter the time by using the number key pads.
Example: To set **3:15**, touch number key pads [3],[1] and [5].
TOUCH START scrolls in the display.
4. Touch **START**.
AM TOUCH1 PM TOUCH2 scroll in the display.
5. Touch **number 2**.
6. Touch **START**.

STOP
CLEAR

CLOCK

3 1 5

START
ENTER 

2

START
ENTER 

CHILD LOCK - OUT

This is unique safety feature that prevents accidental running of the oven. Once the child lock - out is set, no cooking can take place.

When the child lock - out is set, you can't input any key.

To set :

1. Touch **STOP/CLEAR**.
2. Touch and hold **START/ENTER** until **LOCKED** appears in the display and two beeps are heard. If the time of day was already set, the time of day will return to the display window.

STOP
CLEAR

START
ENTER 

To cancel child lock - out :

1. Touch and hold **START/ENTER** until **LOCKED** disappears in the display. After the **CHILD LOCK** is turned off, the time of day will return to the display window. The oven will operate normally.

START
ENTER 

UTENSILS

ITEM	USE	COMMENTS
Disposable ovenable paperboard dishes	Cooking	Some frozen foods are packaged in these pans. Can be purchased in grocery stores.
Glassware Heat resistant oven glassware, glass-ceramic and ceramic, only	Cooking	Ideal for microwave cooking. May have many pieces available in your home. Do not use cracked or chipped dishes.
Oven cooking bags	Cooking	Follow manufacturers' directions. Close bag with either the nylon tie provided, a strip cut from the end of the bag, or a piece of cotton string. Do not close with metal twist tie. Make six 1/2-inch (1cm) slits by closure.
Parchment paper	Cooking	Use as a cover to prevent spattering.
Plastic Microwave-safe only, cooking and storage dishes	Cooking	Should be labeled, "Suitable for microwave heating." Check manufacturers' directions for recommended uses. Some microwave-safe plastic dishes are not suitable for cooking foods with high fat content.
Plastic wrap	Cooking	Use to cover foods during cooking to retain moisture.
Thermometers Microwave-safe, only	Cooking	Meat and candy thermometers are available.
Waxed paper	Cooking	Use as a cover to prevent spattering and to retain moisture.
Dinnerware Microwave-safe, only	Reheating and short term cooking	Check manufacturers' use and care directions for suitability for microwave heating. Some dinnerware may state on the back of the dish, "Microwave Oven Proof." Do not use cracked or chipped dishes.
Frozen dinner tray Aluminum	Reheating	Frozen dinners may be heated in foil tray, if tray is less than 3/4-inch (2cm) high. Place foil tray in center of oven. Leave at least 1-inch (2.5cm) space between foil tray and oven walls. Heat only 1 foil tray in the oven at a time. For containers more than 3/4-inch (2cm) deep, remove food and place in a similar size microwave-safe container.
Plastic	Reheating	Some frozen dinners have microwave-safe plastic trays.
Paper plates and cups	Reheating and short term cooking	Use to warm cooked foods and cook foods that require short cooking times such as wieners.
Paper towels and napkins	Reheating and cooking	Use to warm rolls and sandwiches. Use with supervision for a limited time only. Never use recycled paper.
Plastic Foam Cups	Reheating	Use to bring foods to a low serving temperature. Plastic foam will melt if foods reach a high temperature.
Aluminum foil	Shielding	Small strips of foil can be molded around thin parts of meat or poultry to prevent overcooking. Arcing can occur if foil is too close to oven wall.
Browning dish	Searing meats	Check browning dish information for instructions and heating chart. Do not preheat for more than 8 minutes.
Fast food carton with metal handle	None	May cause arcing.
Metal twist ties	None	They may cause arcing and could cause a fire in the oven.
Paper bags	None	May cause a fire in the oven.
Glass jars	Warming	Remove lid. Heat food until just warm. Most glass jars are not heat resistant and may break.

TO TEST A CONTAINER FOR SAFE MICROWAVE OVEN USE: Fill a 8 oz (250mL) glass measure with water and place it in the microwave oven along with the container to be tested; heat one minute at HIGH. If the container is microwave oven-safe, it should remain comfortably cool and the water should be hot. If the container is hot, it has absorbed some microwave energy and should not be used.

SENSOR TOUCH OPERATION INSTRUCTION

Quick Touch Sensor cooking provides exciting new features to make microwave oven easier. Your new microwave oven will guide you, step by step, whether it be simply to reheat food or cook food and sensor menu with all the popular food choices helps you to cook perfectly because it has been pre-programmed and can tell how long to cook or reheat food items.

Categories : SensorTouch Cook
Sensor Touch Popcorn

1. The Sensor Touch system works by detecting a build-up of vapor.
2. Make sure the door remains closed.
3. Opening the door or touching the STOP/CLEAR pad before the vapor is detected will abort the process. The oven will stop.
4. Before using Sensor Touch , make sure the glass turntable is dry, to assure the best results.

SENSOR TOUCH COOK

SENSOR TOUCH COOK allows you to cook most of your favorite food without having to select cooking times and power levels. This oven automatically determines required cooking times for each food item. This feature has 6 food categories.

Food item in the Sensor Touch Cook menu include:

1. Potato
2. Rice
3. Popcorn
4. Fresh Vegetable
5. Frozen Vegetable
6. Frozen Entree

EXAMPLE : To cook **FRESH VEGETABLE**, simply follow the steps below.

1. Touch **STOP/CLEAR**.

STOP
CLEAR

2. Touch **FRESH VEGETABLE**.

FRESH
VEGETABLE

The oven begins the cooking you selected without the need to touch START.

SENSOR TOUCH POPCORN

This feature makes preparation of microwave popcorn simple and quick... **one bag at a time.**

The automatic popcorn uses the HI power only.

The popping time counts down in the display.

When the popping time is over, two short and one long tones sound and End shows. Oven shuts off automatically.

Place one bag only(50-100g) of prepackaged microwave popcorn on a microwave-safe / oven-safe dish on the turntable. The package should be at room temperature.

1. Touch **STOP/CLEAR**.

STOP
CLEAR

2. Touch **POPCORN**.

POPCORN

The oven begins the cooking you selected without the need to touch START.

3. Open bag carefully. Popcorn and steam are extremely **hot**. Open bag by pulling top diagonal corners to avoid escaping steam.

NOTE :

- If popcorn bag size is not known, follow manufacturers' instructions and do not use this feature.
- Do not use POPCORN key pad in combination with any other feature key pads.
- Do not attempt to reheat or cook any unpopped kernels.
- Do not reuse bag. Overcooking can result in an oven fire.
- Prepare one bag only at a time.
- Do not use popcorn popping devices in microwave oven with this feature.
- Do not leave microwave unattended while cooking popcorn.

CAUTION : Never use a brown paper bag for popping corn.



When popping prepackaged popcorn; Place carefully so the bag does not touch the oven walls. Fold each end of the bag in half toward the center top of the bag.

MICROWAVING MADE EASY

Oven - guided cooking is a group of exciting new features to make microwaving easier. Your new microwave oven will guide you, step-by-step, whether it be simply to reheat food or to defrost and cook food. A blinking indicator informs you of every stage you are at in the process, and prompts you along, each step of the way. And an easy-to-use menu with all the popular food/beverage choice helps you to cook more perfectly because it has been pre-programmed and knows how long to cook, defrost or reheat various food items.

Called: **AUTO COOK**
MELT
SOFTEN
AUTO DEFROST
EXPRESS DEFROST

AUTO COOK

Auto Cook made easy! Your oven's menu has been preprogrammed to automatically cook food. Tell the oven what you want and how many items there are. Then let your microwave oven cook your selections.

EXAMPLE: To cook 4 slices, of bacon simply follow the steps below.

1. Touch **STOP/CLEAR**. STOP
CLEAR

2. Touch **AUTO COOK**.
SELECT MENU 1 TO 6
-- SEE COOKING GUIDE scroll in the display.
3. Touch number **1**.
BACON TOUCH 2 TO 6 SLICES scroll in the display.
4. Touch number **4**.

The oven begins the cooking you selected without the need to touch **START**.

AUTO COOK

1

4

AUTO COOK CHART

Code	Category	Direction	Amount
1	Bacon	Place bacon strips on microwave bacon rack for best results. (Use diner plate lined with paper towels if none available.)	2-6 slices
2	Frozen Roll/Muffin	Remove from display package and place on plate. (If muffins are over 3 oz. each, count as two when keying quantity.)	1-6 pieces. (2-3 ounces each)
3	Fresh Roll/Muffin	Remove from display package and place on plate. (If muffins are over 3 oz. each, count as two when keying quantity.)	1-6 pieces. (2-3 ounces each)
4	Beverage	Remove from display package and place on plate. (Be careful! The beverage will be very hot! Sometimes liquids heated in cylindrical containers will splash out when the cup is moved.)	1-2 cups
5	Chicken Pieces	Place th chicken pieces in an appropriately sized microwavable container, cover with plastic wrap, and vent.	1/2-2.0 lbs
6	Hot Cereal	Prepare as directed on package and cook. Stir and allow standing time before eating. Use only instant hot cereal.	1-6 servings

MELT

The oven uses low power to melt foods (butter, chocolate, marshmallows and cheese). See the following table.

EXAMPLE: To Melt 8 oz. Chocolate.

1. Touch **STOP/CLEAR**. STOP
CLEAR
2. Touch **MELT**. MELT
SELECT MENU 1 TO 4
-- SEE COOKING GUIDE
scroll in the display.
3. Touch number **2**. **2**
CHOCOLATE TOUCH 1 TO 2 scroll
in the display.
4. Touch number **2**. **2**

The oven begins the cooking you selected without the need to touch **START**.

MELT TABLE

Code	Category	Direction	Amount
1	Butter/Margarine	Unwrap and place in microwavable container. No need to cover butter. Stir at the end of cooking to complete melting.	1, 2 or 3 sticks
2	Chocolate	Chocolate chips or squares of baking chocolate may be used. Unwrap squares and place in microwavable container. Stir at the end of cycle to complete melting.	4 or 8 oz.
3	Cheese	Use processed cheese food only. Cut into cubes. Place in a single layer in microwavable container. Stir at the end of cooking to complete melting.	8 or 16 oz.
4	Marshmallows	Large or miniature marshmallows may be used. Place in microwavable container. Stir at the end of cycle to complete melting.	5 or 10 oz.

SOFTEN

The oven uses low power to soften food (butter, ice cream, cream cheese, and frozen juice). See the following table.

EXAMPLE: To Soften 8 oz. Ice Cream.

1. Touch **STOP/CLEAR**.

STOP
CLEAR

2. Touch **SOFTEN**.
SELECT MENU 1 TO 4
-- SEE COOKING GUIDE
scroll in the display.

SOFTEN

3. Touch 2 .
ICE CREAM TOUCH 1 TO 3
scroll in the display.

2

4. Touch 2 .

2

The oven begins the cooking you selected without the need to touch START.

SOFTEN TABLE

Code	Category	Direction	Amount
1	Butter	Unwrap and place in microwavable container. No need to cover butter. Butter will be at room temperature and ready for use in recipe.	1, 2 or 3 sticks
2	Ice Cream	Place container in oven. Ice cream will be soft enough to make scooping easier.	Pint, Quart, Half gallon
3	Cream Cheese	Unwrap and place in microwavable container. Cream cheese will be at room temperature and ready for use in recipe.	3 or 8 oz.
4	Frozen Juice	Remove top. Place in oven. Frozen juice will be soft enough to easily mix with water.	6, 12 or 16 oz.

AUTO DEFROST

The AUTO DEFROST feature is an accurate defrosting method for frozen ground meat poultry fish up to 6.0 lbs or 4.0 kg.

The oven automatically determines required defrosting times for each food item according to the weight you enter.

Simply tell the oven the type of your frozen food and enter the food weight. The oven calculates the rest.

For added convenience, the AUTO DEFROST Feature contains a built-in beep mechanism that lets you check, turn over, separate or rearrange as recommended in the express defrost chart in the last .

Three different defrosting levels are provided:

- 1 MEAT
- 2 POULTRY
- 3 FISH

EXAMPLE: To defrost 1.2 lbs of ground beef.

1. Touch **STOP/CLEAR**.
2. Touch **AUTO DEFROST**.
MEAT TOUCH 1
POULTRY TOUCH 2
FISH TOUCH 3 scrolls in the display.
3. Touch number **1**.
ENTER WEIGHT scrolls in the display.
4. Enter the weight by touching [**1**] and [**2**].
TOUCH START scrolls in the display.
5. Touch **START**.
Defrosting starts. The display changes to defrost time count down.

STOP
CLEAR

AUTO
DEFROST

1

1 2

START
ENTER 

NOTE:

When you touch the START pad, the display changes to defrost time count down. The oven will beep during the DEFROST cycle. At each beep, open the door and turn over, separate, or rearrange the food. Remove any portions that have thawed. Return frozen portions to the oven and touch START to resume the defrost cycle.

- For best results, remove fish, shellfish, meat, and poultry from its original closed paper or plastic package (wrapper). Otherwise, the wrap will hold steam and juice close to the foods, which can cause the outer surface of the foods to cook.
- For best results, shape your ground meat into the form of a doughnut before freezing. When defrosting, scrape off thawed meat when the beep sounds and continue defrosting.
- Place foods in a shallow container or on a microwave roasting rack to catch drippings.
- Food should still be somewhat icy in the center when removed from the oven.

EXPRESS DEFROST

The EXPRESS DEFROST feature provides you with the quick defrosting method for 1.0 pound frozen foods.

EXAMPLE: To defrost 1lb food.

1. Touch **STOP/CLEAR**.
2. Touch **EXPRESS DEFROST**.
3. Time counting down automatically.

STOP
CLEAR

EXPRESS
DEFROST

Ez ON

A time-saving pad, this simplified control lets you quickly set and start microwave cooking without the need to touch **START**.

NOTE: If you touch **Ez On**, it will add 30 seconds up to 3 minutes; after 3 minutes, every touch will add 1 minute up to 99 min 59 seconds.

EXAMPLE: To set **EZ ON** cooking for 1 minute.

1. Touch **STOP/CLEAR**.
2. Touch **EZ ON** 2 times.
3. The oven begins cooking 1 minute and display shows time counting down.

STOP
CLEAR

EZ ON

KITCHEN TIMER

You can use the Kitchen Timer of your oven for purposes other than food cooking.

Example :

To count 3 minutes for an egg or telephone call.

1. Touch **STOP/CLEAR**.
2. Touch **KITCHEN TIMER**.
ENTER TIME IN MIN AND SEC scrolls in the display.
3. Touch numbers for time.
Example : 3 minutes.
Touch number key pads. [3],[0] and[0].
TOUCH START scrolls in the display.
4. Touch **START**.

STOP
CLEAR

KITCHEN
TIMER

3 0 0

START
ENTER 

MORE / LESS

By using the MORE or LESS keys, AUTO COOK, and COOK TIME program can be adjusted to cook food for a longer or shorter time. Pressing MORE will add 10 seconds to the cooking time each time you press it. Pressing LESS will subtract 10 seconds of cooking time each time you press it.

NOTE:

Press the MORE or LESS pad during time countdown.

Example: If you want to adjust the RICE (1 cup) cooking time for a longer time period.

1. Touch **STOP/CLEAR**.
2. Touch **AUTO COOK**.
Display scrolls the words.
SELECT MENU 1 TO 6
--SEE COOKING GUIDE.
3. Touch **1**.
4. Touch **2**.
5. Touch **MORE**.

STOP
CLEAR

AUTO
COOK

1

2

MORE

CUSTOM SET

CUSTOM SET provides 4 modes which make using your microwave oven quite handy. You can select SOUND ON/OFF, CLOCK ON/OFF, SCROLL SPEED and LBS/KG.

EXAMPLE: To turn off Sound of beeper.

1. Touch **STOP/CLEAR**.
2. Touch **CUSTOM SET**.
4 modes show in the display repeatedly. You can set them according to your intention.
3. Touch number **1**.
SOUND ON TOUCH 1 OFF TOUCH 2 scrolls in the display.
4. Touch number **2**.
SOUND OFF shows in the display and the current time will be displayed.

STOP
CLEAR

CUSTOM
SET

1

2

NOTE: To turn beep sound back on, repeat steps 1 - 3 then touch number 1.

CUSTOM SET FUNCTION CHART

NO.	FUNCTION	CHOICE
1	SOUND ON/OFF	Sound On or Sound Off
2	CLOCK ON/OFF	Clock On or Clock Off
3	SCROLL SPEED	Slow, Normal, or Fast
4	LBS/KG CHOICE	Lbs or Kg

NOTE: When the power cord is first plugged in, the default setting are Sound ON, Clock On, Normal Speed and LBS.

TIME COOKING

This basic microwave cooking method allows you to cook food for a time period that you determine.

Set the time, and press START. Your oven begins cooking using its maximum power (HI POWER)

Foods with high moisture content should be cooked on maximum power, as this is the fastest cooking method and best maintains the natural flavour and texture of the foods.

EXAMPLE: To cook food on HI POWER for a 3 minutes 30 seconds.

1. Touch **STOP/CLEAR**.
2. Enter cooking time by touching the number pads. Touch **[3], [3] and [0]**
TOUCH START OR POWER scrolls in the display.
3. Touch **START**.

STOP
CLEAR

3 3 0

START
ENTER 

USING MULTI-POWER LEVELS

For foods requiring slower cooking, your oven also provides 10 different power settings.

The Multi-Power feature lets you choose a lower power level over the automatic HI (maximum oven power), so that food can be cooked more slowly.

Refer to the Multi-Power Setting Guide for the most suitable cooking level of various foods.

EXAMPLE: To cook food on 80% Power (Power 8) for a 5 minutes 30 seconds.

1. Touch **STOP/CLEAR**.
2. Enter 5 minutes 30 seconds by touching **TOUCH START OR POWER** scrolls in the display.
3. Touch **POWER**. **ENTER POWER LEVEL 1 TO 10** scrolls in the display.
4. Touch **8**. **POWER 80 TOUCH START** scrolls in the display.
5. Touch **START**.

STOP
 CLEAR

 5 3 0

 POWER

 8

START
 ENTER 

When cooking is complete, 4 short tones will sound. The word **COOK END** appears in the display window.

MULTI-POWER SETTING GUIDE

POWER LEVEL	OUTPUT (OF WATTS)	COOKING EXAMPLES
0	0	Standing time Indepartment timer
1	10%	Softening cream cheese. Keeping casseroles and main dishes warm.
2	20%	Softening chocolate. Heating breads, rolls, pancakes, tacos, tortillas and French toast. Clarifying butter. Taking the chill out of fruit. Heating small amounts of food.
3	30%	Thawing bread, small quantity of most food. Completing the cooking cycle of casseroles, stews and sauces. Cooking small quantities of most food.
4	40%	Cooking less tender cuts of meat in liquid or slow-cooking dishes. Completing the cooking cycle of less tender roasts.
5	50%	Cooking stews and soups after bringing to a boil. Cooking baked custards and pasta.
6	60%	Cooking scrambled eggs. Baking cakes.
7	70%	Cooking rump roast, ham, veal and lamb. Cooking cheese dishes. Cooking eggs and milk.
8	80%	Reheating precooked or prepared food quickly.
9	90%	Cooking onions, celery and green peppers quickly. Reheating meat slices quickly.
10(HIGH) Automatic	100%	Cooking poultry, fish, vegetables and most casseroles. Preheating the browning dish. Boiling water.

MULTI-STAGE COOKING

Multi-stage cooking lets you program up to 2 different cooking stages in advance—each stage with a different power level and time settings.

When **START** is pressed, the oven begins the first stage and automatically proceeds to the second and the third stage.

Two beep sound between stages.

When all programmed stages are over, four short tones sound and **COOK END** shows in the display window.

EXAMPLE: To cook and simmer spaghetti sauce, here is how to set all two stages at the beginning.

First Stage (10 minutes, power level: HI)

1. Touch **STOP/CLEAR**.
2. Touch **TIME**.
ENTER COOKING TIME scrolls in the display.
3. Enter 10 minutes by touching [1], [0], [0] and [0].
TOUCH START OR POWER scrolls in the display.

STOP
CLEAR

TIME

1 0 0 0

Second Stage (8 minutes, power level: 7 (70))

4. Touch **TIME**.
ENTER COOKING TIME scrolls in the display.
5. Enter 8 minutes by touching [8], [0], and [0].
TOUCH START OR POWER scrolls in the display.
6. Touch **POWER**.
ENTER POWER LEVEL 1 TO 10 scrolls in the display.
7. Touch 7.
POWER 70 TOUCH START scrolls in the display.
8. Touch **START**.

TIME

8 0 0

POWER

7

START
ENTER 

COOKING TIPS

WARNING: Do not use aluminum foil during cooking cycle.

COOKING TIPS

Meat

1. No special techniques are required. Meat should be prepared as with conventional cooking. Season if desired. Always thoroughly defrost meat before cooking.
2. Place the meat on a microwave roasting rack or microwave-proof plate and place on the turntable.
3. Cook according to the Meat Cooking Table (below). Use the longer time for large cuts of meats and the shorter time for small cuts of meats. For thicker chops, use the longer time.
4. Turn the meat once halfway through the cooking time.
5. **Let stand** for 5–10 minutes wrapped in foil after cooking. The standing time is very important as it completes the cooking process.
6. Make sure meat, especially pork, is thoroughly cooked before eating.

Poultry

1. No special techniques are required. Poultry should be prepared as with conventional cooking. Season if desired.
2. Poultry should be thoroughly defrosted. Remove giblets and any metal clamps.
3. Prick the skin and brush lightly with vegetable oil unless the poultry is self-basting.
4. All poultry should be placed on a microwave roasting rack or a microwave-proof plate and placed on the turntable.
5. Cook according to the instructions in the Poultry Cooking Table below. Turn over halfway through the cooking time. Because of its shape, poultry has a tendency to cook unevenly, especially in very bony parts. Turning during roasting helps to cook these areas evenly.
6. **Let stand** for 5–10 minutes wrapped in foil after cooking before carving. The standing time is very important, since it completes the cooking process.
7. Make sure poultry is thoroughly cooked before eating. Whole poultry is completely cooked when the juices run clear from the inside thigh when it is pierced with a sharp knife. Poultry pieces should be pierced with a sharp knife through the thickest part to ensure that the juices are clear and the flesh is firm.

Meat Cooking Table

Meat	Microwave Power	Cooking Time Per Pound
BEEF		
Standing/Rolled Rib		
– Medium	8	9½ to 11½ minutes
– Well-done	8	11½ to 14 minutes
Ground Beef (to brown for casserole)	HIGH (100%)	6½ to 9½ minutes
Hamburgers, Fresh or defrosted (4 oz. each)		
– 2 patties	HIGH (100%)	2½ to 4½ minutes
– 4 patties	HIGH (100%)	3½ to 5½ minutes
PORK		
Loin, Leg	8	12½ to 16½ minutes
Bacon		
– 4 slices	HIGH (100%)	2½ to 3½ minutes
– 6 slices	HIGH (100%)	3½ to 4½ minutes

NOTE: The times listed above are only a guide. Allow for difference in individual tastes and preferences. The times may also vary due to the shape, cut, and composition of the food.

Poultry Cooking Table

Poultry	Microwave Power	Cooking Time Per Pound
CHICKEN		
Whole	8	11 to 15 minutes
Breast (boned)	8	10 to 14 minutes
Portions	8	11 to 17 minutes
TURKEY		
Whole	8	11 to 15 minutes

NOTES:

- The times listed above are only a guide. Allow for difference in individual tastes and preferences. The times may also vary due to the shape, cut, and composition of the food.
- If whole poultry is stuffed, the weight of the stuffed bird should be used when calculating the cooking time.

COOKING TIPS

COOKING TIPS (continued)

Fish

1. Arrange fish in a large shallow non-metallic dish or casserole.
2. Cover with pierced microwave plastic wrap or casserole lid.
3. Place the dish on the turntable.
4. Cook according to the instructions in the Fresh Fish Cooking Table below. Flakes of butter can be added to the fish if desired.
5. Let stand as directed in the Cooking Table before serving.
6. After standing time, check to see that the fish is thoroughly cooked. The fish should be opaque and flake easily.

Fresh Fish Cooking Table

Fish	Microwave Power	Cooking Time Per Pound	Butter	Standing Time
Fish Fillets	HIGH	4½ to 8 minutes	Add 15 to 30 ml (1 to 2 tbsp lemon juice)	2 to 3 minutes
Whole Mackerel, Cleaned and Prepared	HIGH	4½ to 8 minutes	–	3 to 4 minutes
Whole Trout, Cleaned and Prepared	HIGH	5½ to 9 minutes	–	3 to 4 minutes
Salmon Steaks	HIGH	5½ to 8 minutes	Add 15 to 30 ml (1 to 2 tbsp lemon juice)	3 to 4 minutes

HEATING OR REHEATING GUIDE

To heat or reheat successfully in the microwave, it is important to follow several guidelines. Measure the amount of food in order to determine the time needed to reheat. Arrange the food in a circular pattern for best results. Room temperature food will heat faster than refrigerated food. Canned foods should be taken out of the can and placed in a microwavable container. The food will be heated more evenly if covered with a microwavable lid or plastic wrap and vented. Remove cover carefully to prevent steam burns. Use the following table as a guide for reheating cooked food.

Items	Cook time (at HIGH)	Special Instructions
Sliced meat 3 slices (1/4-inch thick)	1-2 minutes	Place sliced meat on microwavable plate. Cover with plastic wrap and vent. *Note: Gravy or sauce helps to keep meat juicy.
Chicken pieces 1 breast 1 leg and thigh	2-3 1/2 minutes 1 1/2-3 minutes	Place chicken pieces on microwavable plate. Cover with plastic wrap and vent.
Fish fillet (6-8 oz.)	2-4 minutes	Place fish on microwavable plate. Cover with plastic wrap and vent.
Lasagna 1 serving (10 1/2 oz.)	6-8 minutes	Place lasagna on microwavable plate. Cover with plastic wrap and vent.
Casserole 1 cup 4 cups	1-3 1/2 minutes 5-8 minutes	COOK covered in microwavable casserole. Stir once halfway through cooking.
Casserole – cream or cheese 1 cup 4 cups	1 1/2-3 minutes 3 1/2-5 1/2 minutes	COOK covered in microwavable casserole. Stir once halfway through cooking.
Sloppy Joe or Barbecued beef 1 sandwich (1/2 cup meat filling) without bun	1-2 1/2 minutes	Reheat filling and bun separately. Cook filling covered in microwavable casserole. Stir once. Heat bun as directed in table below.
Mashed potatoes 1 cup 4 cups	1-3 minutes 5-8 minutes	COOK covered in microwavable casserole. Stir once halfway through cooking.
Baked beans 1 cup	1 1/2-3 minutes	COOK covered in microwavable casserole. Stir once halfway through cooking.
Ravioli or pasta in sauce 1 cup 4 cups	2 1/2-4 minutes 7 1/2-11 minutes	COOK covered in microwavable casserole. Stir once halfway through cooking.
Rice 1 cup 4 cups	1 1/2-3 1/2 minutes 4-6 1/2 minutes	COOK covered in microwavable casserole. Stir once halfway through cooking.
Sandwich roll or bun 1 roll	15-30 seconds	Wrap in paper towel and place on glass microwavable rack
Vegetables 1 cup 4 cups	1 1/2-2 1/2 minutes 4-6 minutes	COOK covered in microwavable casserole. Stir once halfway through cooking.
Soup 1 serving (8 oz.)	1 1/2-2 1/2 minutes	COOK covered in microwavable casserole. Stir once halfway through cooking.

FRESH VEGETABLE TABLE

Vegetable	Amount	Cook time at HIGH	Instructions	Standing Time
Artichokes (8oz. each)	2 medium 4 medium	5~8 10~13	Trim. Add 2 tsp water and 2 tsp juice. Cover.	2-3 minutes
Asparagus, Fresh, Spears	1lb.	3~6	Add 1/2 cup water. Cover.	2-3 minutes
Beans, Green & Wax	1 lb.	6~10	Add 1/2 cup water in 1 1/2 qt. casserole. Stir halfway through cooking.	2-3 minutes
Beets, Fresh	1 lb.	10~14	Add 1/2 cup water in 1 1/2 qt. covered casserole. Rearrange halfway through cooking.	2-3 minutes
Broccoli, Fresh, Spears	1lb.	4~6	Place broccoli in baking dish. Add 1/2 cup water.	2-3 minutes
Cabbage, Fresh, Chopped	1lb.	4~6	Add 1/2 cup water in 1 1/2 qt. covered casserole. Stir halfway through cooking.	2-3 minutes
Carrots, Fresh, Sliced	2 cups	2~4	Add 1/4 cup water in 1 qt. covered casserole. Stir halfway through cooking.	2-3 minutes
Cauliflower, Fresh, Whole	1lb.	4~6	Trim. Add 1/4 cup water in 1 qt. covered casserole. Stir halfway through cooking.	2-3 minutes
Flowerettes, Fresh Celery, Fresh, Sliced	2 cups 4 cups	2 1/2~4 4~6	Slice. Add 1/2 cup water in 1 1/2 qt. covered casserole. Stir halfway through cooking.	2-3 minutes
Corn, Fresh	2 ears	4~8	Husk. Add 2 tbsp water in 1 1/2 qt. baking dish. Cover.	2-3 minutes
Mushrooms, Fresh, Sliced	1/2 lb.	2~3 1/2	Place mushrooms in 1 1/2 qt. covered casserole. Stir halfway through cooking.	2-3 minutes
Parsnips, Fresh, Sliced	1lb.	4~6	Add 1/2 cup water in 1 1/2 qt. covered casserole. Stir halfway through cooking.	2-3 minutes
Peas, Green, Fresh	4 cups	6~8	Add 1/2 cup water in 1 1/2 qt. covered casserole. Stir halfway through cooking.	2-3 minutes
Sweet Potatoes Whole Baking (6-8 oz. each)	2 medium 4 medium	5~8 7~12	Pierce potatoes several times with fork. Place on 2 paper towels. Turn over halfway through cooking.	2-3 minutes 2-3 minutes
White Potatoes, Whole Baking (6-8 oz. each)	2 potatoes 4 potatoes	6~9 10~14	Pierce potatoes several times with fork. Place on 2 paper towels. Turn over halfway through cooking.	2-3 minutes 2-3 minutes
Spinach, Fresh, Leaf	1lb.	3~6	Add 1/2 cup water in 2 qt. covered casserole.	2-3 minutes
Squash, Acorn or Butternut, Fresh	1 medium	5~7	Cut squash in half. Remove seeds. Place in 8 x 8-inch baking dish. Cover.	2-3 minutes
Zucchini, Fresh, Sliced	1lb.	4~6	Add 1/2 cup water in 1 1/2 qt. covered casserole. Stir halfway through cooking.	2-3 minutes
Zucchini, Fresh, Whole	1lb.	5~8	Pierce. Place on 2 paper towels. Turn zucchini over and rearrange halfway through cooking.	2-3 minutes

TROUBLESHOOTING

Questions and Answers

Operation

Question	Answer
Why is the oven light not on during cooking?	There may be several reasons why the oven light is not on. Have you: <ul style="list-style-type: none"> • Set a cooking time? • Touched START? • Checked the light bulb?
Why does steam come out of the air exhaust vent?	Steam is normally produced during cooking. The microwave oven has been designed to vent this steam.
Will the microwave oven be damaged if it operates empty?	Yes. Never operate the oven empty or without the glass turntable.
Does microwave energy pass through the viewing screen in the door?	No. The metal screen bounces the energy back to the oven cavity. The holes (or ports) allow only light to pass through. They do not let microwave energy pass through.
Why does a tone sound when a pad on the control panel is touched?	The tone tells you that the setting has been entered.
Can my microwave oven be damaged if food is cooked for too long?	Like any other cooking appliance, it is possible to overcook food to the point that the food creates smoke and even possibly fire, and damage to the inside of the oven. It is always best to be near the oven while you are cooking.
When the oven is plugged into wall outlet for the first time, it might not work properly. What is wrong?	The microcomputer controlling your oven may temporarily become scrambled and fail to function as programmed when you plug in for the first time or when power resumes after a power interruption. Unplug the oven from the 120 volt household outlet and then plug it back in to reset the microcomputer.
Why do I see light reflection around the outer case?	This light is from the oven light which is located between the oven cavity and the outer wall of the oven.
What are the various sounds I hear when the microwave oven is operating?	The clicking sound is caused by a mechanical switch turning the microwave oven's magnetron ON and OFF. The heavy hum and clunk is from the change in power the magnetron draws as it is turned ON and OFF by a mechanical switch. The change in blower speed is from the change in line voltage caused by the magnetron being turned ON and OFF.

Food

Question	Answer
What is wrong when baked foods have a hard, dry, brown spot?	A hard, dry, brown spot indicates overcooking. Shorten the cooking or reheating time.
Why do eggs sometimes pop?	When baking, frying, or poaching eggs, the yolk may pop due to steam build-up inside the yolk membrane. To prevent this, simply pierce the yolk with a wooden toothpick before cooking. CAUTION: Never microwave eggs in the shell.

TROUBLESHOOTING

Questions and Answers (continued)

Food

Question	Answer
Why are scrambled eggs sometimes a little dry after cooking?	Eggs will dry out when they are overcooked, even if the same recipe is used each time. The cooking time may need to be varied for one of these reasons: <ul style="list-style-type: none"> • Eggs vary in size. • Eggs are at room temperature one time and at refrigerator temperature another time. • Eggs continue cooking during standing time.
Is it possible to pop popcorn in a microwave oven?	Yes, if using one of the two methods described below: (1) microwave-popping devices designed specifically for microwave cooking (2) prepackaged commercial microwave popcorn that is made for specific times and power output needed Follow exact directions given by each manufacturer for its popcorn popping product and do not leave the oven unattended while the corn is being popped. If corn fails to pop after the suggested time, discontinue cooking. Overcooking could result in an oven fire. CAUTION: <ul style="list-style-type: none"> • Never use a brown paper bag for popping corn or attempt to pop leftover kernels. • Do not pop prepackaged commercial microwave popcorn directly on the glass turntable. To avoid excessive heating of the glass turntable, place the popcorn bag on a plate. • Listen while corn pops. Stop oven when popping slows to 2-3 seconds between pops. • Do not leave microwave unattended while popping corn. • Follow directions on bag.
Why do baked apples sometimes burst during cooking?	The peel has not been removed from the top half of each apple to allow for expansion of the interior of the apple during cooking. As in conventional cooking methods, the interior of the apple expands during the cooking process.
Why do baked potatoes sometimes burn during cooking?	If the cooking time is too long, fire could result. At the end of the recommended cooking time, potatoes should be slightly firm. CAUTION: Do not overcook.
Why is a standing time recommended after microwave cooking time is over?	Standing time allows foods to continue cooking evenly for a few minutes after the actual microwave oven cooking cycle. The amount of standing time depends upon the density of the foods.
Why is additional time required for cooking food stored in the refrigerator?	As in conventional cooking, the initial temperature of food affects total cooking time. You need more time to cook food taken out of a refrigerator than for food at room temperature.

TROUBLESHOOTING

Before Calling for Service

You can often correct operating problems yourself. If your microwave oven fails to work properly, locate the operating problem in the list below and try the solutions listed for each problem.

If the microwave oven still does not work properly, contact the nearest GoldStar Authorized Service Center. GoldStar Authorized Service Centers are fully equipped to handle your service requirements.

Problem	Possible Causes
Oven does not start	<ul style="list-style-type: none">• Is the power cord plugged in?• Is the door closed?• Is the cooking time set?
Arcing or Sparking	<ul style="list-style-type: none">• Are you using approved cookware?• Is the oven empty?
Incorrect time of day	<ul style="list-style-type: none">• Have you tried to reset the time of day?
Unevenly Cooked Foods	<ul style="list-style-type: none">• Are you using approved cookware?• Is the glass turntable in the oven?• Did you turn or stir the food while it was cooking?• Were the foods completely defrosted?• Was the time/cooking power level correct?
Overcooked Foods	<ul style="list-style-type: none">• Was the time/cooking power level correct?
Undercooked Foods	<ul style="list-style-type: none">• Are you using approved cookware?• Were the foods completely defrosted?• Was the time/cooking power level correct?• Are the ventilation ports clear?
Improper Defrosting	<ul style="list-style-type: none">• Are you using approved cookware?• Was the time/cooking power level correct?• Did you turn or stir the food during the defrosting cycle?

LIMITED WARRANTY

Should your product prove to be defective in materials or workmanship under normal use during the warranty period listed below, which warranty period runs from the original date of purchase, LG Electronics will, at its option, repair or replace the product at no charge to you.

The warranty is valid only to the original purchaser of the product, during the warranty period, as long as it is in Canada.

LG Microwave Oven Warranty Period

<u>Components</u>	<u>Parts</u>	<u>Labor</u>
Over-the-Range	1Year	1 Year (In-Home Service)
All Convection	1Year	1 Year (In-Home Service)
Microwaves in Built-in application	1Year	1 Year (In-Home Service)
All Other Microwave Ovens	1Year	1 Year (Carry-In Service)
Magnetron	5Years	

No other warranty is applicable to this product. THE DURATION OF ANY IMPLIED WARRANTIES, INCLUDING THE IMPLIED WARRANTY OF MERCHANTABILITY, IS LIMITED TO THE DURATION OF THE EXPRESS WARRANTY HEREIN. LG ELECTRONICS SHALL NOT BE LIABLE FOR THE LOSS OF USE OF THE PRODUCT, INCONVENIENCE, LOSS OR ANY OTHER DAMAGES, DIRECT OR CONSEQUENTIAL, ARISING OUT OF THE USE OF OR INABILITY TO USE, THIS PRODUCT OR FOR ANY BREACH OF ANY EXPRESS OR IMPLIED WARRANTY, INCLUDING THE IMPLIED WARRANTY OF MERCHANTABILITY OR FITNESS FOR A PARTICULAR PURPOSE, APPLICABLE TO THIS PRODUCT.

Some Provinces or Territories do not allow for the exclusion or limitation of incidental or consequential damages of limitations on how long an implied warranty lasts; so these limitations or exclusions may not apply to you. This warranty gives you, (the original purchaser) specific legal rights and you may also have other rights, which vary from province to province or territory to territory.

THE ABOVE WARRANTY DOES NOT APPLY TO:

1. Service trips to your home to deliver and pickup, install, instruct or replace house fuses, or connect house wiring or plumbing, or correction of unauthorized repairs.
2. Damage to the product caused by accident, pest, fire, floods or acts of God.
3. Repairs when your LG product is used in other than normal, singlefamily household use or contrary to the instructions outlined in the product's owners manual.
4. Damage resulting from accident, alteration, misuse, abuse, or improper installation or maintenance.
5. Products with altered or removed serial numbers

If the product is installed outside the normal service area, any cost of transportation involved in the repair of the product, or the replacement of a defective part, shall be borne by you (the owner).

CUSTOMER ASSISTANCE INFORMATION:

To obtain Warranty Coverage:	Retain your Bill of Sale to prove the date of purchase. A copy of your Sales Receipt must be submitted when warranty service is provided. This warranty is invalid if the factory applied serial number has been altered or removed from the product.
To obtain Product or Customer Service Assistance:	Call 1-888-LG-CANADA (542 2623) Press the appropriate menu option, and have your product model and serial numbers and your postal code ready.
To obtain the nearest Authorized Service Center:	Access our web-site at: www.LG.ca (Service Option) or Call 1-888-LG-CANADA (542 2623) Press the appropriate menu option, have your product model and serial numbers and your postal code ready.